

**MODEL T4  
REAR  
POWER CONTROL UNIT  
OPERATION & MAINTENANCE  
MANUAL  
AND  
PARTS CATALOG**

*Peoria, Ill.* • **R. G. LeTOURNEAU, Inc.** • *Stockton, Calif.*

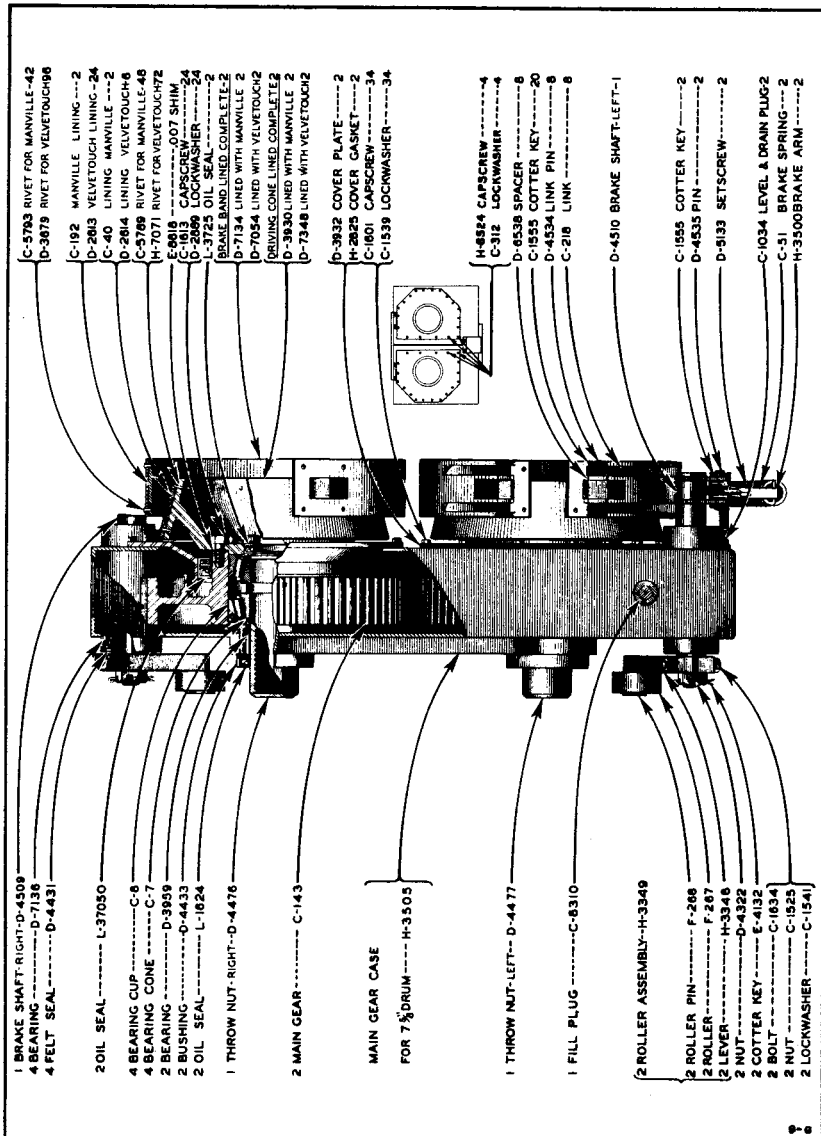

CASE GROUP H-3475

ALWAYS GIVE MACHINE NUMBER WHEN ORDERING PARTS

PRINTED IN U. S. A.

# MODEL T PCU

2

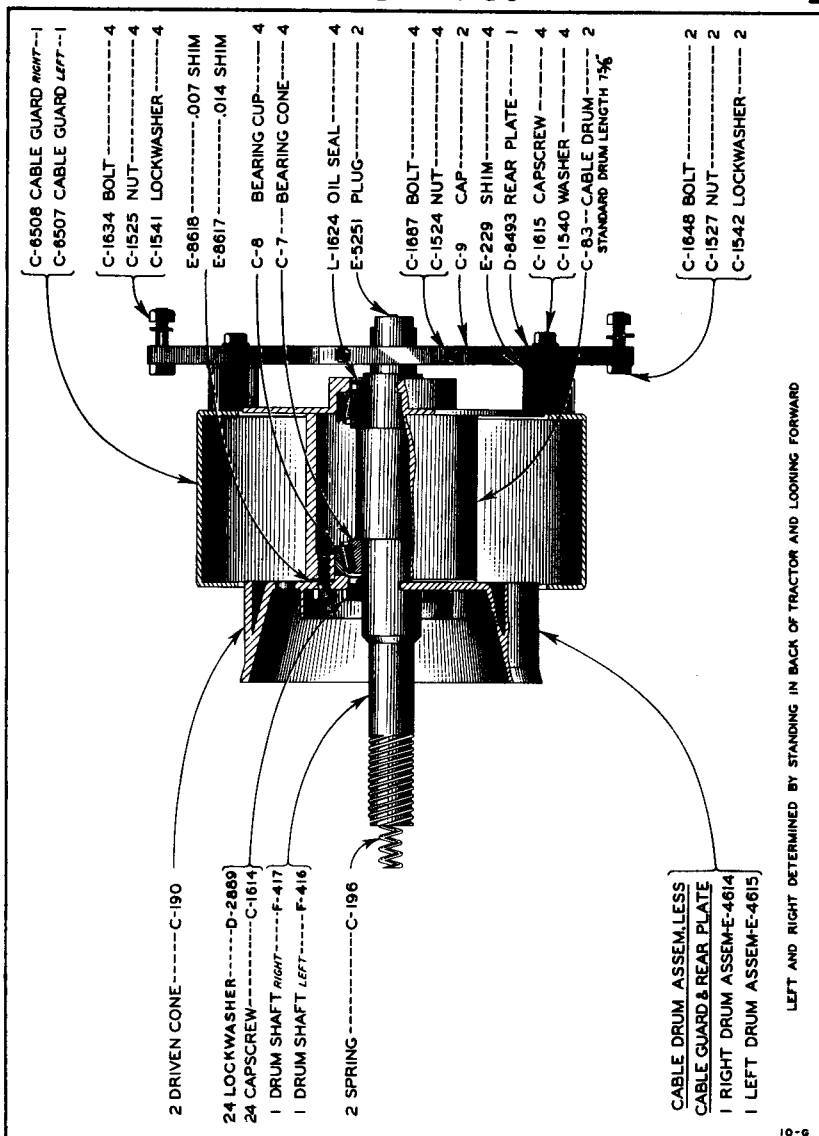

LEFT AND RIGHT DETERMINED BY STANDING IN BACK OF TRACTOR AND LOOKING FORWARD

## STANDARD CABLE DRUM GROUP D-9554

ALWAYS GIVE MACHINE NUMBER WHEN ORDERING PARTS

PRINTED IN U.S.A.

# MODEL T PCU

3

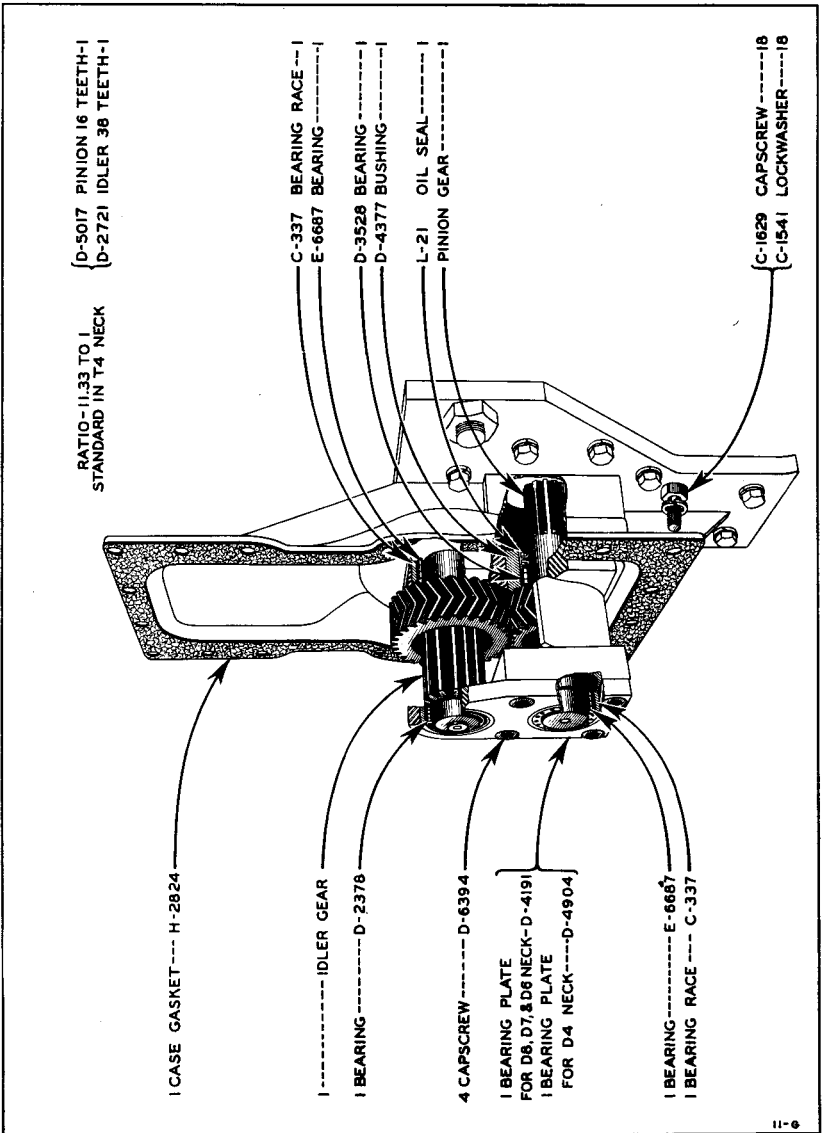

11-6

## NECK ASSEMBLY

ALWAYS GIVE MACHINE NUMBER WHEN ORDERING PARTS

PRINTED IN U. S. A.

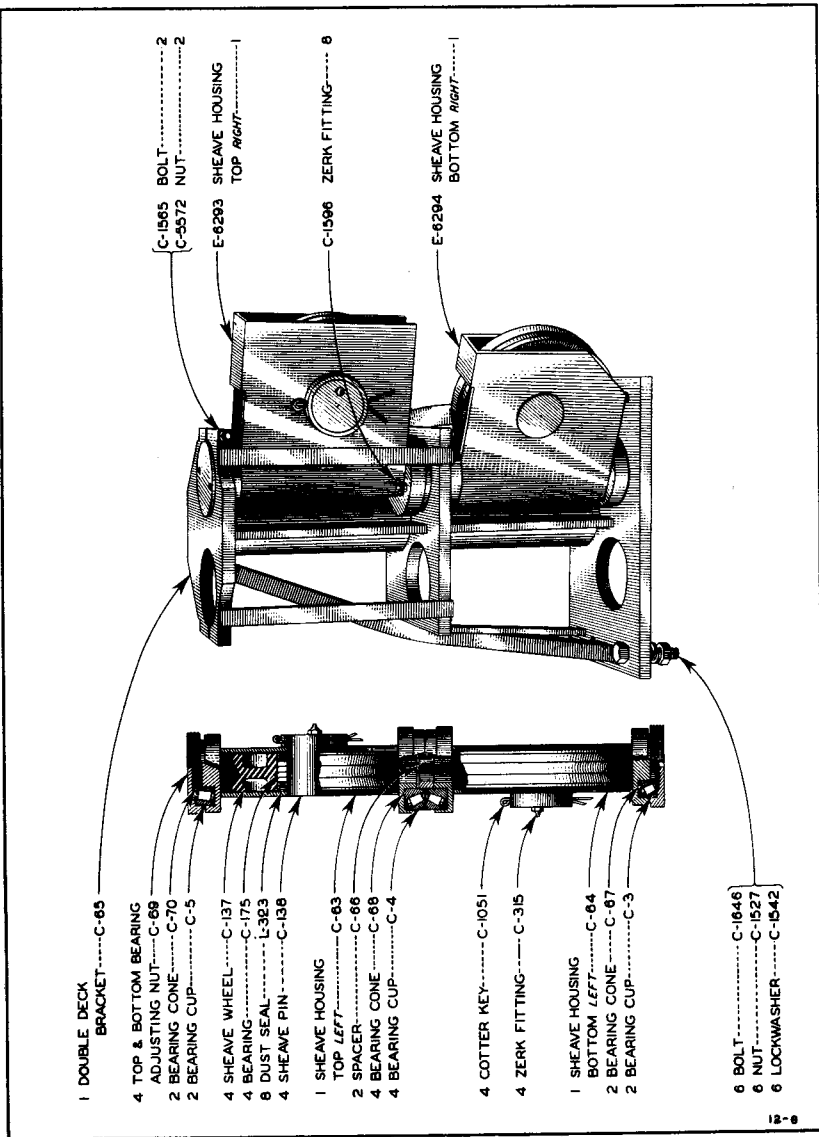

12-8

**DOUBLE DECKER GROUP E-4283**

ALWAYS GIVE MACHINE NUMBER WHEN ORDERING PARTS

PRINTED IN U. S. A.

# MODEL T PCU

5

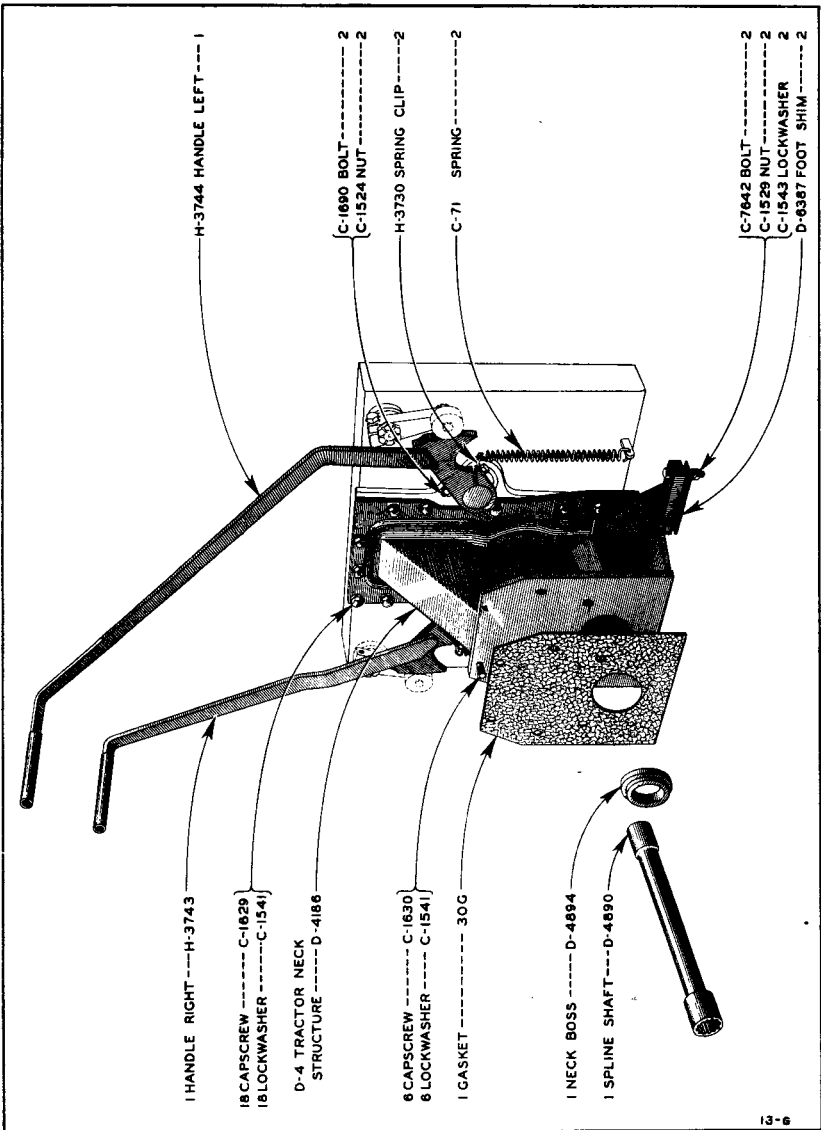

13-6

## D4 NECK GROUP H-4416

ALWAYS GIVE MACHINE NUMBER WHEN ORDERING PARTS

PRINTED IN U.S.A.

# MODEL T PCU

6

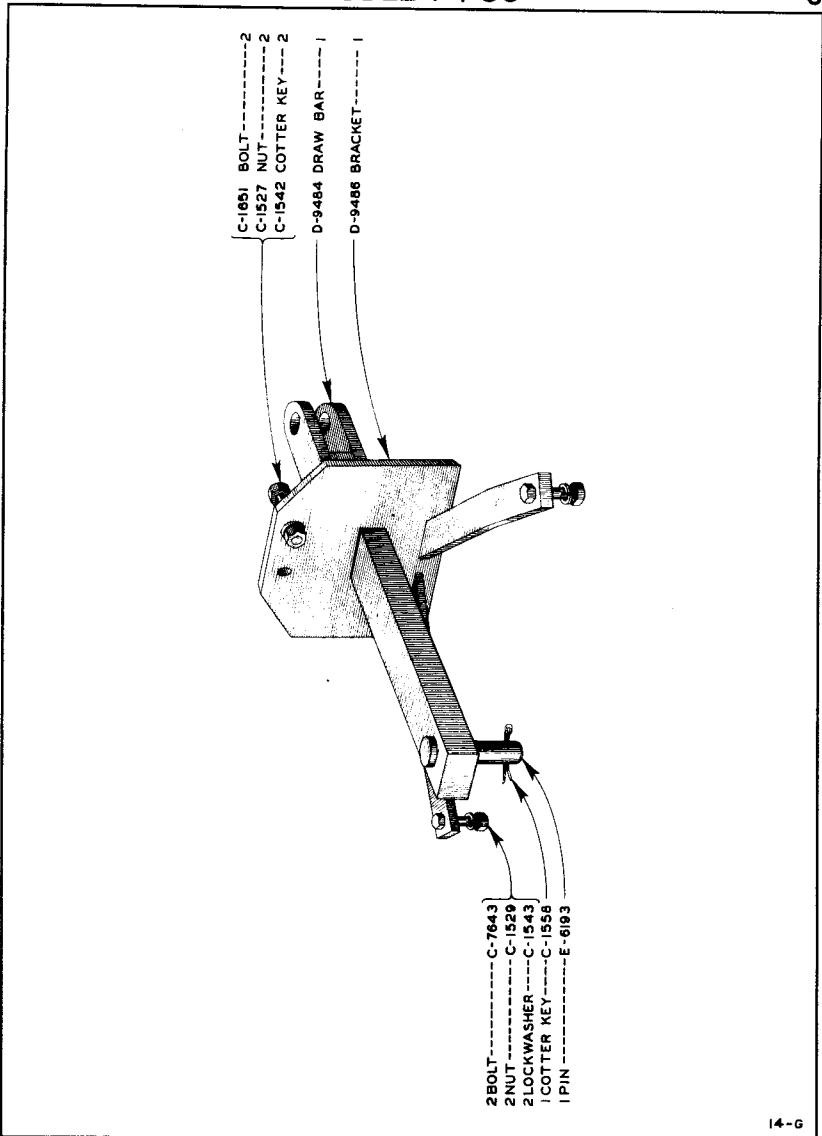

## D4 PCU DRAW BAR EXTENSION GROUP D-8695

ALWAYS GIVE MACHINE NUMBER WHEN ORDERING PARTS

PRINTED IN U. S. A.

**LETOURNEAU** *Parts*  
**PRICE LIST**

FOR  
UNITED STATES GOVERNMENT

CONTRACT **TPS-47788**  
JULY 1, 1942 TO JUNE 30, 1943

Field Officers who may wish to procure parts under this Schedule, but who have not been notified officially of its existence, are urged to communicate promptly with their Departments in Washington, D. C.

**PRICES**

All prices in this list are net F.O.B. Peoria, Ill., Stockton, Calif., or any LeTourneau Distributor.

Prices are net as per this list, and are subject to change by published amendment. Wholly new part numbers and prices may be released from time to time, and notice thereof will be provided by addenda sheets.

When a new part is released as an improvement of an old part, the new part will be charged whether higher or lower than the price published for the superseded part.

When parts and attachments are offered for resale outside of the continental U.S.A., the prices in this list are subject to the additions of all the costs of import peculiar to the country to which they may be shipped. Such costs ordinarily include import duties, sales and other taxes, brokerage fees, and any other expenses incidental to the importation of the goods. Prices, Specifications and Weights Subject to Change Without Notice.

**ORDERS**

To avail the Government of economies in transportation, orders irrespective of size should be drawn on the nearest LeTourneau Distributor or branch. Invoices will be received from and payment should be made to the Distributor on which orders are drawn.

When ordering parts by wire, **ALWAYS** show the order number. It may be necessary to refer to the order later, and we can give immediate information if a specific number is assigned to each order. A written confirmation of all wire, phone, and cable orders should be mailed the same day and should be marked "CONFIRMATION" to prevent duplication of orders.



## TRANSPORTATION

Parts will move on Government bill of lading if same is furnished. In all other cases parts will be shipped by means directed in the order, or by most economical means if no directions are given.

When Government bill of lading is not furnished, and no specific shipping instructions are given, transportation charges from Distributor's store, factory parts depot, or factory on which order is placed will be prepaid to destination and billed as a separate item on the invoice supported by receipted bill for transportation charges.

**UNDER NO CIRCUMSTANCES WILL TRANSPORTATION CHARGES BE MERGED WITH PARTS PRICES.** Parts prices thus inflated will not check against the contract price, and therefore will not pass audit in the General Accounting Office or elsewhere.

## PARTS TO BE RETURNED

Permission to return parts or equipment should be received before making shipment. When requesting return of parts or equipment, itemize and show invoice numbers and date of original purchase.

## FIELD OFFICERS:

We are assured by the Treasury Department that transportation as above can and should be paid. Please refrain from ordering parts from this schedule if you cannot pay transportation, for in such cases the charges become a claim in the G. A. O., involving much effort, delay and expense before they are recovered. Before refusing to pay transportation charges please communicate with your Department at Washington, D. C., with copy to R. G. LeTourneau, Inc., Peoria, Illinois.

## IMPORTANCE OF SERIAL NUMBERS

Serial numbers of equipment should be given on all parts orders not intended for stock. This is especially important for Power Control Unit spline shafts, ANGLEDOZER and Bulldozer A-Frame link bars, trunnion brackets, sheave housings, wheels, axles, gears, ROOTER shanks, shank points, and all large structures. When the equipment serial number is not given with the parts order, it is necessary that we wire for this information, with consequent delay to shipment.

## RIVETS

Rivets are furnished with all Power Control Unit cones and brake linings and are included in the price of the lining.

## WHEEL OIL SEAL

When ordering wheel oil seal retainers, oil seals should also be added to the order when the shipment is being made direct to the contractor.

Prices, weights, and specifications are subject to change without notice.

*Peoria, Ill.* • **R. G. LeTOURNEAU, Inc.** • *Stockton, Calif.*

CABLE ADDRESS "BOBLETORNO"

# MODEL "T4" POWER CONTROL UNIT PAGE 1

FOR MODEL D4 CATERPILLAR TRACTOR

## PARTS PRICE LIST

PART No.	Qty.	DESCRIPTION	PRICE	WEIGHT	
			EACH	LBS.	OZ.
C-3	2	TIMKEN BEARING CUP No. 44348	\$ 1.30	—	8
C-4	2	TIMKEN BEARING CUP No. 55443	2.20	1	12
C-5	2	TIMKEN BEARING CUP No. 414	1.43	—	12
C-7	8	TIMKEN BEARING CONE No. 559	4.56	2	10
C-8	8	TIMKEN BEARING CUP No. 552-A	3.39	1	10
C-9	2	REAR PLATE CAP	1.30	2	—
C-40	2	MANVILLE CLUTCH LINING	5.56	2	4
C-51	2	BRAKE SPRING	1.69	1	12
C-63	1	SHEAVE HOUSING	11.25	20	—
C-64	1	SHEAVE HOUSING	11.16	20	—
C-65	1	DOUBLE DECK SHEAVE BRACKET	77.73	109	—
C-66	2	DUST SEAL	.76	—	—
C-67	2	TIMKEN BEARING CONE No. 44150	2.87	1	—
C-68	4	TIMKEN BEARING CONE No. 55200	3.73	1	4
C-69	4	ADJUSTING NUT	3.30	2	—
C-70	2	TIMKEN BEARING CONE No. 418	2.68	1	—
C-71	2	SPRING	.66	—	6
C-83	2	CABLE DRUM	28.50	40	—
C-137	4	SHEAVE WHEEL	5.28	15	—
C-138	4	SHEAVE PIN	2.65	6	—
C-143	2	MAIN GEAR	54.18	57	—
C-175	4	BEARING (HYATT No. RA-212)	2.38	1	8
C-190	2	DRIVEN CONE	42.20	38	—
C-192	2	MANVILLE BRAKE LINING	2.29	1	8
C-196	2	SPRING	.51	—	4
C-218	8	LINK	.26	—	6
C-312	4	LOCKWASHER	.01	—	—
C-315	4	1/8" GREASE FITTING (LINCOLN No. 5000)	.06	—	—
C-318	24	CAPSCREW	.10	—	—
C-337	2	BEARING RACE (HYATT WOR-208)	1.35	—	12
C-1034	2	OIL LEVEL & DRAIN PLUG	.17	—	12
C-1051	4	COTTER KEY	.06	—	4
C-1524	6	1/2" NF HEX NUT	.03	—	—
C-1525	6	5/8" NC HEX NUT	.04	—	—
C-1527	10	3/4" NC HEX NUT	.05	—	—
C-1529	4	7/8" NC HEX NUT	.08	—	—
C-1539	34	3/8" LOCKWASHER	.01	—	—
C-1540	4	1/2" LOCKWASHER	.01	—	—
C-1541	48	5/8" LOCKWASHER	.02	—	—
C-1542	10	3/4" LOCKWASHER	.03	—	—
C-1543	4	7/8" LOCKWASHER	.05	—	—
C-1555	22	5/32"x1" COTTER KEY	.01	—	—
C-1558	1	3/8"x3/2" COTTER KEY	.05	—	—
C-1565	2	7/16"x6" MACH. BOLT	.11	—	8
C-1596	8	1/8"x60° GREASE FITTING	.10	—	—
C-1601	34	3/8"x3/4" NC CAPSCREW	.03	—	—
C-1613	24	1/2"x1 1/4" NC CAPSCREW	.06	—	—
C-1615	4	1/2"x1 3/4" NC CAPSCREW	.06	—	—
C-1629	18	5/8"x1 3/4" NC CAPSCREW	.11	—	4
C-1630	6	5/8"x2" NC CAPSCREW	.12	—	4
C-1634	6	5/8"x3" NC CAPSCREW	.15	—	4
C-1646	6	3/4"x2 1/2" NC CAPSCREW	.18	—	8
C-1648	2	3/4"x3" NC CAPSCREW	.20	—	8
C-1651	2	3/4"x3 3/4" NC CAPSCREW	.23	—	8
C-1687	4	1/2"x3 1/2" NF CAPSCREW	.12	—	4
C-1690	2	1/2"x4 1/4" NF CAPSCREW	.14	—	4
C-5572	2	7/16" NC HEX NUT	.03	—	—
C-5789	48	RIVETS FOR MANVILLE LINING FOR CONE	.80C	—	—

# MODEL "T4" POWER CONTROL UNIT

## PARTS PRICE LIST

2

PART No.	Qty.	DESCRIPTION	PRICE EACH	WEIGHT	
				LBS.	OZ.
C-5793	42	RIVETS FOR MANVILLE LINING FOR BRAKE		—	—
C-6507	1	LEFT CABLE GUARD	.80C	—	—
C-6508	1	RIGHT CABLE GUARD	7.55	22	—
C-7642	2	7/8" x 3 1/2" NC CAPSCREW	7.55	22	—
C-7643	2	7/8" x 4 1/2" NC CAPSCREW	.36	—	12
C-8310	1	FILL PLUG	.43	1	—
			.23	—	8
D-2378	1	HYATT BEARING No. 1208-TS	2.63	—	12
D-2613	24	VELVETOUCH LINING FOR BRAKE	8.19	3	8
D-2614	6	VELVETOUCH LINING FOR CONE	16.52	5	8
D-2721	1	REDUCTION GEAR	31.23	21	—
D-2889	24	1/2" SHAKEPROOF LOCKWASHER	.01	—	—
D-3528	1	HYATT ROLLER BEARING No. RA-307	1.75	—	12
D-3679	96	RIVET FOR VELVETOUCH BRAKE LINING	1.80C	—	—
D-3930	2	DRIVING CONE LINED WITH MANVILLE BRAKE LINING	26.65	26	—
D-3932	2	COVER PLATE	9.52	11	12
D-3959	2	"ROLLER BEARING CORP" NEEDLE BEARING No. 8446	5.59	1	4
D-4186	1	"T4" NECK STRUCTURE	47.50	120	—
D-4322	2	BRAKE SHAFT NUT	.37	—	8
D-4377	1	BUSHING	5.38	5	—
D-4431	4	FELT SEAL	.26	—	4
D-4433	2	THROW NUT BUSHING	2.85	1	12
D-4476	1	RIGHT THROW NUT	13.96	4	4
D-4477	1	LEFT THROW NUT	13.96	4	4
D-4509	1	RIGHT BRAKE SHAFT	3.89	5	8
D-4510	1	LEFT BRAKE SHAFT	3.89	5	8
D-4534	8	BRAKE LINK PIN	.25	—	2
D-4535	2	BRAKE SPRING ARM PIN	.25	—	2
D-4890	1	SPLINE SHAFT	22.28	17	—
D-4894	1	NECK BOSS	1.54	1	4
D-4904	1	BEARING SHAFT	2.86	4	4
D-5133	2	SET SCREW	.16	—	4
D-6387	2	FOOT SHIM	.10	—	—
D-6394	4	CAPSCREW	.26	—	4
D-6538	8	SPACER	.10	—	—
D-7054	2	BRAKE BAND LINED WITH VELVETOUCH LINING	15.75	6	—
D-7134	2	BRAKE BAND LINED WITH MANVILLE	9.89	5	8
D-7136	4	TIMKEN BEARING ASSEMBLY D-4429-D4432	1.79	—	10
D-7348	2	DRIVING CONE LINED WITH VELVETOUCH LINING	37.63	30	—
D-8493	1	REAR PLATE	16.90	50	—
D-9484	1	DRAW BAR	13.75	50	—
D-9486	1	BRACKET FOR DRAWBAR	13.75	50	—
E-229	4	CABLE GUARD SHIM	.10	—	—
E-4132	2	COTTER KEY	.01	—	—
E-4614	1	RIGHT CABLE DRUM ASSEMBLY	114.58	110	—
E-4615	1	LEFT CABLE DRUM ASSEMBLY	114.58	110	—
E-5251	2	PLUG	.05	—	—
E-6193	1	PIN	1.30	2	—
E-6293	1	TOP RIGHT SHEAVE HOUSING	11.25	20	—
E-6294	1	BOTTOM LEFT SHEAVE HOUSING	11.25	20	—
E-6687	1	HYATT BEARING No. RAW-208	1.69	—	12
E-8617	—	.014 SHIM	.10	—	—
E-8618	—	.007 SHIM	.10	—	—

## MODEL "T4" POWER CONTROL UNIT

3

## PARTS PRICE LIST

PART No.	Qty.	DESCRIPTION	PRICE EACH	WEIGHT	
				LBS.	OZ.
F-267	2	ROLLER .....	.73	1	4
F-268	2	ROLLER PIN .....	.31	—	4
F-416	1	RIGHT DRUM SHAFT .....	24.18	27	4
F-417	1	LEFT DRUM SHAFT .....	24.18	27	4
L-21	1	OIL SEAL (CHICAGO RAWHIDE SPECIAL) .....	1.36	—	4
L-323	1	DUST SEAL (CHICAGO RAWHIDE SPECIAL) .....	.50	—	2
L-1624	3	OIL SEAL (CHICAGO RAWHIDE No. 354216) .....	.66	—	4
L-3725	2	OIL SEAL (CHICAGO RAWHIDE SPECIAL) .....	.60	—	3
L-37050	2	OIL SEAL (CHICAGO RAWHIDE SPECIAL) .....	7.35	2	—
H-2824	1	CASE TO NECK GASKET .....	.65	—	—
H-2825	2	COVER GASKET .....	.65	—	—
H-3348	2	LEVER .....	1.03	3	—
H-3349	2	ROLLER ASSEMBLY .....	2.08	5	—
H-3500	2	BRAKE ARM .....	.78	1	4
H-3505	1	CASE STRUCTURE .....	99.83	193	—
H-3730	2	SPRING CLIP .....	.16	—	2
H-3743	1	RIGHT HANDLE STRUCTURE .....	5.35	14	—
H-3744	1	LEFT HANDLE STRUCTURE .....	5.38	15	—
H-7071	72	RIVETS FOR VELVETOUCH CONE LINING .....	2.50C	—	—
H-8524	4	CAPSCREW .....	.04	—	—
30-G	1	FACE PLATE GASKET .....	.35	—	—