

FINAL DRIVE INTERMEDIATE SHAFT

ITEM	PART NUMBER	QTY.	DESCRIPTION	PACKAGE NUMBER
1	050275	2	CUP, inner bearing	
2	064200	2	CONE ASSEMBLY, inner bearing	
3	068501	2	GEAR (44 teeth)	
4	049829	4	LOCK, gear retaining	
5	035244	4	CAPSCREW, 3/8"NC x 3/4"	
6	049936	4	LOCK, capscrew	
7	051246	2	SHAFT	
8	049886	2	PINION (20 teeth)	
9	051438	2	CONE ASSEMBLY, outer bearing	
10	051347	2	CUP, outer bearing	
11	051450	4	SHIM, bearing adjustment (.005" thick. Use as req'd)	
	051448	4	SHIM, bearing adjustment (.007" thick. Use as req'd)	
	051449	10	SHIM, bearing adjustment (.010" thick. Use as req'd)	
12	051243	2	COVER, outer bearing	
13	013058	12	CAPSCREW, 3/8"NC x 1-1/4"	
	904206	12	LOCKWASHER, 3/8"	

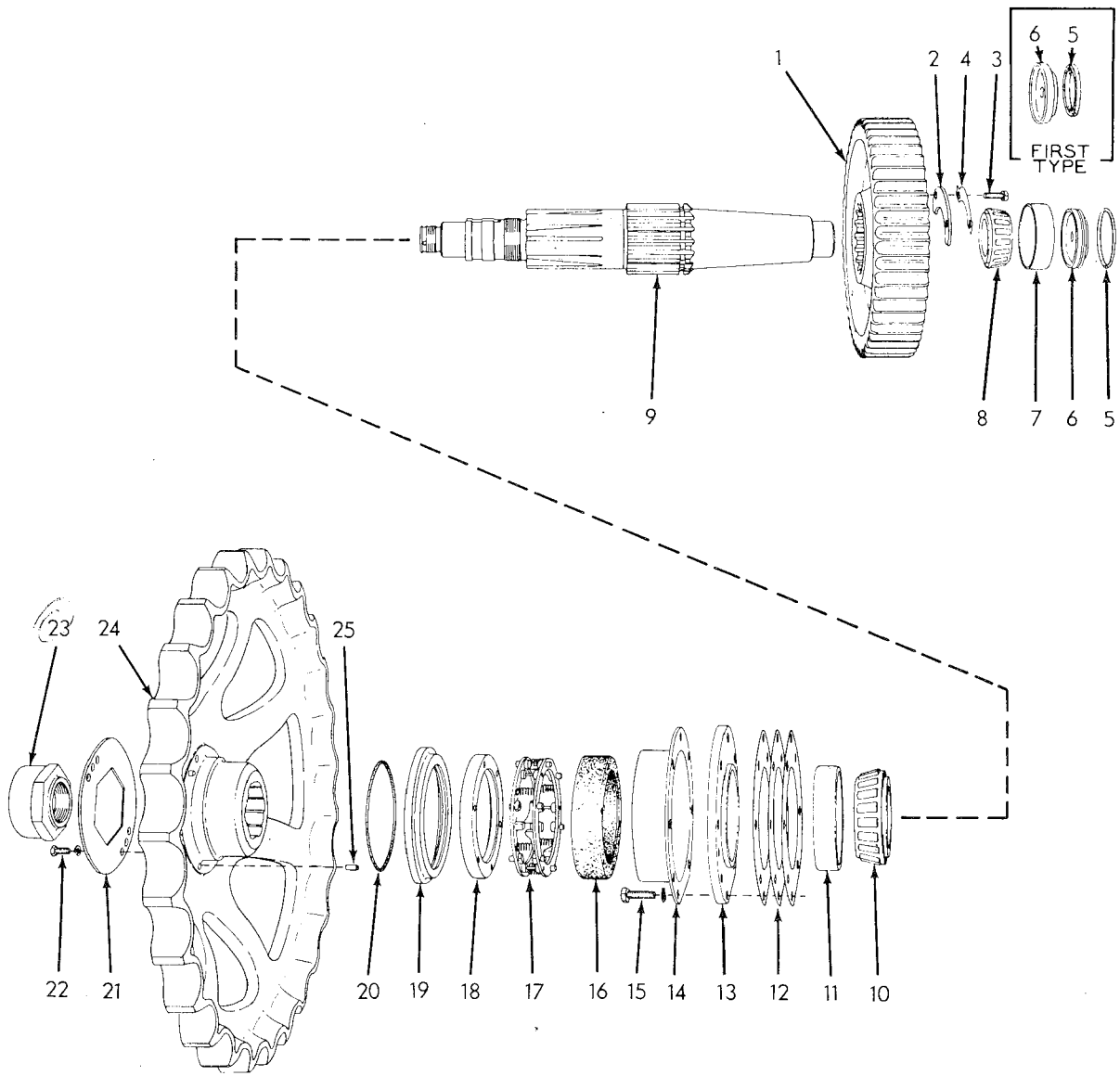

FINAL DRIVE SPROCKET, SHAFT AND GEAR

FINAL DRIVE SPROCKET SHAFT AND GEAR

\* Used prior to tractor serial No. 8906  
 \*\* Effective with tractor serial No. 8906

ITEM	PART NUMBER	QTY.		DESCRIPTION	PACKAGE NUMBER
		*	**		
1	051400	2	2	GEAR (51 teeth)	
2	051395	2	2	LOCK, gear retaining	
3	036034	4	4	CAPSCREW, 3/8"NF x 1"	
4	051396	2	2	LOCK, capscrew	
5	{ 051238	2	-	SEAL, shaft end cover (1/4" thick)(Used prior to tractor #3491)	
	{ 034108	2	2	RING, sealing, shaft end cover (1/8" thick)(Effective with tractor #3491)	
6	{ 049834	2	-	COVER, shaft end, inner (Used prior to tractor #3491)	
	{ 091325	2	2	COVER, shaft end, inner (Effective with tractor #3491)	
7	210740	2	2	CUP, inner bearing	
8	043491	2	2	CONE ASSEMBLY, inner bearing	
9	{ 080954	2	2	SHAFT, track sprocket (6 splines)(Original equipment)	
	{ 621238	2	2	SHAFT, track sprocket (20 splines)(Service replacement only)	
10	{ 050278	2	2	CONE ASSEMBLY, intermediate bearing (3-1/4" I.D.) (Original equipment)	
	{ 054246	2	2	CONE ASSEMBLY, intermediate bearing (3-3/8" I.D.) (Service replacement only. Used with 20-spline shaft only)	
11	050276	2	2	CUP, intermediate bearing	
12	{ 051240	4	4	SHIM, bearing adjustment (.005" thick. Use as req'd)	
	{ 051241	4	4	SHIM, bearing adjustment (.007" thick. Use as req'd)	
	{ 051242	16	16	SHIM, bearing adjustment (.010" thick. Use as req'd)	
13	051244	2	2	RETAINER, intermediate bearing	
14	049851	2	2	GUARD, inner seal	
15	035190	16	16	CAPSCREW, 1/2"NC x 1-1/2"	
	904208	16	16	LOCKWASHER, 1/2"	
16	049826	2	2	BOOT, inner seal . . . . .	073762 096278
17	049825	2	2	FOLLOWER ASSEMBLY, inner seal (Serviced only as a unit) . . . . .	073762 096278
18	{ 082883	2	-	RING, inner seal (stationary. 5" I.D.) . . . . .	073762
	{ 096158	-	2	RING, inner seal (stationary, 5-3/16" I.D.) . . . . .	096278

(Continued)

(Revised February 1961)

FINAL DRIVE SPROCKET SHAFT AND GEAR (Continued)

ITEM	PART NUMBER	QTY. * **	DESCRIPTION	PACKAGE NUMBER
19	082859	2 -	RING, inner seal (rotating, 6-13/16"O.D.) . . . . .	073762
	096159	- 2	RING, inner seal (rotating, 7-1/2"O.D.) . . . . .	096278
20	053594	2 -	RING, packing, seal ring (rubber, 5-5/16"O.D.) . . . . .	073762
	096160	- 2	RING, packing, seal ring (rubber, 5-7/8"O.D.) . . . . .	096278
21	049853	2 -	LOCK, sprocket retaining nut (6-3/8"O.D., 3-3/4"hex) (Original equipment)	
	096155	- 2	LOCK, sprocket retaining nut (7-3/4"O.D., 3-3/4" hex) (Original equipment)	
	621243	2 2	LOCK, sprocket retaining nut (4" hex)(Service re- placement. Used with 20-spline sprocket only)	
22	035439	4 4	CAPSCREW, 3/8"NC x 1"	
	904206	4 4	LOCKWASHER, 3/8"	
23	081369	2 2	NUT, sprocket retaining (Original equipment)	
	621241	2 2	NUT, sprocket retaining (Service replacement. Used with 20-spline sprocket only)	
24	049817	2 -	SPROCKET ASSEMBLY, track (Includes item 25)(Stand- ard. Has 5" diam. hub with 6 splines and wide tooth- base)(Original equipment)	
	096146	- 2	SPROCKET ASSEMBLY, track (Includes item 25)(Stand- ard. Has 5-3/16" diam. hub with 6 splines and wide tooth-base)(Original equipment)	
	621237	2 2	SPROCKET ASSEMBLY, track (Includes item 25)(Service replacement. Has 20 splines and wide tooth base)	
	056188	2 -	SPROCKET ASSEMBLY, track (Includes item 25)(Special. Has 5" diam. hub with 6 splines and narrow tooth-base to minimize packing of track)	
	096167	- 2	SPROCKET ASSEMBLY, track (Includes item 25)(Special. Has 5-3/16" diam. hub with 6 splines and narrow tooth- base to minimize packing of track)	
	621225	2 2	SPROCKET ASSEMBLY, track (Includes item 25)(Service replacement. Has 20 splines and narrow tooth-base to minimize packing of track)	
	097960	2 2	SPROCKET RIM, only (Standard type. Requires welding to install)	
25	042930	6 6	PIN, driving, inner seal ring	
26	033288	- -	CEMENT, neoprene, 1/2 pt. can	} For cementing seal boots
27	054890	- -	SOLVENT, neoprene, cement, 1/2 pt. can	

621214

(Added February 1961)

100

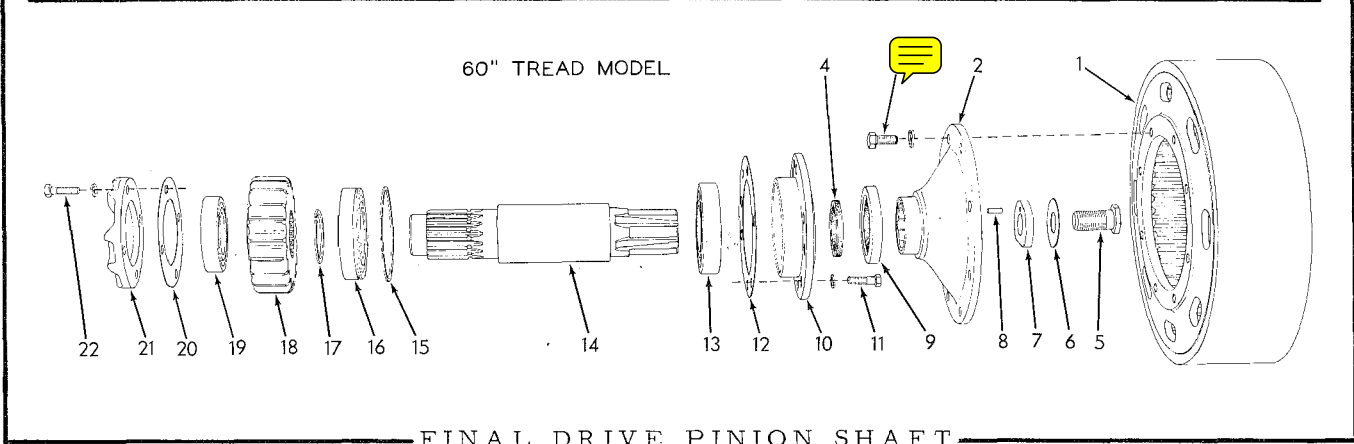
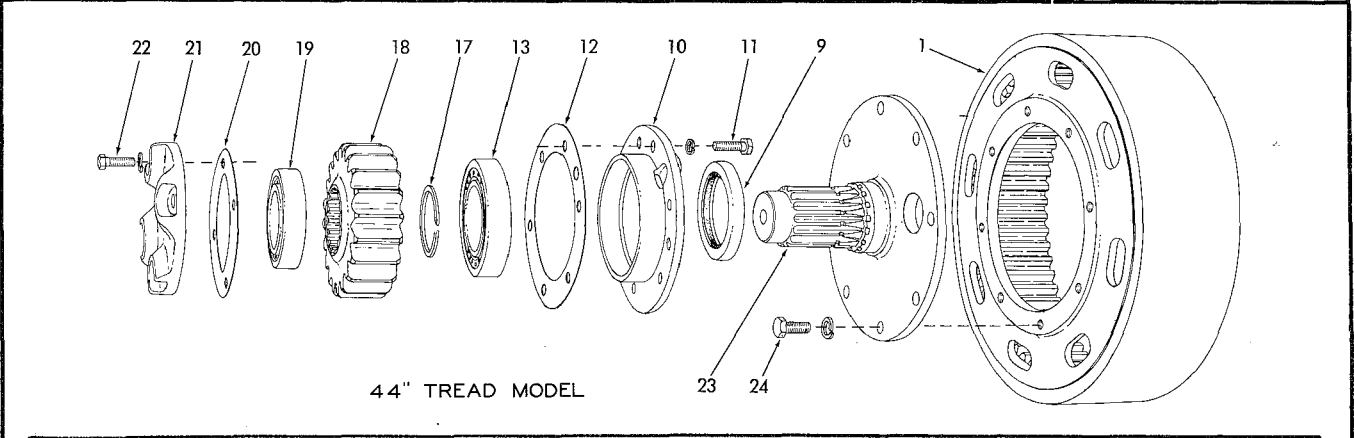

*Assess  
801-972-7326  
Subs Out  
M*

FINAL DRIVE PINION SHAFT

\* 44" tread Models  
 \*\* 60" tread Models

ITEM	PART NUMBER	QTY.		DESCRIPTION	PACKAGE NUMBER
		*	**		
1	050216	2	2	DRUM, brake	
2	049937	-	2	HUB, brake drum	
3	035221	-	16	CAPSCREW, 1/2"NC x 1"	
	904208	-	16	LOCKWASHER, 1/2"	
4	050264	-	2	SEAL, oil (neoprene)	
5	050226	-	2	CAPSCREW, hub retaining (1"NF x 1-3/4")	
6	050225	-	2	WASHER, locking, hub retaining capscrew	
7	064520	-	2	WASHER ASSEMBLY, hub retaining (Includes item 8)	
8	035793	-	2	PIN, hub retaining washer	
9	053670	2	2	SEAL, oil	
10	049820	2	2	CAGE, inner bearing	
11	922211	12	12	CAPSCREW, Nylok, 3/8"NC x 1-1/4"	
	904206	12	12	LOCKWASHER, 3/8"	
12	051245	2	2	GASKET, inner bearing cage . . . . .	069625
13	050274	2	2	BEARING, roller, inner	
14	049945	-	2	SHAFT	
15	040831	-	2	RING, snap, intermediate bearing	
16	063912	-	2	BEARING, roller, intermediate	
17	049899	2	2	RING, snap, pinion shaft	
18	049881	2	2	PINION (20 teeth)	
19	050273	2	2	BEARING, roller, outer	
20	049903	2	2	GASKET, outer bearing cover . . . . .	069625
21	049818	2	2	COVER, outer bearing	
22	013058	8	8	CAPSCREW, 3/8"NC x 1-1/4"	
	904206	8	8	LOCKWASHER, 3/8"	
23	049822	2	-	HUB, brake drum	
24	207781	16	-	CAPSCREW, 1/2"NC x 1" (thin head)	
	904208	16	-	LOCKWASHER, 1/2"	

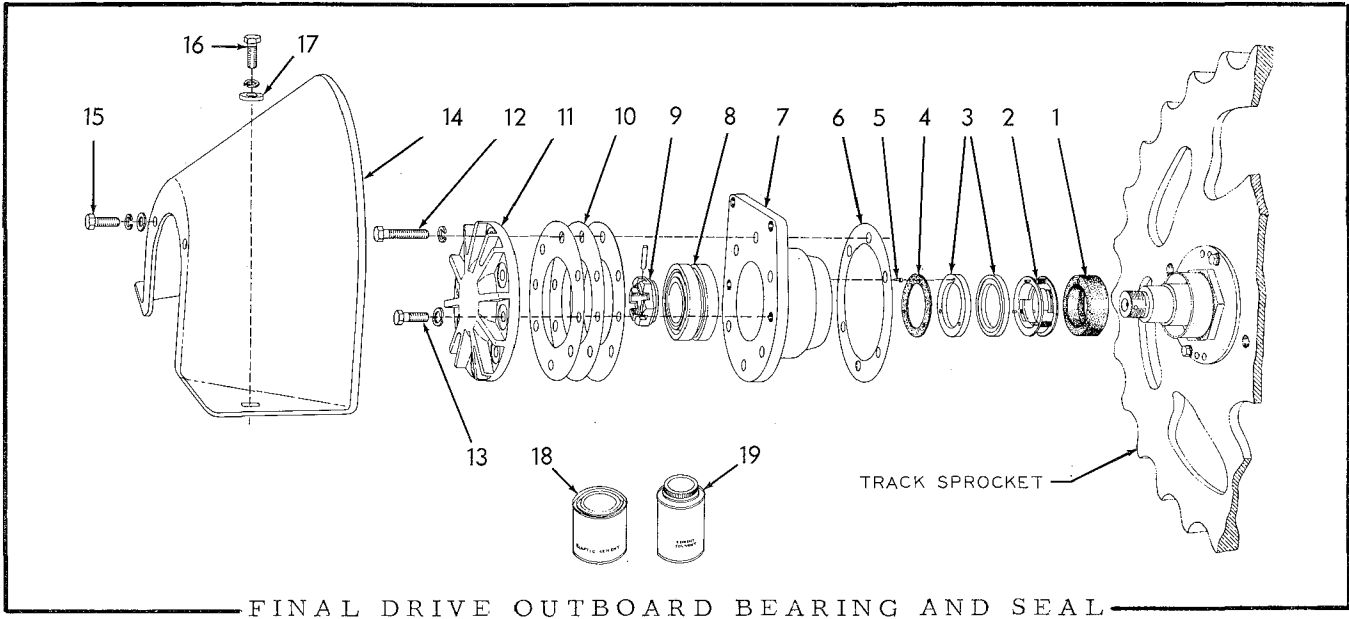

FINAL DRIVE OUTBOARD BEARING AND SEAL

\* Original equipment  
 \*\* Service replacement. Used with 20-spline track sprocket only

ITEM	PART NUMBER	QTY. * **	DESCRIPTION	PACKAGE NUMBER
1	049109	2 -	BOOT, seal	073763
	051112	- 2	BOOT, seal	088665
2	049111	2 -	SPRING ASSEMBLY, seal (Serviced only as a unit)	073763
	051121	- 2	SPRING ASSEMBLY, seal (Serviced only as a unit)	
3	049110	4 -	RING, seal	073763
	051124	- 4	RING, seal	088665
4	049836	2 -	GASKET, seal ring	073763
	051125	- 2	GASKET, seal ring	088665
5	081194	12 12	STUD, locating, seal ring (Rivets to cage)	
6	085726	12 12	SHIM, outboard bearing cage (.015" thick. Use as req'd)	
7	085834	2 -	CAGE ASSEMBLY, outboard bearing (Includes item 5)	
	621245	- 2	CAGE ASSEMBLY, outboard bearing (Includes item 5)	
8	080101	2 2	BEARING, roller (Each consists of 1 roller assembly and cups. Serviced only as a unit)	
	→ 629354			74 25
9	081242	2 2	NUT, retaining, outboard bearing	
	915513	2 2	PIN, roll, 1/4" x 3/4"	

(Continued)

(Revised February 1961)



FINAL DRIVE OUTBOARD BEARING AND SEAL (Continued)

ITEM	PART NUMBER	QTY.		DESCRIPTION	PACKAGE NUMBER
		*	**		
10	085827	4	4	SHIM, bearing adjustment (.005" thick. Use as req'd)	
	085829	4	4	SHIM, bearing adjustment (.007" thick. Use as req'd)	
	085828	10	10	SHIM, bearing adjustment (.010" thick. Use as req'd)	
11	085831	2	2	CAP, outboard bearing	
12	035068	12	12	CAPSCREW, 1/2"NF x 2-1/4"	
13	035525	4	4	CAPSCREW, 1/2"NF x 1-1/8"	
	904208	16	16	LOCKWASHER, 1/2"	
14	085832	2	2	GUARD, track sprocket (Special equipment)	
15	070469	4	4	CAPSCREW, 1/2"NF x 1-1/4"	
	900818	4	4	WASHER, plain, U.S. std., 1/2"	
16	614478	4	4	CAPSCREW, 1/2"NF x 1-3/8"	
	904208	8	8	LOCKWASHER, 1/2"	
17	064531	4	4	WASHER, plain	
18	033288	-	-	CEMENT, neoprene, 1/2 pt. can	} For cementing boots and gaskets
19	054890	-	-	SOLVENT, neoprene cement, 1/2 pt. can	

(Added February 1961)