

CLUTCH

REF. NO.	PART NUMBER	DESCRIPTION	REF. NO.	PART NUMBER	DESCRIPTION
----------	-------------	-------------	----------	-------------	-------------

ENGINE OVER-CENTER CLUTCH, 13"
 (Hand Operated) (Rockford Drilling Machine) (Used on Manual Shift, Agr., Revolving Crane and Sideboom Tractors)

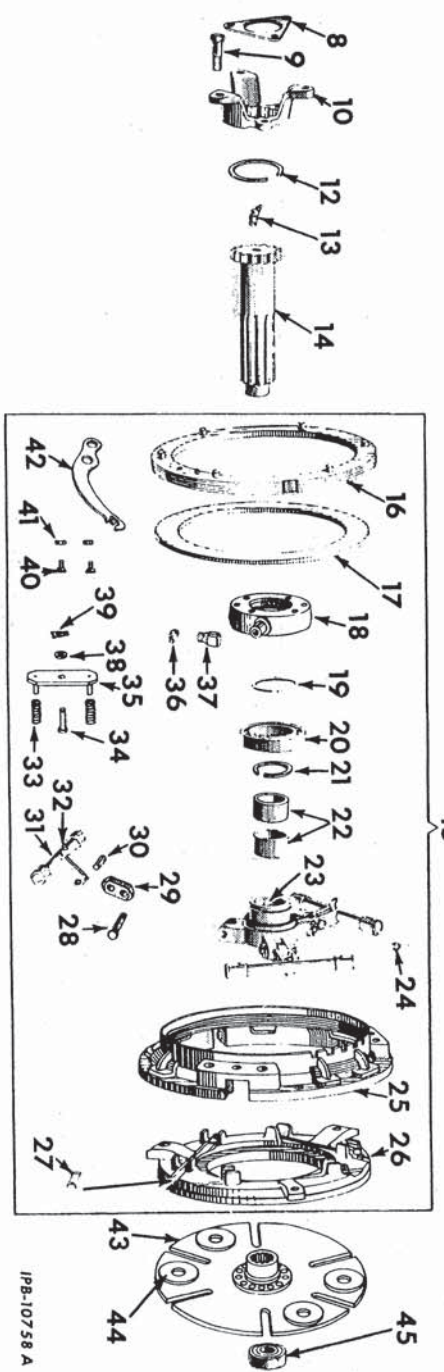
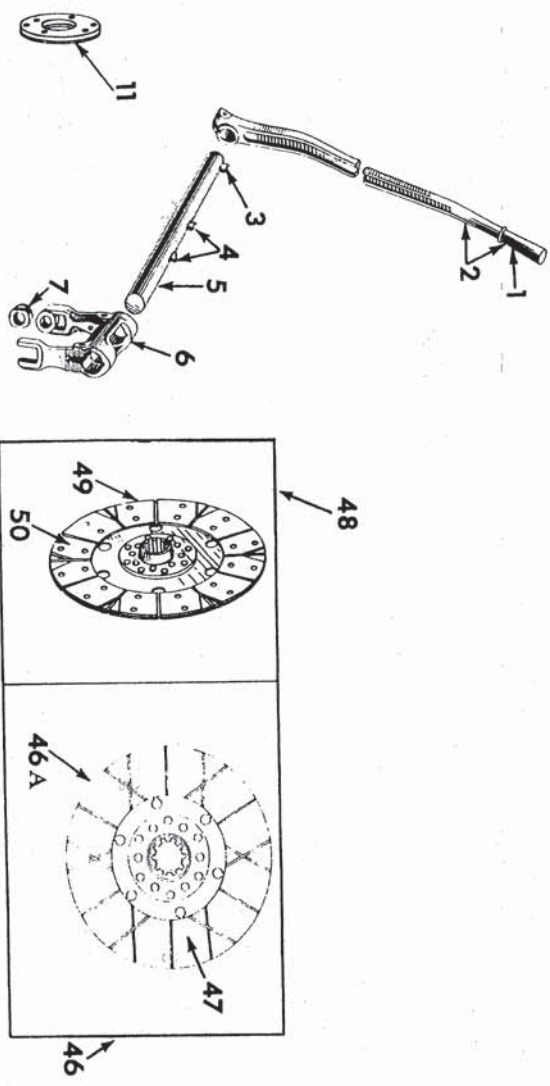

IPB-10758 A

1	619 405 C1	HANDLE, engine clutch hand lever	5	53 494 D	SHAFT, engine clutch release
2	303 536 R11	LEVER w/HANDLE, 619 405 C1, engine clutch hand (for Revolving Crane and Sideboom Tractors)	6	8 247 DB 181 374	FORK, engine clutch release SCREW, 3/8 NF x 1-1/2", hex-hd cap (2)
2	275 227 R11	LEVER w/HANDLE, 619 405 C1, engine clutch hand (for Manual Shift and Agr. Tractors)	7	103 321	WASHER, 3/8" lock (2)
	103 028	NUT, 1/2 NF	8	51 227 DB	BUSHING, engine clutch release pin (2)
	181 436	SCREW, 1/2 NF x 2-1/2", hex-hd		259 688 R1	PLATE, engine clutch shaft end
	103 323	WASHER, 1/2" lock		181 343	SCREW, 5/16 NF x 1/2", hex-hd cap (3)
3	103 909	KEY, 1/4 x 1-1/8" (WOODRUFF) (engine clutch hand lever)		103 320	WASHER, 5/16" lock (3)
4	103 462	KEY, 3/16 x 1" (WOODRUFF) (engine clutch release fork) (2)	9	54 969 D 271 505 103 322	BOLT, engine clutch coupling dowel (3) NUT, 7/16 NF (3) WASHER, 7/16" lock (3)

CLUTCH

REF. NO.	PART NUMBER	DESCRIPTION	REF. NO.	PART NUMBER	DESCRIPTION
ENGINE OVER-CENTER CLUTCH, 13" - Continued (Hand Operated) (Rockford Drilling Machine) (Used on Manual Shift, Agr., Revolving Crane and Sideboom Tractors)					
10	266 457 R11	COUPLING, engine clutch	35	304 787 R91	STOP, return spring (3)
11	317 861 R1	FACING, brake clutch bearing (optional with 317 862 R1)	36	273 347	FITTING, engine clutch release bearing lubrication
11	317 862 R1	FACING, brake clutch bearing (optional with 317 861 R1)	37	191 759	ADAPTER, engine clutch release bearing lubrication fitting, angle elbow (optional with 145 017 H)
12	266 458 R1	RING, engine clutch coupling snap	37	145 017 H	ADAPTER, engine clutch release bearing lubrication fitting, angle elbow (optional with 191 759)
13	109 460	FITTING, engine clutch pilot bearing lubrication	38	615 029 R1	WASHER, return spring retaining pin (3)
14	266 459 R1	SHAFT, engine clutch	39	267 689 R1	"X" WASHER, return spring retaining pin (3)
15	317 859 R93 179 883	CLUTCH ASSY, less driven member SCREW, 1/2 x 1-1/4", hex-hd cap (6)	40	61 115 D	SCREW, adjusting ring lock (2)
	103 323	WASHER, 1/2" lock (6)	41	103 026	NUT, 3/8" NF (2)
16	55 371 DA	RING, adjusting	42	264 679 R1	LOCK, adjusting ring
17	31 238 DA	PLATE, adjusting ring	43	702 537 C91	MEMBER w/eight FACING, and four RIVET, 338 360 R1, ceramic-like driven (will work for MEMBER, 324 999 R1)
18	317 860 R91	CARRIER w/FACING and six RIVET, 96 189 R1, throw-out bearing	44	702 550 C1	PACKAGE, driven member, ceramic-like facing field service (consists of two cerametallic FACING and RIVET, 338 360 R1) (6)
19	29 780 D	RING, snap	45	ST 211	RIVET, special (CL-10858-1) (4)
20	972 386 R91	BEARING, throw-out ball	46	604 644 C91	BEARING, clutch pilot ball
21	304 780 R1	RING, snap	46	604 644 C91	ATTACHMENT, semimetallic clutch driven member (see NOTES 1 and 3)
22	26 039 DA	BUSHING, release sleeve (2)	46A	277 675 R91	MEMBER, w/two FACING and twenty-six RIVET, 50 413 D, semimetallic driven
23	304 778 R92	SLEEVE w/two BUSHING, 26 039 DA, and FITTING, 126 121, release	47	277 676 R91	PACKAGE, semimetallic clutch facing field service (consists of two semimetallic FACING and twenty-six RIVET, 50 413 D)
24	126 121	FITTING, release sleeve lubrication	48	331 204 R91	RIVET, clutch facing (26)
25	304 776 R1	PLATE, back	49	313 531 R92	ATTACHMENT, bimetallic driven member (see NOTES 1 and 3)
26	304 777 R1	PLATE, pressure	49	313 531 R92	MEMBER, w/two FACING and twenty-six RIVET, 250 263 R1, bimetallic driven
27	267 665 R91 261 106 R1	BLOCK, cam (set of 6) SCREW, hex-hd cap WASHER, 1/4" external-tooth lock (6)	48	331 204 R91	ATTACHMENT, bimetallic driven member (see NOTES 1 and 3)
28	324 561 R91	PACKAGE, connecting link pin field service (consists of PIN, WASHER and "X" WASHER) (3)	49	313 531 R92	MEMBER, w/two FACING and twenty-six RIVET, 250 263 R1, bimetallic driven
29	304 782 R1	LINK, connecting (3)			
30	304 784 R2	PIN, connecting link (short) (3)			
31	702 390 C1	CAMSHAFT w/three FITTING, 109 460 (set of 3)			
32	109 460	FITTING, camshaft lubrication (9)			

NOTE 1 - Factory Application -
Order on Machine Order
Form.

NOTE 3 - Field Application - Order
Through Regular Service
Parts Channels.

CLUTCH

REF. NO.	PART NUMBER	DESCRIPTION	REF. NO.	PART NUMBER	DESCRIPTION
ENGINE OVER-CENTER CLUTCH, 13" - Continued (Hand Operated) (Rockford Drilling Machine) (Used on Manual Shift, Agr., Revolving Crane and Sideboom Tractors)					
50	313 530 R92	PACKAGE, bimetallic driven member field service (consists of two bimetallic FACING and twenty-six RIVET, 250 263 R1) (2)			
	250 263 R1	RIVET, clutch facing (26)			
	324 549 R91	PACKAGE, clutch brake facing field service (consists of FACING and eight RIVET) (for CARRIER, 317 860 R91) (optional with 324 560 R91)			
	324 560 R91	PACKAGE, clutch brake facing field service (consists of FACING and eight RIVET) (optional with 324 549 R91) (for CARRIER, 317 860 R91)			
	324 998 R91	PACKAGE, driven member cerametallic facing field service (consists of two cerametallic FACING, and RIVET, 338 360 R1) (2)			