

CLUTCH

ENGINE OVER-CENTER CLUTCH 13"
(Hand Operated) (Rockford Drilling Machine)

CLUTCH

ENGINE OVER-CENTER CLUTCH 13" - CONTINUED
(Hand Operated) (Rockford Drilling Machine)

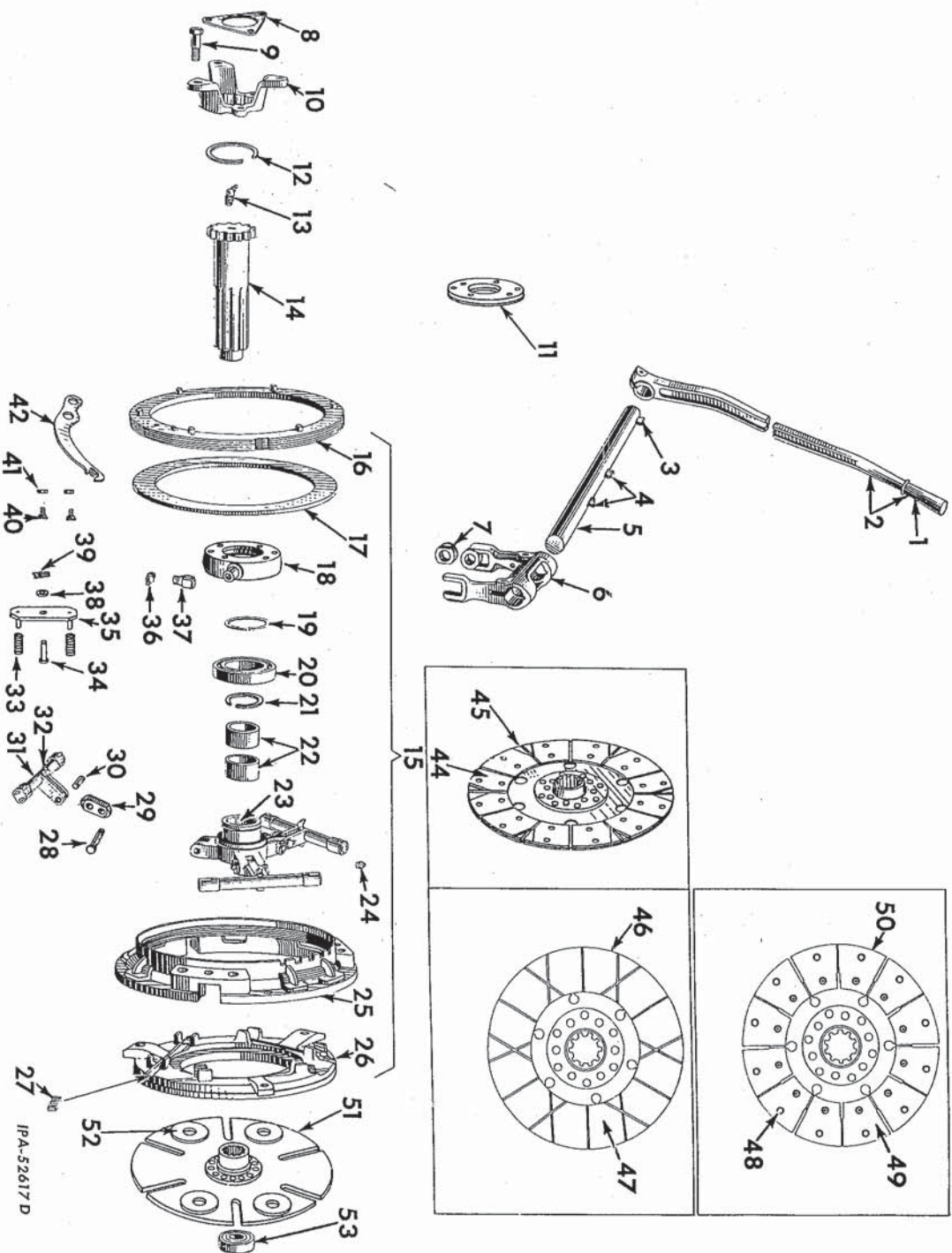

REF. NO.	I. H. PART NUMBER	DESCRIPTION	REF. NO.	I. H. PART NUMBER	DESCRIPTION
1	41 597 DA	HANDLE, engine clutch hand lever	8	259 688 R1	PLATE, engine clutch shaft end 5/16NF x 1/2" hex-hd. cap SCREW (3)
2	275 227 R11	LEVER w/HANDLE, 41 597 DA, engine clutch hand	9	54 969 D	BOLT, engine clutch coupling dowel (3) 7/16NF NUT (3) 7/16" lock WASHER (3)
3	103 909	KEY, 1/4 x 1-1/8" (Woodruff) (engine clutch hand lever)	10	266 457 R11	COUPLING, engine clutch
4	103 462	KEY, 3/16 x 1" (Woodruff) (engine clutch release fork) (2)	11	317 861 R1	FACING, brake clutch bearing (optional with 317 862 R1) (CL-11080-89)
5	53 494 D	SHAFT, engine clutch release	11	317 862 R1	FACING, brake clutch bearing (optional with 317 861 R1) (CL-11080-81)
6	8 247 DB	FORK, engine clutch release 3/8NF x 1-1/2" hex-hd. cap SCREW (2) 3/8" lock WASHER (2)	12	266 458 R1	RING, engine clutch coupling snap
7	51 227 DB	BUSHING, engine clutch release pin (2)			



CLUTCH

REF. NO.	I. H. PART NUMBER	DESCRIPTION
----------	-------------------	-------------

ENGINE OVER-CENTER CLUTCH 13" - CONTINUED
(Hand Operated) (Rockford Drilling Machine)

13	109 460	FITTING, engine clutch pilot bearing lubrication (Lincoln No. 5300) (optional with 271 284)
13	271 284	FITTING, engine clutch pilot bearing lubrication (Alemite No. 1612B) (optional with 109 460)
14	266 459 R1	SHAFT, engine clutch
15	317 859 R92	CLUTCH ASSEMBLY, less driven number (UCLA-4-10783) (will work for 304 775 R92) (Composed of -
	1	BEARING 972 386 R91
	1	BLOCK 267 665 R91
	1	CAMSHAFT 304 781 R92
	1	CARRIER 317 860 R91
	3	LINK 304 782 R1
	1	LOCK 264 679 R1
	1	PACKAGE 324 561 R91
	3	PIN 304 784 R2
	3	PIN 304 786 R1
	1	PLATE 31 238 DA
	1	PLATE 304 776 R1
	1	PLATE 304 777 R1
	1	RING 29 780 D
	1	RING 55 371 DA
	1	RING 304 780 R1
	1	SCREW 61 115 D
	1	SLEEVE 304 778 R92
	1	SPRING 304 785 R2
	6	STOP 304 787 R91
	3	STOP 267 689 R1
	6	WASHER 615 029 R1
	6	WASHER 267 689 R1
	1/2 x 1-1/4"	hex-hd. cap SCREW (6)
	1/2"	lock WASHER (6)
16	55 371 DA	RING, adjusting (CL-4815-1)
17	31 238 DA	PLATE, adjusting ring (CL-3461-5)
18	317 860 R91	CARRIER w/PACKAGE, 324 549 R91 and six RIVET 96 189 R1, throw out bearing (CL-10742-1) (will work for 304 779 R2)
19	29 780 D	RING, snap (CL-3302)
20	972 386 R91	BEARING, throw out ball (CL-6644)
21	304 780 R1	RING, snap (CL-10206)
22	26 039 DA	BUSHING, release sleeve (CL-3110) (2)
23	304 778 R92	SLEEVE w/two BUSHING, 26 039 DA and FITTING, 271 281, release (UCL-10741)
24	271 281	FITTING, release sleeve lubrication (Alemite No. 1607B) (optional with 126 121)
24	126 121	FITTING, release sleeve lubrication (Lincoln No. 5003) (optional with 271 281)
25	304 776 R1	PLATE, back (CL-10783)
26	304 777 R1	PLATE, pressure (CL-10776)
27	267 665 R91	BLOCK, cam (set of 6) (UCL-3478-2-56)
	261 106 R1	SCREW, hex-hd. cap (CL-3921) (6)
		1/4" external-tooth lock WASHER (6)
28	324 561 R91	PACKAGE, link pin field service (UCL-9314-4)
29	304 782 R1	LINK, connecting (ACL-10744) (3)
30	304 784 R2	PIN, connecting link (short) (CL-10745) (3)
31	304 781 R92	CAMSHAFT w/three FITTING, 271 284 (UCLB-4337-35-S3) (set of 3)
32	271 284	FITTING, camshaft lubrication (Alemite No. 1612B) (3)



CLUTCH

REF. NO.	I. H. PART NUMBER	DESCRIPTION
----------	-------------------	-------------

ENGINE OVER-CENTER CLUTCH 13" - CONTINUED
(Hand Operated) (Rockford Drilling Machine)

33	304 785 R2	SPRING, return (CL-10812-1A) (6)
34	304 786 R1	PIN, return spring retaining (CL-10813) (3)
35	304 787 R91	STOP, return spring (UCL-10814) (3)
36	273 347	FITTING, engine clutch release bearing lubrication
37	191 759	ADAPTER, engine clutch release bearing lubrication fitting angle elbow (optional with 145 017 H)
37	145 017 H	ADAPTER, engine clutch release bearing lubrication fitting angle elbow (optional with 191 759)
38	615 029 R1	WASHER, return spring retaining pin (CL-4347) (3)
39	267 689 R1	"X" WASHER, return spring retaining pin (CL-9318) (3)
40	61 115 D	SCREW, adjusting ring lock (CL-5215) (2)
41		NUT, 3/8NF (2)
42	264 679 R1	LOCK, adjusting ring (CL-9014)
44	324 998 R91	PACKAGE, driven member cerametallic facing field service (Consists of two cerametallic FACING and RIVET, 338 360 R1 (UCL-11415-90-CR2) (4) RIVET, special (CL-10858-1) (4)
45	324 999 R91	MEMBER w/eight FACING and four RIVET, 338 360 R1, cerametallic driven (UCL-71-4541)
46	277 675 R91	ATTACHMENT, semi-metallic driven clutch member (UCL-45-4541) (See NOTES 1 and 3)
47	277 676 R91	PACKAGE, field service clutch facing (semi-metallic) (consists of two clutch FACING and twenty-six RIVET, 50 413 D) (UCL-7796-14-CR2)
48	250 263 R1	RIVET, clutch facing (CL-1011-5) (26)
49	277 422 R91	PACKAGE, field service clutch facing (bi-metallic) (consists of two clutch FACING and twenty-six RIVET, 250 263 R1) (UCL-11290-13-CR2)
50	277 421 R91	ATTACHMENT, bi-metallic driven clutch member (UCL-67-4541) (See NOTES 1 and 3)
51	303 766 R92	MEMBER w/two FACING and twenty-six RIVET, 96 189 R1, driven (UCL-64-4541)
52	313 528 R92	PACKAGE, field service, ferritic facing (consists of two FACING and twenty-six RIVET, 350 263 R1) (UCL-11285-63-CR-2)
53	ST 211	BEARING, clutch pilot ball
	324 549 R91	PACKAGE, clutch brake facing field service (UCL-11080-81) (optional with 324 560 R91)
	324 560 R91	PACKAGE, clutch brake facing field service (UCL-11080-29) (optional with 324 549 R91)
	50 413 D	RIVET, clutch facing (CL-1011-5) (26)
	96 189 R1	RIVET, clutch bearing carrier (CL-60-58-1) (6)
	267 689 R1	"X" WASHER (connecting link pin) (CL-4347) (3)
	615 029 R1	WASHER (connecting link pin) (CL-9318) (3)
		NOTE 1 - Factory Application - Order on Machine Order Form.
		NOTE 3 - Field Application - Order through Regular Service Parts Channels.