

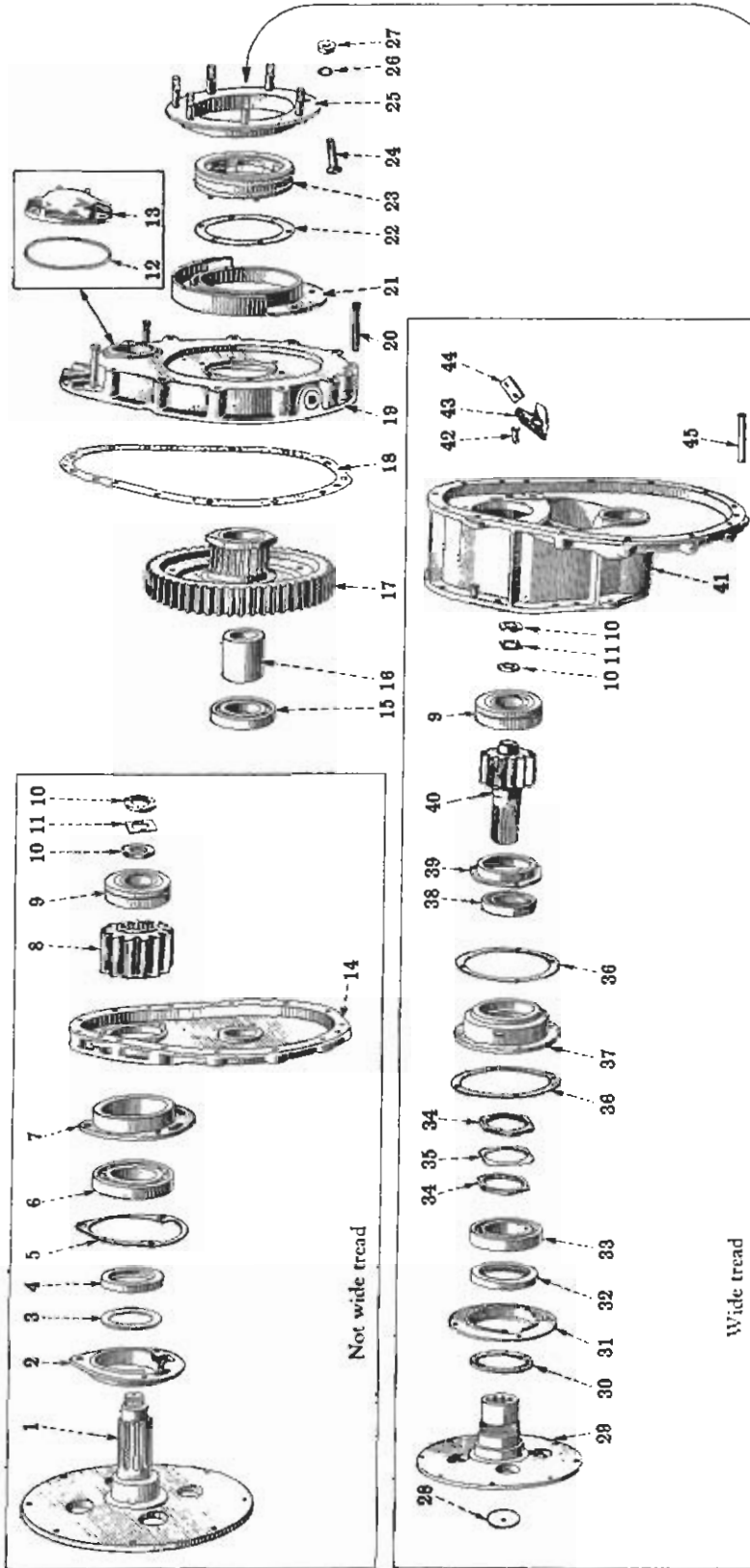

# FINAL DRIVE

SPROCKET DRIVE, SHAFT, PINION AND SPROCKET,  
TRACK FRAME PIVOT SHAFT (T-61 and TD-61)



# FINAL DRIVE

SPROCKET DRIVE, SHAFT, PINION AND SPROCKET,  
TRACK FRAME PIVOT SHAFT (T-61 and TD-61) - Continued

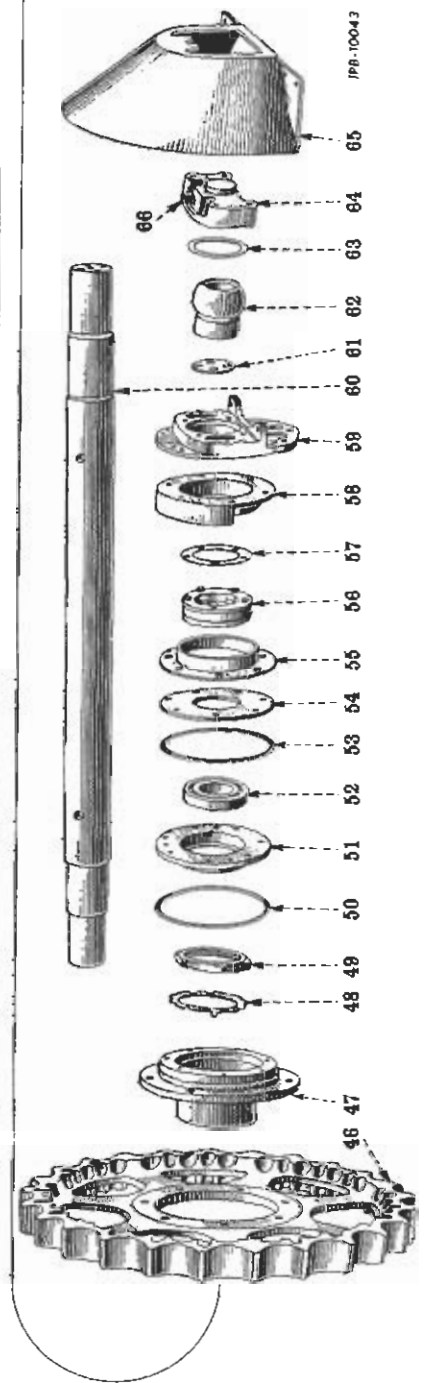

**FINAL DRIVE**

REF. NO.	PART NUMBER	DESCRIPTION
SPROCKET DRIVE, SHAFT, PINION AND SPROCKET, TRACK FRAME PIVOT SHAFT (T-61 and TD-61) - Continued		
1	51 370 DBX	SHAFT w/two NUTS, 51 377 D, sprocket drive pinion (not wide tread) (2)
2	8 498 D	RETAINER, sprocket drive pinion inner bearing (together w/OIL SEAL, 273 565 R91 and WASHER, 260 728 R1) (not wide tread) (will work for 84 980 DXA) (2) 3/8 x 1-1/4" hex-hd. cap SCREW (6) 3/8" lock WASHER (6)
3	260 728 R1	WASHER, sprocket drive pinion shaft felt (not wide tread) (2)
4	273 565 R91	OIL SEAL, sprocket drive pinion shaft (not wide tread) (2)
5	53 803 D	GASKET, sprocket drive pinion inner bearing cage (not wide tread) (4)
6	271 774 R91	BEARING, sprocket drive pinion inner ball (not wide tread) (4)
7	271 772 R1	CAGE, sprocket drive pinion inner bearing (not wide tread) (2)
8	271 775 R1	PINION, sprocket drive (12 T) (not wide tread) (2)
9	271 778 R91	BEARING, sprocket drive pinion outer (2)
10	51 377 D	NUT, sprocket drive pinion and bearing retainer (4)
11	51 378 D	LOCK, sprocket drive pinion and bearing retainer nut (2)
12	271 779 R1	RING, sprocket drive pinion outer bearing cap sealing (2)
13	8 132 DA	CAP, sprocket drive pinion outer bearing (2) 3/8 x 1" hex-hd. cap SCREW (6) 3/8" lock WASHER (6)
14	8 502 DDX 18 524 R1	HOUSING w/pipe PLUG, 18 524 R1, sprocket drive gear inner (not wide tread) (2) PLUG, 1-1/4" sq-socket steel pipe (2) 1/2 x 1-1/4" hex-hd. cap SCREW (4) 1/2 x 1-3/8" hex-hd. cap SCREW (2) 1/2 x 1-5/8" hex-hd. cap SCREW (4) 1/2" lock WASHER (10)
15	271 780 R91	BEARING, sprocket drive gear cylindrical roller inner (2)
16	8 129 DA	SPACER, sprocket drive gear bearing (2)
17	271 781 R91	GEAR, sprocket drive and carrier (51 T w/NUT, 43 819 DA) (2)
18	53 812 D	GASKET, sprocket drive gear housing (2)
19	8 501 DDX 271 848 R1	HOUSING w/pipe PLUG, 271 848 R1, sprocket drive gear outer (LH and RH) (2) 1/2NF NUT (wide tread) (10) PLUG, 1" sq-socket steel pipe (2) 1/2NF x 1-3/8" hex-hd. cap SCREW (wide tread) (6) 1/2 x 2-3/4" hex-hd. cap SCREW (not wide tread) (6) 1/2 x 3-1/2" hex-hd. cap SCREW (16) 1/2NF x 3-1/2" hex-hd. cap SCREW (wide tread) (4) 1/2 x 5" hex-hd. cap SCREW (not wide tread) (4) 1/2" lock WASHER (22) 1/2" external-tooth lock WASHER (4)
20	53 804 D	PIN, sprocket drive gear outer housing to main frame dowel (not wide tread) (4)

**FINAL DRIVE**

REF. NO.	PART NUMBER	DESCRIPTION
SPROCKET DRIVE, SHAFT, PINION AND SPROCKET, TRACK FRAME PIVOT SHAFT (T-61 and TD-61) - Continued		
21	53 555 D	GUARD w/inner and outer dirt DEFLECTORS, sprocket drive oil seal (2) 5/16NF x 1/2" hex-hd. cap SCREW (12) 3/16" lock WASHER (12)
22	45 124 DA	GASKET, sprocket drive oil seal (2)
23	53 535 D	OIL SEAL, sprocket drive (2)
24	46 758 DA	BOLT, sprocket carrier (14)
25	51 373 D	DEFLECTOR, sprocket drive oil seal dirt (2)
26		WASHER, 9/16" sprocket carrier bolt lock (Shakeproof 1126) (14)
27	32 888 D	NUT, sprocket carrier bolt (14)
28	172 599	PLUG, sprocket drive pinion shaft expansion (wide tread) (2)
29	51 365 DAXA	SHAFT w/expansion PLUG, 172 599 and two NUTS, 55 782 D, sprocket drive pinion (wide tread) (2)
30	53 808 D	WASHER, sprocket drive pinion shaft felt (wide tread) (2) (TD-61 38951 to 41321)
31	8 496 D	RETAINER, steering clutch support bearing (together with OIL SEAL, 302 912 R91 will work for 8 496 DX) (wide tread) (2) 3/8 x 1-3/8" hex-hd. cap SCREW (8) 3/8" lock WASHER (8)
32	302 912 R91	OIL SEAL, sprocket drive pinion shaft (wide tread) (2)
33	ST 311	BEARING, steering clutch support ball (IH - PC-275) (2)
34	55 782 D	NUT, steering clutch support bearing (wide tread) (4)
35	55 783 D	LOCK, steering clutch support bearing nut (wide tread) (2)
36	53 805 D	GASKET, steering clutch support bearing cage (wide tread) (2)
36	53 805 D	GASKET, steering clutch support bearing retainer (wide tread) (2)
37	8 504 D	CAGE, LH steering clutch support bearing (wide tread)
37	8 521 D	CAGE, RH steering clutch support bearing (wide tread)
38	271 774 R91	BEARING, sprocket drive pinion cylindrical roller inner (2)
39	271 773 R1	CAGE, sprocket drive pinion inner bearing (wide tread) (2) 3/8 x 1-1/8" hex-hd. cap SCREW (6) 3/8" lock WASHER (6)
40	271 776 R1	PINION, sprocket drive (12 T) (wide tread) (2)
41	8 503 DCX 18 524 R1	CARRIER w/one PLUG, 18 524 R1 and one GASKET, 272 925 R1, sprocket drive (wide tread) (2) PLUG, 1-1/4" sq-socket steel (2) 1/2 x 1-3/8" hex-hd. cap SCREW (20) 1/2" lock WASHER (20)
42	22 977 DA	PIN, sprocket drive carrier to main frame upper dowel (not wide tread) (4)
42	22 977 DA	PIN, sprocket drive gear outer housing to carrier upper dowel (wide tread) (4)



## FINAL DRIVE

REF. NO.	PART NUMBER	DESCRIPTION
SPROCKET DRIVE, SHAFT, PINION AND SPROCKET, TRACK FRAME PIVOT SHAFT (T-61 and TD-61) - Continued		
43	8 497 D	TROUGH, LH steering clutch support bearing oil (together w/LOCK, 64 976 D will work for 8 497 DX) (wide tread) 3/8 x 1" hex-hd. cap SCREW (2)
43	8 522 D	TROUGH, RH steering clutch support bearing oil (together with LOCK, 64 976 D will work for 8 522 DX) (wide tread) 3/8 x 1" hex-hd. cap SCREW (2)
44	64 976 D	LOCK, steering clutch support bearing oil trough cap screw (2)
45	53 804 D	PIN, sprocket drive gear outer housing to carrier lower dowel (wide tread) (2)
46	8 448 DA	SPROCKET (25 T) (not cutaway) (2)
46	8 774 D	SPROCKET, cutaway (25 T) (2)
47	51 369 DA	CARRIER, sprocket (2)
48	43 813 D	LOCK, sprocket drive gear carrier nut (2)
49	43 819 DA	NUT, sprocket drive gear carrier (2)
50	264 258 R1	RING, sprocket drive gear outer bearing cage outer packing (2)
51	264 256 R3	CAGE, sprocket drive gear outer bearing (2)
52	ST 227	BEARING, sprocket drive gear outer ball (2)
53	252 536 R1	RING, sprocket drive gear outer bearing cage inner packing (will work for 264 257 R1) (2)
54	54 511 D	RETAINER, sprocket drive gear outer bearing (2)
55	53 529 D	DEFLECTOR, track frame oil seal dirt (2)
264 259 R1		BOLT, sprocket drive gear outer bearing retainer (14) 7/16" external-tooth lock WASHER (14)
56	53 532 D	OIL SEAL, track frame pivot (2)
57	45 125 DA	GASKET, track frame pivot oil seal (2)
58	53 554 D	GUARD w/inner and outer dirt DEFLECTORS, track frame pivot oil seal (2) 5/16 x 1/2" hex-hd. cap SCREW (12) 5/16" lock WASHER (12)
59	265 959 R1	BRACKET, track frame pivot (2)
265 960 R1		BOLT, track frame pivot bracket top (4)
25 079 D		NUT, track frame pivot bracket top bolt (4)
60	260 890 R2	SHAFT, track frame pivot (not wide tread)
60	260 891 R1	SHAFT, track frame pivot (wide tread)
61	261 287 R1	SHIM, track frame pivot bearing (heavy) (12)
61	261 288 R1	SHIM, track frame pivot bearing (light) (8)
62	260 889 R1	BEARING, track frame pivot (2) 9/16NF x 1-5/8" hex-hd. cap SCREW (4) 9/16" lock WASHER (4)
63	43 846 D	GASKET, track frame pivot bracket cap (2)
104 940		CORK, 1/2 x 11/16" dia. x 7/8" long (xx quality, size 5) (8) 1/2" lock WASHER (8)
64	6 154 DB	CAP, track frame pivot bracket (2) 1/2 x 1-1/4" hex-hd. cap SCREW (8)



## FINAL DRIVE

REF. NO.	PART NUMBER	DESCRIPTION
SPROCKET DRIVE, SHAFT, PINION AND SPROCKET, TRACK FRAME PIVOT SHAFT (T-61 and TD-61) - Continued		
65	53 536 DAX	SHIELD w/SUPPORT and SPACER, sprocket (2) 1/2" NUT (not extended track frame) (4) 3/8 x 2-1/4" hex-hd. cap SCREW (4) 1/2NF x 1" hex-hd. cap SCREW (4) 1/2 x 1-1/2" hex-hd. cap SCREW (not extended track frame) (4) 3/8" lock WASHER (4) 1/2" lock WASHER (8)
66	271 416	FITTING, track frame pivot lubrication (optional with 271 284) (2)
66	271 284	FITTING, track frame pivot lubrication (optional with 271 416) (2)
	57 525 D	ATTACHMENT, cutaway sprocket (consists of two SPROCKETS, 8 774 D and two LOCK-WIRES, 263 945 R1) (See NOTE)
	265 961 R1	BOLT, track frame pivot bracket side (6)
	272 925 R1	GASKET, sprocket drive oil filler plug (2)
	32 454 D	NUT, track frame pivot bracket side bolt (6)
	43 841 D	SCREW, track frame pivot set (2) 5/8" jam NUT (2)
	263 945 R1	WIRE, track master link pin lock (2)

NOTE - Factory Application - Order on  
Machine Order Form.  
Field Application - Order through  
Regular Service Parts Channels.