

STEERING CLUTCHES

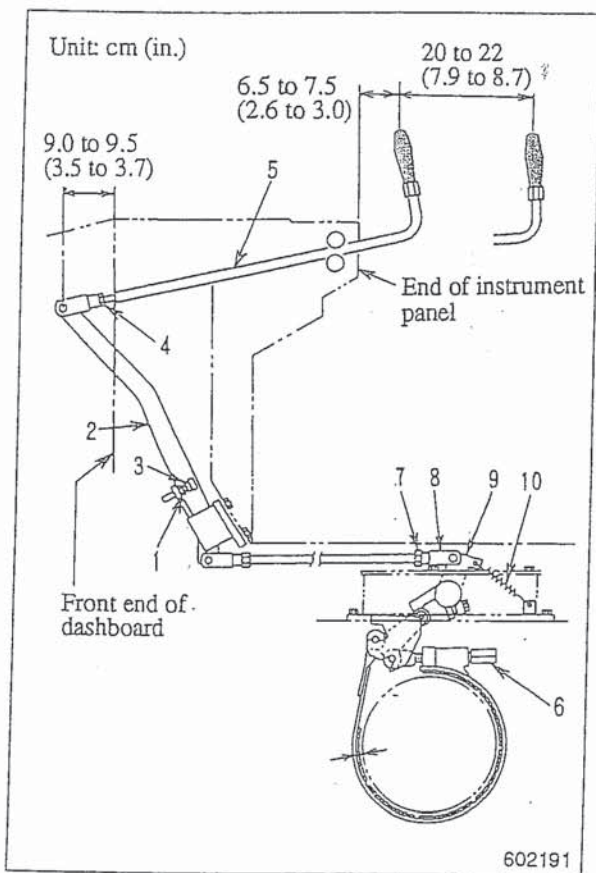

NOTE

The steering clutches and brakes are interlocked with each other. This means that they must be adjusted at one time. Make adjustment (A) thru (D) in that order.

(A) Adjusting the released position of steering clutch levers

1. Loosen lock nut 1.
2. Set lever 2 by turning stopper bolt 3 so that it is 9.0 to 9.5 cm (3.5 to 3.7 in.) from the front end of dashboard. (Equalize the right-hand and left-hand lever positions.)
3. Loosen lock nut 4.
4. Set the knob of steering clutch lever 5 by turning the lever so that it is 6.5 to 7.5 cm (2.6 to 3.0 in.) from the end of instrument panel.

(B) Adjusting the clearance between brake band and outer drum

1. Screw adjusting nut 6 all the way.
2. Back off the nut 2-2/3 rotations.

(C) Adjusting the stroke of steering clutch levers

1. Loosen lock nut 7.
2. Set the stroke by means of clevis 8 so that is 20 to 22 cm (7.9 to 8.7 in.) from release position to fully pulled position.

NOTE

When making a connection to lever 9, lightly push lever 9 forward until it encounters a resistance, with return spring 10 unhitched.

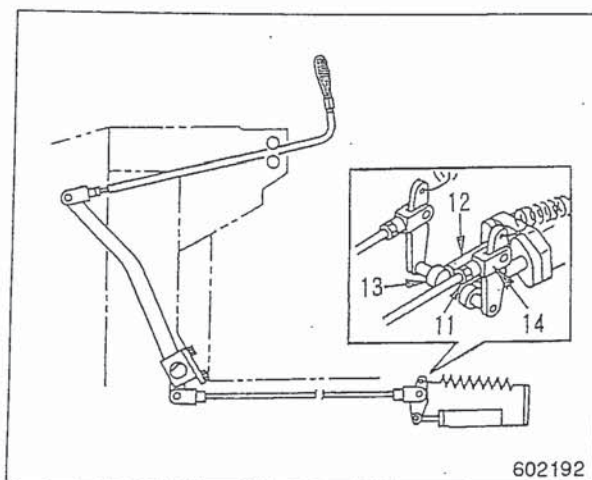

(D) Connecting steering lever to steering valve

1. Loosen lock nut 11.
2. Bring roller 13 into contact with the end of plunger (piston) 12 of the steering valve by means of clevis 14.

NOTE

Do not push in the plunger.

BRAKE PEDAL

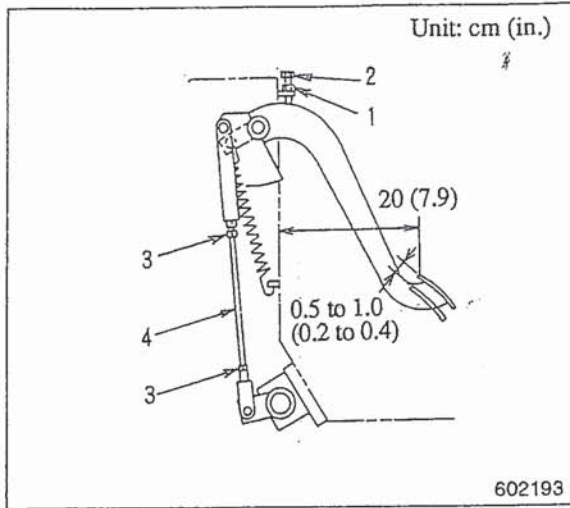

NOTE

There is no need of adjusting the brake pedal stroke after the steering clutch has been adjusted properly. To be adjust on the pedal is its free play.

1. Loosen lock nut 1.
2. Set the released position of the pedal by turning stopper bolt 2 so that it is 20 cm (7.9 in.) from the dashboard wall.
3. Loosen lock nut 3.
4. Set the free play of the pedal by turning rod 4 so that it is 0.5 to 1.0 cm (0.2 to 0.4 in.).

NOTE

Make sure that the right and left brakes are applied simultaneously.

CLUTCH PEDAL

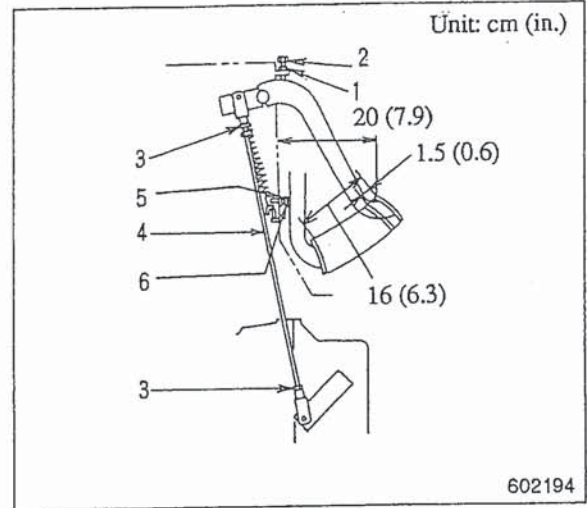

1. Loosen lock nut 1.
2. Set the released position of the pedal by turning stopper bolt 2 so that it is 20 cm (7.9 in.) from the dashboard wall.
3. Loosen lock nut 3.
4. Set the free play of the pedal by turning rod 4 so that it is 1.5 cm (0.6 in.).
5. Loosen lock nut 5.
6. Set the stroke of the pedal by turning stopper bolt 6 so that it is 16 cm (6.3 in.).