

STEERING CLUTCH

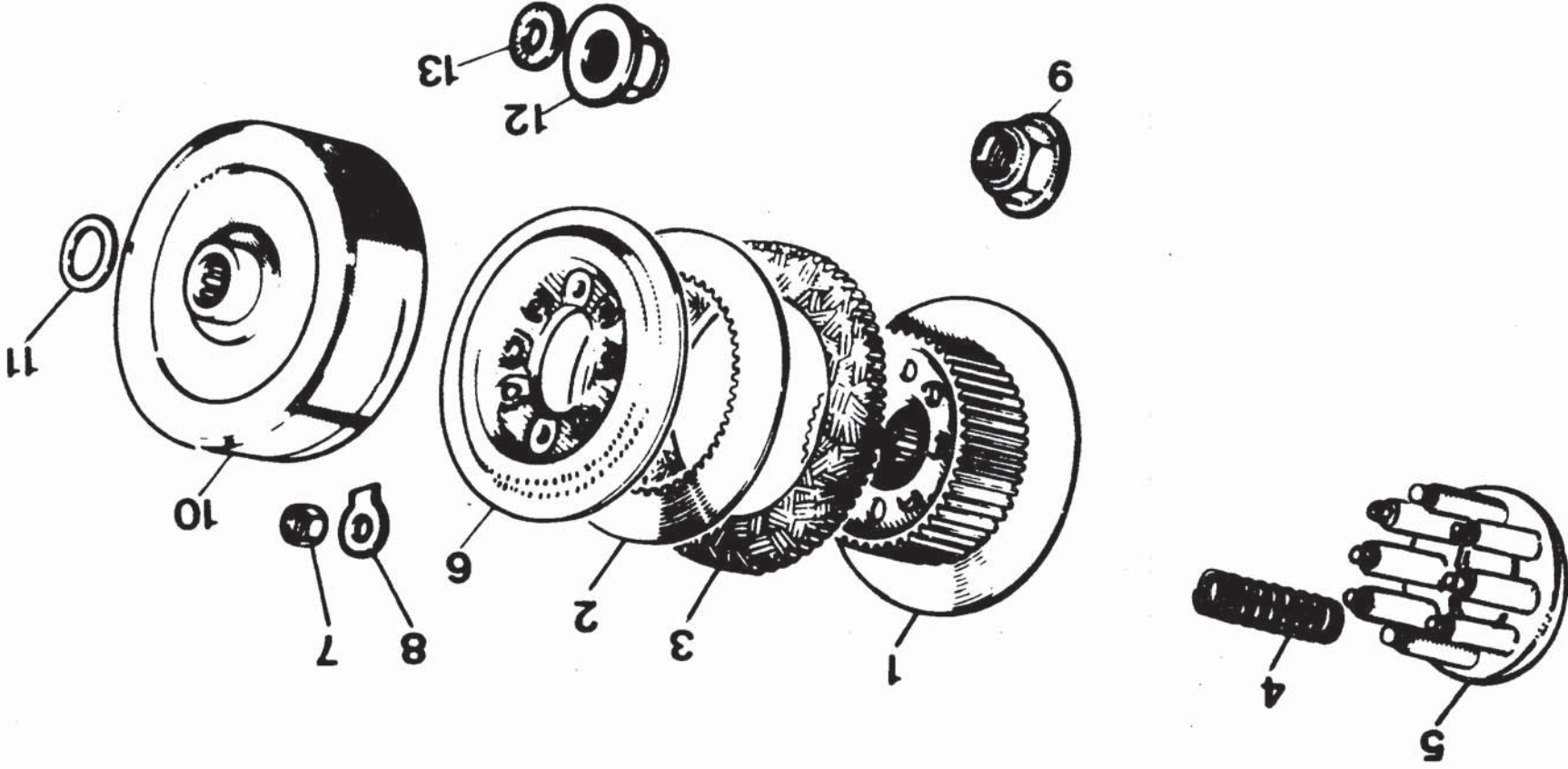

Note	Ref.	MF numbers	Q.ty	Description	Denominazione	Descripcion	Désignation	Benennung
		1492 712 M91	2	Clutch ass'y (c/w ref. 1 to 8)	Frizione di sterzo (compr. rif. da 1 a 8)	Conjunto de embrague de dirección (incl. piezas 1 a 8)	Direction Complete (comp. items de 1 à 8)	Lenkung (einschl. Pos. 1-8)
1		1492 703 M1	2	Drum	Tamburo interno	Tambor	Tambour	Trommel
2		975 743 M1	16	Disc	Disco conduttore	Plato de mando	Disque conducteur	Triebsscheibe
3		975 744 M1	16	Disc	Disco	Plato accionado	Disque conduit	Mitnehmerscheibe
4		975 745 M1	16	Spring	Molla	Resorte	Ressort	Feder
5		1492 704 M91	2	Ring	Anello	Anillo	Anneau	Ring
6		975 749 M2	2	Ring	Anello spingi dischi	Anillo	Anneau	Ring
7		339 252 X1	16	Nut	Dado	Tuerca	Ecrou	Mutter
8		1441 407 X1	16	Washer	Rondella	Arandela	Rondelle	Scheibe
9		975 752 M1	2	Nut	Dado	Tuerca	Ecrou	Mutter
10		1492 701 M1	2	Drum	Tamburo	Tambor	Tambour	Trommel
11		975 751 M1	2	Gasket	Guarnizione	Junta	Joint	Dichtung
12		975 752 M1	2	Nut	Dado	Tuerca	Ecrou	Mutter
13		975 753 M1	2	Gasket	Guarnizione	Junta	Joint	Dichtung

STEERING CLUTCH

Plate 54

CONTROLS STEERING CLUTCH

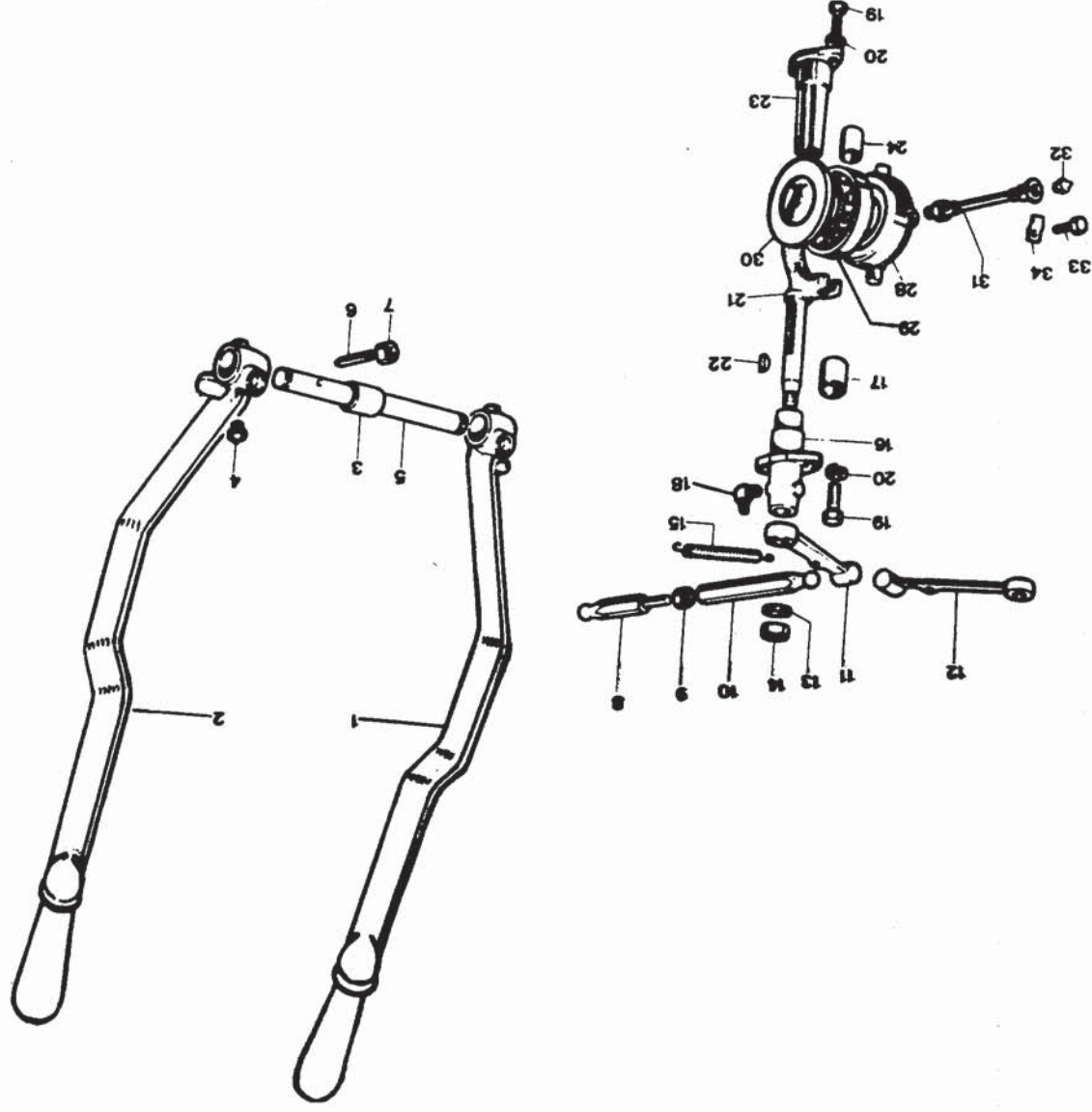

Note	Ref.	MF numbers	Q.ty	Description	Denominazione	Descripcion	Désignation	Benennung
	1	1452 312 M91	1	Lever L.H. (c/w ref. 3-4)	Leva comando sn. (comp. rif. 3-4)	Palanca izquierda (incl. piezas 3-4)	Levier gauche (comp. items 3-4)	Hebel links (einschl. Pos. 3-4)
	2	1452 313 M91	1	Lever R.H. (c/w ref. 3-4)	Leva comando ds. (comp. rif. 3-4)	Palanca derecha (incl. piezas 3-4)	Levier droite (comp. items 3-4)	Hebel rechts (einschl. Pos. 3-4)
	3	975 697 M1	2	Bushing	Boccola	Buje	Bague	Buchse
	4	339 608 X1	2	Grease fitting	Ingrassatore	Lubricador	Graisseur	Schmiernippel
	5	973 383 M1	1	Pin	Perno	Pasador	Axe	Bolzen
		1440 265 X1	1	Screw	Grano	Tornillo	Vis	Schraube
		339 169 X1	1	Nut	Dado	Tuerca	Ecrou	Mutter
	8	973 385 M1	2	Pin	Estremità puntone	Pasador	Rotule	Kugelzapfen
	9	1440 219 X1	2	Nut	Dado	Tuerca	Ecrou	Mutter
	10	973 384 M1	2	Pin	Puntone	Pasador	Tige	Stanger
	11	973 391 M2	1	Lever R.H.	Leva ds.	Palanca derecha	Levier droite	Hebel rechts
	12	973 390 M2	1	Lever L.H.	Leva sn.	Palanca izquierda	Levier gauche	Hebel links
	13	1440 284 X1	2	Washer-flat	Rondella piana	Arandela llana	Rondelle	Scheibe
	14	339 682 X1	2	Nut	Dado fiss. Leve	Tuerca	Ecrou	Mutter
	15	973 157 M1	2	Spring	Molla di richiamo	Resorte	Ressort	Feder
	16	1452 321 M91	2	Bracket (c/w ref. 17)	Supporto sup. (c. rif. 17)	Soporte (incl. pieza 17)	Support (comp. item 17)	Halter (einschl. Pos. 17)
	17	975 703 M1	4	Bushing	Boccola	Buje	Bague	Buchse
	18	1441 983 X1	2	Grease fitting	Ingrassatore	Lubricador	Graisseur	Schmiernippel
	19	339 451 X1	8	Bolt	Vite	Tornillo	Vis	Schraube
	20	1440 314 X1	8	Lockwasher	Rosetta elastica	Arandela de bloqueo	Rondelle grower	Federring
	21	973 386 M3	2	Fork	Forcella	Horquilla	Fourche	Gabel
	22	1440 365 X1	2	Key	Linguetta	Llaveta	Clavette	Scheibenfeder
	23	1452 320 M91	2	Bracket (c/w ref. 24)	Supporto inf. (c. rif. 24)	Soporte (incl. pieza 21)	Support (comp. item 24)	Halter (einschl. Pos. 24)
	24	975 701 M1	2	Bushing	Boccola	Buje	Bague	Buchse
	28	2716 125 M91	2	Collar ass'y (c/w ref. 29-30)	Collare di disinnesto (comp. rif. 29-30)	Manguito de suelta de embrague (incl. piezas 29-30)	Manchon complet (comp. items 29-30)	Ausrück mufte (einschl. Pos. 29-30)
	29	1441 038 X1	2	Bearing	Cuscinetto	Cojlnete	Roulement	Rollenlager
	30	1492 709 M1	2	Screen	Schermo	Reparto	Crible	Steinsort
	31	977 624 M1	2	Hose flex	Tubo flex	Tubo flexible	Tuyou souple	Schlauch
	32	339 608 X1	2	Grease fitting	Ingrassatore	Lubricador	Graisseur	Schmiernippel
	33	339 124 X1	2	Bolt	Vite	Tornillo	Vis	Schraube
	34	973 141 M1	2	Tabwasher	Piastrina	Bloqueo	Plaquette	Sicherungsblech