

**DRIVE TRAIN**

REF. NO.	PART NUMBER	DESCRIPTION	FRANÇAIS	ESPAÑOL	DEUTSCH
----------	-------------	-------------	----------	---------	---------

AXLE SHAFT AND PLANETARY  
(FRONT AND REAR AXLES)

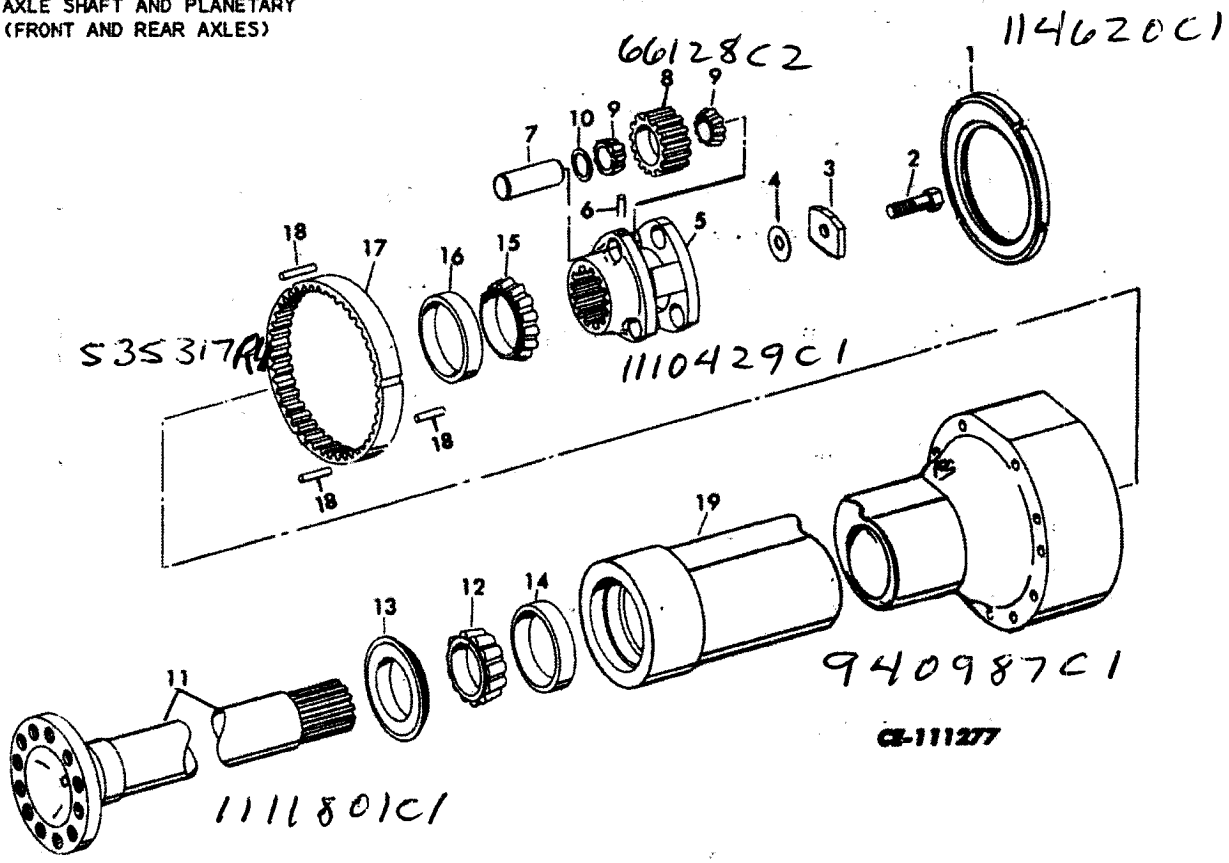

1	114 620 C1	RING, BRAKE OUTER DISC (4)	BAGUE	ANILLO
2	24 873 R1	BOLT, PLANETARY CARRIER RETAINING (USED ON AXLE SHAFT HAVING A 1-1/2" DEEP MOUNTING HOLE) (4)	BOULON	TORNILLO
3	394 748 R1	BAR, PLANETARY CARRIER RETAINING (4)	BARRE	BARRA
4	Z	SHIM (0.002") (X)	CALE	LAMINA DE AJUSTE
4	Z	SHIM (0.007") (X)	CALE	LAMINA DE AJUSTE
4	Z	SHIM (0.012") (X)	CALE	LAMINA DE AJUSTE
4	Z	SHIM (0.0299") (X)	CALE	LAMINA DE AJUSTE

(Z) - ORDER SHIMS PACKAGE,  
65 422 C1. PACKAGE LISTED  
IN THE MISCELLANEOUS SEC-  
TION.

## DRIVE TRAIN

REF. NO.	PART NUMBER	DESCRIPTION	FRANÇAIS	ESPAÑOL	DEUTSCH
AXLE SHAFT AND PLANETARY - CONTINUED (FRONT AND REAR AXLES)					
5	1 110 429 C1	CARRIER, PLANETARY GEAR (RE- PLACES 404 344 R2 AND 114 613 C1) (4)	PORTEUR	PORTADOR	
6	19 723 R1	PIN, (12)	CHEVILLE	PASADOR	
7	399 812 R1	PIN, PLANETARY GEAR (12)	CHEVILLE	PASADOR	
8	66 128 C2	GEAR, PLANETARY	PIGNON	ENGRANAJE	
9	50 212 VA	BEARING, PLANETARY GEAR (24)	ROULEMENT	RODAMIENTO	
10	% %	SHIM (0.042") (X)	CALE	LAMINA DE AJUSTE	
10	% %	SHIM (0.049") (X)	CALE	LAMINA DE AJUSTE	
10	% %	SHIM (0.056") (X)	CALE	LAMINA DE AJUSTE	
11	940 985 C1	SHAFT, AXLE (USED WITH A 1-1/2" MOUNTING BOLT) (4)	ARBRE	EJE	
12	383 970 R91	CONE, BEARING (4)	CONE	CONO	
13	935 491 C1	SEAL, OIL (4)	JOINT D'ETAN- CHEITE	SELLO	
14	572 901 R1	CUP, BEARING (4)	CUVETTE	TAZA	
15	972 465 R91	CONE, BEARING (4)	CONE	CONO	
16	972 466 R1	CUP, BEARING (4)	CUVETTE	TAZA	
17	535 317 R1	GEAR, RING (4)	PIGNON	ENGRANAJE	
18	529 686 R1	PIN, DOWEL (12)	CHEVILLE	PASADOR	
19		HOUSING, AXLE (FRONT AXLE) (REFER TO "FRONT AXLE") (2)	BOITIER	CAJA	
19		HOUSING, AXLE (REAR AXLE) (REFER TO "REAR AXLE") (2)	BOITIER	CAJA	
<u>OPTIONAL PARTS</u>					
2	24 879 R1	BOLT, PLANETARY CARRIER RETAIN- ING (USED ON AXLE SHAFT HAVING A 3" DEEP MOUNTING HOLE) (4)	BOULON	TORNILLO	
(%) - ORDER SHIMS PACKAGE, 65 421 C2. PACKAGE LISTED IN THE MISCELLANEOUS SEC- TION.					

## DRIVE TRAIN

REF. NO.	PART NUMBER	DESCRIPTION	FRANÇAIS	ESPAÑOL	DEUTSCH
AXLE SHAFT AND PLANETARY - CONTINUED (FRONT AND REAR AXLES)					
<u>OPTIONAL PARTS - CONTINUED</u>					
11	940 985 C2	SHAFT, AXLE (USED WITH A 3" MOUNTING BOLT) (4)	ARBRE	EJE	
	OR				
11	1 111 801 C1	SHAFT, AXLE (USED WITH A 3" MOUNTING BOLT) (4)	ARBRE	EJE	
12	984 366 C91	CONE, BEARING (4)	CONE	CONO	
14	984 367 C1	CUP, BEARING (4)	CUVETTE	TAZA	
15	984 360 C91	CONE, BEARING (4)	CONE	CONO	
16	984 361 C1	CUP, BEARING (4)	CUVETTE	TAZA	