

OPERATING MANUAL
FOR
MODEL HE PAYLOADER®

BEGINNING WITH SERIAL NUMBER 55004

FORM HE-3

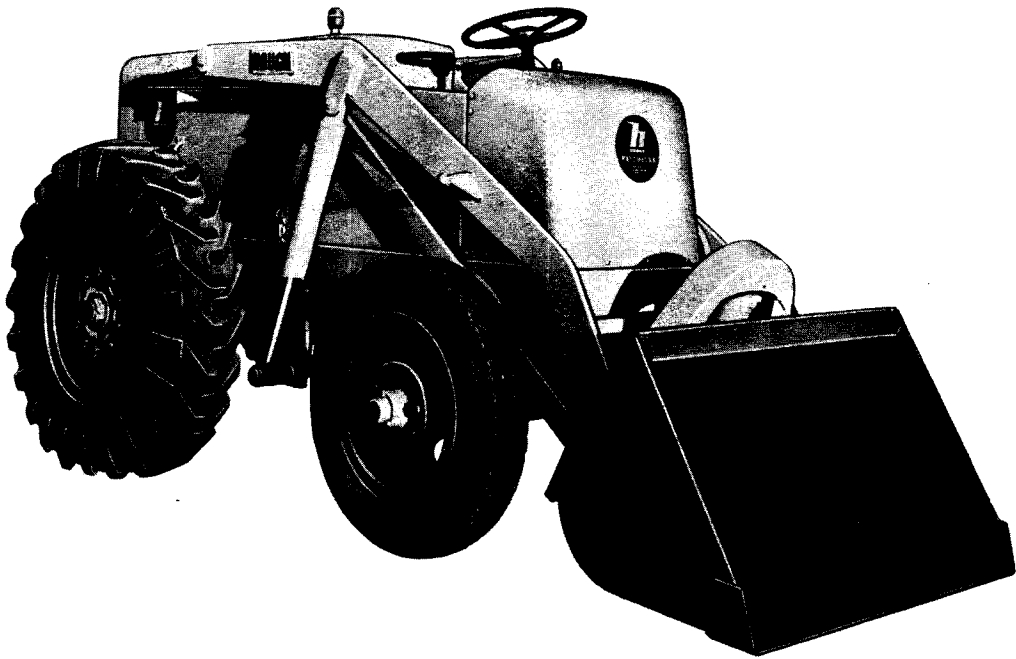

MANUFACTURED BY
THE FRANK G. HOUGH CO.

LIBERTYVILLE, ILLINOIS

LITHO. IN U. S. A.

JUNE 1951

TO THE OWNER

It has been our aim to build the most reliable and serviceable shovel on the market.

Hough shovels have, since 1920, built a reputation for dependable and economical service in the material handling field. This PAYLOADER includes all these features which have made possible long, dependable service, together with the latest engineering knowledge and design.

The purpose of this manual is to explain maintenance requirements and routine adjustments which are necessary for the most efficient operation of your PAYLOADER. To protect your PAYLOADER investment, study this manual before starting or operating your PAYLOADER.

If you should need information not given in this manual, or require the services of a trained mechanic, we urge you to use the extensive facilities offered by THE FRANK G. HOUGH CO. PAYLOADER dealers. Dealers are kept informed on the best methods of servicing and are equipped to provide prompt, dependable, service in the field or in an up-to-date service shop.

Dealers carry ample stocks of THE FRANK G. HOUGH CO. essential PAYLOADER parts.

Listed below you will find the name of THE FRANK G. HOUGH CO. dealer with whom your parts orders should be placed and who should be called upon for any required information concerning proper operating and maintenance procedure.

OUR PAYLOADER DEALER IS:

When ordering parts always give THE FRANK G. HOUGH CO. PAYLOADER dealer both the name and part number of the part required, and also the serial number of the PAYLOADER.

IT IS THE POLICY OF THE FRANK G. HOUGH CO. TO IMPROVE ITS PRODUCTS WHENEVER POSSIBLE AND PRACTICAL TO DO SO. WE RESERVE THE RIGHT TO MAKE CHANGES OR ADD IMPROVEMENTS AT ANY TIME WITHOUT INCURRING ANY OBLIGATION TO MAKE SUCH CHANGES ON MODELS PREVIOUSLY SOLD.

WARRANTY

This Model HE PAYLOADER is warranted free from defects of material or workmanship for a period of six months from date of sale; it is further warranted to be mechanically practical for the purpose advertised by THE FRANK G. HOUGH CO.

Parts claimed to be defective are to be reported to us promptly and returned to us with transportation charges prepaid. If we find the parts defective upon our examination, credit will be issued or the parts replaced.

This warranty will not apply to machines that have been misused, loaded beyond factory rated capacity, neglected, or damaged through accident.

Any expense incurred without authorized consent for repairs or replacements will not be allowed. The use of any but THE FRANK G. HOUGH CO. parts nullifies this warranty.

TABLE OF CONTENTS

NAME	PAGE
TO THE OWNER	Inside Front Cover
SPECIFICATION & SERVICE DATA	2
PREPARATION FOR OPERATION	3
OPERATING THE PAYLOADER	5
Foot Pedals	6
Hand Levers	5
Dash Instruments	6
Starting the Engine	6
Driving the Payloader - working	6-7
Routing Service & Inspection	7
Cold Weather Operation	7-8
Draining the Cooling System	8
MAINTENANCE SECTION	9
Hydraulic System - Care of	9
Hydraulic Diagram	10
Draining the System	9-11
Bleeding the System	11
Packing - Hoist Cylinders	11
Reservoir - Hydraulic Oil	12
Valve	13
Pump	12
Pump Mounting	14
Transmission and Rear Axle	13
Engine	13
Fan Belt	15
Air Cleaner Service	15
Wiring Diagram	16
Drive Shaft	15
Brakes	15-17
Clutch	17-18
Steering Gear	18
Rear Wheel Toe-in	19
Tires-Front & Rear	19
Bucket - Cutting Edge Replacement	20
Lubrication Diagram & Points	21-23

AVOID ACCIDENTS

Most accidents, whether they occur in industry, on the farm, at home or on the highway are caused by failure of some individual to follow simple and fundamental safety rules or precautions. For this reason most accidents can be prevented by recognizing the real cause and doing something about it before the accident occurs.

Regardless of the care used in the design and construction of any type of equipment, there are many conditions that can not be completely safe guarded against without interfering with reasonable accessibility and efficient operation.

A CAREFUL OPERATOR IS THE BEST INSURANCE AGAINST AN ACCIDENT.

THE COMPLETE OBSERVANCE OF ONE SIMPLE RULE WOULD PREVENT MANY THOUSAND SERIOUS INJURIES EACH YEAR. THAT RULE IS:

"Never attempt to clean, oil or adjust a machine while it is in motion!"

"National Safety Council"

SPECIFICATIONS AND SERVICE DATA

ENGINE:

Waukesha	F.C. Industrial
No. of Cylinders	4
Bore	3-1/4"
Stroke	4"
Displacement, cu. in	133
Engine Speed - Governed	2200 R.P.M.

TRANSMISSION:

4 speed forward and reverse transmission.

FINAL DRIVE:

Double reduction final drive.

CLUTCH:

12" spring loaded, foot operated, single disc.

BRAKES:

Hydraulic wheel brakes, internal expanding, 2 shoe type in both rear wheels.

STEERING GEAR:

Heavy duty recirculating ball type steering mechanism.

BATTERY:

Exide sure start #1.

TIRES:

Front 7.00 x 20-8 ply
 Rear 12.00 x 24-6 ply

TIRE PRESSURE:

Front 55 lbs. (air)
 Rear 25 lbs. air and 3/4
 full of calcium chloride solution

PAYLOADER DIMENSIONS: Bucket in Carry Position

Over all Height at Air Cleaner	5'-9"
Over all Width at rear tires	5'-10"
Over all Length	13'-10"
Turning Radius to tip of Bucket.	14'-9"
Ground Clearance.	1'-0"
Wheelbase.	5'-0"
Service Weight - Empty Bucket.	Approx. 7525 lbs.

CAPACITIES:

Cooling System	3-1/2 gallons
Fuel Tank	9 gallons
Crankcase Oil - with oil filter	5 quarts
Transmission Oil - EP 90 Summer and Winter	9 pints
Differential Oil - SAE 140 Summer - SAE 90 Winter.	5 pints
Reduction Gear Oil - SAE 140 Summer - SAE 90 Winter	6 pints each side
Hydraulic System oil - SAE 10 Motor Oil	11 gals. Approx.

PREPARATION OF THE PAYLOADER FOR OPERATION

Before operating this PAYLOADER, even to unload, check the entire unit to make sure nothing has become loose or damaged in transit or storage.

Battery cables have been disconnected at the factory, the cooling system drained and the gasoline shut off cock closed before shipment.

DO NOT ATTEMPT TO START THE ENGINE BEFORE THE FOLLOWING POINTS HAVE BEEN CHECKED OR DAMAGE MAY RESULT.

REFER to the Lubrication Chart, to locate the following points.

1. Check the oil level in the Hydraulic System Reservoir to make sure it is up to the "full" mark on the dip stick. The Engine MUST NOT be started without oil in the Hydraulic System. Use SAE 10 Motor Oil or equal to refill. Drain the hydraulic system after the first 32 to 48 hours of operation and refill with clean oil. Be sure to clean the suction outlet strainer at this time.
2. Check the Oil Level in the engine crankcase by removing the oil dip stick from the engine.
3. Check the Oil Level in the transmission to be sure it is to the height of the oil level plug.
4. Check the Oil Level in the Differential and both Axle Reduction Gear Cases. Differential Oil Level plug is located in the rear of the Housing. Rear Axle Reduction Gear Case Level plugs are located on the inside surfaces of both rear wheel housings.
5. Check oil in the Air Cleaner Cup. Clean and refill daily or oftener as required. This is important.
6. Check the Master Brake Cylinder to make sure it is filled with brake fluid. If not, fill with "Lockheed" Hydraulic Brake Fluid.
7. Be sure all hoses and connections are tight to prevent hydraulic oil from leaking out and to keep air or water from entering the system. Water entering the system will cause pump corrosion at high velocities. Air in the system will cause the oil to foam and the hoist to operate in a slow, jerky manner.
8. Check the Tire Pressures. Be sure they are up to pressures recommended in the Specifications & Service Data Lists.
9. Fill the cooling system with clean soft water, free from alkaline; never at anytime run the engine without the full quantity of water in the radiator. Be sure to add an anti-freeze solution to the cooling system during freezing weather.
10. Be sure to open the fuel line shut off cock. Fill the tank using a gasoline with minimum octane rating of 70-72. Fuel tank is mounted under the Grille and shut off cock is located on the fuel line at the fuel tank.
11. Be sure all drain plugs, drain cocks, filler openings and fuel line connections are tight and do not leak.
12. Connect battery cables and check the dash instruments to be sure they function properly. Check the battery to be sure the plates are covered with water. If not, add distilled water or clean rain water.
13. With the PAYLOADER properly serviced and checked, the engine may be started.

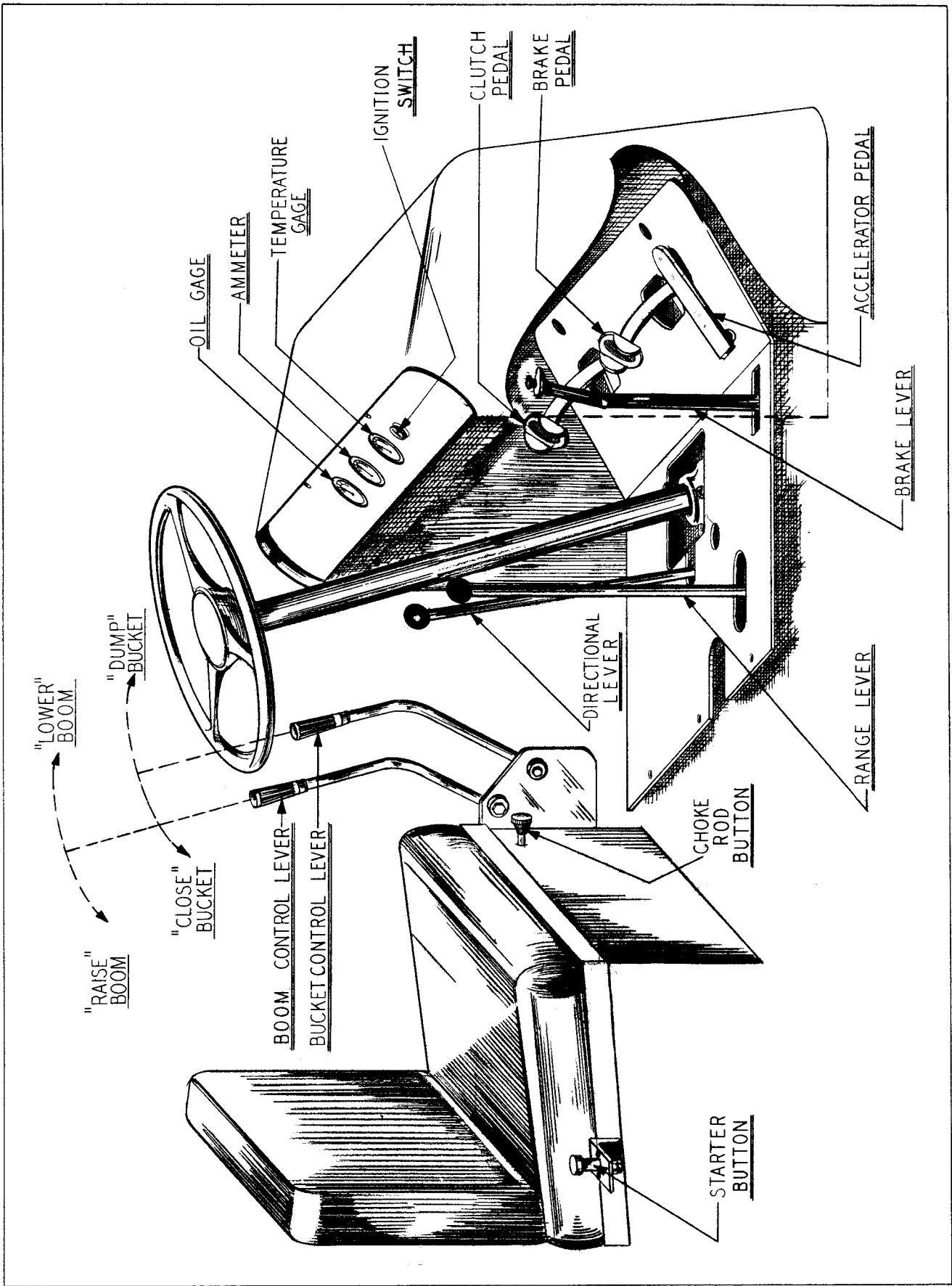

Fig. 1

OPERATING THE PAYLOADER

When learning to use a machine of this type, it is well for the operator to work carefully, taking his time to gradually become accustomed to the machine. Operating speed and skill will be attained easier by slowly acquiring the "feel" of the PAYLOADER. The time used in learning may be well spent in preventing possible accidental damage to the machine or operator and to safe guard other personnel. The main factor in the performance of any machine of this type lies with the operator.

A study of the following pages should be made by the operator before attempting to start the engine. This will acquaint him with the functions of the various controls and their use. Refer to the Operators Control picture to note location of the levers and pedals.

The term "right hand" or "left hand" as used in these pages, are determined by the operators position when sitting in the seat facing the bucket.

HAND LEVERS:

This PAYLOADER is equipped with a four speed forward and four speed reverse Transmission. The speeds and direction are selected by shifting a Range Lever and a Directional Lever.

RANGE LEVER is located on the right side of the floorboard and has five positions. This lever is in neutral when in a vertical centered position. Shift this lever to the left of the neutral and backward

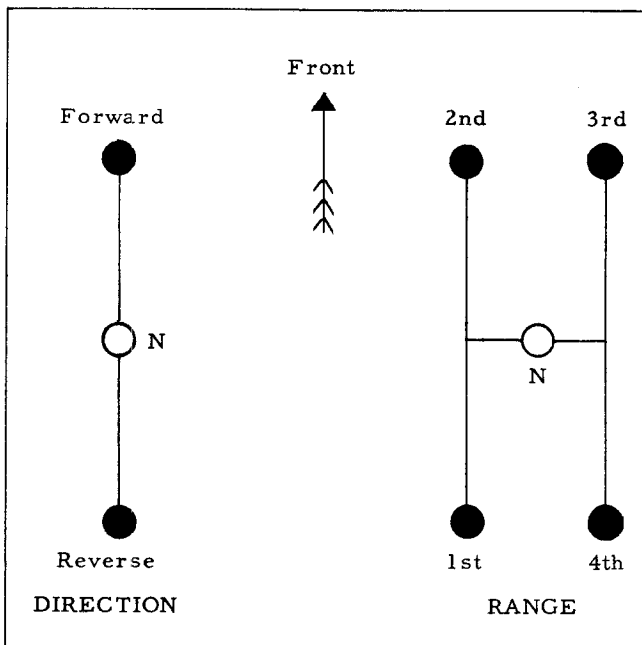

Fig. 2
GEARSHIFT DIAGRAM

for the lowest speed range. Shift it to the right and rear of neutral for the highest speed. One of the low speed ranges is used for working conditions where more power is needed. One of the high speed ranges is used primarily for transporting loads to various locations.

DIRECTIONAL LEVER is located between the steering column and the seat. The PAYLOADER will travel forward when this lever is pushed forward or away from the operator. Pull the lever backward toward the operator to move the PAYLOADER backward or in reverse.

Always depress the clutch when shifting these levers to any of their positions.

VALVE CONTROL LEVERS - These machines have dual valve control levers, located on the left hand side of the seat, and may be operated as soon as the engine is started.

The rear lever controls the "Raising" and "Lowering" of the bucket and the front lever controls the "Dumping" action of the bucket.

The rear lever has three positions which can be felt by the operator as the poppets fall in place when the lever is moved. Placing this lever in the centralized or neutral position will stop the movement of the boom and "hold" the bucket at any height in its arc of travel.

Pull this lever backward, toward the operator and the booms and bucket will "raise" in direct proportion to the engine speed.

Push this lever forward, ahead of neutral to "lower" the boom and bucket.

CAUTION: NEVER REACH BETWEEN THE BOOM AND GUIDE BARS TO OPERATE THESE LEVERS. THE BUCKET MAY BE LOWERED EVEN THOUGH THE ENGINE HAS BEEN SHUT OFF.

The front valve control lever is used to "dump" the bucket. Push this lever forward, away from the operator to "dump" the bucket. Merely release pressure on this lever and it will automatically return to neutral, "stopping" the bucket at any point of its dumping arc. Pull the lever backward to "close" or "retract" the bucket. Merely release the lever to return it to neutral and the bucket will be "held" in the "retracted" position.

PARKING BRAKE HAND LEVER - The parking brake hand lever is located on the right side of the floorboard. Pull the lever backward to apply braking pressure on the drive shaft brake drums. Press the top button and push downward to release braking

pressure on the drive shaft. This lever is used when parking the PAYLOADER on slopes. Do not fail to release this lever before putting the machine in motion.

FOOT PEDALS:

The Clutch pedal is located on the left side of the floorboard. When pushed down the transmission is disengaged from the engine. Always keep the clutch pedal depressed when shifting either the range lever or the directional lever. Do not engage the clutch suddenly, thus allowing the PAYLOADER to jerk with the load.

CAUTION: DO NOT DRIVE THE PAYLOADER WITH THE FOOT RESTING ON THE CLUTCH PEDAL. THIS WILL CAUSE UNDUE WEAR ON THE CLUTCH FACING AND THROW-OUT BEARING.

The Brake pedal is located on the right side at the floorboard and is used to bring the PAYLOADER to a stop. Depress the brake firmly when braking. It is good practice to keep the clutch engaged until the PAYLOADER has been slowed down and nearly brought to a halt by depressing the brake. Then disengage the clutch and stop the motion of the machine completely. This allows the engine compression to assist the brakes and saves wear on the brake linings.

The ACCELERATOR Pedal is mounted on the floorboard to the right of the brake pedal. Applying pressure on this pedal increases the flow of fuel to the cylinders by opening the carburetor intake. This increases the engine speed thereby accelerating the motion of the PAYLOADER. Apply a slight increasing pressure on the accelerator pedal while releasing pressure on the clutch pedal to allow the machine to start evenly, without jerking.

The raising speed of the booms and bucket is also governed by the accelerator.

DASH INSTRUMENTS:

IGNITION SWITCH is on the right side of the dash panel and is the push-pull type. This switch completes the electric circuit to the coil, and to the dash instruments, when in the "on" position.

AMMETER indicates whether the battery is being charged or discharged. The ammeter needle should be in the "Charge" range during operation. If in "Discharge" range continuously, the cause should be investigated to avoid completely discharging the battery.

TEMPERATURE GAUGE registers the temperature of the liquid in the cooling system. Temperature may indicate as high as 190° F. when operating in confined quarters.

OIL PRESSURE GAUGE indicates the pounds pressure of the oil circulating through the engine. If this gauge fails to register, stop the engine immediately and determine the cause.

CHOKER ROD is the left hand button on the seat support and is used to enrich the fuel mixture when starting the engine. Pull out the rod to choke.

STARTER BUTTON is to the right of the seat and when pressed in it completes the electrical circuit between the battery and the starting motor. Release the pressure on this button as soon as the engine starts.

STARTING THE ENGINE:

With the PAYLOADER properly inspected and checked as explained in the preceding pages, the engine may be started. The hydraulic hoists may be operated as soon as the engine is started since the power to operate the hydraulic pump is taken directly from the engine.

Be sure the range lever is in neutral and the valve control levers in "hold" position before starting the engine.

1. To start, the ignition switch must be in the "on" position.
2. Press the starter button. Pull out the choke slightly to start if necessary.
3. Immediately on starting, check the oil gauge on the dash to be sure it is registering.

STOPPING THE ENGINE:

To stop the engine merely turn off the ignition switch. Be sure all levers are in neutral position before leaving the seat. NOTE: The bucket can be lowered even though the engine has been stopped. Never attempt to operate the hand levers by reaching between or under the boom and guide bars.

DRIVING THE PAYLOADER:

Skill in the use of the Shovel is acquired by practice, and by intelligent observation of the operation of the machine. For instance, correct Loading of the bucket can be judged by the feel of the operating lever, the sound of the engine, and the speed of the tractor.

1. When the engine has been running long enough to warm up partially, and oil pressure has been built up as indicated on the dash gauge, the "PAYLOADER" may be put to work.
2. Draw backward on the valve lever controlling the boom to raise the boom and bucket about two or three feet above the ground

3. Depress the clutch and shift the directional lever and the speed range lever into one of their positions depending on direction and speed of travel wanted.
4. Release the pressure on the clutch pedal while increasing pressure on the accelerator pedal and drive to the working area.

LOADING THE BUCKET:

Shift to one of the slow speed ranges for the best average speed when loading the bucket. When stripping, digging a pit or foundation it is better to take a shallow cut and let the forward movement of the machine fill the bucket. Have the bucket fully closed or retracted and hold the cutting edge at digging level. The operator may manipulate the boom control lever slightly, raising or lowering the bucket to hold a good grade as the machine travels forward.

When the bucket is full or the end of the cut is reached, pull backward on the boom lever to raise the bucket out of the cut. As the bucket raises it will crowd forward into the face of the cut, exclusive of the forward travel of the machine. This is especially noticeable when cutting into a bank or stock pile. The forward movement of the tractor and the bucket tip-back feature will give a scooping action similar to a "dipper stick" shovel as the bucket raises out of the stock pile or face of the bank being cut. As the bucket raises it tips back to hold a full load with minimum spillage.

TRANSPORTING LOADS:

When transporting loads the travel speed of the machine will depend on the length of haul and the kind of surface over which the machine must travel. Rough terrain calls for slow speed.

When the bucket is full, raise the boom to carry the bucket about four (4) feet above the ground. Never transport loads with the bucket fully raised. The nearer the ground the bucket is held the better the stability, especially on side slopes or when turning the machine. Shift the gears into position for speed and direction of travel desired and drive the machine to the dumping location.

DUMPING THE BUCKET:

When dumping into a truck or bin, raise the bucket so it clears the top edge by about three (3) feet. Move the machine up so the bucket is inside the dumping area. With the boom lever in the hold or neutral position, push forward slowly on the bucket control lever, thus causing the bucket to tip forward and spill its load. The load may be dumped entirely or part at a time by manipulating the bucket lever. Dumping the load slowly will ease the shock of suddenly added weight to the truck body. Releasing pressure on the bucket control lever will allow it to return to neutral holding the bucket in dumped posi-

tion. Pull backward on the bucket control lever to return the bucket to closed position before backing the machine away from the dumping area. Back the machine well away from the truck or bin and lower the bucket to carry position (about four (4) feet above the ground) before returning the machine for another load.

BACKFILLING AND BULLDOZING:

The bucket can be removed and replaced with a backfiller blade for bulldozing operations. Use the backfiller blade to spread material, strip, level, or to backfill ditches and foundations. Again, one of the slow speed ranges is best when working with a backfiller blade since backfilling requires more power and slow speed.

The backfiller blade pivots at the same points as on the bucket, and may be dumped and retracted similarly. This feature will be helpful when working wet clay or other sticky material.

ROUTINE SERVICE:

The operator's job does not consist of merely working the "PAYLOADER". The mechanical and operating condition as well as the general appearance and maintenance of the machine is also a part of his responsibility. It is to the operator's advantage to become familiar with the functions of each working part and a study of the information and suggestions as set forth in this manual will help him to do so.

The operating life of the "PAYLOADER" may be considerably extended if the machine is properly serviced at regular intervals. Often major repairs or shut downs are avoided if the machine is inspected regularly and minor trouble corrected at this time.

Refer to the LUBRICATION CHART for major points requiring periodic service and inspection.

COLD WEATHER OPERATION:

When operating the "PAYLOADER" in temperature of 32° F. (0° C.) or lower, there is danger of the water freezing in the cooling system and an anti-freeze solution must be used. To avoid freeze ups in the cooling system, use a solution of denatured alcohol and water or ethylene glycol as they will not damage the radiator, pump or other parts thru corrosion.

Do not use a calcium chloride solution or any alkaline solution as they are injurious to metal.

If alcohol is used as an anti-freeze solution, use a hydrometer daily to check the strength of the solution as alcohol tends to boil away at average temperature. Add a small amount of alcohol daily to replace that lost by evaporation.

There are several standard reliable anti-freeze

solutions on the market which may be used in the cooling system, They should be added to the radiator according to the manufacturers instructions found on the container. See Specification Data list for cooling system capacities.

IMPORTANT: Before filling the radiator with water in freezing temperatures, cover the entire radiator, start the engine and immediately put in the water. This prevents the water freezing during the warm up period. Remove the covering when the engine has warmed up.

If no anti-freeze solution is used in freezing temperatures, the entire cooling system must be drained every time the engine is stopped for prolonged periods.

Never pour cold water in a hot engine as the sudden contraction may result in a cracked engine block.

DRAINING THE COOLING SYSTEM:

To drain the cooling system first remove the radiator cap, then open the radiator drain cock and the engine block drain cock. The radiator cap is a pressure type and must be removed to permit draining.

The cooling system should be flushed out seasonally, before adding anti-freeze solution and when draining out the anti-freeze solution, to avoid accumulations of dirt and gum in the radiator tubes.

MAINTENANCE SECTION

Regardless of the care used in the design and construction of any type of equipment, there are many conditions that cannot be completely safeguarded against without interfering with reasonable accessibility and efficient operation. The complete observance of one simple rule would prevent serious injuries each year. That rule is --

"NEVER ATTEMPT TO CLEAN: OIL OR ADJUST A MACHINE WHILE IT IS IN MOTION."

-- National Safety Council --

NEVER WORK UNDER THE BOOMS OR BUCKET UNLESS THEY ARE BLOCKED AND CANNOT BE LOWERED ACCIDENTLY.

The following paragraphs are not intended to cover all repair problems that may confront the operator. They are merely intended to assist the mechanic or operator in routine adjustments and maintenance which may be done in the field for the most efficient operation of the machine.

For major repairs, refer your problems to THE FRANK G. HOUGH CO. DISTRIBUTOR to obtain the services of a trained mechanic.

HYDRAULIC SYSTEM - CARE OF:

The hydraulic system consists of an oil reservoir, a pump, a control valve, two boom hoists, one bucket control cylinder and the connecting hoses and fittings.

The pump draws oil from the reservoir thru the suction line and forces it under pressure into the control valve which regulates the flow of oil to the hoists. The valve is manually controlled by the Operator by means of the valve control lever.

The pump is protected against severe overloads by a pressure relief built into the valve.

1. Check the oil level in the reservoir daily. The bucket should be fully retracted and resting on the ground when checking the oil level. Low oil level will cause cavitation and the unit will operate in a slow, jerky manner and the pump will howl.
2. Check the hoses and connections daily to prevent oil from leaking out and air or water from being sucked into the system.

NOTE: Air may be sucked into the system thru a faulty connection although oil will not leak out. Air in the system will cause the oil to foam and interfere with the smooth action of the boom and bucket. The unit will be noisy and the pump will howl.

3. Drain the oil from the system, clean the suction line strainer in the reservoir and refill the system with a good grade of SAE-10 Motor Oil after the first 32 to 48 hours of actual operation. Thereafter, drain the system and clean the suction line strainer monthly, or oftener if working conditions are unusually dirty and dusty.

In hot weather or where the "PAYLOADER" will operate in temperatures above 90° F., it may improve the operation by refilling the system with a good, clean, grade of SAE-20 Motor Oil. Do not use SAE-20 oil in moderate temperatures.

4. Drain the hydraulic system only after the "PAYLOADER" has been operated for a time and while the oil is still warm. Warm oil will drain more freely and carry more impurities out with it.
5. The very small amounts of water in the system thru condensation will evaporate when the oil becomes warm by operation. However, water sucked into the system must be removed by draining the system, or it will cause corrosion and erosion of the pump and hoist plungers.
6. A dirty suction line strainer will retard the flow of oil, causing cavitation, and the pump will be noisy. It will prevent the "PAYLOADER" from operating smoothly, similar to air in the system.
7. Use a good clean grade of white lead, Aviation Permatex or insoluble plastic lead seal, on the male threads only, when reconnecting a fitting or joint. Do not allow the thread sealer to enter the valve or pump.
8. The system must be "bled" or purged of air after any work has been done on it, or after it has been drained.

DRAINING THE HYDRAULIC SYSTEM:

NOTE: DRAIN IMMEDIATELY AFTER THE "PAYLOADER" HAS BEEN OPERATED FOR A TIME AND WHILE THE OIL IS STILL WARM; WARM OIL WILL CARRY MORE DIRT AND SLUDGE WITH IT.

To drain the entire hydraulic system proceed as outlined.

1. Raise the boom to full height with the bucket in dumped position. Block or chain the booms up in the raised position so they cannot fall when the oil drains from the hoist cylinders. Then shut off the engine.

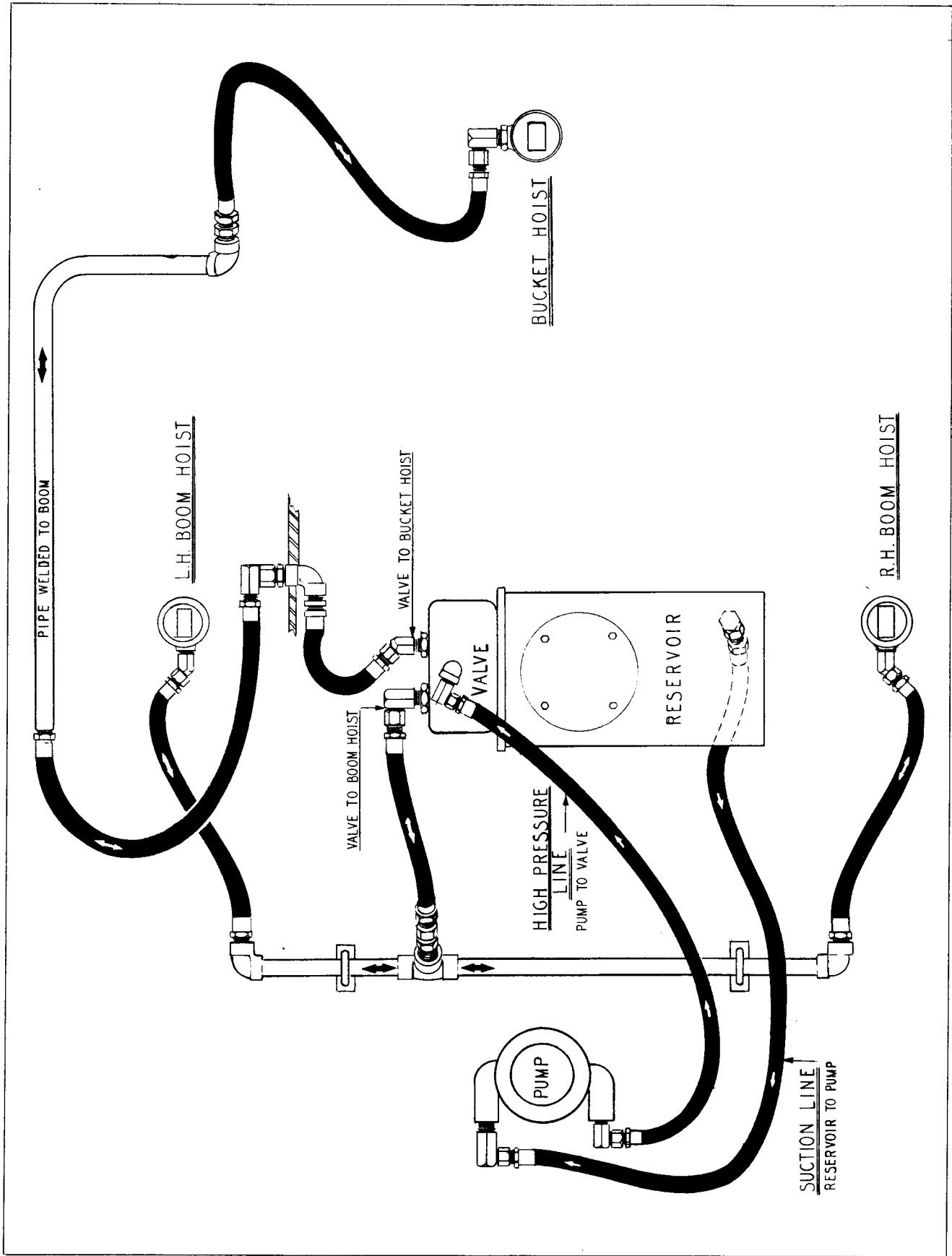

Fig. 3
HYDRAULIC DIAGRAM

2. Place a 15 gallon container near the reservoir drain plug, procure a funnel and hose to direct the oil from the reservoir into the container - then remove the drain plug.
The drain plug is a magnetic type and must be thoroughly cleaned before replacing.
3. After the reservoir has drained, break the hose connections at the pump to drain the pump and pump hoses.
4. Break the boom hoist hoses at the frame to drain the boom hoist cylinders.
5. Break the boom pipe hose connection at the frame to drain the bucket control cylinder and the boom pipe.
6. Remove the reservoir clean-out cover: reach into the reservoir to remove the suction line strainer. The strainer must be washed thoroughly in clean gasoline to remove all particles of dirt and lint.
7. Remove the cap from the reservoir breather and wash it in gasoline to clean the air passages.
8. Flush and clean all sludge and dirt from the bottom of the reservoir being careful not to force sludge or dirt into the valve. If the reservoir is very dirty, or if dirt is forced into the valve, it must be removed and the valve washed out in clean gasoline.
9. After the system has been drained and cleaned, replace the drain plug, the strainer and the valve and remake all broken connections. Be sure the connection are tight and will not leak oil or suck air. See "CARE OF THE HYDRAULIC SYSTEM".
10. Refill the system to the top of the reservoir with a good grade of SAE 10 Motor Oil.
11. Start the engine, allow it to operate at idle speed until it partially warms up and giving it time to pump oil into the cylinders. Operate the bucket cylinder thru its dumping cycle several times. Remove the blocks or chains holding the boom in raised position. Do not stand or work under the bucket when the blocking is removed. Operate the boom by raising and lowering it several times, then allow the bucket to rest, fully closed, on the ground and shut off the engine.
12. Inspect all connections and the drain plug for leaks at this time.
13. After all work has been completed, refill the reservoir to the proper level. This is necessary as oil will have been pumped into the hoist cylinders and hoses thereby reducing the oil level in the reservoir.
14. Replace the clean out cover and the breather cap. Be sure the cover gasket is in place and the breather is clean.
15. After the system has been drained and refilled, or any work done on it, the system must be "bled" or purged of air.

BLEEDING THE SYSTEM:

1. Start the engine, raise the bucket to nearly full height, slowly open the bleeder screws in the upper end of the boom hoist cylinders. Operate the bucket thru its dumping cycle slowly several times.
2. As soon as air bubbles cease to escape from around the bleeder screws, tighten the screws securely. Clean the hoist cylinders of oil that escaped thru the bleeder screws.

HYDRAULIC HOIST CYLINDERS:

The Hydraulic Cylinders are so constructed that no adjustments are necessary other than to tighten the packing if oil escapes excessively.

IMPORTANT: ADJUST THE PACKING, BY TURNING THE PACKING NUT, SO A SLIGHT FILM OF OIL ADHERES TO THE PLUNGER, AT ALL TIMES, AS IT EMERGES FROM THE CYLINDER.

This compensates for packing wear and allows the wiper seal to remove dirt and other foreign matter from the plunger as it is drawn into the cylinder.

The hydraulic hoist packing is the chevron type and is made up in sets of special rings. When the packing and wiper seals become worn, as evidenced by oil escaping excessively, they must be replaced.

BOOM HOIST PACKING:

1. To replace the boom hoist cylinder packing have the bucket resting on the ground, place the valve levers in neutral position to close off the reservoir oil from the hoist and shut off the engine.
2. Disconnect the hose to the hoist cylinder and cork the opening on the valve side. The oil in the hoist will drain out when the line is disconnected from the hoist.
3. Remove the hoist upper pivot pin to free the cylinder from the boom bar. Support the cylinder to hold it from falling when the pivot pin has been removed.
4. Attach a chain hoist or crane to the boom to raise it slightly to allow the cylinder to swing downward and rest on the front axle bar.
5. Unscrew the packing nut out of the cylinder.

Using an ice pick or similar tool, remove the worn packing, paying attention to the way the old packing rings were arranged.

Clean out the packing recess thoroughly before inserting the new rings.

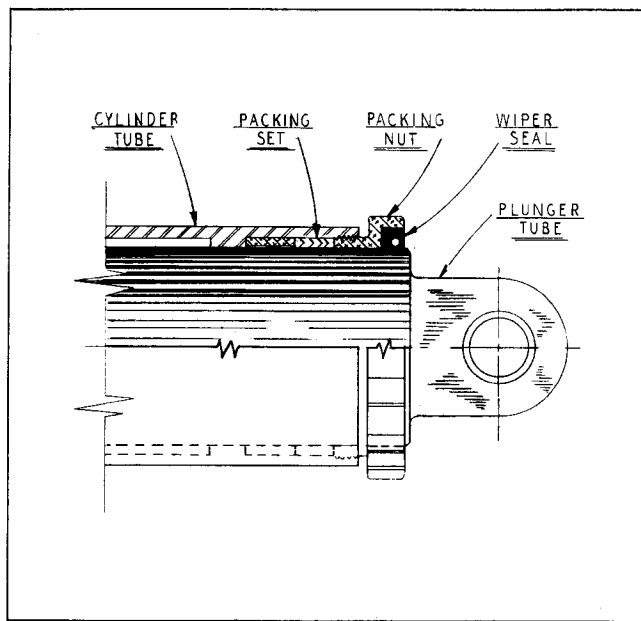

Fig. 4

HOIST CYLINDER PACKING DETAILS

6. Insert the new packing by first placing one of the flat sided rings in the bottom of the recess, flat side down. Tamp it firmly but gently in place with a blunt instrument. Be careful not to damage the rings while placing them in the recess. Be careful not to scratch or mar the plunger rod when tamping in the rings. Insert the "V" rings on the first ring, then add a flat ring on top.

NOTE: If any of the rings are damaged when being placed in the recess, discard them for another. A damaged ring will not seat properly and will permit oil to escape.

If the new packing is coated with wax it must be removed by light scraping and then powdered with graphite. If a ring is damaged by scraping it must be discarded. Leather rings may be soaked in hot oil to soften them.

7. When the packing has been assembled properly and the nut pulled down snugly, a light film of oil should adhere to the plunger as it is drawn from the cylinder at all times. Adjust the packing nut from time to time to maintain this condition.
8. Raise the cylinder and lower the boom to reinsert the upper pivot pin to connect the hoist to the boom. Reconnect the hose to the cylinder being sure to remove the plug placed in the hose to hold the oil. Make the connection tight.

9. Start the engine, raise and lower the boom several times, then shut off the engine with the bucket resting on the ground.

10. Inspect the connections for leaks. Add oil to the reservoir to bring the oil level up to proper height to replace the oil lost from the cylinder. Then bleed the system of air.

BUCKET CONTROL CYLINDER:

The packing is replaced in the bucket control cylinder similar to the boom hoist. The pivot pins must be removed to free the cylinder from the bucket carrier and the bucket. Unscrew the packing nut and follow the procedure outlined for the boom hoist packing replacement.

HYDRAULIC OIL RESERVOIR:

The oil reservoir is located just in back of the operator's seat and up under the engine hood. The oil level must be maintained up to the dip stick level when the bucket is resting on the ground. This will insure a quantity of oil sufficient to displace the cylinder plungers in order to raise the boom and bucket. The dip stick is found by removing the breather cap. Keep the oil level up to the "full" mark in the dip stick.

There are no adjustments on the reservoir; however, it should be drained, cleaned of dirt and sludge and refilled with clean oil monthly. The suction line strainer is inside the tank over the suction line outlet to the pump. This strainer must be kept clean. A dirty strainer will retard the flow of oil to the pump and cause cavitation, the pump will howl and the boom will raise in a slow jerky manner. The tank breather should be washed out with clean gasoline periodically. Remove the hand hole cover to reach into the tank to remove the strainer, and to inspect the vents in the breather pipe.

To remove the reservoir, first remove the engine hood, drain the reservoir, and then disconnect the hoses at the valve. Remove the bolts holding the reservoir to the frame and lift out the reservoir, along with the valve which is bolted to the left side of the reservoir.

HYDRAULIC PUMP FOR HOISTS CYLINDERS:

This is a Pesco "pressure loaded" gear type pump and assembled for counterclockwise rotation viewing the drive end. The pump requires no maintenance except to replace seals or springs. The manufacturer does not recommend replacement of gears or bearing in the field.

If the pump does not develop sufficient pressure to operate the hoists satisfactorily and the cause cannot be determined, see THE FRANK G. HOUGH CO. dealer for details on repair and replacement of the pump.

Before removing the pump cover from the body to replace seals, put match marks opposite each other on both parts so they can be reassembled for correct rotation.

To remove the pump from the machine, first remove the engine hood sides. Disconnect the pump hoses and plug or cork the hoses on the valve side. Remove the bolts holding the pump to the pump mounting bracket, loosen the chain coupling and draw pump away from the bracket.

To remove the drive shaft seal, remove the Woodruff Key and coupling gear from the shaft, loosen the four screws from the thrust plate and slide the thrust plate and gasket off the drive shaft. The drive shaft seal is pressed into the thrust plate and should be replaced at each overhaul. The drive shaft seal is procurable only as an assembly and can be removed by pressing the stationary seat parts out of the thrust plate and lifting the movable seal parts off the pump shaft.

Remove the nuts which secure the cover to the body (first placing match marks on each part) to remove the cover for replacement of the body gasket, rubber seal rings or spring plate.

To inspect the bore valve ball seat and ball, remove the hex. head retainer, gasket, spring and ball from the valve bore of the body. The ball valve seat is a press fit in the valve bore and should not be replaced unless damaged. To remove the seat thread a suitable pipe tap into the seat and heat the body to 200° F. The seat can be pulled out by using the tap as a puller.

If the ball seat is only slightly scratched place the ball in the seat and tap the ball with a soft hammer or mallet. Wash pump parts in clean, unleaded gasoline and dry by blowing with compressed air.

HYDRAULIC VALVE:

The hydraulic valve receives oil under pressure from the pump and directs it to the hoists. When the valve plungers are in "Hold" position, the oil already in the hoists is retained therein but oil from the pump flows thru the valve back to the reservoir. In "Raise" and "Close" positions, the oil from the pump is directed into the respective hoist cylinders. In "Lower" or "Dump" positions the oil returns from the hoist cylinders, thru the valve and into the reservoir along with oil coming from the pump.

No adjustments are to be made other than to remove the valve from the oil reservoir and wash it out with clean gasoline every 400 to 600 hours of operation. Whenever the oil in the reservoir is very dirty or dirt is forced into the valve when cleaning the reservoir, the valve must be removed and washed out.

Springs and seals may be replaced when necessary, but the manufacturer does not recommend replacement of the plungers as they have been fitted

to the body at the factory to maintain close tolerances.

The hydraulic valve is mounted to the left hand side of the reservoir. To remove the valve proceed as follows:

1. Drain the oil reservoir. It is not necessary to drain the entire system.
2. Disconnect the hoses from the valve.
3. Unscrew the capscrews holding the valve to the valve mounting plate and the valve will come away from the reservoir.
4. Note the "O" ring oil seal at the valve discharge opening into the reservoir. This ring must be in good condition, otherwise discard it for a new ring. Be sure to replace this "O" ring carefully when reassembling the valve to the reservoir to avoid pinching the ring because of a poor seat.
5. After the valve is bolted to the reservoir, connect the hoses. Refer to the hydraulic diagram to note the proper connection points. Be sure the connections are tight and will not leak oil. Refill the reservoir with the proper oil to "full" mark on the dip stick. Operate the hoists several times. Shut off the engine with the bucket on the ground. Inspect the connection points, then recheck the oil level in the reservoir and "bleed" the system of air.

TRANSMISSION AND REAR AXLE:

This is a four speed forward and reverse transmission. For major repairs to the transmission or rear axle use the extensive facilities offered by THE FRANK G. HOUGH CO. dealers.

Breathers must be cleaned and kept open to protect grease seals and gaskets.

Be sure all three sections of the final drive are filled with grease. See Grease Chart.

Greases should not be mixed, use the same brand when adding grease.

ENGINE:

All adjustments for the engine will be found by consulting the engine manual. See Specifications and Service Data pages in the front of this book for engine data.

TO REMOVE ENGINE AND TRANSMISSION:

1. Remove hood sides, air-cleaner and hood top.
2. The fuel tank is mounted under the grille so be sure to close fuel line shutoff cock and discon-

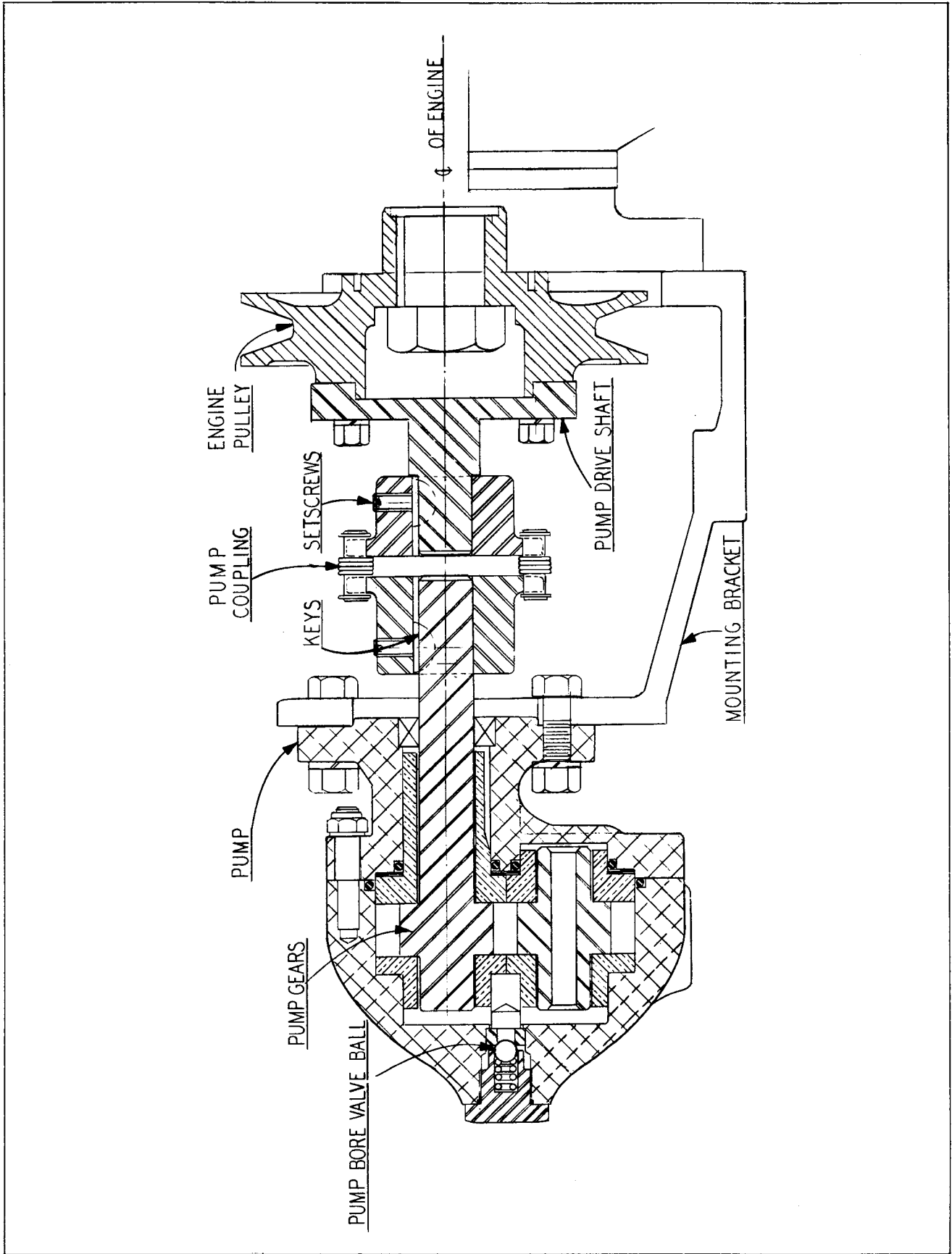

Fig. 5
PUMP MOUNTING

nect the fuel lines before removing the grille casting.

3. To remove the reservoir, first drain the hydraulic system and then disconnect the hoses at the valve and pump. Disconnect valve controls and then remove bolts holding the reservoir to the frame and lift out the reservoir along with valve which is bolted to the side of the reservoir.
4. Be sure to remove or disconnect all attachments or connections such as foot accelerator rod, choke rod, wiring loom, battery cables etc., before removing engine.
5. The Engine Unit is mounted to the frame in three points and these bolts must be removed in order to lift the engine, transmission, radiator and pump out as one unit.
6. Pass chain slings or stout rope under and around the engine unit to support it front and rear. Hook the slings to a crane and lift the engine slightly and move to rear to disengage spline shaft from universal joint. It will be necessary to relocate chain sling around transmission to by-pass the boom pivot housing before completing the removal of the engine unit.

FAN BELT REMOVAL:

Untimely shutdowns or damaged radiators may be avoided by frequent replacement of the fan belt. The fan belt should be inspected at each monthly service period and replaced if it shows signs of deterioration. If the machine is laid up for a time, it is good practice to ease the fan belt tension. Belts will deteriorate if allowed to remain taut for prolonged periods when not subjected to normal action.

To replace Fan Belt proceed as follows:
(See picture Pump Mounting)

1. Shut off the engine with bucket resting on the ground and remove hood sides.
2. Unloosen the set screws unlocking the pump coupling keys to the pump and the flanged shaft.
3. Remove the capscrews holding the pump to the mounting bracket and pull the pump to the rear as far as it will go. It will not be necessary to disconnect pump hoses.
4. Slide the coupling to the rear until it slides off the flanged pump drive shaft, and withdraw from the machine.
5. Then loosen generator bracket adjusting nut and push the generator in toward the engine and tighten the nut.
6. Remove the fan belt from generator pulley and lower fan belt pulley; then slip the belt over the fan.

FAN BELT ADJUSTMENT:

Install the new fan belt by reversing the method of removal. With the fan belt on all three pulleys, reset the generator so the belt may be flexed sideways by hand. This is the proper tension of the belt when the generator adjusting bolt is tightened. Never have the belt adjusted so tight that it feels stiff and taut.

AIR-CLEANER SERVICE:

A regularly serviced and properly working air-cleaner contributes considerably to the long life of an engine. Surprising amounts of foreign particles are present in most atmospheres and the abrasive action of such dust and dirt particles causes rapid wear on the valves, bearings and cylinder walls when it is carried into the engine. The purpose of the pre-cleaner is to collect grit and dirt before it reaches the engine. Thus the cleaner itself must be cleaned as often as dirt accumulations start to build up. Sometimes the cleaner must be cleaned and the oil in it changed several times a day if conditions are especially bad. Daily servicing of the air cleaner is important.

DRIVE SHAFTS:

The drive shaft is a Blood Bros. Double Center Universal Joint. It is imperative that the joints are kept well lubricated at all times. There are no adjustments to be made on these joints. Use a high grade grease which will resist separation under the attendant centrifugal action of the joint.

To break the joints remove the four capscrews holding the halves together and remove snap rings.

To disassemble the joint after removing from the machine, remove the snap rings and place one of the arms of the joint in a vise. Use a soft hammer to tap one of the unsupported ears to drive the top bushing outward. Then fasten this bushing in the vise to drive the joint off the bushing. The center cross can now be removed.

BRAKES: "BLEEDING"

The foot brakes are hydraulically operated, internal expanding, two shoe type in both rear wheels.

The hydraulic brake system must be "bled" whenever air gets in the system through a leak or when a line has been disconnected. Air trapped in the system gives a "spongy" feel to the brake pedal and, being compressible, does not allow pressure applied to the brake pedal to be transmitted solidly through the lines to the brakes. The system must be free of air at all times.

To bleed the brakes proceed as follows:

1. The longest fluid line from the master cylinder

Fig. 6
WIRING DIAGRAM

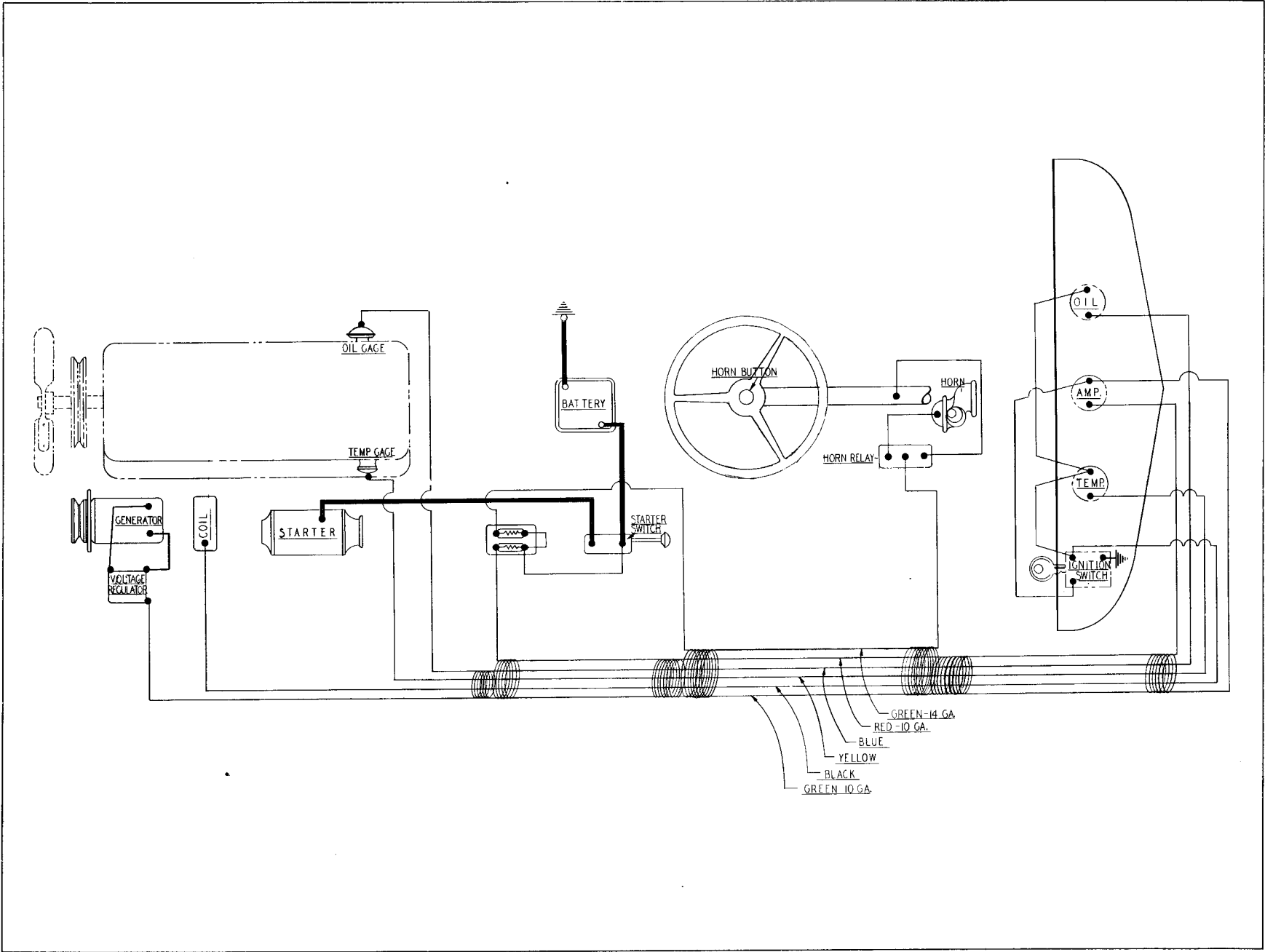

should be bled first. Proper sequence is bleeding the left wheel and then the right.

2. Carefully clean off all dirt from around the master cylinder filler plug, remove the plug and fill the master cylinder with hydraulic brake fluid.
3. Remove the dust cap from the left brake breather valve, first cleaning off the bleeder connection. Insert a hose into the valve and submerge other end of the hose into a jar containing a small amount of brake fluid.
4. Loosen the breather valve about 1/8 turn and pump the brake pedal several times being careful not to pump all the brake fluid out of the master cylinder. Do not allow the end of the hose to emerge from the fluid in the jar while the valve is open or air will be sucked back into the brake lines.
5. Refill the master cylinder with brake fluid and continue to pump the pedal until air bubbles are no longer seen escaping from the fluid in the jar.
6. Tighten valve, replace dust cap and repeat the operation of the right wheel.
7. Refill master cylinder when both wheels have been bled and replace the plug.

BRAKES-ADJUSTING:

When the brake linings become worn as indicated by the foot pedal going down almost to the floor-board, it is necessary to adjust the brake shoes. Inspect the brake linings periodically for wear. To adjust lining clearance, proceed as follows:

1. Jack up the rear axle and remove the wheel. Newer hubs are fitted with brake inspection holes making it unnecessary to remove the wheel. Merely jack up the wheel and remove the inspection hole cover.
2. Remove the 5/16 bolt to loosen the inspection cover on the brake drum.
3. Use a .010 feeler gauge thru the slot in the brake drum until .010 clearance is obtained on the top and bottom of the front shoe. It is necessary to turn the anchor screw to adjust the shoe. Loosen the anchor screw lock nut to adjust.
4. Turn the brake drum slot to opposite shoe and adjust top and bottom until .010 clearance is obtained. Note there are two anchor screws, one for each shoe.
5. Lock the anchor screw when adjustment is satisfactory and try the feeler gauge in top and bottom of each shoe again to make sure the adjustment was not upset when locking the anchor screws. Replace the wheel.
6. Repeat above on the other wheel.

PEDAL ADJUSTMENT - BRAKES:

Free pedal play must be apparent at the top of the stroke of the brake pedal, so that approximately 1/8" clearance is maintained between the master cylinder plunger and the end of its actuating rod.

Lack of free pedal play results in the master cylinder plunger being depressed, causing undue wear on the brake lining. Free pedal play is the amount of movement of the pedal before the actuating rod contacts the cylinder plunger. To obtain the correct amount of free brake pedal play, adjust the master cylinder actuating rod.

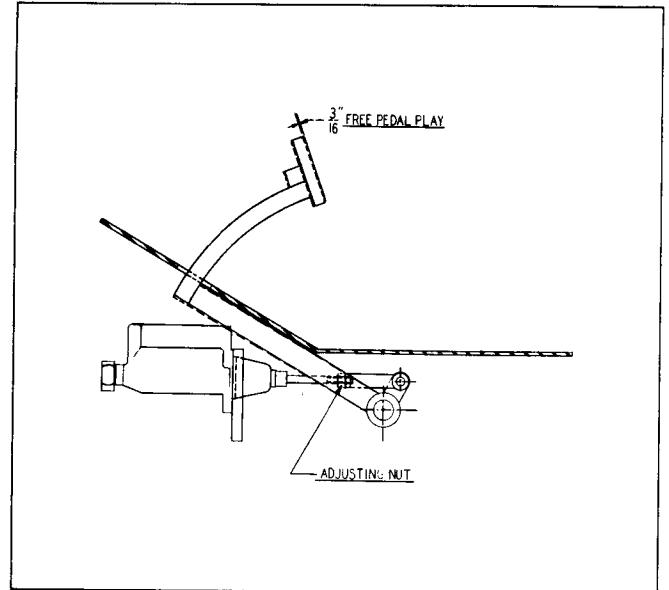

Fig. 7
BRAKE PEDAL ADJUSTMENT

It is good practice to overhaul the master brake cylinder and wheel cylinders whenever the brakes are relined.

CLUTCH ADJUSTING:

The clutch is a spring loaded, foot operated type. No adjustments for wear are provided in the clutch itself. The clutch pedal must have 1" to 1-1/2" of free pedal play which is the amount of movement of the clutch pedal before the clutch release bearing contacts the clutch release levers. Lack of clutch pedal play causes undue wear on the clutch facings and bearings.

It is imperative that the pedal be readjusted at frequent intervals to obtain this clearance.

To readjust the clutch pedal remove the clevis pin and turn the clevis on the clutch control rod until the necessary free movement of the pedal is obtained. It may be necessary to adjust the clevis several times to reach the proper amount of free play.

Be sure to tighten the lock nut against the clevis to maintain adjustments.

The importance of proper use of the clutch pedal during operation will save considerable wear on the clutch release bearing and the clutch disc. "Riding" the clutch causes rapid wear on the clutch release bearing and the tendency to "feather" the clutch results in premature wear on the clutch disc. The clutch pedal should never be depressed except during the time required to shift gears.

CLUTCH REMOVING:

1. Disconnect the clutch control rod at the clutch arm.
2. Take out the twelve 3/8" capscrews to remove the clutch housing cover.
3. Remove the capscrews holding clutch pressure plate to the engine flywheel and lift complete pressure plate out of the flywheel housing along with the clutch drive plates.

STEERING ADJUSTMENTS:

LUBRICATION OF STEERING GEAR:

The steering gear is filled at the factory with a special steering gear lubricant developed for both summer and winter operation. Seasonal change of lubricant and draining of gear case is not necessary.

Gear should be kept filled to level of filler plug with correct lubricant. Add GMC #4673-M Lubricant to keep full.

STEERING GEAR ADJUSTMENT:

Correct steering gear adjustment is very important. There are only two adjustments to be made but the following procedure must be adhered to, step by step. See Fig. 8 and 9.

1. Disconnect drag link from pitman arm, taking care to note relative position of drag link to pitman arm, before disturbing them.
2. Disconnect upper steering column brace to make sure there is no bind in the column due to anchorage.
3. Loosen lock nut "A", Fig. 8, then turn lash adjuster "B", a few turns counterclockwise. This relieves the load upon the screw bearings imposed by the rack and sector teeth. Turn steering wheel GENTLY in one direction until stopped by gear, then back one turn. Do not turn steering wheel hard against stops when gear is disconnected. Damage to ball guides may result.
4. Measure the pull at the rim of the wheel which is required to keep the wheel in motion. This pull can be measured by attaching a spring scale to the rim of the wheel with a piece of cord, then pulling on the spring scale to turn the wheel.

The line of the scale should be kept tangent to the rim of the wheel. The proper value of the pull at the wheel rim under these conditions is 1-1/2 to 2 lbs. If the actual value does not lie between these limits specified, adjustment of the screw bearings is necessary.

Fig. 8

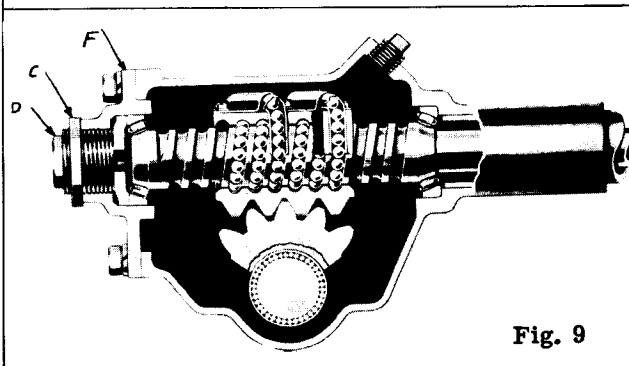
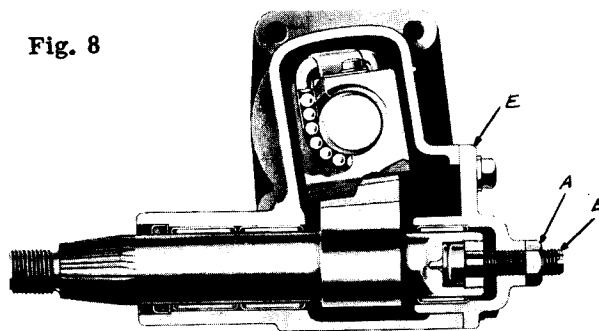

Fig. 9

5. To adjust screw bearings, loosen lock nut "C" Fig. 9 and turn screw bearings adjuster "D" clockwise until there is no perceptible end play in screw. Check pull at wheel rim as above, readjusting, if necessary, to obtain proper pull. Set up lock nut "C" and recheck pull, as it must lie within the specified limits AFTER the lock nut is set up. If gear feels "lumpy" after adjustment of screw bearings, there is probably damage in the bearings due to severe impact or to improper adjustments, and the gear must be torn down for replacement of damaged parts.
6. After proper adjustment of screw bearings is obtained, and all mounting bolts securely tightened, adjust lash adjuster "B" Fig. 8. First turn steering wheel GENTLY from one stop all the way to the other, carefully counting the total number of turns. Then turn wheel back exactly half way to center position. Mark wheel at top or bottom center with piece of tape. Turn lash adjuster "B" clockwise to take out all lash in gear teeth, and tighten lock nut "A". Check pull at wheel rim as before, taking the highest reading of the spring scale as the wheel is turned through center position. Proper value of pull is 2-1/2 to 3 lbs. Readjust, if necessary, to obtain proper pull. Set up lock nut "A" as it must lie within the limits specified AFTER the lock nut is set up.
7. Reassemble steering connecting rod to pitman arm. (See Pitman Arm - Steering.)

TOE-IN ADJUSTMENT:

The steering arrangement is of a single tie rod type and the front wheels should be adjusted to 0" to 1/4" or approximately 1/8" toe-in for each front wheel.

To adjust toe-in loosen the two nuts clamping the tie rod ends to the tie rod. Turn the tie rod until wheels are adjusted. Be sure to retighten the nuts, two on each tie rod end.

TURNING RADIUS ADJUSTMENT:

If, for any reason, the steering gear pitman arm must be removed, put match marks on both the arm and the serrated shaft, so the arm can be relocated in its original position.

Care must be exercised in locating a new pitman arm. Under no circumstances should the pitman arm be so located on the serrated pitman shaft so that the turning of the front wheels is stopped by resistance within the steering gear, before being halted by the axle stop blocks.

Suggested pointers in locating a new pitman arm on the pitman shaft are as follows:

1. Check and adjust front wheels for correct toe-in (See TOE-IN ADJUSTMENT.)
2. Connect the drag link to the left steering arm ball; connect pitman arm ball to the drag link ball joint.
3. Place a jack under the front axle radius rod pivot and jack up the front end of the PAY-LOADER high enough to allow the front axle to oscillate up and down fully. And at the same time permit the wheels to turn thru their full turning angle.
4. Turn the steering wheel GENTLY to the right (as in making a right turn) until stopped by resistance within the steering gear. Then back off the steering wheel by not less than a 1/4 turn.
5. Tilt right wheel upward and hold the axle against the frame axle oscillating stop. Swing the front wheels as in making a full right turn. The spindle steering arm now rests against the axle stop block. Hold the wheels and steering gear wheel in positions described above. Slip the pitman arm on the end of the serrated pitman shaft protruding from the steering gear, but do not tighten. If necessary the steering wheel should be backed off slightly more than the 1/4 turn to match serrations in the arm and on the shaft. Never match serrations with less than the 1/4 turn safeguard.

6. Now tilt the axle so the left wheel is up and hold the axle against the left frame axle stop. Turn the steering wheel GENTLY until the front wheels are in a full left turn position. Note carefully to see that the left spindle steering arm is stopped by the axle stop block before stopped by resistance with the gear. Slip the pitman arm off the serrated pitman shaft to be sure there is approximately 1/4 turn left in the steering wheel after the turn of the wheels is stopped by the axle blocks.

The pitman arm may then be fastened securely to the serrated pitman shaft protruding from the steering gear.

7. Never allow the resistance within the gear to be used to stop the turn of the front wheels for either a full left or right turn.

It may be possible that thru use and wear on the assembly, the spindle arm stops are no longer adequate. In this event, adjustment must be made by turning up the screws in the axle stops so they stop the turn of the front wheels before resistance within the gear stops the turn of the wheels. This must be done to protect the steering gear bearings and ball nut within the gear.

TIRE PRESSURES:

Front tires are 7.00 x 20 - 8 ply and should contain fifty-five (55) pounds air pressure.

Rear tires are 12.00 x 24 - 6 ply and should be three-fourth (3/4) full of calcium chloride solution with 25 pounds air pressure.

Secure a "bleeder" adapter from an authorized tire dealer to allow air in the tire to escape when being replaced by liquid. Jack up the PAYLOADER and turn the tire so the valve stem is on top. Turn out the valve core, screw in the adapter and attach the water hose to the adapter. Place the container holding the calcium chloride solution somewhat higher than the tire (about 5 or 6 feet). Put the solution in the tire tube by using a hand pump or by using compressed air and a pressure tank filled with liquid. Fill the tube until the liquid level is slightly below the valve stem level. Remove the hose and adapter, replace the valve core and inflate the tire with air until the tire gage registers 25 pounds.

To make the proper calcium chloride solution be sure to put 33-3/4 gallons of water in the container first. Then add 117-3/4 pounds of calcium chloride. Stir the solution until thoroughly mixed and allow to cool before using.

NOTE: Calcium chloride solution is injurious to metal and should never be used in the cooling system.

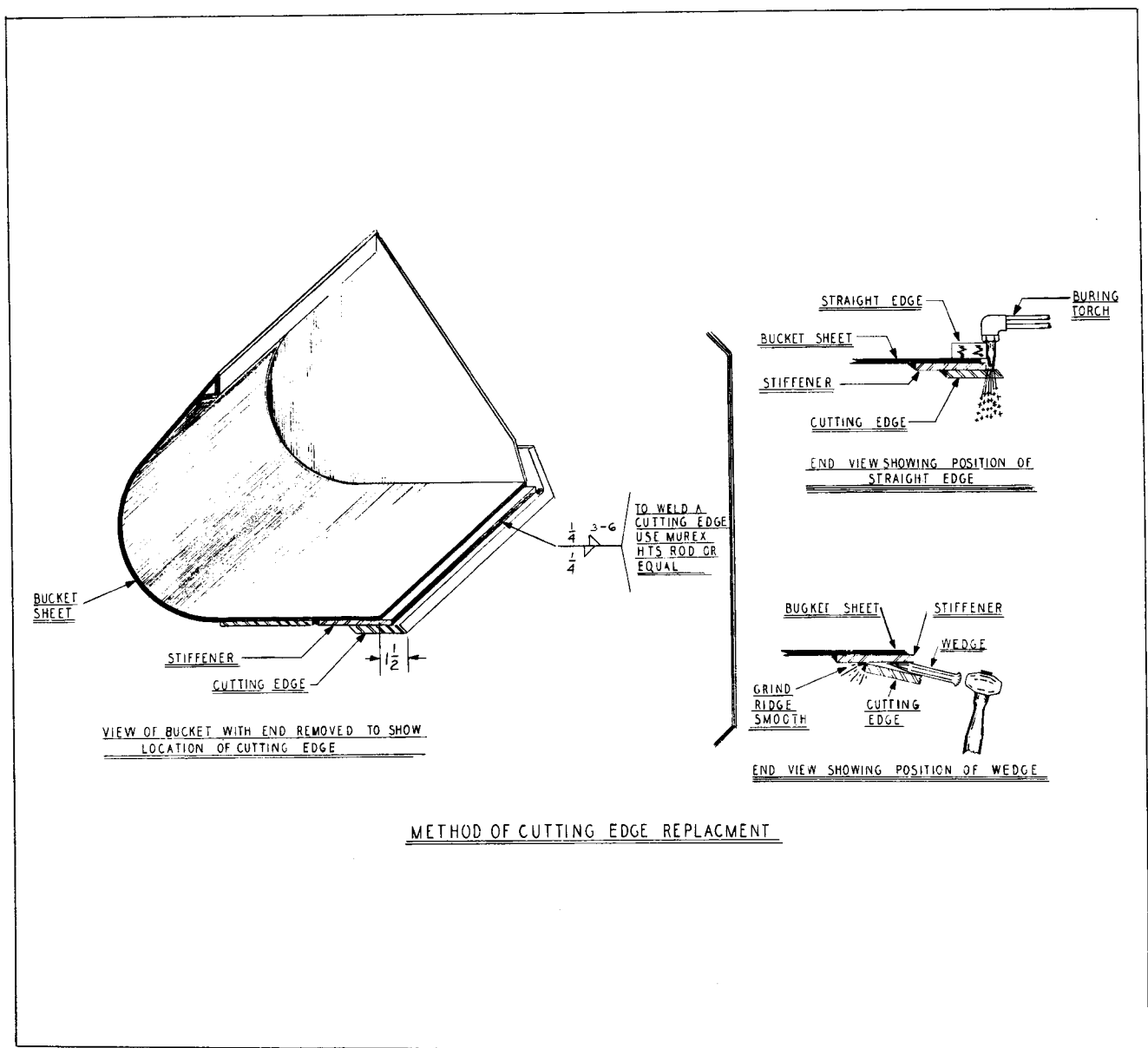

Fig. 10
METHOD OF CUTTING EDGE REPLACEMENT

TO REPLACE THE CUTTING EDGE FOLLOW THE PROCEDURE OUTLINED BELOW

1. Lay a straight edge in the bucket to line up with the edge of the stiffener and clamp in place. If there is no stiffener on the bottom of the bucket, line the straight edge with the edge of the bucket sheet.
2. Guide the burning torch along the straight edge to cut through the cutting edge and the weld along the front edge.
3. Follow a similar method for the upright ends of the cutting edge. Burn through the width of the cutting edge at the bends. Burn off the top weld of the ends with a gouging tip.
4. Drive a cold chisel or wedge between the stiffening and the cutting edge to break the back weld. Force the chisel between the bucket sides and the side portion of the cutting edge to remove the remaining ends.
5. Clamp the new cutting edge in place 1-1/2 inches beyond the edge of the bucket sheet as shown in Fig. 5. Bucket sheet and sides must be straight before welding on the cutting edge.
6. Back step a continuous 1/4 fillet weld on the front joining the cutting edge to the stiffener and to the bucket sides. If bucket has no stiffener weld the edge to the bucket sheet. Join the back edge to the stiffener or bucket sheet with 1/4 fillet welds 3 inches long on 6 inch centers. Use "Murex" 7/32 HTS rod or equal at no more than 200 amperes.

LUBRICATION POINTS - HE "PAYLOADER"

Refer to the Lubrication Chart to locate the following points. Before servicing always wipe the dirt from around the grease fittings, cups, or plugs, to prevent grit and dirt or other foreign matter from entering.

SERVICE DAILY - Items 1 thru 19; use a good grade of general purpose pressure gun grease. Give 3 or 4 strokes daily to each fitting to force out old grease and dirt.

1. Bucket Hoist - Upper & Lower Pivots . 2 Points
2. Hinge Pins - 1 Each, R.H. & L.H. Side . 2 Points
3. Boom to Carrier - 1 Each, R.H. & L.H.
Side 2 Points
4. Boom to Frame - 1 Each, R.H. & L.H.
Side 2 Points
5. Guide to Frame - 1 Each, R.H. & L.H.
Side 2 Points
6. Boom Hoist Pivots - 2 Each, R.H. &
L.H. Side 4 Points
7. Bolster Pin - Axle Pivot 1 Point
8. Radius Rod Pin - Axle Pivot 1 Point
9. Drag Link - 1 Each, Front & Rear
Ends 2 Points
10. Tie Rod Ends - 1 Each, R.H. & L.H.
Ends 2 Points
11. Spindles - 2 Each, R.H. & L.H. Sides . . 4 Points
12. Clutch Shaft - 1 Each, R.H. & L.H.
Housing 2 Points
13. Valve Rod Pivots - 1 Each, Bell
Crank 2 Points
14. Bucket Control Lever - Left Side of
Seat 1 Point
15. Boom Control Lever - Left Side of
Seat 1 Point
16. Direction Lever - Center of Floor-
board 1 Point
17. Range Lever - Left Side of Floorboard. 1 Point
18. Foot Pedal Pivots - 1 Each, R.H. &
L.H. Floorboard 2 Points
19. Accelerator Rod - 1 Each, R.H. & L.H.
Floorboard. 2 Points

SERVICE DAILY - Items 20 thru 28; check and service per instructions as follows.

20. Clutch Release Bearing - Give on shot sparingly, using a hand gun. Do not over lubricate this bearing. Use the best obtainable grade of high temperature lubricant such as "LUBRIKO M24" or equal. This grease fitting is located on the left side of the clutch housing.
21. Fuel Tank Filler Cap - Fill the tank with clean fuel. Use a gasoline of 70-72 min. octane rating.
22. Fuel Line Shut-Off Cock - Always close the fuel line shut-off cock when leaving the machine stand idle over night or longer.
23. Air-Cleaner Cup - Clean and refill daily or

oftener as required. This is Important. To clean, remove the cup and wash it out in clean kerosene.

24. Engine Oil Lever Dipstick - Check the crankcase oil level daily or oftener if required. Add oil as required to maintain the oil level up to the "full" mark on the dipstick. Do not check the oil level while the engine is running. See Item 33.
25. Hydraulic Oil Reservoir Dipstick - Check the hydraulic oil level daily. Add oil as required to maintain the oil level up to the "full" mark on the dipstick. The bucket must be fully retracted and resting on the ground, and the engine shut off, when checking the reservoir oil level.
26. Battery - It is good practice to check the battery at each daily inspection period. Add distilled water or clean rain water to keep the plates covered with fluid.
27. Radiator Filler Cap - Do not run the engine without a full quantity of coolant in the radiator. Always use clean, soft water, free from alkaline, in the radiator. Add a reliable anti-freeze solution to the cooling system when operating in freezing temperature of 32°F or lower.
28. Radiator Drain Cock - When necessary to drain the cooling system, remove the radiator cap and open both the radiator and engine block drain cocks. "See Draining the Cooling System."

SERVICE WEEKLY OR AS SPECIFIED - Items 29 thru 48; check and service as specified in the following instructions.

29. Drive Shaft - Two points. Lubricate these points sparingly with a general purpose grease, weekly. Use a hand gun or low pressure gun.
30. Generator - Give 2 or 3 drops of light lubricating oil to each cup weekly. There are two cups.
31. Starter Motor - Give 2 or 3 drops of light lubricating oil to the starter motor cup weekly.
32. Distributor - Give 2 or 3 drops of light lubricating oil to the distributor cup weekly.
33. Engine Crankcase Filler - Drain and refill the engine crankcase with a good grade of clean oil weekly. Refer to the Waukesha Engine Manual for engine maintenance instructions. In general, use SAE 30 motor oil when operating in hot summer temperatures and SAE 20 motor oil in moderate temperatures. Use SAE 20 motor oil when operating in cold, winter temperatures. It must be remembered that oil specifications of various companies may differ, although the oils are designated by the same SAE number. Consult the

sales department of a reliable oil manufacturer to obtain assistance in selecting the proper grade of engine oil.

The crankcase breather pipe must be washed out in clean kerosene whenever the crankcase oil is changed, or oftener if operating conditions are very dusty or dirty. This breather is located on the rear valve door of the engine. Remove to clean thoroughly.

34. Crankcase Drain Plug - Located under the crankcase pan. Remove this plug to drain the engine crankcase.
35. Crankcase Oil Filter - Located on the lower right side of the engine. Drain, clean, and place a new element in the filter weekly when changing the crankcase oil. Read and follow the instructions as set forth on the box containing the new element when replacing a used element. Be sure the cover gasket is in place and the cover tightened after inserting the new element. When the crankcase oil has been changed and a new element placed in the filter, start the engine. Let it run at idle speed for about 10 minutes to saturate the new filter element with oil. Then shut off the engine and recheck the oil level in the crankcase as it will have been lowered by oil being retained in the filter. Be sure the crankcase oil level is up to the "full" mark on the dipstick. Then inspect the oil filter for oil leaks due to a faulty gasket or a loose cover.
36. Hydraulic Oil Reservoir Filler - Drain, clean, and refill the hydraulic system with clean SAE 10 motor oil monthly. When draining, remove the hand hole cover from the top of the reservoir and reach into the tank to remove the suction line strainer. Wash the strainer in clean gasoline. Clean the air vents of the tank breather. See "Draining the Hydraulic System."
37. Hydraulic Oil Reservoir Drain - Remove this plug when necessary to drain the reservoir. It is a magnetic type and must be cleaned before replacing.
38. Hoist Cylinder Bleeder Plugs - There are three plugs, one on the upper end of each hydraulic cylinder. Unscrew to "bleed" the system of air after any work has been done on the hydraulic system, or when the system has been drained and refilled with clean oil. See "Bleeding the System."
39. Differential Filler and Level Plug - Keep full to the height of this plug, located on the side of the differential housing. Use SAE 140 differential oil when operating in summer temperatures and SAE 90 differential oil in cold, winter temperatures. Check the oil level weekly, drain and refill monthly.
40. Reduction Gear Case Oil Level & Filler Plug - Located on the inside of each drive wheel housing. Use SAE 140 oil when operating in summer temperatures and SAE 90 oil in cold, winter temperatures. Keep full to the height of these plugs. Check the oil level weekly, drain and refill monthly.
41. Differential Drain Plug - Remove the plug to drain the drive axle differential housing. It is located on the underside of the housing. Always clean the housing breather air vents when draining the housing.
42. Reduction Gear Case Drain Plug - Remove these plugs to drain the drive wheel housing. There are two plugs, one on the underside of each drive wheel housing. Clean the housing breather air vents when draining the oil. Always clean all drain plugs before replacing them.
43. Transmission Filler and Oil Level Plug - Keep the transmission housing oil level up to the height of the oil level plug. Use a good grade of clean SAE 90 transmission oil when operating in either summer or winter temperatures. Check the oil level weekly, drain and refill monthly.
44. Transmission Drain Plug - Remove this plug to drain the transmission housing. Clean the plug before replacing it. Clean the breather air vents when draining the oil.
45. Wheel Hubs - Steering Axle - Repack monthly; use a good grade of wheel bearing grease.
46. Steering Gear Filler - Keep full to the height of the filler pipe cap. Use G.M.C. #4673 M summer and winter.
47. Master Brake Cylinder - Keep full with hydraulic brake fluid.
48. Water Pump - Two types of water pumps have been used on the engines. One type is permanently packed and sealed, and requires no further lubrication. The other type is fitted with a grease cup. This cup must be filled with a good grade of water pump grease. Give the cup one turn weekly.

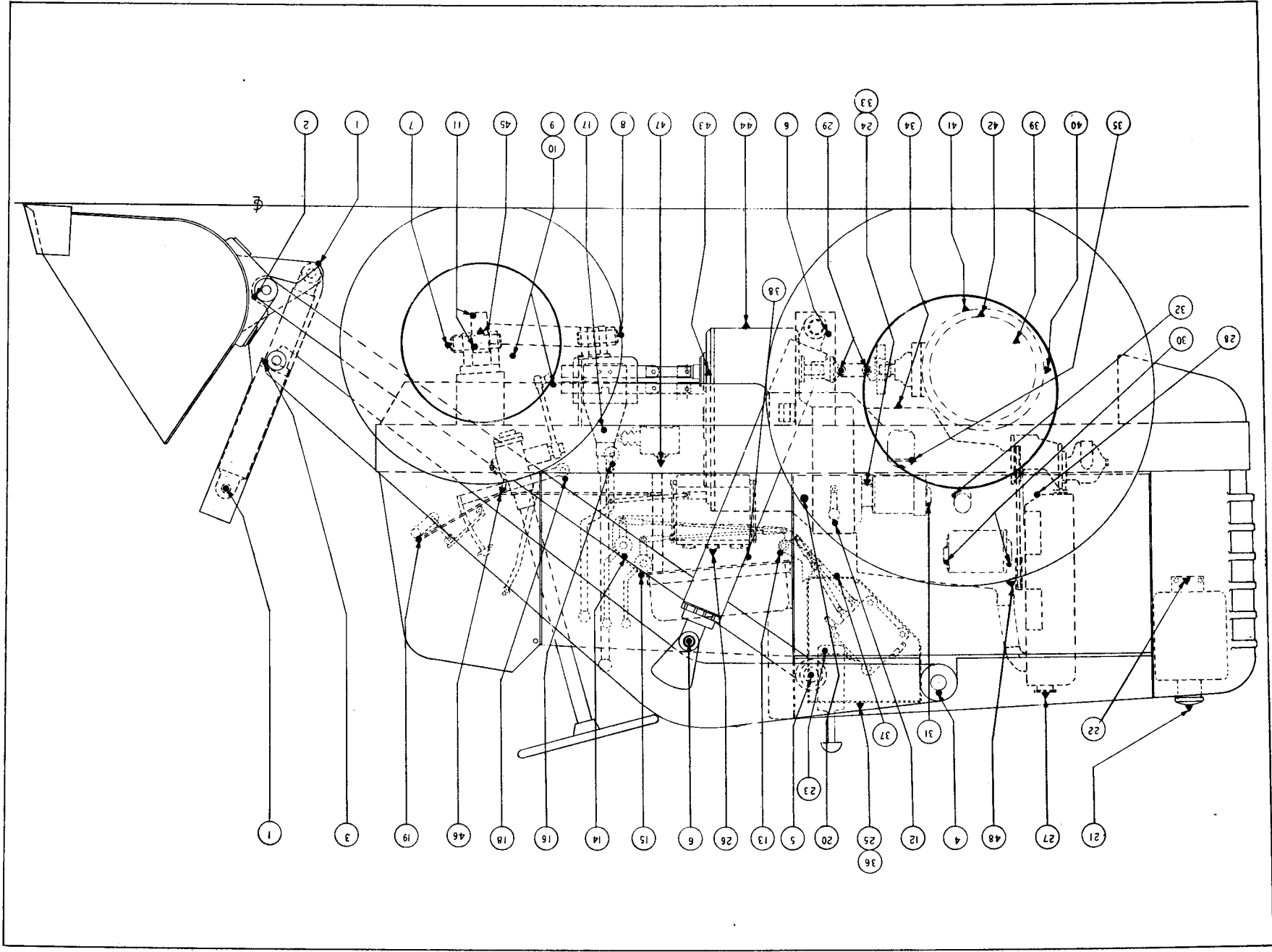

Fig. 11
LUBRICATION CHART