



Parts List

HERCULES

ENGINE *and* POWER UNIT

of the

“OO” Series

OOA—3½" x 4½"

OOB—3¾" x 4½"

OOC—4" x 4½"

JULY 1, 1937

Supersedes All Previous Parts Lists

HERCULES MOTORS CORPORATION

CANTON, OHIO, U. S. A.

PARTS LIST

HERCULES

FOUR CYLINDER ENGINE

of the

OO Series

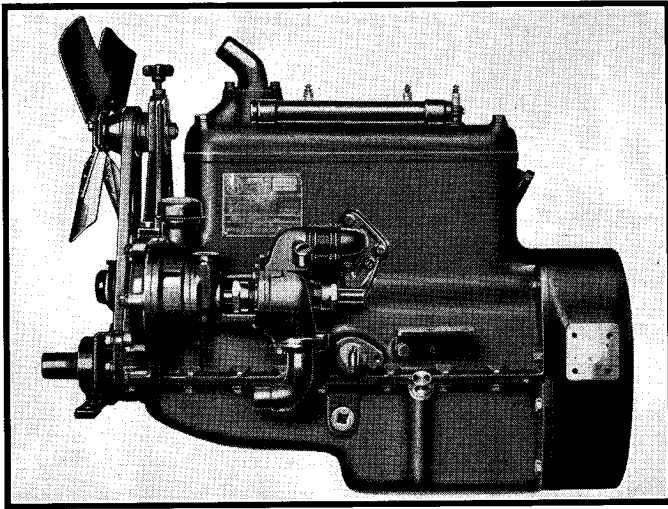

HERCULES MOTORS CORP.

CANTON, OHIO, U. S. A.

HERCULES MOTORS CORPORATION

Canton, Ohio

STANDARD WARRANTIES, FIELD SERVICE, RETURNS AND EXPENSES ISSUED BY THE INTERNAL COMBUSTION ENGINE INSTITUTE, OCTOBER 20, 1933.

HERCULES MOTORS CORPORATION is a MEMBER of THE INTERNAL COMBUSTION ENGINE INSTITUTE and all engines, power units, parts and accessories are sold by us subject to the terms of the "STANDARD WARRANTIES, FIELD SERVICE, RETURNS AND EXPENSES" of said Institute adopted and issued October 20, 1933 and all amendments thereof which may be in effect from time to time hereafter. The following is a copy of the terms of the "Standard Warranties, Field Service, Returns and Expenses" issued October 20, 1933, but it is subject, however, to future amendment without notice. Notwithstanding any different terms or conditions which may be contained in any customer's purchase order received by us, we will be governed by and conform to the terms and provisions of the "Standard Warranties, Field Service, Returns and Expenses" of The Internal Combustion Engine Institute.

1. STANDARD SERVICE WARRANTIES

The term "member of this industry" as used herein means a member of the Internal Combustion Engine Institute.

The term "Buyer," as used herein means a customer of a member of this Institute.

- a) The members of this industry shall guarantee their engines and parts thereof against defective material or workmanship as prescribed in paragraph 1-(b).
- | b) Type of Application | Warranty Period |
|------------------------------------|--|
| Bus and Truck Equipment | Six months from date of shipment but not to exceed ninety days or 15,000 miles of service. |
| Rail Cars and Locomotives | Six months from date of shipment but not to exceed ninety days or 15,000 miles of service. |
| Agricultural Equipment | Six months from date of shipment but not to exceed ninety days of service. |
| Industrial and Oil Field Equipment | Six months from date of shipment but not to exceed ninety days of service. |
| Marine Equipment | One year from date of shipment. |
| Fire Equipment | One year from date of shipment. |
- c) Parts returned to any member of this industry, transportation charges prepaid, which are found by the member to be defective in material or workmanship, shall at the member's option be repaired, replaced or credited. No claims will be allowed which, in the opinion of the member, result from engines or parts having been subjected to abuse or neglect or where failure has been caused by accident.
- d) Warranty on accessories furnished by each member shall be limited to the warranty of the accessory manufacturer.
- e) Any warranty is void unless the Buyer or his agents provide proper care and storage of engines and parts from date of shipment to date placed in service.

- f) Each member reserves the right to improve his product through changes in design or materials without being obligated to incorporate such changes in engines of prior manufacture.
- g) No responsibility for contingent liability through the failure of any engine or engine part will be assumed by a member of this industry.

2. FIELD SERVICE

- a) The responsibility of maintaining or arranging for adequate and proper field service facilities shall be with the Buyer, and he shall not request the assistance of any member of this industry except in cases of a complex character.
- b) All requests for service in the field shall emanate from the Buyer of the engines. Requests received from a Buyer's dealer or the ultimate user shall, under normal conditions, be referred to the Buyer.
- c) If a member renders field service at the request of the Buyer and the fault is found not to be with the engine, the Buyer shall pay the time and expense of the member's field representative.
- d) No member shall accept bills for service, labor or other expense that has not been previously approved and authorized.
- e) Before consideration can be given to requests for adjustments covering field service and alleged defective material, the Buyer shall furnish the member with the following data:

Owner's name and address.

Engine model.

Serial number.

Information as to the nature of the trouble.

Date actually placed in service.

Accumulated days or miles of service.

3. THE RETURN OF NEW MATERIAL

- a) Any member of this industry may at his option accept the return of any part or parts provided such return has been authorized, and at prices agreed upon, transportation charges prepaid. Such authorized returns shall be subject to the member's inspection and to a handling charge to ten percent (10%) of the cost of the part or parts returned.

4. LABOR AND OTHER EXPENSES

- a) No member of this industry shall assume any expense except direct labor in replacing parts or servicing engines within the warranty period, and in no case shall such expense be assumed unless authorized by the member.

The obligation hereinabove provided to repair, replace or credit at the option of Hercules Motors Corporation any engines, power units or parts that are found by it to be defective in material or workmanship is in lieu of any and all other warranties expressed or implied by law and all other obligations or liabilities on the part of Hercules Motors Corporation to the Buyer or to any other party.

HERCULES MOTORS CORPORATION
Canton, Ohio, U. S. A.

INSTRUCTIONS *for* ORDERING PARTS

This parts list supersedes all others of previous date.

All prices are subject to change without notice.

All shipments are strictly C. O. D., except when otherwise agreed to by contract with our company.

All parts are shipped F. O. B. Canton, Ohio, except Parcel Post packages, which are prepaid and billed to customer on the invoice.

When ordering by telegram or telephone, be sure to send us confirming order.

DO NOT order anything in sets; for example, "One set of Piston Rings" might be understood as meaning Four—a set for one Piston—or Sixteen—a set for one Engine.

When in doubt as to whether you can order from this parts book, send in a sketch, or the old part (prepaid) and specify on order "as per sketch," or "as per sample."

When ordering parts, give engine number.

If you return old part as sample be sure to advise us that you are doing so, and put a tag on the part with your name and address, so it may be quickly identified.

PARTS RETURNED FOR CREDIT

All claims must be made within **three** days after receipt of goods. Transportation charges must be prepaid. Never return a part to our factory without writing us a letter informing us what you are returning and why. Place on outside of box or package, tag showing name and address. Tag each article in box or package, stating what, how many, and why returned, specifying number of engine from which part was removed.

Your careful attention and adherence to the above instructions will assist us in giving you prompt and correct service.

**HERCULES MOTORS CORPORATION
CANTON, OHIO, U. S. A.**

JULY 1, 1937

Supersedes All Previous Parts Lists

Group and Illustration Index



	Text Page	Illus. Plate No.		Text Page	Illus. Plate No.
A			I		
Accessory Drive.....	22-24	4	Idler Gear.....	14	3
B			M		
Bearings, Main.....	6-8	1	Magneto Equipment.....	32	1
Bellhousing.....	26	8	Main Bearings.....	6-8	1
Breather.....	12		Manifold.....	30-32	5
C			Manifold Extension.....	32	5
Cable Tube.....	32	3	O		
Camshaft.....	12	3	Oil Filtrator.....	43	18
Connecting Rod.....	8	2	Oil Pan.....	26-28	6
Crankshaft.....	10	2	Oil Pump.....	28-30	5
Cylinder and Crankcase.....	6-8-44-45	1	P		
Cylinder Head.....	12-44-45	1	Piston.....	8-10-44-45	2
D			Push Rod.....	10	2
Distributor Gear.....	32	4	S		
F			Starter Attaching Parts.....	36	7
Fan Assemblies.....	24	8	Starting Crank.....	34-36	7
Fan Belts.....	24	8	Shim Assembly.....	8	
Fan Drive Parts.....	24	1	T		
Flywheels.....	24-26	8	Thermo Syphon Pipes.....	34	7
Front Support.....	34	7	Tools.....	43	
Fuel Pump.....	36		Trunion Bracket.....	36	7
G			V		
Gasket Assemblies.....	6		Valves.....	10	2
Gear Cover.....	12	1	W		
Generator Gear and Cover.....	32	6	Water Inlet Pipes.....	34	7
Governor and Valve Box Assemblies	42	9	Water Outlet Pipes.....	32-34	7
Governor Head Assembly.....	36-38-40	9	Water Pump.....	14-16-18-20-22	4
Governor Valve Box Assemblies.....	40-42	9			

INDEX FOR DIFFERENT MODELS

Internal parts not affected by bore changes are shown on pages 6 to 43.

SPECIAL PARTS

Model "OOA".....	Page 44	Power Unit.....	Pages 46 to 50
Model "OOC".....	Page 45	Kerosene Equipment.....	Page 51

PARTS LIST

Parts carrying mark ■ in front of part number have been selected as those necessary to care for emergency service and maintenance.

The quantity of such parts to be carried as spares will depend on the number of engines in service.

If gasket assemblies are ordered then gaskets shown under each group may be omitted to avoid duplication.

GASKET ASSEMBLIES

The following assemblies do not include gaskets for fan assemblies, special oil pans or any of the various accessories.

Part No.	No. Req.	PART NAME	Plate No.
22008-AS	1	Gasket Assembly-Primary, Includes parts marked *	
22003-C	1	*Cylinder Head Gasket-OOA-OOB-OOO.....	
22023-B	2	*Manifold Gasket.....	
22085-B	2	*Oil Pan Gasket.....	
22065-B	1	*Bellhousing Gasket.....	
22005-B	1	*Valve Cover Gasket.....	
22024-B	1	*Gear Cover Gasket.....	
4680-A	1	*Gear Cover Cork Seal.....	
4679-A	1	*Oil Pan Felt Seal.....	
87-A	1	*Water Outlet Gasket.....	
22001-AS	1	Gasket Assembly—Secondary—Includes parts marked **	
22564-A	1	**Fuel Pump Gasket.....	
10471-A	1	**Governor Gasket.....	
22164-A	1	**Water Pump Cover Gasket.....	
22149-A	1	**Water Pump Attaching Gasket (Also Accessory Drive).....	
22150-A	1	**Water Pump Discharge Pipe or Oil Filtrator Gasket.....	
22119-A	1	**Oil Pump Attaching Gasket.....	
22271-A	1	**Generator Attaching Gasket.....	
22028-A	1	**Companion Flange Gasket.....	
22328-A	1	**Companion Flange Gasket.....	
86-A	1	**Water Inlet Pipe Gasket.....	
58839-A	1	**Governor Body Gasket.....	
87-A	1	**Governor Valve Box Gasket (1 $\frac{1}{4}$ " SAE).....	
86-A	1	**Governor Valve Box Gasket (1" SAE).....	
2452-A	1	**Oil Filtrator Shell Gasket.....	
8575-A	2	**Oil Filtrator Drain Plug Gasket.....	

CYLINDER AND CRANKCASE

22100-ESY	1	Cylinder and crankcase, with valve guides, push rod guides, camshaft bearings and idler gear bearing.....	1
22319-DS	1	Cylinder and crankcase, with the above parts, also main bearings, caps and screws, all reamed to size.....	1
1609-A	7	Expansion plug (1 $\frac{1}{4}$ " Dia.).....	1
22070-A	1	Expansion plug (1 $\frac{7}{8}$ " Dia.).....	1
4312-A	2	Cylinder pipe plug, $\frac{1}{2}$ " Sq. head replaces 1075-A Socket type.....	1
■ 22040-B	2	Front and center main bearing (Upper).....	1
■ 22042-B	1	Rear main bearing (Upper).....	1
■ 22093-B	2	Front and center bearing cap, babbitted and machined.....	1
■ 22094-B	1	Rear main bearing cap, babbitted and machined.....	1

NOTE: A suitable allowance will be made for caps 22093-B and 22094-B if returned in condition to be rebabbitted and reused providing our invoice reference is given covering bearing cap which replaced the one returned.

1703-A	12	Main bearing cap screw, alloy steel ($\frac{9}{16}$ "x12x2 $\frac{1}{2}$ " U. S. S.).....	1
267-A	6	Main bearing cap screw lock wire (7" long).....	1

Give Engine Number with Each Parts Order

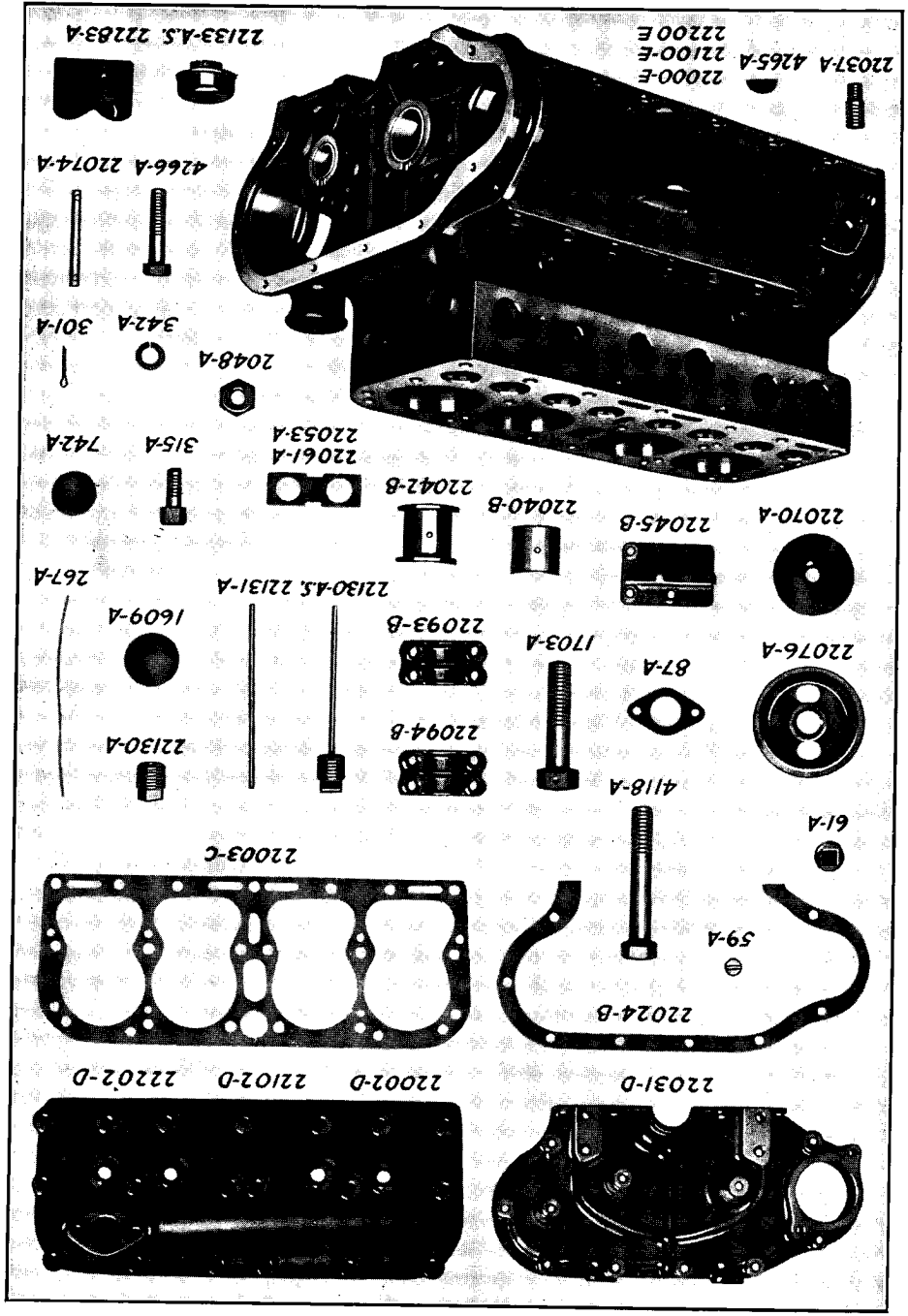

Plate No. 1

Cylinder Head, Gasket, Block, Main Bearings and Caps, Gear Cover and Fan Driving Parts

CYLINDER AND CRANKCASE (Continued)

Part No.	No. Req.	PART NAME	Plate No.
22061-A	As Req.	Main bearing shim (.002")	1
22053-A	12	Main bearing shim (.003")	1
22156-AS	1	Cylinder oil metering plug, tube and screen	
Takes Place of Part No. 22130-AS—Plate No. 1			

On all engines before engine number 227680 use oil metering plug assembly 22156-AS. This is different from the earlier type as it is shorter and has a screen covering the tube. On all engines after engine number 227680 use plug 22158-A in the hole in the end of the oil manifold as the oil is carried to the gear compartment through the idler shaft and gear.

22158-A	1	Cylinder oil metering plug	
60-A	1	Oil tube pipe plug 1 ¹ / ₄ "	
Takes Place of Part No. 61-A—Plate No. 1			
59-A	2	Oil tube pipe plug (1 ¹ / ₈ "x27" steel)	1
742-A	1	Oil tube expansion plug (1" diam. soft iron)	1
8-A	1	Cylinder drain cock	
4879-A	1	Cylinder fuel pump hole cover plate	
22564-A	1	Cylinder fuel pump hole cover plate gasket	
1048-A	2	Cylinder fuel pump hole cover plate screw	
615-A	2	Cylinder fuel pump hole cover plate lockwasher	

SHIM ASSEMBLY

22274-AS	1	Shim Assembly includes following parts and quantities marked*	
22061-A	12	*Main bearing shim (.002")	
22053-A	12	*Main bearing shim (.003")	
22054-A	24	*Connecting rod shim (.003")	
22067-A	12	*Connecting rod shim (.002")	

CONNECTING ROD

40090-CSY	4	Connecting rod and cap assembly, babbitted and reamed	
(The above includes all bolts, nuts, and shims)			
Takes Place of Part No. 22090-BSY—Plate No. 2.			

NOTE: A suitable allowance will be made for each rod assembly (rod and cap) returned if in condition to be rebabbitted and reused providing our invoice reference is given covering connecting rod which replaced the one returned.

22059-A	8	Connecting rod bolt (Alloy steel— ⁷ / ₁₆ "x20)	Replaces 22055-A
21056-A	8	Connecting rod bolt nut (Chrome steel— ³ / ₁₆ "x20)	2
301-A	8	Connecting rod bolt cotter (³ / ₃₂ "x ³ / ₄ ")	2
22111-A	4	Connecting rod clamp screw (Holds pin) ³ / ₈ "x24x1 ⁹ / ₁₆ "	2
14761-A	4	Connecting rod clamp screw lockwasher	

The piston pin clamp screw was at first locked by means of a lock wire, this lock wire was later replaced by the lockwasher listed above.

22054-A	24	Connecting rod shim (.003") (Brass)	2
22067-A	As Req.	Connecting rod shim (.002") (Brass)	2

PISTON

NOTE: Pistons and rings are supplied in the following oversizes: .005, .010 and .020. On orders for sizes other than specified above, an additional 25 cent will be added to the list price.

The 22215-C Piston has been superseded by piston 22208-C which has four ring grooves while the 22215-C piston has only three ring grooves. The 22215-C piston is listed here for convenience in ordering parts for engines equipped with this three ring type piston. On orders for new pistons the 22208-C piston will be supplied.

22215-CSY	4	Piston with bushings—three ring type. In ordering state if standard or oversize is wanted	
(Takes Place of Part No. 22014-C—Plate No. 2)			
22029-B	4	Piston pin, state if standard or oversize is wanted	2

Give Engine Number with Each Parts Order

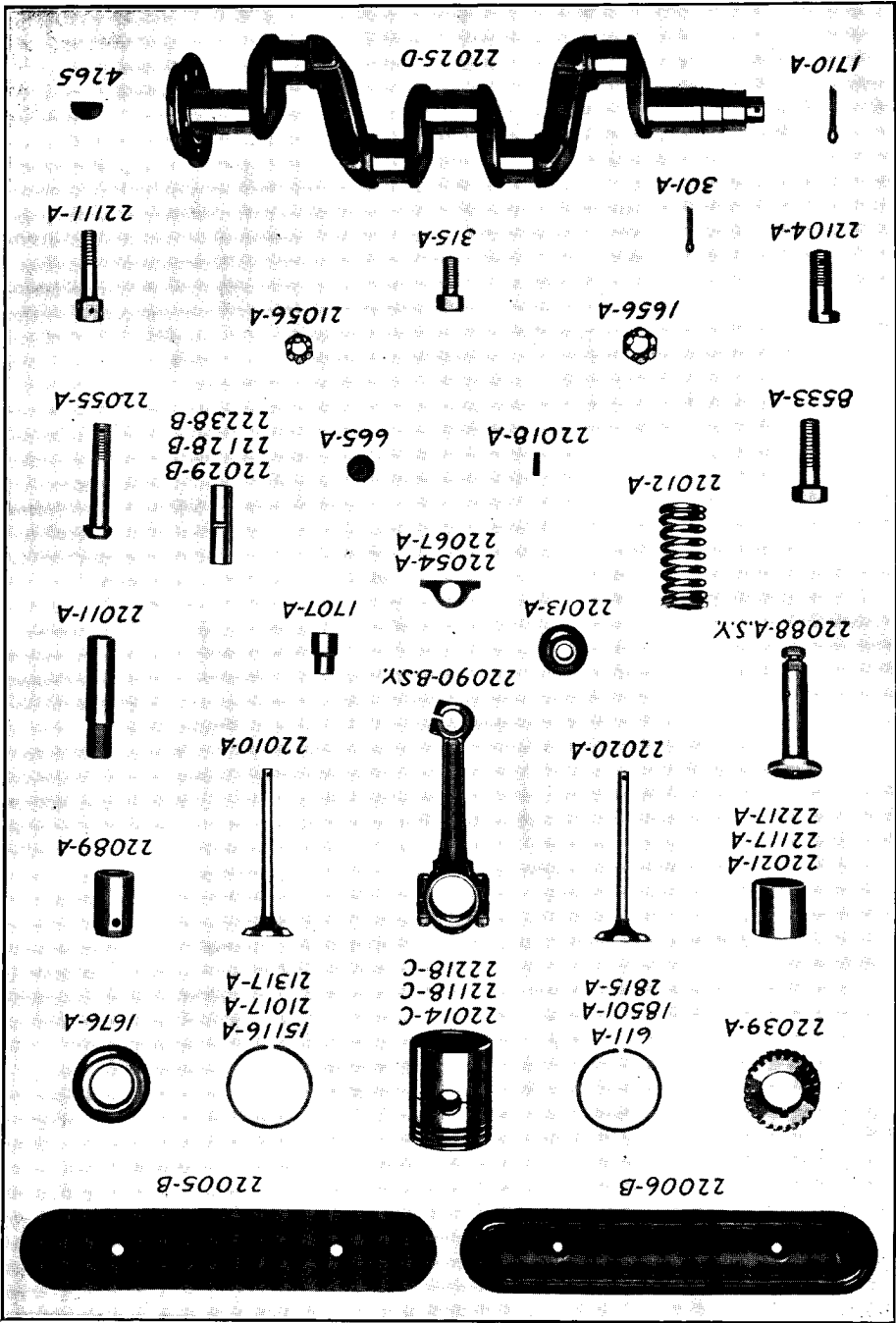

Plate No. 2

Crankshaft, Connecting Rod, Piston, Tappets and Valves

PISTON (Continued)

Part No.	No. Req.	PART NAME	Plate No.
22021-A	8	Piston pin bushing.....	2
611-A	8	Piston ring, compression.....	2
40116-A	4	Piston ring, oil regulating.....	

PISTON (Cast Iron)

See note above about oversizes

■ 22208-CSY	4	Piston with bushings, four ring type.....	
■ 22029-B	4	Piston pin.....	2
22021-A	8	Piston pin bushing.....	2
■ 40117-A	12	Piston ring, compression.....	
■ 40116-A	4	Piston ring, oil regulating.....	

PISTON (Aluminum)

See note above about oversizes

■ 22097-C	4	Piston.....	
■ 40117-A	12	Piston ring, compression.....	
■ 40116-A	4	Piston ring, oil regulating.....	
■ 22029-B	4	Piston pin.....	2

CRANKSHAFT

22025-D	1	Crankshaft.....	2
1676-A	1	Crankshaft oil thrower.....	2
■ 22039-B	1	Crankshaft gear.....	2
4265-A	1	Crankshaft gear key.....	2
22104-A	4	Flywheel bolt ($\frac{1}{16}$ "x1 $\frac{3}{4}$ " long).....	2
1656-A	4	Flywheel bolt nut ($\frac{1}{2}$ "x20).....	2
301-A	4	Flywheel bolt nut cotter ($\frac{1}{8}$ "x1").....	2
1707-A	2	Flywheel dowel ($\frac{1}{2}$ "x $\frac{5}{8}$ ").....	2
665-A	2	Flywheel dowel plug ($\frac{5}{8}$ "expansion).....	2

VALVE

Round valve pin 22018-A was used in valves 22020-A in intake and 22010-A in exhaust on engines having numbers smaller than 226956. On all orders for valves to replace original parts secure oblong lock pin 40011-A. Engines above 226956 have valves 40020-A or 40107-A in intake and 40010-A in exhaust using 40011-A lock pin. Part numbers of valves are forged on the head of the valves.

■ 40107-A	4	Valve, intake.....	
			Takes Place of Part No. 22020-A—Plate No. 2
■ 40010-A	4	Valve, exhaust (Silicrome steel).....	
			Takes Place of Part No. 22010-A—Plate No. 2
■ 22011-A	8	Valve guides.....	
■ 40008-A	8	Valve spring.....	
			Takes Place of Part No. 22012-A—Plate No. 2
22013-A	8	Valve spring seat.....	
22018-A	8	Valve spring seat pin (Round).....	2
■ 40011-A	12	Valve spring seat pin (Oblong).....	
22006-B	1	Valve cover (Steel).....	2
8533-A	2	Valve cover screw ($\frac{1}{2}$ "x13x1 $\frac{1}{2}$ ").....	2
■ 22005-B	1	Valve cover gasket.....	2

PUSH ROD

■ 22088-ASY	8	Push rod assembly (Includes 22088-A, 2185-A, 2186-A).....	2
22088-A	8	Push rod.....	
■ 22089-A	8	Push rod guide.....	2
2185-A	8	Push rod screw (Hardened) ($\frac{3}{8}$ "x24x $\frac{7}{8}$ " long).....	
2186-A	8	Push rod screw nut ($\frac{3}{8}$ "x24).....	

Give Engine Number with Each Parts Order

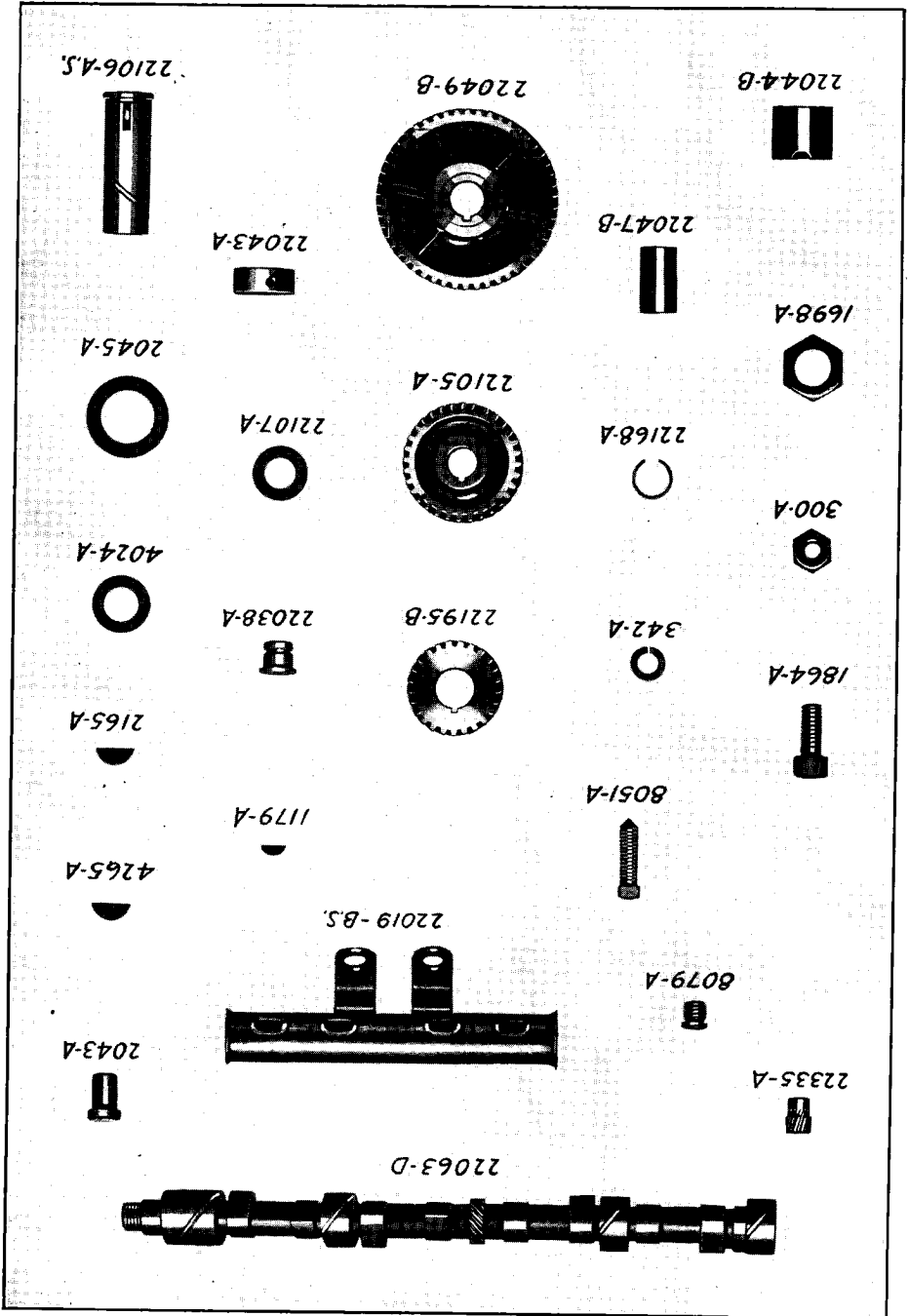

Plate No. 3

Camshaft, Idler Shaft, Gears, and Cable Tube

CYLINDER HEAD

Part No.	No. Req.	PART NAME	Plate No.
22002-D	1	Cylinder head, 4.2:1 compression ratio.....	1
22732-D	1	Cylinder head, 4.2:1 compression ratio—18 m. m. spark plug holes.....	
22736-D	1	Cylinder head, 4.2:1 compression ratio—dual ignition.....	
22737-D	1	Cylinder head, 4.45:1 compression ratio.....	
22742-D	1	Cylinder head, 4.34:1 compression ratio.....	
22751-D	1	Cylinder head, 4.7:1 compression ratio, flat type.....	
22755-D	1	Cylinder head, 5.3:1 compression ratio.....	
22758-D	1	Cylinder head, 5.56:1 compression ratio—natural gas.....	
22759-D	1	Cylinder head, 5.56:1 compression ratio—flat type.....	
22760-D	1	Cylinder head, 4.2:1 compression ratio.....	
■ 22003-C	1	Cylinder head gasket.....	1
1075-A	1	Cylinder head pipe plug, 1/2".....	
4118-A	19	Cylinder head cap screw (1/2"x13x3 1/8" U. S. S.).....	1
■ 87-A	1	Cylinder head outlet pipe gasket (Vellumoid).....	1
315-A	2	Cylinder head outlet pipe screw (3/8"x16x7/8" U. S. S.).....	1
342-A	2	Cylinder head outlet pipe lockwasher (3/8" S. A. E.).....	1

GEAR COVER

22031-D	1	Gear cover.....	1
■ 22024-B	1	Gear cover gasket (Vellumoid).....	1
4680-A	1	Gear cover cork seal (Replaces felt seal).....	
4266-A	8	Gear cover screw (3/8"x16x1 3/4").....	1
342-A	8	Gear cover lock washer (3/8" S. A. E.).....	1
■ 14594-AS	2	Thrust adjusting screw assembly (Idler and water pump).....	
14592-AS	1	Thrust adjusting screw assembly (Camshaft).....	
2048-A	3	Thrust adjusting screw nut.....	1
■ 14591-A	3	Thrust adjusting screw fibre plug.....	

The following parts are used to cover the governor opening in the gear cover when no governor is used:

23412-A	1	Gear cover governor opening cover.....	
■ 10471-A	1	Gear cover governor opening cover gasket.....	
1872-A	2	Gear cover governor opening cover screw.....	
335-A	2	Gear cover governor opening cover screw lockwasher.....	

BREATHER

■ 40038-AS	1	Breather cap assembly (Oil filler cap).....	
		Takes Place of Part No. 22133-AS—Plate No. 1	
27099-A	1	Breather pipe.....	

CAMSHAFT

See note under "Oil Pump Assemblies" and after each camshaft listed below.

22026-DS	1	Camshaft and Plunger Assembly—Cast Alloy Shaft supersedes camshaft 22063-DS. Use Oil Pump Gear 45266-A with this shaft.....	
22063-DS	1	Camshaft and Plunger Assembly—Forged Steel Shaft superseded by 22026-DS. Use Oil Pump Gear 1156-A with this shaft.....	3
22080-B	1	Camshaft front bearing (Phos. bronze).....	3
22081-B	3	Camshaft center and rear bearing (Phos. bronze).....	3
■ 22049-B	1	Camshaft gear.....	3
4265-A	1	Camshaft gear key.....	3
1698-A	1	Camshaft gear nut (1 1/16" x 1 1/16" long).....	3
2045-A	1	Camshaft thrust washer (Celeron).....	3
14209-A	1	Camshaft thrust plunger.....	3
		Takes Place of Part No. 2043-A—Plate No. 3	
14592-AS	1	Camshaft thrust screw assembly.....	
2048-A	1	Camshaft thrust screw nut.....	3
14591-A	1	Camshaft thrust screw fiber plug.....	

Give Engine Number with Each Parts Order

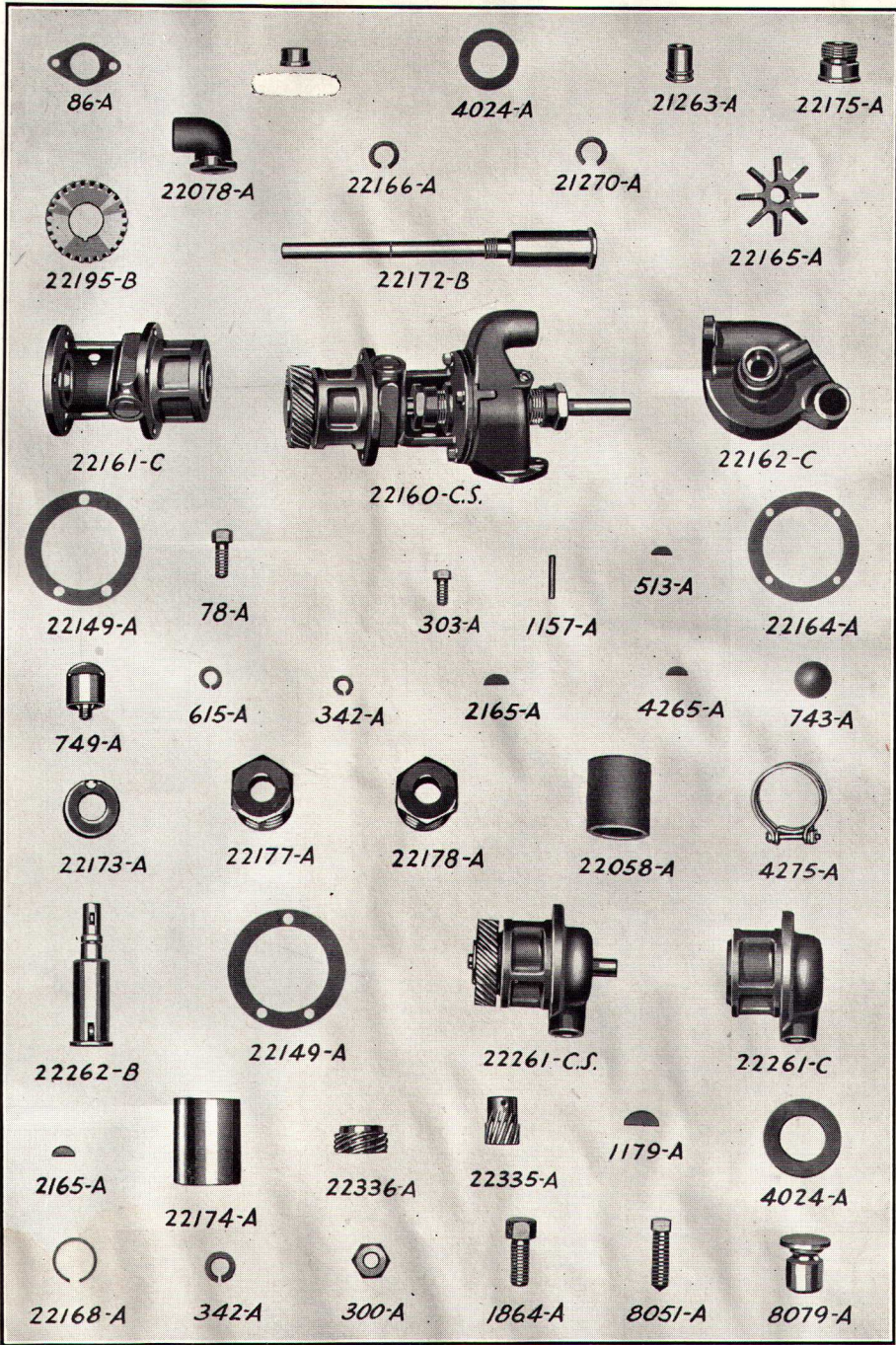

SEE NOTE
BELOW

SEE NOTE
BELOW

Plate No. 4
 Water Pump and Accessory Drive Assembly
**On above plate part No. 22161 should be 22162 and 22162
 should be 22161.**

IDLER GEAR

The following new type idler gear, shaft and bushing has been developed and can be used on all engines of the "OO" series. However, the original undrilled type gear, shaft and bushing can not be used on any engine after number 227680. The new type engine can readily be distinguished from the old type by the absence of an oil metering hole in the plug located at the end of the main oil manifold and back of the idler gear.

Part No.	No. Req.	PART NAME	Plate No.
■ 23305-B	1	Idler gear, drilled for oil holes.....	
23306-A	1	Idler gear shaft, plunger and pipe plug—drilled thru center.....	
59-A	1	Idler shaft pipe plug 1/8".....	
4265-A	1	Idler shaft gear key.....	3
■ 22107-A	1	Idler thrust washer (Celeron).....	3
23307-B	1	Idler shaft bearing drilled for oil hole.....	
14209-A	1	Idler thrust plunger.....	
14594-AS	1	Idler gear thrust adjusting screw assembly.....	
2048-A	1	Idler gear thrust adjusting screw nut.....	3
14591-A	1	Idler gear thrust adjusting screw fiber plug.....	

WATER PUMP

This pump is used when a magneto is required and has no provision for driving distributor. Used on Engines which did not have Filter provision previous to Engine No. 220171, 220173, 220174, 220176 and 220177.

The earlier type pumps had bushings with larger outside diameters than those used later. Both types of bushings are listed below with the outside diameter dimension given after each bushing. Be sure your requirements are known before ordering.

22160-CS	1	Water pump assembly (Including all parts marked*).....	4
22161-CS	1*	Water pump body with bushing.....	4
22165-A	1*	Water pump impeller.....	4
513-A	1*	Water pump impeller key (Woodruff No. 5).....	4
1157-A	1*	Water pump impeller pin (3/16"x1 3/8" long).....	4
22162-CS	1*	Water pump cover with bushings and retainer.....	4
■ 22164-A	1*	Water pump cover gasket.....	4
303-A	4*	Water pump cover screw (3/16"x1 8x3/4" Hex. Hd.).....	4
615-A	4*	Water pump cover screw lockwasher (5/16" S. A. E.).....	4
22172-B	1*	Water pump shaft.....	4
21263-A	1*	Water pump shaft bushing (Bronze and Babbitt) 1 1/16" O. D.....	4
23114-A	1*	Water pump shaft bushing 7/8" O. D.....	
■ 22166-A	1*	Water pump packing (7 ring) front.....	4
■ 21270-A	1*	Water pump packing (5 ring) rear.....	4
22178-A	1*	Water pump packing nut R. H. thread.....	4
22177-A	1*	Water pump packing nut L. H. thread.....	4
21265-A	2*	Water pump packing gland (brass).....	
4265-A	1*	Water pump driving gear key.....	4
22175-A	1*	Water pump packing bushing.....	4
22174-A	1*	Water pump drive bushing 1 13/16" O. D.....	4
22171-B	1*	Water pump drive bushing 1 5/8" O. D.....	
■ 40214-A	1*	Water pump thrust washer (Celeron) (1 1/2"x2 1/2"x1/16").....	4
23116-A	1*	Water pump oil retainer.....	
Takes Place of Part No. 22173-A—Plate No. 4			
■ 22195-B	1*	Water pump drive gear.....	4
2165-A	1*	Water pump shaft key (No. 8 Woodruff).....	4
743-A	1*	Water pump expansion plug (1 1/16" steel).....	4
749-A	1*	Water pump grease cup.....	4
40068-A	1*	Water pump thrust plunger.....	
23115-A	1*	Water pump packing gland (Pressed steel washer).....	
4661-A	1*	Water pump cork washer.....	
1864-A	3	Water pump attaching screw (3/8"x1 6x1").....	4
342-A	3	Water pump attaching lock washer (3/8" S. A. E.).....	4
■ 22149-A	1	Water pump attaching gasket (1/64" Vellumoid).....	4
22078-A	1	Water pump discharge pipe.....	4

Give Engine Number with Each Parts Order

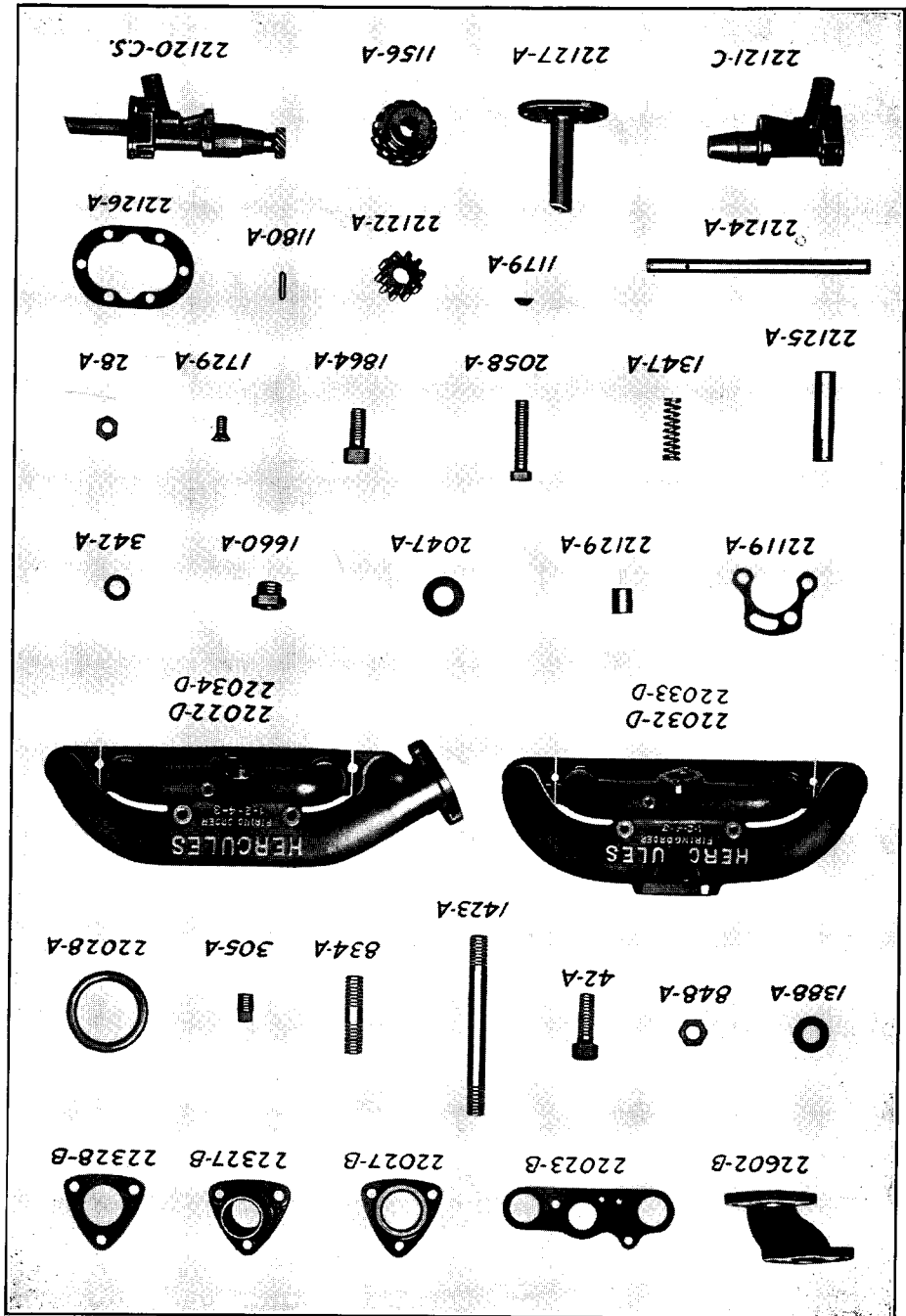

Plate No. 5

Oil Pump, Manifold and Companion Flange

WATER PUMP (Continued)

Part No.	No. Req.	PART NAME	Plate No.
■ 86-A	1	Water pump discharge pipe gasket ($\frac{1}{32}$ " Vellumoid).....	4
78-A	2	Water pump discharge pipe screw ($\frac{5}{16}$ "x18x $\frac{7}{8}$ ").....	4
615-A	2	Water pump discharge pipe lockwashers ($\frac{5}{16}$ " S. A. E.).....	4
■ 22151-A	1	Water pump discharge hose (1 $\frac{3}{8}$ " I. D.x1 $\frac{3}{4}$ " O. D.x1 $\frac{1}{2}$ " long)..... Takes Place of Part No. 22058-A—Plate No. 4	
4275-A	2	Water pump discharge hose clamp (1 $\frac{3}{4}$ " O. D.).....	
14594-AS	1	Water pump thrust adjusting screw assembly.....	
14591-A	1	Water pump thrust adjusting screw fiber plug.....	

WATER PUMP

This pump is used when battery ignition and distributor is required. Used on engines which did not have Filter provision previous to Engine No. 220171, 220173, 220174, 220176 and 220177.

The earlier type pumps had bushings with larger outside diameters than those used later. Both types of bushings are listed below with the outside diameter dimension given after each bushing. Be sure your requirements are known before ordering.

22169-DS	1	Water pump assembly (Includes all parts marked *).....	
22161-CS	1*	Water pump body with bushing.....	4
22165-A	1*	Water pump impeller.....	4
513-A	1*	Water pump impeller key (Woodruff No. 5).....	4
1157-A	1*	Water pump impeller pin ($\frac{3}{16}$ "x1 $\frac{3}{8}$ " long).....	4
22170-CS	1*	Water pump cover with bushing and oil retainer.....	
■ 22164-A	1*	Water pump cover gasket (Vellumoid).....	4
303-A	4*	Water pump cover screw ($\frac{5}{16}$ "x18x $\frac{3}{4}$ " Hex. Hd.).....	4
615-A	4*	Water pump cover screw lockwasher ($\frac{5}{16}$ " S. A. E.).....	4
22172-B	1*	Water pump shaft.....	4
21263-A	1*	Water pump shaft bushing (Bronze and Babbitt) 1 $\frac{1}{16}$ " O. D.....	4
23114-A	1*	Water pump shaft bushing $\frac{7}{8}$ " O. D.....	
■ 22166-A	1*	Water pump packing (7 ring) front.....	4
■ 21270-A	1*	Water pump packing (5 ring) rear.....	4
22178-A	1*	Water pump packing nut R. H. thread.....	4
22177-A	1*	Water pump packing nut L. H. thread.....	4
21265-A	2*	Water pump packing gland (Brass).....	
22175-A	1*	Water pump packing bushing.....	4
22174-A	1*	Water pump drive bushing 1 $\frac{13}{16}$ " O. D.....	4
22171-B	1*	Water pump drive bushing 1 $\frac{5}{8}$ " O. D.....	
4024-A	1*	Water pump thrust washer (Celeron) 1 $\frac{1}{2}$ "x2 $\frac{1}{2}$ x $\frac{1}{16}$ ".....	4
23116-A	1*	Water pump oil retainer..... Takes Place of Part No. 22173-A—Plate No. 4	
22336-A	1*	Water pump distributor driving gear.....	4
1179-A	1*	Water pump distributor driving gear key (Woodruff No. 2).....	4
22168-A	1*	Water pump distributor driving gear lock ring.....	4
749-A	1*	Water pump grease cup.....	4
■ 22195-B	1*	Water pump driving gear.....	4
4265-A	1*	Water pump driving gear key.....	4
40068-A	1*	Water pump thrust plunger.....	
23115-A	1*	Water pump packing gland (Pressed steel washer).....	
4661-A	1*	Water pump cork washer.....	
1864-A	3	Water pump attaching screw ($\frac{3}{8}$ "x16x1").....	4
342-A	3	Water pump attaching lockwasher ($\frac{3}{8}$ " S. A. E.).....	4
■ 22149-A	1	Water pump attaching gasket (Vellumoid $\frac{1}{64}$ ").....	4
22078-A	1	Water pump discharge pipe.....	4
■ 86-A	1	Water pump discharge pipe gasket (Vellumoid).....	4
78-A	2	Water pump discharge pipe screw ($\frac{5}{16}$ "x18x $\frac{7}{8}$ ").....	4
615-A	2	Water pump discharge pipe screw lockwasher ($\frac{5}{16}$ ").....	4
■ 22151-A	1	Water pump discharge hose (1 $\frac{3}{8}$ " I. D.x1 $\frac{3}{4}$ " O. D.x1 $\frac{1}{2}$ " long)..... Takes Place of Part No. 22058-A—Plate No. 4	
4275-A	2	Water pump discharge hose clamp (1 $\frac{3}{4}$ " O. D.).....	4
14594-AS	1	Water pump thrust adjusting screw assembly.....	
14591-A	1	Water pump thrust adjusting screw fiber plug.....	

Give Engine Number with Each Parts Order

Oil Pan, Strainer Assembly and Generator Parts

Plate No. 6

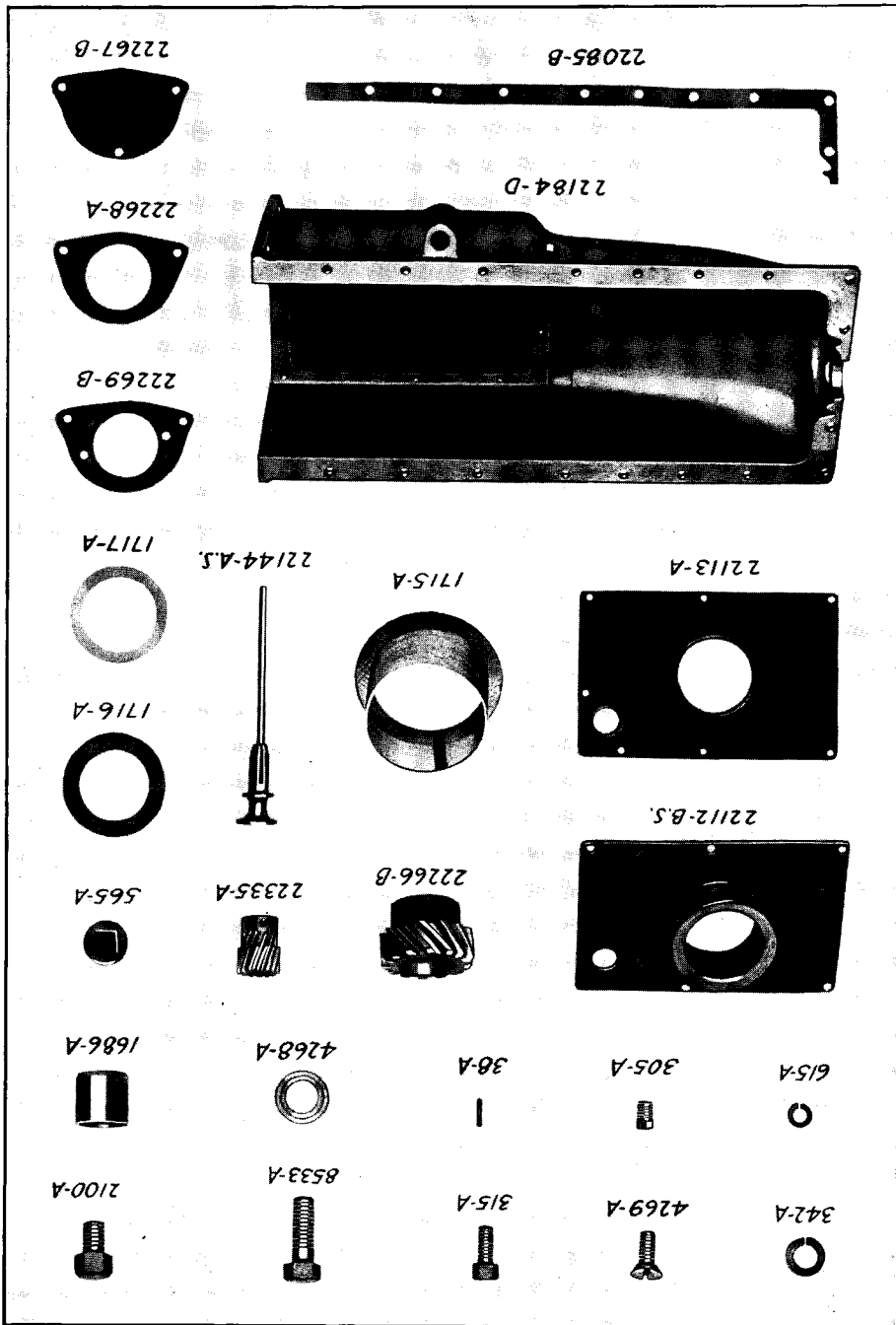

WATER PUMP

This pump is used when a distributor is required. First used on Engines having Oil Filter provision after Engine No. 220177 but was used on Nos. 220172 and 220175.

The earlier type pumps had bushings with larger outside diameters than those used later. Both types of bushings are listed below with the outside diameter dimension given after each bushing. Be sure your requirements are known before ordering.

Part No.	No. Req.	PART NAME	Plate No.
22179-CS	1	Water pump assembly (Includes parts marked *)	
22161-CS	1*	Water pump body with bushing	4
22165-A	1*	Water pump impeller	4
513-A	1*	Water pump impeller key (Woodruff No. 5)	4
1157-A	1*	Water pump impeller pin (3/16" x 1 3/8" long)	4
40171-CS	1*	Water pump cover with bushing and retainer ring	
■ 22164-A	1*	Water pump cover gasket (Vellumoid)	4
303-A	4*	Water pump cover screw (3/16" x 1 8 x 3/4" Hex. Hd.)	4
615-A	4*	Water pump cover lockwasher (3/16" S. A. E.)	4
22180-B	1*	Water pump shaft	
21263-A	1*	Water pump shaft bushing (Bronze and Babbitt) 1 1/16" O. D.	4
23114-A	1*	Water pump shaft bushing 7/8" O. D.	
2165-A	1*	Water pump shaft key (Woodruff No. 8)	4
■ 22166-A	1*	Water pump packing (7 ring) front	4
■ 21270-A	1*	Water pump packing (5 ring) rear	4
22178-A	1*	Water pump packing nut R. H. thread	4
22177-A	1*	Water pump packing nut L. H. thread	4
21265-A	2*	Water pump packing gland (Brass)	
22174-A	1*	Water pump drive bushing (Bronze and Babbitt) 1 13/16" O. D.	
22171-B	1*	Water pump drive bushing 1 3/8" O. D.	
22175-A	1*	Water pump packing bushing	4
4024-A	1*	Water pump thrust washer (1 1/2" x 2 1/2 x 1/16" Celeron)	4
23116-A	1*	Water pump oil retainer	
		Takes Place of Part No. 22173-A—Plate No. 4	
22336-A	1*	Water pump distributor driving gear	4
1179-A	1*	Water pump distributor driving gear key (Woodruff No. 2)	4
22168-A	1*	Water pump distributor driving gear lock ring	4
■ 22195-B	1*	Water pump driving gear	4
4265-A	1*	Water pump driving gear key	4
749-A	1*	Water pump grease cup	4
40068-A	1*	Water pump thrust plunger	
23115-A	1*	Water pump packing gland (Pressed steel washer)	
4661-A	1*	Water pump cork washer	
1864-A	3	Water pump attaching screw (3/8" x 1 6 x 1")	4
■ 22149-A	1	Water pump attaching gasket	4
342-A	3	Water pump attaching screw lockwasher (3/8" S. A. E.)	4
22176-B	1†	Water pump discharge pipe	
■ 22150-A	1	Water pump discharge pipe gasket (1/32" Vellumoid)	
2100-A	3†	Water pump discharge pipe screw (1/2" x 1 3 x 1")	6
352-A	1†	Water pump discharge pipe screw (1/2" x 1 3 x 1 1/4")	
312-A	4†	Water pump discharge pipe screw lockwasher (1/2" S. A. E.)	
■ 22151-A	1	Water pump discharge hose (1 3/8" I. D. 1 3/4" O. D. 1 1/2" long)	
4275-A	1	Water pump discharge hose clamp (1 3/4" O. D.)	4
		(When filter is used eliminate parts marked "†" above)	
14594-AS	1	Water pump thrust adjusting screw assembly	
14591-A	1	Water pump thrust adjusting screw fibre plug	

WATER PUMP

This pump is used when a magneto is required and has no provision for driving distributor. First used on Engines having Oil Filter provision after Engine number 220177 and was used on Engine No. 220172, 220175.

The earlier type pumps had bushings with larger outside diameters than those used later. Both types of bushings are listed below with the outside diameter dimension given after each bushing. Be sure your requirements are known before ordering.

22159-CS	1	Water pump assembly (Includes parts marked *)	
22161-CS	1*	Water pump body with bushing	4

Give Engine Number with Each Parts Order

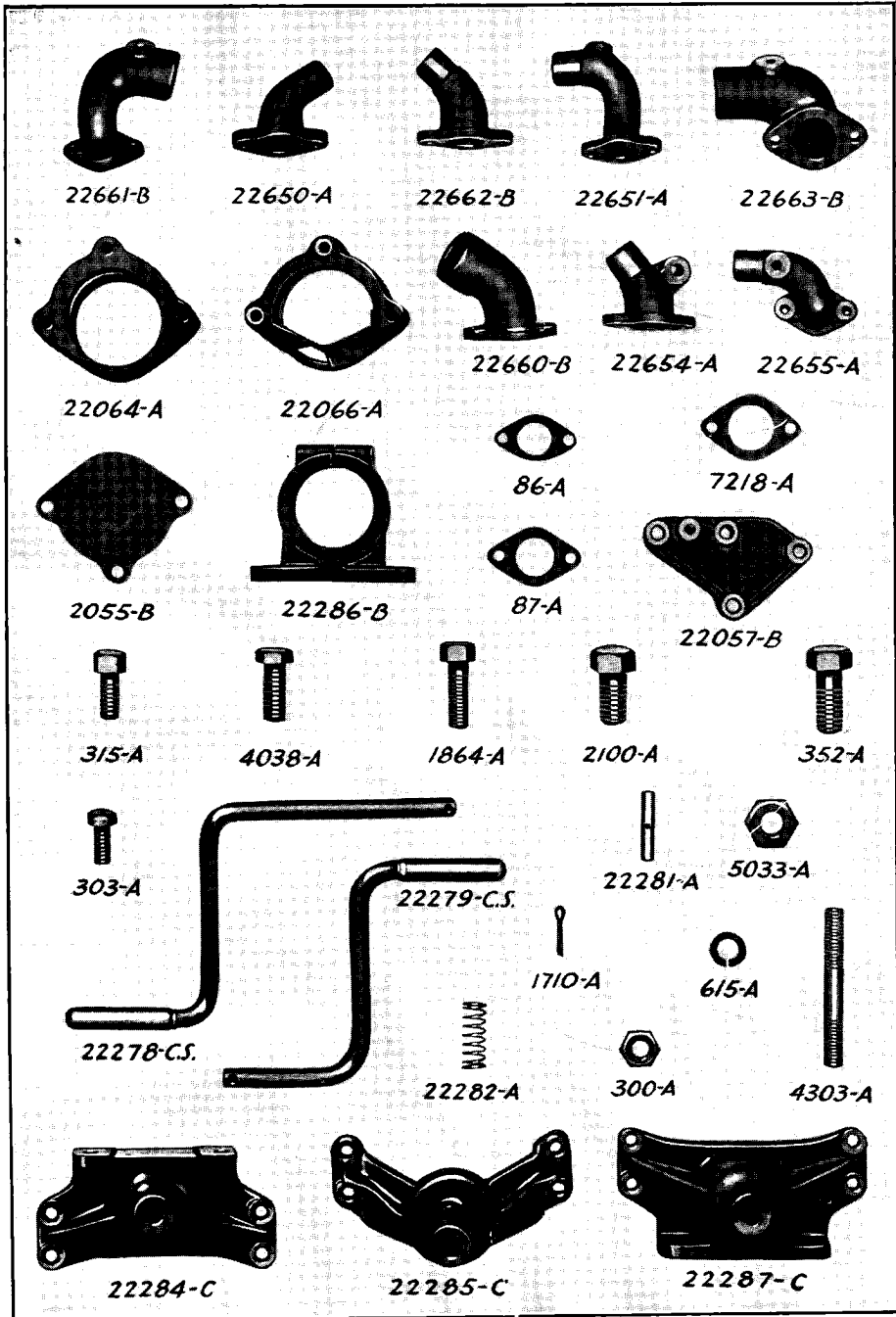

Plate No. 7

WATER PUMP (Continued)

Part No.	No. Req.	PART NAME	Plate No.
22165-A	1*	Water pump impeller.....	4
513-A	1*	Water pump impeller key (Woodruff No. 5).....	4
1157-A	1*	Water pump impeller pin.....	4
22162-CS	1*	Water pump cover with bushing and retainer ring.....	4
303-A	4*	Water pump cover screw (3/16" x 18 x 3/4" Hex. Hd.).....	4
■ 22164-A	1*	Water pump cover gasket (Vellumoid).....	4
615-A	4*	Water pump cover screw lockwasher (5/16" S. A. E.).....	4
22180-B	1*	Water pump shaft.....	
21263-A	1*	Water pump shaft bushing (Bronze and Babbitt) 1 1/16" O. D.....	4
23114-A	1*	Water pump shaft bushing 7/8" O. D.....	
■ 22166-A	1*	Water pump packing (7 ring) front.....	4
■ 21270-A	1*	Water pump packing (5 ring) rear.....	4
22178-A	1*	Water pump packing nut R. H. thread.....	4
22177-A	1*	Water pump packing nut L. H. thread.....	4
21265-A	2*	Water pump packing glands (Brass).....	
749-A	1*	Water pump grease cup.....	4
40068-A	1*	Water pump thrust plunger.....	
23115-A	1*	Water pump packing gland (Pressed steel washer).....	
4661-A	1*	Water pump cork washer.....	
■ 22195-B	1*	Water pump driving gear.....	4
4265-A	1*	Water pump driving gear key.....	4
22175-A	1*	Water pump packing bushing (S. A. E.).....	4
22174-A	1*	Water pump drive bushing (Bronze and Babbitt) 1 13/16" O. D.....	4
22171-B	1*	Water pump drive bushing 1 5/8" O. D.....	
4024-A	1*	Water pump thrust washer (1 1/2" x 2 1/2" x 1/16" fiber).....	4
23116-A	1*	Water pump oil retainer.....	4
Takes Place of Part No. 22173-A—Plate No. 4			
743-A	1*	Water pump expansion plug.....	4
1864-A	3	Water pump attaching screw (3/8" x 16 x 1" long).....	4
342-A	3	Water pump attaching screw lockwasher (3/8" S. A. E.).....	4
■ 22149-A	1	Water pump attaching gasket (Vellumoid).....	4
22176-B	1	Water pump discharge pipe.....	
■ 22150-A	1	Water pump discharge pipe gasket (Vellumoid).....	
2100-A	3	Water pump discharge pipe screw (1/2" x 13 x 1").....	6
352-A	1	Water pump discharge pipe screw (1/2" x 13 x 1 1/4").....	
312-A	4	Water pump discharge pipe screw lockwasher (1/2" S. A. E.).....	
■ 22151-A	1	Water pump discharge pipe hose.....	
4275-A	2	Water pump discharge pipe hose clamp.....	4
14594-AS	1	Water pump thrust adjusting screw assembly.....	
14591-A	1	Water pump thrust adjusting screw fiber plug.....	

WATER PUMP

This water pump assembly has a short shaft and is a blind end pump used only with a distributor and no magneto.

23117-CS	1	Water pump assembly (Includes parts marked *).....	
40171-CS	1	*Water pump cover with bushing.....	
4024-A	1	*Water pump thrust washer.....	
■ 22164-A	1	*Water pump cover gasket.....	
303-A	4	*Water pump cover screw.....	
615-A	4	*Water pump cover lockwasher.....	
22161-CS	1	*Water pump body with bushing.....	
22165-A	1	*Water pump impeller.....	
513-A	1	*Water pump impeller key.....	
1157-A	1	*Water pump impeller pin.....	
22177-A	1	*Water pump packing nut L. H.....	
22178-A	1	*Water pump packing nut R. H.....	
21265-A	2	*Water pump packing gland.....	
22175-A	1	*Water pump packing bushing.....	
■ 22166-A	1	*Water pump packing (7 ring type).....	
■ 22195-B	1	*Water pump driving gear.....	
4265-A	1	*Water pump driving gear key.....	

Give Engine Number with Each Parts Order

Bellhousings, Flywheel, Clutch and Fans

Plate No. 8

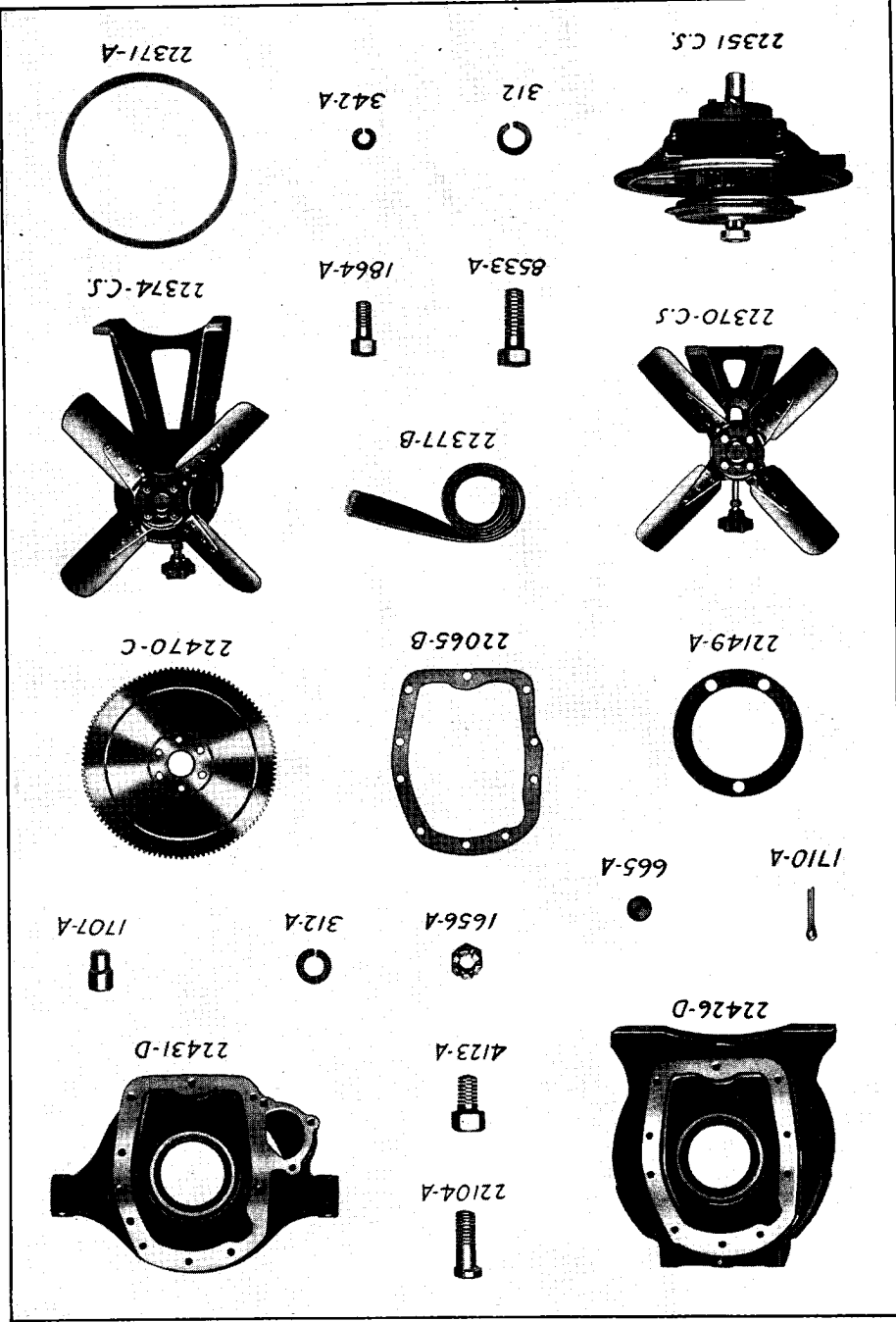

WATER PUMP (Continued)

Part No.	No. Req.	PART NAME	Plate No.
22171-B	1	*Water pump drive bushing.....	
23119-B	1	*Water pump shaft.....	
23114-A	1	*Water pump shaft bushing.....	
23120-A	1	*Water pump lead seal.....	
4661-A	1	*Water pump cork washer.....	
23116-A	1	*Water pump oil retainer.....	
22336-A	1	*Water pump distributor driven gear.....	
22168-A	1	*Water pump distributor driven gear snap ring.....	
1179-A	1	*Water pump distributor driven gear key.....	
749-A	1	*Water pump grease cup.....	
40068-A	1	*Water pump thrust washer.....	
1864-A	3	Water pump attaching screw.....	
342-A	3	Water pump attaching lock washer.....	
■ 22149-A	1	Water pump attaching gasket.....	
22176-B	1	Water pump discharge pipe.....	
■ 22150-A	1	Water pump discharge pipe gasket.....	
2100-A	3	Water pump discharge pipe screw.....	
352-A	1	Water pump discharge pipe screw.....	
312-A	4	Water pump discharge pipe lock washer.....	
■ 22151-A	1	Water pump discharge hose.....	
4275-A	2	Water pump discharge hose clamp.....	
14594-AS	1	Water pump thrust adjusting screw assembly.....	
14591-A	1	Water pump thrust adjusting screw fiber plug.....	

ACCESSORY DRIVE (Thermo Syphon)

NOTE: This Accessory Drive is used with a Distributor and eliminates all Water Pump parts.

22261-CS	1	Accessory drive assembly (Includes all parts marked *).....	4
22261-C	1*	Accessory drive housing.....	4
22262-B	1*	Accessory drive shaft.....	4
22168-A	1*	Accessory drive snap ring.....	4
22336-A	1*	Distributor driving gear.....	4
22335-A	1*	Distributor driven gear.....	4
1179-A	1*	Distributor gear key (No. 2 Woodruff).....	4
2165-A	1*	Accessory drive shaft key (No. 8 Woodruff).....	4
22174-A	1*	Accessory drive bushing.....	4
22173-A	1*	Accessory drive oil ring.....	4
■ 22195-B	1*	Accessory drive gear.....	4
4265-A	1*	Accessory drive gear key (No. 91 Woodruff).....	4
4024-A	1*	Accessory drive thrust washer (Celeron 1 ¹ / ₂ " x 2 ¹ / ₂ " x 1 ¹ / ₁₆ ").....	4
2043-A	1*	Accessory drive thrust plunger.....	3
4661-A	1*	Accessory drive cork washer.....	
■ 22149-A	1	Accessory drive attaching gasket (Vellumoid 1 ¹ / ₆₄ ").....	4
1864-A	3	Accessory drive attaching screw (3 ³ / ₈ " x 16 x 1").....	4
342-A	3	Accessory drive attaching screw lockwasher (3 ³ / ₈ " S. A. E.).....	4
NOTE: When Distributor is not used, use the following parts.			
8079-A	1	Distributor plug.....	4
8051-A	1	Distributor plug screw (3 ³ / ₈ " x 16 x 1 ¹ / ₈ ").....	4
300-A	1	Distributor plug lock nut (3 ³ / ₈ " x 16).....	4

ACCESSORY DRIVE (Thermo Syphon)

NOTE: This Accessory Drive is used without a distributor and eliminates all Water Pump parts.

22260-BS	1	Accessory drive assembly (Includes all parts marked *).....	
22264-C	1*	Accessory drive housing.....	
22262-B	1*	Accessory drive shaft.....	4
2165-A	1*	Accessory drive shaft (Woodruff No. 8).....	4
22174-A	1*	Accessory drive bushing.....	4
22173-A	1*	Accessory drive oil ring.....	4

Give Engine Number with Each Parts Order

Governor and Valve Box Parts

Plate No.

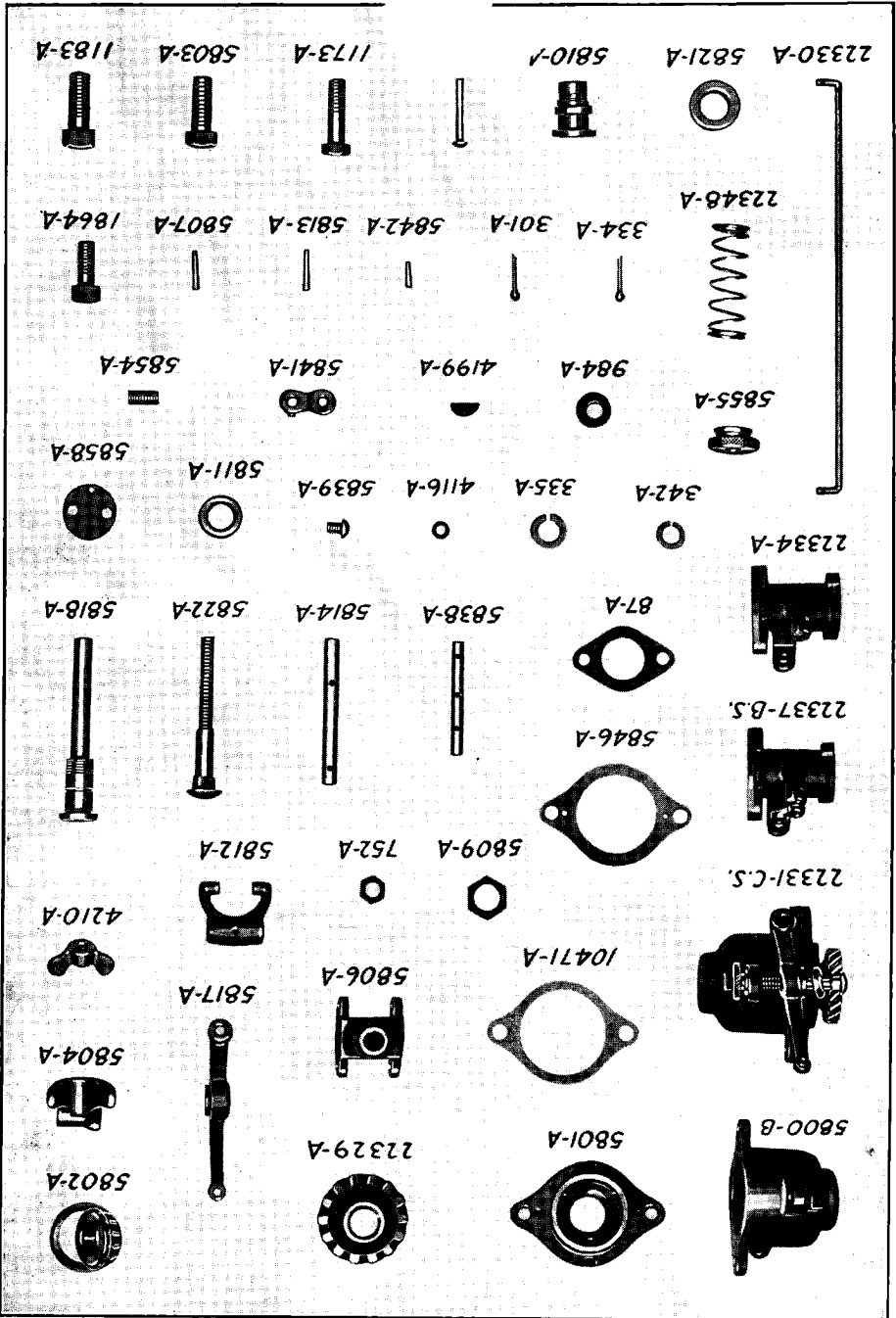

ACCESSORY DRIVE (Thermo Syphon) (Continued)

Part No.	No. Req.	PART NAME	Plate No.
■ 22195-B	1*	Accessory drive gear.....	4
4265-A	1*	Accessory drive gear key (No. 91 Woodruff).....	4
4024-A	1*	Accessory drive thrust washer (1 $\frac{1}{2}$ "x2 $\frac{1}{2}$ "x $\frac{1}{16}$ " Celeron).....	4
2043-A	1*	Accessory drive thrust plunger.....	3
4661-A	1*	Accessory drive cork washer.....	
743-A	1*	Accessory drive expansion plug.....	
■ 22149-A	1	Accessory drive attaching gasket ($\frac{1}{64}$ " Vellumoid).....	4
1864-A	3	Accessory drive attaching screw ($\frac{3}{8}$ "x1 $\frac{1}{2}$ "x $\frac{1}{16}$ " S. A. E.).....	4
342-A	3	Accessory drive attaching screw lockwasher ($\frac{3}{8}$ " S. A. E.).....	4

FAN DRIVE PARTS

22072-B	1	Fan pulley—Standard.....	
		Takes Place of Part No. 22076-B—Plate No. 1	
22071-A	1	Fan pulley pin.....	
		Takes Place of Part No. 22074-A—Plate No. 1	
301-A	2	Fan pulley pin cotter.....	1
4265-A	1	Fan pulley key.....	1
22283-A	1	Starting crank grab (Used when no fan pulley is used).....	1

FAN ASSEMBLIES

There is such a wide variety of fan assemblies used it is impossible to list all of them in a book of this size; some of the more common are listed below. Many manufacturers using these models of engines supply their own fan assemblies which the Hercules Motors Corporation do not usually service. When ordering please give all available dimensions and part numbers; also give engine numbers.

22370-CS	1	Fan assembly, 18" dia. blade, "V" pulley—bracket 5 $\frac{13}{16}$ " high.....	8
22382-CS	1	Fan assembly, 18" dia. blade, "V" pulley—bracket 7 $\frac{13}{16}$ " high.....	
22385-CS	1	Fan assembly, 18" dia. blade, "V" pulley—bracket 4 $\frac{7}{16}$ " high, adjusting screw on top of bracket.....	
22404-CS	1	Fan assembly, 18" dia. blade, "V" pulley—bracket 4 $\frac{7}{16}$ " high and closed across top.....	
22407-CS	1	Fan assembly, 18" dia. blade, "V" pulley—bracket 4 $\frac{7}{16}$ " high and open at top. This fan assembly superseded by 23281-CS.....	
23262-CS	1	Fan assembly, 20" dia. blade, "V" pulley—bracket 8 $\frac{13}{16}$ " high.....	
23276-CS	1	Fan assembly, 13 $\frac{1}{2}$ " dia., 6 blade, "V" pulley—bracket 2 $\frac{3}{16}$ " high.....	
23281-CS	1	Fan assembly, 18" dia. blade, "V" pulley—bracket 4 $\frac{7}{16}$ " high.....	
8533-A	2	Fan attaching screw ($\frac{1}{2}$ "x1 $\frac{1}{2}$ "x $\frac{1}{16}$ " S. A. E.).....	
312-A	2	Fan attaching screw lock washer.....	

FAN BELTS

22371-A	1	Fan belt, "V" type, 40" outside circumference.....	8
22383-B	1	Fan belt, "V" type, 44" outside circumference.....	
22386-B	1	Fan belt, "V" type, 37 $\frac{3}{8}$ " outside circumference.....	16
23270-B	1	Fan belt, "V" type, 33 $\frac{3}{16}$ " outside circumference.....	

FLYWHEELS

Part numbers on flywheels are stamped on the rims. If the flywheel is ordered be sure to give part number of flywheel and engine number of engine for which the wheel is ordered as there is such a large variety of flywheels used it would be impossible to list all in a book of this size. Some of the more common are listed below.

22470-C	1	Flywheel No. 4 Twin Disc C-8 (205 PB bearing).....	8
22471-C	1	Flywheel No. 5 Twin Disc C-8 (205 PB bearing).....	
22472-C	1	Flywheel No. 4 Twin Disc C-8 (205 PB bearing).....	
23497-C	1	Flywheel No. 4 Twin Disc C-10 GT.....	
22474-C	1	Flywheel No. 4 Twin Disc C-8.....	
22475-C	1	Flywheel No. 5 (205 PB bearing).....	

Give Engine Number with Each Parts Order

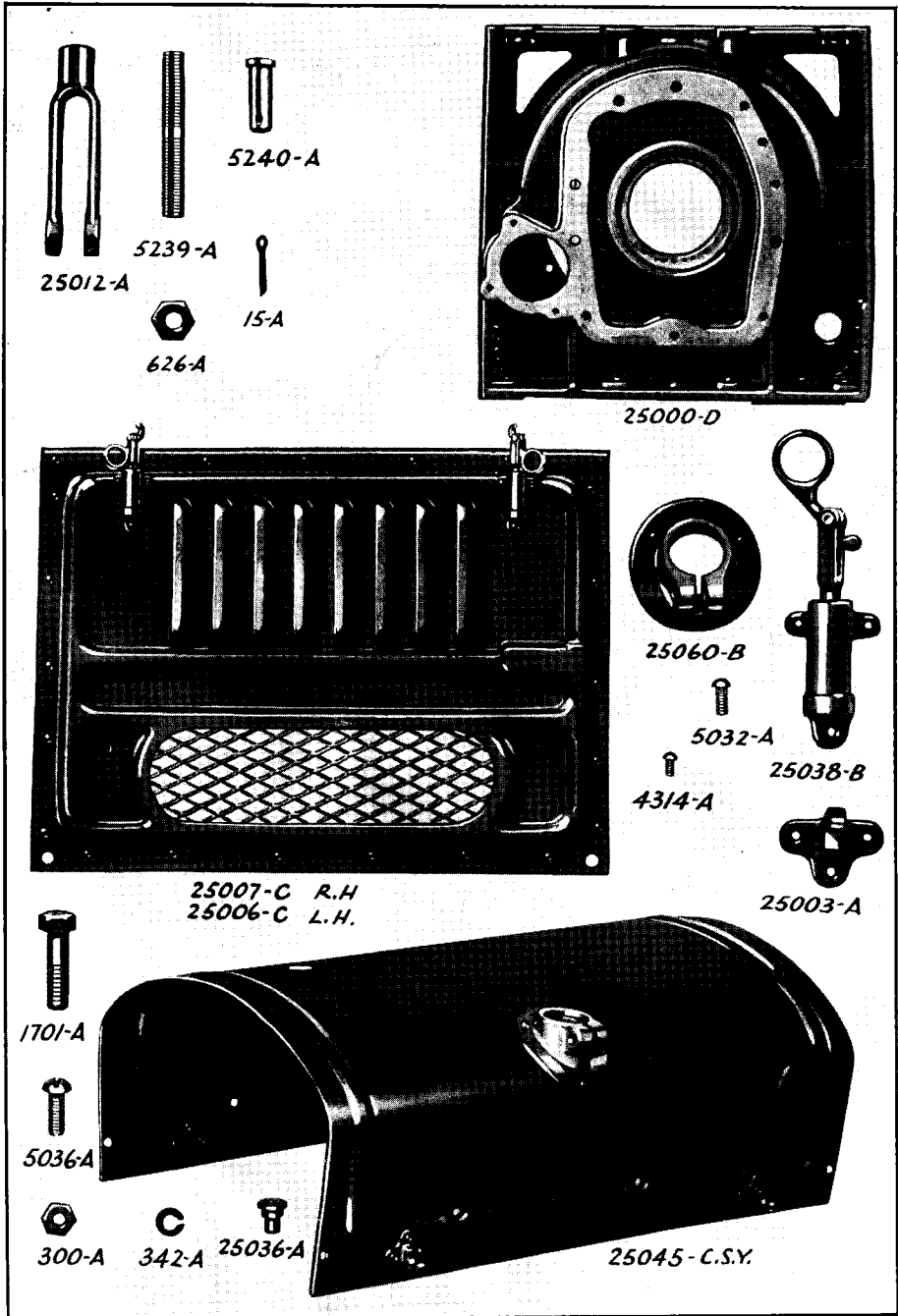

Plate No. 10

Power Unit Hood, Side Panels and Bellhousing

FLYWHEELS (Continued)

Part No.	No. Req.	PART NAME	Plate No.
22476-C	1	Flywheel No. 4 S. A. E.....	
23510-C	1	Flywheel No. 4.....	
23715-C	1	Flywheel No. 5.....	
22480-C	1	Flywheel No. 3.....	
22481-C	1	Flywheel No. 4 12" R. G. Y. Borg and Beck.....	
22537-C	1	Flywheel No. 4 C-10 Twin Disc.....	
22521-C	1	Flywheel No. 4—Borg and Beck 11A1.....	
23514-C	1	Flywheel No. 4—11CF—C1—Long.....	
22486-C	1	Flywheel No. 4—9-AB Long.....	
22485-C	1	Flywheel No. 4—C-8 Twin Disc.....	
22487-C	1	Flywheel No. 4—12SP Brown Lipe.....	
22496-C	1	Flywheel No. 4 S. A. E. C-10 Twin Disc.....	
22514-C	1	Flywheel No. 4 S. A. E. 11 QLD Borg and Beck.....	
22524-C	1	Flywheel No. 4 C-8 Twin Disc.....	
22531-C	1	Flywheel 29-A Long.....	
23473-C	1	Flywheel No. 4 10A-1 Borg and Beck.....	
23508-C	1	Flywheel No. 5 Twin Disc C-8.....	
22104-A	4	Flywheel bolt (1/2"x20x1 11/32") (Std.).....	8
1656-A	4	Flywheel bolt nut (1/2"x20").....	8
301-A	4	Flywheel bolt nut cotter (1/8"x1").....	8
1707-A	2	Flywheel dowel (1/2"x5/8").....	8
665-A	2	Flywheel dowel plug (5/8").....	8
22345-A	4	Flywheel bolt (1/2"x20x1 7/8") (Special).....	
2164-A	2	Flywheel dowel (Special).....	
22488-C	1	Ring gear, 110 teeth.....	
22505-C	1	Ring gear, 112 teeth.....	
22532-C	1	Ring gear, 115 teeth.....	
23471-C	1	Ring gear, 97 teeth.....	

**BELLHOUSING
(Or Flywheel Housing)**

As there are many special bell housings, it is advisable to give engine number when ordering.

22424-D	1	Bellhousing No. 4 (Combine) leg type.....	
22425-D	1	Bellhousing No. 5 (Combine) leg type.....	
22426-D	1	Bellhousing No. 4 leg type.....	8
22427-D	1	Bellhousing No. 3 leg type.....	
22429-D	1	Bellhousing No. 4 S. A. E. with starter.....	
23445-D	1	Bellhousing No. 5 leg type.....	
25029-D	1	Bellhousing No. 4 S. A. E. Power unit type.....	
25340-D	1	Bellhousing No. 4 S. A. E. Power unit type.....	8
22435-D	1	Bellhousing No. 4 S. A. E.....	
22445-D	1	Bellhousing special plate type.....	
22463-D	1	Bellhousing No. 4.....	
23425-D	1	Bellhousing No. 4 S. A. E.....	
23427-D	1	Bellhousing No. 4 special steel.....	
23428-D	1	Bellhousing No. 5 S. A. E. leg type.....	
25000-D	1	Bellhousing No. 4 S. A. E. power unit type.....	
25114-D	1	Bellhousing No. 4 S. A. E.....	
22065-B	1	Bellhousing gasket (1/32" Vellumoid).....	8
4123-A	5	Bellhousing to crankcase screw (1/2"x13x7/8" Hex. Hd.).....	8
4625-A	2	Bellhousing screw (1/2"x13x1 1/4").....	
2100-A	4	Bellhousing screw (1/2"x13x1").....	7
312-A	11	Bellhousing to crankcase screw lockwasher (1/2" S. A. E.).....	8
18421-D	1	Bellhousing timing hole cover plate.....	
1048-A	2	Bellhousing timing hole cover plate screw.....	
615-A	2	Bellhousing timing hole cover plate screw lockwasher.....	

OIL PAN

22184-D	1	Oil pan.....	6
22085-B	2	Oil pan gasket (Vellumoid).....	6

Give Engine Number with Each Parts Order

Instrument Panels, Gauges and Pipes

Plate No. 11

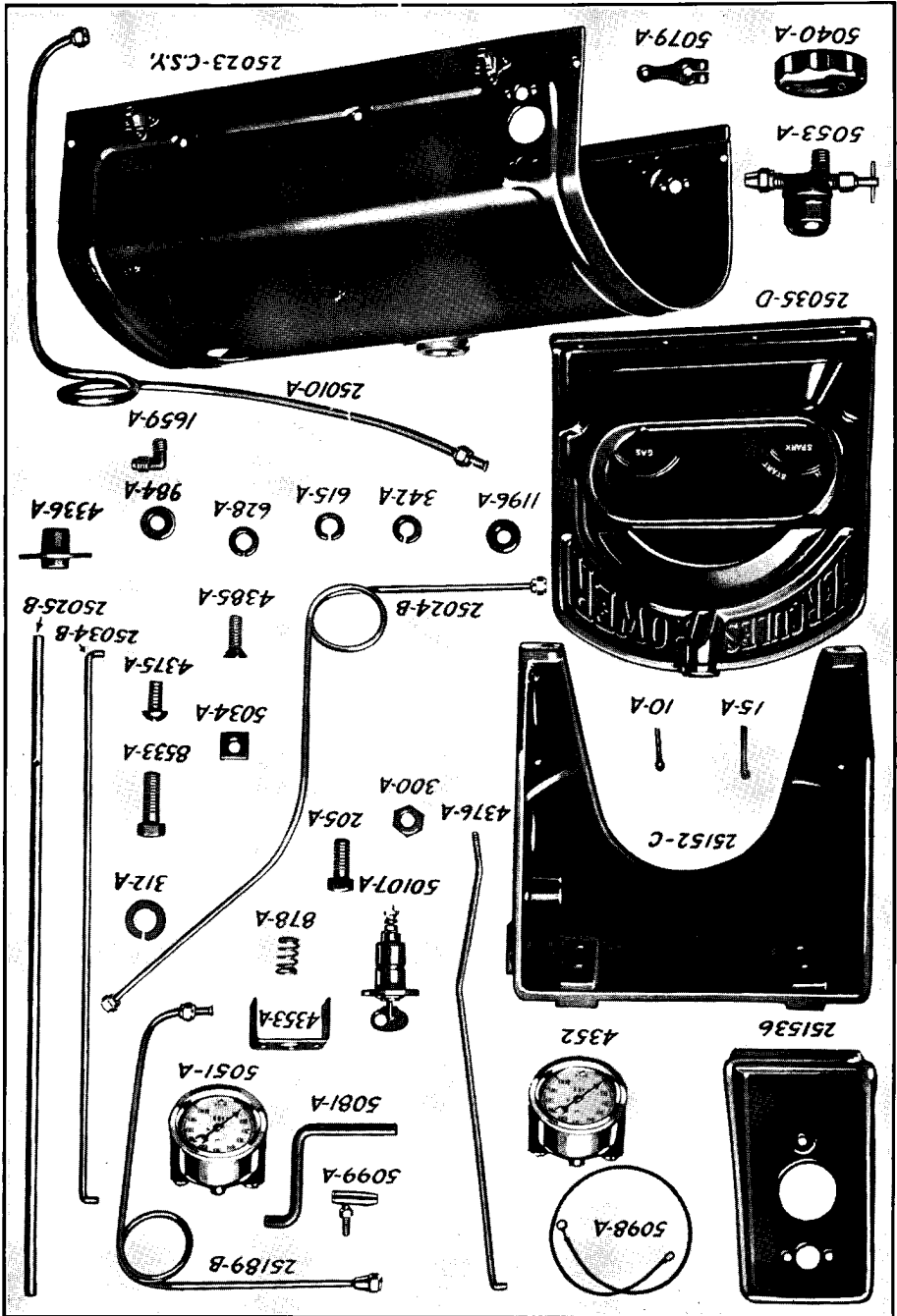

OIL PAN (Continued)

Part No.	No. Req.	PART NAME	Plate No.
315-A	18	Oil pan screw (3/8"x16x7/8")	6
342-A	18	Oil pan screw lock washer (3/8" S. A. E.)	6
22110-B	1	Oil pan strainer assembly (Includes parts marked *)	
45188-A	1*	Oil pan strainer screen	
22113-A	1*	Oil pan baffle plate	6
565-A	2	Oil pan oil strainer pipe plug (3/4"x14)	6
22144-AS	1	Oil pan bayonet gauge with knob	6
303-A	7	Oil pan baffle plate screw (5/16"x18x3/4")	4
615-A	7	Oil pan baffle plate lockwasher (5/16" S. A. E.)	6
4679-A	1	Oil pan felt	
<p>For Oil Pans equipped with oil strainer assembly similar to 22112-B shown in Plate No. 6. The following felt ring must be ordered for service. When the complete assembly is required order 22110-B listed above.</p>			
1716-A	1	Oil pan strainer felt washer	6

OIL PUMP ASSEMBLIES

There are two types of oil pumps with regard to pumping gears, one has 3/4" wide gears. This is Oil Pump Assembly 22115-CS. The first oil pump to use 1 1/4" wide gears was 22152-CS having hardened top end drive gear 1156-A (used with forged camshaft). Later assemblies are similar to 22152-CS with exception of the top end drive gear. Before ordering parts read notes under "Camshaft" and each oil pump assembly.

The hard steel driving gear 1156-A is used on all engines before engine number 234605 and unless the camshaft is being replaced should be ordered either separately or with oil pump assembly 22152-CS. This gear and pump assembly is used with the forged steel camshaft 22063-DS.

Oil Pump Assembly 23152-CS with gear drive 45266-A was first used on engine number 234605 and all engines up to the time this book goes to press.

In replacing camshaft in engines before engine number 234605 the 45266-A oil pump drive gear must be ordered with the camshaft as the 1156-A drive gear does not work well with the cast alloy camshaft.

In an emergency any combination of the above may be used.

OIL PUMP

The 22115-CS Oil Pump Assembly has 3/4" gears while the 22152-CS oil pump assembly has 1 1/4" gears. The 22152-CS Oil Pump Assembly replaces the 22115-CS Oil Pump Assembly as an assembly only. The 22115-CS Oil Pump Assembly is listed below to assist in ordering parts for this pump. On orders for complete pump assemblies, the 22152-CS oil pump assembly will be supplied.

22115-CS	1	Oil pump assembly (Includes all parts marked *)	
22116-C	1*	Oil pump body	
22127-A	1*	Oil pump cover	5
4387-A	2*	Oil pump snap ring	
1729-A	6*	Oil pump cover screw (14x20x5/8") flat. hd.	5
22122-A	2*	Oil pump gears, 3/4" long	5
22124-A	1*	Oil pump shaft	5
1156-A	1*	Oil pump drive gear	5
2047-A	1*	Oil pump drive gear washer (Celeron)	5
1181-A	1*	Oil pump drive gear pin	
<p>Takes Place of Part No. 1180-A—Plate No. 5</p>			
1179-A	2*	Oil pump gear key (No. 2 Woodruff)	5
22125-A	1*	Oil pump idler shaft	5
22119-A	1	Oil pump body attaching gasket (Vellumoid)	5
1864-A	3	Oil pump body screw (3/8"x16x1")	5
342-A	3	Oil pump body screw lockwasher (3/8" S. A. E.)	5
2058-A	1*	Oil pump pressure regulating screw (5/16"x24x1 3/4" S. A. E.)	5
28-A	1*	Oil pump pressure regulating nut (Fits 2058) (5/16"x24 S. A. E.)	5
1660-A	1*	Oil pump pressure regulator nut	5
1347-A	1*	Oil pump pressure regulator spring	5
22129-A	1*	Oil pump pressure regulator piston	5
1385-A	1*	Oil pump pressure regulator fitting	

Give Engine Number with Each Parts Order

Radiator and Shell, Hose and Water Pipes

Plate No. 12

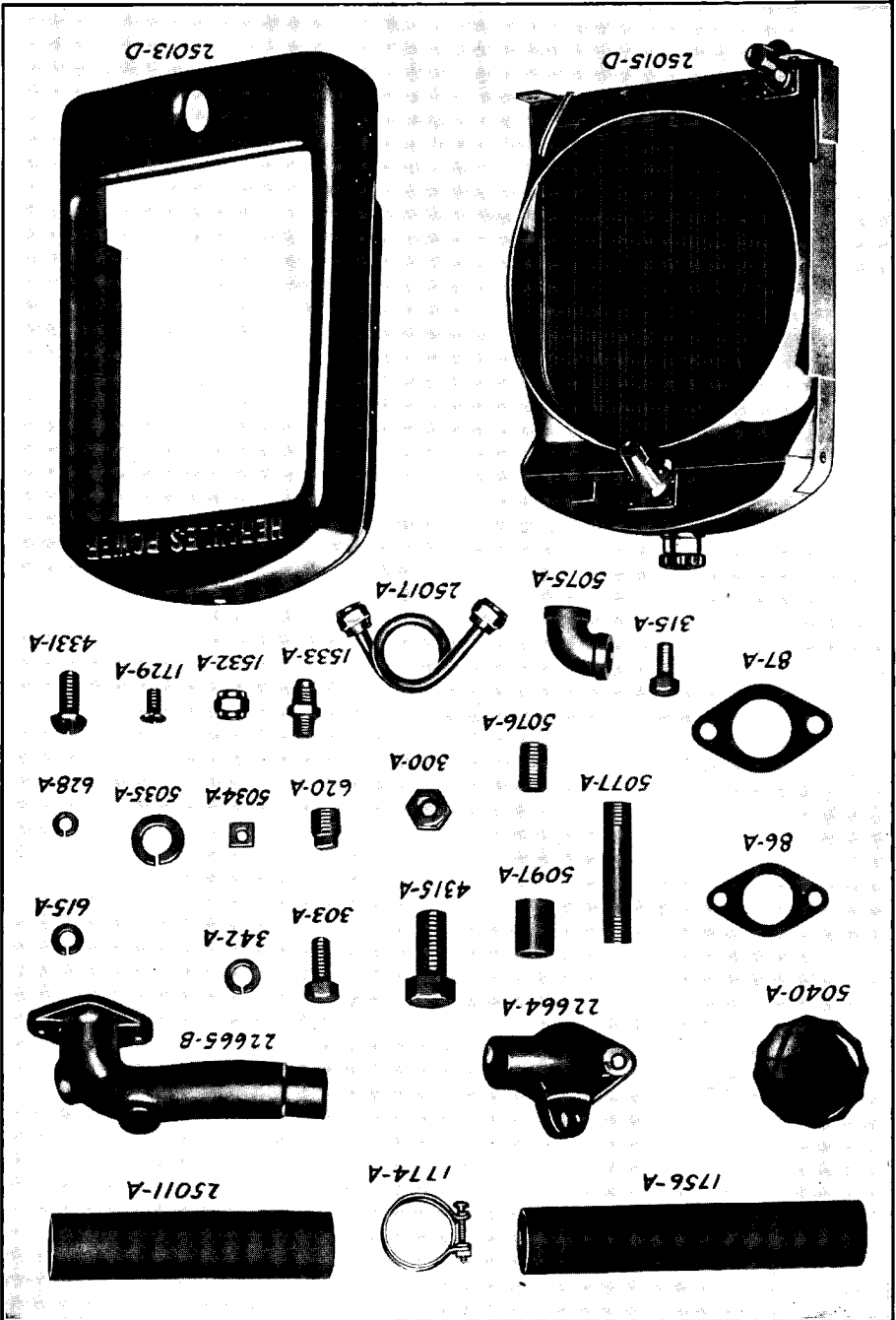

OIL PUMP

The 22152-C Oil Pump Assembly replaces the 22115-CS Oil Pump Assembly.

This oil pump has the hardened steel drive gear and must be used with the forged steel camshaft 22063-D.

Part No.	No. Req.	PART NAME	Plate No.
22152-CS	1	Oil pump assembly (Includes parts marked *)	
22153-C	1*	Oil pump body	
22127-C	1*	Oil pump cover	
1729-A	6*	Oil pump cover screw	5
4387-A	2*	Oil pump snap ring	
22154-A	2*	Oil pump gears, 1 ¹ / ₄ " long	
22124-A	1*	Oil pump shaft	5
1156-A	1*	Oil pump drive gear	5
2047-A	1*	Oil pump drive gear washer	5
1181-A	1*	Oil pump drive gear pin	
1179-A	2*	Oil pump gear key	5
22155-A	1*	Oil pump idler shaft	
2058-A	1*	Oil pump pressure regulator screw	5
28-A	1*	Oil pump pressure regulator screw nut	5
1660-A	1*	Oil pump pressure regulator nut	5
1347-A	1*	Oil pump pressure regulator spring	5
1385-A	1*	Oil pump pressure regulator fitting	
22129-A	1*	Oil pump pressure regulator piston	5
22119-A	1	Oil pump body attaching gasket	5
1864-A	3	Oil pump body attaching screw (3 ³ / ₈ " x 16 x 1")	5
342-A	3	Oil pump body attaching screw lock washer (3 ³ / ₈ " S. A. E.)	5

**OIL PUMP
(STANDARD)**

This pump supersedes pump 22152-CS and has a cast alloy drive gear. Use this pump with camshaft 22026-D which is a cast alloy shaft.

23152-CS	1	Oil pump assembly (Includes parts marked *)	
22153-C	1	*Oil pump body	
22127-A	1	*Oil pump cover	
1729-A	6	*Oil pump cover screw	
4387-A	2	*Oil pump snap ring	
22154-A	2	*Oil pump gears	
22124-A	1	*Oil pump shaft	
45266-A	1	*Oil pump drive gear	
2047-A	1	*Oil pump drive gear washer	
4809-A	1	*Oil pump drive gear pin	
1179-A	2	*Oil pump gear key	
22155-A	1	*Oil pump idler shaft	
2058-A	1	*Oil pump pressure regulator screw	
28-A	1	*Oil pump pressure regulator screw nut	
1660-A	1	*Oil pump pressure regulator nut	
1347-A	1	*Oil pump pressure regulator spring	
22129-A	1	*Oil pump pressure regulator piston	
1385-A	1	*Oil pump pressure regulator fitting	
22119-A	1	*Oil pump body attaching gasket	
1864-A	3	Oil pump body attaching screw	
342-A	3	Oil pump body attaching screw lock washer	

MANIFOLD

If the manifold on engine does not appear in this list send a sketch or description of manifold wanted and engine number of engine for which manifold is wanted. With the large variety of manifolds in use it is impossible to list them in a book of this size.

22032-D	1	Exhaust and intake manifold (Center outlet 1 ¹ / ₄ ")	5
22033-D	1	Exhaust and intake manifold (Center outlet 1")	5
22022-D	1	Exhaust and intake manifold (Rear outlet) 1 ¹ / ₄ "	5

Give Engine Number with Each Parts Order

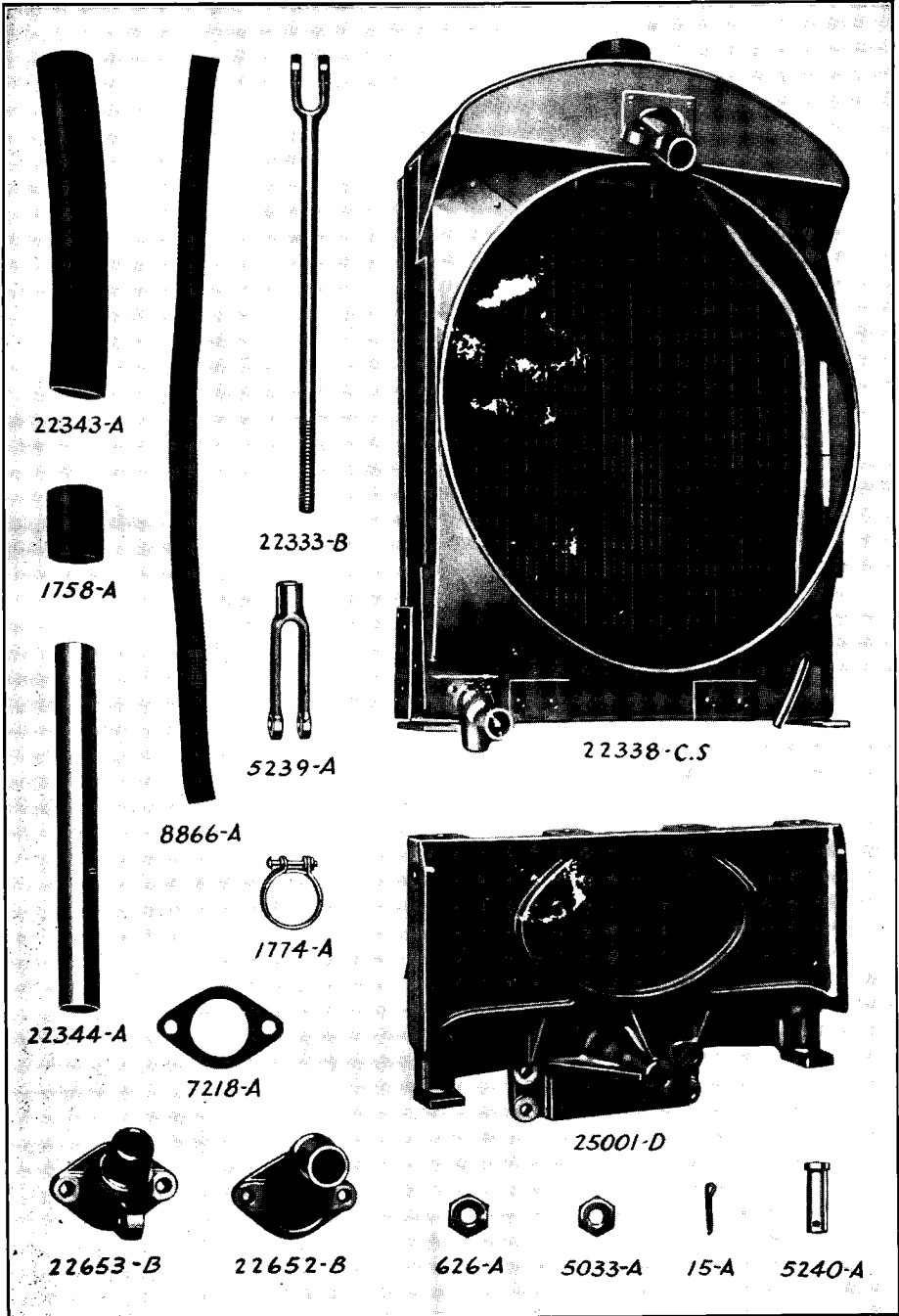

Plate No. 13

Front Support, Radiator, Hose and Water Pipes

MANIFOLD (Continued)

Part No.	No. Req.	PART NAME	Plate No.
22034-D	1	Exhaust and intake manifold (Rear outlet) 1".....	5
■ 22023-B	2	Exhaust and intake manifold gasket (Copper asbestos).....	5
1423-A	2	Exhaust and intake manifold stud (1/16" diam. 4 ³ / ₈ " long).....	5
305-A	1	Exhaust and intake manifold pipe plug (1/8" std.).....	5
834-A	2	Exhaust and intake manifold stud (1/16"x1 ¹⁵ / ₁₆ ").....	5
848-A	4	Exhaust and intake manifold stud nut (1/16"x20").....	5
1388-A	4	Exhaust and intake manifold stud washer (3/8"x2 ²⁹ / ₆₄ "x1/8").....	5
22327-B	1	Companion flange.....	5
22571-B	1	Companion flange.....	
22711-B	1	Companion flange.....	
22027-B	1	Companion flange (Std.).....	5
■ 22328-A	1	Companion flange gasket (Asbestos).....	5
■ 22028-A	1	Companion flange gasket (Std. copper asbestos).....	5
352-A	3	Companion flange screw (1/2"x1 ³ / ₄ "x1 ¹ / ₄ ").....	

MANIFOLD EXTENSION

22602-A	1	Manifold extension, 1 ¹ / ₄ " offset, 2 ³ / ₁₆ " high—parallel flanges.....	5
22620-A	1	Manifold extension, 3 ¹ / ₄ " offset, 3 ³ / ₈ " high—cross flanges.....	
22628-A	1	Manifold extension, 1 ¹ / ₈ " high—cross flanges.....	

DISTRIBUTOR GEAR

22336-A	1	Distributor driving gear.....	4
23335-A	1	Distributor driven gear—Pin hole dia. .136" std.	4
23335-A	1	Distributor driven gear—pin hole dia. .199" special.....	

**GENERATOR GEAR AND COVER
(when generator is used)**

■ 22266-B	1	Generator gear.....	6
■ 22271-A	1	Generator attaching gasket.....	
2100-A	2	Generator attaching screw (1/2"x1 ³ / ₄ "x1").....	
312-A	2	Generator attaching screw lockwasher (1/2" S. A. E.).....	

(when generator is not used)

22270-A	1	Generator opening cover.....	
---------	---	------------------------------	--

MAGNETO EQUIPMENT

22045-B	1	Magneto bracket.....	1
2100-A	2	Magneto bracket screw (1/2"x1 ³ / ₄ "x1" long).....	6
312-A	2	Magneto bracket screw lockwasher (1/2" S. A. E.).....	8

CABLE TUBE

22019-BSY	1	Cable tube assembly.....	3
-----------	---	--------------------------	---

WATER OUTLET PIPES

There is such a wide variety of water inlet and outlet pipes used it is impossible to list them in a book of this size. Many manufacturers using these models of engines supply their own special pipes which the Hercules Motors Corporation do not usually service. When ordering give engine number and a complete description of pipe wanted, giving outside and inside diameters, angles and length together with kind of material or send in the water pipe as a sample.

22650-B	1	Water outlet pipe (1 ¹ / ₄ " O. D.—35°).....	7
22666-B	1	Water outlet pipe 2" O. D. 5 ¹ / ₄ " high.....	
22660-B	1	Water outlet pipe 2" O. D. support lug on left side.....	
22664-B	1	Water outlet pipe support lug on side.....	7
22670-A	1	Water outlet pipe 2" O. D. 4 ¹ / ₂ " high.....	
22678-A	1	Water outlet pipe 1 ¹ / ₂ " O. D. 27°.....	

Give Engine Number with Each Parts Order

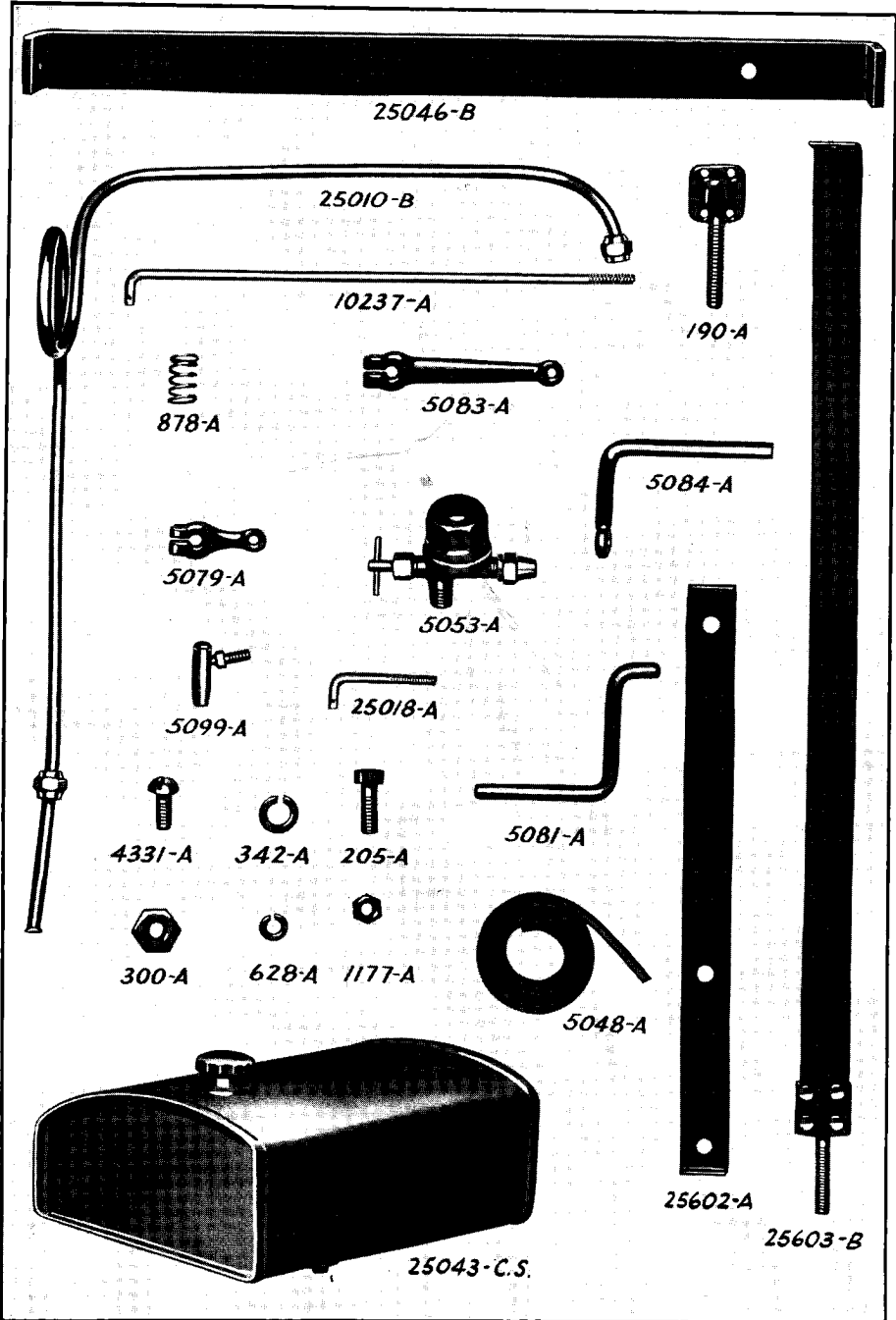

Plate No. 14

Gasoline Tank, Supports, Strainer and Line

WATER OUTLET PIPES (Continued)

Part No.	No. Req.	PART NAME	Plate No.
22682-B	1	Water outlet pipe with support lug on top.....	
22662-B	1	Water outlet pipe (1 $\frac{1}{4}$ " O. D. 45°).....	
22709-C		Water outlet pipe (2 $\frac{1}{4}$ " O. D. with support lugs on both sides).....	
87-A	1	Cylinder head to outlet pipe gasket (1 $\frac{1}{32}$ " Vellumoid).....	7
315-A	2	Cylinder head to outlet pipe cap screw (3 $\frac{3}{8}$ "x16x1 $\frac{1}{8}$ ").....	7
342-A	2	Cylinder head to outlet pipe screw lockwasher (3 $\frac{3}{8}$ " S. A. E.).....	6

WATER INLET PIPES

22663-B	1	Water inlet pipe 2" O. D. (Thermo syphon).....	7
22651-B	1	Water inlet pipe.....	7
22655-A	1	Water inlet pipe 1 $\frac{1}{4}$ " O. D.	7
22665-B	1	Water inlet pipe 1 $\frac{1}{4}$ " O. D. 1 $\frac{1}{8}$ " Pipe tap hole in side.....	
86-A	1	Attaching gasket (1 $\frac{1}{32}$ " Vellumoid).....	7
303-A	2	Attaching screw (5 $\frac{16}{16}$ "x18x3 $\frac{3}{4}$ ").....	7
615-A	2	Attaching screw lockwasher (3 $\frac{16}{16}$ " S. A. E.).....	7

THERMO SYPHON PIPES

22687-C	1	Water inlet pipe—special.....	
22663-B	1	Water inlet pipe (std.).....	7
7218-A	1	Attaching gasket (1 $\frac{1}{32}$ " Vellumoid).....	7
1864-A	2	Attaching screw (3 $\frac{3}{8}$ "x16x1").....	7
342-A	2	Attaching screw lockwasher (3 $\frac{3}{8}$ " S. A. E.).....	6
22057-B	1	Filter pad cover plate.....	7
2100-A	3	Filter pad cover plate attaching screw (1 $\frac{1}{2}$ "x13x1").....	7
352-A	1	Filter pad cover plate attaching screw (1 $\frac{1}{2}$ "x13x1 $\frac{1}{4}$ ").....	7
312-A	4	Filter pad cover plate attaching screw lockwasher.....	8
22150-A	1	Filter pad cover plate gasket.....	

STARTING CRANK (Short Type)

22279-CS	1	Starting crank assembly (Including parts marked *).....	7
22280-B	1*	Starting crank (The distance from the cotter pin hole to the end is 4 $\frac{1}{32}$ ").....	
22282-A	1*	Starting crank spring.....	7
4268-A	1*	Starting crank washer (1 $\frac{1}{8}$ "x1 $\frac{1}{4}$ ").....	6
4448-A	1*	Starting crank pin (3 $\frac{16}{16}$ "x1 $\frac{13}{16}$ ").....	
1710-A	1*	Starting crank cotter pin (1 $\frac{1}{8}$ "x1").....	7
4460-A	1*	Starting crank collar.....	
4199-A	1*	Starting crank collar key (No. 3 Woodruff).....	

FRONT SUPPORT

22284-C	1	Front support (Used with starting crank assembly 22279-CS).....	7
8533-A	4	Front support screw (1 $\frac{1}{2}$ "x13x1 $\frac{1}{2}$ ").....	2
312-A	4	Front support screw lockwasher (1 $\frac{1}{2}$ " S. A. E.).....	7

STARTING CRANK (Long Type)

22278-CS	1	Starting crank assembly (Includes all parts marked *).....	7
22277-CS	1	Starting crank assembly (Trunion type includes all parts marked †).....	
22288-B	1†*	Starting crank (The distance from the cotter pin hole to the end is 5 $\frac{13}{16}$ ").....	
22282-A	1†*	Starting crank spring.....	7
4268-A	1†*	Starting crank washer (1 $\frac{1}{8}$ "x1 $\frac{1}{4}$ ").....	6
1710-A	1†*	Starting crank cotter pin (1 $\frac{1}{8}$ "x1").....	7
4448-A	1†*	Starting crank pin (3 $\frac{16}{16}$ "x1 $\frac{13}{16}$ ").....	
22287-C	1*	Front support (Use with 22278-CS assy.).....	7
4460-A	1†*	Starting crank collar.....	
4199-A	1†*	Starting crank collar key (No. 3 Woodruff).....	
22285-C	1†	Front support (Trunion type use with 22277-CS assy.).....	7
8533-A	4	Front support screw (1 $\frac{1}{2}$ "x13x1 $\frac{1}{2}$ ").....	2
312-A	4	Front support screw lockwasher (1 $\frac{1}{2}$ " S. A. E.).....	8

Give Engine Number with Each Parts Order

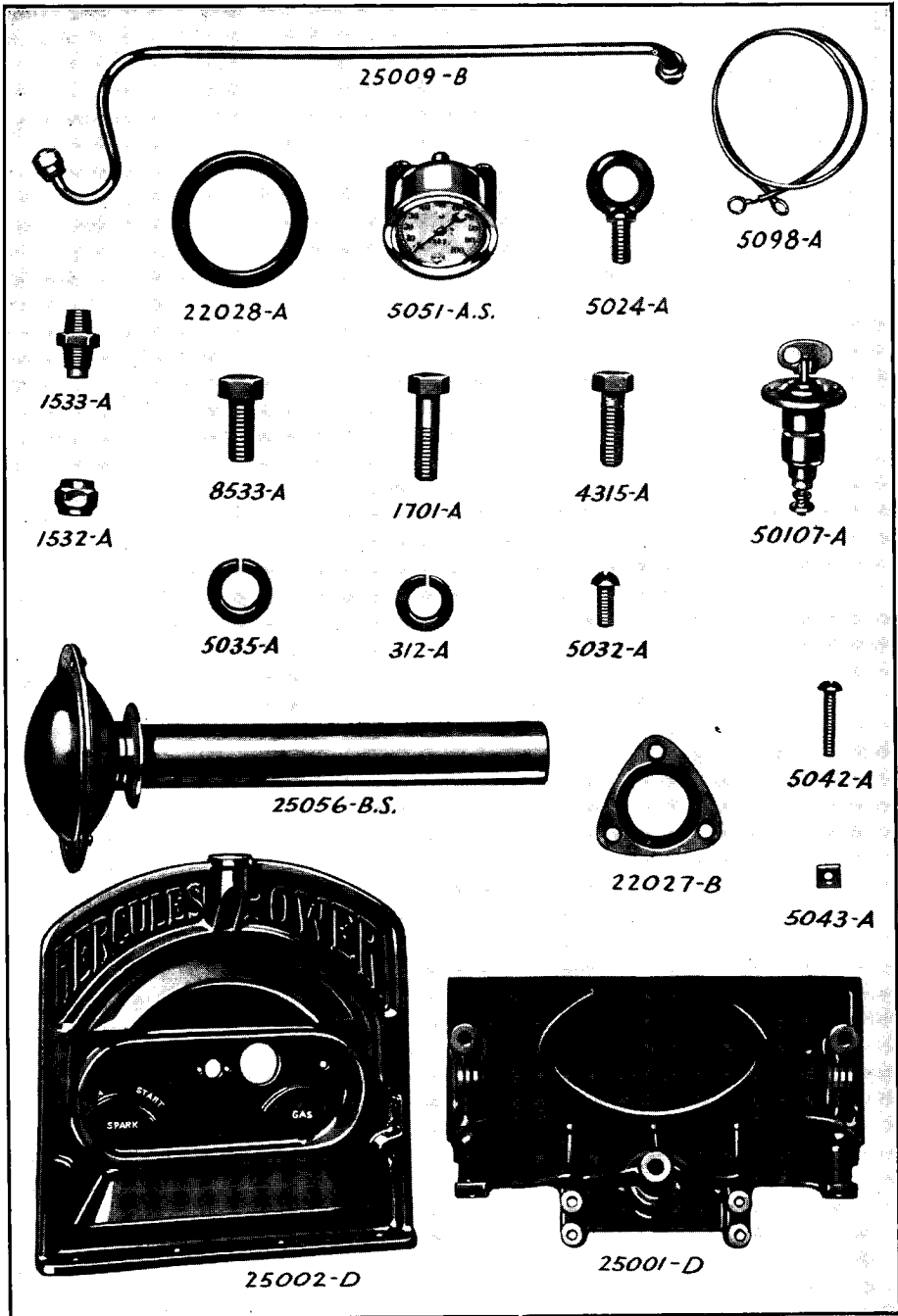

Plate No. 15

Front Support, Instrument Panel and Muffler

TRUNION BRACKET

Part No.	No. Req.	PART NAME	Plate No.
22286-B	1	Trunion bracket (Use with front support No. 22285-C).....	7
4038-A	1	Attaching screw (1/2"x13x3 1/2").....	7
312-A	1	Attaching screw lockwasher (1/2" S. A. E.).....	8
5033-A	1	Attaching screw nut (1/2"x13").....	7

**STARTING CRANK
Long Type (Special)**

22292-CS	1	Starting crank assembly (Includes all parts marked *).....	
22288-B	1*	Starting crank.....	
22282-A	1*	Starting crank spring.....	7
4268-A	1*	Starting crank washer (1/8"x1 1/4").....	6
4448-A	1*	Starting crank pin 5/16"x1 13/16").....	
4460-A	1*	Starting crank collar.....	
4199-A	1*	Starting crank collar key (No. 3 Woodruff).....	
1710-A	1*	Starting crank cotter pin (1/8"x1").....	7
22291-C	1	Front support (Used with starting crank assy. 22292-CS).....	

This support is similar to 22285-C (Plate 7) except that the pad which mounts on the gear cover is 1 1/16" thick instead of 1/2".

8533-A	4	Front support screw (1/2"x13x1 1/2").....	6
312-A	4	Front support lockwasher (1/2" S. A. E.).....	8

STARTER ATTACHING PARTS

22064-A	1	Starter adapter (For No. 5 Housing).....	7
2210-A	2	Starter adapter dowel (Used with above adapter).....	
22066-A	1	Starter adapter (For No. 4 housing).....	7
4303-A	3	Starter attaching stud.....	7
752-A	3	Starter attaching stud nut.....	
342-A	3	Starter attaching stud lockwasher.....	6

When starter is not used, use the following parts:

2055-B	1	Starter hole cover.....	7
8938-A	3	Starter hole screw cover.....	
342-A	3	Starter hole cover screw lockwasher.....	6

FUEL PUMP

23080-BS	1	Fuel pump.....	
22559-CS	1	Fuel pump.....	
■ 22564-A	1	Fuel pump gasket.....	
303-A	2	Fuel pump attaching screw.....	
615-A	2	Fuel pump attaching screw lockwasher.....	
22560-A	1	Fuel pump to carburetor fuel line.....	

When Fuel Pump is not used, use the following parts:

4879-A	1	Fuel pump hole cover.....	
■ 22564-A	1	Fuel pump gasket.....	
1048-A	2	Fuel pump hole cover screw.....	
615-A	2	Fuel pump hole cover screw lockwasher.....	

GOVERNORS

GOVERNOR HEAD ASSEMBLY (HANDY)

23380-CS	1	Governor assembly (Handy) (Includes parts marked *).....	
40445-B	1*	Governor base.....	
40446-B	1*	Governor body.....	
14176-A	4*	Governor body screw No. 10 x24x3/4".....	
1219-A	4*	Governor body screw lock washer.....	

Give Engine Number with Each Parts Order

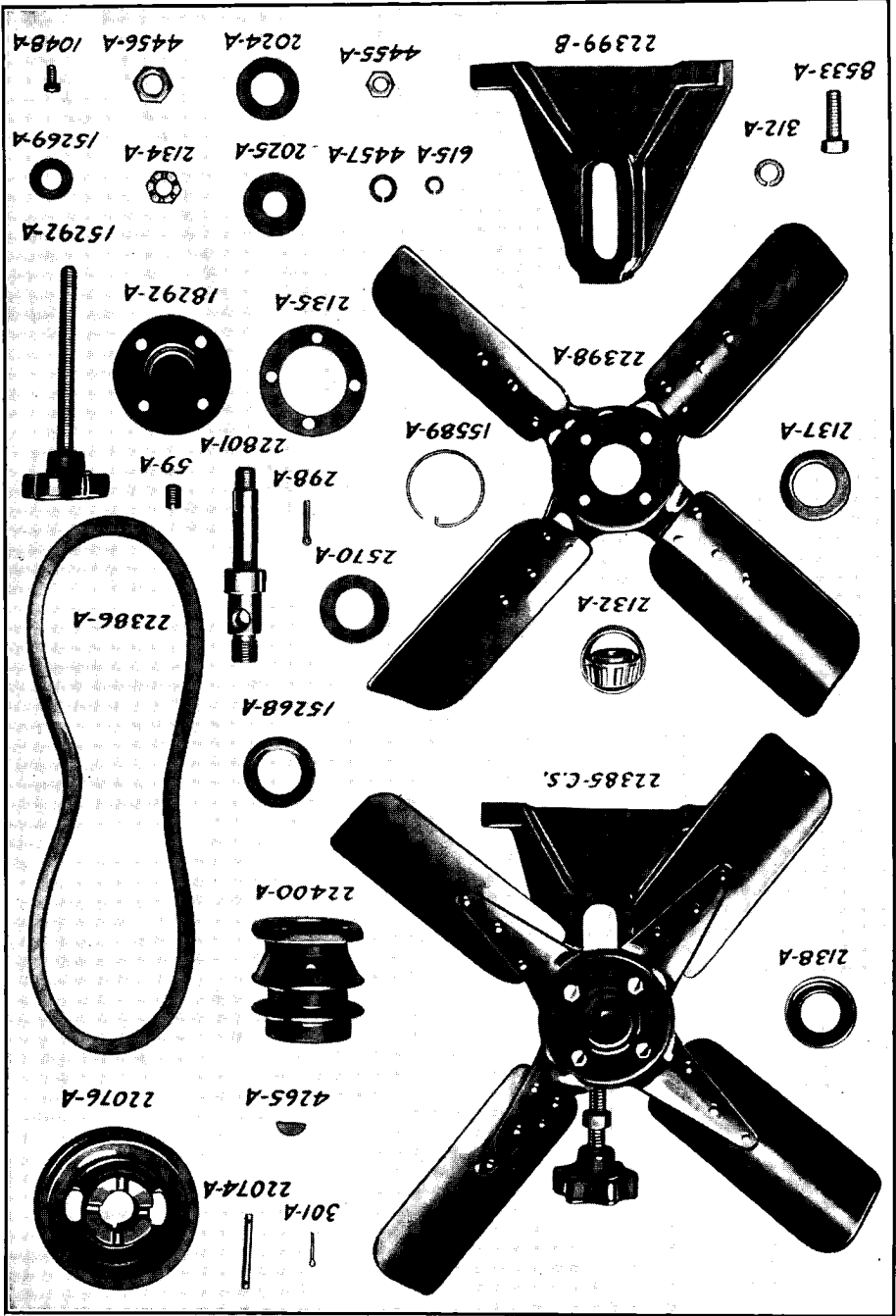

Plate No. 16

Fan Assembly and Parts

GOVERNOR HEAD ASSEMBLY (Continued)

Part No.	No. Req.	PART NAME	Plate No.
■ 58839-A	1*	Governor body gasket.....	
40447-A	1*	Governor body bushing.....	
14578-A	1*	Governor body expansion plug.....	
58841-AS	1*	Governor operating fork assembly.....	
58844-A	2*	Governor operating fork pin.....	
14579-A	1*	Governor operating fork taper pin.....	
40450-A	1*	Governor operating fork riser.....	
58843-A	1*	Governor operating fork thrust bearing.....	
40451-A	1*	Governor operating fork base.....	
40452-A	1*	Governor operating fork base bushing.....	
40453-A	1*	Governor operating shaft.....	
58849-A	2*	Governor operating shaft packing.....	
58850-A	12*	Governor operating shaft roller bearing.....	
14581-A	3*	Governor operating shaft roller bearing retainer.....	
40455-A	1*	Governor operating lever.....	
14579-A	1*	Governor operating lever taper pin.....	
40456-A	1*	Governor operating lever thrust button.....	
23861-A	1*	Governor operating spring, range 1000 R. P. M. to 1500 R. P. M.....	
14682-A	1*	Governor operating spring adjusting screw.....	
14132-A	1*	Governor operating spring adjusting screw lock nut.....	
40457-A	1*	Governor operating spring pilot (Front).....	
40458-A	1*	Governor operating spring pilot (Rear).....	
40460-AS	1*	Governor shaft and weight assembly (Includes parts marked **)......	
40459-A	2**	Governor operating weight.....	
58854-A	2**	Governor operating weight pin.....	
40461-A	1**	Governor operating weight carrier.....	
14681-A	1**	Governor operating weight carrier taper pin.....	
40462-A	1**	Governor shaft.....	
14680-A	1*	Governor shaft snap ring.....	
14585-A	1*	Governor shaft ball bearing.....	
14586-A	2*	Governor shaft ball bearing retainer washer.....	
14587-A	2*	Governor shaft ball bearing retaining washer screw.....	
14588-A	2*	Governor shaft ball bearing retaining washer screw lock washer.....	
40463-A	1*	Governor drive gear.....	
4199-A	1*	Governor drive gear key.....	
58845-A	1*	Governor bumper spring.....	
40464-A	1*	Governor bumper spring screw.....	
14580-A	1*	Governor bumper spring screw lock nut.....	
3196-A	1*	Governor bumper spring screw gasket.....	
■ 10471-A	1	Governor attaching gasket.....	
1872-A	2	Governor attaching screw.....	
335-A	2	Governor attaching screw lock washer.....	

GOVERNOR HEAD ASSEMBLY (Handy)

This governor is same as 23380-CS except the following parts are in addition.
This is a manual control type governor.

23390-CS	1	Governor assembly (Handy).....	
28858-A	1*	Governor operating spring rod.....	
28859-A	1*	Governor operating spring rod pilot.....	
28865-A	1*	Governor manual control lever bracket.....	
4990-A	2*	Governor manual control lever bracket screw.....	
4817-A	2*	Governor manual control lever bracket.....	
28864-A	1*	Governor manual control lever shaft.....	
28863-A	1*	Governor manual control lever.....	
14579-A	1*	Governor manual control lever taper pin.....	

GOVERNOR HEAD ASSEMBLY (Handy)

Same as 23380-CS except operating spring.

40442-CS	1	Governor assembly (Handy).....	
40444-A	1*	Governor operating spring, range over 1600 R. P. M.....	

Give Engine Number with Each Parts Order

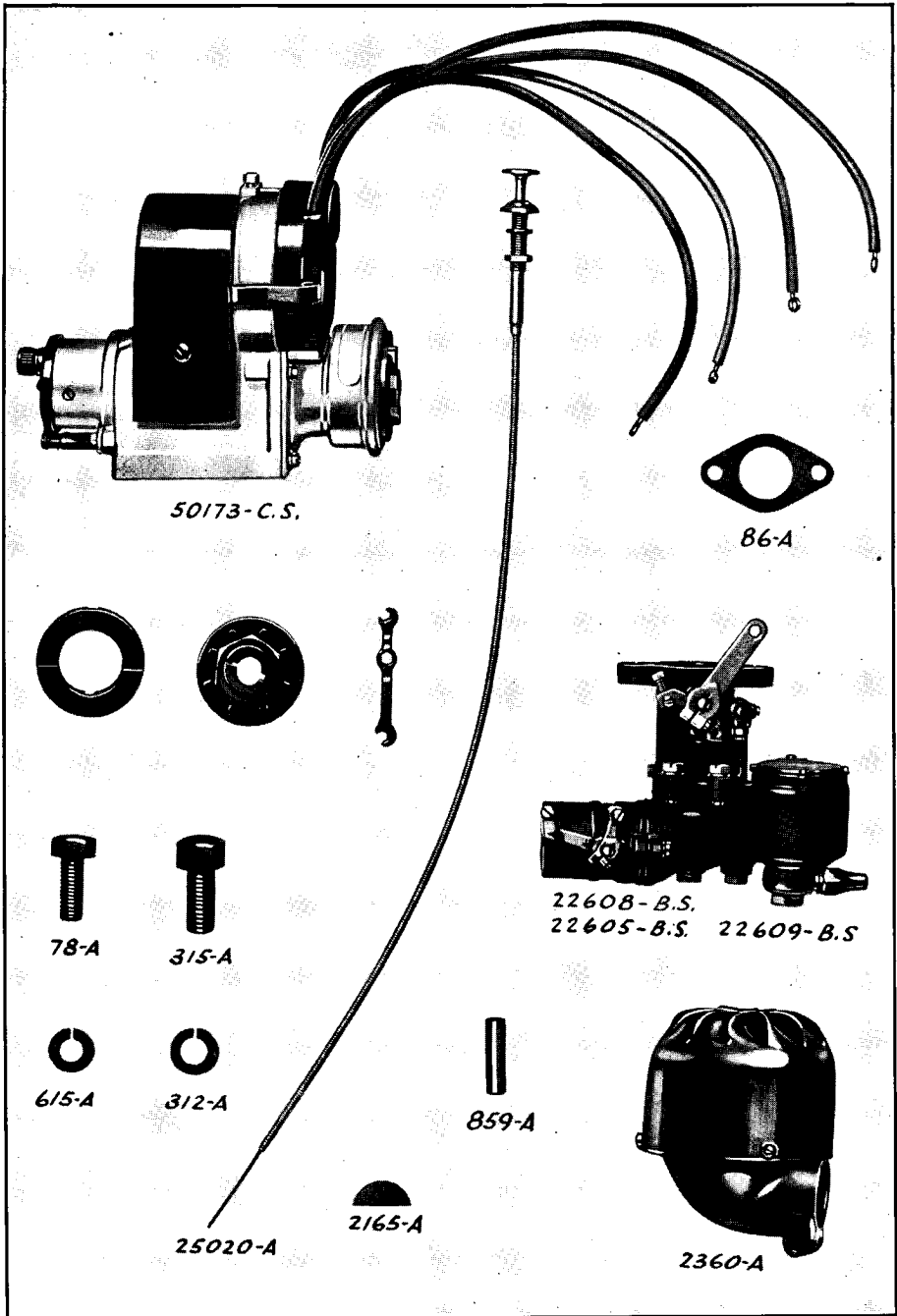

Plate No. 17

Air Cleaner, Carburetor, Choke Wire and Magneto

GOVERNOR HEAD ASSEMBLY

This Governor is distinguished by the shaft being mounted on Timken Bearings. Shown on Plate No. 9 as 22331-CS.

Part No.	No. Req.	PART NAME	Plate No.
22312-CS	1	Governor head assembly (Includes parts marked *)	
5800-B	1*	Governor body	9
5801-A	1*	Governor body cap	9
5846-A	As Req.	*Governor bearing adjusting shim	9
5802-A	2*	Governor bearing (Timken)	9
5803-A	2*	Governor body screw No. 6x32x ³ / ₈ "	
22882-A	2*	Governor weight	
5806-A	1*	Governor weight spider	9
5805-A	2*	Governor weight rivet	9
5807-A	1*	Governor weight spider pin	9
■ 22307-AS	1*	Governor shaft and gear assembly	
5829-A	1*	Governor shaft nut	
5828-A	1*	Governor shaft nut tongue washer	
5810-A	1*	Governor thrust sleeve	9
5811-A	1*	Governor thrust ball bearing	9
5812-A	1*	Governor thrust yoke	9
5842-A	1*	Governor thrust yoke pin	9
5814-A	1*	Governor thrust yoke shaft	9
5817-A	1*	Governor connecting rod lever	9
5813-A	1*	Governor connecting rod lever pin	9
5862-A	1*	Governor speed adjusting spring, range 1050 R.P.M. to 1350 R.P.M.	
5820-A	1*	Governor speed adjusting spring, range 1200 R.P.M. to 1500 R.P.M.	
22348-A	1*	Governor speed adjusting spring, range 1400 R.P.M. to 1800 R.P.M.	9
22572-A	1*	Governor speed adjusting spring, range over 1800 R.P.M.	
		Specify which spring is required when ordering governor.	
5821-A	1*	Governor adjusting spring collar	9
5822-A	1*	Governor adjusting spring bolt	9
5823-A	1*	Governor adjusting spring bolt nut	
5824-A	1*	Governor adjusting spring bolt lock wire	
■ 10471-A	1	Governor attaching gasket	9
1173-A	2	Governor attaching screw ⁷ / ₁₆ "x24x1 ¹ / ₄ "	9
335-A	2	Governor attaching screw lock washer	9

GOVERNOR VALVE BOX ASSEMBLIES

S. A. E. 1" Size (Actual diameter of hole 1³/₁₆"

22337-AS	1	Governor valve box assembly (Including parts marked *)	9
22334-A	1*	Governor valve box	9
5858-A	1*	Governor butterfly valve	9
5838-A	1*	Governor butterfly valve shaft	9
5839-A	2*	Governor butterfly valve screw No. 8x32x ¹ / ₄ "	9
4116-A	2*	Governor butterfly valve lock washer	9
5841-A	1*	Governor butterfly valve shaft lever	9
5842-A	1*	Governor butterfly valve shaft lever pin	9
5853-A	1*	Governor bumper spring	
5854-A	1*	Governor bumper spring screw	9
5855-A	1*	Governor bumper spring screw nut	
2359-A	1	Governor valve box attaching screw (⁹ / ₁₆ "x18x1")	
44-A	1	Governor valve box attaching screw (⁹ / ₁₆ "x24x1 ¹ / ₄ "	
28-A	1	Governor valve box attaching screw nut (⁹ / ₁₆ "x24)	
615-A	2	Governor valve box attaching screw lock washer	
■ 86-A	1	Governor valve box attaching gasket	

S. A. E. 1¹/₄" Size (Actual diameter of hole 1¹/₁₆"

5835-AS	1	Governor valve box assembly (Includes parts marked *)	
5836-A	1*	Governor valve box	
5837-A	1*	Governor butterfly valve	
5838-A	1*	Governor butterfly valve shaft	

Give Engine Number with Each Parts Order

Oil Filtrator and Parts

Plate No. 18

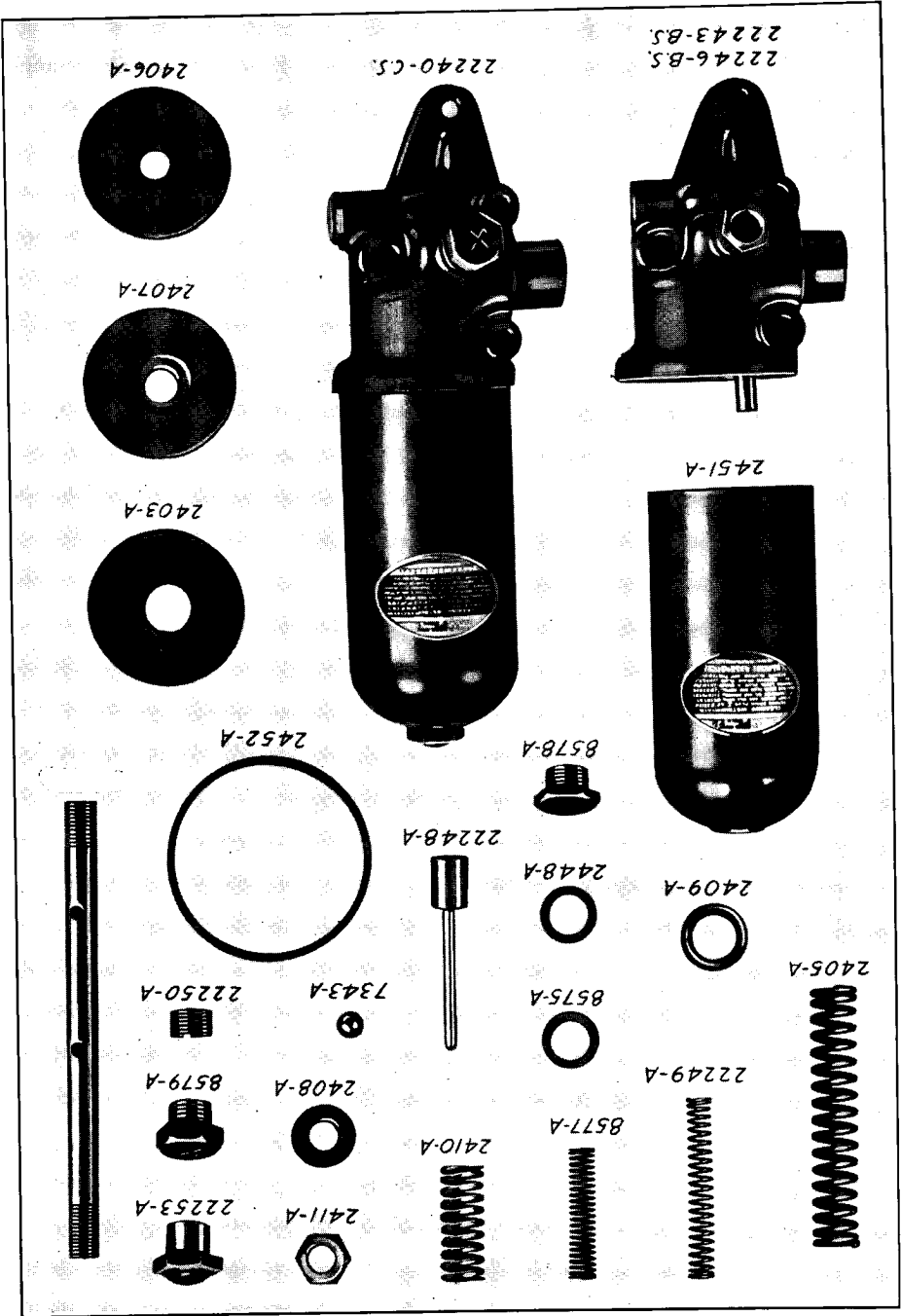

GOVERNOR VALVE BOX ASSEMBLIES (Continued)

Part No.	No. Req.	PART NAME	Plate No.
5839-A	2*	Governor butterfly valve screw.....	9
4116-A	2*	Governor butterfly valve screw lock washer.....	9
5841-A	1*	Governor butterfly valve lever.....	9
5842-A	1*	Governor butterfly valve lever pin.....	9
5853-A	1*	Governor bumper spring.....	
5854-A	1*	Governor bumper spring screw.....	9
5855-A	1*	Governor bumper spring screw nut.....	
1864-A	1	Governor valve box attaching screw (3/8"x16x1").....	9
1183-A	1	Governor valve attaching screw (3/8"x24x1 1/2").....	9
752-A	1	Governor valve box attaching screw nut (3/8"x24).....	9
342-A	2	Governor valve box attaching screw lock washer.....	9
87-A	1	Governor valve box attaching gasket.....	9

S. A. E. 1" to 1 1/4" size. (Actual diameter of hole 1 3/16")

5856-AS	1	Governor valve box assembly (Includes parts marked *).....	
5857-A	1*	Governor valve box.....	
5858-A	1*	Governor butterfly valve.....	9
5838-A	1*	Governor butterfly valve shaft.....	9
5839-A	2*	Governor butterfly valve screw.....	9
4116-A	2*	Governor butterfly valve lock washer.....	9
5841-A	1*	Governor butterfly valve lever.....	9
5842-A	1*	Governor butterfly valve lever pin.....	9
5853-A	1*	Governor bumper spring.....	
5854-A	1*	Governor bumper spring screw.....	9
5855-A	1*	Governor bumper spring screw nut.....	

Use same attaching parts as listed above for 1 1/4" Valve Box Assembly.

OFFSET VALVE BOX

S. A. E. 1 1/4" to 1" size

22310-BS	1	Governor valve box assembly (Includes parts marked *).....	
22311-B	1*	Governor valve box.....	
5858-A	1*	Governor butterfly valve.....	9
5838-A	1*	Governor butterfly valve shaft.....	9
5839-A	2*	Governor butterfly valve screw.....	9
4116-A	2*	Governor butterfly valve lock washer.....	9
5841-A	1*	Governor butterfly valve lever.....	9
5842-A	1*	Governor butterfly valve lever pin.....	9
5853-A	1*	Governor bumper spring.....	
5854-A	1*	Governor bumper spring screw.....	
5855-A	1*	Governor bumper spring nut.....	9

Use same attaching parts as listed for the 1 1/4" Valve Box Assembly.

GOVERNOR AND VALVE BOX ASSEMBLIES

22331-CS	1	Governor and valve box assembly (Includes parts marked *).....	9
22312-CS	1*	Governor head assembly.....	
22337-AS	1*	Governor valve box assembly.....	9
22330-A	1*	Governor connecting rod.....	9
984-A	2*	Governor connecting rod washer.....	9
301-A	2*	Governor connecting rod cotter pin.....	9
22332-CS	1	Governor and valve box assembly includes same as 22331-CS except..	
5835-AS	1	Governor valve box instead of 22337-AS.....	
22346-CS	1	Governor and valve box assembly includes same as 22331-CS except..	
5856-AS	1	Governor valve box assembly instead of 22337-AS.....	
22313-CS	1	Governor and valve box assembly (Includes parts marked **).....	
22312-CS	1**	Governor head assembly.....	
22310-BS	1**	Governor valve box assembly.....	
22314-A	1**	Governor connecting rod.....	
984-A	2**	Governor connecting rod washer.....	9
301-A	2**	Governor connecting rod cotter pin.....	9

Give Engine Number with Each Parts Order

OIL FILTRATOR

(Used with Water Pump and eliminates Water Pump Discharge Pipe 22176-B)

Part No.	No. Req.	PART NAME	Plate No.
22240-CS	1	Oil filtrator assembly (Includes parts marked *)	18
22246-BS	1*	Oil filtrator base and inlet tube	18
2445-A	1*	Oil filtrator shell	
		Takes Place of Part No. 2451-A—Plate No. 18	
■ 2452-A	1*	Oil filtrator shell gasket	18
18245-A	1*	Oil filtrator shell cap nut	
		Takes Place of Part No. 22253-A—Plate No. 18	
2448-A	1*	Oil filtrator shell cap nut gasket	18
7330-A	1*	Oil filtrator base inlet tube	
22248-A	1*	Oil filtrator oil reverse valve	18
2379-A	1*	Oil filtrator oil reverse valve bushing	
22249-A	1*	Oil filtrator oil reverse valve spring	18
8579-A	1*	Oil filtrator drain plug	18
8575-A	1*	Oil filtrator drain plug gasket	18
7343-A	1*	Oil filtrator differential valve ball	18
8577-A	1*	Oil filtrator differential valve spring	18
8578-A	1*	Oil filtrator differential valve plug	18
8575-A	1*	Oil filtrator differential valve plug gasket	18
■ 22251-BS	1*	Oil filtrator slug assembly (Includes parts marked **)	

On orders for a complete set of felts the Slug Assembly will be furnished.

2403-A	21**	Oil filtrator felt washers	18
22252-A	1**	Oil filtrator outlet tube	18
2406-A	1**	Oil filtrator felt retaining washer (Top)	18
2407-A	1**	Oil filtrator felt retaining washer (Bottom)	18
2405-A	1**	Oil filtrator spacer coil	18
2408-A	1**	Oil filtrator cork washer	18
2409-A	1**	Oil filtrator cork washer retainer	18
2410-A	1**	Oil filtrator compression spring	18
2411-A	1**	Oil filtrator compression spring nut	18
2808-A	1*	Oil filtrator name plate	
■ 22150-A	1	Oil filtrator gasket	
1608-A	3	Oil filtrator attaching screw	
352-A	1	Oil filtrator attaching screw	
312-A	4	Oil filtrator attaching screw lock washer	

TOOLS

The wrenches listed below are essential to proper maintenance of OO series engines and may be procured from the HERCULES MOTORS CORP., Canton, Ohio.

2249-A	1	Socket— ³ / ₄ "	
2248-A	1	Socket— ⁵ / ₈ "	
2247-A	1	Socket— ⁹ / ₁₆ "	
2251-A	1	Socket— ⁷ / ₈ "	
2245-A	1	Speeder Handle	
4976-A	1	Plain T Handle	
4978-A	1	Open End Wrench— ⁹ / ₁₆ "x ⁵ / ₈ "	
2258-A	2	Open End Tappet Wrench— ¹ / ₂ "	
2255-A	1	Oil Adjusting Socket Wrench	
2268-A	1	Oil Adjusting Crowfoot Wrench	

Give Engine Number with Each Parts Order

Model "OOA"

Supplement showing parts which are different from model "OOB". The model "OOA" has 3 1/2" cylinders, the model "OOB" has 3 3/4" cylinders.

CYLINDER AND CRANKCASE

Part No.	No. Req.	PART NAME	Plate No.
22000-ESY	1	Cylinder and crankcase with valve guides, push rod guides, camshaft bearings, idler gear bearing.....	1
22320-DS	1	Cylinder and crankcase with the above parts also main bearings, caps and screws all reamed to size.....	

CYLINDER HEAD

22102-D	1	Cylinder head, 4.2 compression ratio.....	
22739-D	1	Cylinder head, 4.2 compression ratio, 18 m. m. spark plug holes.....	
22740-D	1	Cylinder head, 4.2 compression ratio, thermo syphon.....	
22741-D	1	Cylinder head, 4.75 compression ratio.....	
22743-D	1	Cylinder head, 4.6 compression ratio, 18 m. m. spark plug holes.....	
22745-D	1	Cylinder head, 4.7 compression ratio, flat type.....	
22756-D	1	Cylinder head, 5.6:1 compression ratio—natural gas.....	
■ 22003-C	1	Cylinder head gasket.....	1

PISTON (Cast ron)

See note about oversizes on page 8

The 22118-C piston has been superseded by piston 22209-C which has four ring grooves while the 22118-C piston has only three piston ring grooves. The 22118-C piston is listed here for convenience in ordering parts for engines equipped with this three ring type piston. On orders for new pistons the 22209-C piston will be supplied.

22118-CSY	4	Piston with bushings, three ring type.....	2
18501-A	8	Piston ring, compression.....	2
40019-A	4	Piston ring, oil regulating.....	
40128-B	4	Piston pin.....	
22117-A	8	Piston pin bushing.....	2

PISTON (Cast Iron)

See note about oversizes on page 8

■ 22209-CSY	4	Piston, with bushings, four ring type.....	
■ 22212-A	12	Piston ring, compression.....	
■ 40019-A	4	Piston ring, oil regulating.....	
■ 40128-B	4	Piston pin.....	
22117-A	8	Piston pin bushing.....	2

PISTON (Aluminum)

See note about oversizes on page 8

■ 22096-C	4	Piston.....	
■ 22212-A	12	Piston ring, compression.....	
■ 40019-A	4	Piston ring, oil regulating.....	
■ 40128-B	4	Piston pin.....	

Give Engine Number with Each Parts Order

Model "OOC"

Supplement showing parts which are different from model "OOB". The model "OOC" has 4" cylinders, the model "OOB" has 3¾" cylinders.

CYLINDER AND CRANKCASE

Part No.	No. Req.	PART NAME	Platc No.
22200-ESY	1	Cylinder and crankcase with valve guides, push rod guides, camshaft bearings, idler gear bearings.....	1
22321-DS	1	Cylinder and crankcase with the above parts—also main bearings, caps and screws all reamed to size.....	

CYLINDER HEAD

22202-D	1	Cylinder head, 4.28:1 compression ratio.....	1
22733-D	1	Cylinder head, 4.2:1 compression ratio, 18 m. m. spark plug holes.....	
22734-D	1	Cylinder head, 3.73:1 compression ratio, kerosene.....	
22735-D	1	Cylinder head, high compression, natural gas.....	
22738-D	1	Cylinder head, 4.2:1 compression ratio, dual ignition.....	
22744-D	1	Cylinder head, high compression, natural gas, 18 m. m. spark plug holes.....	
22747-D	1	Cylinder head, 4.7:1 compression, flat type.....	
22748-D	1	Cylinder head, 4.61:1 compression ratio.....	
22749-D	1	Cylinder head, 5.09:1 compression ratio.....	
22750-D	1	Cylinder head, 5.7:1 compression ratio.....	
22752-D	1	Cylinder head, 4.95:1 compression ratio.....	
22753-D	1	Cylinder head, 5.3:1 compression ratio.....	
22754-D	1	Cylinder head, 4.0:1 compression ratio.....	
22757-D	1	Cylinder head, 5.12:1 compression ratio.....	1
■ 22003-C	1	Cylinder head gasket.....	

PISTON (Cast Iron)

See note about oversizes on page 8

The 22221-C piston has been superseded by piston 22224-C which has four ring grooves while the 22221-C piston has only three ring grooves. The 22221-C piston is listed here for convenience in ordering parts for engines equipped with this three ring type piston. On orders for new pistons the 22224-C piston will be supplied.

22221-CSY	4	Piston with bushings, three ring type.....	2
2815-A	8	Piston ring, compression.....	
2817-A	4	Piston ring, oil regulating.....	2
22238-B	4	Piston pin.....	2
22217-A	8	Piston pin bushing.....	2

PISTON (Cast Iron)

See note about oversizes on page 8

These pistons were first used on engine number 229705 and all OOC engines with a serial number higher.

■ 22224-CSY	4	Piston with bushings, four ring type.....	
■ 22213-A	12	Piston ring, compression.....	
■ 2817-A	4	Piston ring, oil regulating.....	2
■ 22238-B	4	Piston pin.....	2
22217-A	8	Piston pin bushing.....	

PISTON (Aluminum)

See note about oversizes on page 8

■ 22098-C	4	Piston.....	
■ 22213-A	12	Piston ring, compression.....	
■ 2817-A	4	Piston ring, oil regulating.....	2
■ 22238-B	4	Piston pin.....	

Give Engine Number with Each Parts Order

Power Unit

As there are many special controls as well as other parts used on the power units, it is always advisable to give either engine or unit number or both when ordering replacement parts.

MAGNETO

Part No.	No. Req.	PART NAME	Plate No.
50329-CS	1	Magneto (Bosch MJC4A).....	17
315-A	2	Magneto to bracket screw ($\frac{3}{8}$ "x $1\frac{1}{2}$ "x $\frac{1}{8}$ ").....	17
342-A	3	Magneto to bracket screw lockwasher ($\frac{3}{8}$ " S. A. E.).....	12
2165-A	1	Magneto coupling key No. 8—Woodruff.....	17
859-A	1	Magneto coupling taper pin (No. 3x1" long).....	17
203-A	1	Magneto to bracket dowel screw.....	17

GOVERNOR

For details see page 42

22346-CS	1	Governor 1" to $1\frac{1}{4}$ " for 1" Carburetor.....	
■ 10471-A	1	Governor gasket.....	9
1173-A	2	Governor attaching bolt ($\frac{1}{16}$ "x $1\frac{1}{4}$ "x $\frac{1}{4}$ ").....	9
335-A	2	Governor attaching lockwasher ($\frac{1}{16}$ " S. A. E.).....	9

CARBURETOR

22608-B5	1	Carburetor 1" for "OOAPU".....	17
22609-B5	1	Carburetor 1" for "OOBPU".....	17
22605-B5	1	Carburetor 1" for "OOCPU".....	17
■ 86-A	1	Carburetor attaching gasket.....	17
78-A	2	Carburetor attaching screw ($\frac{5}{16}$ "x $1\frac{1}{8}$ "x $\frac{1}{8}$ ").....	17
615-A	2	Carburetor attaching screw lockwasher ($\frac{5}{16}$ " S. A. E.).....	17
25020-A	1	Carburetor choke control.....	17

AIR CLEANER

The centrifugal, windmill type air cleaner formerly used has been replaced by the "Air Maze" screen type air cleaner.

29070-B5	1	Air cleaner.....	
----------	---	------------------	--

FAN ASSEMBLY

The 22385-CS Fan assembly has been replaced by 23281-CS Fan Assembly. These can readily be distinguished as the 22385-CS assembly has the adjusting screw on top of the bracket while the 23281-CS assembly has no adjusting screw.

22385-CS	1	Fan assembly (Includes parts marked *).....	16
8533-A	2	Fan assembly attaching screw ($\frac{1}{2}$ "x $1\frac{1}{2}$ "x $\frac{1}{2}$ ").....	16
312-A	2	Fan assembly attaching screw lockwasher ($\frac{1}{2}$ " S. A. E.).....	16
22398-B	1*	Fan blade assembly.....	16
22400-A	1*	Fan hub.....	16
22401-A	1*	Fan shaft.....	16
Takes Place of Part No. 22801-A—Plate No. 16			
2132-A	2*	Fan bearing (Timken).....	16
1048-A	4*	Fan blade screw.....	16
615-A	4*	Fan blade screw lockwasher.....	16
2135-A	1*	Fan hub to blade gasket.....	16
59-A	1*	Fan hub oil plug.....	16
18292-A	1*	Front cap.....	16
2134-A	1*	Clamp nut.....	16
298-A	1*	Clamp nut cotter.....	16

Give Engine Number with Each Parts Order

FAN ASSEMBLY (Continued)

Part No.	No. Req.	PART NAME	Plate No.
15269-A	1*	Clamp washer.....	16
15268-A	1*	Oil gasket.....	16
2138-A	1*	Cork retaining washer.....	16
2570-A	1*	Cork washer.....	16
2137-A	1*	Cork retainer.....	16
15298-A	1*	Lock wire.....	
Takes Place of Part No. 15589-A—Plate No. 16			
2024-A	1*	Clamp washer (1" Hole).....	16
2025-A	1*	Clamp washer ($\frac{3}{4}$ " Hole).....	16
22399-B	1*	Fan bracket.....	16
9264-A	1*	Fan adjusting screw.....	
4455-A	1*	Jam nut.....	16
4456-A	1*	Lock nut.....	16
4457-A	1*	Lockwasher.....	16

FAN ASSEMBLY

The 23281-CS Fan Assembly replaces the 22385-CS Fan Assembly.

23281-CS	1	Fan assembly (Includes parts marked *).....	
23292-CS	1*	Fan blade assembly.....	
23293-CS	1*	Fan hub assembly.....	
23294-A	1*	Fan shaft assembly.....	
23296-B	1*	Fan shaft bearing.....	
23297-A	1*	Fan blade spacer.....	
14113-A	1*	Fan oil hole plug.....	
14112-A	8*	Fan blade screw.....	
14403-A	8*	Fan blade lock washer.....	
23298-A	4*	Fan blade screw double nut.....	
23299-A	1*	Fan bracket.....	
23300-A	1*	Fan clamp washer $\frac{3}{16}$ " thick.....	
40503-A	1*	Fan clamp washer $\frac{1}{8}$ " thick.....	
302-A	1*	Fan shaft cotter pin.....	
1124-A	1*	Fan shaft nut.....	
8533-A	2	Fan attaching screw.....	16
312-A	2	Fan attaching screw lock washer.....	16

FAN BELT

Used with both Fan Assemblies

■ 22386-A	1	Fan belt, "V" type.....	16
-----------	---	-------------------------	----

FAN PULLEY

22072-B	1	Fan pulley.....	
Takes Place of Part No. 22076-B—Plate No. 1			
22071-A	1	Fan pulley pin.....	

BELLHOUSING

25000-D	1	Bellhousing (or rear motor support) No. 4 S.A.E.....	10
2055-B	1	Bellhousing starter cover.....	7
8938-A	3	Bellhousing starter cover screw ($\frac{3}{8}$ " x $1\frac{1}{8}$ " S.A.E.).....	10
342-A	3	Bellhousing starter cover screw lockwasher ($\frac{3}{8}$ " S.A.E.).....	10

STARTING CRANK

22288-B	1	Starting crank.....	
22282-A	1	Starting crank spring.....	7
4268-A	1	Starting crank washer.....	
4448-A	1	Starting crank pin.....	
1710-A	1	Starting crank cotter pin.....	7
4460-A	1	Starting crank collar.....	
4199-A	1	Starting crank key.....	

Give Engine Number with Each Parts Order

HOOD

Part No.	No. Req.	PART NAME	Plate No.
25329-DSY	1	Hood assembled with latch hook—does not have exhaust pipe bracket	
25045-DSY	1	Hood assembled with latch hook and exhaust pipe bracket	10
5048-A	2	Hood antisqueak ($\frac{3}{4}$ " wide $33\frac{1}{4}$ " long)	14
5036-A	4	Hood attaching screw No. 24— 16×1 "	10
300-A	4	Hood attaching screw nut ($\frac{3}{8}$ " $\times 16$ ")	10
342-A	4	Hood attaching screw lockwasher ($\frac{3}{8}$ " S.A.E.)	10
25003-A	4	Hood latch hook	10
4314-A	12	Hood latch hook rivet ($\frac{3}{16}$ " $\times 3\frac{3}{8}$ ")	10
25060-A	1	Hood exhaust pipe clamp bracket	10
5032-A	3	Hood exhaust pipe clamp bracket rivet ($\frac{1}{4}$ " $\times 5\frac{3}{8}$ ")	10
1701-A	2	Hood exhaust pipe clamp bracket clamp screw	10

HOOD SIDE PANEL

25007-CSY	1	Side panel R. H. assembled with hood latches and buttons	10
25006-CSY	1	Side panel L. H. assembled with hood latches and buttons	10
25036-A	4	Side panel buttons	10
25038-BS	4	Side panel latch and hook assembly	10
4314-A	12	Side panel rivets ($\frac{3}{16}$ " $\times 5\frac{3}{8}$ ")	10

INSTRUMENT PANEL

25002-D	1	Instrument panel	15
4315-A	4	Instrument panel to bellhousing screw ($\frac{3}{16}$ " $\times 12 \times 1\frac{3}{16}$ ")	15
5035-A	4	Instrument panel to bellhousing screw lockwasher	15
5051-A	1	Instrument panel oil gauge	15
25009-A	1	Instrument panel oil gauge pipe	15
1532-A	2	Instrument panel oil gauge pipe nut	15
1533-A	1	Instrument panel oil gauge pipe union	15
50201-A	1	Instrument panel ignition switch	
		Takes Place of Part No. 50107-A—Plate No. 15	
5042-A	2	Instrument panel ignition switch screw	15
5043-A	2	Instrument panel ignition switch screw nut	15
5098-A	1	Instrument panel ignition switch ground wire ($17\frac{3}{8}$ " long)	15
5024-A	4	Instrument panel eye bolt	15

FRONT MOTOR SUPPORT

25001-D	1	Front motor support	15
8552-A	4	Front motor support attaching screw	
		Takes Place of Part No. 8533-A—Plate No. 15	
312-A	4	Front motor support attaching screw lockwasher	15
5024-A	2	Front motor support eye bolt	15

MUFFLER

25330-BS	1	Muffler and exhaust pipe assembly—latest type—threaded	
25056-BS	1	Muffler and exhaust pipe assembly—early type	15
25060-B	1	Exhaust pipe clamp bracket	10
5032-A	3	Exhaust pipe clamp bracket rivet	15
1701-A	1	Exhaust pipe clamp bracket clamp screw	15

RADIATOR

25015-DSY	1	Radiator assembly (Includes parts marked *)	
25015-D	1*	Radiator core	12
25013-D	1*	Radiator shell	12
25011-A	1*	Radiator top hose	12
1774-A	2*	Radiator hose clamp	12
5040-A	1*	Radiator cap (screw on type)	12

Give Engine Number with Each Parts Order

RADIATOR (Continued)

Part No.	No. Req.	PART NAME	Plate No.
29046-A	1*	Radiator cap ("easy on" type).....	12
1756-A	1*	Radiator bottom hose.....	12
1774-A	2*	Radiator hose clamp.....	12
4331-A	8*	Radiator screw (Holds shell to core).....	12
300-A	8*	Radiator screw nut (Holds shell to core).....	12
342-A	8*	Radiator screw lock washer.....	12
1729-A	4*	Radiator screw (Attach core to shell).....	12
5034-A	4*	Radiator screw nut (Attach core to shell).....	12
628-A	4*	Radiator screw lock washer.....	12
4315-A	2	Radiator attaching screw (Core to front support).....	12
5035-A	2	Radiator attaching screw lock washer.....	12
5076-A	1*	Radiator drain coupling.....	12
5077-A	1*	Radiator drain nipple $2\frac{1}{2}$ " long.....	12
5097-A	1*	Radiator drain nipple $\frac{7}{8}$ " long.....	12
5075-A	1*	Radiator drain elbow.....	12
620-A	1*	Radiator drain pipe plug.....	12

TIE ROD

The tie rod parts have been eliminated on all power units after unit No. 04571 as they are not necessary and it is advisable to remove these parts from all earlier units.

GAS CONTROL

5081-A	1	Gas control lever.....	14
878-A	1	Gas control lever spring.....	14
5079-A	1	Gas control short lever.....	14
205-A	1	Gas control short lever screw.....	14
628-A	1	Gas control short lever screw lockwasher.....	14
25018-A	1	Gas control short rod.....	14
5099-A	1	Gas control short rod ball joint.....	14
1177-A	1	Gas control short rod ball joint nut.....	14
628-A	1	Gas control short rod ball joint lockwasher.....	14
10-A	1	Gas control short rod cotter pin.....	11
5083-A	1	Gas control center lever.....	14
5084-A	1	Gas control long lever.....	14
205-A	1	Gas control long lever screw.....	14
628-A	1	Gas control long lever screw lockwasher.....	14
10237-A	1	Gas control rod long.....	14
5099-A	1	Gas control rod long ball joint.....	14
1177-A	1	Gas control rod long ball joint nut.....	14
628-A	1	Gas control rod long ball joint lockwasher.....	14
10-A	1	Gas control rod long cotter pin.....	11

WATER PIPE UPPER

22664-A	1	Water pipe upper.....	12
87-A	1	Water pipe upper gasket.....	12
315-A	2	Water pipe upper screw.....	12
342-A	2	Water pipe upper screw lockwasher.....	12

WATER PIPE LOWER

22665-A	1	Water pipe lower.....	12
86-A	1	Water pipe lower gasket.....	12
303-A	2	Water pipe lower screw.....	12
615-A	2	Water pipe lower screw lockwasher.....	12
25017-A	1	Water pipe lower to cylinder tube.....	12
1532-A	2	Water pipe lower to cylinder tube nut.....	12
1533-A	2	Water pipe lower to cylinder tube union.....	12

Give Engine Number with Each Parts Order

COMPANION FLANGE

Part No.	No. Req.	PART NAME	Plate No.
22347-B	1	Companion flange, exhaust—threaded 1½" pipe.....	
22027-B	1	Companion flange, exhaust—2½" dia. hole—bevelled.....	15
■ 22028-A	1	Companion flange gasket—2" I. D. x2¾" O. D. ⅜" round.....	15
■ 22328-A	1	Companion flange gasket—1⅞" flat asbestos.....	
352-A	3	Companion flange screw ½"—13x1¼".....	

GASOLINE TANK

25043-CS	1	Gasoline tank with cap.....	14
5040-A	1	Gasoline tank filler cap (screw on type).....	11
29046-A	1	Gasoline tank filler cap ("easy on" type).....	
27619-AS	1	Gasoline tank strainer.....	

Strainer 27619-AS replaces the 5053-AS strainer, the new strainer has a glass sediment bulb while the 5053-AS strainer has a bronze sediment bulb.

25010-AS	1	Gasoline line (Gas tank to carburetor) with nuts.....	11
7052-A	2	Gasoline line nut.....	
25046-A	2	Gasoline tank support.....	14
315-A	4	Gasoline tank support attaching screw.....	14
300-A	4	Gasoline tank support attaching nut.....	14
342-A	4	Gasoline tank support attaching lockwasher.....	14
25044-B5	2	Gasoline tank hold down strap.....	
300-A	2	Gasoline tank hold down strap nut.....	14
342-A	2	Gasoline tank hold down strap lockwasher.....	14
190-A	2	Gasoline tank hold down strap ends.....	14
5048-A	2	Gasoline tank antisqueak.....	14
14534-A	1	Gasoline tank felt washer.....	

The following parts were not used on some units:

5077-A	1	Gasoline tank nipple 2½" long.....	12
5097-A	1	Gasoline tank nipple ⅞" long.....	12
5076-A	1	Gasoline tank coupling.....	12

FRONT GAS CONTROL AND INSTRUMENT PANEL

25023-CSY	1	Hood assembled with latch hooks and exhaust pipe bracket.....	11
25025-A	1	Cross shaft gas control.....	11
4336-A	2	Cross shaft bearing.....	11
4385-A	4	Hood to bearing screw (No. ¼"x20x¾").....	11
5034-A	4	Hood to bearing nut (No. 14"x20").....	11
628-A	4	Hood to bearing lockwasher (¼" S.A.E.).....	11
5079-A	1	Gas control lever on cross shaft.....	11
205-A	1	Cap screw for lever.....	11
628-A	1	Lockwasher for lever.....	11
25034-A	1	Gas control rod (Lever to carburetor).....	11
984-A	2	Plain washer for control rod.....	11
10-A	2	Cotter pin for control rod.....	11
878-A	1	Spring on cross shaft.....	11
1196-A	2	Plain washer on cross shaft.....	11
15-A	1	Cotter pin on cross shaft.....	11
25035-D	1	Special instrument panel.....	11
25027-A	1	Ignition ground wire (No. 16).....	
4352-AS	1	Oil gauge.....	11
1659-A	1	Oil gauge pipe elbow.....	11
4353-A	1	Oil gauge pipe clamp.....	
25024-A	1	Oil gauge pipe.....	

Give Engine Number with Each Parts Order

Equipment for Burning Kerosene

The following parts are used in place of and in addition to standard engine and power unit parts.

MANIFOLD

Part No.	No. Req.	PART NAME	Plate No.
22712-D	1	Exhaust and intake manifold.....	

HOOD

25124-DS	1	Hood assembled with latch hooks and exhaust pipe bracket.....	
----------	---	---	--

FUEL TANKS

Parts marked * are same as standard P. U. but are listed here for convenience.

25204-B	1	Gasoline tank.....	
25202-A	1	Gasoline tank clamp.....	
1865-A	1	Gasoline tank clamp screw.....	
342-A	1	Gasoline tank clamp screw lock washer.....	
5040-A	1	Gasoline tank cap (screw on type).....	
5032-A	4	Gasoline tank clamp rivet.....	
25043-C	1*	Kerosene tank.....	
5040-A	1*	Kerosene tank cap (screw on type).....	
29046-A	1*	Kerosene tank cap ("easy on" type).....	
25046-A	2*	Kerosene tank support.....	
25044-BS	2*	Kerosene tank hold down strap.....	
5048-A	2*	Kerosene tank anti-squeak.....	
315-A	4*	Kerosene tank support attaching screw.....	
300-A	4*	Kerosene tank support attaching nut.....	
190-A	2*	Kerosene tank hold down strap ends.....	
300-A	2*	Kerosene tank hold down strap nut.....	
342-A	6*	Kerosene tank lock washer.....	
14534-A	1*	Kerosene tank felt washer.....	
14534-A	1	Gasoline tank felt washer.....	

FUEL LINES AND CONNECTIONS

27619-AS	1	Fuel strainer assembly.....	
25010-AS	1	Fuel line (Strainer to Carburetor) with nuts.....	
7052-A	2	Fuel line nut.....	
5406-A	1	Three way valve.....	
5097-A	2	Pipe nipple $\frac{1}{4}$ " x $\frac{7}{8}$ " long.....	
5075-A	1	Pipe elbow $\frac{1}{4}$ ".....	
25203-AS	1	Gasoline line (From gas tank to three way valve) with nuts.....	
7052-A	2	Gasoline line nut.....	
5313-A	2	Reducing bushing $\frac{1}{4}$ " to $\frac{1}{8}$ ".....	
7060-A	2	Gasoline line union.....	

CARBURETOR

If the above parts are ordered to replace Gasoline equipment the carburetor jets must be changed to Kerosene specifications. If a new carburetor is required the Hercules Motors Corporation will furnish any information which may be desired as well as supplying the carburetor. In ordering a carburetor be sure to give engine number.

CYLINDER HEAD

Cylinder Heads suitable for use with Kerosene are as follows:

22002-D	1	Cylinder head—Model OOA.....	
22202-D	1	Cylinder head—Model OOB.....	
22734-D	1	Cylinder head—Model OOC.....	

Give Engine Number with Each Parts Order