

# INDEX

Topic Title	Page	Topic Title	Page
Air Pre-Cleaner and Air Cleaner .....	42	Periodic Service .....	11
Avoid Unnecessary Engine Idling .....	17	Preparation of Tractor for Storage .....	59
Cold Weather Engine Primer .....	44	Preparation of Tractor for Use .....	12
Cold Weather Operation .....	19	Routine Service .....	11
Driving Instructions .....	17	10-Hour Service .....	11
Electrical System .....	40	100-Hour Service .....	11
Engine Clutch and Clutch Brake .....	51	200-Hour Service .....	11
Engine Control Adjustments .....	49	400-Hour Service .....	11
Engine Cooling System .....	20	1000-Hour Service .....	11
Engine Lubrication System .....	36	Specifications of Fuel .....	8
Fuel Storage .....	9	Specifications of Lubricants .....	7
Fuel System .....	22	Starting and Stopping of Engine .....	15
General Description .....	4	Steering Brakes .....	56
General Specifications .....	5	Steering Clutches .....	54
Governor .....	34	Track and Track Idler Adjustment .....	58
Operating Controls and Instruments .....	13	Tractor and Engine Serial Number .....	6
Operating in Mud or Water .....	19	Valve Adjustment and Cylinder Head .....	46
Periodic Adjustment .....	11		
Periodic Lubrication and Preventive Maintenance .....	10		

# GENERAL DESCRIPTION

The Model "HD 6B" Tractor is a 12,400 pound track-type tractor powered with a 4 cylinder, 4 cycle "DIESEL" engine.

Power from the engine is transmitted through a single plate, over-center type engine clutch to the transmission through a universal joint drive shaft assembly. From the transmission the power is transmitted to the bevel gear and from the bevel gear through the steering clutches to the final drives and the track drive sprockets.

The transmission provides 5 forward speeds ranging from 1.5 M.P.H. in low gear to 5.5 M.P.H. in high gear and a reverse speed of 2.0 M.P.H., under full governed engine speed of 1800 R.P.M.

Mechanical self-energizing brakes, wide operator's seat, and unobstructed view of the front of both tracks assure easy, positive control of the tractor at all times.

The standard model tractor is equipped with 24-volt electric starting and light equipment, suction type cooling fan, muffler, full width crankcase guard, bumper, hinged radiator guard, and 13" grouser track shoes. The truck wheels, track idlers, and track support rollers have positive type seals.

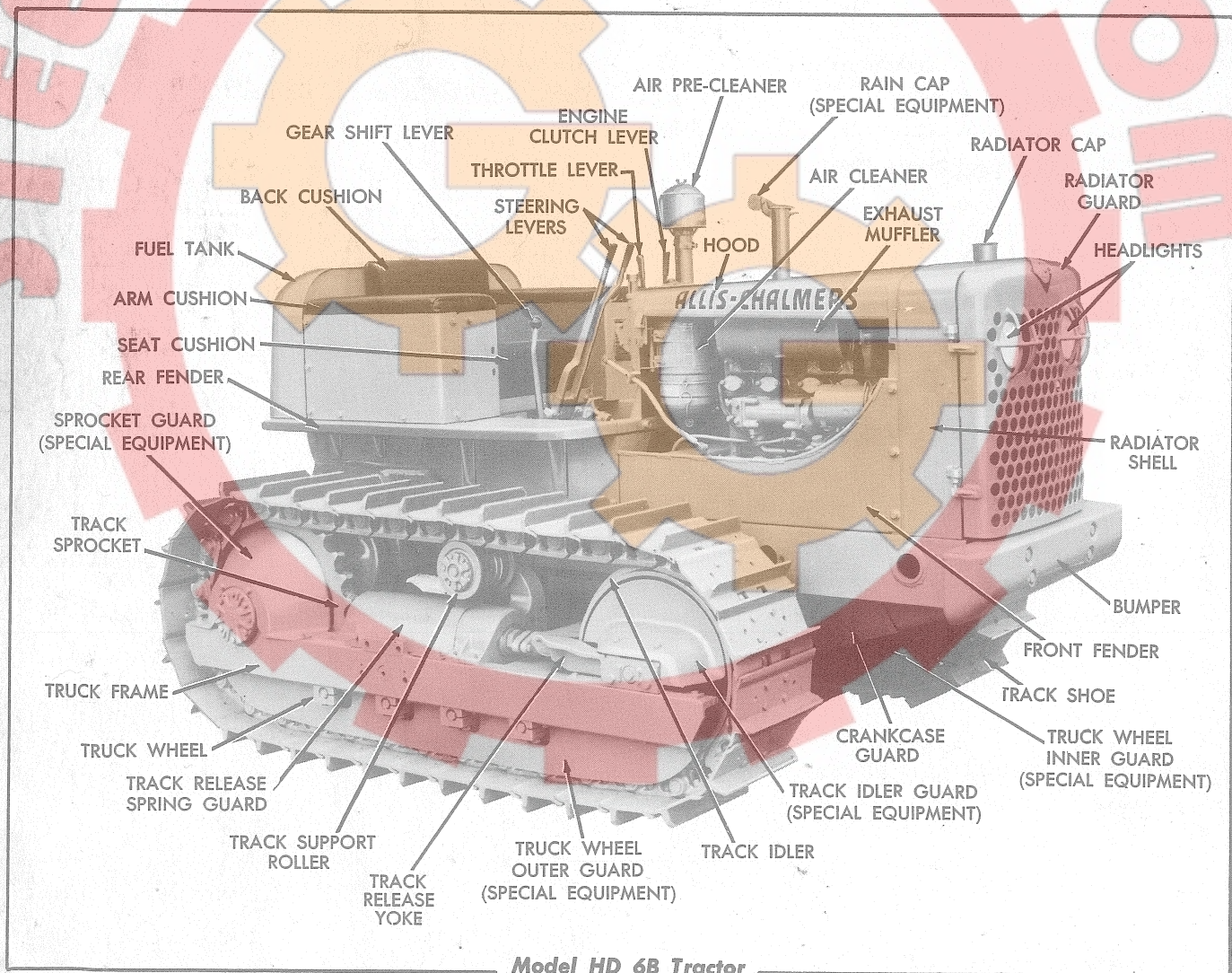

FIG. 1

# GENERAL SPECIFICATIONS

## (STANDARD TRACTOR)

### General Dimensions and Weight:

Overall Length ..... 10 ft. 7 $\frac{1}{2}$  in.  
 Overall Height (to top of exhaust stack) ..... 5 ft. 8 $\frac{3}{8}$  in.  
 Overall Width (standard shoes) ..... 6 ft. 6 $\frac{3}{4}$  in.  
 Ground Clearance ..... 11 $\frac{1}{4}$  in.  
 Drawbar Height (center line of jaw) ..... 13 $\frac{1}{8}$  in.  
 Lateral Drawbar Movement ..... 21 in.  
 Shipping Weight (approximate) ..... 12,400 lbs.

### Tracks:

Width of Standard Track Shoes ..... 13 in.  
 Maximum Width Track Shoes Available ..... 20 in.  
 Tread Width (center-to-center) ..... \* 60 in.

### Engine:

Make ..... "Allis-Chalmers" Diesel  
 Model ..... HD-344  
 Type ..... 4 Stroke Cycle  
 (Naturally Aspirated)  
 Number of Cylinders ..... 4  
 Bore ..... 4 $\frac{1}{8}$  in.  
 Stroke ..... 5 $\frac{1}{8}$  in.  
 Crankshaft Rotation (when viewed  
 from fan end) ..... Clockwise  
 Number of Main Bearings ..... 5  
 Piston Displacement ..... 344 cu. in.  
 Lubrication ..... Pressure  
 Fuel Used ..... Diesel Fuel  
 Fuel Supplied By.. "American Bosch" Fuel Injection Pump  
 Low Idle Speed ..... 525 to 550 R.P.M.  
 High Idle Speed ..... 1930 R.P.M. + or - 25  
 Governed at Full Load ..... 1800 R.P.M.

### Steering:

Method ..... Clutches  
 Controls ..... Mechanical  
 Turning Radius ..... 84 $\frac{1}{4}$  in.

### Capacities (Approximate): (U. S. Standard Measure)

Cooling System ..... 6 $\frac{1}{2}$  gals.  
 Crankcase and Filter ..... 2 $\frac{1}{2}$  gals.  
 Air Cleaner ..... 2 qts.  
 Transmission ..... 5 gals.  
 Final Drives (each) ..... 3 gals.  
 Fuel Tank ..... 40 gals.  
 Support Roller (each) (Grease) ..... 1 lb.  
 Truck Wheel (each) (Grease) .....  $\frac{7}{8}$  lb.  
 Track Idler (each) (Grease) ..... 1 $\frac{1}{2}$  lbs.

### Speeds (at Rated Engine Speed):

	HD 6B	HD 6G
1st Gear.....	1.5 M.P.H.	1.5 M.P.H.
2nd Gear.....	2.4 M.P.H.	2.4 M.P.H.
3rd Gear.....	3.3 M.P.H.	3.3 M.P.H.
4th Gear.....	4.0 M.P.H.	5.5 M.P.H.
5th Gear.....	5.5 M.P.H.	-----
1st Reverse.....	2.0 M.P.H.	2.0 M.P.H.
2nd Reverse.....	-----	4.1 M.P.H.

*The Allis-Chalmers Manufacturing Company reserves the right to make changes in the above specifications or to add improvements at any time without notice or obligation.*

## TRACTOR AND ENGINE SERIAL NUMBERS

On all parts orders and in all correspondence relative to the tractor, it is necessary that both the tractor and engine serial numbers be given. This will properly identify the particular tractor and will assure obtaining the correct replacement parts for it.

The tractor serial number is stamped in the rear face of the steering clutch housing (near the upper right corner) and is also stamped on a serial number plate attached to the cowl.

The engine serial number is stamped on a plate attached to the left rear side of the cylinder block.

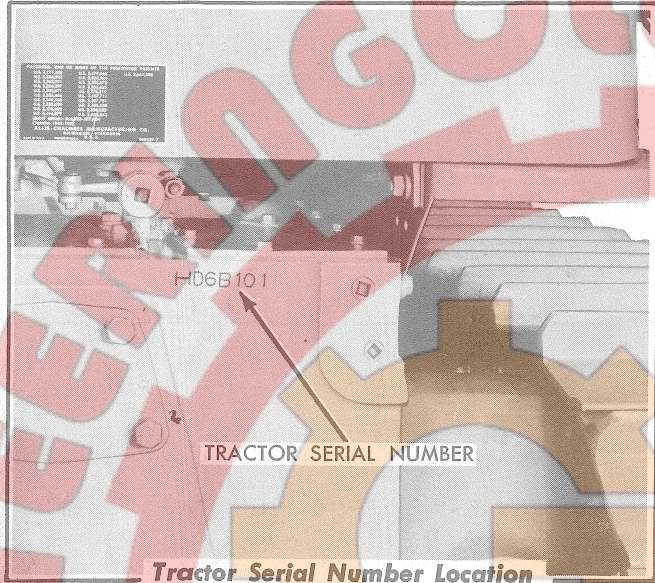

FIG. 2

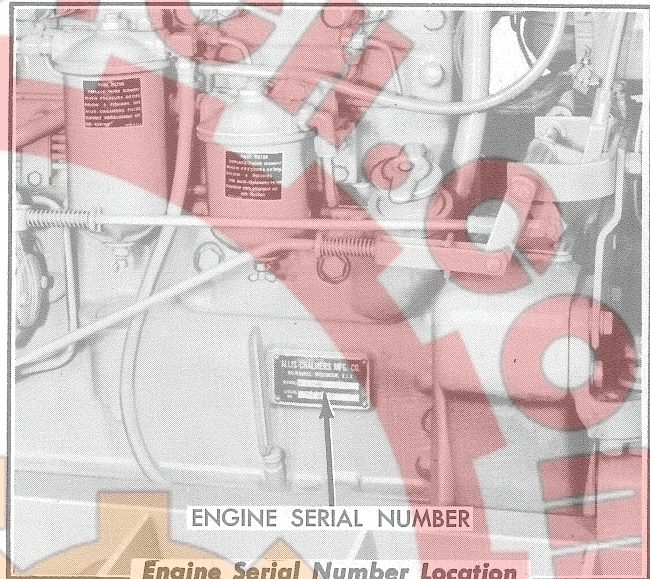

FIG. 3

## SPECIFICATIONS OF LUBRICANTS

### A. Engine Crankcase Lubricant

USE NON-CORROSIVE "DIESEL" ENGINE LUBRICATING OIL CONTAINING ADDITIVES WHICH WILL PREVENT SLUDGE OR GUM DEPOSITS. UNDER NO CIRCUMSTANCES SHOULD A CORROSIVE ENGINE LUBRICATING OIL EVER BE USED.

Use oils of the following viscosities:

Atmospheric Temperature	Viscosity
90° F. and above	Use SAE 40
32° F. to 90° F.	Use SAE 30
0° F. to 32° F.	Use SAE 20W
0° F. and below	Use SAE 10W

Manufacturers of lubricants recognize the importance of the qualities required for use in our equipment and they are cooperating fully to assure the use of only those oils which fulfill these requirements. The oil distributor and oil manufacturer are to be held responsible for the results obtained from their products.

The outstanding lubricating requirements for efficient operation of the engine are: The maintaining of piston rings in a clean, free condition; absence of hard carbon and "varnish" deposits on or within engine parts; the prevention of bearing corrosion; and the promotion of general cleanliness within the engine.

Proper operation and maintenance of the engine are necessary to obtain the desired results from the lubricating oil.

### B. Air Cleaner

Use the same viscosity oil in the air cleaner as used in the engine crankcase. CAUTION: Do not use an oil that foams.

### C. Transmission and Final Drive Lubricant

Lubricate these assemblies with a good grade of engine lubricating oil purchased from a reputable oil company.

Use oils of the following viscosities:

Atmospheric Temperature	Viscosity
Above 32° F.	Use SAE 50
32° F. and below	Use SAE 30

### D. Truck Wheel, Track Idler, and Track Support Roller Lubricant

Lubricate these assemblies with a grease that has been tested and found satisfactory for use by the Allis-Chalmers Manufacturing Company.

A revised list of approved greases is issued periodically. Ask your nearest "Allis-Chalmers" authorized Dealer for the latest list.

### E. Pressure Gun Lubricant

Use a ball and roller bearing lubricant with a minimum melting point of 300° F. This lubricant should have a viscosity range so as to assure easy handling in the lubricating gun at the prevailing atmospheric temperature, and MUST be water-proof.

## SPECIFICATIONS OF FUEL

The "DIESEL" fuel should be a natural distillate petroleum oil and must have certain qualities in order to ignite and burn at the proper rate and temperature. Field experience has shown that the fuel best suited for this engine closely approximates the following specifications:

Gravity API .....	30 — 35
Viscosity Saybolt Universal at 100° F. . . . .	35 — 40
Flash Point .....	150° F.
Diesel Index .....	48.5 to 65.5
Cetane Number .....	46 to 60
Pour Point .....	0° F.
Volatility 90% .....	650° F. Max.
End Point 98%	
Summer .....	700° F. Max.
Winter .....	600° F. Preferable
Sediment and Water .....	Trace
Ash .....	.02 of 1% Max.
Conradson Carbon .....	.03 of 1% Max.
Sulphur .....	½ of 1% Max.

For satisfactory fuel flow through lines and filters in cold weather, the pour point of the fuel must be at least 10° F. below the prevailing atmospheric temperature.

The API gravity of a fuel varies with its specific gravity. The low API fuels are desirable because they have a high specific gravity and more heat units per gallon. However, the higher the API gravity, the better will be the ignition quality of the fuel.

The ignition quality of a fuel is expressed as a "cetane number." The higher the cetane number, the higher the quality of the fuel. The higher cetane

fuel shortens the ignition delay period to facilitate starting and improve combustion. The "DIESEL" index number, which is a close approximation of the cetane number, is a field method to represent ignition quality.

The distillation 90% point and the end point are important. High volatility is required to enable complete vaporization of the fuel, clean combustion, and low residue formation.

The flash point of a fuel has no quality significance, but is important with respect to safety in storage and handling of the fuel.

It is important that the fuel be within the specified limits for ash, carbon, water, and sediment content, etc., to prevent excessive wear and damage to engine parts.

It is also important that the fuel has lubricating properties so that the fuel injection pump and fuel nozzles are adequately lubricated. At times it may be necessary to use fuel with no lubricating properties. If this occasion arises, add one quart of SAE 10 engine oil to every 10 gallons of fuel. *NOTE: Distillates should be used only in emergencies. When the proper fuel is again available, the fuel system must be drained and cleaned before the proper fuel is added.*

**CAUTION:** *The sulphur content of "DIESEL" fuel should be as low as possible. The fuel should not contain a sulphur content of more than ½ of 1%.*

Generally speaking, a No. 2 "DIESEL" fuel purchased from a reputable oil company will meet the above specifications.

## FUEL STORAGE

The importance of proper storage of fuel cannot be too strongly stressed. Storage tanks, drums, or service tanks must be free from rust, scale, sediment, or any other foreign matter which will contaminate the fuel. Contaminated fuel will clog the engine fuel filters and eventually damage the fuel injection pump and fuel nozzles.

A portable storage tank provides the best method for storing fuel on the job. In such a tank, the sediment and water can easily be drained and the fuel can be pumped into the tractor fuel tank with a minimum of handling. Consult your nearest "Allis-Chalmers" Dealer for details about this type of storage tank. Since condensation will occur in the storage tank, it is very important that a sediment sump be provided in the bottom of the tank, so that water and sediment can be drained daily.

Fuel should be allowed to settle at least 48 hours in a storage container before it is added to the

fuel tank of the tractor. It is advisable to use a pump and draw the fuel from the storage tank, or barrel, rather than to drain it from the bottom of the fuel container. Where conditions are such that drums must be used to supply fuel, it is advisable to have enough drums to allow sufficient time for the fuel to settle. The fuel thus left in a number of drums can be collected into one drum and used after the usual time allowed for settling. In this manner, the sediment and foreign matter will be disposed of and no fuel will be wasted. Whenever drums are used for fuel storage, they should be covered or placed under shelter so that the fuel will not become contaminated by water, which will enter through the filler plugs when it rains, even though the plugs are tight.

The fuel tank of the tractor should be filled at the end of the day's run rather than at the start; this will reduce the water content, as a full tank is less subject to condensation.

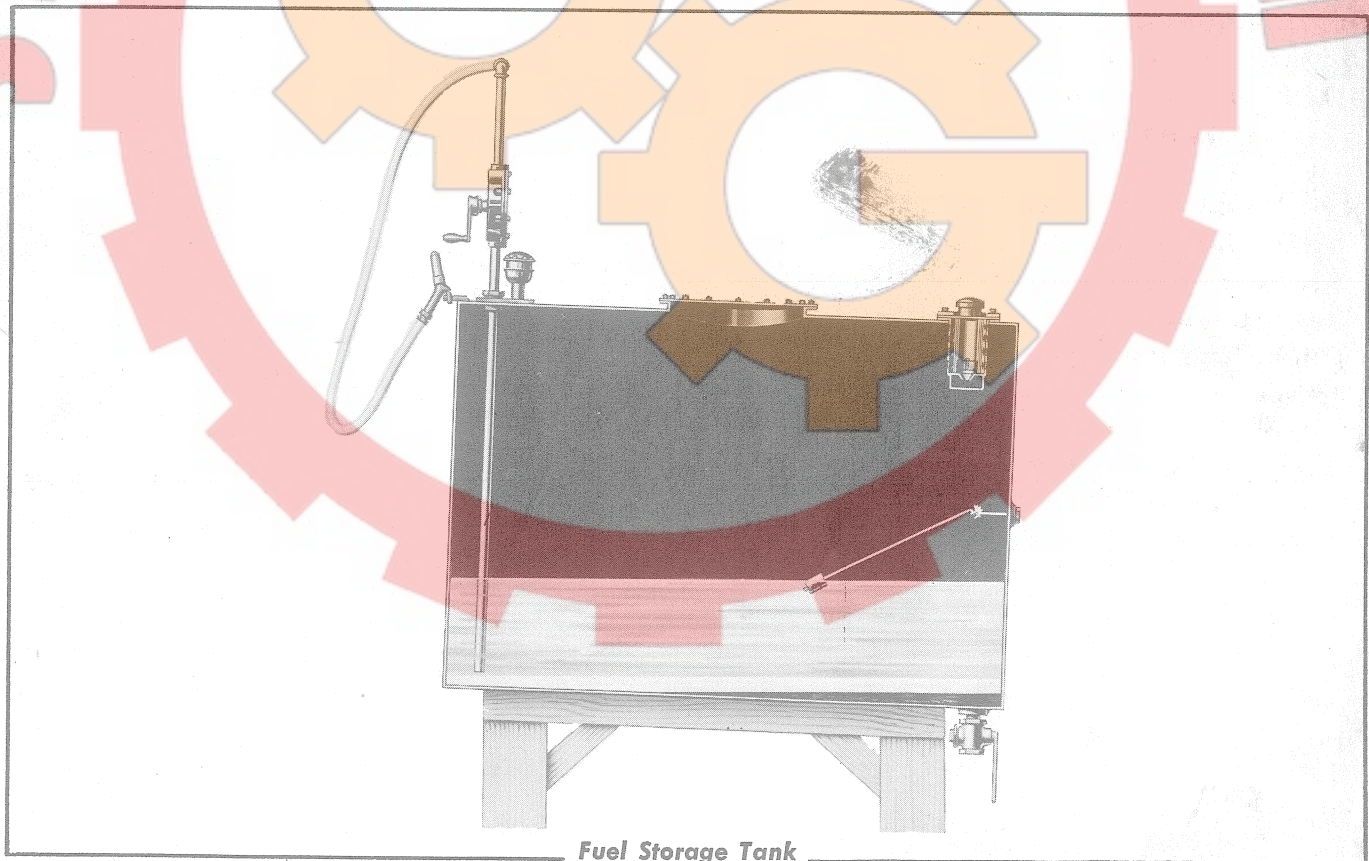

Fuel Storage Tank

FIG. 4

## PERIODIC LUBRICATION AND PREVENTIVE MAINTENANCE

Lubrication is an essential part of preventive maintenance, controlling to a great extent the useful life of the tractor. Different lubricants are needed and some components in the tractor require more frequent lubrication than others. Therefore, it is important that the instructions regarding types of lubricants and the frequency of their application, as given in this manual and on the "LUBRICATION CHART," be explicitly followed. Periodic lubrication of the moving parts reduces to a minimum the possibility of mechanical failures.

To prevent minor irregularities from developing

into serious conditions that might involve shut-down and major repair, several other services are recommended for the same intervals as the periodic lubrication. The purpose of these services or inspections, which require only a few minutes, is to assure the uninterrupted operation of the tractor by revealing the need for adjustment caused by normal wear. The need for some minor adjustment, if neglected, could result in failure and shut-down. Refer to the "LUBRICATION CHART" for relative location of the service points of the tractor to be serviced.

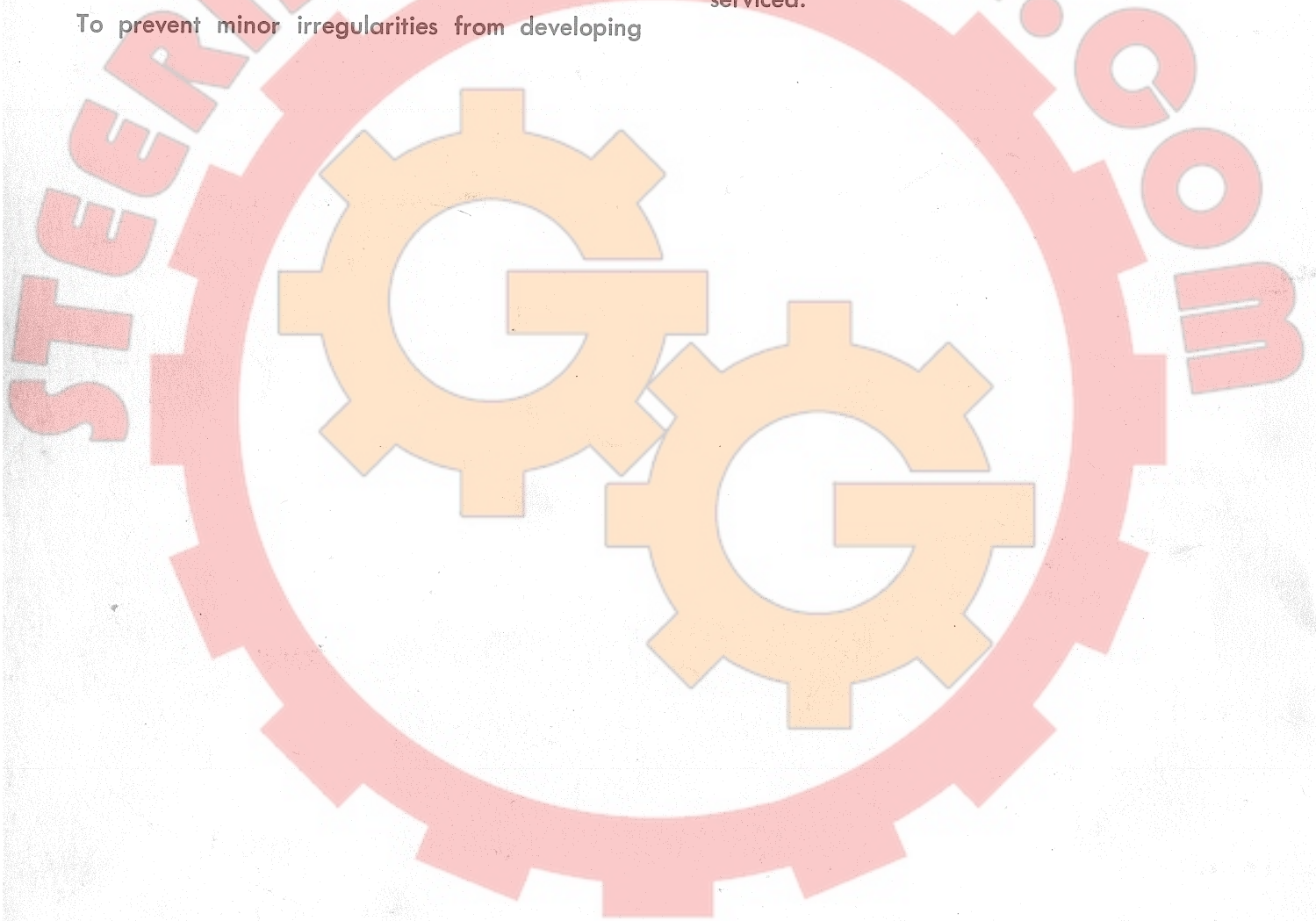



## ROUTINE SERVICE

For added convenience, listed below are the lubrication points, adjustments, service items, and inspections to be made at each of the intervals (10 — 100 — 200 — 400 — 1000 hours) shown on the "LUBRICATION CHART." Reference symbols given below refer to those given on this chart.

### 10-HOUR SERVICE

(Identified by ○ on chart)

#### INSPECT:

Engine Crankcase — Oil Level  
Air Cleaner Oil Cup — Oil Level  
Air Pre-Cleaner — Dust Level  
Radiator — Coolant Level  
Batteries — Check Electrolyte Level

#### SERVICE:

Fuel Filters  
First Stage — Drain Sediment  
Second Stage — Drain Sediment  
Fuel Tank — Check Fuel Level and Drain Sediment

#### LUBRICATE:

Engine Clutch Shifting Bearing

### 100-HOUR SERVICE

(Identified by □ on chart)

#### INSPECT:

Final Drives — Oil Level  
Transmission — Oil Level

#### SERVICE:

Engine Crankcase — Change Oil  
Lubricating Oil Filter — Replace Element  
Batteries — Test with Hydrometer

#### LUBRICATE:

Engine Clutch Shaft Rear Bearing  
Engine Clutch Camshafts ("Rockford" Clutch only)  
Engine Clutch Shifting Sleeve

### 200-HOUR SERVICE

(Identified by ● on chart)

#### LUBRICATE:

Fan Idler Bearings  
Fan Bearings  
Generator  
Brake Pedal Levers

### 400-HOUR SERVICE

(Identified by ⊛ on chart)

#### LUBRICATE:

Drive Shaft Universal Joints

### 1000-HOUR SERVICE

(Identified by ■ on chart)

#### LUBRICATE:

Truck Wheels  
Truck Idlers  
Track Support Rollers

#### SERVICE:

Transmission — Change Oil  
Final Drives — Change Oil

### PERIODIC SERVICE

Fuel Filters — Replace Elements  
Cooling System — Drain and Flush  
Fuel Tank — Drain and Flush

### PERIODIC ADJUSTMENT

Engine Clutch — Check and Adjust  
Steering Clutch Linkage — Check and Adjust  
Brakes — Check and Adjust  
Tracks — Check and Adjust  
Water Pump and Generator Belt — Check and Adjust  
Fan Belts — Check and Adjust  
Valve Tappet Clearance — Check and Adjust  
Fuel Nozzles — Check and Adjust

## PREPARATION OF TRACTOR FOR USE

Make a complete inspection of the tractor to make sure that no parts have been lost or damaged while in transit or storage.

Fill the fuel tank with the specified fuel (refer to "SPECIFICATIONS OF FUEL"). Use care to prevent the entrance of dirt or foreign matter while filling the tank. Fill the engine cooling system with clean soft water or a suitable anti-freeze solution (refer to "ENGINE COOLING SYSTEM").

Check the oil level in the engine crankcase, transmission, and final drive compartments. Lubricate the engine fan and all points where lube fittings are provided for use of a lubricating gun. Be sure the truck wheels, track idlers, and track support rollers are completely filled with the specified lubricant (refer to "LUBRICATION CHART").

Remove the oil cup from the bottom of the air cleaner and check to be sure the oil in the cup is at the proper level. Make certain the air pre-cleaner is properly installed (refer to "AIR PRE-CLEANER AND AIR CLEANER").

**NOTE:** *To minimize movement of the tractor on its blocking while in transit, the tracks were purposely adjusted "TIGHT" at the factory. Before unloading the tractor from its carrier, the tracks must be properly adjusted (refer to "TRACK AND TRACK IDLER ADJUSTMENT").*

Operate the tractor with a light load for the first 60 hours. The most efficient engine operation is obtained with the engine coolant temperature held within a range of 160° to 185° F. Operating the engine with the coolant temperature below this range will result in incomplete combustion of fuel, higher fuel consumption with less power, and will

cause harmful gummy deposits within the engine. Maintaining the correct engine coolant operating temperature depends mostly on proper functioning of the thermostats. If the engine coolant operating temperature remains consistently below normal, the thermostats should be removed, checked for proper operation, and replaced if necessary.

When operating in cold weather, provide a cover for the sides of the engine compartment if the thermostats prove inadequate to maintain a normal operating coolant temperature of 160° to 185° F.

Inspect the entire tractor after the first 10 hours of operation. Tighten all loose bolts and check the adjustment of the engine clutch, steering clutch linkage, brakes, and tracks. Tighten all track shoe bolts; by tightening these bolts at this time and again at the end of 60 hours, the possibility of their becoming loose and enlarging the bolt holes will be minimized.

**IMPORTANT:** *THE TIGHTNESS OF THE CYLINDER HEAD STUD NUTS MUST BE CHECKED AT LEAST TWO (2) TIMES AFTER A NEW ENGINE OR A REBUILT ENGINE HAS BEEN PLACED IN OPERATION. THE CHECKS MUST BE MADE AFTER THE FIRST 10 AND 100 HOURS OF OPERATION. If the cylinder head stud nuts are not maintained at the correct torque (95 to 105 lbs. ft. torque on the 1/2", and 160 to 180 lbs. ft. torque on the 5/8" cylinder head stud nuts), it is possible that cylinder head gasket trouble will be encountered. After the cylinder head stud nuts have been checked for proper torque, it is also necessary to check the valve tappets for proper clearance (refer to "VALVE ADJUSTMENT AND CYLINDER HEAD" for detailed information).*

## OPERATING CONTROLS AND INSTRUMENTS

The operator of the tractor must familiarize himself with the various controls and the instruments provided for its operation. Although many of these controls are similar to those of other tractors, there are important differences, and it is not wise regardless of previous experience, to operate the tractor before fully understanding the purpose of each control and instrument.

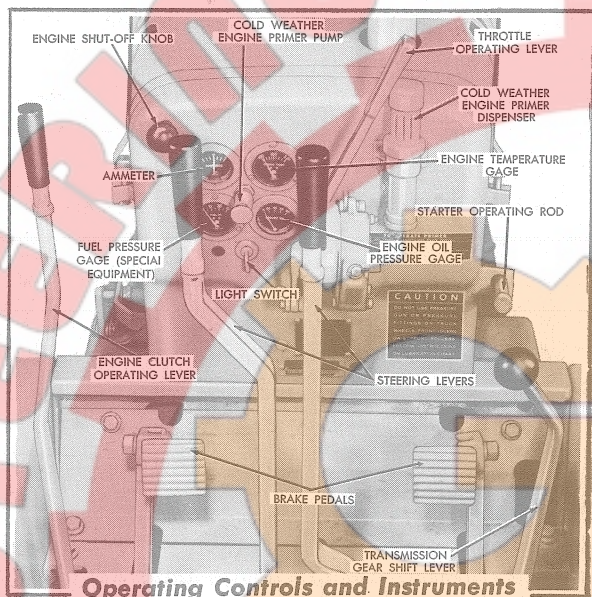

FIG. 5

### A. OPERATING CONTROLS

**1. Engine Shut-Off Knob.** The engine shut-off knob is provided to actuate the engine shut-off control lever, located in the fuel injection pump. Push the engine shut-off knob all the way forward when the engine is to be started; pull the knob all the way back to stop the engine. **CAUTION:** Do not stop the engine without first slowing the engine to idling speed. The engine should be slowed to idle speed and allowed to cool at least 5 minutes before stopping.

**2. Starter Operating Rod.** Push on the starter operating rod to engage the starter pinion with the flywheel ring gear and to operate the starter switch. Each time the starter operating rod is depressed it must be allowed to return to its original position (all the way back) and the starter given time to cease spinning before the starter can again be used; otherwise, the starter will spin and will not crank the engine. **NOTE:** If the engine does not start within 30 seconds allow the starter to cool for 2 minutes before using it again (refer to

"STARTING OF ENGINE"). As a safety precaution, a hole is provided in the starter operating rod so that a lock may be inserted to prevent starting the engine when the tractor is parked or stored.

**3. Throttle Operating Lever.** The throttle operating lever is connected to the speed control lever of the governor. The engine will run at idling speed with the throttle operating lever all the way forward; pull the lever back to increase the engine speed as desired.

**4. Engine Clutch Operating Lever.** The engine clutch operating lever controls the engine clutch which transmits power from the engine to the transmission. Push the lever forward to disengage the clutch; pull it back to engage the clutch.

**5. Transmission Gear Shift Lever.** The transmission gear shift lever is used to select the proper transmission gear ratio for the desired power or speed. The position to which the lever must be moved for each of the forward speeds and the reverse speed is indicated on the gear shifting instruction plate attached to the base of the cowl.

The engine-clutch operating lever also actuates a shifting shaft locking device in the transmission. When the clutch operating lever is pulled back to engage the clutch, it locks the transmission shifting shafts in the position to which they have been moved by the transmission gear shift lever. The engine clutch operating lever must be moved to the disengaged position before the transmission gear shift lever can be moved into neutral or into another position.

**6. Steering Levers.** The steering levers control two steering clutches which connect the transmission with the final drive gears and track drive sprockets. These levers are used to steer the tractor by disengaging the left or right steering clutch. Pull the right-hand steering lever back to make a right turn; pull the left-hand steering lever back to make a left turn (refer to "DRIVING INSTRUCTIONS").

**7. Brake Pedals.** The brake pedals are used to retard the speed or to facilitate turning the tractor. To turn the tractor to the right, fully disengage the right steering clutch and press on the

right brake pedal; to turn the tractor to the left, fully disengage the left steering clutch and press on the left brake pedal. After the desired turn has been made, release the brake pedal and return the steering lever to its forward position.

**CAUTION:** Never attempt to use the brakes to turn the tractor without first pulling the steering lever back as far as possible on the side toward which the turn is to be made.

**8. Parking Brake Lock Levers.** The parking brake lock levers provide a means of holding the brake pedals in the applied position. To engage the parking brake lock levers, depress the brake pedals and move the lock levers forward. To disengage the parking brake lock levers, further depress the brake pedals and move the lock levers toward the rear.



FIG. 6

**9. Cold Weather Engine Primer Dispenser.** The primer dispenser, located on the cowl (to the right of the instruments), is used to hold and to puncture a capsule containing starting fluid used as an aid in starting the engine in cold weather.

**10. Cold Weather Engine Primer Pump.** The primer pump, mounted in the cowl with the instruments, is used to force starting fluid through a small nozzle and into the air inlet elbow of the engine. Refer to "STARTING OF ENGINE" for full instructions on the use of the Cold Weather Engine Primer Pump and Primer Dispenser.

**11. Light Switch.** Move the switch lever to turn on the lights.

## B. INSTRUMENTS

**1. Engine Temperature Gage.** This gage indicates the engine coolant operating temperature, which should be maintained between 160° and 185° F. at all times.

**2. Engine Oil Pressure Gage.** This indicates the pressure at which the engine lubricating oil is circulated through the engine. At full throttle, the oil pressure should be between 30 and 55 pounds at normal engine operating temperature (160° to 185° F.). **CAUTION:** If no oil pressure is indicated by the gage, the engine must be stopped immediately and the cause determined and corrected.

**3. Fuel Pressure Gage (Special Equipment).** This gage indicates the pressure at which the fuel is circulated through the low pressure fuel system. Under normal conditions, with the engine operating at full governed speed, the fuel pressure should be between 5 and 15 pounds.

**4. Ammeter.** The ammeter indicates the charging rate of the generator. When the batteries are in a discharged condition, the ammeter should indicate a good rate of charge until the batteries approach a fully charged condition. When the batteries are fully charged, the ammeter will indicate nearly zero except for a short time after the starter has been used.

**5. Engine Hour Meter.** The engine hour meter is installed as special equipment.

All hands of the hour meter move clockwise. The small indicator (upper left) visibly turns when the meter is recording. The meter records up to 10,000 hours and repeats. The four figures of the hours of operation are read from the three hands as follows:

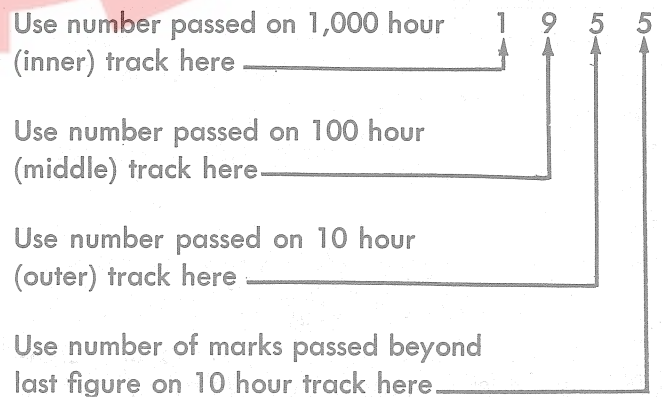

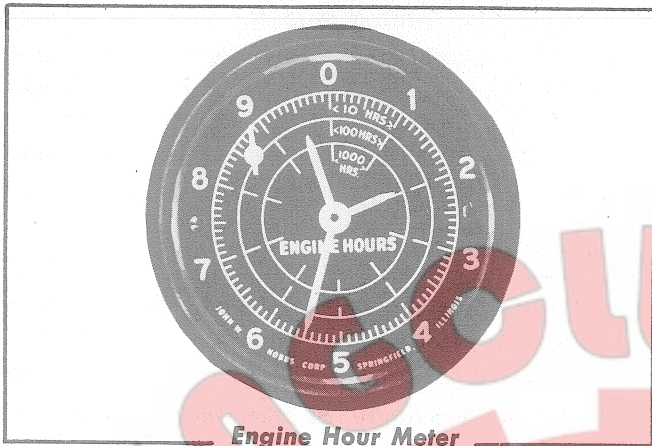

**Engine Hour Meter**  
(Reading — 1955 Hours)

FIG. 7

## STARTING AND STOPPING OF ENGINE

### A. Starting of Engine

1. Before starting the engine, check the fuel level, crankcase oil level, and the level of the water or anti-freeze solution in the cooling system. If repairs have been made since the last operating period, be sure that all nuts and bolts affected by the repairs have been tightened and the parts have been properly adjusted.
2. Push the engine clutch operating lever forward and move the transmission gear shift lever to its neutral position.
3. Push the engine shut-off knob all the way forward (run position).
4. Pull the throttle operating lever all the way back (high idle).
5. Press forward on the starter operating rod. If the starter spins but does not crank the engine, pull the starter operating rod back to its original position (all the way back) and wait until the starter stops spinning before depressing the rod again. **CAUTION:** *If the engine does not start within 30 seconds, allow the starter to cool for 2 minutes before using it again.*
6. As soon as the engine starts, push the throttle operating lever forward enough to slow the engine to about  $\frac{1}{2}$  of full speed and allow the engine to warm up. **CAUTION:** *Be sure*

*the engine clutch operating lever is in the engaged position during the engine warm up period.*

7. Observe the engine lubricating oil pressure indicated by the gage. With the engine running at full speed and with the engine coolant at normal operating temperature ( $160^{\circ}$  to  $185^{\circ}$  F.), the oil pressure should be between 30 and 55 pounds. If the oil is cold, no pressure may be indicated by the gage for about 15 seconds after the engine starts, but if the pressure does not then rise to normal or above, the engine must be stopped immediately and the cause determined and corrected.
8. If the tractor is equipped with a fuel pressure gage (Special Equipment), observe the fuel pressure indicated by the gage. With the engine running at full speed, the fuel pressure should be between 5 and 15 pounds.
9. Move the throttle operating lever to obtain the desired engine speed.
10. In cold weather, when it is necessary to use a starting aid in starting the engine, proceed as stated above in the first four (4) operations, then proceed as follows:
  - a. Unscrew the upper chamber of the engine primer dispenser.
  - b. Place a capsule of starting fluid, small

or large, depending upon the atmospheric temperature and the requirements established by trial, in the lower chamber or body of the primer dispenser. In extremely low temperatures, one large and one small capsule may be necessary.

- c. Pull the plunger to the top of the upper chamber and screw the upper chamber tightly onto the primer dispenser body.
- d. Push the plunger to the bottom, thereby puncturing the capsule and releasing the starting fluid so it can be picked up by the primer pump.
- e. Push the engine shut-off knob all the way forward (run position) and pull the throttle operating lever all the way back (high idle position).
- f. Depress the starter operating rod to crank the engine, and at the same time operate the primer pump to force starting fluid into the engine air intake system. Continue pumping, after the engine starts, until all of the starting fluid in the dispenser has been injected into the air intake system. **CAUTION: ALWAYS BE SURE THE STARTER IS CRANKING THE ENGINE BEFORE USING THE PRIMER PUMP TO INJECT STARTING FLUID INTO THE ENGINE AIR INTAKE SYSTEM.**
- g. While the engine is warming up, unscrew the upper chamber of the engine primer dispenser, remove the empty capsule, and reinstall the upper chamber.

**CAUTION:** *The starting fluid contained in the capsule is essentially ethyl ether, highly inflammable*

*and should be treated with the same caution as high octane gasoline. Gelatine capsules dissolve in water and soften at high temperatures. Therefore, the following precautions must be taken:*

1. Avoid breathing large quantities of the fumes from the starting fluid.
2. Avoid cutting of the hand by barbs on the puncturing plunger.
3. Avoid proximity of the starting fluid and capsules to open flames, sparks, or hot surfaces.
4. Avoid contact of the capsules with water.
5. Avoid subjection of the capsules to high temperatures (above approximately 120° F.).

Obtain starting fluid capsules from your nearest "Allis-Chalmers" Construction Machinery Dealer. The capsules are packed, 12 of the 17 c.c. or 24 of the 7 c.c. sizes, in a can for safe storage and handling. Obtain the size and quantity most suitable for your needs according to the prevailing atmospheric temperature.

### **B. Stopping of Engine**

Push the throttle operating lever all the way forward (low idle position) and allow the engine to idle for at least 5 minutes, so that the engine may cool gradually and uniformly, then pull the engine shut-off knob all the way back to stop the engine. **IMPORTANT: ALWAYS SLOW THE ENGINE TO IDLING SPEED BEFORE PULLING THE ENGINE SHUT-OFF KNOB TO STOP THE ENGINE.** Cover the exhaust pipe at the end of each day's operation to prevent rain from entering while the tractor is idle.

## AVOID UNNECESSARY ENGINE IDLING

Prolonged engine idling causes the engine coolant temperature to fall below the specified operating range of 160° to 185° F. Operating with the coolant temperature below this range is detrimental to the engine, causing incomplete combustion of fuel, which in turn causes crankcase dilution and lacquer or gummy deposits to form

on valves, pistons, rings, etc. It also causes rapid accumulation of sludge within the engine.

Since starting the engine is readily accomplished with an electric starter, there should be no reason for prolonged engine idling. Stop the engine when prolonged idling periods are necessary.

## DRIVING INSTRUCTIONS

### A. Starting of Tractor

Start the engine and allow it to warm up, then slow the engine to idling speed. If the engine clutch has been engaged, disengage it and push forward on the clutch operating lever to force the clutch brake facing against the brake disc, thus stopping the rotation of the transmission input shaft. Move the transmission gear shift lever into the required position for the desired speed or power. Pull the throttle operating lever about half-way back and pull back steadily on the engine clutch operating lever until all slack is taken up between the tractor and the load, then pull the lever back quickly to fully engage the clutch. After the engine clutch is engaged, move the throttle operating lever to meet the operating requirements. Engagement of the engine clutch with the engine running at half throttle and starting the load in the above manner will prevent excessive slippage of the clutch, thus prolonging clutch life. It will also prevent "shock loading" the tractor.

To shift to another speed range, push the engine clutch operating lever forward and shift for the desired speed or power. When the engine clutch operating lever is pushed forward it forces the clutch brake facing against the brake disc, thus stopping the rotation of the transmission input shaft. Stopping the input shaft rotation enables the operator to shift without clashing the gears.

To shift to a higher gear after the tractor is in motion, push the throttle operating lever forward to the idle position and disengage the engine clutch. At the same time, shift to the higher gear, engage the engine clutch, and pull the throttle lever back to obtain the desired speed.

The engine clutch operating lever controls the

engine clutch which transmits power from the engine to the transmission. Push the lever forward to disengage the clutch; pull it back to engage the clutch. The clutch operating lever also actuates a shifting shaft locking device in the transmission. When the clutch operating lever is pulled back to engage the engine clutch it locks the transmission shifting shafts in the position to which they have been moved by the transmission gear shift lever. The clutch operating lever must be moved to the disengaged position before the transmission gear shift lever can be moved to shift the gears into neutral or into another position.

Satisfactory and efficient operation depends largely on the operator's judgment in selecting the proper gear ratio and speed for the various loads or operation. Always operate the tractor in the speed range that will permit the engine to operate at full speed. This will not only assure the most power from the engine but will also allow the engine to operate at its highest efficiency. **CAUTION: DO NOT SLIP THE ENGINE CLUTCH IN AN EFFORT TO PULL AN OVERLOAD; SHIFT TO A LOWER GEAR.**

The engine clutch should engage with a definite over-center "snap" and should require an appreciable pull on the operating lever for its engagement. If this "snap" is not evident, or if the clutch slips when under a load, adjustment must be made immediately (refer to "ENGINE CLUTCH ADJUSTMENT").

### B. Steering of Tractor

The tractor is steered by disengaging the steering clutch on the side of the tractor toward which the turn is to be made. This is done by using the steer-

ing levers located directly in front of the operator. To make a right turn, pull back the right-hand steering lever; to make a left turn, pull back the left-hand steering lever. With the left steering clutch disengaged, power is not delivered to the left track and the track will slow down or stop. Since power is still being delivered to the right track, the right track will keep turning and cause the tractor to turn to the left. When the right steering clutch is disengaged, the tractor will turn to the right in a similar manner.

If a short turn is to be made, pull the steering lever back on the side toward which the turn is to be made and press down on the corresponding brake pedal; this will stop the track completely. Always pull the steering lever all the way back when turning. When the tractor has turned as desired, return the lever immediately to its forward position. Disengage and engage the steering clutches smoothly and completely to avoid excessive wear on the clutch friction discs.

When steering the tractor down steep grades with the load pushing the tractor, the use of the steering levers is opposite to that when pulling a load. In this case, the left-hand steering lever is used to make a right turn and the right-hand steering lever to make a left turn. Disengaging either steering clutch will allow the track on that side to travel faster, since the braking power of the engine is released from it, while the steering clutch remaining engaged will act as a brake for the opposite track.

During operation, observe the amount of free travel of the steering levers (the distance the levers move before pressure is felt and disengagement of clutch begins). This free travel, which assures complete engagement of the steering clutches, should be from 1 to 3 inches, measured at the tops of the

levers. When the free travel of either steering lever becomes less than 1 inch, the steering clutch linkage requires adjustment (refer to "STEERING CLUTCH LINKAGE ADJUSTMENT").

### C. Stopping of Tractor

To stop the tractor, push the throttle operating lever forward and disengage the engine clutch by pushing the clutch operating lever forward, then press on the brake pedals to apply the brakes. If the tractor is parked on a grade where there is a possibility of its rolling, lock the brake pedals in their applied position by the use of the parking brake lock levers. Allow the engine to idle at least 5 minutes so that the engine will cool gradually and uniformly, then pull the engine shut-off knob all the way back to stop the engine.

**IMPORTANT: ALWAYS STOP THE ENGINE WHEN PROLONGED IDLING PERIODS ARE NECESSARY.** This will not only save fuel and unnecessary wear on the engine but will also avoid operating the engine below normal operating temperature. If it is necessary to keep the engine running, it should be run at a speed fast enough to maintain normal engine oil and fuel pressure and with the engine clutch engaged.

While operating the tractor, observe the action of the brakes. The brakes are properly adjusted when the brake pedals each have approximately 1¾ to 2 inches of free travel (refer to "STEERING BRAKES"). The brakes require adjustment before they become loose enough to allow the brake pedals to strike the floor plate when the brakes are fully applied. If the brakes are properly adjusted, and still do not hold, it may be due to oil on the brake linings and the brakes will require washing. Refer to "WASHING STEERING CLUTCHES" for instructions on washing the brakes and steering clutches.



## OPERATING IN MUD OR WATER

The steering clutch compartments are dry compartments. These compartments are provided with drain holes to allow drainage of any oil that might leak into them. The drain holes should be open (plugs removed) during normal operation. When operating in mud, water, or extremely dusty or sandy conditions, the drain plugs (furnished with the tractor) should be installed to prevent the entrance of dirt or water. A steering clutch compartment drain hole (Fig. 52) is located in the bottom of each steering clutch compartment.

The engine clutch compartment is a dry compartment and is provided with two small drain holes, located in the bottom of the engine flywheel hous-

ing. These holes should be open during normal operation. When operating in mud, water, or extremely dusty or sandy conditions, the ¼ inch drain plugs (furnished with the tractor) should be installed to prevent the entrance of dirt or water.

When operating with the drain plugs installed, remove the drain plugs daily to drain any oil that may have accumulated in the compartments, thus preventing it from getting on the clutch discs or the brake linings. If the tractor remains idle at night, it is good practice to remove these drain plugs at the end of the day and reinstall them again before starting the tractor the next day.

## COLD WEATHER OPERATION

When the atmospheric temperature drops to the freezing point or below, the engine crankcase and other oil compartments must be drained and re-filled with oil of lighter viscosity. The air cleaner will also require the use of lighter oil (refer to "SPECIFICATIONS OF LUBRICANTS"). The cooling system must be checked for leaks and filled with an anti-freeze solution to protect it from freezing (refer to "ENGINE COOLING SYSTEM"). All leaking hoses and gaskets must be replaced.

Test and prepare the "COLD WEATHER ENGINE PRIMER" for use as soon as lowering atmospheric temperature indicates that aid in engine starting will be required. Provide a cover for the radiator and for the sides of the engine compartment if the thermostats prove inadequate to maintain the engine coolant operating temperature within the range of 160° to 185° F.

Dependable starting of a "DIESEL" engine by any means can be obtained only with adequate cranking speed. For this reason, it is necessary that the batteries, starter, electrical cables, generator, and the generator regulator be inspected and put in first-class condition at the onset of cold weather (refer to "ELECTRICAL SYSTEM").

If the tractor is to be operated in arctic temperatures, consult your nearest authorized dealer or write the factory for information regarding availability of special cold weather equipment. **CAUTION:** *If mud or snow collects on the tracks during the operating period and is allowed to freeze solid while the tractor is idle, or if the tracks freeze solidly to the ground, apply heat to loosen the frozen material or tracks. Serious damage will be caused by an attempt to break the tractor loose under engine power, or by moving the tractor with large frozen lumps of material in the tracks.*

## ENGINE COOLING SYSTEM

### A. Description of System

The engine cooling system includes the water pump, radiator, engine oil cooler, thermostats, engine temperature gage, cooling fan, and the water passages in the cylinder block and cylinder head. The water pump draws the coolant from the bottom of the radiator and circulates it through the engine oil cooler and through the water passages in the engine. The coolant is discharged from the cylinder head into the water outlet manifold and passes through the thermostat housing and the radiator inlet elbow to the upper part of the radiator. The coolant is cooled as it passes from the top to the bottom of the radiator core by air drawn through the radiator core by the suction-type cooling fan.

The thermostats, located in the thermostat housing at the front of the water outlet manifold of the engine, operate automatically to maintain a normal coolant operating temperature of 160° to 185° F.

### B. General Maintenance

In warm weather, keep the cooling system filled with clean soft water or rain water whenever possible. If soft water is not available and hard water must be used, the hard water should first be treated with a water softener. A commercially reliable rust inhibitor should be added to the cooling system for warm weather operation. A rust inhibitor (soluble oil), available in half pint or quart containers, can be obtained from "Allis-Chalmers" Dealers and should be added to the cooling system in proportions of 1 pint of soluble oil to every 15 quarts of water. **CAUTION: NEVER ADD AN ANTI-FREEZE SOLUTION TO A COOLING SYSTEM THAT CONTAINS A RUST INHIBITOR.** Drain, flush, and refill the cooling system with clean water before adding an anti-freeze solution for cold weather operation.

In winter weather, use an ethylene glycol anti-freeze solution in the system to protect against damage from freezing. This type of anti-freeze has a much higher boiling point than water. After any addition of water or anti-freeze compound, test the solution after the added quantity has become thoroughly mixed to make sure it will withstand the prevailing or anticipated temperature. A mixture of 60% ethylene glycol and 40% water will

provide maximum protection; the use of more than 60% ethylene glycol in the solution will raise the freezing point and provide less protection against freezing.

Keep the radiator air passages free from leaves, trash, and other material which will restrict the flow of air through the radiator.

All leaks in the cooling system must be corrected as soon as they are evident. The fan drive belts and the water pump and generator drive belt must be kept properly adjusted.

The most efficient engine operation is obtained with the coolant operating temperature held within a range of 160° to 185° F. Operating the engine with the coolant temperature below this range will result in incomplete combustion of fuel, higher fuel consumption with less power, and will cause harmful deposits within the engine.

Maintaining the normal coolant operating temperature (160° to 185° F.) depends mostly on proper functioning of the thermostats. If the coolant temperature remains consistently below normal, the thermostats should be removed, checked for proper operation, and replaced if necessary.

### C. Draining of Cooling System

Remove the radiator filler cap and open the cylinder block drain cock, located on the right rear side of the cylinder block. Open the radiator drain cock, using the extension tool (included with the tools furnished with the tractor) inserted through the hole in the lower right corner of the main frame. **CAUTION: When draining the cooling system in freezing weather, make certain that the coolant flows freely from all drain cocks and that the system drains completely.**

### D. Filling of Cooling System

Close the radiator drain cock, located at the lower right corner of the radiator (in the water outlet elbow). Close the cylinder block drain cock, located in the right rear side of the cylinder block. Fill the cooling system through the radiator filler cap opening until the coolant level is within approxi-

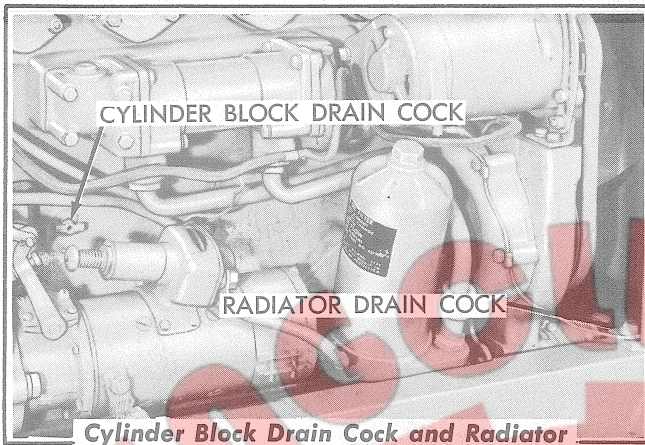

**Cylinder Block Drain Cock and Radiator Drain Cock Location**

FIG. 8

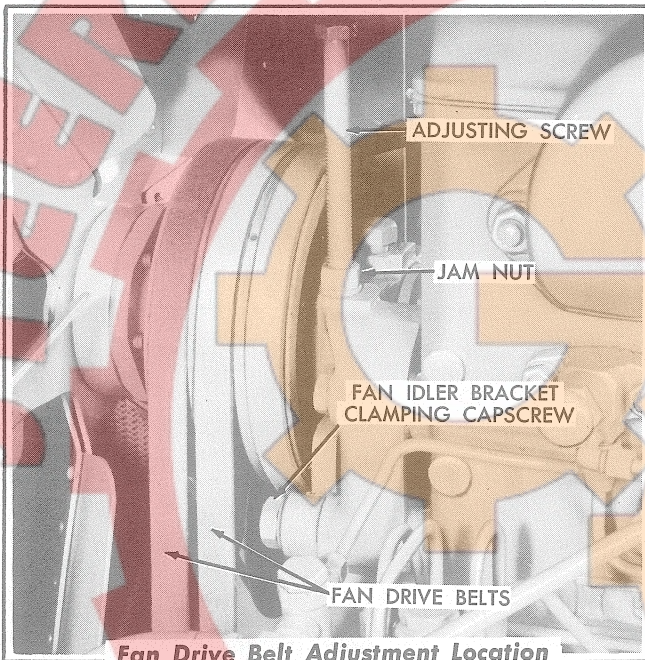

**Fan Drive Belt Adjustment Location**

FIG. 9

mately 2 inches of the top of the radiator and install the radiator filler cap.

### E. Fan Drive Belt Adjustment

The fan drive belts are correctly adjusted when the straight side of the belts can be pressed inward by hand approximately  $\frac{1}{2}$  to  $\frac{3}{4}$  inch at a point half-way between the crankshaft and the fan

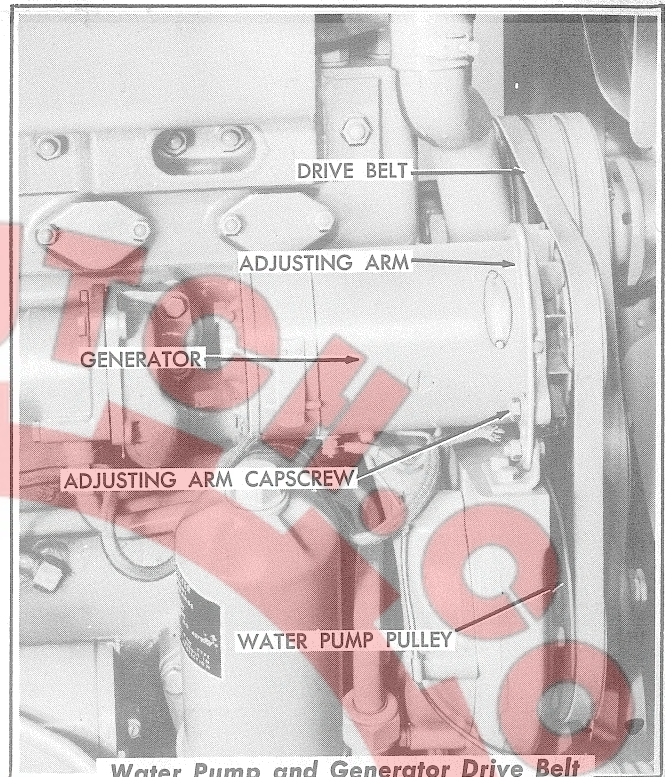

**Water Pump and Generator Drive Belt Adjustment Location**

FIG. 10

pulleys. To adjust the drive belts, loosen the fan idler bracket clamping capscrew. Loosen the jam nut on the adjusting screw and turn the adjusting screw in or out as necessary to obtain the correct tension on the drive belts, then tighten the adjusting screw jam nut. Tighten the fan idler bracket clamping capscrew.

### F. Water Pump and Generator Drive Belt Adjustment

The water pump and generator drive belt is properly adjusted when the belt can be pressed inward by hand approximately  $\frac{1}{2}$  inch at a point half-way between the generator and water pump pulleys. To adjust the drive belt, loosen the generator adjusting arm capscrew, move the generator up or down to obtain the correct tension of the drive belt, then tighten the adjusting arm capscrew.

## FUEL SYSTEM

### A. DESCRIPTION OF SYSTEM

The engine fuel system consists of a fuel tank, first stage fuel filter, fuel transfer pump, second stage fuel filter, fuel injection pump, fuel nozzles, and the fuel lines. There are two fuel pressure systems; the low pressure system and the high pressure system.

The low pressure system consists of the fuel tank, first stage fuel filter, fuel transfer pump, second stage fuel filter, fuel leak-off header, and the fuel return line leading from the fuel sump of the fuel injection pump to the fuel tank.

The high pressure system consists of the fuel injection pump, fuel nozzles, and all high pressure fuel lines connecting the fuel injection pump to the fuel nozzles. The high pressure fuel lines are seamless steel tubing and each line is the same length. These lines being the same length assures the proper timing and the proper amount of fuel to each fuel nozzle. These lines are not interchangeable; when ordering lines for replacement, specify for which cylinder the line is ordered.

The fuel is drawn from the fuel tank, through the first stage fuel filter, by the fuel transfer pump. The fuel is then forced by the transfer pump, through the second stage fuel filter and to the fuel injection pump. The amount of fuel required for combustion is forced under high pressure by the fuel injection pump, through the high pressure fuel

lines to the fuel nozzles, from which the fuel enters the engine combustion chambers in the form of a fine cone-shaped spray.

There is a certain amount of fuel seepage between the lapped surfaces of each fuel nozzle valve and its body, which is necessary for lubrication. This leakage of fuel accumulates around the spindle and in the spring compartment of each fuel nozzle, and is returned through the leak-off header to the fuel return line, extending to the fuel tank. The excess fuel delivered to the fuel injection pump by the fuel transfer pump is returned to the fuel tank through the fuel return line. A pressure of 5 to 15 P.S.I. is maintained within the low pressure fuel system by a fuel pressure relief valve installed in the fuel return outlet of the fuel injection pump.

The heavy-duty fuel injection pump is of the constant-stroke, distributing-plunger, sleeve control type, the plunger being actuated by a cam and tappet arrangement which also carries the gearing for the distribution function. Its purpose is to meter the fuel accurately and deliver it precisely at a definite moment in the engine cycle and under high pressure to the fuel nozzles. The fuel injection pump plunger is 9 M.M. in diameter and the pump is controlled by a mechanical-centrifugal type (type "C") governor.

The function of the fuel nozzles is to direct the metered quantity of fuel, received from the fuel injection pump, into the engine combustion cham-

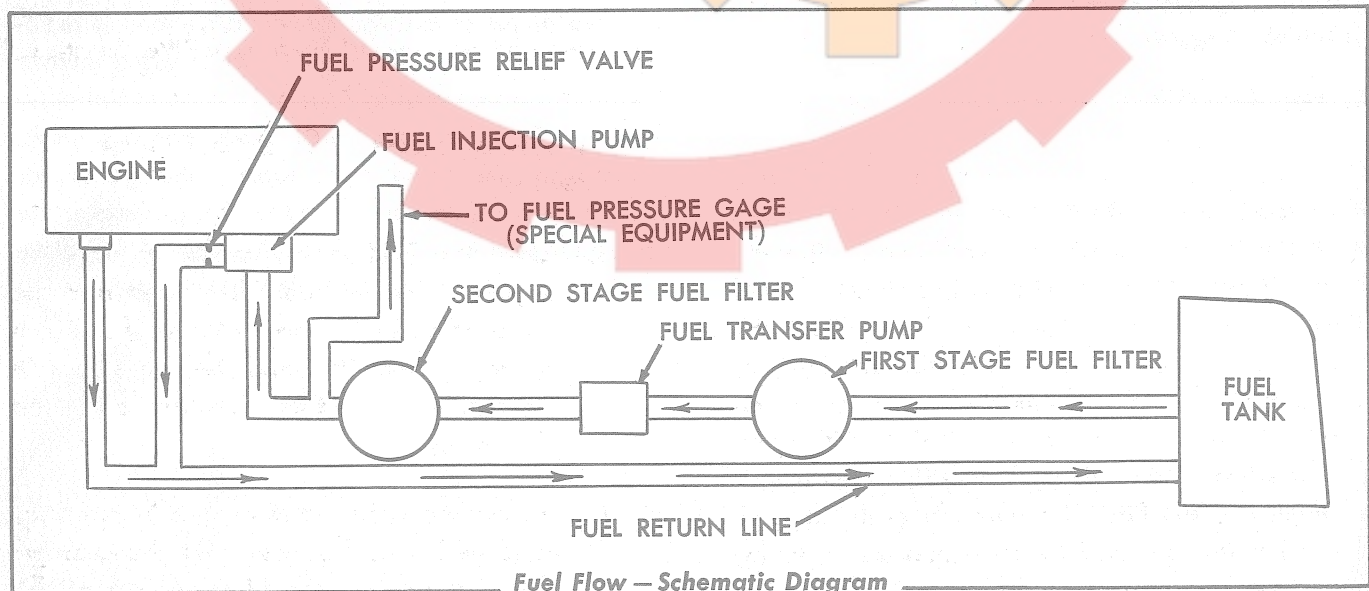

FIG. 11

bers in a definite spray pattern and in such a manner as to produce the most efficient engine performance. The valve of each fuel nozzle is operated hydraulically by the pressure of the fuel delivered by the fuel injection pump.

## B. FUEL TANK AND DRAIN ELBOW

A drain elbow, located at the bottom of the fuel tank, provides a means for draining the tank when flushing and also acts as a sediment sump. Open the drain cock in this elbow before the engine is started at the beginning of the day's operation in warm weather, or shortly after the end of the day's operation in freezing weather, and allow any water and sediment to drain; close the drain cock when clean fuel runs out. Drain and flush the fuel tank when a large accumulation of rust and scale is evident. To drain the fuel tank, remove the plug from the drain elbow.

## C. FIRST STAGE AND SECOND STAGE FUEL FILTERS

### 1. Description

The first stage and the second stage fuel filter each contain a replaceable type element. Dirt and sediment is collected by the first stage fuel filter and prevented from entering the fuel transfer pump. Any dirt or sediment passing through the first stage fuel filter and the fuel transfer pump is collected by the second stage fuel filter and prevented from entering the fuel injection pump. A drain cock is provided in the bottom of each filter shell for draining any water or sediment collected.

### 2. Service

Open the drain cock in the bottom of each fuel filter shell daily, before the start of the day's operation in warm weather or shortly after the end of the day's operation in freezing weather, and allow any water or sediment to drain. Close the drain cocks as soon as clean fuel runs out. Remove and discard the filter element in each filter and install new elements after every 300 to 500 hours of operation (more often if conditions warrant), or when the fuel filters become clogged. Clogged filter elements are usually indicated by irregular engine performance.

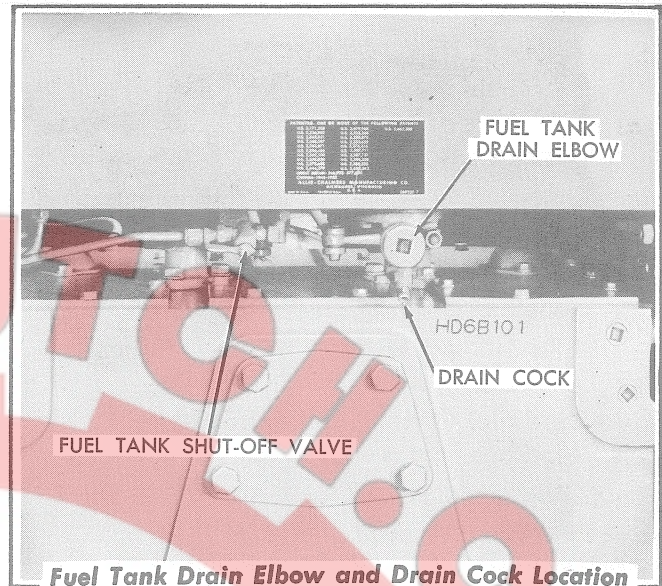

FIG. 12

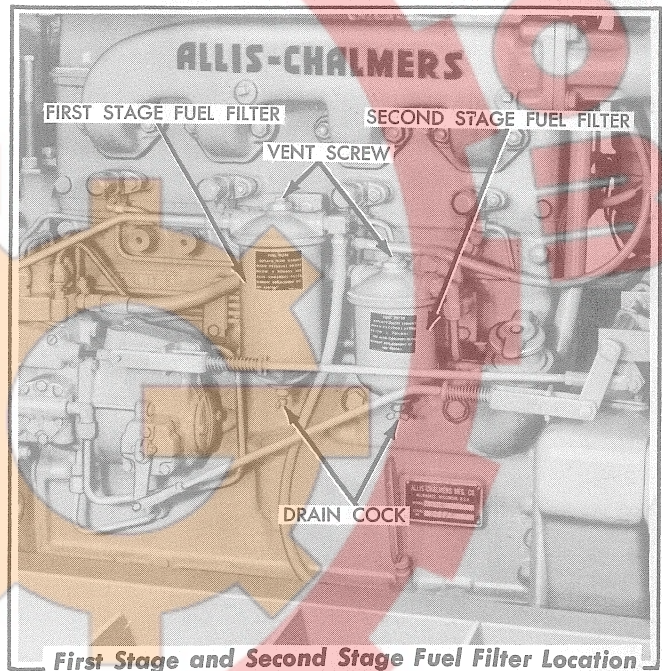

FIG. 13

### 3. To Replace First Stage Fuel Filter Element

- a. Close the fuel tank shut-off valve. Thoroughly clean the fuel filter head and the surrounding area. Loosen the vent screw in the top of the filter and the drain cock in the bottom of the filter shell and allow the filter to drain.
- b. Loosen the shell retaining nut in the filter head until it is free from the shell center-bolt and remove the filter shell from the filter head.

- c. Discard the filter element and the shell gasket. Thoroughly wash and dry the interior of the filter shell.
- d. Install a new filter element (from the element replacement kit) and push it down firmly so that the up-turned edge of the seat plate, attached to the bottom of the shell center-bolt, is firmly impressed into the bottom of the filter element.
- e. Install a new shell gasket (from the element replacement kit) in position in the lip of the shell. Hold the filter shell in position under the filter head and engage the threads of the shell retaining nut with the shell center-bolt and tighten the retaining nut securely.
- f. Close the filter drain cock. Open the fuel tank shut-off valve and allow the filter to fill with fuel by gravity. Tighten the filter vent screw when fuel (free of bubbles) flows from around the vent screw.

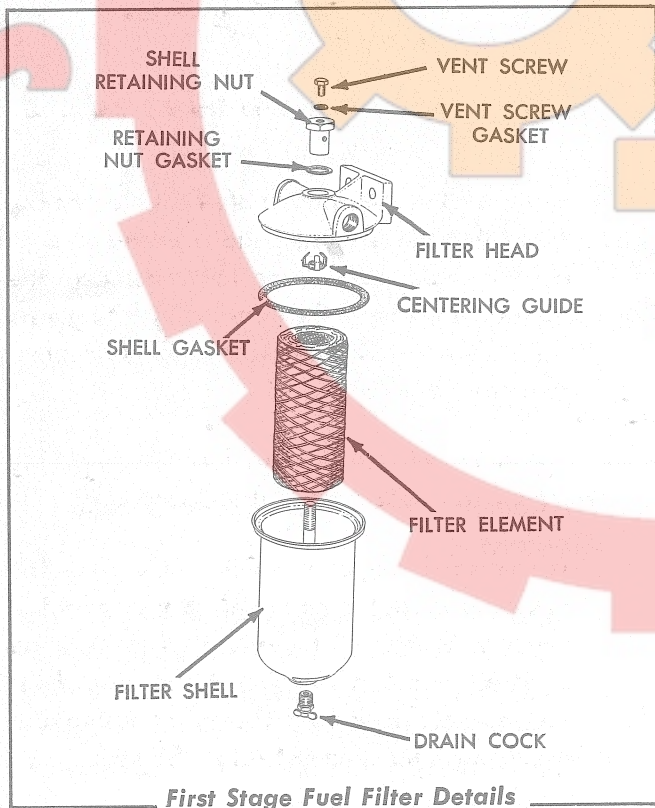

FIG. 14

#### 4. To Replace Second Stage Fuel Filter Element

- a. Thoroughly clean the fuel filter head and

the surrounding area. Loosen the vent screw in the shell retaining nut and the drain cock in the bottom of the filter shell and allow the filter to drain.

- b. Loosen the shell retaining nut in the filter head until it is free from the shell center-bolt and remove the filter shell (with its components) from the filter head.
- c. Remove and discard the filter element. Remove the centering guide, element seating plate, seating plate gasket, metal washer, and element spring from the shell center-bolt. Discard the seating plate gasket, metal washer, and shell gasket.
- d. Thoroughly wash and dry the interior of the filter shell. Close and tighten the drain cock located in the bottom of the filter shell.
- e. Place the element spring (large end downward) in position on the shell center-bolt and install a new metal washer over the shell center-bolt and down onto the element spring.
- f. Install a new seating plate gasket in position in the element seating plate, then install the gasket and element seating plate in position on the shell center-bolt. **NOTE:** When installing the element seating plate and gasket on the shell center-bolt, install the seating plate so that the gasket contacts the metal washer.
- g. Install the centering guide in position on the shell center-bolt and install a new filter element in position in the filter shell. Install a new shell gasket in position in the lip of the filter shell.
- h. Fill the filter shell with CLEAN fuel. Hold the filter shell in position under the filter head, install the shell retaining nut and retaining nut gasket, and tighten the retaining nut securely.
- i. Crank the engine with the starter until a full stream of fuel (free of bubbles) flows from around the loosened vent screw; tighten the vent screw, while continuing to

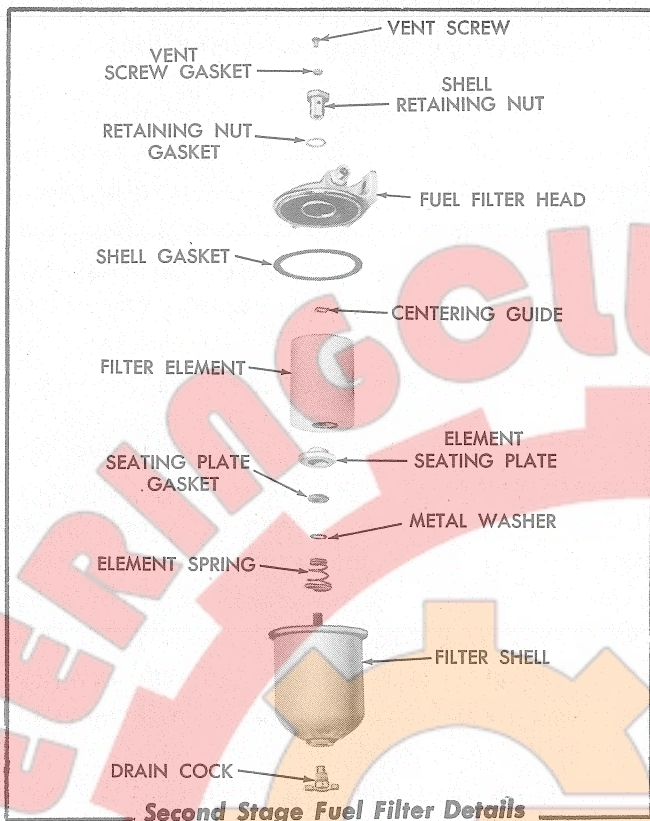

**Second Stage Fuel Filter Details**

FIG. 15

crank the engine.

- j. Start the engine and observe for fuel leaks and correct any leaks found.

#### D. HEAVY-DUTY FUEL FILTER (SPECIAL EQUIPMENT)

On tractors equipped with a Heavy-Duty fuel filter, service as follows: Loosen the drain plug located in the bottom of the fuel filter housing, before the engine is started at the beginning of the day's operation in warm weather or shortly after the end of the day's operation in freezing weather, and allow the water or sediment to drain. Tighten the drain plug when clean fuel runs out. Remove and discard the old filter element and install a new one after every 300 to 500 hours of operation.

#### E. REPLACEMENT OF HEAVY-DUTY FUEL FILTER ELEMENT

1. Close the fuel tank shut-off valve.
2. Remove the drain plug from the bottom of the fuel filter housing and allow the fuel to drain from the filter. Remove the cover clamp ring and lift the cover from the housing.

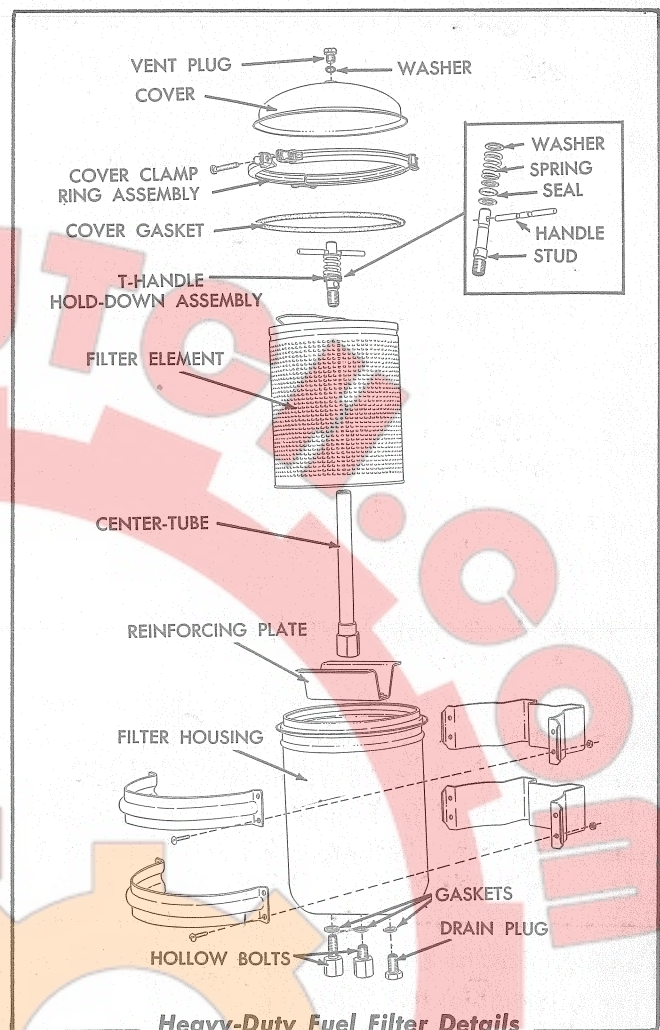

**Heavy-Duty Fuel Filter Details**

FIG. 16

3. Unscrew the T-handle hold-down assembly from the center-tube and remove the T-handle hold-down assembly. Remove the filter element from the housing by lifting with the pull-out bail. Discard the filter element and the cover gasket.
4. Clean the interior of the fuel filter housing thoroughly and install the drain plug.
5. To assure leak-proof sealing, examine the center-tube seal at each end of the new filter element to see that the seals are in good condition and clean. Insert the new filter element into position in the filter housing and press the filter element down firmly.
6. Install the T-handle hold-down assembly and tighten securely.
7. Install a new cover gasket and place the cover in position on the filter housing. Install

the cover clamp ring and tighten securely.

8. Fill the fuel tank so that there will be sufficient fuel in the tank to fill the fuel filter by gravity. Open the fuel tank shut-off valve.
9. Remove the vent plug from the filter cover and allow the filter to fill with fuel by gravity. Install and tighten the vent plug when the fuel flows from the vent plug opening.
10. Observe for fuel leaks at the filter cover, vent plug, and drain plug.

**CAUTION:** Use only a "DIESELPAC" filter element in the Heavy-Duty Filter.

## F. CHECKING FUEL SYSTEM

"Missing" or uneven running of the engine, excessive vibration, stalling when idling, and loss of power are indications of insufficient fuel supply to the engine. Before performing any of the following checks, make certain there is an ample supply of fuel in the fuel tank.

To determine the cause for any of the above conditions, check for the following:

1. Air being drawn into the system.
2. Clogged fuel filter elements and clogged or collapsed fuel line.
3. Inoperative fuel transfer pump.
4. Inoperative fuel pressure relief valve.
5. Inoperative fuel nozzles.
6. Inoperative fuel injection pump.

### a. Check for Admission of Air Into System

Loosen the vent screw located in the top of the second stage fuel filter. Crank the engine with the starter. If fuel containing bubbles flows from around the vent screw, this indicates that air is being drawn into the system. Correct this condition by tightening any loose low pressure fuel line connections, filter connections, and filter shell retaining nuts.

### b. Check for Clogged Fuel Filters and Clogged or Collapsed Fuel Lines

Loosen the vent screw in the top of the second stage fuel filter and crank the engine with the starter. If a full flow of fuel is not obtained from around the vent screw, this indicates a clogged or collapsed fuel line or a clogged first stage fuel filter element. If this condition exists, remove and replace the first stage fuel filter element, or clean or replace the necessary fuel line.

If a full flow of fuel was obtained from around the loosened vent screw in the second stage fuel filter, tighten the vent screw. Loosen the pipe plug in pipe tee (Fig. 27) of the second stage fuel filter, crank the engine with the starter, and check for full flow of fuel from the pipe tee. If a full flow of fuel is not obtained from the pipe tee, this indicates a clogged second stage fuel filter element. Tighten the pipe plug.

### c. Check for Inoperative Fuel Return Pressure Relief Valve or Inoperative Fuel Transfer Pump

The fuel transfer pump should deliver more fuel to the fuel sump of the fuel injection pump than is required for engine operation. The fuel return pressure relief valve (Fig. 20), connected into the fuel return passage of the fuel injection pump, controls the maximum fuel pressure within the fuel sump of the injection pump. When the fuel pressure within the fuel sump of the injection pump exceeds 15 P.S.I., the fuel return pressure relief valve opens and allows the excess fuel to return to the fuel tank. The fuel leak-off from the fuel nozzles is also returned to the fuel tank through this valve. Check for an inoperative fuel return pressure relief valve or an inoperative fuel transfer pump as follows:

- (1) Remove the pipe plug in the pipe tee (Fig. 27) of the second stage fuel filter. Install a suitable pressure gage in the opening from which the pipe plug was removed.
- (2) Start the engine and operate at approximately one-half throttle. Observe the fuel pressure indicated by the gage. The gage should indicate a pressure of 5 to 15 P.S.I. If the gage indicates a pressure below 5 P.S.I. stop the engine and disconnect the fuel re-



turn line from the fuel return pressure relief valve.

- (3) Start the engine and operate at approximately one-half throttle. If the gage indicates a pressure below 5 P.S.I. and a full flow of fuel is observed from the fuel return pressure relief valve, this indicates that the relief valve is stuck in the open position and the valve must be replaced as a unit. However, if the gage indicates a pressure below 5 P.S.I. and little or no fuel is observed from the fuel return pressure relief valve, this indicates an inoperative fuel transfer pump and the pump must be removed and repaired or replaced.
- (4) If a pressure above 15 P.S.I. is indicated by the gage, the fuel return pressure relief valve is inoperative and must be replaced as a unit.
- (5) Stop the engine and remove the pressure gage. Install and tighten the pipe plug. Connect the fuel return line to the fuel return pressure relief valve.

#### **d. Check for Inoperative Fuel Nozzles**

"Missing" or uneven running of the engine and loss of power are an indication of an inoperative fuel nozzle or nozzles. Locate the faulty fuel nozzle or nozzles as follows:

Run the engine at low idle speed and "cut-out" each fuel nozzle in turn by loosening the fuel line connector nut attaching the high pressure fuel line (Fig. 17) to its corresponding fuel nozzle. **NOTE: KEEP HANDS AWAY FROM THE LOOSENED NUTS WHILE PERFORMING THIS TEST.** A decrease in engine speed with the connector nut loosened indicates that the fuel nozzle for that cylinder is functioning properly. If the engine speed does not decrease, the fuel nozzle is inoperative and should be replaced. The "faulty" nozzle should be taken to your nearest "Allis-Chalmers" Construction Machinery Dealer for repair, testing, and adjustment as a special nozzle tester is required.

#### **e. Check for Inoperative Fuel Injection Pump**

If all the possible causes for insufficient fuel supply have been eliminated, and the engine still runs uneven and normal engine performance is not obtained, the fuel injection pump will be considered at fault and should be replaced. The "faulty" fuel injection pump should be taken to your nearest "Allis-Chalmers" Construction Machinery Dealer for repairs and testing. **IMPORTANT: Do not replace the fuel injection pump before making certain that all other possible causes for improper engine operation have been eliminated.**

## G. TEST AND ADJUSTMENT OF FUEL NOZZLES

The fuel nozzles should be removed periodically (approximately every 2000 hours of operation or more often if necessary), tested, and adjusted if necessary.

### 1. Removal of Fuel Nozzle from Engine

- a. Thoroughly clean the fuel nozzle and the surrounding area before removing the nozzle.
- b. Disconnect the fuel leak-off header and the high pressure fuel line from the fuel nozzle. **CAUTION: Do not bend the lines when disconnecting. Cover the ends of the disconnected fuel lines to prevent the entrance of dirt.**
- c. Remove the two nuts and lockwashers securing the fuel nozzle to the cylinder head.
- d. Using a tool similar to the one shown in Fig. 17, pull the fuel nozzle from the cylinder head. Use care when removing and prevent striking the nozzle tip against a hard object, which could result in damage to the nozzle tip.

### 2. Testing and Adjusting Fuel Nozzles

To test and properly adjust the fuel nozzles, a special nozzle tester, similar to the one shown in Fig. 18, is required. Test and adjust each fuel nozzle as follows:

- a. Bolt the nozzle tester to a work bench or clamp it in a vise, as shown in Fig. 18.
- b. Turn the valve of the nozzle tester to the open position. Operate the tester handle until fuel flows from the tester outlet, then close the valve.
- c. Install the fuel nozzle on the nozzle tester as shown in Fig. 18.
- d. Open the valve of the nozzle tester. Operate the tester handle a few quick strokes and observe the "popping" pressure of the fuel nozzle, indicated by the pressure gage

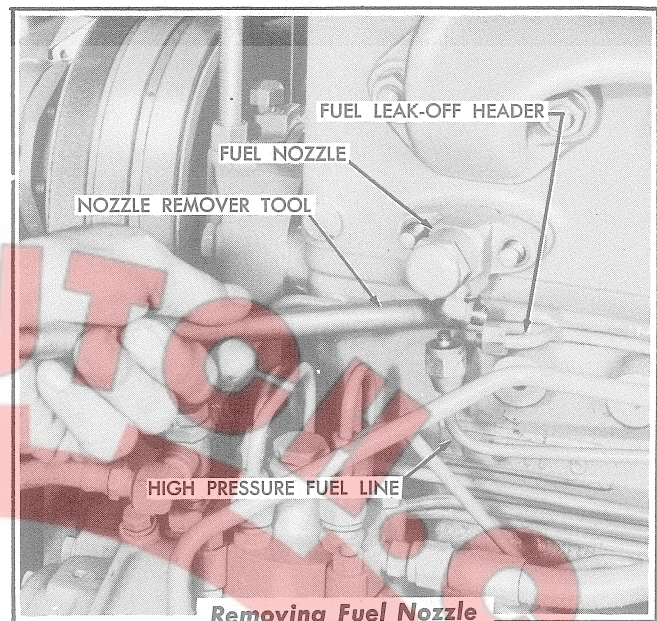
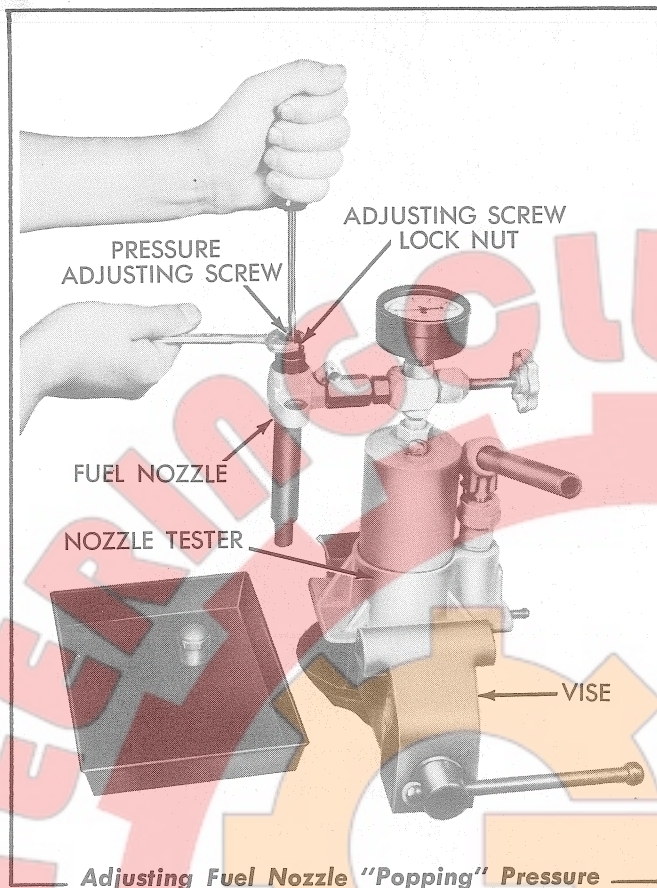

FIG. 17

of the nozzle tester. The "popping" pressure should be 2000 pounds per square inch. If the fuel nozzle is plugged or is leaking, the nozzle must be disassembled, cleaned, inspected, and repaired.

**CAUTION: ALWAYS KEEP THE HANDS AWAY FROM THE NOZZLE TIP WHEN "POPPING" A FUEL NOZZLE AS THE FINELY ATOMIZED FUEL FROM THE NOZZLE TIP IS EJECTED WITH SUCH FORCE THAT IT WILL PENETRATE THE SKIN AND MAY CAUSE BLOOD POISONING.**

- e. If the fuel nozzle is not plugged or does not leak, and the specified "popping" pressure of 2000 P.S.I. is not obtained, adjustment of the nozzle is necessary.
- f. To adjust the "popping" pressure of the fuel nozzle, remove the protection cap from the nozzle and loosen the adjusting screw lock nut. While operating the tester handle, turn the pressure adjusting screw IN to increase or OUT to decrease the pressure as necessary to obtain the correct "popping" pressure. When the correct "popping" pressure is obtained, hold the adjusting screw with a screwdriver and tighten the adjusting screw lock nut. Recheck the "popping" pressure of the fuel nozzle after the adjusting screw lock nut has been tightened. Install and tighten the fuel nozzle protection cap.



Adjusting Fuel Nozzle "Popping" Pressure

FIG. 18

- g. Operate the tester handle and observe the nozzle spray pattern, which should be a fine cone-shaped spray. If the spray pattern is distorted, this is an indication that carbon has collected on the nozzle valve or the nozzle valve is damaged. If this condition exists, remove the fuel nozzle from the nozzle tester, disassemble, clean, and inspect. If the nozzle is damaged, replacement of the nozzle valve and body is necessary.

### 3. Installation of Fuel Nozzle in Engine

- a. Thoroughly clean the fuel nozzle recess in the cylinder head before inserting the fuel

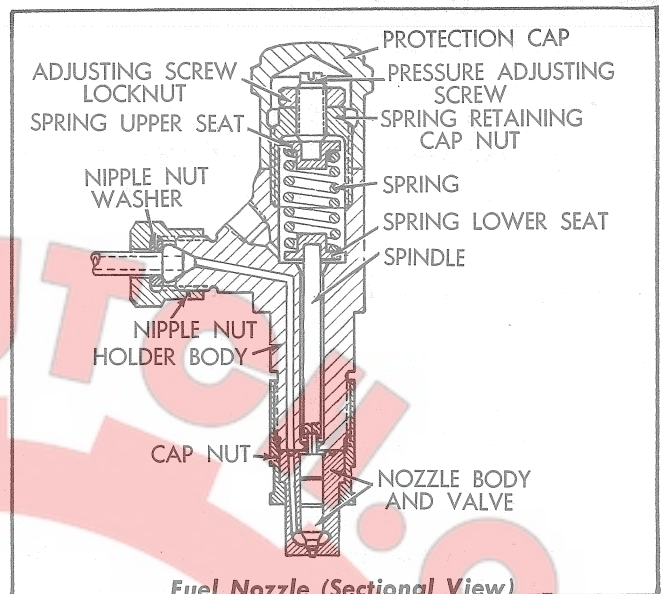

Fuel Nozzle (Sectional View)

FIG. 19

nozzle. Make certain that no small particles of carbon are present which would cause the fuel nozzle to be cocked, thereby, permitting "blow-by" from the cylinder. Hard or sharp tools should not be used for cleaning; a round piece of wood or brass properly shaped is very effective.

- b. **NOTE:** Always use a new fuel nozzle-to-cylinder head gasket when installing a fuel nozzle in position in the cylinder head. Place a new fuel nozzle-to-cylinder head gasket in position on the fuel nozzle and carefully insert the fuel nozzle into position in the cylinder head.
- c. Install two lockwashers and hex nuts to secure the fuel nozzle; tighten the nuts evenly to a torque of 12 to 15 lbs. ft.
- d. Connect the high pressure fuel line and the fuel leak-off header to the fuel nozzle and make certain that the connections are tightened securely.

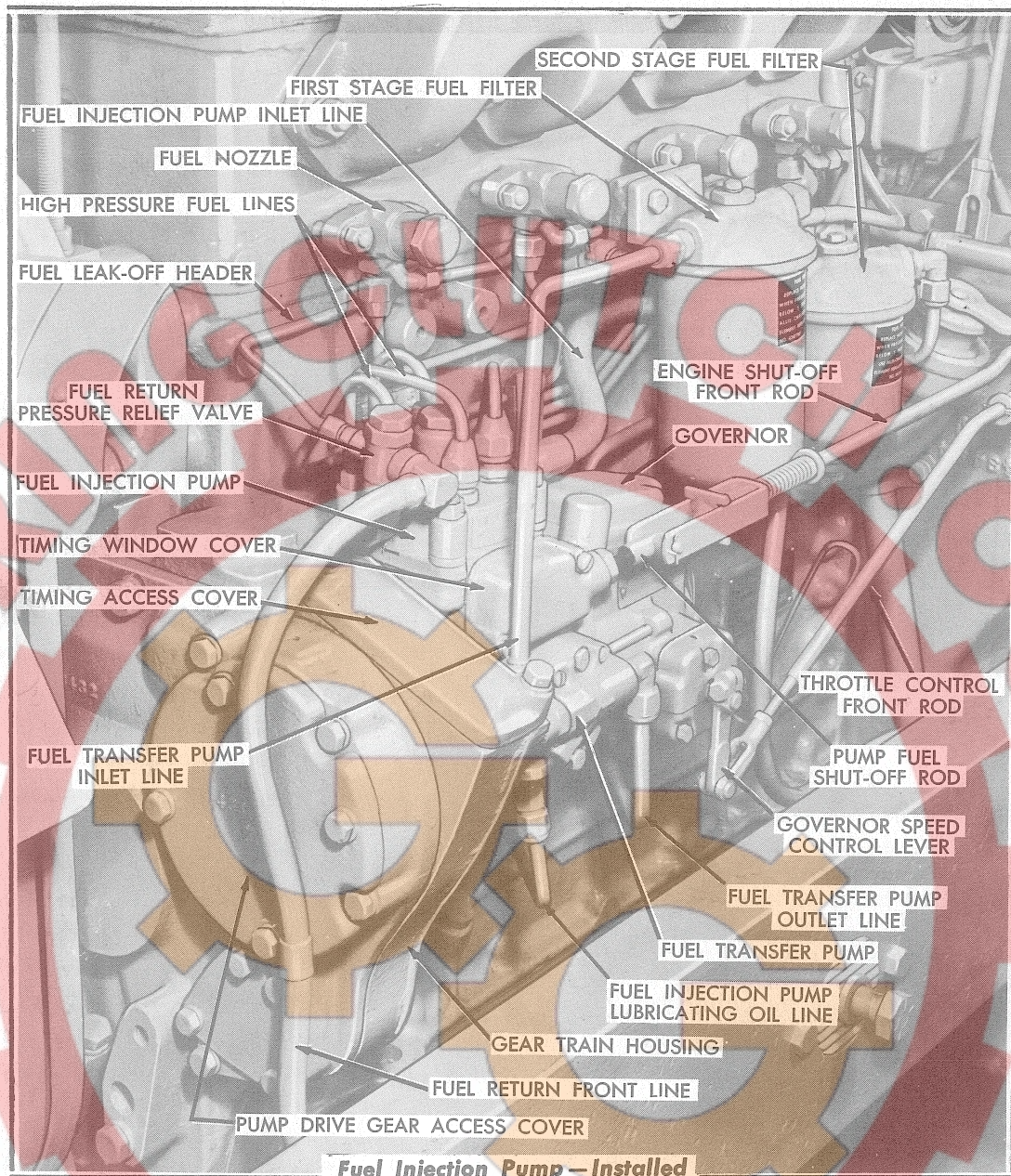

**Fuel Injection Pump—Installed**

FIG. 20

## H. REPLACEMENT AND TIMING OF FUEL INJECTION PUMP

### 1. Removal

Before removing the fuel injection pump from the engine, make certain that the No. 1 piston (piston nearest fan) is near the top on its compression stroke. **CAUTION:** Make certain the engine shut-off knob is pulled back to the "STOP" position.

- a. Remove the rocker arm cover from the engine. Remove the timing hole cover from the upper left side of the engine flywheel housing.

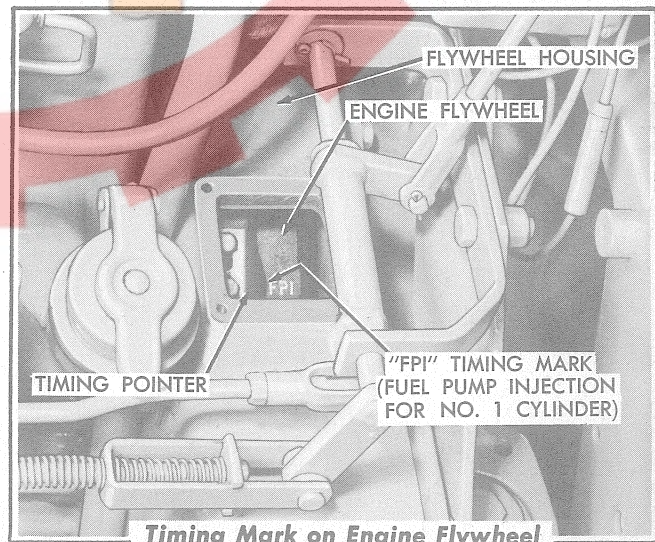

**Timing Mark on Engine Flywheel**

FIG. 21

b. Crank the engine intermittently with the starter until the No. 1 piston is approaching top dead center on its compression stroke. This can be determined by observing the valves for the No. 1 cylinder. With both valves closed (valve push rods at the bottom of their travel), crank the engine by hand until the F.P.I. mark (Fig. 21) stamped in the engine flywheel is aligned with the timing pointer. **NOTE: If the tractor is not equipped with front mounted equipment, the engine may be cranked by hand by using a suitable wrench inserted on the crankshaft pulley retaining capscrew.**

c. If the tractor is equipped with front mounted equipment, the drive shaft universal joint may be used to crank the engine to align the timing mark.

(1) Remove the floor plate, move the gear shift lever to its neutral position, and pull the engine clutch operating lever to its engaged position.

(2) Using a suitable bar, or similar tool, inserted in the drive shaft universal joint, turn the joint counterclockwise (viewed from rear) until the F.P.I. timing mark on the flywheel is aligned with its pointer.

d. Remove the fuel injection pump timing access cover (Fig. 20) and observe the timing pointer of the fuel injection pump. With the F.P.I. timing mark on the engine flywheel aligned with its timing pointer as in b. and c. above, the fuel injection pump timing pointer should be aligned with the center timing mark on the drive gear hub (Fig. 22) of the pump.

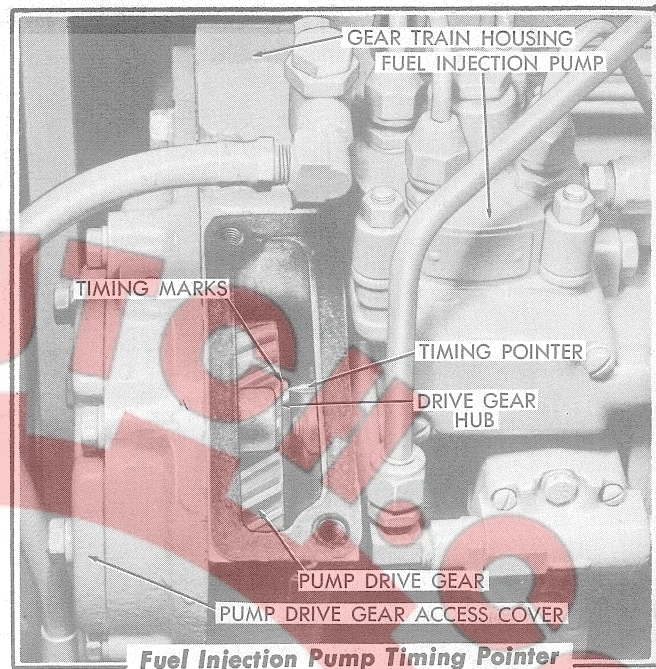

**Fuel Injection Pump Timing Pointer**

FIG. 22

e. Turn the fuel tank shut-off valve to its off position. Disconnect the throttle control front rod from the governor speed control lever. Disconnect and remove the engine shut-off front rod.

f. Refer to Fig. 20 and disconnect and remove the fuel transfer pump inlet line. Disconnect the fuel transfer pump outlet fuel line from the transfer pump. Disconnect and remove the fuel injection pump lubricating oil line.

g. Disconnect and remove the fuel return front line. Disconnect the fuel injection pump inlet line from the fuel injection pump.

h. Disconnect the fuel leak-off header from the fuel return pressure relief valve. Disconnect all the high pressure fuel lines from the top of the fuel injection pump. **IMPORTANT: Tape or cover all the fuel openings to prevent the entrance of dirt.**

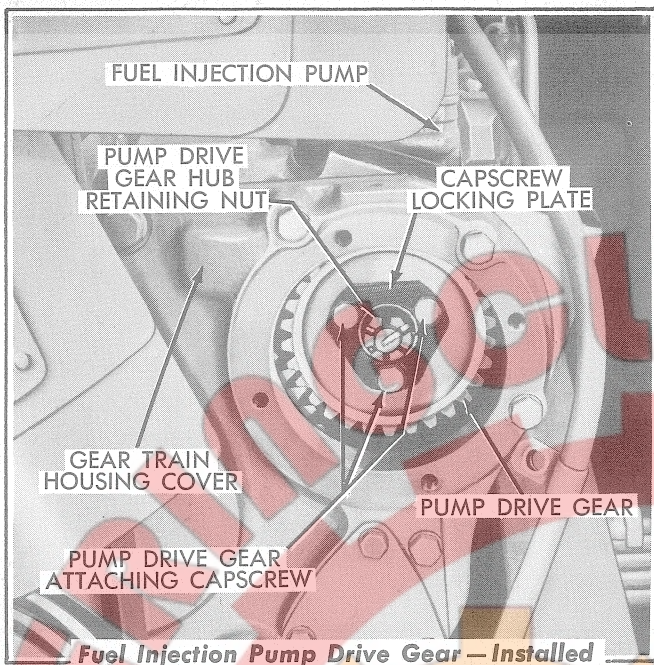

FIG. 23

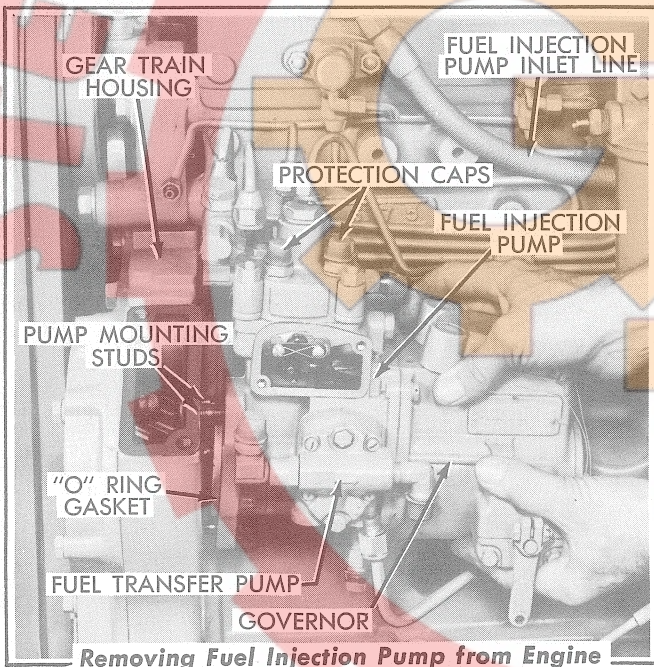

FIG. 24

## 2. Installation and Timing of Fuel Injection Pump

- i. Remove the pump drive gear access cover. Remove the three (3) pump drive gear attaching capscrews and remove the capscrew locking plate (Fig. 23). Remove the pump drive gear.
- j. Remove the three (3) pump mounting stud nuts and lockwashers. Remove the fuel injection pump and governor as a unit as shown in Fig. 24.

- a. Remove the timing window cover (Fig. 20) from the fuel injection pump. One tooth of the plunger drive gear is marked (painted red) for timing the fuel injection pump for injection of fuel to the No. 1 cylinder. Referring to Fig. 25, turn the drive gear hub of the fuel injection pump until the marked tooth of the plunger drive gear is positioned approximately the distance of one (1) tooth to the REAR of the timing pointer in the pump housing, then hold the drive gear hub stationary. While holding the drive gear hub in the above position, the center timing mark on the drive gear hub should be aligned with the timing pointer as shown in Fig. 26. When the drive gear hub is released for the installation of the pump on the engine, the spring pressure on the cam of the pump camshaft will rotate the drive gear hub slightly in the counter-clockwise direction.

- b. With the No. 1 piston near the top on its compression stroke (valve push rods at the bottom of their travel) and with the F.P.I. mark stamped in the engine flywheel aligned with its timing pointer (Fig. 21), the engine is properly positioned for the installation of the fuel injection pump.

- c. Install the "O" ring gasket in position in the pump mounting flange. Install the fuel injection pump in position on the engine and secure the pump to the engine with three (3) pump mounting stud nuts and lockwashers.

- d. Refer to Fig. 23 and install the pump drive gear in position on the pump drive gear hub. Install the capscrew locking plate and start the pump drive gear attaching capscrews but do not tighten at this time. NOTE: The attaching holes in the pump drive gear are elongated so that the pump drive gear hub can be turned slightly to properly time the fuel injection pump.

- e. Insert a wrench in position on the pump drive gear hub retaining nut and turn the

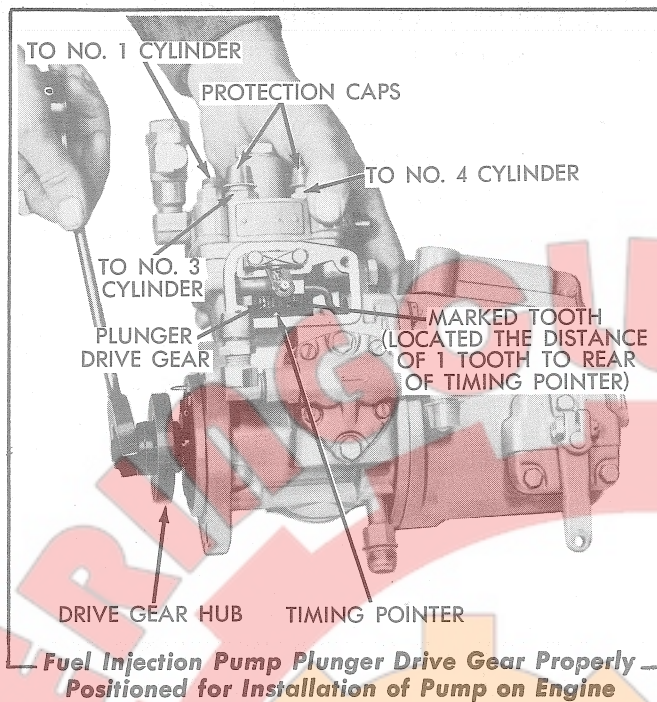

FIG. 25

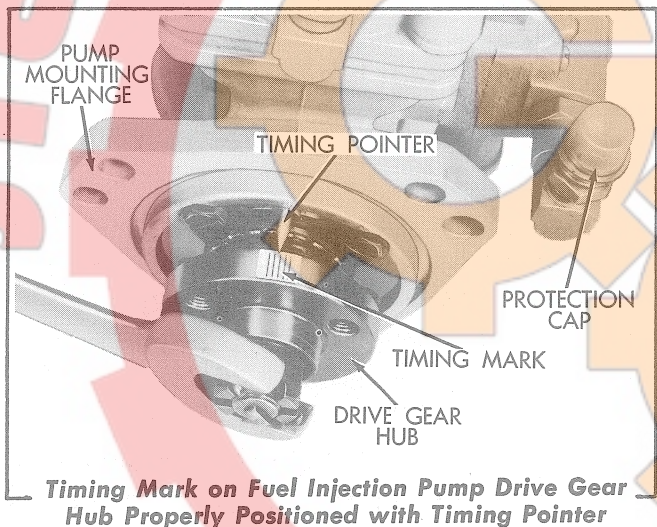

FIG. 26

nut to align the CENTER timing mark on the drive gear hub with its timing pointer. While holding the CENTER timing mark on the drive gear hub in alignment with its timing pointer (Fig. 22), tighten the three (3) pump drive gear attaching capscrews. Remove the wrench used for turning the drive gear hub retaining nut.

- f. Install the pump drive gear access cover and gasket. Install the timing access cover and gasket.
- g. Install the timing window cover and gasket in position on the fuel injection pump.

- h. Connect the high pressure fuel lines (Fig. 45) to their corresponding fittings in the top of the fuel injection pump. Connect the fuel leak-off header to the fuel return pressure relief valve.
- i. Connect the fuel injection pump inlet line to the fuel injection pump.
- j. Install the fuel return front line. Install the fuel transfer pump inlet line and connect the outlet fuel line to the transfer pump. Install the fuel injection pump lubricating oil line.
- k. Connect the throttle control front rod to the governor speed control lever of the governor and install the engine shut-off front rod. Turn the fuel tank shut-off valve to its open position.
- l. Vent the fuel system (refer to "VENTING OF FUEL SYSTEM" paragraph I).

## I. VENTING OF FUEL SYSTEM

### 1. Venting of Fuel Injection Pump and Low Pressure Fuel Lines

Vent the first stage and the second stage fuel filters and the low pressure fuel lines as follows:

- a. Loosen the vent screw, located in the shell retaining nut of the first stage fuel filter, and allow the filter to fill with fuel by gravity. When fuel flows (free of bubbles) from around the loosened vent screw, tighten the screw securely.
- b. Loosen the vent screw located in the shell retaining nut of the second stage fuel filter. Crank the engine with the starter until a full stream of fuel (free of bubbles) flows from around the loosened vent screw, then tighten the vent screw while continuing to crank the engine.

### 2. Venting of High Pressure Fuel System

The high pressure fuel system is usually self-venting, due to the fact that any air trapped by the fuel injection pump is forced out through the fuel nozzles and into the engine combustion chambers. How-

ever, if the fuel lines have been removed, the engine has run out of fuel, or the unit has not been operated for some time, venting of the high pressure system may be necessary to facilitate starting of the engine.

Vent the high pressure fuel system as follows:

- a. Loosen the fuel line connector nut attaching each high pressure fuel line to its corresponding fuel nozzle.

- b. Pull the throttle operating lever back to the high speed position and push the engine shut-off knob to the run position.
- c. Crank the engine with the starter until fuel flows from the ends of all the high pressure fuel lines. Connect the fuel lines to the fuel nozzles and tighten the fuel line connector nuts.

## GOVERNOR

### A. General

The governor was adjusted at the factory to provide for the proper horsepower and a full governed engine speed (under load) of 1800 R.P.M. The governor should not require adjustment during the warranty period. Should an adjustment become apparent while the tractor is in the warranty period, contact your nearest "Allis-Chalmers" authorized Dealer.

### B. Checking Engine Speed

The governor very seldom gets out of working order. If the engine speed is irregular, check the fuel system and all other engine adjustments before changing the governor setting.

Operate the engine until normal operating temperature (160° to 185° F.) is indicated by the engine temperature gage. Hold a tachometer against the front end of the engine crankshaft. With the throttle operating lever all the way forward (low idle position) and with the engine clutch disengaged, the engine speed should be 525 to 550 R.P.M. With the throttle operating lever all the way back (high speed position) the engine speed should be 1930 (+ or - 25) R.P.M.

**NOTE:** *If equipment mounted on the front of the tractor prevents the use of a tachometer at the front end of the engine crankshaft, the engine speed may be checked from the rear of the transmission top shaft. The transmission top shaft turns .535 of engine speed; therefore, top shaft speeds of 280 R.P.M. and 1032 R.P.M. will correspond with engine speeds of 525 R.P.M. and 1930 R.P.M. Remove the bevel gear compartment rear cover*

from the steering clutch and final drive housing and wipe the oil from the rear of the transmission top shaft. Move the transmission gear shift lever to NEUTRAL, start the engine, engage the engine clutch, and check the engine speed by using a tachometer with a suitable extension. Stop the engine and install the bevel gear compartment rear cover and cover gasket.

### C. Low Idle and High Idle Engine Speed Adjustments

Before changing the high and low idle speed setting, move the throttle operating lever to its low and high speed positions and make certain that the throttle control linkage moves the governor speed control lever through its full travel. To adjust the engine speed, proceed as follows:

1. Remove the speed adjusting screw access cover from the governor.
2. Disconnect the throttle control front rod from the governor speed control lever, so that the lever may be moved by hand.
3. With the engine running, loosen the jam nut on the low idle adjusting screw. Hold the governor speed control lever toward the front so that the control lever shaft stop plate contacts the low idle adjusting screw. Turn the low idle adjusting screw *IN* as necessary to increase or *OUT* as necessary to decrease the low idle speed. When the low idle speed of 525 to 550 R.P.M. (280 R.P.M. of transmission top shaft) is obtained, hold the low idle adjusting screw and tighten the jam nut.



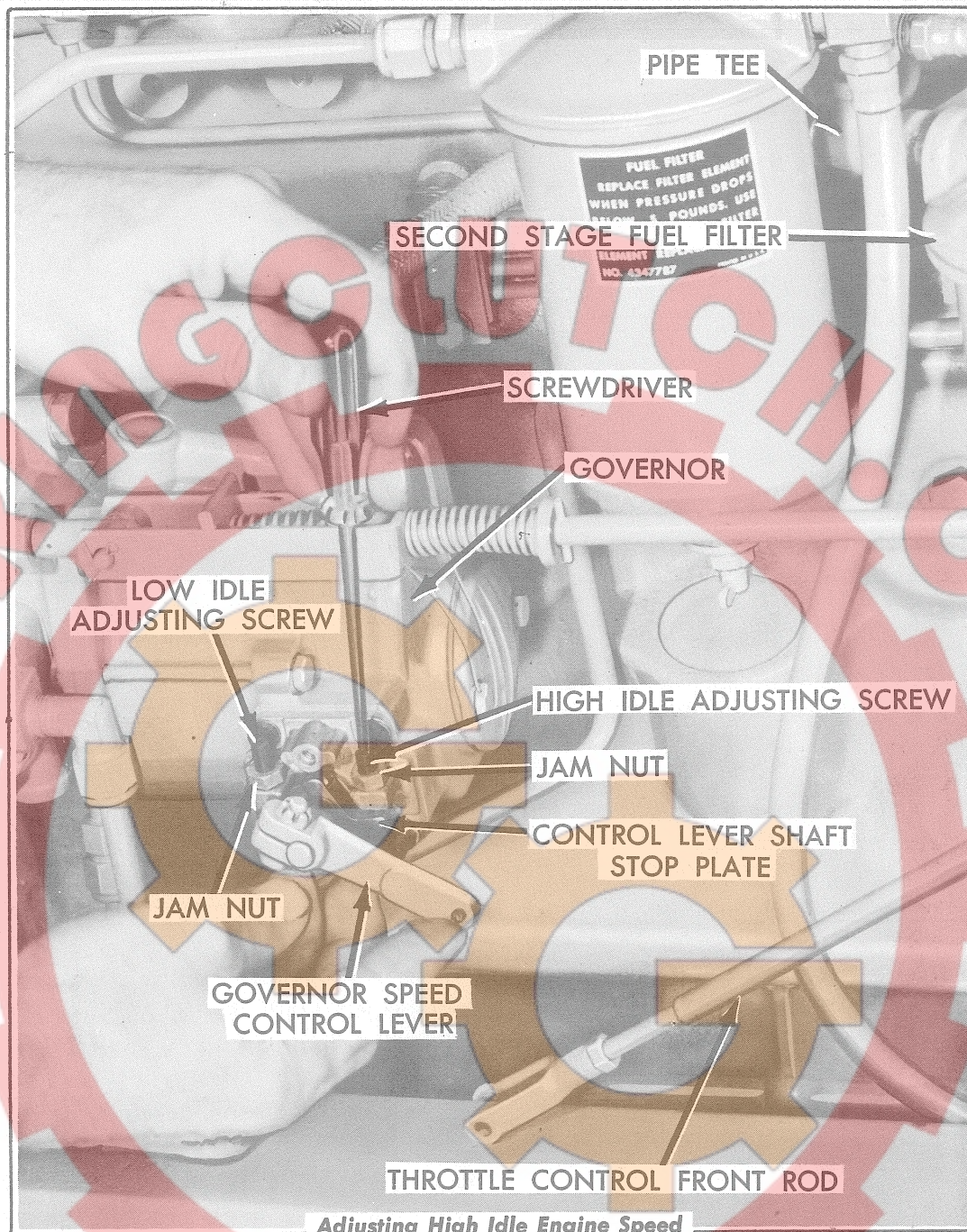

Adjusting High Idle Engine Speed

FIG. 27

4. With the engine running, loosen the jam nut on the high idle adjusting screw. Hold the governor speed control lever toward the rear so that the control lever shaft stop plate contacts the high idle adjusting screw. Turn the high idle adjusting screw *OUT* as necessary to increase or *IN* as necessary to decrease the high idle speed. When the high idle speed of 1930 (+ or - 25) R.P.M.

(1032 R.P.M. of transmission top shaft) is obtained, hold the adjusting screw and tighten the jam nut.

5. Install the speed adjusting screw access cover in position on the governor.
6. Connect the throttle control front rod to the governor speed control lever.

## ENGINE LUBRICATION SYSTEM

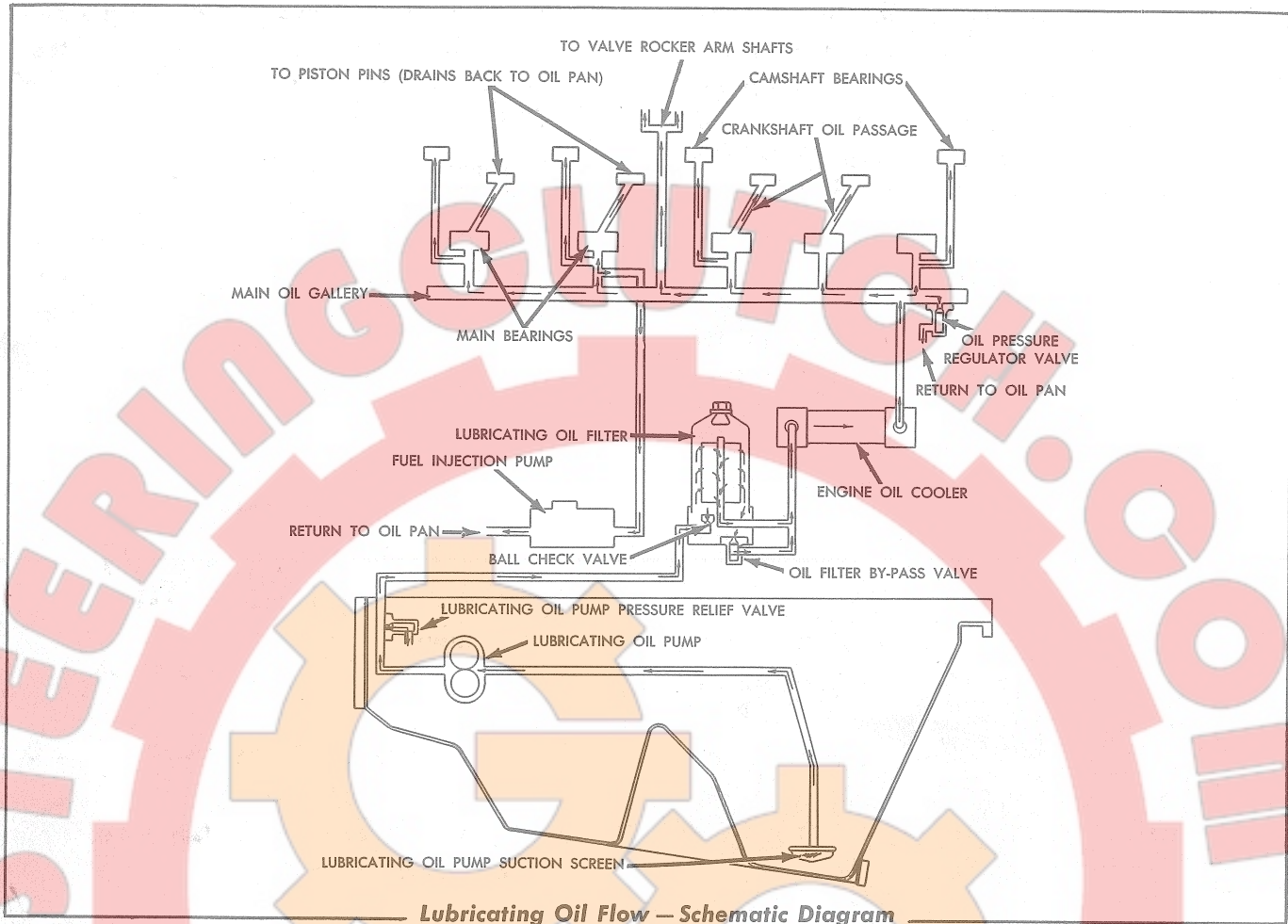

FIG. 28

### A. Description of System

The engine is pressure lubricated throughout by a gear type lubricating oil pump, driven by the oil pump driving gear in mesh with the crankshaft gear.

The lubricating oil pump draws the oil from the crankcase through the oil pump suction screen which is submerged in the lubricating oil. The pump then circulates the oil under pressure through the oil filter, engine oil cooler, and then to the main oil gallery of the engine which extends lengthwise through the cylinder block and parallel to the camshaft. Oil passages direct the oil from the main oil gallery to the camshaft and main bearings and through the rifle drilled connecting rods to the piston pins.

Stabilized oil pressure is maintained within the engine by an oil pressure regulator valve, located in the main oil gallery at the right rear corner of

the cylinder block. Excess oil by-passed through this valve returns to the crankcase oil pan.

A horizontal oil passage through the center of the cylinder block extends from the main oil gallery to a cavity in the left side of the cylinder block. From this cavity there are two openings which extend to the rocker arm assemblies.

An external oil line, extending from the main oil gallery of the cylinder block to the fuel injection pump housing, is provided for lubrication of the fuel injection pump and governor. The lubricating oil delivered to the fuel injection pump is returned to the engine crankcase through an oil return hole in the pump mounting flange.

The oil filter base contains two valves, an oil filter by-pass valve and a ball check valve. Oil delivered under pressure by the lubricating oil pump holds the ball check valve in the open position, allowing the oil to circulate; whenever the engine is

stopped, the ball check valve closes, preventing the oil in the filter from draining back to the crankcase. The oil filter by-pass valve, is provided to by-pass oil directly from the oil pump to the lubrication system in the engine if the oil filter becomes clogged, or if in cold weather the oil is too thick to circulate freely through the oil filter.

### B. Lubricating Oil Filter

The lubricating oil filter, located on the right side of the engine, is of the full-flow type and contains a replaceable type element. A new element must be installed each time the oil in the crankcase is changed, or more often if conditions warrant.

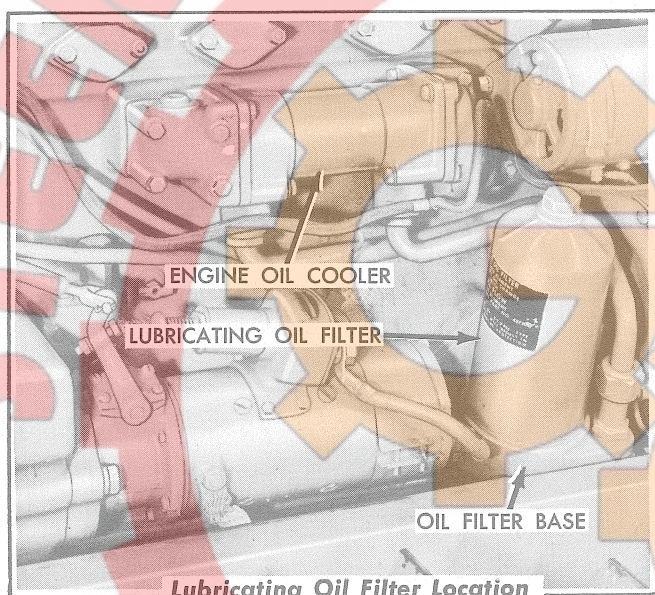
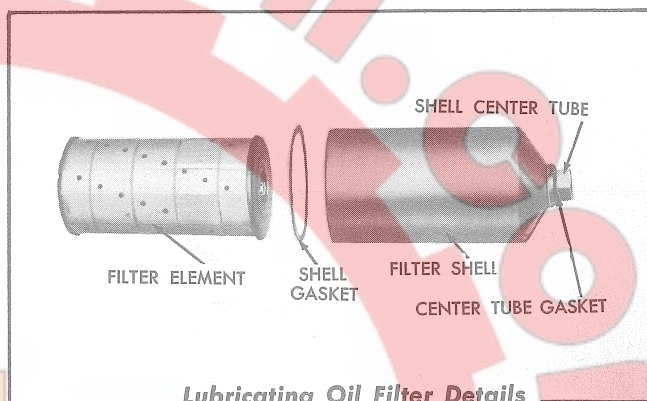

FIG. 29

### C. To Replace Filter Element

1. Thoroughly clean the filter shell and the surrounding area.
2. Loosen the shell center-tube and remove the center-tube, filter shell, and the filter element as a unit from the oil filter base.
3. Remove the filter element from the filter shell and discard the element.
4. Thoroughly wash and dry the interior of the filter shell.
5. Install a new shell gasket in position in the oil filter base. Install a new element in position in the filter shell.

6. Install the filter shell assembly in position on the oil filter base, making certain the shell gasket is properly installed in the base, then tighten the shell center-tube to a torque of 80 to 100 lbs. ft.
7. Start the engine and observe for oil leakage between the filter shell and the oil filter base. Stop the engine, check the oil level of the engine crankcase, and add oil as necessary to raise the oil level to the "FULL" mark on the oil level gage rod.



Lubricating Oil Filter Details

FIG. 30

### D. Heavy-Duty Lubricating Oil Filter (Special Equipment)

On tractors equipped with a Heavy-Duty oil filter, the filter element must be changed at each engine oil change.

### E. To Replace Heavy-Duty Lubricating Oil Filter Element

1. Thoroughly clean the filter cover and the surrounding area. Remove the drain plug from the bottom of the filter housing and allow the oil to drain. Remove the cover clamp ring and lift the cover from the filter housing.
2. Unscrew the T-handle hold-down assembly from the center-tube and remove the T-handle hold-down assembly. Remove the filter element from the housing by lifting with the pull-out bail. Discard the filter element and the cover gasket.
3. Clean the interior of the filter housing thoroughly and install the drain plug.
4. To assure leak-proof sealing, examine the

## ELECTRICAL SYSTEM

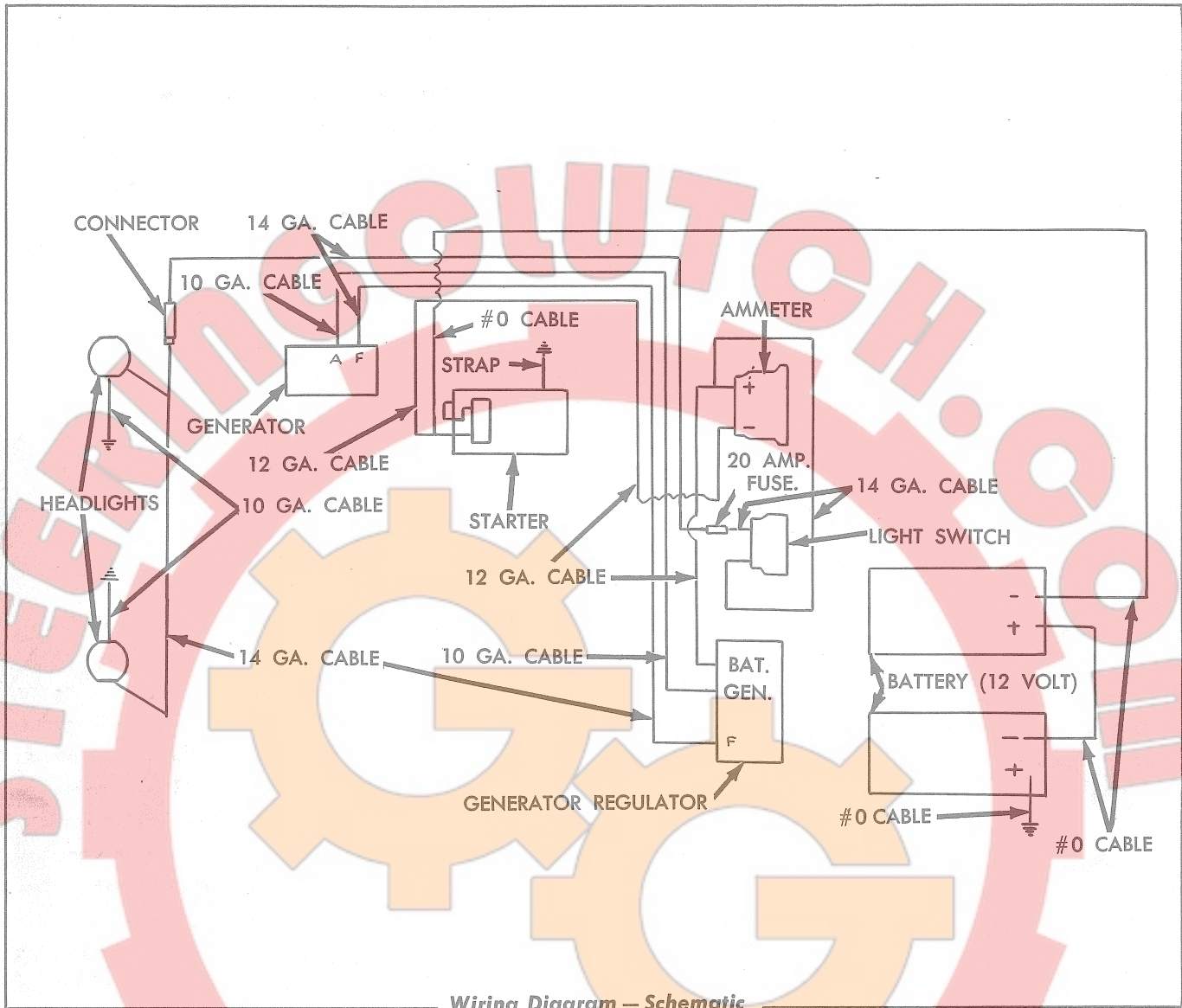

FIG. 32

### A. Description

The electrical system, which includes the starter, generator, generator regulator, ammeter, headlights, and wiring is a 24-volt system throughout. Two 12-volt wet cell storage batteries, located in compartments at the ends of the seats, are used to supply current for the system. Electrical energy drained from the batteries through the operation of the above named units is replaced by the generator. The output of the generator is controlled by the generator regulator to prevent overcharging of the batteries.

### B. Batteries

Check the level of the electrolyte in the batteries

after every 10 hours of operation, or as often as operating conditions prove it necessary. Maintain the level of the solution  $\frac{3}{8}$ " above the plates of the batteries by the addition of clean distilled water. Keep the battery and cable terminals tight and clean. **CAUTION:** To prevent the possibility of bodily injury, always disconnect the battery-to-ground cable from steering clutch housing before cleaning, repairing, disconnecting, or connecting any of the heavy electrical cables. If corrosion occurs, clean the battery posts and terminals with a strong soda solution and coat the terminals lightly with vaseline before connecting them again. The vaseline will prevent further corrosion.

When the atmospheric temperature is below the freezing point, special attention should be given

to hydrometer readings of the batteries. A specific gravity of 1.270 to 1.215 at 80° F. is considered satisfactory for continued use. Specific gravity readings without correction for temperature are practically meaningless. For each 10 degrees that the temperature of the electrolyte is above 80° F., add 4 points to the hydrometer reading and for each 10 degrees below 80° F., subtract 4 points to get the true specific gravity. For example, if the hydrometer reading is 1.250 and the electrolyte temperature is 20° F. (60 degrees below 80° F.), 1.250 minus 24 points equal 1.226 — the true specific gravity.

If the corrected readings are below 1.215, the batteries are not receiving sufficient charge. This might indicate that the generator or the generator regulator requires attention. If these units prove satisfactory, inspect the system for short circuits and for loose or corroded connections. In zero weather there is danger of batteries freezing if the specific gravity is below 1.100. Batteries with a specific gravity of 1.100 will freeze at 18° F.; batteries with a specific gravity of 1.220 will freeze at 31° below zero F. During freezing weather, any addition of water to the cells should be made after the engine is started at the beginning of an operating period to make certain that the water and electrolyte solution will be thoroughly mixed; otherwise it may freeze. The filler caps must be kept tight at all times and the tops of the batteries kept clean and dry.

### C. Generator and Generator Regulator

The generator, mounted on a bracket on the right front side of the engine, is belt driven from the fan pulley. The generator and generator regulator are set to keep the batteries fully charged under normal conditions. The ammeter should indicate a good rate of charge for a short time after starting the engine, or until the generator replaces the energy drained from the batteries during cranking; then it will show little or no charge. It is important that the generator and the generator regulator be maintained in good condition so that the batteries will be kept charged.

Testing and adjustment of the generator and the generator regulator should not be attempted without dependable testing equipment, therefore, it

is recommended that these units be taken to a dependable electrical repair shop when service is required.

### D. Water Pump and Generator Drive Belt Adjustment

The water pump and generator drive belt is properly adjusted when the belt can be pressed inward by hand approximately ½ inch at a point half-way between the generator and water pump pulleys.

#### To Adjust the Drive Belt

Loosen the generator adjusting arm capscrew (Fig. 10), move the generator up or down to obtain the correct tension of the belt, then tighten the adjusting arm capscrew.

### E. Starter

The 24-volt electric starter is mounted on the right side of the engine flywheel housing. A "Dyer" type drive is used to mesh the drive pinion of the starter with the flywheel ring gear for cranking the engine and to automatically disengage the drive pinion when the engine has started. The starter is equipped with a heavy duty switch. The shift lever in the drive housing of the starter is connected by linkage to the starter operating rod. When the starter operating rod is depressed it actuates the switch, closing the circuit between the batteries and the starter, and also shifts the drive pinion of the starter into mesh with the flywheel ring gear. **CAUTION:** When using the starter to crank the engine, and the engine does not start within 30 seconds, allow the starter to cool for 2 minutes before using it again.

Testing and adjustment of the starter should not be attempted without dependable testing equipment, therefore, it is recommended that the starter be taken to a dependable electrical repair shop when service is required.

### F. Electrical Cables

Inspect the electrical cables frequently to detect any loose connections or frayed insulation. Tighten the connections and wrap any frayed spots with friction tape to prevent short circuits. **CAUTION:** To prevent the possibility of bodily injury, always

disconnect the battery-to-ground cable from the steering clutch housing before cleaning, repairing,

disconnecting, or connecting any of the heavy electrical cables.

## AIR PRE-CLEANER AND AIR CLEANER

### A. Description and Purpose

The purpose of the air pre-cleaner and air cleaner is to remove dust and other foreign matter from the air used by the engine. The life of the engine depends largely upon the efficiency of the air pre-cleaner and air cleaner. Fast wear on cylinder liners, pistons, and rings will result if the air cleaner is not kept in good condition and properly serviced.

Air for the engine enters through the air pre-cleaner mounted on top of the air cleaner pipe. The pre-cleaner is designed to impart a rotary motion to the air; this causes the heavy particles of dust to be thrown to the outside of the pre-cleaner shell and deposited therein. A large percentage of the dust in the air drawn through the pre-cleaner is thus removed.

After passing through the air pre-cleaner, the air enters the air cleaner through the pipe that extends down through the center of the air cleaner body. An oil cup filled to a specified level with engine oil is suspended on the lower end of the air cleaner body. As the air is drawn through the air cleaner, a portion of this oil is drawn up onto the screen mats in the main body of the cleaner. Dust still remaining in the air is collected by these oily mats as the air passes through them. The oil, dripping back into the oil cup, carries this dust with it and deposits it in the cup. Thus, only clean air enters the engine air intake for delivery to the cylinders.

A damaged hose, loose hose clamp, damaged gasket, or leak of any kind that allows air to enter the cylinders without first passing through the air cleaner will defeat the purpose of the cleaner; therefore, extreme care should be taken to prevent leaks. Periodic inspection of the above parts and of the air cleaner body for dents, cracks, loosened solder connections, etc., should be made frequently. If any of the above mentioned conditions are found, they must be corrected immediately.

### B. Air Pre-Cleaner Service

Empty the air pre-cleaner whenever the dust level

reaches half-way up on the inspection glass. Remove and clean as follows:

1. Unscrew the wing nut and remove the cap from the shell. Lift the shell from the pre-cleaner body.
2. Empty the dust from the shell and wipe the inside of the shell with a dry cloth. Make sure the fins in the pre-cleaner body are not bent, damaged, or clogged.
3. Wipe the dust off the cap and reassemble the pre-cleaner. Replace the gasket if it is not in good condition. Tighten the wing nut with the fingers; **DO NOT USE A WRENCH.**

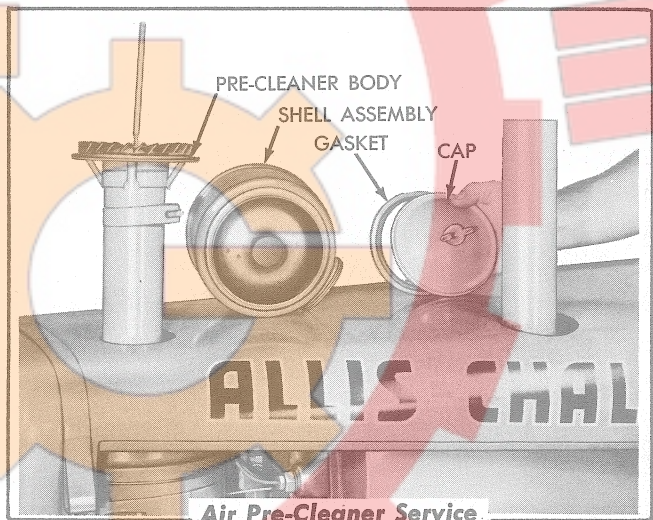

FIG. 33

### C. Air Cleaner Service

The filtering oil in the air cleaner oil cup must be checked daily, or more often when operating under extremely dusty conditions. Keep the oil cup filled with clean engine oil to a level even with the top of the cone in the center of the air baffle. Empty and wash the cup and the air baffle whenever the oil becomes discolored, indicating a quantity of dirt has collected, then refill the cup with clean engine oil. Use same viscosity oil as is used in the engine.

NOTE: SOME "DIESEL" ENGINE LUBRICATING

OILS MAY FOAM WHEN USED IN THE AIR CLEANER. DO NOT USE AN OIL THAT FOAMS AS IT REDUCES AIR CLEANER EFFICIENCY AND IN SOME CASES ALLOWS THE OIL TO BE PULLED OVER INTO THE ENGINE, CAUSING SERIOUS DAMAGE.

Service the air cleaner as follows:

1. Remove the oil cup from the bottom of the air cleaner body. Remove the air baffle retaining ring and the air baffle from the oil cup, then empty the oil from the cup.
2. Thoroughly wash the oil cup and the air baffle with clean solvent or fuel. Remove the air pre-cleaner assembly from the top of the air cleaner and swab out the inside of the air cleaner pipe that extends from the pre-cleaner to the oil cup. Install the air pre-cleaner assembly.

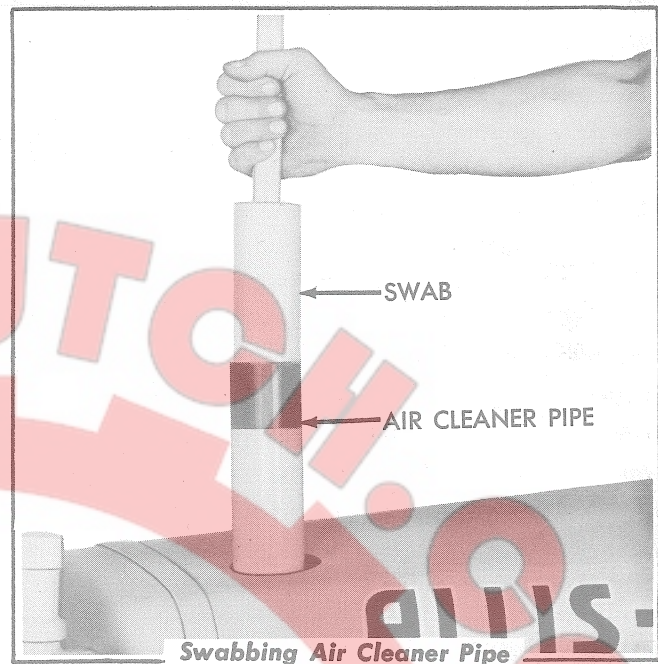

FIG. 35

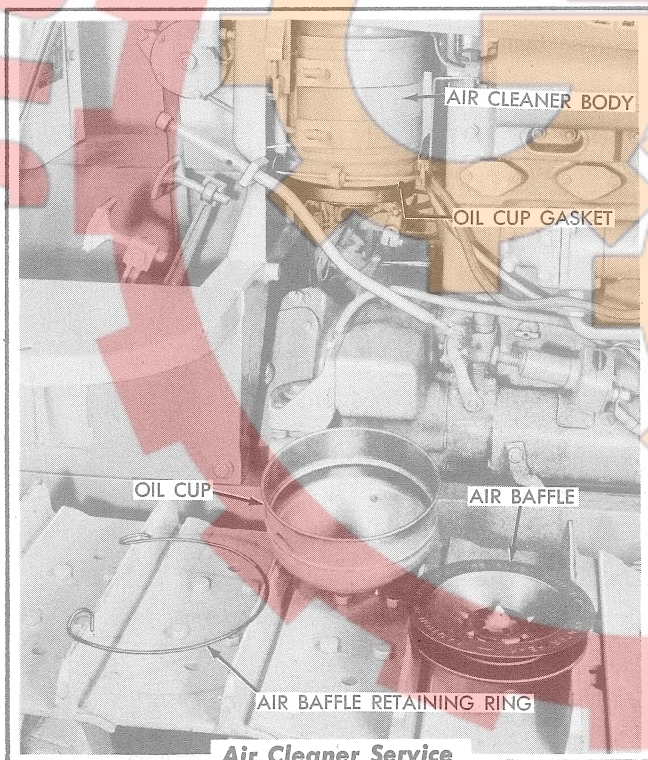

FIG. 34

3. Install the air baffle and retaining ring in the oil cup and fill the cup to the proper level with clean engine oil.
4. Be sure that the oil cup gasket is in good condition, then install the oil cup in position on the bottom of the air cleaner body. Check the hose clamps on the air cleaner elbow hose and make certain that the clamps are tight and that the hose is not crimped, allowing air to enter without passing through the air cleaner.

## COLD WEATHER ENGINE PRIMER

### A. PURPOSE

In warm weather, sufficient heat is generated by compression of the air within the cylinders to ignite the fuel and start the engine within a very short cranking period. However, in cold weather the "drag" caused by cold oil between the pistons and cylinder walls and in the bearings, reduces the cranking speed of the engine. A large part of the heat generated by compression of the air is absorbed by the pistons and cylinder walls. This heat loss and the reduced cranking speed may reduce the temperature of the air in the cylinders to a point too low to ignite the fuel. A starting aid must then be used in starting the engine.

### B. DESCRIPTION

The cold weather engine primer consists of a cold weather starting fluid dispenser assembly, which holds and punctures a capsule containing ethyl ether fluid, a primer pump to force the starting fluid through a small nozzle and into the engine air inlet elbow, a primer elbow assembly, and the necessary lines to complete the system. The dispenser is located on the cowl (to the right of the instruments) and the primer pump is mounted in the cowl with the instruments. The starting fluid is forced through the primer elbow assembly and into the engine air inlet elbow, where it mixes with the intake air and is drawn into the cylinders. Since the starting fluid is highly combustible, it is easily ignited by the heat of the compressed air in the cylinders. The engine will start quickly at low ambient temperatures with the aid of the primer, even at a very slow cranking speed. The starting fluid capsules, available in 7 c.c. and 17 c.c. sizes, can be obtained from "Allis-Chalmers" Dealers. Refer to "STARTING AND STOPPING OF ENGINE" for full instructions on the use of the Cold Weather Engine Primer.

### C. COLD WEATHER ENGINE PRIMER TROUBLE SHOOTING

If the engine is cranked, with the throttle operating lever pulled all the way back and with the engine shut-off knob all the way forward, and does not start after several strokes of the primer, it is advisable to stop cranking and inspect the primer

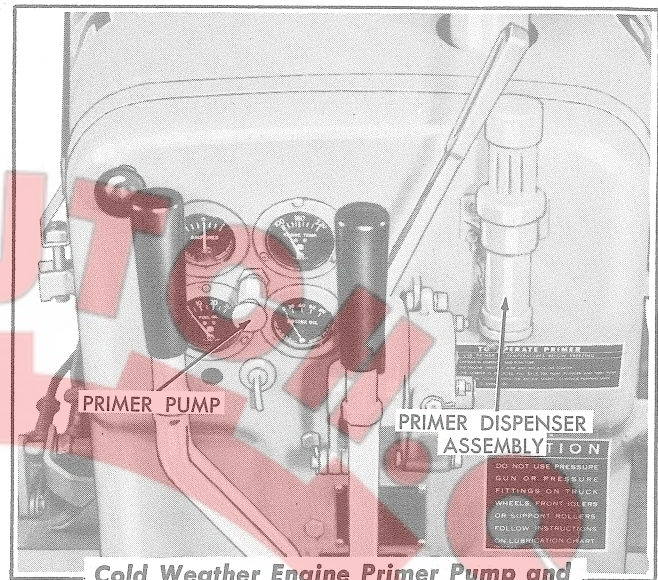

Cold Weather Engine Primer Pump and Dispenser Location

FIG. 36

system for the following possible causes of failure:

#### 1. Primer Elbow Assembly Clogged

This condition will usually be indicated by excessive resistance on the primer pump. A partially clogged primer elbow assembly will prevent the delivery of sufficient starting fluid to the engine air intake system. To clean the primer elbow assembly, remove the elbow assembly from the engine air inlet elbow and remove the small nozzle from the primer elbow assembly. Remove and clean the nozzle swirl pin and open the hole in the end of the nozzle, if clogged. **CAUTION:** Do not enlarge the hole in the end of the nozzle.

After cleaning, reassemble the primer elbow assembly and install the assembly in the engine air inlet elbow.

#### 2. Inoperative Primer Pump

Failure of the starting fluid primer pump to function properly may be due to worn or damaged pump piston rings, a clogged dispenser filter screen, clogged fluid lines, or "frozen" or worn pump check valve balls. The piston rings on the pump piston are made of a special rubber composition and must be replaced by duplicate parts if worn or damaged.

To replace the primer pump piston rings, unscrew



the piston locking nut from the pump barrel and withdraw the piston assembly from the barrel. Remove the piston rings from the grooves in the piston assembly and install new rings. Lubricate the rings and piston with light engine oil and install the piston assembly in the pump barrel.

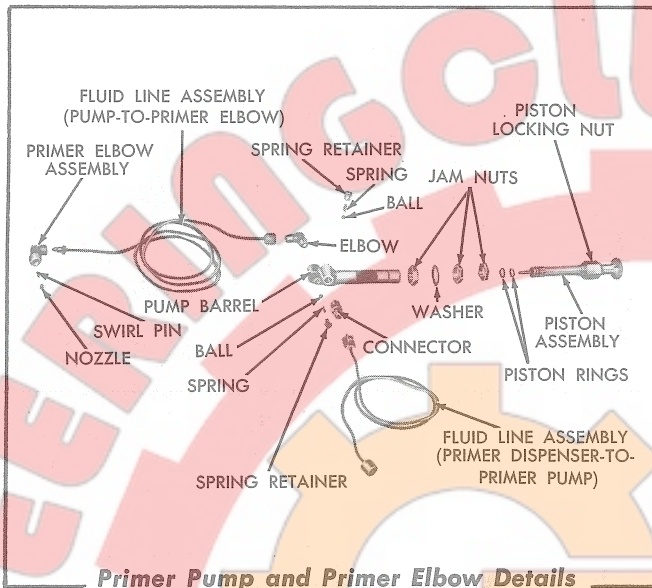
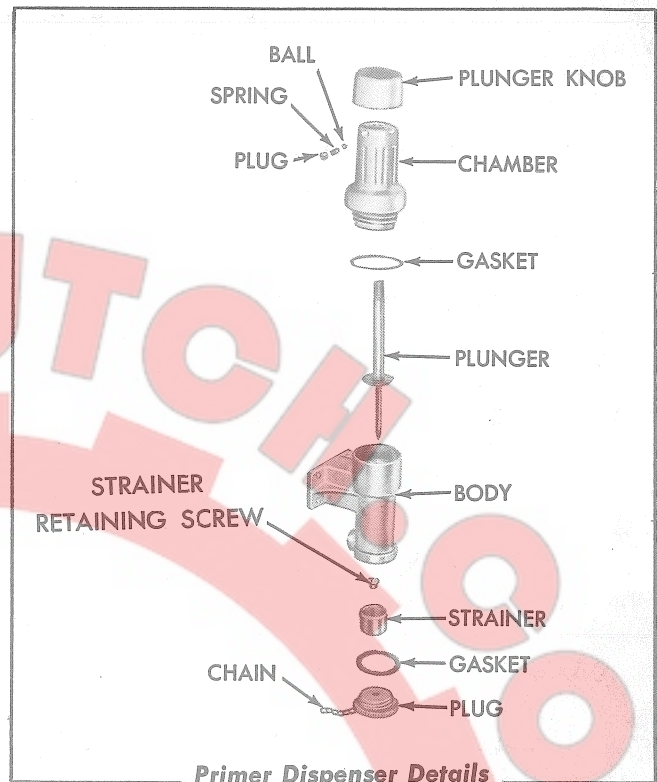

FIG. 37

### 3. Ball Check Valves

The two spring loaded ball check valves, located in the inlet and outlet ports of the primer pump, are provided to close the pump ports at the proper time. When the pump piston is pulled out (suction stroke, drawing starting fluid from dispenser) the ball check valve at the inlet port opens, allowing the fluid to be drawn from the dispenser. When the pump piston is pushed in (delivery stroke, supplying starting fluid to the primer elbow assembly) the ball check valve at the outlet port opens, allowing the pump to force the fluid to the primer elbow assembly.

Worn or "frozen" ball check valves, or broken springs, will prevent the primer pump from operating properly. When this occurs, remove the spring retainers, springs, and balls from the inlet and outlet ports of the pump. Inspect the balls, ball seats, and springs for wear or damage. Clean the



Primer Dispenser Details

FIG. 38

pump barrel and all components thoroughly and reassemble, using new parts where necessary.

### 4. Clogged Dispenser Strainer

A strainer is attached to the plug screwed into the bottom of the dispenser body. If the gelatine starting fluid capsules are not removed soon after puncturing, the gelatine will melt and clog the strainer.

To clean the strainer, unscrew the plug from the dispenser body and wash the strainer and plug in hot water. The strainer may be removed for replacement if necessary, by removing the screw attaching the strainer to the plug.

The dispenser body may be washed without removing it from the cowl by removing the upper chamber, the line connector, and the plug.

Reassemble the dispenser assembly by a direct reversal of the disassembly procedure.

## VALVE ADJUSTMENT AND CYLINDER HEAD

### A. VALVES

#### 1. General

The correct clearance (lash) between the ends of the intake and exhaust valve stems and the rocker arms is very important in a "DIESEL" engine due to the high compression developed within the cylinders. Insufficient valve clearance will cause loss of compression, misfiring, and will eventually cause burning of the valves and valve seats. Excessive valve clearance will result in faulty engine operation, valve tappet noise, and cause rapid wear on the valve operating mechanism.

With the engine at normal operating temperature (160° to 185° F.), the proper valve lash is: intake valves .016" and exhaust valves .020". After any mechanical work has been done which would disturb the valve lash, the intake valves may be set "cold" at .018" and the exhaust valves at .022" clearance so that the engine may be run and allowed to warm up to normal operating temperature. After the engine has been "warmed up" to normal operating temperature, the valve lash should be checked for proper clearance. NOTE: The firing order of the engine is 1 - 3 - 4 - 2.

#### 2. Valve Adjustment

Check the valve clearance periodically and adjust when necessary to obtain the specified lash of .016" for the intake valves and .020" for the exhaust valves as follows:

- a. Operate the engine until it reaches normal operating temperature of 160° to 185° F., then stop the engine.
- b. Remove the air pre-cleaner, engine hood, and the rocker arm cover.
- c. Crank the engine with the starter until both valves for the No. 1 cylinder are closed and the valve push rods are at their lowest position.
- d. Check the clearance between the valve stems and the rocker arms. Use a .016" feeler gage when checking the lash of the intake valve and a .020" feeler gage when

checking the lash of the exhaust valve. The feeler gage should pass between the rocker arm and the corresponding valve stem with a slight drag when the valve lash is properly adjusted. Refer to Fig. 39 for location of the intake and exhaust valves.

- e. Adjust each valve by loosening the lock nut on the adjusting screw and turning the screw clockwise to decrease the clearance

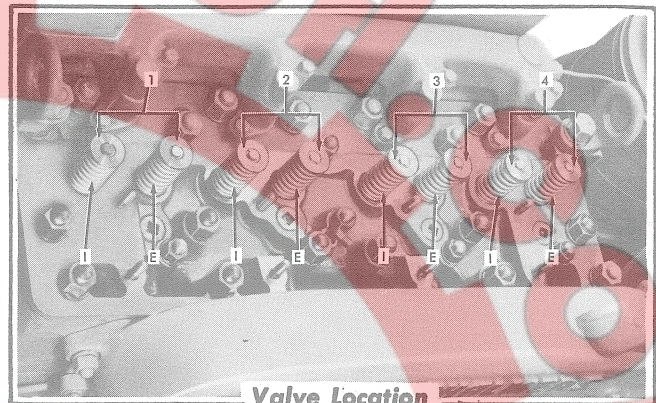

Valve Location

FIG. 39

or counterclockwise to increase the clearance as necessary. When the proper clearance is obtained, tighten the lock nut and recheck to be sure the clearance did not change when the lock nut was tightened.

- f. Repeat the above operations on the valves for the other cylinders. Install the rocker arm cover, engine hood, and the air pre-cleaner.

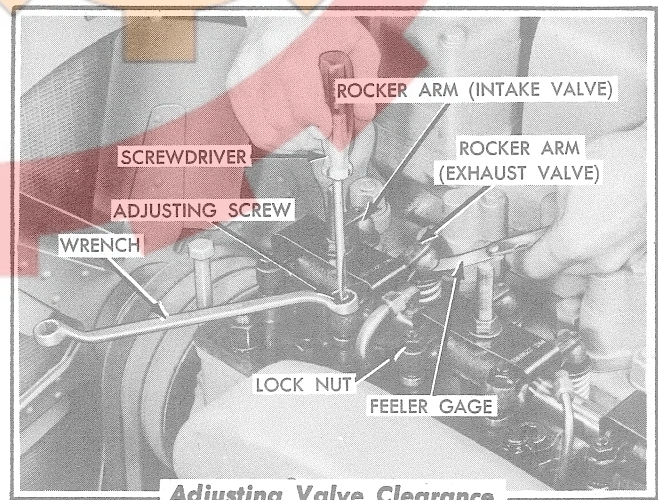

Adjusting Valve Clearance

FIG. 40

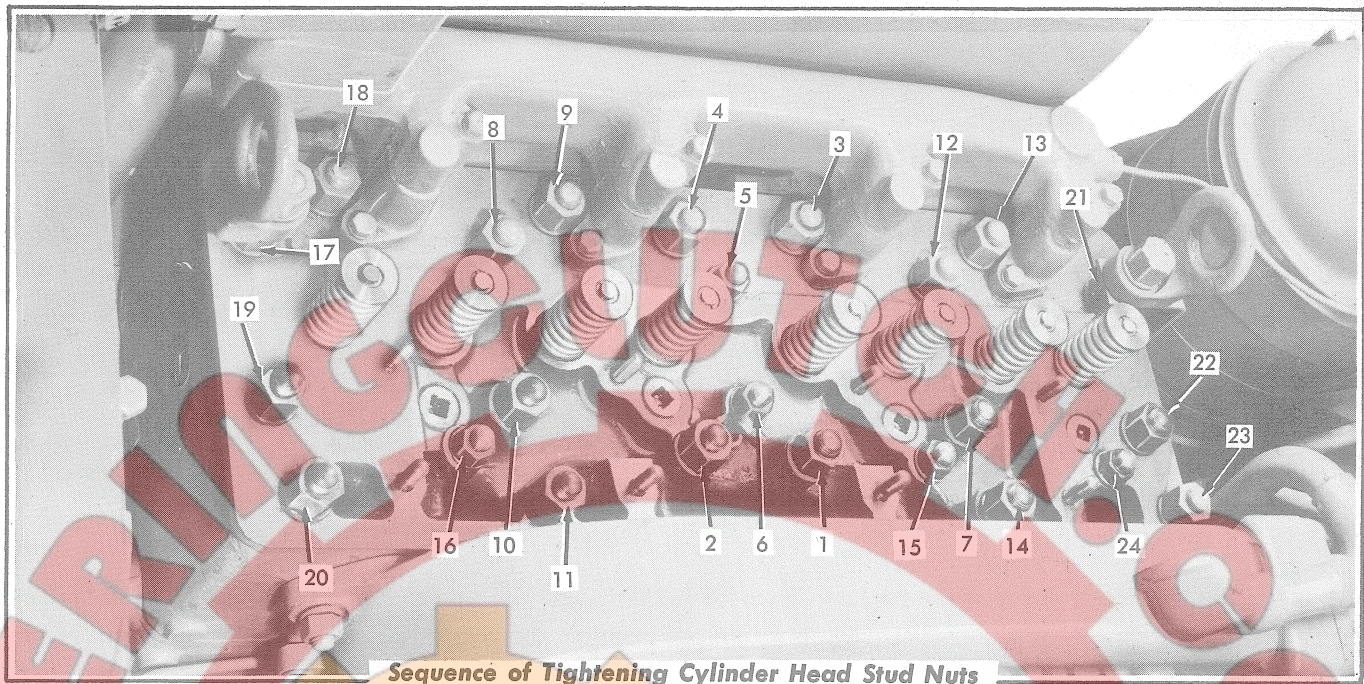

Sequence of Tightening Cylinder Head Stud Nuts

FIG. 41

## B. CYLINDER HEAD

### 1. General

The tightness of the cylinder head stud nuts *MUST* be checked at least two (2) times after a new or rebuilt engine has been placed in operation. The checks *MUST* be made after the first 10 and 100 hours of operation. If the cylinder head stud nuts are not maintained at the correct torque (95 to 105 lbs. ft. torque on the  $\frac{1}{2}$ " and 160 to 180 lbs. ft. torque on the  $\frac{5}{8}$ " cylinder head stud nuts) it is possible that cylinder head gasket trouble will be encountered. After the cylinder head stud nuts have been checked for proper torque, it is also necessary to check the valve tappets for proper clearance.

### 2. Tightening of Cylinder Head Stud Nuts

a. Operate the engine until it reaches normal

operating temperature ( $160^{\circ}$  to  $185^{\circ}$  F.), then stop the engine.

- b. Remove the air pre-cleaner, engine hood, and the rocker arm cover. Remove the rocker arms, shaft, and brackets from the cylinder head as an assembly.
- c. Refer to Fig. 41 for the proper sequence of tightening the cylinder head stud nuts. Using a torque indicating wrench, tighten the stud nuts to the specified torque.
- d. Install the rocker arm assembly in position on the cylinder head. Check and adjust the valve tappets for proper clearance (refer to "VALVES," Paragraph A above).
- e. Install the rocker arm cover, engine hood, and the air pre-cleaner.

### 3. Energy Cells

The energy cells, located in the right side of the cylinder head, constitute part of the combustion chamber. The energy cells are subject to intense heat and may become burnt and coated with carbon. The energy cells should be removed periodically for inspection. Loosen the generator adjusting arm capscrew and lower the generator.

Remove the energy cells as follows:

- a. Remove the two nuts and lockwashers securing each energy cell clamp to the cylinder head.
- b. Using special tools similar to the ones shown in Fig. 42, pull the energy cell plugs from the energy cells.
- c. Using special tools similar to the ones shown in Fig. 43, pull the energy cells from the cylinder head. **NOTE:** The special tools illustrated in Figs. 42 and 43 are available; contact your nearest "Allis-Chalmers" Dealer.

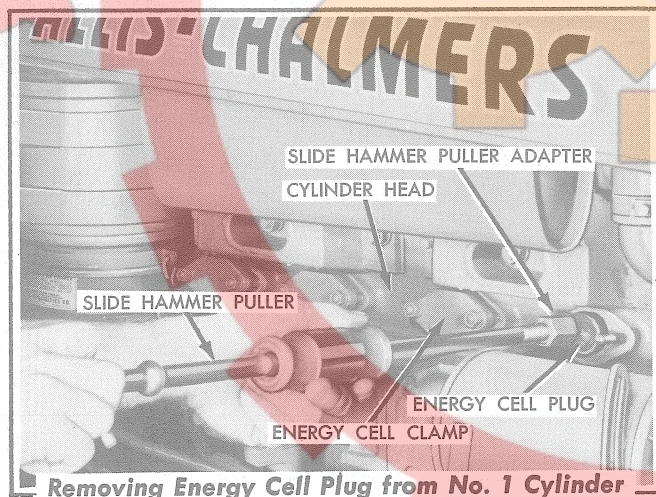

FIG. 42

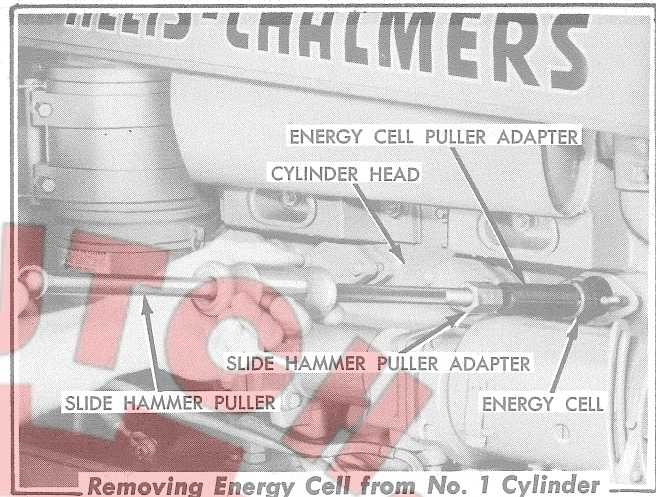

FIG. 43

Note the condition of each energy cell. If a heavy coating of carbon is present on a cell, this is an indication of a faulty fuel nozzle and the corresponding fuel nozzle should be removed and checked. If an energy cell is badly burnt or has burnt spots, the cell must be replaced. Using a piece of hardwood and solvent, or fuel, clean the energy cells. Do not use emery cloth or a metal object to remove carbon. **CAUTION: DO NOT CHANGE THE CONTOUR OF AN ENERGY CELL IN ANY MANNER.**

Make certain that the energy cells and the cell openings in the cylinder head are clean. Using fine grain valve lapping compound, lap the seats of each energy cell with its corresponding seats in the cylinder head. After lapping, remove the energy cell and clean the lapping compound from the cell and the cylinder head. Install each energy cell in position in the cylinder head. Install the energy cell plugs and secure with the energy cell clamps. Adjust the water pump and generator drive belt (refer to "ENGINE COOLING SYSTEM").

## ENGINE CONTROL ADJUSTMENTS

### A. General

The engine shut-off knob is connected by linkage to the pump fuel shut-off rod, located in the rear of the fuel injection pump. When the shut-off knob is pushed all the way forward, the pump fuel shut-off rod is moved forward to the "RUN" position; pulling the knob all the way back pulls the pump fuel shut-off rod to the "STOP" position. Improper adjustment of the engine shut-off knob linkage may result in loss of engine speed or power, failure of engine to start with the shut-off knob pushed in, or failure of the engine to stop when the shut-off knob is pulled back.

The throttle operating lever is connected by linkage to the governor speed control lever, located on the governor. The engine will run at idling speed with the throttle operating lever moved all the way forward; pull back on the lever to increase the engine speed as desired. Improper adjustment of the throttle operating lever linkage may result in loss of engine speed.

### B. Adjustment of Engine Shut-Off Control Linkage

If the engine shut-off controls fail to operate properly, first be sure the linkage and levers are properly lubricated and the condition is not due to binding in the linkage or to a broken spring.

Adjust the shut-off linkage as follows:

1. Push the engine shut-off knob to the "RUN" position. Check the pump fuel shut-off rod (located in the rear of the fuel injection pump) to see if the rod is moved to its extreme forward position (as far as it will go).
2. If the pump fuel shut-off rod is not in the extreme forward position, adjust the engine shut-off front rod as necessary to obtain full travel of the pump fuel shut-off rod.

### C. Adjustment of Throttle Control Linkage

If the throttle controls fail to operate properly, first be sure the linkage is properly lubricated and the condition is not due to binding or to a broken spring. Adjust the throttle control linkage as follows:

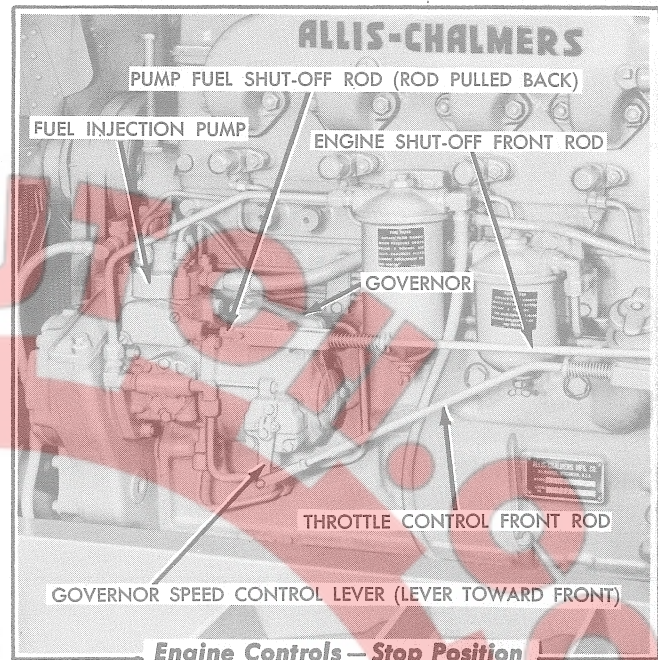

FIG. 44

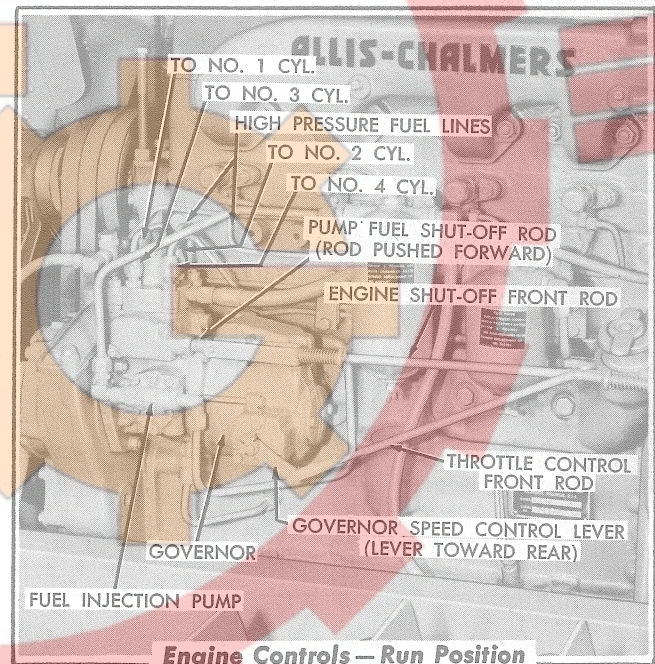

FIG. 45

1. Move the throttle operating lever forward as far as possible (low idle position). Check the governor speed control lever (located on the governor) to determine if the throttle linkage moves the lever forward as far as it will go.
2. Pull the throttle operating lever all the way back (high idle position), and make certain the throttle linkage moves the governor speed control lever (located on the governor)

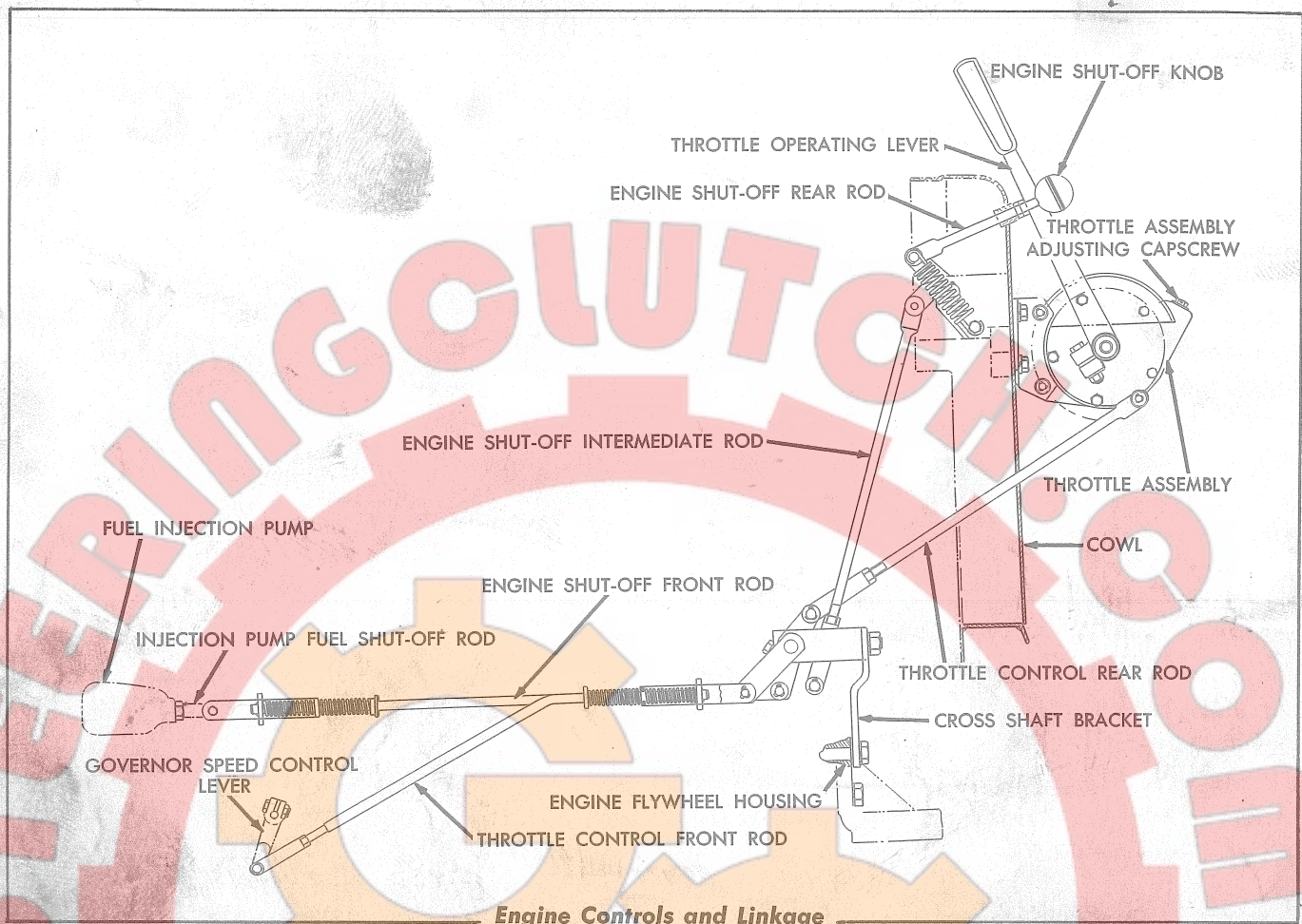

FIG. 46

rearward as far as it will go; shorten or lengthen the throttle control front rod as necessary by turning the control rod yoke.

3. A throttle assembly (mounted on the cowl) containing a friction band, is provided in the throttle control linkage for the purpose of holding the throttle operating lever in any desired speed position between low idle and high speed position. If the throttle operating

lever will not remain stationary when moved to the desired speed position, adjustment of the throttle assembly is necessary. Remove the cotter pin from the throttle assembly adjusting capscrew and turn the capscrew *IN* to increase or *OUT* to decrease the friction band tension as necessary. Install the cotter pin in the throttle assembly adjusting capscrew.

## ENGINE CLUTCH AND CLUTCH BRAKE

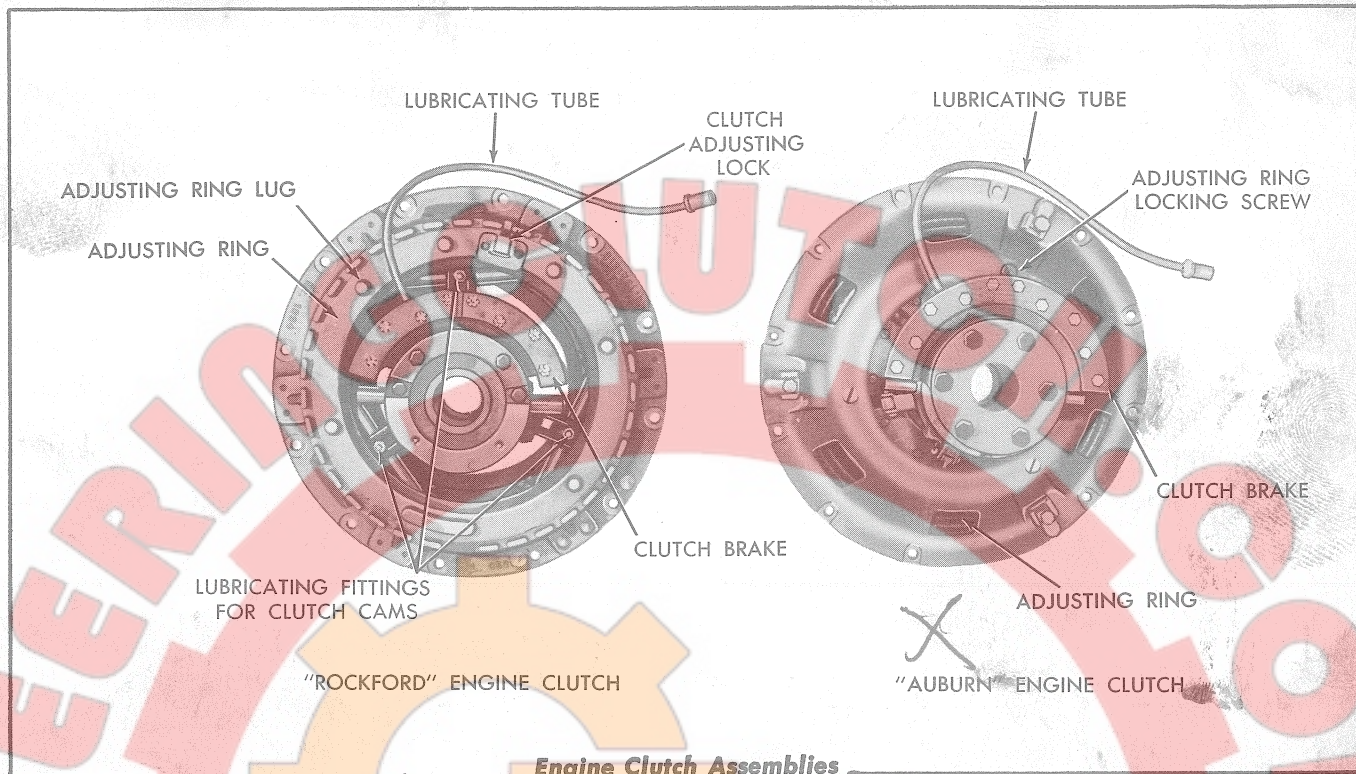

Engine Clutch Assemblies

FIG. 47

### A. DESCRIPTION

The engine clutch is a single plate, dry clutch with an over-center engaging action. A shifting sleeve and bearing mechanism, carried on the clutch shaft and connected by linkage to the clutch actuating levers, is operated by the clutch operating lever to engage and disengage the clutch. An adjusting ring provides a means of maintaining the necessary adjustment to compensate for normal wear on the friction discs of the clutch plate.

A clutch brake assembly, consisting of a stationary lined plate attached to the clutch shifting sleeve bearing carrier and a second plain disc bolted to the clutch shaft, is provided for stopping the rotation of the transmission input shaft when shifting. The clutch brake is applied by pushing forward on the clutch operating lever after disengaging the clutch.

**NOTE:** The tractor may be equipped with an "AUBURN" or a "ROCKFORD" engine clutch.

### B. ENGINE CLUTCH ADJUSTMENT

As the friction discs of the clutch plate wear, the pull required on the clutch operating lever to

engage the clutch lessens. When the pull on the lever diminishes to 15 pounds, an adjustment is necessary. **CAUTION:** Do not operate the tractor when the pull on this lever is less than 15 pounds (engine stopped).

**IMPORTANT:** Since most clutch failures are the result of improper maintenance, it is very important that the clutch be kept properly adjusted at all times and that the clutch components are lubricated as recommended. Do not slip the clutch excessively when engaging.

To check the engine clutch operating lever pull, attach a spring scale to the engine clutch operating lever (attach scale just below the lever hand grip) and weigh the pull required to engage the clutch. When the clutch is properly adjusted, a pull of 25 to 30 pounds (30 pounds maximum) is required on the clutch operating lever for its engagement (engine stopped). The clutch should engage with a distinct over-center snap.

**NOTE:** Before checking the pounds pull required to engage the clutch, make certain that the clutch components are well lubricated and that the clutch linkage is not binding, or a false reading will be obtained.

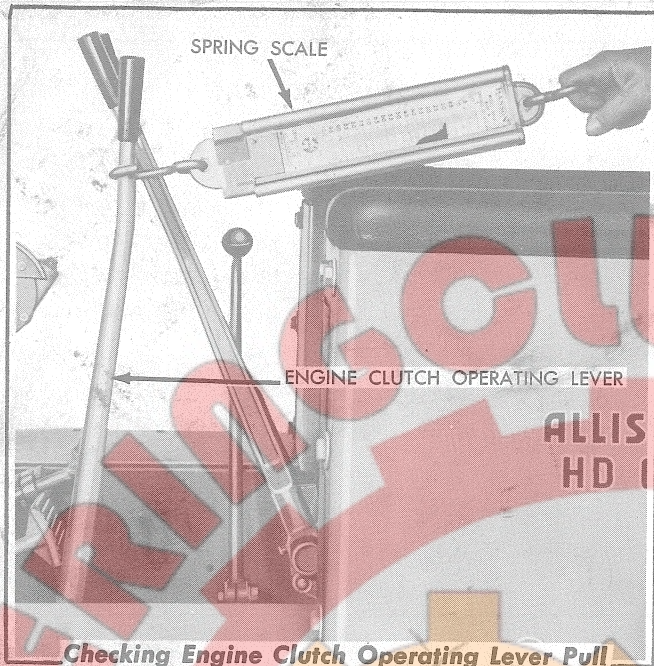

Checking Engine Clutch Operating Lever Pull

FIG. 48

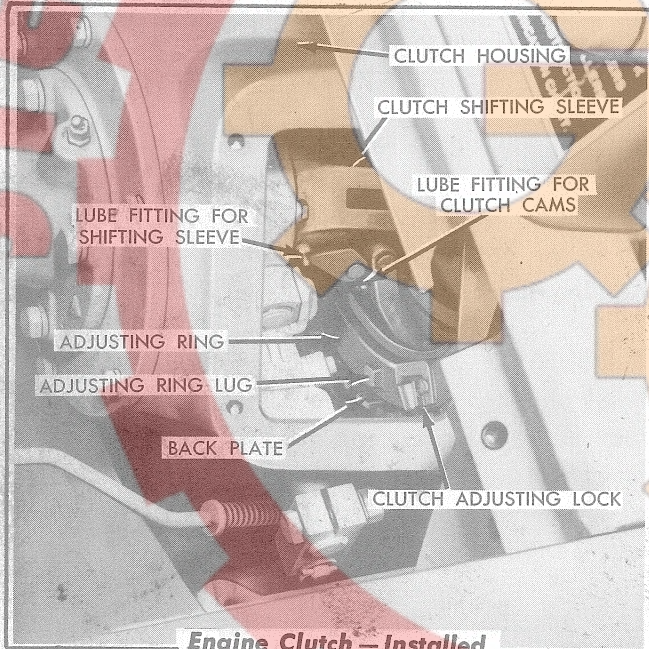

Engine Clutch — Installed  
("Rockford" Clutch)

FIG. 49

### 1. To Adjust the "ROCKFORD" Engine Clutch

- a. Remove the clutch inspection cover from the upper right side of the engine clutch housing.
- b. With the clutch disengaged, crank the engine with the starter until the clutch adjusting lock (Figs. 47 and 49) may be reached through the inspection hole.

- c. Disengage the clutch adjusting lock from the slot in the clutch back plate.
- d. Using a hammer and punch, or a suitable pry bar, drive or pry against one of the adjusting ring lugs and turn the adjusting ring clockwise as necessary to tighten the clutch. Turning the adjusting ring 1 or 2 notches is generally sufficient.
- e. Attach a spring scale to the clutch operating lever (attach scale just below hand grip) and weigh the pull required to engage the clutch. When the clutch is properly adjusted, a pull of 25 to 30 pounds (30 pounds maximum) is required on the clutch operating lever to engage the clutch.
- f. Engage the clutch adjusting lock with the nearest slot in the clutch back plate.
- g. After each adjustment of the engine clutch, inspect the clutch brake disc facing and replace the facing when badly worn.
- h. Clean and install the clutch inspection cover and tighten the capscrews securely.

### 2. To Adjust the "AUBURN" Engine Clutch

- a. Remove the clutch inspection cover from the upper right side of the engine clutch housing.
- b. Disengage the clutch and crank the engine with the starter until the clutch adjusting ring locking screw (Fig. 47) may be reached through the inspection hole. NOTE: The adjusting ring locking screw is the one having a hex head.
- c. Loosen the adjusting ring locking screw just enough so that the clutch adjusting ring can be turned. CAUTION: Do not remove the clutch adjusting ring locking screw. Do not loosen the two slotted head screws.
- d. Tighten the clutch by turning the "notched" clutch adjusting ring clockwise with a screwdriver or a short pry bar until the proper adjustment is obtained. Moving the adjusting ring 1 or 2 notches is generally suffi-



cient. Tighten the clutch adjusting ring locking screw securely.

- e. Attach a spring scale to the clutch operating lever (just below lever hand grip) and weigh the pull required to engage the clutch. When the clutch is properly adjusted, a pull of 25 to 30 pounds (30 pounds maximum) is required on the operating lever to engage the clutch.
- f. Inspect the clutch brake disc facing and replace the facing when badly worn.
- g. Clean and install the clutch inspection cover and tighten the capscrews securely.

#### **D. WASHING ENGINE CLUTCH**

Oil leaks or over-lubrication of the clutch components may cause the clutch facings to become coated with oil or grease. This will cause the clutch to slip even though it is properly adjusted. In this event, the clutch must be washed.

Two drain holes are provided in the bottom of the engine flywheel housing; install two  $\frac{1}{4}$ " drain plugs (furnished with tractor) in the drain holes, and remove the clutch inspection cover. Pour about 1 gallon of cleaning solvent into the clutch housing. Reinstall the clutch inspection cover and operate the engine at low idle speed for approximately 5 minutes with the clutch disengaged. Stop the engine, remove the drain plugs to drain the solvent, and if the solvent is excessively "oily," repeat the washing process.

**IMPORTANT: THOROUGHLY LUBRICATE THE CLUTCH SHIFTING BEARING, SHIFTING SLEEVE, AND IF THE TRACTOR IS EQUIPPED WITH A "ROCKFORD" CLUTCH, LUBRICATE THE CLUTCH CAMS (3 POINTS) AFTER THE CLUTCH HAS BEEN WASHED AS THE LUBRICANT MAY HAVE WASHED OUT OF THESE COMPONENTS DURING THE WASHING PROCESS.**

Operate the tractor with a light load in low gear for a short period until the clutch dries to prevent slippage due to the presence of solvent on the clutch parts.

## STEERING CLUTCHES

### A. Description

Two multiple disc steering clutch assemblies, one located at each end of the bevel gear cross shaft, are provided for steering the tractor. Each steering clutch assembly is enclosed in a brake drum; each drum is bolted to a brake drum hub which is connected to the corresponding final drive pinion. The brake drums serve in conjunction with the steering clutches by stopping the rotation of the final drives when the steering brakes are applied. Each clutch assembly contains 10 friction discs and 10 steel discs, assembled alternately, with springs holding the steel and friction discs tightly together. Pulling back on a steering lever disengages the corresponding steering clutch by forcing a throwout sleeve against a throwout plate in the steering clutch assembly and compresses the steering clutch springs. Compressing the steering clutch springs allows the steel discs and friction discs to separate, therefore, no power is delivered to the corresponding final drive and track drive sprocket.

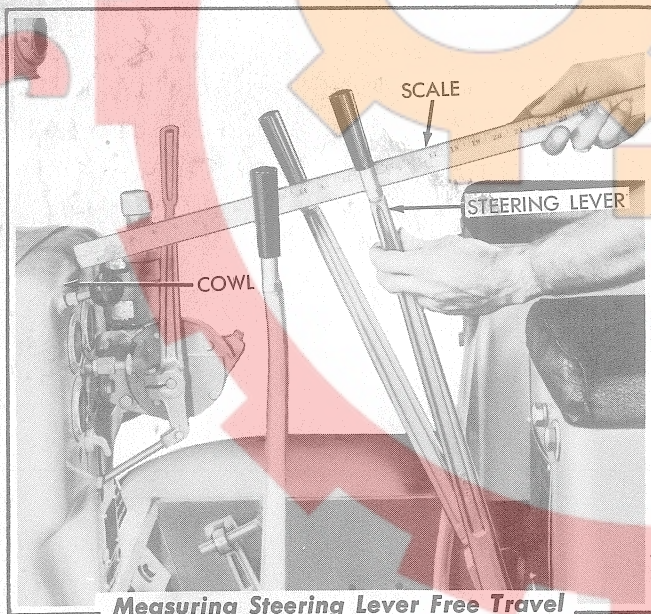

FIG. 50

### B. Steering Clutch Control Linkage Adjustment

The steering clutch control linkage is properly adjusted when the steering levers each have 3" of free travel, measured at the tops of the levers. As the clutch discs wear, this free travel becomes less and an adjustment is required when the free travel has decreased to less than 1". Free travel of the

steering levers is necessary to assure clearance between the clutch throwout sleeve and the clutch throwout plate and to assure full engagement of each clutch.

### C. To Measure the Free Travel of Either Steering Lever

1. Place one end of a ruler or scale against the cowl so that it projects horizontally past the top of the steering lever.
2. With the steering lever forward against its stop, measure the distance from the cowl to the top of the lever.
3. Pull the steering lever back until pressure is felt, which is the point where disengagement of the clutch begins. Note the distance between the cowl and the top of the lever. The difference between the two measurements is the free travel of the lever. If this distance is less than 1" or more than 3", adjustment of the steering clutch control linkage is necessary.

### D. To Adjust the Control Linkage for Each Steering Clutch

1. Remove the seat cushion.
2. Loosen the jam nut of the adjustable yoke at the front end of the steering clutch control rod, extending from the steering lever to the control rod lever of the steering clutch throwout shaft.
3. Remove the yoke pin connecting the adjustable yoke of the steering clutch control rod to the steering lever, then turn the yoke to lengthen or shorten the rod as necessary to obtain 3" free travel at the top of the steering lever. When the correct adjustment is obtained, connect the adjustable yoke to the steering lever, then tighten the jam nut.

### E. Washing Steering Clutches

If the steering clutches slip due to oil on the clutch discs as a result of oil leaking into the steering

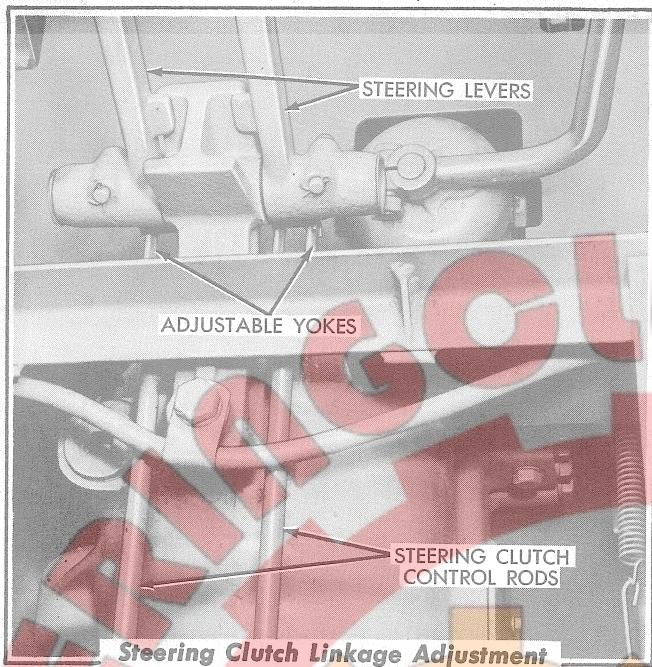

FIG. 51

clutch compartments, wash the clutches with cleaning solvent in the following manner.

1. Install a drain plug in the drain hole in the bottom of each steering clutch compartment.
2. Remove the brake adjusting hole covers from the top of the housing and pour about three gallons of solvent into each clutch compartment; a suitable funnel or trough is needed to do this. Drive the tractor back and forth in a straight line for five minutes, leaving

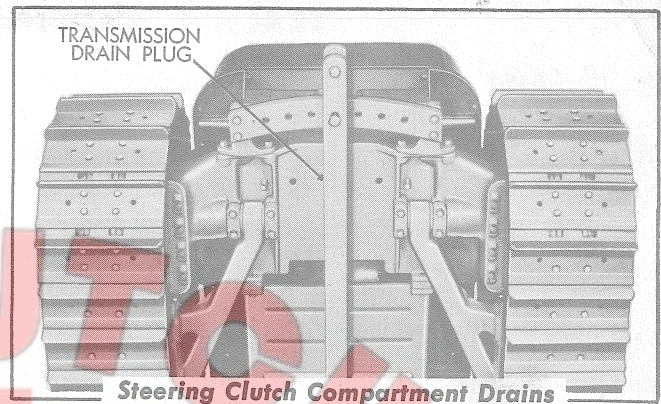

FIG. 52

the steering clutches engaged. The oil on the exterior of the clutches and brakes will be washed off in this operation.

3. Drain the compartments and refill with the same amount of solvent, then drive the tractor back and forth for another five minutes, disengaging one clutch and then the other continually during this period. Disengaging the clutches allows the clutch discs to separate and the solvent will wash the oil from their friction surfaces.
4. Drain the compartments and allow the clutches to dry for a short time. Operate the tractor with a light load in low gear until the clutches become thoroughly dry, otherwise they may slip due to the presence of solvent on the discs.

## STEERING BRAKES

### A. General

The steering brakes are properly adjusted when each brake pedal has  $1\frac{3}{4}$ " to 2" free travel. As the brake linings wear, the free travel of the pedals increases and the pedals will eventually strike the front floor plate before the brakes are fully applied; the brakes will then require adjustment. Brakes adjusted too tight will cause heating, unnecessary brake wear, and loss of power. When the brakes are too loose they will not hold properly and will wear more rapidly due to excessive slipping.

If the brakes are properly adjusted, yet fail to hold, this condition may be due to oil on the brake linings. Remove the steering clutch compartment covers, located over each steering clutch, and observe if oil is present on the brakes. If oil is present on the brakes, this condition can be corrected by washing the brakes in the same manner as washing the steering clutches. Refer to "WASHING STEERING CLUTCHES" and follow steps 1 and 2, then drain the compartments.

Where frequent brake adjustments have been necessary, periodically remove the steering clutch compartment cover, located over each steering clutch, and inspect the brake linings for wear. The brake linings must be replaced before the linings are worn to a point where the lining retaining rivets will contact and score the brake drums.

### B. To Adjust Each of the Steering Brakes

1. Remove the brake adjusting hole cover from

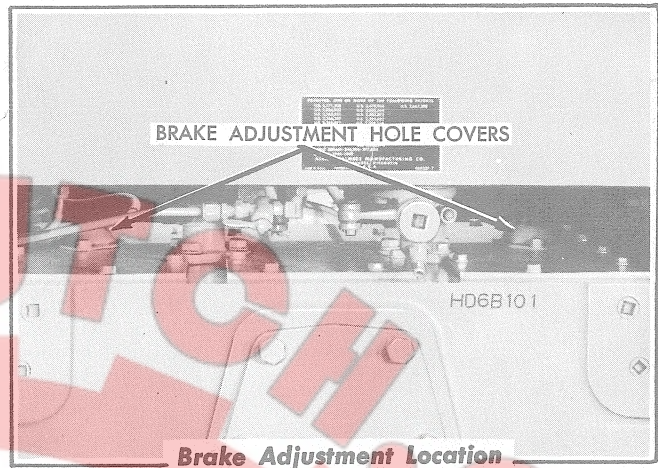

FIG. 53

the steering clutch compartment cover.

2. Turn the brake adjuster (Fig. 54) clockwise until the brake pedal has  $1\frac{3}{4}$ " to 2" free travel. **NOTE:** When adjusting the brakes, it is necessary to turn the brake adjuster in  $\frac{1}{2}$  turn increments so that the lobes on the adjuster will center in the grooves of the spring loaded locking block.
3. With the brake pedal free (pedal all the way back), loosen the jam nut on the brake band supporting screw (Fig. 54). Turn the screw into the housing until the bottom of the brake band is against the brake drum, then back the supporting screw out  $\frac{1}{2}$  turn to allow clearance between the brake band and the drum. Tighten the jam nut on the supporting screw.

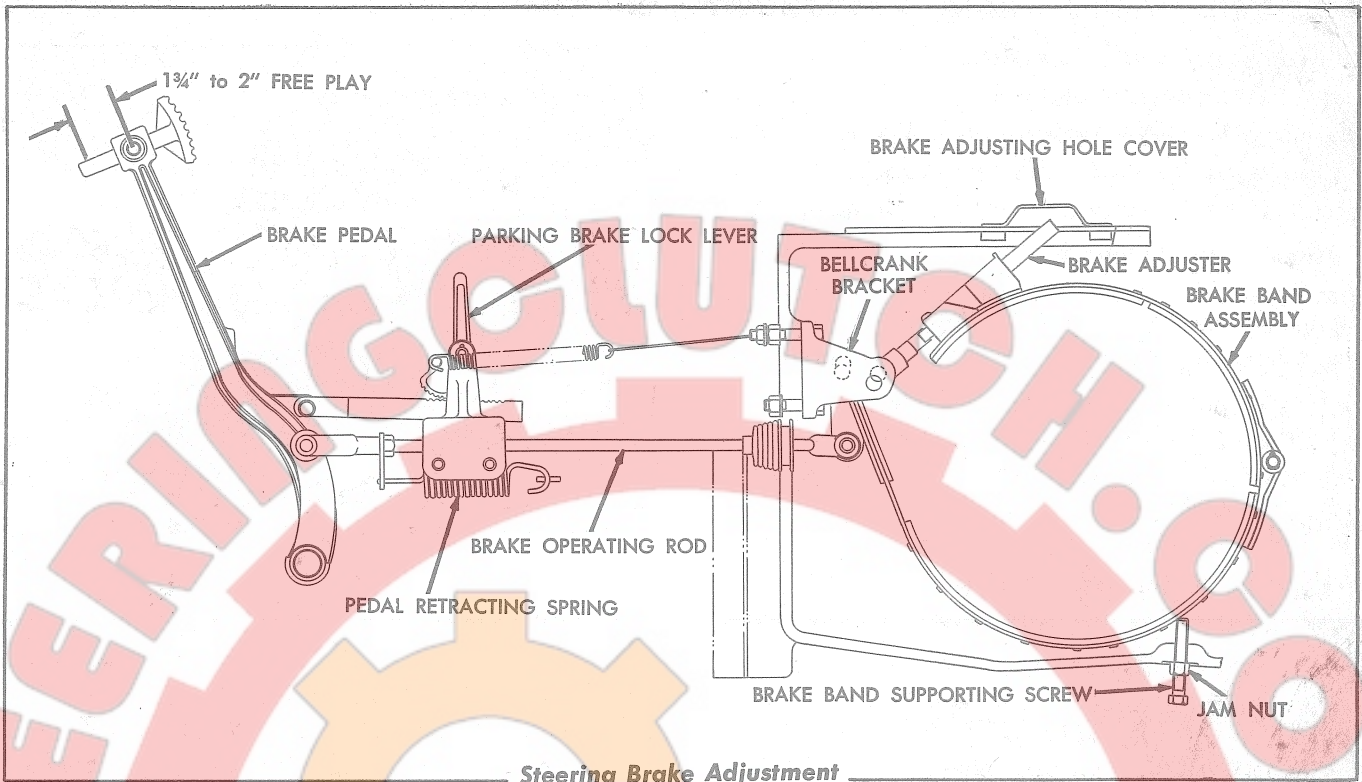

FIG. 54

## TRACK AND TRACK IDLER ADJUSTMENT

The tracks are properly adjusted when the upper part of the tracks can be pried up  $1\frac{1}{2}$ " to 2" above the support rollers with the use of a pry bar. Proper adjustment is important because rapid wear will occur on the tracks and other affected parts if the tracks are too tight or too loose.

To adjust each track, loosen the lock capscrews in the adjusting screw lock, then turn the adjusting screw out of the idler yoke as necessary to force the track idler ahead and tighten the track, or turn the screw into the yoke as necessary to loosen the track. Drive the tractor forward and backward a few times, then check the adjustment of the track. When the correct adjustment of the track is obtained, tighten the lock capscrews in the adjusting screw lock.

Inspect the track idler upper and lower slide bars. If they are worn excessively, they must be turned to renew the wearing surfaces or replaced. Add or remove the shims between the lower slide bars and the truck frames to provide a sliding fit between the track idler brackets and the slide bars.

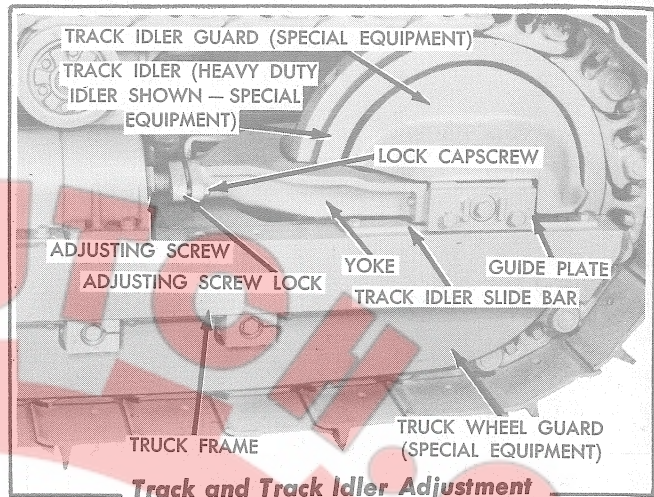

FIG. 55

If the track idler flange is wearing unevenly or cutting on one side, because it is not centered in the track rail assembly, adjust. Remove the track idler guide plates and move sufficient shims from the side which shows no wear to the side which shows excessive wear. Reinstall the guide plates.

## PREPARATION OF TRACTOR FOR STORAGE

If the tractor is to be stored during the winter or slack season, make a complete inspection of the tractor for loose, worn, or damaged parts and make the necessary repairs before it is stored.

Drain the engine crankcase and all other oil compartments and refill them with new oil. To protect the fuel injection system, drain the fuel tank, then pour about 10 gallons of a mixture of 40% mineral oil and 60% "Perfection Kerosene" in the fuel tank and run the engine for 15 minutes to circulate this mixture through the fuel system. This will leave the fuel system filled with the mixture and will prevent corrosion or gumming of the working parts. Major oil companies can supply this storage fuel mixture.

After the tractor has been stored, fill the fuel tank with the specified "DIESEL" fuel to minimize condensation in the tank. *NOTE: This fuel need not be drained when the tractor is again placed in service.*

Remove the batteries, clean, and store them in a cool, dry place (refer to "ELECTRICAL SYSTEM"). Test them once a month and recharge them if the specific gravity of the electrolyte falls below 1.215. Keep the specific gravity of the electrolyte above 1.220 to prevent the batteries from freezing.

Drain the cooling system or fill it with an anti-freeze solution that will withstand the lowest anticipated temperature. Cover the exhaust pipe.

