

FINAL DRIVE PINION SHAFT

* 44" tread Models
 ** 60" tread Models

ITEM	PART NUMBER	QUANTITY	DESCRIPTION	KIT NUMBER
		* **		
1	050216	2 2	DRUM, brake	
2	049937	- 2	HUB, brake drum	
3	035221	- 16	CAPSCREW, 1/2"NC x 1"	
	904208	- 16	LOCKWASHER, 1/2"	
4	050264	- 2	SEAL, oil (neoprene)	
5	050226	- 2	CAPSCREW, hub retaining (1"NF x 1-3/4")	
6	050225	- 2	WASHER, locking, hub retaining capscrow	
7	064520	- 2	WASHER ASSEMBLY, hub retaining (Includes item 8)	
8	035793	- 2	PIN, hub retaining washer	
9	053670	2 2	SEAL, oil	032785
10	049820	2 2	CAGE, inner bearing	
11	013058	12 12	CAPSCREW, 3/8"NC x 1-1/4"	
	904206	12 12	- LOCKWASHER, 3/8"	
12	051245	2 2	GASKET, inner bearing cage	069625
13	050274	2 2	BEARING, roller, inner	
14	049945	- 2	SHAFT (When making first replacement on tractors prior to #1630 also furnish WASHER ASSEMBLY 064520)	
15	040831	- 2	RING, snap, intermediate bearing	
16	063912	- 2	BEARING, roller, intermediate	
17	049899	2 2	RING, snap, pinion shaft	

(Continued)

FINAL DRIVE PINION SHAFT (Continued)

ITEM	PART NUMBER	QUANTITY	DESCRIPTION	KIT NUMBER
18	049881	2	PINION (20 teeth)	
19	050273	2	BEARING, roller, outer	
20	049903	2	GASKET, outer bearing cover	069625
21	049818	2	COVER, outer bearing	
22	013058	8	CAPSCREW, 3/8"NC x 1-1/4"	
	904206	8	LOCKWASHER, 3/8"	
23	049822	2	HUB, brake drum	
24	207781	16	CAPSCREW, 1/2"NC x 1" (thin head)	
	904208	16	LOCKWASHER, 1/2"	

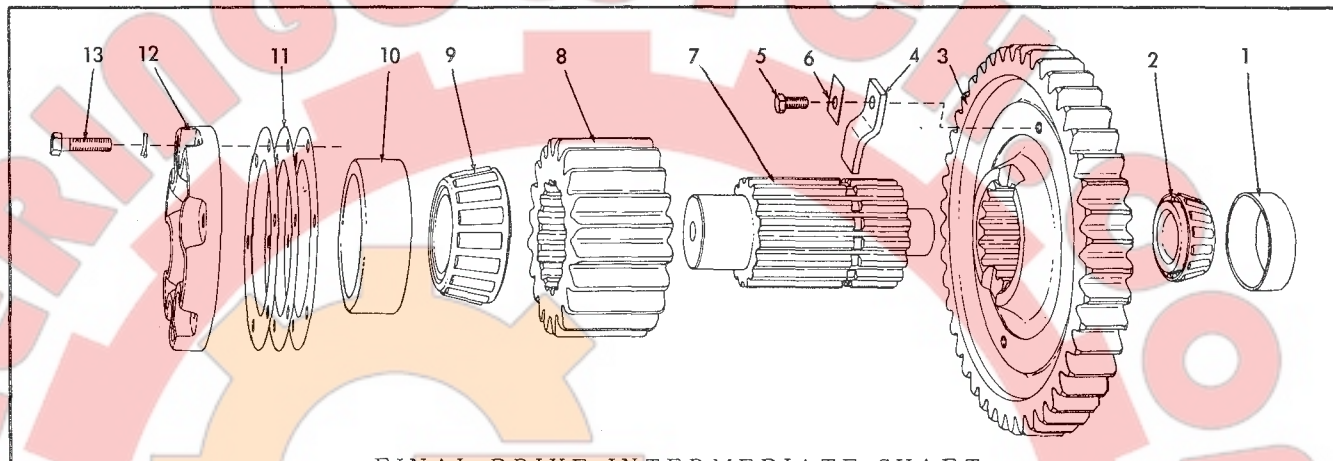

FINAL DRIVE INTERMEDIATE SHAFT

ITEM	PART NUMBER	QTY.	DESCRIPTION	KIT NUMBER
1	050275	2	CUP, inner bearing	
2	064200	2	CONE ASSEMBLY, inner bearing	
3	068501	2	GEAR (44 teeth)(When making first replacement on tractors prior to #6893 also furnish 2 CAPSCREWS 035244)	
4	049829	4	LOCK, gear retaining	
5	036032	4	CAPSCREW, 3/8"NF x 3/4" (Used on tractors prior to #6893)	
6	035244	4	CAPSCREW, 3/8"NC x 3/4" (Used on tractors #6893 and up)	
6	049936	4	LOCK, capscrew	
7	051246	2	SHAFT	
8	049886	2	PINION (20 teeth)	
9	051438	2	CONE ASSEMBLY, outer bearing	
10	051347	2	CUP, outer bearing	
11	051450	4	SHIM, bearing adjustment (.005" thick. Use as req'd)	
	051448	4	SHIM, bearing adjustment (.007" thick. Use as req'd)	
	051449	10	SHIM, bearing adjustment (.010" thick. Use as req'd)	
12	051243	2	COVER, inner bearing	
13	013058	12	CAPSCREW, 3/8"NC x 1-1/4"	
	904206	12	LOCKWASHER, 3/8"	

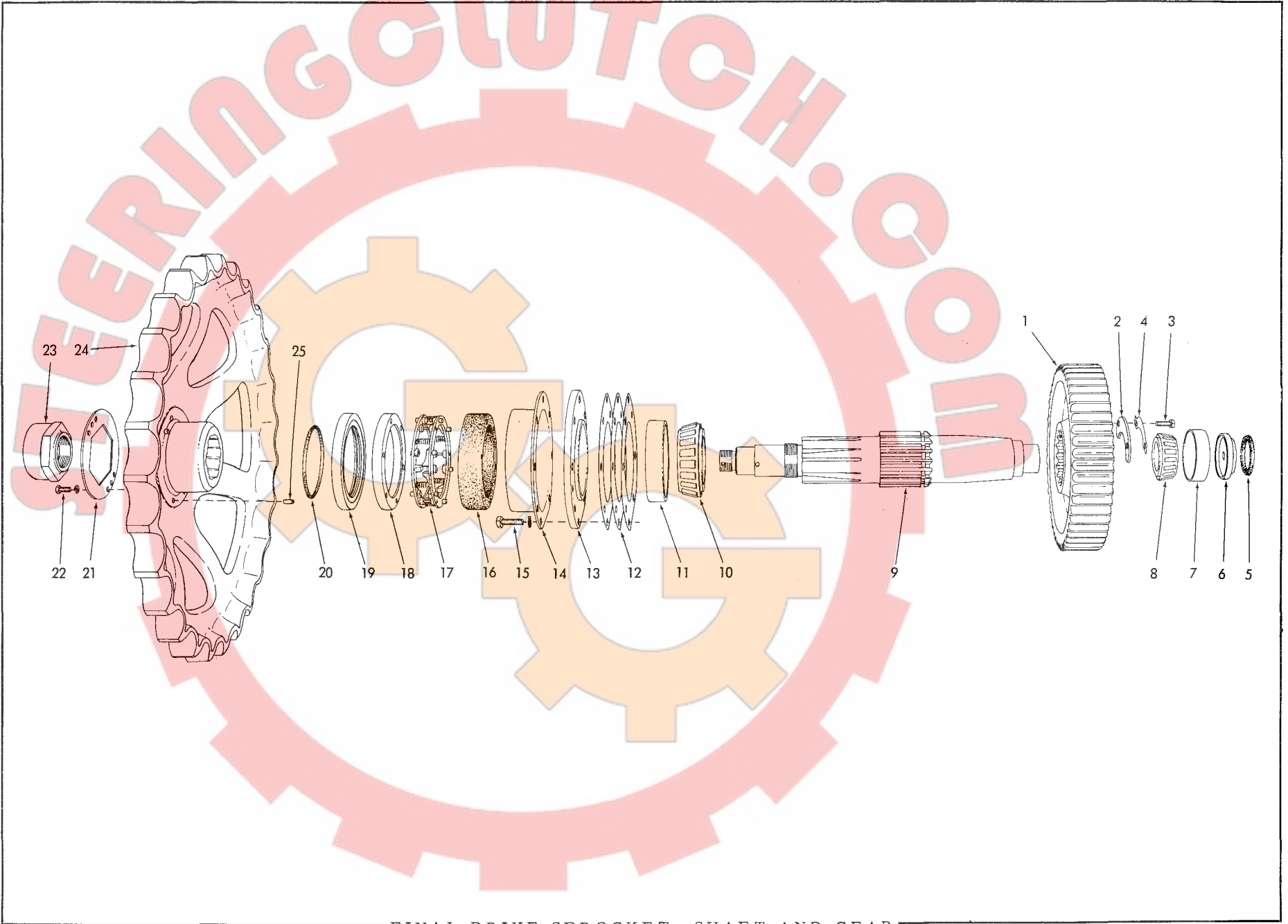

FINAL DRIVE SPROCKET, SHAFT AND GEAR

FINAL DRIVE SPROCKET, SHAFT AND GEAR

ITEM	PART NUMBER	QTY.	DESCRIPTION	KIT NUMBER
1	051400	2	GEAR (51 teeth)	
2	051395	2	LOCK, gear retaining	
3	036034	4	CAPSCREW, 3/8"NF x 1"	
4	051396	2	LOCK, capscrew	081460
5	051238	2	SEAL, shaft end cover	
6	049834	2	COVER, shaft end, inner	
7	210740	2	CUP, inner bearing	
8	043491	2	CONE ASSEMBLY, inner bearing	
9	076709	2	SHAFT, track sprocket (6 splines)(For tractors prior to #22985. Used with FIRST TYPE OUTBOARD BEARING ARRANGEMENT only. When making first replacement on tractors prior to #4126 furnish SHAFT KIT 066258)	066258
	080954	2	SHAFT, track sprocket (6 splines)(Tractors #22985 and up. Used with SECOND TYPE OUTBOARD BEARING ARRANGEMENT only)	081460
10	621238	2	SHAFT, track sprocket (20 splines)(Used for replacement only)	
	050278	2	CONE ASSEMBLY, intermediate bearing (3-1/4" I.D.) (Original equipment)	
	179826	2	CONE ASSEMBLY, intermediate bearing (3-3/8" I.D.) (Service replacement. Used with 20-spline shaft only)	
11	050276	2	CUP, intermediate bearing	
12	051240	4	SHIM, bearing adjustment (.005" thick. Use as req'd)	081460
	051241	4	SHIM, bearing adjustment (.007" thick. Use as req'd)	081460
	051242	16	SHIM, bearing adjustment (.010" thick. Use as req'd)	
13	051244	2	RETAINER, intermediate bearing	
14	049851	2	GUARD, inner seal	
15	035190	16	CAPSCREW, 1/2"NC x 1-1/2"	
	904208	16	LOCKWASHER, 1/2"	
16	049826	2	BOOT, inner seal	073762
17	049825	2	FOLLOWER ASSEMBLY, inner seal (Serviced only as a unit).	073762
18	082883	2	RING, inner seal (stationary, 5" I.D.)(Original equipment)	073762
	096158	2	RING, inner seal (stationary, 5-1/16" I.D.)(Service replacement only. Required with 20-spline track sprocket)	

23 PIN 066117
 UN 76709

(Continued)

FINAL DRIVE SPROCKET, SHAFT AND GEAR (Continued)

ITEM	PART NUMBER	QTY.	DESCRIPTION	KIT NUMBER
19	082859	2	RING, inner seal (rotating, 6-13/16"O. D.)(Original equipment)	073762
	096159	2	RING, inner seal (rotating, 7-1/2"O. D.)(Service replacement only. Required with 20-spline track sprocket)	
20	053594	2	RING, packing, seal ring (rubber, 4-15/16"I. D.) (Original equipment)	073762
	096160	2	RING, packing, seal ring (rubber, 5-5/8"I. D.) (Service replacement only. Required with 20-spline track sprocket)	
21	049853	2	LOCK, sprocket retaining nut (3-3/4"hex)(Original equipment)	
	621243	2	LOCK, sprocket retaining nut (4"(hex)(Service replacement only. Required with 20-spline track sprocket)	
22	035439	4	CAPSCREW, 3/8"NC x 1"	
	904206	4	LOCKWASHER, 3/8"	
23	-----	-	NUT, sprocket retaining (See FINAL DRIVE OUT-BOARD BEARING AND SEAL)	
24	049817	2	<i>029590 → 6 29587 + PINS</i> SPROCKET ASSEMBLY, track (6 splines. Includes item 25)(Standard. Has flat tooth-base)(Original equipment)	
	056188	2	<i>056154 → 6 29587</i> SPROCKET ASSEMBLY, track (6-splines. Includes item 25)(Special. Has skeleton tooth-base to minimize packing of track)	
	621237	2	SPROCKET ASSEMBLY, track (20-splines. Includes item 25)(Service replacement only)	
	097960	2	SPROCKET RIM only (Standard type. Requires welding to install)	
	25	042930	6	