

SUMMARY OF MAJOR SECTIONS - INDICE DELLE SEZIONI PRINCIPALI - INDEX DES SECTIONS PRINCIPALES
 INHALT DER HAUPTABSCHNITTE - INDICE DE LOS CAPITULOS PRINCIPALES

A	ENGINE • MOTORE • MOTEUR • MOTOR • MOTOR
B	MECHANICAL TRANSMISSION • CLUTCH • TRANSMISSION • TRANSMISSION SHAFT • AXLES TRASMISSIONE MECCANICA • FRIZIONE • CAMBIO • ALBERO DI TRASMISSIONE • PONTI TRANSMISSION MECANIQUE • EMBRAYAGE • BOITE DE VITESSES • ARBRE DE TRANSMISSION • PONTIS MECHANISCHE KRAFTÜBERTRAGUNG • KUPPLUNG • GETRIEBE • GELENKWELLE • ACHSEN TRANSMISSION MECANICA • EMBRAGUE • CAMBIO • ARBOL DE TRANSMISSION • PUENTES
C	BRAKES (MECHANICAL OR HYDRAULIC) • FRENI (MECCANICI O IDRAULICI) • FREINS (MECANIQUES OU HYDRAULIQUES) • BREMSEN (MECHANISCHE ODER HYDRAULISCHE) • FRENOS (MECANICOS O HYDRAULICOS)
D	FRAME • STEERING • SUSPENSIONS • WHEELS • UNDERCARRIAGE • HYDRAULIC TRANSMISSION TELAIO • STERZO • SOSPENSIONI • RUOTE • CINGOLATURA • TRASMISSIONE IDRAULICA CADRE • DIRECTION • SUSPENSIONS • ROUES • TRAIN DE ROULEMENT • TRANSMISSION HYDRAULIQUE RAHMEN • LENKUNG • AUFHÄNGUNGEN • RÄDER • KETTENLAUFWERK • HYDRAULISCHER ANTRIEB BASTIDOR • DIRECCIÓN • SUSPENSIÓN • RUEDAS • TREN DE RODAJE • TRANSMISIÓN HIDRÁULICA
E	AUXILIARY ATTACHMENT (AND EQUIPMENT) • ORGANI SUSSIDIARI (E ATTREZZI) • ORGANES AUXILIAIRES (ET EQUIPEMENT) • NEBENAGGREGATE (UND GERÄTE) • GRUPOS AUXILIARES (Y EQUIPO)
F	ELECTRICAL SYSTEM • IMPIANTO ELETTRICO • SYSTEME ELECTRIQUE • ELEKTRISCHE ANLAGE • SISTEMA ELETTRICO
G	AIR SYSTEM • IMPIANTO PNEUMATICO • SYSTEME PNEUMATIQUE • DRUCKLUFTANLAGE • SISTEMA NEUMATICO
H	TOOLS • ATTREZZI • OUYILLAGES • WERKZEUGE • UTILES
L	BODY • CARROZZERIA • CARROSSERIE • AUFBAU • CARROCCERIA
M	DRIVER'S SEAT • SEDILE CONDUTTORE • SIEGE DE CONDUCTEUR • FAHRERSITZ • BUTACA DE CONDUCTOR
X	LIST OF CANCELLED PARTS IN THIS UPDATING • ELENCO PARTICOLARI SOPPRESSI NEL PRESENTE AGGIORNAMENTO • LISTE DES PIECES ANNULEES DANS CETTE MISE A JOUR • LISTE DER ANNULLIERTEN TEILE AUF DER GEGENWÄRTIGEN ABÄNDERUNG • LISTA DE LAS PIECAS CANCELADAS EN LA PRESENTE REVISION
Y	LIST OF NEW PARTS ADDED IN THIS UPDATING • ELENCO PARTICOLARI NUOVI AGGIUNTI NEL PRESENTE AGGIORNAMENTO • LISTE DES NOUVELLES PIECES AJOUTEES DANS CETTE MISE A JOUR • LISTE DER NEUEN HINZUGEFUGTEN TEILE AUF DER GEGENWÄRTIGEN ABÄNDERUNG • LISTA DE LAS PIECAS NUEVAS ANADIDAS EN LA PRESENTE REVISION
W	SUMMARY OF MODIFIED PARTS • RIPILOGO PARTICOLARI MODIFICATI • RECAPITULATIF DES PIECES MODIFIEES • ZUSAMMEN- FASSUNG DER VERÄNDERTEN TEILE • RECAPITULACION DE LAS PIECAS MODIFICADAS

FIATALLIS FD7

NTR. 205 30.09.01 - 60401081.06

SUBGROUPS RESEARCH INDEX ON THE FICHES - INDICE DI RICERCA DEI SOTTOGRUPPI SULLE FICHES
INDEX DE RECHERCHE DES SOUS-GROUPES SUR LES FICHES - SUCHINDEX DER UNTERGRUPPEN AUF KARTE
INDICE DE LOCALIZACION DE LOS SUBGRUPOS EN LAS FICHAS

SGR.	TAV.	PAG.	GRID	SGR.	TAV.	PAG.	GRID	SGR.	TAV.	PAG.	GRID
A0.00	1	1	1-H2	A1.25	1	1	1-I3	A2.27	2	1	1-M5
A0.02	1	1	1-H3	A2.01	1	1	1-I2	A2.27	2	2	1-M4
A1.01	1	1	1-H4	A2.01	1	2	1-L2	A2.27/ A	1	1	1-M3
A1.01	2	1	1-H5	A2.21	1	1	1-L3	A2.27/ A	2	1	1-M2
A1.01/ A	1	1	1-H6	A2.21	1	2	1-L4	A2.27/ A	3	1	1-N2
A1.01/ A	2	1	1-H7	A2.21	1A	1	1-L5	A2.27/ A	4	1	1-N3
A1.01/ A	2	2	1-H8	A2.21	1A	2	1-L6	A2.28	1	1	1-N4
A1.02	1	1	1-H9	A2.21	2	1	1-L7	A2.28	2	1	1-N5
A1.02	1	2	1-H10	A2.22	1	1	1-L8	A2.28	2	2	1-N6
A1.02	2	1	1-H11	A2.22	1	2	1-L9	A2.28	3	1	1-N7
A1.02	2A	1	1-H12	A2.22/ 1	1	1	1-L10	A2.33	1	1	1-N8
A1.03	1	1	1-H13	A2.22/ 2	1	1	1-L11	A2.33	1	2	1-N9
A1.03/ A	1	1	1-H14	A2.23	1	1	1-L12	A2.35	1	1	1-N10
A1.04	1	1	1-H15	A2.23/ 1	1	1	1-L13	A2.35/ A	1	1	1-N11
A1.05	1	1	1-H16	A2.23/ 2	1	1	1-L14	A2.35/ A	1	2	1-N12
A1.05	1	2	1-H17	A2.24	1	1	1-L15	A2.35/ 1	1	1	1-N13
A1.05/ A	1	1	1-I17	A2.24	2	1	1-L16	A2.35/ 1A	1	1	1-N14
A1.06	1	1	1-I16	A2.24	3	1	1-L17	A2.35/ 2	1	1	1-N15
A1.06/ A	1	1	1-I15	A2.24	3	2	1-M17	A2.35/ 2A	1	1	1-N16
A1.07	1	1	1-I14	A2.24	4	1	1-M16	A2.35/ 3	1	1	1-N17
A1.07	1	2	1-I13	A2.24/ A	1	1	1-M15	A2.37	1	1	1-O17
A1.07/ A	1	1	1-I12	A2.24/ A	2	1	1-M14	A2.37	1	2	1-O16
A1.07/ A	1	2	1-I11	A2.24/ A	3	1	1-M13	A2.54	1	1	1-O15
A1.08	1	1	1-I10	A2.24/ A	4	1	1-M12	A2.54	1	2	1-O14
A1.08/ A	1	1	1-I9	A2.25	1	1	1-M11	A2.56	1	1	1-O13
A1.08/ A	1	2	1-I8	A2.25/ A	1	1	1-M10	A3.01	1	1	1-O12
A1.15	1	1	1-I7	A2.26	1	1	1-M9	A3.01	1A	1	1-O11
A1.15/ A	1	1	1-I6	A2.26/ A	1	1	1-M8	A3.01	2	1	1-O10
A1.16	1	1	1-I5	A2.27	1	1	1-M7	A3.01	2A	1	1-O9
A1.16/ A	1	1	1-I4	A2.27	1	2	1-M6	A3.01	3	1	1-O8

FIATALLIS F107

NTR. 205 30.09.91 - 60401081.06

SGR.	TAV.	PAG.	GRID	SGR.	TAV.	PAG.	GRID	SGR.	TAV.	PAG.	GRID
A3.02	1	1	1-O7	B2.01	6	1	1-Q9	B2.01/ B	10	1	1-S11
A4.01	1	1	1-O6	B2.01	6	2	1-Q8	B2.01/ B	11	1	1-S10
A4.01	1	2	1-O5	B2.01	7	1	1-Q7	B2.01/ B	11	2	1-S9
A4.01	2	1	1-O4	B2.01	7	2	1-Q6	B2.01/ 1	1	1	1-S8
A4.01	3	1	1-O3	B2.01/ A	1	1	1-Q5	B2.01/ 1	1	2	1-S7
A4.02	1	1	1-O2	B2.01/ A	1	2	1-Q4	B2.01/ 1	2	1	1-S6
A4.02	1	2	1-P2	B2.01/ A	2	1	1-Q3	B2.01/ 1	2	2	1-S5
A4.02	2	1	1-P3	B2.01/ A	2	2	1-Q2	B2.01/ 1	3	1	1-S4
A4.02	2	2	1-P4	B2.01/ A	3	1	1-R2	B2.01/ 1	3	2	1-S3
A4.02	2	3	1-P5	B2.01/ A	3	2	1-R3	B2.01/ 1	4	1	1-S2
A4.02	2A	1	1-P6	B2.01/ A	4	1	1-R4	B2.01/ 1	4	2	1-T2
A4.02	3	1	1-P7	B2.01/ A	5	1	1-R5	B2.01/ 1	5	1	1-T3
A4.03	1	1	1-P8	B2.01/ A	6	1	1-R6	B2.01/ 1	6	1	1-T4
A4.03/ A	1	1	1-P9	B2.01/ A	6	2	1-R7	B2.01/ 1	6	2	1-T5
A4.04	1	1	1-P10	B2.01/ A	7	1	1-R8	B2.01/ 1	7	1	1-T6
A4.09	1	1	1-P11	B2.01/ A	7	2	1-R9	B2.01/ 1	7	2	1-T7
A4.09	1	2	1-P12	B2.01/ B	1	1	1-R10	B2.01/ 1A	1	1	1-T8
A4.09/ 1	1	1	1-P13	B2.01/ B	1	2	1-R11	B2.01/ 1A	1	2	1-T9
B2.00	1	1	1-P14	B2.01/ B	2	1	1-R12	B2.01/ 1A	2	1	1-T10
B2.00	2	1	1-P15	B2.01/ 3	2	2	1-R13	B2.01/ 1A	2	2	1-T11
B2.00	2	2	1-P16	B2.01/ B	3	1	1-R14	B2.01/ 1A	3	1	1-T12
B2.01	1	1	1-P17	B2.01/ B	4	1	1-R15	B2.01/ 1A	4	1	1-T13
B2.01	1	2	1-Q17	B2.01/ B	5	1	1-R16	B2.01/ 1A	5	1	1-T14
B2.01	2	1	1-Q16	B2.01/ B	5	2	1-R17	B2.01/ 1A	5	2	1-T15
B2.01	2	2	1-Q15	B2.01/ B	6	1	1-S17	B2.01/ 1A	6	1	1-T16
B2.01	3	1	1-Q14	B2.01/ B	7	1	1-S16	B2.01/ 1A	7	1	1-T17
B2.01	3	2	1-Q13	B2.01/ B	7	2	1-S15	B2.01/ 1A	7	2	2-H2
B2.01	4	1	1-Q12	B2.01/ B	8	1	1-S14	B2.01/ 1A	8	1	2-H3
B2.01	4	2	1-Q11	B2.01/ B	9	1	1-S13	B2.01/ 1A	9	1	2-H4
B2.01	5	1	1-Q10	B2.01/ B	9	2	1-S12	B2.01/ 1A	9	2	2-H5

FIATALLIS FD7

NTR. 205 30.09.91 - 60401081.06

SGR.	TAV.	PAG.	GRID	SGR.	TAV.	PAG.	GRID	SGR.	TAV.	PAG.	GRID
B2.01/ 1A	10	1	2-H6	C1.01	2	1	2-L4	D3.34	1	2	2-N2
B2.01/ 1A	11	1	2-H7	C1.01	2	2	2-L5	D3.34	2	1	2-N3
B2.01/ 1A	11	2	2-H8	C1.35	1	1	2-L6	D3.37	1	1	2-N4
B2.06	1	1	2-H9	C1.35/ A	1	1	2-L7	D3.38	1	1	2-N5
B2.06	1	2	2-H10	D1.01	1	1	2-L8	D3.40	1	1	2-N6
B2.06	2	1	2-H11	D1.03	1	1	2-L9	D3.40/ A	1	1	2-N7
B2.07	1	1	2-H12	D1.03/ 1	1	1	2-L10	D3.40/ A	2	1	2-N8
B2.10	1	1	2-H13	D2.20	1	1	2-L11	D3.40/ 1	1	1	2-N9
B2.10	2	1	2-H14	D2.20	2	1	2-L12	E1.02	1	1	2-N10
B2.10	2	2	2-H15	D2.22	1	1	2-L13	E2.15	1	1	2-N11
B2.18	1	1	2-H16	D2.22	2	1	2-L14	E2.16	1	1	2-N12
B2.21	1	1	2-H17	D2.23	1	1	2-L15	E3.02	1	1	2-N13
B2.33	1	1	2-I17	D2.23	1	2	2-L16	E3.02	2	1	2-N14
B2.33/ A	1	1	2-I16	D2.23	1	3	2-L17	E3.02	2	2	2-N15
B2.34	1	1	2-I15	D2.23	2	1	2-M17	E3.02	3	1	2-N16
B2.34/ A	1	1	2-I14	D2.23	2	2	2-M16	E3.02	4	1	2-N17
B2.38	1	1	2-I13	D2.23	3	1	2-M15	E3.02	4A	1	2-O17
B3.01	1	1	2-I12	D2.23	3	2	2-M14	E3.02	5	1	2-O16
B3.16	1	1	2-I11	D2.24	1	1	2-M13	E3.02	5A	1	2-O15
B4.04	1	1	2-I10	D2.27	1	1	2-M12	E3.02	6	1	2-O14
B4.04	1	2	2-I9	D2.27/ A	1	1	2-M11	E3.02	6A	1	2-O13
B4.04/ A	1	1	2-I8	D2.29	1	1	2-M10	E3.02/ 1	1	1	2-O12
B4.04/ A	1	2	2-I7	D2.29	1	2	2-M9	E3.02/ 2	1	1	2-O11
B4.08	1	1	2-I6	D2.29	2	1	2-M8	E3.02/ 3	1	1	2-O10
B4.08	1	2	2-I5	D3.01	1	1	2-M7	E3.02/ 4	1	1	2-O9
B4.11	1	1	2-I4	D3.05	1	1	2-M6	E3.02/ 5	1	1	2-O8
B4.11	1	2	2-I3	D3.30	1	1	2-M5	E3.02/ 5	2	1	2-O7
B4.12	1	1	2-I2	D3.31	1	1	2-M4	E3.02/ 6	1	1	2-O6
B5.01	1	1	2-L2	D3.33	1	1	2-M3	E3.02/ 7	1	1	2-O5
C1.01	1	1	2-L3	D3.34	1	1	2-M2	E3.02/ 8	1	1	2-O4

FIATALLIS FD7

NTR. 205 30.09.91 - 60401081.06

SGR.	TAV.	PAG.	GRID	SGR.	TAV.	PAG.	GRID	SGR.	TAV.	PAG.	GRID
E3.02/ 9	1	1	2-O3	E3.13/ 4	1	1	2-Q5	F2.05	1	2	2-S7
E3.02/ 9	2	1	2-O2	E3.13/ 4	1	2	2-Q4	F2.05/ A	1	1	2-S6
E3.02/ 9	3	1	2-P2	E3.13/ 5	1	1	2-Q3	F3.01	1	1	2-S5
E3.02/10	1	1	2-P3	E3.13/ 5	1	2	2-Q2	F3.01	2	1	2-S4
E3.02/10	2	1	2-P4	E3.15	1	1	2-R2	F3.01	2A	1	2-S3
E3.02/10	3	1	2-P5	E3.25	1	1	2-R3	F3.03	1	1	2-S2
E3.02/11	1	1	2-P6	E3.25	2	1	2-R4	F3.03	1	2	2-T2
E3.02/12	1	1	2-P7	E3.28	1	1	2-R5	F3.03/ A	1	1	2-T3
E3.05	1	1	2-P8	E3.28	1	2	2-R6	F3.03/ 1	1	1	2-T4
E3.06	1	1	2-P9	E3.29	1	1	2-R7	F3.03/ 1A	1	1	2-T5
E3.10	1	1	2-P10	E3.31	1	1	2-R8	F4.01	1	1	2-T6
E3.10/ 1	1	1	2-P11	E3.31	1	2	2-R9	F4.01	1	2	2-T7
E3.10/ 2	1	1	2-P12	E3.31	2	1	2-R10	F4.01	2	1	2-T8
E3.10/ 3	1	1	2-P13	E3.31	2	2	2-R11	F4.01	2	2	2-T9
E3.10/ 4	1	1	2-P14	E3.31/ 1	1	1	2-R12	F4.01	2	3	2-T10
E3.10/ 5	1	1	2-P15	E3.32	1	1	2-R13	F4.01	3	1	2-T11
E3.10/ 6	1	1	2-P16	E3.32	1	2	2-R14	F4.01	4	1	2-T12
E3.10/ 6	2	1	2-P17	E3.32/ 1	1	1	2-R15	F4.01	4	2	2-T13
E3.10/ 7	1	1	2-Q17	E3.32/ 2	1	1	2-R16	F4.01/ A	1	1	2-T14
E3.10/ 7	1	2	2-Q16	E3.32/ 3	1	1	2-R17	F4.01/ A	2	1	2-T15
E3.10/ 8	1	1	2-Q15	E3.32/ 4	1	1	2-S17	F4.01/ 1	1	1	2-T16
E3.10/ 8	1	2	2-Q14	E3.32/ 4	1	2	2-S16	F4.01/ 1A	1	1	2-T17
E3.10/ 8	1	3	2-Q13	E3.32/ 5	1	1	2-S15	F4.01/ 2	1	1	3-H2
E3.10/ 9	1	1	2-Q12	E3.32/ 6	1	1	2-S14	F4.01/ 2A	1	1	3-H3
E3.10/ 9	1	2	2-Q11	E3.32/ 6	1	2	2-S13	F4.01/ 2A	1	2	3-H4
E3.13	1	1	2-Q10	E3.32/ 7	1	1	2-S12	F4.05	1	1	3-H5
E3.13/ 1	1	1	2-Q9	E3.32/ 8	1	1	2-S11	F5.01	1	1	3-H6
E3.13/ 2	1	1	2-Q8	E3.34	1	1	2-S10	F5.01/ 1	1	1	3-H7
E3.13/ 3	1	1	2-Q7	F2.01	1	1	2-S9	F5.01/ 1A	1	1	3-H8
E3.13/ 3	1	2	2-Q6	F2.05	1	1	2-S8	F5.10	1	1	3-H9

FIATALLIS FD7

NTR. 205 30.09.91 - 60401081.06

SGR.	TAV.	PAG.	GRID	SGR.	TAV.	PAG.	GRID	SGR.	TAV.	PAG.	GRID
H1.01	1	1	3-H10	L1.30/ 1	1	1	3-L8				
H1.01	2	1	3-H11	L3.04	1	1	3-L9				
H1.01/ 1	1	1	3-H12	L3.04	1	2	3-L10				
H1.01/ 1	2	1	3-H13	L3.04	2	1	3-L11				
H1.01/ 2	1	1	3-H14	L3.08	1	1	3-L12				
H1.04	1	1	3-H15	L3.10	1	1	3-L13				
H1.04	2	1	3-H16	L3.10	2	1	3-L14				
L1.01	1	1	3-H17	L3.10	2	2	3-L15				
L1.01	1	2	3-I17	L3.10	3	1	3-L16				
L1.01	2	1	3-I16	L3.10	4	1	3-L17				
L1.01	2	2	3-I15	L3.10	5	1	3-M17				
L1.01	2	3	3-I14	L3.10/ 1	1	1	3-M16				
L1.01	3	1	3-I13	L3.10/ 1	2	1	3-M15				
L1.01	3	2	3-I12	L3.11		1	3-M14				
L1.01	4	1	3-I11	L3.11/ 1	1	1	3-M13				
L1.03	1	1	3-I10	L3.12	1	1	3-M12				
L1.03/ 1	1	1	3-I9	L4.10	1	1	3-M11				
L1.04	1	1	3-I8	L6.01	1	1	3-M10				
L1.04	1	2	3-I7	L6.01/ 1	1	1	3-M9				
L1.04	2	1	3-I6	L6.01/ 2	1	1	3-M8				
L1.04	3	1	3-I5	L6.04	1	1	3-M7				
L1.04	3	2	3-I4	M1.02	1	1	3-M6				
L1.04	4	1	3-I3								
L1.04	5	1	3-I2								
L1.04	6	1	3-L2								
L1.04	7	1	3-L3								
L1.04	8	1	3-L4								
L1.25	1	1	3-L5								
L1.30	1	1	3-L6								
L1.30/ A	1	1	3-L7								

ALPHABETICAL INDEX

DESCRIPTION	SGR.	TAV.	PAG.	GRID	DESCRIPTION	SGR.	TAV.	PAG.	GRID
ACCESSORIES	H1.04		1/ 1	3-H15/3-H16	CONNECTING RODS	A1.05/ A	1	1	1-H17
ADVANCE DEVICE	A2.24	1	1	1-L15	CONTROL, IMPLEMENT	E3.25		1/ 1	2-R3 /2-R4
AIR CLEANER, ENGINE	A2.22		1/ 2	1-L8 /1-L9	CONTROLS, GEARSHIFT INNER	B2.10		1/ 2	2-H13/2-H14/2-H15
ALTERNATOR	F3.01	2	1	2-S4	CONTRCLS, GEARSHIFT OUTER	B2.07		1	2-H12
ARMS, DOZER BLADE LIFTING	E3.10		1	2-P10	CRANKCASE	A1.01	1	1	1-H4
ARMS, DOZER BLADE LIFTING	E3.10/ 1		1	2-P11	CRANKCASE	A1.01/ A	1	1	1-H6
ARMS, DOZER BLADE LIFTING	E3.10/ 2		1	2-P12	CRANKCASE, FRONT COVER	A1.02	2	1	1-H11
ARMS, DOZER BLADE LIFTING	E3.10/ 3		1	2-P13	CRANKSHAFT	A1.03	1	1	1-H13
ARMS, DOZER BLADE LIFTING	E3.10/ 4		1	2-P14	CRANKSHAFT	A1.03/ A	1	1	1-H14
ARMS, DOZER BLADE LIFTING	E3.10/ 5		1	2-P15	CRANKSHAFT, BEARINGS	A1.03	1	1	1-H13
ARMS, DOZER BLADE LIFTING	E3.10/ 6		1/ 1	2-P16/2-P17	CRANKSHAFT, BEARINGS	A1.03/ A	1	1	1-H14
ARMS, IMPLEMENT LIFTING	E3.10		1	2-F10	CROSS BAR, TRACK FRAME	D3.31		1	2-M4
AUXILIARY ARRANGEMENTS	L1.30		1	3-L3	CYLINDER HEAD, COVERS	A1.01	2	1	1-H5
AUXILIARY ARRANGEMENTS	L1.30/ A		1	3-L7	CYLINDER HEAD, COVERS	A1.01/ A	2	1/ 2	1-H7 /1 H8
AUXILIARY ARRANGEMENTS	L1.30/ 1		1	3-L8	CYLINDER SLEEVE	A1.01	1	1	1-H4
BATTERIES	F3.01	1	1	2-S5	CYLINDER SLEEVE	A1.01/ A	1	1	1-H6
BELTS, FAN	A4.09	1	1/ 2	1-P11/1-P12	CYLINDER, BLADE ANGLE	E3.02/ 5	2	1	2-O7
BRAKE, BAND	C1.01	2	1/ 2	2-L4 /2-L5	CYLINDER, IDLER WHEEL	D3.34	1	1/ 2	2-M2 /2-N2
BRAKE, PEDALS	C1.01	1	1	2-L5	CYLINDER, LIFT	E3.02	5	1	2-O16
BRAND LOGO	L4.10		1	3-M11	CYLINDER, RIPPER	E3.02/ 2		1	2-O11
CAB	L1.03/ 1		1	3-I9	CYLINDER, TILT	E3.02/ 6		1	2-O8
CAB	L1.04		1/ 2/ 1	3-I8 /3-I7 /3-I6	DAMPER	A1.04		1	1-H15
			1/ 2/ 1	3-I5 /3-I4 /3-I3	DIAGNOSTIC SYSTEM	B5.01		1	2-L2
			1/ 1/ 1	3-I2 /3-L2 /3-L3	DIPSTCK, TRANSMISSION OIL	E2.06	2	1	2-H11
			1	3-L4	DIPSTCK, ENGINE OIL	A3.01	1	1	1-O12
CAB AND MOUNTINGS	L1.03		1	3-I10	DOZER BLADE, CYLINDER MOUNTS	E3.06		1	2-P9
CAMSHAFT	A1.07	1	1/ 2	1-H14/1-H13	DOZER, BLADE	E3.13/ 1		1	2-Q9
CAMSHAFT	A1.07/ A	1	1/ 2	1-H12/1-H11	DOZER, BLADE	E3.13/ 2		1	2-Q8
CAMSHAFT DRIVE	A1.06		1	1-H16	DRIVE GEARS, CENTRAL	B4.04		1/ 2	2-H10/2-I9
CAMSHAFT DRIVE	A1.06/ A		1	1-H15	DRIVE GEARS CENTRAL	B4.04/ A		1/ 2	2-I8 /2-I7
CLUTCHES, STEERING	D2.20		1/ 1	2-L11/2-L12	DRIVE MULTIMETER	A1.08		1	1-H10
CONNECTING RODS	A1.05	1	1/ 2	1-H16/1-H17	DRIVE MULTIMETER	A1.08/ A		1/ 2	1-I9 /1-I8

E
A8

DESCRIPTION	SGR.	TAV.	PAG.	GRID	DESCRIPTION	SGR.	TAV.	PAG.	GRID
DRIVES, AUXILIARY	A1.15	1		1-17	GUARDS, BOTTOM	L3.12	1		3-M12
DRIVES, AUXILIARY	A1.15/ A	1		1-16	HAND BRAKE, CONTROL	C1.35	1		2-L6
ENGINE	A0.00	1		1-H2	HAND BRAKE, CONTROL	C1.35/ A			2-L7
ENGINE STARTING EQUIPMENT	F2.01	1		2-S9	HEAD, CYLINDER	A1.01	2	1	1-H5
ENGINE, AIR PRE-CLEANER	A2.22	1/ 2		1-L8 /1-L9	HEAD, CYLINDER	A1.01/ A	2	1/ 2	1-H7 /1-H8
ENGINE, BREATHER PIPING	A1.25	1		1-13	HEADLAMP	F4.01/ A	2	1	2-T15
ENGINE, LUBRICATION	A3.01	1/ 1/ 1		1-O12/1-O11/1-O10	HEADLAMP	F4.01/ 1	1	1	2-T16
				1-09 /1-08	HEAT EXCHANGER, CONVERTER	B2.18		1	2-H16
ENGINE, SUSPENSIONS	A0.02	1		1-H3	HEAT EXCHANGER, ENGINE OIL	A3.01	2	1	1-O11
EXHAUST, PIPE	A2.56	1		1-O13	HEATER	E1.02		1	2-N10
FAN	A4.09	1	1/ 2	1-P11-1-P12	HOOD, ASSY	L1.01		1/ 2: 1	3-H17/3-H17/3-H16
FAN AND FAN DRIVE	A4.09/ 1	1	1	1-P13				2/ 3: 1	3-H15/3-H14/3-H13
FAN, DRIVE	A4.09	1	1/ 2	1-P11-1-P12				2: 1	3-H12,3-H11
FAN, TIGHTENER	A4.09	1	1/ 2	1-P11-1-P12	HYDRAULIC SYSTEM	E3.02	1	1/ 2	2-N13/2-N14/2-N15
FILTER, ENGINE OIL	A3.01	1	1	1-O12				1/ 1: 1	2-N16/2-N17/2-O17
FILTERS, FUEL	A2.24	3	1 2	1-L17/1-M*7				1/ 1: 1	2-O16/2-O15/2-O14
FILTERS, FUEL	A2.24/ A	3	1	1-M13				1	2-O13
FINAL DRIVE (REAR), MOUNTINGS	B4.11		1/ 2	2-14 /2-13	HYDRAULIC SYSTEM	E3.02/ 1	1		2-O12
FINAL DRIVE, (REAR) GEARS	B4.12		1	2-12	HYDRAULIC SYSTEM	E3.02/ 2	1		2-O11
FLYWHEEL	A1.03	1	1	1-H13	HYDRAULIC SYSTEM	E3.02/ 3	1		2-O10
FLYWHEEL	A1.03/ A	1		1-H14	HYDRAULIC SYSTEM	E3.02/ 4	1		2-O9
FLYWHEEL, HOUSING	A1.02	1	1/ 2	1-H9 /1-H10	HYDRAULIC SYSTEM	E3.02/ 5	1/ 1		2-O8 /2-O7
FOOTBOARDS	L3.04	2	1	3-L11	HYDRAULIC SYSTEM	E3.02/ 6	1		2-O6
FRAME	D1.01		1	2-L8	HYDRAULIC SYSTEM	E3.02/ 7	1		2-O5
FUEL LINES	A2.24/ A		1	1-M14	HYDRAULIC SYSTEM	E3.02/ 8	1		2-O4
GAUGE, ENGINE OIL TEMPERATURE	F5.10		1	3-H9	IDLER WHEEL	D3.34	2	1	2-N3
GAUGE, OIL PRESSURE (ENGINE)	F5.10		1	3-H9	IDLER WHEEL, SUPPORTS	D3.34	2	1	2-N3
GAUGE, OIL PRESSURE (TRANSMISSION)	F5.10		1	3-H9	IMPLEMENT, MOUNTS	E3.05		1	2-P8
GAUGE, TRANSMISSION OIL TEMPERATURE	F5.10		1	3-H9	INDICATORS, OPERATION	F5.10		1	3-H9
GENERATING SYSTEM	F3.01		1/ 1/ 1	2-S5 /2-S4 /2-S3	INJECTION PUMP, DRIVE	A1.16		1	1-15
GERMAN VERSION	F1.02		1	3-M6	INJECTION PUMP, DRIVE	A1.16/ A		1	1-14
GOVERNOR, SPEED	A2.24	1	1	1-L15	INTAKE PIPING	A2.22		1/ 2	1-L3 /1-L9

DESCRIPTION	SGR.	TAV.	PAG.	GRID	DESCRIPTION	SGR.	TAV.	PAG.	GRID
LAMP, DASH	F4.01/ A	1	1	2-T14	PUMP, STEERING CLUTCHES	D2.23	3	1/ 2	2-M15/2-M14
LAMP, REAR FLOOD	F4.01/ 1		1	2-T16	RADIATOR, ENGINE COOLANT	A4.01	1	1/ 2	1-06 /1-05
LAMP, REAR FLOOD	F4.01/ 1A		1	2-T17	RADIATOR, SHROUD	A4.01	2	1	1-04
LIGHTING SYSTEM	F4.01		1/ 2/ 1	2-T6 /2-T7 /2-T8	ROCKER ARMS	A1.07	1	1/ 2	1-114/1-113
			2/ 3/ 1	2-T9 /2-T10/2-T11	ROCKER ARMS	A1.07/ A	1	1/ 2	1-112/1-111
			1/ 2	2-T12/2-T13	ROPS CANOPY	L3.08		1	3-L12
LIGHTING SYSTEM	F4.01/ A		1/ 1	2-T14/2-T15	SCARIFIER, TEETH	E3.15		1	2-R2
LIGHTING SYSTEM	F4.01/ 1		1	2-T16	SEAT, PANELS	L3.10		1/ 1/ 2	3-L13/3-L14/3-L15
LIGHTING SYSTEM	F4.01/ 2		1	3-H2				1/ 1 1	3-L16/3-L17.3-M17
LIGHTING SYSTEM	F4.01/ 2A		1/ 2	3-H3 /3-H4	SEAT, PANELS	L3.10/ 1		1/ 1	3-M16/3-M15
LINKAGE, THROTTLE CONTROL	A2.21		1/ 2/ 1	1-L3 /1-L4 /1-L5	SEAT, DRIVER'S	L6.01		1	3-M10
			2/ 1	1-L6 /1-17	SEAT, DRIVER'S	L6.01/ 1		1	3-M9
MANIFOLD, EXHAUST	A2.54		1	1-O15/1-O14	SEAT, DRIVER'S	L6.01/ 2		1	3-M8
MANIFOLD, INTAKE	A2.54		1	1-O15/1-O14	SHAFT, SPROCKET	D3.33		1	2-M3
MUDGUARDS	L3.04		1	3-L9 /3-L10	SIGNALLING DEVICES	F5.01		1	3-H6
NOZZLE	A2.24		4	1-M16	SIGNALLING DEVICES	F5.01/ 1		1	3-H7
NOZZLE	A2.24/ A		4	1-M12	SIGNALLING DEVICES	F5.01 1A		1	3-H6
NOZZLE, HOLDER	A2.24		4	1-M16	SPROCKET	D3.33		1	2-M3
NOZZLE, HOLDER	A2.24/ A		4	1-M12	STARTER	F2.01		1	2-S9
PISTONS	A1.05		1	1-H16/1-H17	STEERING CLUTCH, CONTROL VALVE	D2.23		1	1/ 2/ 3
PISTONS	A1.05/ A		1	1-117	STEERING CLUTCH, HYDRAULIC CONTROL	E2.23		1/ 2/ 3	2-L15/2-L16/2-L17
PLATES, TYPE	L1.25		1	3-L5				1/ 2/ 1	2-M17/2-M16.2-M15
POWER TAKE-OFF	E2.16		1	2-N12				2	2-M14
PROPELLER SHAFT, TRANSMISSION-TO-AXLE	B3.01		1	2-H2	STEERING CLUTCH, LEVERS	D2.22		1	2-L13
PTO, CONTROL	E2.15		1	2-N11	STEERING CLUTCH, LINKAGE	D2.22		2	2-L14
PUMP, COOLANT	A4.02		2	1-P3 /1-P4 /1-P5	STEERING CLUTCH, LUBRICATION SYSTEM	D2.24		1	2-M13
PUMP, ENGINE OIL	A3.01		1	1-O12	SUMP, ENGINE OIL	A1.02		1	1-H9 /1-H10
PUMP, FUEL	A2.24		1	1-L15	SUSPENSION, FRONT	D3.01		1	2-M7
PUMP, FUEL	A2.24/ A		3	1-M13	SUSPENSION, REAR	D3.05		1	2-M6
PUMP, HYDRAULIC SYSTEM	E3.02		2	2-N14/2-N15	TANK (FUEL), LINES	A2.01		1/ 2	1-L1 /1-L2
PUMP, INJECTION	A2.24		1	1-L15	TANK FUEL	A2.01		1/ 2	1-12 /1-12
PUMP, INJECTION	A2.24/ A		1	1-M15	TANK, OIL	E3.28		1/ 2	2-F5 /2-R6

DESCRIPTION	SGR.	TAV.	PAG.	GRID	DESCRIPTION	SGR.	TAV.	PAG.	GRID
THERMOSTAT	A4.02	1	1/2	1-02 /1-P2					
TOOL BOX	L3.10	4	1	3-L17					
TOOLS	H1.01		1/1	3-H10/3-H11					
TOOLS	H1.01/ 1		1/1	3-H12/3-H13					
TOOLS	H1.01/ 2		1	3-H14					
TOWING DEVICE	D1.03		1	2-L9					
TOWING DEVICE	D1.03/ 1		1	2-L10					
TRACK	D3.40/ A		1/1	2-N7 /2-N8					
TRACK	D3.40/ 1		1	2-N9					
TRACK FRAME, BODY	D3.30		1	2-M5					
TRACK ROLLER	D3.37		1	2-N4					
TRACK ROLLER, CARRIER	D3.38		1	2-N5					
TRACK, GUARDS	L3.11		1	3-M14					
TRACK, GUARDS	L3.11/ 1		1	3-M13					
TRACK, LINKS	D3.40	1	1	2-N6					
TRACK, LINKS	D3.40/ A	1	1	2-N7					
TRACK LINKS	D3.40/ 1		1	2-N9					
TRACK, SHOES	D3.40	1	1	2-N6					
TRACK, SHOES	D3.40/ A	1	1	2-N7					
TRACK, SHOES	D3.40/ 1		1	2-N9					
TRANSMISSION	B2.00		1/ 1/ 2	1-P14/1-P15/1-P16					
TRANSMISSION (REAR), MOUNTING	B4.08	1	1/ 2	2-I6 /2-I5					
TRANSMISSION REAR COVERS	B4.08	1	1/ 2	2-I6 /2-I5					
TRANSMISSION, LOCK-UP DEVICE	B2.38		1	2-I13					
TRANSMISSION, LUBRICATION SYSTEM	B2.06		1/ 2 1	2-K9 /2-H10/2-H11					
VALVE	E3.34		1	2-S10					
VALVE, DIVERTOR	E3.02/ 1		1	2-O12					
VALVE, IDLER WHEEL ADJUSTMENT	D3.34	1	1/ 2	2-M2 /2-N2					
VALVE, MAIN CONTROL	E3.12	1	1	2-N13					
VALVES, ENGINE	A1.07	1	1/ 2	1-I14/1-I13					
VALVES, ENGINE	A1.07/ A	1	1/ 2	1-I12/1-I11					

INDICE ALFABETICO

DENOMINAZIONE	SGR.	TAV.	PAG.	GRID	DENOMINAZIONE	SGR.	TAV.	PAG.	GRID	
ACCESSORI	H1.04		1/1	3-H15/3-H16	CABINA	L1.04		1/1/1	3-12/3-12/3-L3	
ALBERO A CAMME	A1.07	1	1/2	1-H14/1-H13				1	3-L4	
ALBERO A CAMME	A1.07/ A	1	1/2	1-H12/1-H11	CABINA E SUPPORTI	L1.03		1	3-H10	
ALBERO MOTORE	A1.03	1	1	1-H13	CAMBIO DI VELOCITA'	B2.00		1/1/2	1-P14/1-P15/1-P16	
ALBERO MOTORE	A1.03/ A	1	1	1-H14	CANNA CILINDRI	A1.01	1	1	1-H4	
ALBERO RUOTA MOTRICE	D3.33	1	1	2-M3	CANNA CILINDRI	A1.01/ A	1	1	1-H6	
ALLESTIMENTO GERMANIA	M1.02		1	3-M6	CASSETTA PER ATTREZZI	L3.10	4	1	3-L17	
ALTERNATORE	F3.01	2	1	2-S4	CILINDRO ANGOLAZIONE LAMPA	E3.02/ 1		2	1	2-O7
ASTA LIVELLO OLIO CAMBIO	B2.06	2	1	2-H11	CILINDRO RIPPER	E3.02/ 2			1	2-O11
ASTA LIVELLO OLIO MOTORE	A3.01	1	1	1-O12	CILINDRO SOLLEVAMENTO	E3.02	5	1		2-O16
ATTREZZI	H1.01		1/1	3-H10/3-H11	CILINDRO TENDICINGOLO	D3.34	1	1/2		2-M2 2-N2
ATTREZZI	H1.01/ 1		1/1	3-H12/3-H13	CILINDRO TILT	E3.02/ 6				2-O6
ATTREZZI	H1.01/ 2		1	3-H14	CINGHIE VENTILATORE	A4.09	1	1/2		1-P11/1-L12
AVVIAMENTO MOTORE	F2.01		1	2-S9	CINGOLO	D3.40 A		1/1		2-N7 2-N8
BASAMENTO MOTORE	A1.01	1	1	1-H4	CINGOLO	D3.40 1		1		2-N9
BASAMENTO MOTORE	A1.01/ A	1	1	1-H6	COFANATURA	L1.01		1/2/1		3-H13/3-H17/3-H16
BATTERIE	F3.01	1	1	2-S5				2/3/1		3-H15/3-H14/3-H13
BIELLE	A1.05	1	1/2	1-H16/1-H17				2/1		3-12/3-11
BIELLE	A1.05/ A	1	1	1-H7	COLLEGAMENTO CARRELLI CINGOLI	D3.3		1		2-M4
BILANCIER VALVOLE	A1.07	1	1/2	1-H14/1-H13	COLLETTORI ASPIRAZIONE	A2.51	1	1/2		1-O15/1-O14
BILANCIER VALVOLE	A1.07/ A	1	1/2	1-H12/1-H11	COLLETTORE SCARICO	A2.51	1	1/2		1-O15/1-O14
BRACCI SOLLEVAMENTO APPRIPISTA	E3.10		1	2-P10	COMANDI / ACCELERATORE	A2.21		1/2/1		1-L3/1-L4/1-L5
BRACCI SOLLEVAMENTO APPRIPISTA	E3.10/ 1		1	2-P11				2/1		1-L6/1-L7
BRACCI SOLLEVAMENTO APPRIPISTA	E3.10/ 2		1	2-P12	COMANDI ESTERNI CAMBIO DI VELOCITA'	B2.7		1		2-H12
BRACCI SOLLEVAMENTO APPRIPISTA	E3.10/ 3		1	2-P13	COMANDI INTERNI CAMBIO DI VELOCITA'	B2.0		1/1/2		2-H13 2-H14/2-H15
BRACCI SOLLEVAMENTO APPRIPISTA	E3.10/ 4		1	2-P11	COMANDI VARI	A1.5		1		1-L7
BRACCI SOLLEVAMENTO APPRIPISTA	E3.10/ 5		1	2-P15	COMANDI VARI	A1.5/ A		1		1-H6
BRACCI SOLLEVAMENTO APPRIPISTA	E3.10/ 6		1/1	2-P16/2-P17	COMANDO A MANO FRENI	C1.15		1		2-L6
BRACCI SOLLEVAMENTO ATTREZZI	E3.10		1	2-P10	COMANDO A MANO FRENI	C1.35/ A		1		2-L7
CABINA	L1.03/ 1		1	3-H9	COMANDO ATTREZZO	E3.25		1/1		2-R3 2-R4
CABINA	L1.04		1/2/1	3-H8/3-17/3-16	COMANDO CRONOGIROMETRO	A1.08		1		1-10
			1/2/1	3-H5/3-14/3-13	COMANDO CRONOGIROMETRO	A1.03/ A		1/2		1-H9/1-H8

DENOMINAZIONE	SGR.	TAV.	PAG.	GRID	DENOMINAZIONE	SGR.	TAV.	PAG.	GRID
COMANDO DISTRIBUZIONE	A1.06		1	1-H6	ILLUMINAZIONE	F4.01		2/3/1	2-T9 /2-T10/2-T11
COMANDO DISTRIBUZIONE	A1.06/ A		1	1-H5				1/2	2-T12/2-T13
COMANDO IDRAULICO FRIZIONI DI STERZO	D2.23		1/2/3	2-L15/2-L16/2-L17	ILLUMINAZIONE	F4.01/ A		1/1	2-T14/2-T15
			1/2/1	2-M17/2-M16/2-M15	ILLUMINAZIONE	F4.01/ 1		1	2-T16
			2	2-M14	ILLUMINAZIONE	F4.01/ 2		1	3-H2
COMANDO POMPA INIEZIONE	A1.16		1	1-H5	ILLUMINAZIONE	F4.01/ 2A		1/2	3-H3 /3-H4
COMANDO POMPA INIEZIONE	A1.16/ A		1	1-H4	IMPIANTO IDRAULICO	E3.02		1/1/2	2-N13/2-N14/2-N15
COMANDO PRESA DI FORZA	E2.15		1	2-N11				1/1/1	2-N16/2-N17/2-O17
COMANDO VENTILATORE	A4.09	1	1/2	1-P11/1-P12				1/1/1	2-O16/2-O15/2-O14
CONVOLTORE RADIATORE	A4.01	2	1	1-O4				1	2-O13
COOPERCHI TESTA CILINDRI	A1.01	2	1	1-H5	IMPIANTO IDRAULICO	E3.02/ 1		1	2-O12
COOPERCHI TESTA CILINDRI	A1.01/ A	2	1/2	1-H7 /1-H8	IMPIANTO IDRAULICO	E3.02/ 2		1	2-O11
COOPERCHIO TRASMISSIONE POSTERIORE	B4.08	1	1/2	2-I6 /2-I5	IMPIANTO IDRAULICO	E3.02/ 3		1	2-O10
COOPERCHIO ANTERIORE BASAMENTO	A1.02	2	1	1-H11	IMPIANTO IDRAULICO	E3.02/ 4		1	2-O9
COPPA MOTORE	A1.02	1	1/2	1-H9 /1-H10	IMPIANTO IDRAULICO	E3.02/ 5		1/1	2-O8 /2-O7
CORPO CARRELLO CINGOLO	D3.36		1	2-M5	IMPIANTO IDRAULICO	E3.02/ 6		1	2-O6
CUSCINETTI ALBERO MOTORE	A1.03	1	1	1-H13	IMPIANTO IDRAULICO	E3.02/ 7		1	2-O5
CUSCINETTI ALBERO MOTORE	A1.03/ A	1	1	1-H14	IMPIANTO IDRAULICO	E3.02/ 8		1	2-O4
DENTI SCARIFICATORE	E3.15		1	2-R2	INTELLAIATURE PER SISTEMAZIONI VARIE	L1.30		1	3-L6
DEVIATORE IDRAULICO	E3.02/ 1		1	2-O12	INTELLAIATURE PER SISTEMAZIONI VARIE	L1.30/ A		1	3-L7
DIAGNOSTICA CENTRALIZZATA	B5.01		1	2-L2	INTELLAIATURE PER SISTEMAZIONI VARIE	L1.30/ 1		1	3-L8
DISPOSITIVO BLOCCAGGIO CAMBIO	B2.38		1	2-H3	LAMA APPRIPISTA	E3.13/ 1		1	2-Q9
DISTRIBUTORE FRIZIONI DI STERZO	D2.23	1	1/2/3	2-L15/2-L16/2-L17	LAMA APPRIPISTA	E3.13/ 2		1	2-Q8
DISTRIBUTORE PRINCIPALE	E3.02	1	1	2-N13	LEVE FRIZIONI DI STERZO	D2.22	1	1	2-L13
FANALE CRUSCOTTO	F4.01/ A	1	1	2-T11	LUBRIFICAZIONE CAMBIO	B2.06		1/2/1	2-H9 /2-H10/2-H11
FILTRI COMBUSTIBILE	A2.24	3	1/2	1-L17/1-M17	LUBRIFICAZIONE FRIZIONI DI STERZO	D2.24		1	2-M13
FILTRI COMBUSTIBILE	A2.24/ A	3	1	1-M13	LUBRIFICAZIONE MOTORE	A3.01		1/1/1	1-O'2/1-O11/1-O10
FILTRO ARIA MOTORE	A2.22		1/2	1-L8 /1-L9				1/1	1-C9 /1-C8
FILTRO OLIO LUBRIFICAZIONE MOTORE	A3.01	1	1	1-C12	MAGLIE CINGOLO	D3.40	1	1	2-N6
FRIZIONI DI STERZO	D2.20		1/1	2-L11/2-L12	MAGLIE CINGOLO	D3.40/ A		1	2-N7
GENERAZIONE DI CORRENTE	F3.01		1/1/1	2-S5 /2-S4 /2-S3	MAGLIE CINGOLO	D3.40/ 1		1	2-N9
ILLUMINAZIONE	F4.01		1/2/1	2-T6 /2-T7 /2-T8	MANOMETRO OLIO CAMBIO	F5.10		1	3-H9

DENOMINAZIONE	SGR.	TAV.	PAG.	GRID	DENOMINAZIONE	SGR.	TAV.	PAG.	GRID
MANOMETRO OLIO MOTORE	F5.10		1	3-H9	RIPARI SEDILE	L3.10		1/ 1/ 2	3-L13/3-L14/3-L15
MOTORE	A0.00		1	1-H2				1/ 1/ 1	3-L16/3-L17/3-M17
MOTORINO DI AVVIAMENTO	F2.01	1	1	2-S9	RIPARI SEDILE	L3.10/ 1		1/ 1	3-M16/3-M15
NASTRO DEL FRENO	C1.01	2	1/ 2	2-L4 /2-L5	RISCALDATORE	E1.02		1	2-N10
ORGANO DI TRAINO	D1.03		1	2-L9	RULLO CARRELLO CINGOLO	D3.37		1	2-N4
ORGANO DI TRAINO	D1.03/ 1		1	2-L10	RULLO SOSTEGNO CINGOLO	D3.38		1	2-N5
PARAFANGHI	L3.04	1	1/ 2	3-L9 /3-L10	RUOTA MOTRICE	D3.33		1	2-M3
PEDALI FRENI	C1.01	1	1	2-L3	RUOTA TENDICINGOLO	D3.34	2	1	2-N3
PEDANE	L3.04	2	1	3-L11	RUOTISMI RIDUTTORI LATERALI POSTERIORI	B4.12		1	2-I2
POLVERIZZATORE	A2.24	4	1	1-M16	RUOTISMI RIDUZIONE CENTRALE	B4.04		1/ 2	2-110/2-19
POLVERIZZATORE	A2.24/ A	4	1	1-M12	RUOTISMI RIDUZIONE CENTRALE	B4.04/ A		1/ 2	2-18 /2-17
POMPA ACQUA	A4.02	2	1/ 2/ 3	1-P3 /1-P4 /1-P5	SCAMBIATORE DI CALORE CONVERTITORE	B2.18		1	2-H13
POMPA ALIMENTAZIONE	A2.24	1	1	1-L15	SCAMBIATORE DI CALORE LUBRIFICAZIONE MOTORE	A3.01	2	1	1-C10
POMPA ALIMENTAZIONE	A2.24/ A	3	1	1-M13	SCATOLA TRASMISSIONE POSTERIORE	B4.08	1	1/ 2	2-R5 /2-15
POMPA FRIZIONI D. STERZO	D2.23	3	1/ 2	2-M15/2-M14	SCATOLA VOLANO	A1.02		1/ 2	1-H9 /1-H10
POMPA IMPIANTO IDRAULICO	E3.02	2	1/ 2	2-N14/2-N15	SCATOLE RIDUTTORI LATERALI POSTERIORI	B4.11		1/ 2	2-4 /2-13
POMPA INIEZIONE	A2.24	1	1	1-L15	SEDILE CONDUTTORE	L6.01		1	3-M10
POMPA INIEZIONE	A2.24/ A	1	1	1-M15	SEDILE CONDUTTORE	L6.01/ 1		1	3-M9
POMPA OLIO LUBRIFICAZIONE MOTORE	A3.01	1	1	1-O12	SEDILE CONDUTTORE	L6.01/ 2		1	3-M8
PORTAPOLVERIZZATORI	A2.24	4	1	1-M16	SEGNALAZIONI DI AVVISO	F5.01		1	3-H6
PORTAPOLVERIZZATORI	A2.24/ A	4	1	1-M12	SEGNALAZIONI DI AVVISO	F5.01/ 1		1	3-H7
PREFILTRO ARIA MOTORE	A2.22		1/ 2	1-L8 /1-L9	SEGNALAZIONI DI AVVISO	F5.01' 1A		1	3-H6
PRESA DI FORZA	E2.16		1	2-N12	SEGNALAZIONI DI FUNZIONAMENTO	F5.10		1	3-H9
PROIETTORE ANTERIORE	F4.01/ 1	2	1	2-T15	SERBATOIO COMBUSTIBILE	A2.01		1/ 2	1-I2 /1-L2
PROIETTORE ANTERIORE	F4.01' 1	1	1	2-T16	SERBATOIO OLIO	E3.28		1/ 2	2-R5 /2-R6
PROIETTORE POSTERIORE	F4.01' 1			2-T16	SIGLE MODELLI	L1.25		1	3-L5
PROIETTORE POSTERIORE	F4.01' 1A		1	2-T17	SMORZATORE PER ALBERO MOTORE	A1.04		1	1-H15
RADIATORE ACQUA MOTORE	A4.01	1	1/ 2	1-O6 /1-C6	SOSPENSIONE ANTERIORE	D3.01		1	2-M7
REGOLATORE DI VELOCITA'	A2.24	1	1	1-L15	SOSPENSIONE POSTERIORE	D3.05		1	2-M6
RIPARI CINGOLI	L3.11		1	3-M14	SOSPENSIONI MOTORE	A0.02		1	1-H5
RIPARI CINGOLI	L3.11' 1		1	3-M13	STANTUFFI	A1.05		1/ 2	1-H16/1-H17
RIPARI INFERIORI	L3.12		1	3-M12	STANTUFFI	A1.05/ A	1	1	1-H7

DENOMINAZIONE	SGR.	TAV.	PAG.	GRID	DENOMINAZIONE	SGR.	TAV.	PAG.	GRID
STRUTTURA DI PROTEZIONE ROPS	L3.08		1	3-L12					
SUOLE	D3.40	1	1	2-N6					
SUOLE	D3.40/ A	1	1	2-N7					
SUOLE	D3.40/ 1		1	2-N9					
SUPPORTI ATTREZZI	E3.05		1	2-P8					
SUPPORTI CILINDRI APRIPISTA	E3.06		1	2-P9					
SUPPORTI RUOTA TENDICINGOLO	D3.34	2	1	2-N3					
TARGHE	L4.10		1	3-M11					
TELAIO	D1.01		1	2-L8					
TENDICINGHIA VENTILATORE	A4.09	1	1/2	1-P11/1-P12					
TERMOMETRO OLIO CAMBIO	F5.10		1	3-H9					
TERMOMETRO OLIO MOTORE	F5.10		1	3-H9					
TERMOSTATO	A4.02	1	1/2	1-Q2 /1-P2					
TESTA CILINDRI	A1.01	2		1-H5					
TESTA CILINDRI	A1.01/ A	2	1/2	1-H7 /1-H8					
TIRANTERIA FRIZIONI DI STERZO	D2.22	2	1	2-L14					
TRASMISSIONE TRA CAMBIO E PONTE	B3.01		1	2-H2					
TUBAZIONE DI SCARICO	A2.56		1	1-O13					
TUBAZIONI ASPIRAZIONE	A2.22		1/2	1-L8 /1-L9					
TUBAZIONI COMBUSTIBILE	A2.24/ A	2	1	1-M14					
TUBAZIONI DAL SERBATOIO COMBUSTIBILE	A2.01		1/2	1-H2 1-L2					
TUBAZIONI PER AERAZIONE MOTORE	A1.25		1	1-B3					
VALVOLA	E3.34		1	2-S10					
VALVOLA REGISTRAZIONE TENDICINGOLO ..	D3.34	1	1/2	2-M2 2-N2					
VALVOLE DISTRIBUZIONE	A1.07	1	1/2	1-H14/1-H13					
VALVOLE DISTRIBUZIONE	A1.07/ A	1	1/2	1-H12/1-H11					
VALVATORE DI ANTICIPO	A2.24	1	1	1-L15					
VENTILATORE	A4.09	1	1/2	1-P11/1-P12					
VENTILATORE E SUO COMANDO	A4.09/ 1	1	1	1-P13					
VOLANO MOTORE	A1.03	1	1	1-H13					
VOLANO MOTORE	A1.03/ A	1	1	1-H14					

LISTE ALPHABETIQUE

DESIGNATION	SGR.	TAV.	PAG.	GRID	DESIGNATION	SGR.	TAV.	PAG.	GRID
ACCESSOIRES	H1.04		1/1	3-115/3-H16	CABINE	L1.04		1/1/1	3-12 /3-12 /3-L3
ACCOUPLMENT DE CHARIOTS DE CHENILLES	D3.31		1	2-M4				1	3-L4
AILES	L3.04	1	1/2	3-L9 /3-L10	CABINE ET SUPPORTS	L1.03		1	3-110
ALTERNATEUR	F3.01	2	1	2-S4	CANALISATION D'ECHAPPEMENT	A2.56		1	1-010
AMENAGEMENTS DIVERS	L1.30		1	3-L6	CAPOTAGE	L1.01		1/2/1	3-H17/3-H17/3-H16
AMENAGEMENTS DIVERS	L1.30/ A		1	3-L7				2/3/1	3-115/3-114/3-113
AMENAGEMENTS DIVERS	L1.30/ 1		1	3-L8				2/1	3-112/3-111
ARBRE A CAMES	A1.07	1	1/2	1-H14/1-H13	CARTER D'HUILE	A1.02	1	1/2	1-H9 /1-H10
ARBRE A CAMES	A1.07/ A	1	1/2	1-H12/1-H11	CARTER DE TRANSMISSION ARRIERE	B4.09	1	1/2	2-16 /2-15
ARBRE DE ROUE MOTRICE	D3.33	1	1	2-M3	CARTER DE VOLANT	A1.02	1	1/2	1-H9 /1-H10
AVERTISSEURS	F5.01		1	3-H6	CARTERS DE REDUCTEURS LATERAUX AR	B4.11		1/2	2-14 /2-13
AVERTISSEURS	F5.01/ 1		1	3-H7	CHASSIS	D1.01		1	2-L8
AVERTISSEURS	F5.01/ 1A		1	3-H8	CHASSIS DE CHARIOT DE CHENILLE	D3.30		1	2-M5
BATTERIES	F3.01	1	1	2-S5	CHEMISE DE CYLINDRE	A1.01	1	1	1-H4
BIELLES	A1.05	1	1/2	1-H16/1-H17	CHEMISE DE CYLINDRE	A1.01/ A	1	1	1-H6
BIELLES	A1.05/ A	1	1	1-H17	CHENILLE	D3.40/ A		1/1	2-N7 /2-N8
BLOC-CYLINDRES	A1.01	1	1	1-H4	CHENILLE	D3.40/ 1		1	2-N9
BLOC-CYLINDRES	A1.01/ A	1	1	1-H6	COFFRET A OUTILS	L3.10	4	1	3-L17
BORBOTIN MOTEUR	D3.33		1	2-M3	COLLECTEUR D'ADMISSION	A2.54	1	1/2	1-015/1-014
BOITE DE VITESSES	B2.00		1/1/2	1-P14/1-P15/1-P16	COLLECTEUR D'ECHAPPEMENT	A2.54	1	1/2	1-015/1-014
BRAS DE LEVAGE DE LAME DOZER	E3.10		1	2-P10	COMMANDE D'HORC-TACHYMETRE	A1.08		1	1-110
BRAS DE LEVAGE DE LAME DOZER	E3.10/ 1		1	2-P11	COMMANDE D'HORC-TACHYMETRE	A1.08/ A		1/2	1-19 /1-18
BRAS DE LEVAGE DE LAME DOZER	E3.10/ 2		1	2-P12	COMMANDE DE DISTRIBUTION	A1.06		1	1-116
BRAS DE LEVAGE DE LAME DOZER	E3.10/ 3		1	2-P13	COMMANDE DE DISTRIBUTION	A1.06/ A		1	1-115
BRAS DE LEVAGE DE LAME DOZER	E3.10/ 4		1	2-P14	COMMANDE DE FREINS A MAIN	C1.35		1	2-L6
BRAS DE LEVAGE DE LAME DOZER	E3.10/ 5		1	2-P15	COMMANDE DE FREINS A MAIN	C1.35/ A		1	2-L7
BRAS DE LEVAGE DE LAME DOZER	E3.10. 5		1/1	2-P16/2-P17	COMMANDE DE L'OUTIL	E3.25		1/1	2-R3 /2-R4
BRAS DE LEVAGE DES OUTILS	E3.10		1	2-P10	COMMANDE DE POMPE D'INJECTION	A1.16		1	1-15
BUSE D'AIR DE RADIATEUR	A4.01	2	1	1-O4	COMMANDE DE POMPE D'INJECTION	A1.16/ A		1	1-14
CABINE	L1.03	1	1	3-19	COMMANDE DE PRISE DE FORCE	E2.15		1	2-N11
CABINE	L1.04		1/2/1	3-18 /3-17 /3-16	COMMANDE DE VENTILATEUR	A4.09	1	1/2	1-P11/1-P12
			1/2/1	1-15 /3-14 /3-13	COMMANDE HYDRAULIQUE DE .. EMBRAYAGES DE DIRECTION	D2.23		1/2/3	2-L15/2-L16/2-L17

DESIGNATION	SGR.	TAV.	PAG.	GRID	DESIGNATION	SGR.	TAV.	PAG.	GRID
COMMANDE HYDRAULIQUE DES EMBRAYAGES DE DIRECTION	D2.23	1/ 2/ 1		2-M17/2-M16/2-M15	ECLAIRAGE	F4.01		1/ 2	2-T12/2-T13
		2		2-M14	ECLAIRAGE	F4.01/ A		1/ 1	2-T14/2-T15
COMMANDES D'ACCELERATEUR	A2.21	1/ 2/ 1		1-L3 1-L4 1-L5	ECLAIRAGE	F4.01/ 1		1	2-T16
		2/ 1		1-L6 1-L7	ECLAIRAGE	F4.01/ 2		1	3-H2
COMMANDES DIVERSES	A1.15	1		1-7	ECLAIRAGE	F4.01/ 2A		1/ 2	3-H3 3-H4
COMMANDES DIVERSES	A1.15/ A	1		1-16	EMBRAYAGES DE DIRECTION	D2.20		1/ 1	2-L11/2-L12
COMMANDES EXTERIEURES DE BOITE DE VITESSES	B2.07	1		2-H12	ENGRENAGES DE REDUCTEURS LATERAUX AR	B4.12		1	2-I2
COMMANDES INTERNES DE BOITE DE VITESSES	B2.10	1/ 1/ 2		2-H13/2-H14/2-H15	ENGRENAGES DE REDUCTION CENTRALE	B4.04		1/ 2	2-I10/2-I9
CORRECTEUR D'AVANCE	A2.24	1	1	1-L15	ENGRENAGES DE REDUCTION CENTRALE	B4.04/ A		1/ 2	2-I8 2-I7
COURROIES DE VENTILATEUR	A4.09	1	1/ 2	1-P1 1/1-P12	EQUIPMENT ALLEMAGNE	M1.02		1	3-M6
COUSSINETS DE VILEBREQUIN	A1.03	1	1	1-H13	FILTRE A AIR DE MOTEUR	A2.22		1/ 2	1-L8 1-L9
COUSSINETS DE VILEBREQUIN	A1.03/ A	1		1-H14	FILTRE A HUILE DE GRAISSAGE DU MOTEUR	A3.01	1	1	1-O12
COUVERCLE AVANT DE BLOC-CYLINDRES	A1.02	2	1	1-H11	FILTRES A COMBUSTIBLE	A2.24	3	1/ 2	1-L17/1-M17
COUVERCLE DE CULBUTEURS	A1.01	2	1	1-H5	FILTRES A COMBUSTIBLE	A2.24/ A	3	1	1-M13
COUVERCLE DE CULBUTEURS	A1.01/ A	2	1/ 2	1-H7 1-H8	GALET DE RETOUR DE CHENILLE	D3.38		1	2-N5
COUVERCLES DE TRANSMISSION ARRIERE	B4.08	1	1/ 2	2-I6 2-I5	GALET PORTEUR DE CHENILLE	D3.37		1	2-N4
CULASSE	A1.01	2	1	1-H5	GRAISSAGE DE B.V.	B2.06		1/ 2/ 1	2-H9 2-H10/2-H11
CULASSE	A1.01/ A	2	1/ 2	1-H7 1-H8	GRAISSAGE DES EMBRAYAGES DE DIRECTION	D2.24		1	2-M13
CULBUTEURS DE SOUPAPES	A1.07	1	1/ 2	1-H14/1-H13	GRAISSAGE DU MOTEUR	A3.01		1/ 1/ 1	1-O12/1-O11/1-O10
CULBUTEURS DE SOUPAPES	A1.07/ A	1	1/ 2	1-H12/1-H11				1/ 1	1-O9 1-O8
DAMPER DE VILEBREQUIN	A1.04	1		1-H15	GROUPE GENERATEUR DE COURANT	F3.01		1/ 1/ 1	2-S5 2-S4 2-S3
DEMARREUR	F2.01	1	1	2-S9	INJECTEUR	A2.24	4	1	1-M16
DENTS DE SCARIFICATEUR	E3.15	1		2-R2	INJECTEUR	A2.24/ A	4	1	1-M12
DEVIATEUR	E3.02/ 1	1		2-O12	JAUGE D'HUILE DE BOITE DE VITESSES	B2.06	2	1	2-H11
DIAGNOSTIC CENTRALISE	B5.01	1		2-L2	JAUGE D'HUILE MOTEUR	A3.01	1	1	1-O12
DISPOSITIF DE BLOCAGE DE BOITE DE VITESSES	B2.38	1		2-H13	LAME DOZER	E3.13/ 1		1	2-Q9
DISTRIBUTEUR D'EMBRAYAGES DE DIRECTION	D2.23	1	1/ 2/ 3	2-L15/2-L16/2-L17	LAME DOZER	E3.13/ 2		1	2-Q8
DISTRIBUTEUR PRINCIPAL	E3.02	1	1	2-N13	LAMPE DE TABLEAU DE BORD	F4.01/ A	1	1	2-T14
ECHANGEUR DE TEMPERATURE D'HUILE DE GRAISSAGE DU MOTEUR	A2.01	2	1	1-O10	LANCEMENT DU MOTEUR	F2.01		1	2-S9
ECHANGEUR DE TEMPERATURE DU CONVERTISSEUR	B2.18	1		2-H16	LEVIER D'EMBRAYAGES DE DIRECTION	D2.22		1	2-L13
ECLAIRAGE	F4.01	1/ 2/ 1		2-T6 2-T7 2-T8	MAILLONS	D3.40		1	2-N6
		2/ 3/ 1		2-T9 2-T10/2-T11	MAILLONS	D3.40/ A		1	2-N7

DENOMINAZIONI AGGIUNTIVE - DESIGNATIONS SUPPLEMENTAIRES
ZUSAETZLICHE BEZEICHNUNGEN - DENOMINACIONES ADICIONALES

ANTERIORE
COMPLETO
CORRIGE
DA SALDARE
DESTRO
ELIMINATO
ERRATA
ESTERNO
IN ALTERNATIVA
INFERIORE
INTERNO
LATERALE
POSTERIORE
SEMILAVORATO
SINISTRO
SPESSORE
SUPERIORE
VEDERE SGR.

AVANT
COMPLET
CORRIGEZ
A SOUDER
DROIT
ELIMINE'
ERRATA
EXTERIEUR
EN ALTERNATIVE
INFERIEUR
INTERIEUR
LATERAL
ARRIERE
MI-OUVRE'
GAUCHE
EPAISSEUR
SUPERIEUR
VOIR SGR.

VORN
KOMPLETT
RICHTIG
ANZUSCHWEISSEN
RECHTS
ENTFALLEN
FALSCH
AUSSEN
ALS ALTERNATIVE
UNTEN
INNEN
SEITLICH
HINTEN
HALBZEUG
LINKS
DICKE
OBEN
SIEHE UTGR.

ANTERIOR
COMPLETO
LEASE
SOLDAR
DERECHO
ELIMINADO
DONDE DICE
EXTERIOR
ALTERNATIVO
INFERIOR
INTERIOR
LATERAL
POSTERIOR
SEMIELABORADO
IZQUIERDO
GRUESO
SUPERIOR
VEASE SGR.

ADDITIONAL DESCRIPTIONS - DESIGNATIONS SUPPLEMENTAIRES
ZUSÄTZLICHE BEZEICHNUNGEN - DENOMINACIONES ADICIONALES

ASSEMBLY
CORRECT
DELATED
FRONT
IN ALTERNATIVE
INNER
LEFT
LOWER
OUTER
REAR
RIGHT
SEE SGR.
SEMIFINISHED
SIDE
THICKNESS
TO BE WELDED
UPPER
WRONG

COMPLET
CORRIGEZ
ELIMINE'
AVANT
EN ALTERNATIVE
INTERIEUR
GAUCHE
INFERIEUR
EXTERIEUR
ARRIERE
DROIT
VOIR SGR.
MI-OUVRE'
LATERAL
EPAISSEUF
A SOUDER
SUPERIEUR
ERRATA

KOMPLETT
RICHTIG
ENTFALLEN
VORN
ALS ALTERNATIVE
INNEN
LINKS
UNTEN
AUSSEN
HINTEN
RECHTS
SIEHE SGR.
HALBZEUG
SEITLICH
DICKE
ANZUCHWEISSEN
OBEN
FALSCH

COMPLETO
LEASE
ELIMINADO
ANTERIOR
ALTERNATIVO
INTERIOR
IZQUIERDO
INFERIOR
EXTERIOR
POSTERIOR
DERECHO
VEASE SGR.
SEMIELABORADO
LATERAL
GRUESO
SOLDAR
SUPERIOR
DONDE DICE

II

A 19

HINWEISE ZUM GEBRAUCH DES KATALOGS

Beim Aufsuchen der benötigten Ersatzteile ist wie folgt zu verfahren:

- In der Liste der Ausführungen, Seite 4, nachschlagen, um die evtl. Kodenummer der betreffenden Ausführung zu finden; s. Abschnitt 1, Punkt (6).
- In den Bildtafeln, den zugehörigen Ersatzteillisten und in der Änderungstabelle nachschlagen, wie im Abschnitt 1, 2 und 3 angegeben.
- Bei Typen mit Varianten, in der Liste der Varianten, Seite 5, nachschlagen, wo auch die entsprechende fortlaufende Kodenummer und das Verzeichnis der betreffenden Untergruppen zu finden sind.

1. Bildtafeln (s. Beispiel auf Seite 2/7)

Darin sind die für jede Untergruppe der Maschine vorgesehenen Ersatzteile abgebildet. Jedes Ersatzteil ist mit einer **Bezugsnummer (ITEM)** gekennzeichnet, evtl. mit zusätzlichen Angaben. An Stelle der Bezugsnummer kann eine andere Angabe vorhanden sein, z.B.:

E3.06: das Teil ist nur in Utgr. **E3.06** abgebildet.

In jeder Bildtafel ist ausserdem folgendes angegeben:

Kode der Untergruppe (1) — Blattnummer (2), was die Untergruppe mehrere Bildtafeln umfasst — **Änderungsindex (3)**, z.B.: Der der Druckschrift-Nr. 604.01.046, angehängte Index 06, bedeutet, dass die Untergruppe mit dem 6. Nachtrag zum Katalog vom 23. Februar 1985 geändert wurde. Ist kein Index (3) vorhanden, bedeutet dies, dass keine Änderung eingeführt wurde. **Angabe des evtl. Nachtrags (4) — Bezeichnung der Untergruppe (5) — Ausführungskode (6)** entsprechend obigem Punkt (a).

Ist kein Unterscheidungskode angeführt, dann gilt die jeweilige Bildtafel für alle Ausführungen des Typs, auf den sich der Katalog bezieht — **Hinweis auf die Verfügbarkeit von Ersatzteilsätzen (7)**, mit zugehörigen Bezugsnummern (Zusammensetzung dieser Sätze s. Seite 9).

(8) **Gültigkeit** (ausser der Gültigkeit für die Version nach Kode 6):

C 935 → tel. n. 076204 bedeutet, dass die Abbildung, infolge der Änderung 935, bis zur Maschine mit Rahmen-Nr. 076204 gilt.

D 935 tel. 076205 → bedeutet, dass die Abbildung, infolge der Änderung 935, ab der Maschine mit Rahmen-Nr. 076205 gilt.

Weitere Angaben über die Änderungen siehe Änderungstabelle unter Beachtung des nachfolgenden Punkts 3.

2. Ersatzteillisten (s. Beispiel auf Seite 2/7)

Sie umfassen die in den betreffenden Bildtafeln abgebildeten Ersatzteile einer jeden Untergruppe; für jedes Teil ist folgendes angegeben:

(9) **ITEM: Bild-Nr.**, auf die sich die jeweilige «part number» bezieht.

(10) **PART NUMBER. Bestellnummer des Ersatzteils.**

(11) **Q.TY: Gesamtstückzahl** mit Bezug auf die Bildtafel. An Stelle der Stückzahl kann eine folgender Angaben vorhanden sein:

L: nach Länge geliefert, **K**: Satz, in der jeweils gewünschten Menge zu bestellen.

(12) **TRANS. CODE: Kode der Übersetzung der Teilsbezeichnung in französischer, deutscher, spanischer Sprache** (vgl. Verzeichnis der Grundbezeichnungen am Ende des Katalogs, oder Heft 60401105).

(13) **DESCRIPTION/DENOMINAZIONE: Bezeichnung in englischer und italienischer Sprache.**

Bei Einführung von Änderungen wird die Bezeichnung mit Angaben nachfolgender Art ergänzt:

(14) **4606783**

C 951 = Teil vor Änderung Nr. 951

(15) **79021573**

D 951 = Teil nach Änderung Nr. 951

Hinweise auf die Einführung und etwaige Ersatzteilverordnungen siehe Änderungstabelle unter Beachtung des nachfolgenden Punkts 3.

Weitere nützliche Angaben (16) können in der Spalte **DESCRIPTION, DENOMINAZIONE** nach dem Zeichen — eingetragen werden (Übersetzung dieser Angaben aus dem Englischen bzw. Italienischen in französische, deutsche und spanische Sprache s. Verzeichnis der zusätzlichen Angaben vor dem Verzeichnis der Grundbezeichnungen am Ende des Katalogs oder am Anfang des Heftes 60401105). Die Angaben **RIGHT/RECHTS** und **LEFT/LINKS** beziehen sich stets auf die normale Fahrtrichtung der Maschine.

Erscheint neben einer Bezeichnung das Wort **WRONG/FALSCH** ohne eine nachfolgende Zeile mit **CORRECT/RICHTIG**, bedeutet dies, dass das Teil irrtümlich erwähnt worden war.

(17) Untergruppe, Bildtafelnr. (falls die Untergruppe mehrere Bildtafeln umfasst). Seitennr. (falls die Ersatzteilliste für eine Bildtafel mehrere Seiten umfasst)

(18) Kodenummer der Variante, die aufgezeichneten und mit (') gekennzeichneten Teile gehören zu einer bestimmten Variante. Wenn dagegen die Kodenummer nur auf der Bildtafel angegeben ist, so bedeutet dies, dass alle Teile der Untergruppe zu der angegebenen Variante gehören (s. obigen Punkt c)

(19) Abmessungen von Normteilen.

3. Tabellen «ÄNDERUNGEN» (s. Blätter M am Ende des Katalogs)

In diesen Tabellen sind sämtliche während der Maschinenfertigung vorgenommene Änderungen unter Angabe ihrer Einführung und etwaiger Ersatzteilverordnungen aufgeführt.

Angaben und Abkürzungen

C 851 → tel. n. 004652 = Teile vor der Änderung 851, in die Maschinen bis Rahmen-Nr. 004652 eingebaut.

D 851 tel. n. 004653 → = Teile nach der Änderung 851, in die Maschinen ab Rahmen-Nr. 004653 eingebaut.

In den Spalten «Betreffende Sgr. und Ersatzteihinweise» sind die von der jeweiligen Änderung betroffenen Untergruppen sowie etwaige Ersatzteihinweise aufgeführt.

Beispiel eines Ersatzteihinweises:

4606783 = 79021573: nach Aufbrauch der Lagerbestände des Teils 4606783 ist das Teil 79021573 einzubauen.

4606787 = 79021574 + 79021576: nach Aufbrauch der Lagerbestände des Teils 4606787 ist das Teil 79021574 plus Teil 79021576 einzubauen.

4606792 = 79021576 - 4606794: nach Aufbrauch der Lagerbestände des Teils 4606792 ist das Teil 79021576 einzubauen, wobei das Teil 4606794 entfällt.

Ist kein Ersatzteihinweis aufgeführt, dann bedeutet dies, dass das alte Teil weiter zu liefern ist, da es mit dem neuen Teil nicht austauschbar ist.

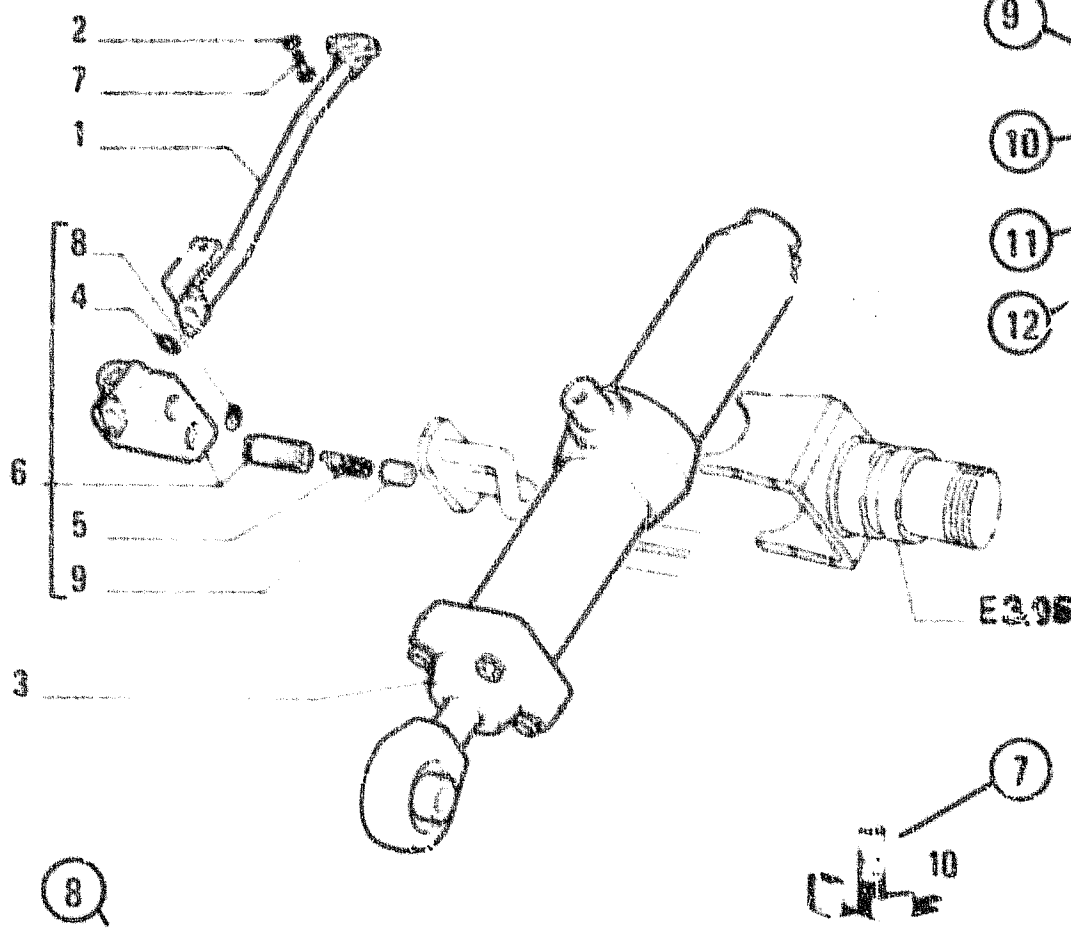

ITEM	PART NUMBER	QTY	TRANS CODE	DESCRIPTION	DESCRIZIONE		
9	4310505	1	133T	PIPE - RIGHT	TUBO - DESTRO		
10	4513436	1	193T	PIPE - RIGHT (*)	TUBO - DESTRO (*)		
	4606773	1	193T	PIPE - LEFT	TUBO - SINISTRO		
			C 951		C 951		
11	79021573	1	193T	PIPE - LEFT	TUBO - SINISTRO		
			D 951		D 951		
12	2	12938001	2	1319 WASHER 10x18	ROSETTA 10x18		
	3	4606785	1	164C CYLINDER - RIGHT ASSEMBLY SEE SCR E3 32	CILINDRO - DESTRO COMPLETO VEDERE SCR E3 32		
		4606787	1	164C CYLINDER - LEFT ASSEMBLY SEE SCR E3 32	CILINDRO - SINISTRO COMPLETO VEDERE SCR E3 32		
				C 951	C 951		
				79021174	1	164C CYLINDER - LEFT ASSEMBLY D 951	CILINDRO - SINISTRO COMPLETO D 951
	4	4606783	1	55A SEAL - WRONG	ANELLO DI TENUTA - ERRATA		
		4606789	1	55A SEAL - CORRECT	ANELLO DI TENUTA - CORRETTO		
	5	4606780	1	100M SPRING	MOLLA		
	6	4606791	1	10V VALVE - RIGHT ASSEMBLY	VALVOLA - DESTRO COMPLETO		
		4606792	1	10V VALVE - LEFT ASSEMBLY	VALVOLA - SINISTRO COMPLETO		
				C 951	C 951		
				79021576	1	10V VALVE - LEFT ASSEMBLY D 951	VALVOLA - SINISTRO COMPLETO D 951
	7	11307021	2	40V SCREW 13x1.25x40	VITE 10x1.25x40		
	8	14453781	1	55A SEAL 1.78x15.60	ANELLO DI TENUTA 1.78x15.60		
	9	4606705	1	50T PLUG	TAPPO		
	10	79021577	K	1K KIT SEE PAGE 9	CORREDO VEDERE PAGINA 9		
			(*)	46SP FOR OPTIONAL 30.1070.05.1	PER VARIANTE 30.1070.05.1		

HYDRAULIC SYSTEM - IMPIANTO IDRAULICO - SYSTEME HYDRAULIQUE - HYDRAULIKANLAGE - E3.02 1

SISTEMA HIDRAULICO

01 02 6 5 1 2 4 3

N.T.R. 63 - 23/2/1985

604.01.046.06

REGLES POUR LA CONSULTATION DU CATALOGUE

En vue d'une recherche correcte des pièces de rechange, il est nécessaire de:

- Consulter la liste des versions à page 4, pour repérer le code numérique éventuel de la version concernée; voir paragraphe 1, point (6) ci-après.
- Consulter les planches illustrées, leurs listes de pièces de rechange et le tableau des modifications comme indiqué aux paragraphes 1, 2 et 3.
- Pour les modèles comportant des variantes, consulter la liste des variantes à page 5, où il est reporté le numéro code correspondant, par ordre progressif, et la liste des sous-groupes concernés.

1. Illustrations (voir exemple page 2/5)

Elles représentent les pièces de rechange de chaque groupe dans lesquels la machine est divisée.

Les pièces de rechange représentées sont repérées par le numéro de référence (ITEM). Le numéro de référence peut être remplacé par d'autres indications, par exemple:

E3.06: pièce illustrée exclusivement au Sgr. **E3.06**.

Chaque illustration reporte en outre:

Code de sous-groupe (1) — **numéro de feuille (2)**, utilisé lorsque ce même sous-groupe comporte plusieurs planches — **indications de mise à jour (3)**, par exemple:

Le suffixe **06**, ajouté au numéro d'imprimé **604.01.016**, indique que le sous-groupe a été modifié avec la 6^{ème} mise à jour du catalogue, prise en date 23 février 1965. Le manque de l'indication (3), signifie qu'aucune modification n'a été apportée. Indication de la **perution d'une mise à jour éventuelle (4)**; — **désignation du sous-groupe (5)** — **code de la version (6)**, avec référence au point (a) précédent. L'absence de codes veut dire que la planche est valable pour toutes les versions du modèle auquel se rapporte le catalogue — **indication de l'existence de kits de rechange (7)**, avec les numéros de référence correspondants (pour la composition des trousseaux voir page 9).

(8) **Validité** (en plus de la validité pour la version, faisant l'objet du code 6): **C 935** — tel. n° **076204** veut dire que l'illustration est valable jusqu'à la machine avec châssis n° **076204**, à la suite de la modification **935**.

D 935 tel. **076205** → veut dire que l'illustration est valable à partir de la modification, avec châssis n° **076205**, à la suite de la modification n° **935**.

Pour des renseignements ultérieurs sur la modification voir le tableau des modifications cité au para. 3 suivant.

2. Listes des pièces de rechange (voir exemple page 2/5)

Ces listes énumèrent les pièces de rechange de chaque groupe, contenues dans les illustrations correspondantes, et elles reportent pour chaque pièce:

(9) **ITEM**: numéro d'appariage de la pièce représentée avec son "part number"

(10) **PART NUMBER**: numéro de commande de la pièce de rechange

(11) **Q.TY**: quantité totale de la pièce, rapportée à la planche. La quantité peut être remplacée par les indications suivantes:

L: livré par longueur, **K**: kit à demander dans les quantités désirées.

(12) **TRANS. CODE**: code pour la recherche de la traduction en français, allemand, espagnol de la description (consulter la liste des désignations base au fond du catalogue, ou la brochure 604.01.105).

(13) **DESCRIPTION/DENOMINAZIONE**: description de la pièce en anglais et en italien.

En cas de modification, la désignation est complétée par une indication du type suivant:

(14) **4606783**

C 951 = pièce antérieure à la modification n° **951**

(15) **79021573**

D 951 = pièce postérieure à la modification n° **951**

Pour l'indication de l'effectuation et les consignes de rechange éventuelles, voir le tableau des modifications cité au para. 3 ci-après.

D'autres indications utiles (16) peuvent figurer dans la colonne **DESCRIPTION/DENOMINAZIONE**, après le signe — (pour la traduction de ces termes de l'anglais ou de l'italien en français, allemand et espagnol voir la liste des désignations supplémentaires au début de la liste des désignations de base, au fond du catalogue ou au début de la brochure 604.01.105. Les termes **RIGHT DROIT** et **LEFT GAUCHE** se rapportent à la direction de roulement avant du tracteur. Si le terme **WRONG ERRATA** figure à côté de la désignation sans le terme correspondant **CORRECT CORRIGEZ** à la ligne suivante, cela veut dire que cette pièce avait été incluse par erreur.

(17) **Sous-groupe, numéro de planche** (si le sous-groupe comporte plusieurs illustrations), **numéro de page** (si la liste des pièces de rechange d'une illustration occupe plus d'une page).

(18) **Numéro-code de la variante**: marque que les pièces énumérées et repérées par (*) concernent la variante indiquée; si par contre le code ne figure que dans l'illustration, cela signifie que toutes les pièces du sous-groupe appartiennent à la variante indiquée (voir point c précédent).

(19) **Dimensions des pièces normalisées**

3. Tableaux "MODIFICATIONS" (reportés sur les feuilles M à la fin du catalogue)

Énumération de toutes les modifications apportées aux machines à la fabrication, leurs effectuations et les consignes éventuelles pour les rechanges.

Indications et abréviations:

C 851 → tel. n° **004652** = pièces antérieures à la modification n° **851**, montées sur des machines avec n° de châssis jusqu'à **004652**.

D 851 tel. n° **004653** → = pièces postérieures à la modification n° **851**, montées sur des machines avec n° de châssis à partir de **004653**.

Aux colonnes "Sgr. concernés et consignes de rechange" sont énumérés les sous-groupes concernés par les différentes modifications et les consignes de rechange éventuelles. Exemple de consignes de rechange:

4606783 = **79021573**: dès l'épuisement des stocks de la pièce **4606783**, monter la pièce **79021573**.

4606787 = **79021574** + **79021576**: dès l'épuisement des stocks de la pièce **4606787**, monter la pièce **79021574** plus la pièce **79021576**;

4606792 = **79021576** - **4606794**: dès l'épuisement des stocks de la pièce **4606792**, monter la pièce **79021576** en éliminant la pièce **4606794**.

Si aucune consigne de rechange n'est reportée, cela veut dire que la pièce de l'ancien montage doit être toujours livrée de rechange, n'étant pas interchangeable avec celle du nouveau montage.

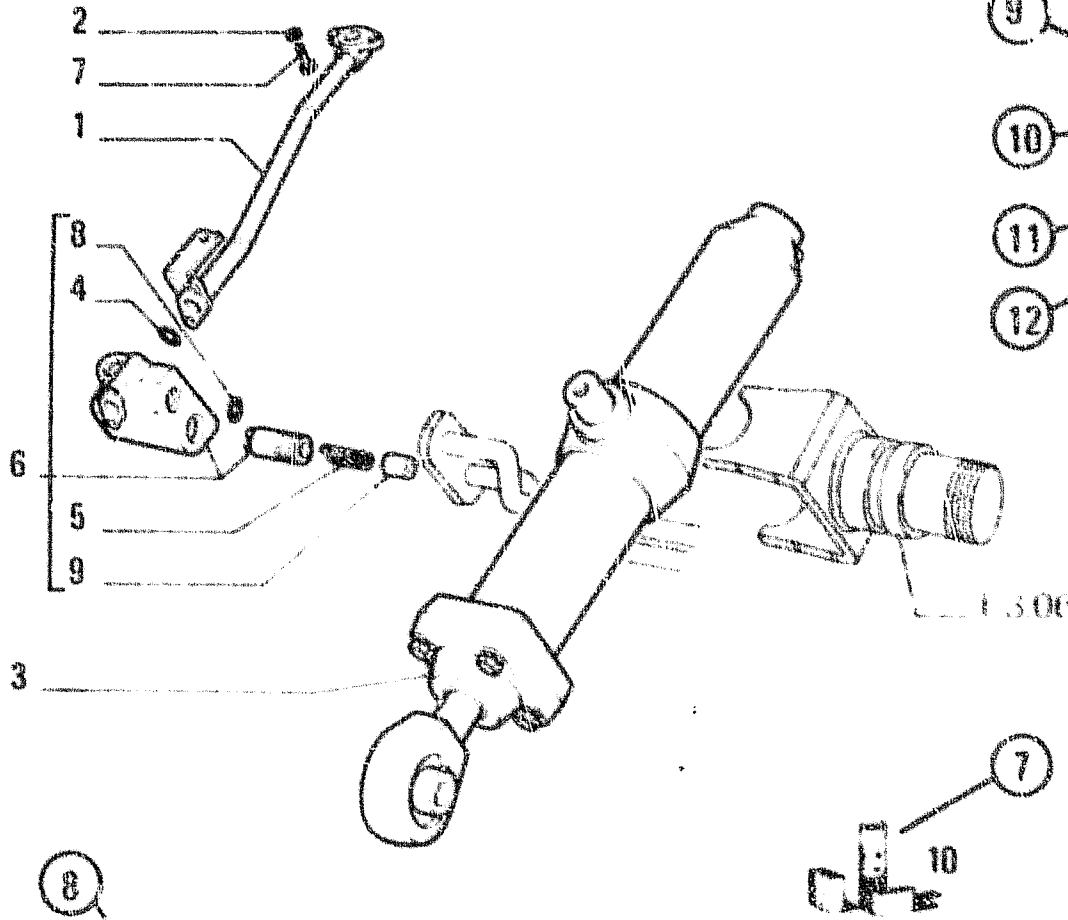

8 C 935 → tel.n. 076204

Optional Variante 30 1070.06 1

ITEM	PART NUMBER	QTY	TRANS CODE	DESCRIPTION	DESCRIZIONE
9	4118955	1	193T	PIPE - RIGHT	TUBO - DESTRO
10	4113486	1	1937	PIPE - RIGHT (*)	TUBO - DESTRO (*)
	4026783	1	1937	PIPE - LEFT	TUBO - SINISTRO
				C 951	C 951
11	79021573	1	193T	PIPE - LEFT	TUBO - SINISTRO
12				D 951	D 951
				C 951	C 951
2	12530601	2	131R	WASHER 10x18	ROSETTA 10x18
3	4606785	1	164C	CYLINDER - RIGHT ASSEMBLY SEE SGR E3 32	CILINDRO - DESTRO COMPLETO VEDERE SGR E3 32
	4606787	1	164C	CYLINDER - LEFT ASSEMBLY SEE SGR E3 32	CILINDRO - SINISTRO COMPLETO VEDERE SGR E3 32
				C 951	C 951
	79021574	1	164C	CYLINDER - LEFT ASSEMBLY	CILINDRO - SINISTRO COMPLETO
				D 951	D 951
4	4606788	1	55A	SEAL - WRONG	ANELLO DI TENUTA - ERRATO
	4606789	1	55A	SEAL - CORRECT	ANELLO DI TENUTA - CORRETTO
5	4606790	1	100M	SPRING	MOLLA
6	4606791	1	10V	VALVE - RIGHT ASSEMBLY	VALVOLA - DESTRO COMPLETO
	4606792	1	10V	VALVE - LEFT ASSEMBLY	VALVOLA - SINISTRO COMPLETO
				C 951	C 951
	79021576	1	10V	VALVE - LEFT ASSEMBLY	VALVOLA - SINISTRO COMPLETO
				D 951	D 951
7	11307021	2	40V	SCREW 10x1.25x40	VITE 10x1.25x40
8	14133391	1	55A	SEAL 1.78x15.00	ANELLO DI TENUTA 1.78x15.00
9	4606795	1	50T	PLUG	TAPPO
10	79021577	K	1R	KIT SEE PAGE 9	CORREDO VEDERE PAGINA 9
(*)				485P FOR OPTIONAL 30 1070.06 1	PER VARIANTE 30 1070.06 1

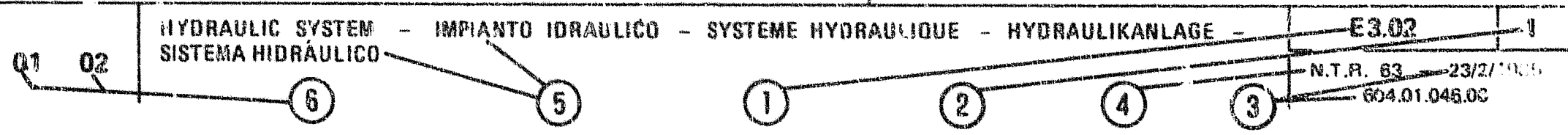

AVVERTENZE PER LA CONSULTAZIONE DEL CATALOGO

Per una corretta ricerca delle parti di ricambio, è necessario:

- Consultare l'elenco delle versioni a pag. 4, per individuare l'eventuale codice numerico della versione che interessa, vedere seguente paragrafo 1, punto (N).
- Consultare le illustrazioni, i relativi elenchi delle parti di ricambio e la tabella modifiche come indicato ai paragrafi 1, 2 e 3.
- Per i modelli comprendenti varianti, consultare l'elenco varianti a pag. 5, dove viene riportato anche il numero di codice corrispondente, per ordine progressivo e l'elenco dei sottogruppi interessati.

1. Illustrazioni (vedere esempio a pag. 2/3)

Mostrano le parti di ricambio di ciascun sottogruppo in cui è divisa la macchina. Le parti di ricambio illustrate sono contraddistinte dal numero di riferimento (ITEM). Il numero di riferimento può essere sostituito da altre indicazioni; ad esempio:

E3.05: parte illustrata unicamente nel Sgr. **E3.05**

Ogni illustrazione riporta inoltre:

Codice del sottogruppo (1) — numero di foglio (2), utilizzato quando il medesimo sottogruppo comprende più tavole — indicazione di aggiornamento (3), esempio:

Il suffisso **06**, aggiunto al numero di stampato **604.01.046**, indica che il sottogruppo è stato modificato, con il 6° aggiornamento del catalogo, diramato in data **23 febbraio 1985**. La mancanza dell'indicazione (3), significa che non vi sono state modifiche.

Indicazione dell'eventuale pubblicazione di aggiornamento (4); — **denominazione del sottogruppo (5)** — **codice della versione (6)**, con riferimento al precedente punto (1). In mancanza di codice, si intende che la tavola è valida per tutte le versioni del modello cui si riferisce il catalogo — **indicazione dell'esistenza di corredi di ricambio (7)**, con relativi numeri di riferimento (per la composizione dei corredi, vedere pag. 9).

(8) Validità (oltre alla validità per la versione, di cui al codice 6).

C 935 → tel. n. **076204** significa che l'illustrazione vale fino alla macchina telaio n. **076204**, in conseguenza della modifica **935**.

D 935 tel. **076205** → significa che l'illustrazione vale dalla macchina con telaio n. **076205**, in conseguenza alla modifica n. **935**.

Per ulteriori informazioni sulla modifica, vedere la tabella modifiche di cui al successivo punto 3.

2. Elenchi delle parti di ricambio (vedere esempio a pag. 2/3)

Elencano le parti di ricambio di ciascun sottogruppo, contenute nelle illustrazioni corrispondenti, e riportano per ogni parte:

(9) ITEM: numero di abbinamento del particolare illustrato col relativo "part number".

(10) PART NUMBER: numero di ordinazione del particolare di ricambio.

(11) Q.TY: quantità complessiva del particolare, riferita alla tavola. La quantità può essere sostituita dalle seguenti indicazioni:

L: fornito a lunghezza, **K**: corredo (Kit) da ordinarsi nei quantitativi desiderati.

(12) TRANS. CODE: codice per la ricerca della traduzione in francese, tedesco, spagnolo della descrizione (consultare, l'elenco delle denominazioni base in fondo al catalogo, o il fascicolo 604.01.105).

(13) DESCRIPTION/DENOMINAZIONE: descrizione del particolare in inglese e italiano.

In caso di modifica, la denominazione è completata dal seguente tipo di indicazione:

(14) 4606783

C 951 = parte anteriore alla modifica 951

(15) 79021573

D 951 = parte posteriore alla modifica 951.

Per l'indicazione dell'attuazione e le eventuali norme di ricambio, vedere la tabella modifiche di cui al successivo punto 3.

Altre indicazioni utili **(16)** possono venire inserite nella colonna **DESCRIPTION/DENOMINAZIONE**, dopo il segno — (per la traduzione dall'inglese o italiano in Francese, Tedesco e Spagnolo di queste voci, vedere l'elenco delle denominazioni aggiuntive all'inizio dell'elenco denominazioni base, in fondo al catalogo o all'inizio del fascicolo 604.01.105). I termini **RIGHT/DESTRO** e **LEFT/SINISTRO** sono riferiti alla direzione di marcia avanti della macchina. Se di fianco ad una denominazione compare il termine **ERRATA** senza il corrispondente **CORRIGE** sulla riga successiva, ciò significa che il particolare era stato inserito erroneamente.

(17) Sottogruppo, numero di tavola (se il sottogruppo comprende illustrazioni diverse), **numero di pagina** (se per una stessa illustrazione l'elenco delle parti di ricambio occupa più di una pagina).

(18) Numero di codice della variante: indica che le parti elencate e contraddistinte da (*) sono pertinenti a quella data variante, se invece il codice compare solo sull'illustrazione ciò significa che tutte le parti di quel sottogruppo appartengono a quella variante (vedere precedente punto c).

(19) Dimensioni dei particolari normalizzati.

3. Tabelle "MODIFICHE" (riportate sui fogli M al termine del catalogo)

Elencano tutte le modifiche apportate alle macchine durante la produzione, le relative situazioni e le eventuali norme di ricambio.

Indicazioni ed abbreviazioni:

C 851 → tel. n. **004652** = parti anteriori alla modifica 851, montate su macchine con n. di telaio fino al **004652**.

D 851 tel. n. **004653** → = parti posteriori alla modifica 851, montate su macchine con numero di telaio dal **004653**.

Nella colonna "Sgr. interessati e norme di ricambio" vengono elencati i sottogruppi interessati delle varie modifiche e le eventuali norme di ricambio.

Esempio di norme di ricambio:

4606783 = 79021573: ad esaurimento scorte del particolare **4606783**, montare il **79021573**.

4606787 = 79021574 + 79021576: ad esaurimento scorte del particolare **4606787** montare il **79021574** più il **79021576**;

4606792 = 79021576 - 4606794: ad esaurimento scorte del particolare **4606792**, montare il **79021576** eliminando il **4606794**.

Se non vengono riportate norme di ricambio, ciò significa che il particolare premodifica deve sempre venire fornito di ricambio, non essendo intercambiabile con quello post modifica.

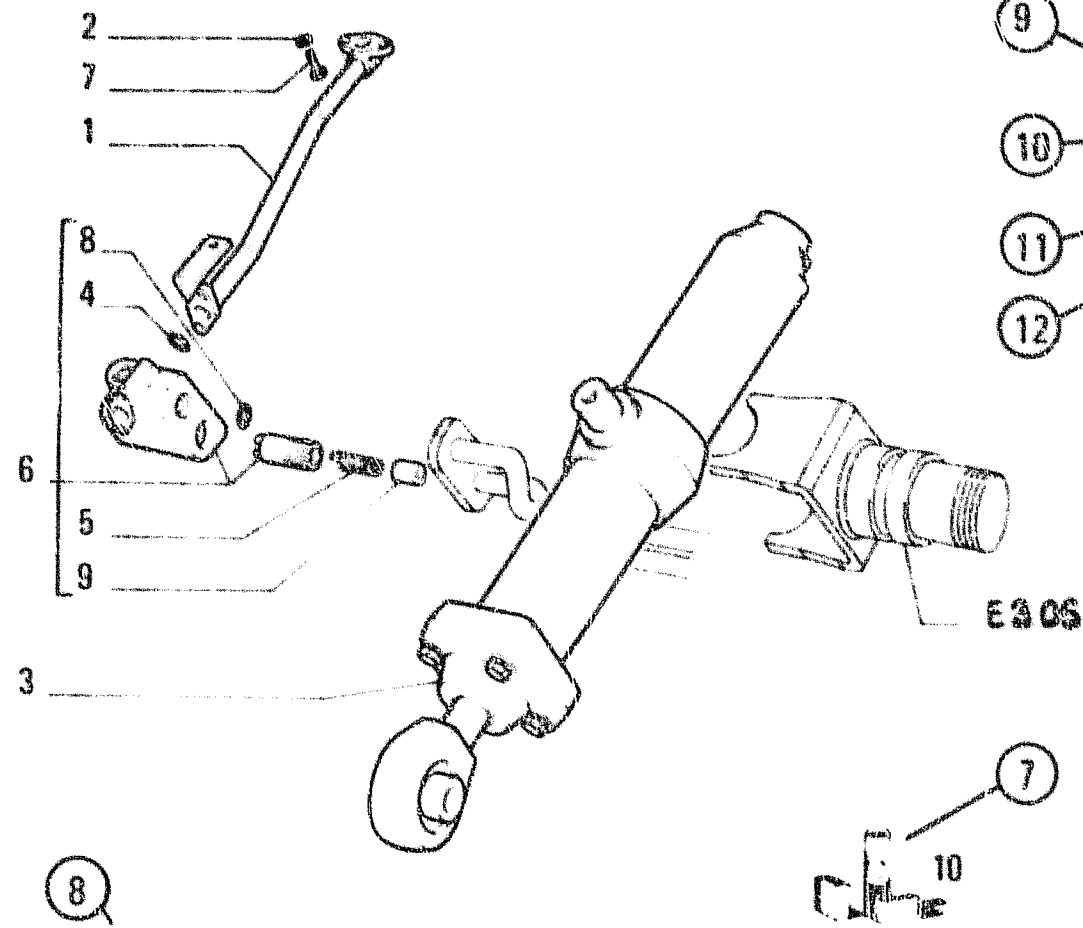

C 935 → tel.n. 076204

Optional Variante 30.1070.06.1

ITEM	PART NUMBER	QTY	TRANS CODE	DI/CAPTION	DESCRIZIONE
9	4318935	1	193T PIPE - RIGHT		TUBO - DESTRO (13)
10	4512436	1	193T PIPE - RIGHT (*)		TUBO - DESTRO (*) (14)
	4606783	1	193T PIPE - LEFT		TUBO - SINISTRO (14)
			C 951		C 951
11	79021573	1	193T PIPE - LEFT		TUBO - SINISTRO (15)
12			D 951		D 951
2	12639601	2	131R WASHER 10x18		RIVETTINA 10x18 (15)
3	4606784	1	164C CYLINDER - RIGHT ASSEMBLY (SEE 9/A E3 32)		CILINDRO - DESTRO COMPLETO VEDERE SER E3 32
	4606787	1	164C CYLINDER - LEFT ASSEMBLY (SEE 7/BR E3 32)		CILINDRO - SINISTRO COMPLETO VEDERE SER E3 32
			C 951		C 951
	79021574	1	164C CYLINDER - LEFT ASSEMBLY D 951		CILINDRO - SINISTRO COMPLETO D 951
4	4606785	1	55A SEAL - WRONG		ANELLO DI TENUTA - ERRATO (16)
	4606789	1	55A SEAL - CORRECT		ANELLO DI TENUTA - CORRETTO (16)
5	4606790	1	100M SPRING		MOLLA (16)
6	4606791	1	10V VALVE - RIGHT ASSEMBLY		VALVOLA - DESTRO COMPLETO (16)
	4606792	1	10V VALVE - LEFT ASSEMBLY		VALVOLA - SINISTRO COMPLETO (16)
			C 951		C 951
	79021576	1	10V VALVE - LEFT ASSEMBLY D 951		VALVOLA - SINISTRO COMPLETO D 951 (19)
7	11307021	2	40V SCREW 10x1.25x40		VITE 10x1.25x40 (19)
8	1445391	1	55A SEAL 1.78x15.00		ANELLO DI TENUTA 1.78x15.00 (19)
9	4606793	1	57F PLUG		TAPPO (19)
10	79021577	K	1R KIT SEE PAGE 9		CORREDO VEDERE PAGINA 9 (18)
			(*)	466P FOR OPTIONAL 32.1670.06.1	PER VARIANTE 30.1070.06.1 (18)

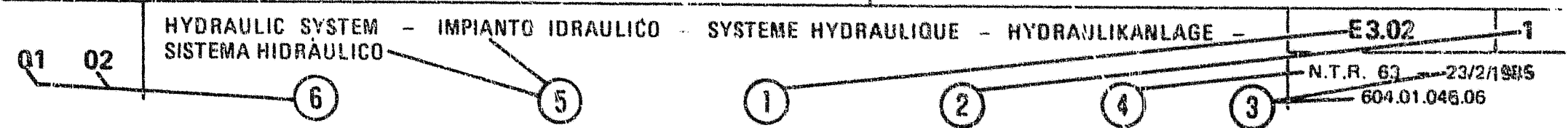

HYDRAULIC SYSTEM - IMPIANTO IDRAULICO - SYSTEME HYDRAULIQUE - HYDRAULIKANLAGE

E3.02 1
N.T.R. 63 - 23/2/1985
604.01.046.06

B6

USE OF THE CATALOG

To locate the parts correctly, proceed as follows:

- Consult the version list on page 4 to find the code number of the version required, see following para 1 (6).
- Consult the illustrations, the associated parts lists and the "Modifications" tables as directed below in 1, 2 and 3.
- To identify the component of the possible special equipment of the machine, consult the optional equipment list on page 5 to find the code number and subgroup

1. Illustrations (see example on page 2/1)

Illustrations show the parts of each subgroup. The parts illustrated are identified by a reference number (ITEM). This number may be replaced by other indications, for example:

E3.06: Part shown only in subgroup E3.06

Moreover, each illustration shows:

— Subgroup number (1) — Sheet number (2) used when one subgroup covers several sheets, and — Updating indication (3), for example

Suffix 06, to print no. 604.01.046, indicates that subgroup modification is shown in 6th updating of the catalog dated 23-2-85. When code (3), is missing, no changes were introduced. Updating publication description, if any (4); subgroup title (5) — version code (6) which reference to previous point (a)

In lack of said code, the illustration applies to all model versions covered by the catalog

— Indication of part kit (7), with associated part numbers and part kit symbol. (See page 9 for kit composition)

— (8) Applicability (besides the version code 6): C 935 → tel. n. 976204 which means that the illustration is valid up to machine S/N 976204, as a consequence of modification 935.

D 935 tel. 076205 → which means that the illustration is valid from machine S/N 076205, as a consequence of modification 935

For further information on the modification, see the "Modifications" tables as per point 3.

2. Part list (see example on page 2/1)

They list the parts of each subgroup contained in the corresponding illustrations. The following is shown for each part:

(9) ITEM: number associating the part shown with the respective "part number"

(10) PART NUMBER: part order number

(11) Q.TY: total quantity of the part. The quantity may be replaced by the following indications:

L = supplied by length, K = kit to be ordered in the desired quantity.

(12) TRANS. CODE for retrieval of the French, German, Spanish translations of the part names (consult the basic part names in last section of Catalog, or form 604 01 105).

(13) DESCRIPTION/DENOMINAZIONE: Description of the part in English and Italian.

In case of modification, the description is completed with this kind of indication

(14) 4606783

(15) 79021573

C 951 which means that the part is valid before the modification 951

D 951 which means that the part is valid after the modification 951

For the effectiveness and the directions for replacement, see the "Modifications" tables as per following point 3.

Other useful indications (16) may be provided under DESCRIPTION/DENOMINAZIONE after sign — (for French, German, Spanish equivalents, see additional list heading the basic part name list, at the end of catalog or at the beginning of booklet 604.01 105. Terms RIGHT/DESTRO and LEFT/SINISTRO refer to the direction of machine forward travel.

Should the word WRONG appear next to a part name without the corresponding CORRECT on the line immediately below it means that the associated part was erroneously included at an earlier stage.

(17) Subgroup, illustration number (when the subgroup includes more than one illustration), page number (when the listing for one illustration takes more than one page)

(18) Optional equipment code: this number indicates that parts listed and marked (*) belong to that given equipment. If on the contrary the code appears on the illustration only, it means that all parts of the subgroup belong to the special equipment in question (See para (c) above)

(19) Standard part dimensional data

3. "MODIFICATIONS" tables (on pages M at the end of the catalog)

They list all modifications introduced on the machines during their production, their effectiveness and the directions for replacement if any. Indications and codes:

C 851 → tel. n. 004652 which means part valid before modification 851, installed on machines with S/N up to 004652

D 851 tel. n. 004653 → which means part valid after modification 851, installed on machines with S/N from 004653.

The last column is reserved to the summary of the involved subgroups and the directions for replacement if any.

Examples of direction for replacement:

4606783 = 79021573: on exhaustion of stocks of part 4606783 fit part 79021573

4606787 = 79021574 + 79021576: on exhaustion of stocks of part 4606787 fit part 79021574 plus 79021576.

4606792 = 79021576 - 3606794: on exhaustion of stocks of part 4606792 fit 79021576 and discard 4606794.

If no directions for replacement are given, this means that the old and new parts are not interchangeable and, hence, the former must be supplied as spare.

FIATALLIS FD7

NTR. 205 30.09.91 - 60401081.06

DENOMINACIONES	SGR.	TAV.	PAG.	GRID	DENOMINACIONES	SGR.	TAV.	PAG.	GRID
TAPAS DE TRANSMISION POSTERIOR	0408	1	1 2	2-16 2-15					
TENSOR DE LA CORREA DEL VENTILADOR	A409	1	1 2	1-P11/1-P12					
TERMOMETRO DEL ACEITE DEL CAMBIO	F5 10		1	3-H9					
TERMOMETRO DEL ACEITE DEL MOTOR	F5 10		1	3-H9					
TERMOSTATO	A4 07	1	1 2	1-02 1-P2					
TESTIGOS DE FUNCIONAMIENTO	F5 10		1	3-H9					
TRONERA DE ENBRASQUE DE LA DIRECCION	02 22	2	1	2-L14					
TIPO ALEMANIA	M1 02		1	3-M5					
TOLNOROPS	L3 05		1	3-L12					
TOZA DE FUERZA	E2 16		1	2-N12					
TUBERIA DE ESCAPE	A2 55		1	1-013					
TUBERIAS DE ADMISION	A2 22		1 2	1-L8 1-L9					
TUBERIAS DE CONDENSABLE	A2 24 A	2	1	1-M14					
TUBERIAS DE VENTILACION DEL MOTOR	A1 25		1	1-3					
TUBERIAS DEL DEPOSITO DE COMBUSTIBLE	A2 01		1 2	1-12 1-L2					
VALVULA	E3 34		1	2-S10					
VALVULA BY-PASS	E3 02 1		1	2-012					
VALVULA DE RESERVA DE LA RUEDA GUIADORA	03 34	1	1 2	2-M2 2-N2					
VALVULAS DE DISTRIBUCION	A1 07	1	1 2	1-114 1-113					
VALVULAS DE DISTRIBUCION	A1 07 A	1	1 2	1-112 1-111					
VARIADOR DE AVANCE	A2 24	1	1	1-L15					
VARILLA DE NIVEL DEL ACEITE	A3 01	1	1	1-012					
VARILLA DE NIVEL DEL ACEITE DEL CAMBIO	B2 05	2	1	2-H11					
VARILLA DEL CAMBIO DE VELOCIDADES	B2 07		1	2-H12					
VENTILADOR	A4 09	1	1 2	1-P11/1-P12					
VENTILADOR Y SU MANDO	A4 09 1	1	1	1-P13					
VOLANTE DEL CIGUENAL	A1 03	1	1	1-H13					
VOLANTE DEL CIGUENAL	1. 03/ A	1	1	1-H14					
ZAPATAS	D3 40	1	1	2-N6					
ZAPATAS	D3 40/ A	1	1	2-N7					
ZAPATAS	D3 40/ 1		1	2-N9					

FIATALLIS FD7

NTR. 205 30.09.91 - 60401081.06

DENOMINACIONES	SGR.	TAV.	PAG.	GRID	DENOMINACIONES	SGR.	TAV.	PAG.	GRID
MANOMETRO DEL ACEITE DEL MOTOR	F5.10	1		3-H9	SISTEMA DE ALUMBRADO	F4.01	2	3	1 2-T9 2-T102-T11
MOTOR	A0.00	1		1-H2					1-2 2-T122-T13
MOTOR DE ARRANQUE	F2.01	1	1	2-S9	SISTEMA DE ALUMBRADO	F4.01 A	1	1	2-T142-T15
ORUGA	D3.40/ A		1/1	7-N7 2-N8	SISTEMA DE ALUMBRADO	F4.01 1	1		2-T16
ORUGA	D3.40/ 1		1	2-N9	SISTEMA DE ALUMBRADO	F4.01 2	1		3-H2
PALANCAS DE EMBRAQUE DE LA DIRECCION	D2.22	1	1	2-L13	SISTEMA DE ALUMBRADO	F4.01 2A	1	2	3-H3 3-H4
PALETA ABRETROCHAS	E3.13/ 1		1	2-Q9	SISTEMA HIDRAULICO	E3.02	1	1	2-N132-N142-N15
PALETA ABRETROCHAS	E3.13/ 2		1	2-Q8					1 1 1 2-N162-N172-O17
PEDALES DE FRENO	C1.01	1	1	2-L3					1 1 1 2-O162-O162-O14
PIÑONES DE LA DISTRIBUCION	A1.08		1	1-H6	SISTEMA HIDRAULICO	E3.02 1	1		2-O13
PIÑONES DE LA DISTRIBUCION	A1.08/ A		1	1-H5	SISTEMA HIDRAULICO	E3.02 2	1		2-O12
PISTON	L3.04	2	1	3-L11	SISTEMA HIDRAULICO	E3.02 3	1		2-O11
PREFILTRO DE AIRE DEL MOTOR	A2.22		1/2	1-L8 1-L9	SISTEMA HIDRAULICO	E3.02 4	1		2-O10
PROTECCIONES DEL ASIENTO	L3.10		1/1 2	3-L133-L143-L15	SISTEMA HIDRAULICO	E3.02 5	1		2-O9
			1/1 1	3-L163-L173-M17	SISTEMA HIDRAULICO	E3.02 6	1		2-O8 2-O7
PROTECCIONES DEL ASIENTO	L3.10/ 1		1/1	3-M163-M15	SISTEMA HIDRAULICO	E3.02 7	1		2-O6
PROYECTOR ANTERIOR	F4.01/ A	2	1	2-T15	SISTEMA HIDRAULICO	E3.02 8	1		2-O5
PROYECTOR ANTERIOR	F4.01/ 1	1	1	2-T16	SISTEMA HIDRAULICO DE EMBRAQUES DE DIRECCION	D2.21	1	2	3 2-L152-L162-L17
PROYECTOR POSTERIOR	F4.01/ 1		1	2-T16					1 2 1 2-M17 2-M162-M15
PROYECTOR POSTERIOR	F4.01/ 1A		1	2-T17					2 2-M14
PULVERIZADOR	A2.24	4	1	1-M16	SOPORTES DE GATOS DEL ABRETROCHAS	E3.05	1		2-P9
PULVERIZADOR	A2.24/ A	4	1	1-M12	SOPORTES DE RUEDA GUIADORA	D3.34	2	1	2-N3
RADIADOR DE AGUA DEL MOTOR	A4.01	1	1/2	1-O8 1-O5	SOPORTES DE UTILES	E3.05	1		2-P9
REGULADOR DE VELOCIDAD	A2.24	1	1	1-L15	SOPORTES VARIOS	L1.30	1		3-L6
RODILLO DE APOYO DE LA ORUGA	D3.37		1	1-N4	SOPORTE S VARIOS	L1.30/ A	1		3-L7
RODILLO DE SOPORTE DE LA ORUGA	D3.38		1	2-N5	SOPORTE S VARIOS	L1.30/ 1	1		3-L8
RUEDA GUIADORA	D3.34	2	1	2-N3	SUSPENSION ANTERIOR	D3.01	1		2-M7
RUEDA MOTRIZ	D3.33		1	2-M3	SUSPENSION POSTERIOR	D3.05	1		2-M6
SEÑALIZACION DE AVISO	F5.01		1	1-H6	TAPA ANTERIOR DEL BLOQUE	A1.02	2	1	1-H11
SEÑALIZACION DE AVISO	F5.01/ 1		1	3-H7	TAPA DE CULATA	A1.01	2	1	1-H5
SEÑALIZACION DE AVISO	F5.01/ 1A		1	3-H8	TAPA DE CULATA	A1.01/ A	2	1/2	1-H7 1-H8
SISTEMA DE ALUMBRADO	F4.01		1/2 1	2-T6 1/2-T7 1/2-T8					

DENOMINACIONES	SGR.	TAV.	PAG.	GRID	DENOMINACIONES	SGR.	TAV.	PAG.	GRID
CAPOT	L1 01		2/3 1	3-H53-H43-H13	ENGRASE DE EMBRAGUES DE DIRECCION	D2 24		1	2-M13
			2/1	3-H23-H11	ENGRASE DEL CAMBIO	B2 06		1 2 1	3-H9 2-H102-H11
CARTER DE ACEITE	A1 02	1	1/2	1-H9 1-H10	ENGRASE DEL MOTOR	A3 01		1 1 1	1-O10 1-O11 1-O10
CIGUEÑAL	A1 03	1	1	1-H13				1 1	1-O9 1-O9
CIGUEÑAL	A1 03/ A	1	1	1-H14	ENLACE DE ARMAZONES DE CADENA	D3 31		1	2-M4
CILINDRO DE RUEDA GUIA ORA	D3 34	1	1/2	2-M2 2-N2	ESLABONES	D3 40	1	1	2-M5
CILINDRO TILT	E3 02 6		1	2-O6	ESLABONES	D3 40 A	1	1	2-M7
CINTA DE FRENO	C1 01	2	1/2	2-L4 2-L5	ESLABONES	D3 40 1		1	2-M9
COJINETES DEL CIGUEÑAL	A1 03	1	1	1-H13	FILTRO DE AIRE DE MOTOR	A2 22		1 2	1-L9 1-L9
COJINETES DEL CIGUEÑAL	A1 03/ A	1	1	1-H14	FILTRO DEL ACEITE DEL MOTOR	A3 01	1	1	1-O12
COLECTOR DE ADMISION	A2 54	1	1/2	1-O15 1-O14	FILTROS DE COMBUSTIBLE	A2 24	3	1 2	1-L17 1-M17
COLECTOR DE ESCAPE	A2 54	1	1 2	1-O15 1-O14	FILTROS DE COMBUSTIBLE	A2 24 A	3	1	1-M13
CORREAS DEL VENTILADOR	A4 09	1	1/2	1-P11 1-P12	FRENO DE MANO	C1 35		1	2-L6
CULATA	A1 01	2	1	1-H5	FRENO DE MANO	C1 35 A		1	2-L7
CULATA	A1 01/ A	2	1 2	1-H7 1-H8	GATO DE ELEVACION	E3 02	5	1	2-O16
DEFLECTOR DEL RADIADOR	A4 01	2	1	1-O4	GATO DE PIVOTAMIENTO DE LA PALETA	E3 02 5	2	1	2-O7
DEPOSITO DE ACEITE	E3 23		1 2	2-R5 2-R5	GATO DEL ESCARIFICADOR	E3 02 2		1	2-O11
DEPOSITO DE COMBUSTIBLE	E2 01		1 2	1-Q2 1-L2	GENERADOR DE CORRIENTE	F3 01		1 1 1	2-S5 2-S4 2-S3
DIAGNOSTICO CENTRAL	E5 01		1	2-L2	GUARDABARRIOS	L3 04	1	1 2	3-L9 3-L10
DIENTES DE ESCARIFICADOR	E3 15		1	2-R2	HERRAMIENTAS	H1 01		1 1	3-H10 3-H11
DISTRIBUIDOR DE EMBRAGUE DE LA DIRECCION	D2 23	1	1 2 3	2-L15 2-L16 2-L17	HERRAMIENTAS	H1 01 1		1 1	3-H12 3-H13
DISTRIBUIDOR PRINCIPAL	E3 07	1	1	2-N13	HERRAMIENTAS	H1 01 2		1	3-H14
EJE DE RUEDA MOTRIZ	D3 33	1	1	2-M3	INYECTOR	A2 24	4	1	1-M16
EMBLEMAS	L1 25		1	3-L7	INYECTOR	A2 24 A	4	1	1-M12
EMBLEMAS	L4 10		1	3-M11	LUZ DEL TABLERO	F4 01 A	1	1	2-T14
EMBOLOS	A1 05	1	1/2	1-H16 1-H17	MANDO DE TOMA DE FUERZA	E2 15		1	2-N11
EMBOLOS	A1 05/ A	1	1	1-H17	MANDO DEL VENTILADOR	A4 09	1	1 2	1-P11 1-P12
EMBRAGUES DE DIRECCION	D2 20		1/1	2-L11 2-L12	MANDOS DEL ACELERADOR	A2 21		1/2 1	1-L3 1-L4 1-L5
ENCLAVAMIENTO DEL CAMBIO	B2 38		1	2-H3				2/1	1-L6 1-L7
ENGRANAJES DE REDUCCION CENTRAL	B4 04		1/2	2-H0 2-I9	MANDOS VARIOS	A1 15		1	1-I7
ENGRANAJES DE REDUCCION CENTRAL	B4 04/ A		1/2	2-I8 2-I7	MANDOS VARIOS	A1 15/ A		1	1-I6
ENGRANAJES DE REDUCTORES LATERALES POSTERIORES	B4 12		1	2-I2	MANOMETRO DEL ACEITE DEL CAMBIO	F5 10		1	3-H9

INDICE ALFABETICO

DENOMINACIONES	SGR.	TAV.	PAG.	GRID	DENOMINACIONES	SGR.	TAV.	PAG.	GRID
ACCESORIOS	H1.04		1/1	3-H15/3-H16	BOMBA DE AGUA	A4.02	2	1 2 3	1-P3 1-P4 1-P5
ACCIONAMIENTO DEL UTIL	E3.25		1/1	2-R3 /2-R4	BOMBA DE ALIMENTACION	A2.24	1	1	1-L15
ALTERNADOR	F3.01	2	1	2-S4	BOMBA DE ALIMENTACION	A2.24 A	3	1	1-M13
ANCLAJES MOTOR	A0.02		1	1-H9	BOMBA DE EMBRAGUE DE LA D.RECCION	D2.23	3	1 2	2-M15/2-M14
ANTIBRAKIO DEL CIGUELA	A1.04		1	1-H15	BOMBA DE INYECCION	A2.24	1	1	1-L15
ARBOL DE LEVAS	A1.07	1	1/2	1-H14/1-H15	BOMBA DE INYECCION	A2.24 A	1	1	1-M13
ARBOL DE LEVAS	A1.07 A	1	1/2	1-H12/1-H11	BOMBA DEL SISTEMA HIDRAULICO	E3.02	2	1 2	2-N14/2-N15
ARBOL DE TRANSMISION DEL CAMBIO AL PUENTE	B3.01		1	2-H2	BRAZOS DE ELEVACION DE UTILES	E3.16		1	2-P10
ARMAZON DE CADENA	D3.30		1	2-M5	BRAZOS DE ELEVACION DEL ABRETROCHAS	E3.10		1	2-P10
ARRANQUE DEL MOTOR	F2.01		1	2-S9	BRAZOS DE ELEVACION DEL ABRETROCHAS	E3.10.1		1	2-P11
ARRASTRE DE LA BOMBA DE INYECCION	A1.16		1	1-H5	BRAZOS DE ELEVACION DEL ABRETROCHAS	E3.10.2		1	2-P12
ARRASTRE DE LA BOMBA DE INYECCION	A1.16 A		1	1-H4	BRAZOS DE ELEVACION DEL ABRETROCHAS	E3.10.3		1	2-P13
ARRASTRE DEL HOROTACOMETRO	A1.08		1	1-H10	BRAZOS DE ELEVACION DEL ABRETROCHAS	E3.10.4		1	2-P14
ARRASTRE DEL HOROTACOMETRO	A1.08 A		1/2	1-H9 /1-H8	BRAZOS DE ELEVACION DEL ABRETROCHAS	E3.10.5		1	2-P15
ASIENTO DEL CONDUCTOR	L6.01		1	3-M10	BRAZOS DE ELEVACION DEL ABRETROCHAS	E3.10.6		1 1	2-P16/2-P17
ASIENTO DEL CONDUCTOR	L6.01.1		1	3-M9	CABINA	L1.03.1		1	3-I9
ASIENTO DEL CONDUCTOR	L6.01.2		1	3-M8	CABINA	L1.04		1 2 1	3-I8 3-I7 3-I6
BALANCONES	A1.07	1	1 2	1-H11/1-H13				1 2 1	3-I5 3-I4 3-I3
BALANCONES	A1.07 A	1	1 2	1-H12/1-H11				1 1 1	3-I2 3-L2 3-L3
BARRA DE ARRASTRE	D1.03		1	2-L9				1	3-L4
BARRA DE ARRASTRE	D1.03.1		1	2-L10	CABINA Y APOYOS	L1.03		1	3-I10
BARRAS DEL CAMBIO DE VELOCIDADES	B2.10		1 1 2	2-H13/2-H14/2-H15	CAJA DE HERRAMIENTAS	L3.10	4	1	3-L17
BASTIDOR	D1.01		1	2-L8	CAJA DE TRANSMISION POSTERIOR	B1.02	1	1 2	2-I6 2-I5
BATERIAS	F3.01		1	2-S5	CAJA DEL VOLANTE	A1.02		1 2	1-H9 /1-H10
BIELAS	A1.05	1	1 2	1-H16/1-H17	CAJAS DE REDUCTORES LATERALES POSTERIORES	B4.11		1 2	2-I4 2-I3
BIELAS	A1.05 A	1	1	1-H17	CALORIFERO	E1.02		1	2-H10
BLINDAJE DE CADENAS	L3.11		1	3-M14	CAMBIADOR DE CALOR DEL ACEITE DEL MOTOR	A3.01	2	1	1-O10
BLINDAJE DE CADENAS	L3.11.1			3-M13	CAMBIADOR DE CALOR DEL CONVERTIDOR	B2.18		1	2-H16
BLINDAJE INFERIOR	L3.12		1	3-M12	CAMBIO DE VELOCIDADES	B2.30		1 1 1	1-P14/1-P15/1-P16
BLOQUE DE CILINDROS	A1.01	1	1	1-H4	CAMISA DE CILINDRO	A1.01	1	1	1-H4
BLOQUE DE CILINDROS	A1.01 A	1	1	1-H5	CAMISA DE CILINDRO	A1.01 A	1	1	1-H5
BOMBA DE ACEITE DEL MOTOR	A3.01	1	1	1-O12	CAPOT	L1.31		1/2 1	3-H17/3-H17/3-16

BENENNUNG	SGR.	TAV.	PAG.	GRID	BENENNUNG	SGR.	TAV.	PAG.	GRID
VENTIL	E3.34		1	2-3-10					
VENTIL F. RAUPENKETTENSANNER	D3.34	1	1/2	2-N2 2-N2					
VERBINDUNG DER RAUPENFAHRWERKRAHMEN	D3.31		1	2-M1					
VERSCHIEDENE ANTRIEBE	A1.15		1	1-1					
VERSCHIEDENE ANTRIEBE	A1.15 A		1	1-6					
VERSCHIEDENE GESTELLRAHMEN	L1.30		1	3-L6					
VERSCHIEDENE GESTELLRAHMEN	L1.30/ A		1	3-L7					
VERSCHIEDENE GESTELLRAHMEN	L1.30/ 1		1	3-L8					
VORD. KURBELGEHAEUSEDECKEL	A1.02	2	1	1-H11					
VORD. SCHEINWERFER	F4.01 A	2	1	2-T15					
VORD. SCHEINWERFER	F4.01/ 1	1	1	2-T16					
VORDERRADAUFHAENGUNG	D3.01		1	2-M7					
WAERMETALLISCHER FUER DREHMOMENTWANDLER	E.18		1	2-H16					
WASSERPUMPE	A.12	2	1 2 3	1-P2 1-P4 1-P5					
WECHSELGETRIEBE	R2.00		1 1 2	1-P14 1-P15 1-P16					
WERKZEUGE	H1.01		1	3-H10 3-H11					
WERKZEUGE	H1.01/ 1		1	3-H12 3-H13					
WERKZEUGE	H1.01/ 2		1	3-H14					
WERKZEUGKASTEN	L3.10	4	1	3-L17					
ZAHNRAEDER DER HINTEREN ENDANTRIEBE	B4.17		1	2-12					
ZAHNRAEDER F. MITTELACHSUNTERSETZUNG	B4.04		1	2-110/2-19					
ZAHNRAEDER F. MITTELACHSUNTERSETZUNG	B4.04/ A		1 2	2-18 2-7					
ZAPFWELLE	E2.16		1	2-N12					
ZENTRALE FEHLERSUCHANLAGE	B5.01		1	2-L2					
ZUERHOER	H1.07		1 1	3-H15 3-H16					
ZYLINDERKOPF	A1.01	2	1	1-H5					
ZYLINDERKOPF	A1.01/ A	2	1 2	1-H7 1-H8					
ZYLINDERKOPFDECKEL	A1.01	2	1	1-H5					
ZYLINDERKOPFDECKEL	A1.01/ A	2	1 2	1-H7 1-H8					
ZYLINDERLAUFBUESCHSE	A1.01	1	1	1-H4					
ZYLINDERLAUFBUESCHSE	A1.01/ A	1	1	1-H6					

BENENNUNG	SGR.	TAV.	PAG.	GRID	BENENNUNG	SGR.	TAV.	PAG.	GRID
MOTOR	A030	1		1-H2	RAUPENKETTENSCHUETZER	L311	1		3-M13
MOTORLUFTFILTER	A222	1/2		1-L8 /1-L9	REISSZAEHNE	E315	1		2-R2
MOTORLUFTVORREINIGER	A222	1/2		1-L8 /1-L9	ROPS-DACH	L308	1		3-L12
MOTORWASSERKUEHLER	A401	1	1/2	1-O6 /1-O5	SAUGKRUEMMER	A254	1	2	1-O15/1-O14
MOTORAUFMENGUNG	A002	1		1-H3	SAUGLEITUNGEN	A222	1	2	1-L8 /1-L9
MOTOROELFILTER	A301	1	1	1-O12	SCHALTBRETTELEUCHE	F401 A	1	1	2-T14
MOTOROELKUEHLER	A301	2	1	1-O10	SCHILD-SCHWENKZYLINDER	E302 5	2	1	2-O7
MOTOROELTHERMOMETER	F510	1		3-H9	SCHMIEROELPUMPE MOTOR	A301	1	1	1-O12
MOTOROELWANNE	A102	1	1/2	1-H9 /1-H10	SCHMIERUNG DER LENKREIBKUPPLUNGEN	D224	1		2-M13
MOTORSCHMIERUNG	A301	1	1/1	1-O12/1-O11/1-O10	SCHWINGUNGSDAEMPFER	A104	1		1-H15
				1-O8	SCHWUNGRADGEHAEUSE	A102	1	2	1-H9 /1-H10
MOTORSCHWUNGRAD	A103	1	1	1-H13	SCHALTUNG DER ZAPFWELLE	E215	1		2-M11
MOTORSCHWUNGRAD	A103 A	1	1	1-H14	SIGNALISIERVORRICHTUNGEN	F501	1		3-H8
MOTORVENTILE	A107	1	1/2	1/14/1/13	SIGNALISIERVORRICHTUNGEN	F101 1	1		3-M7
MOTORVENTILE	A107 A	1	1/2	1/12/1/11	SIGNALISIERVORRICHTUNGEN	F01 1A	1		3-H8
NOCKENWELLE	A107	1	1/2	1/14/1/13	SITZSCHUETZER	L310	1	2	3-L13B-L14B-L15
NOCKENWELLE	A107 A	1	1/2	1/12/1/11			1	1	3-L16B-L17B-M17
OELPUMPE	E328	1	2	2-R5 2-R6	SITZSCHUETZER	L310 1	1	1	3-M16 3-M15
OELDRUCKMESSER MOTOR	F510	1		3-H9	SPRITZZEITVERSTELLER	A224	1	1	1-L15
OELDRUCKMESSERGETRIEBE	F510	1		3-H9	STEUERUNGSANTRIEB	A106	1		1-L15
OELMESSSTAB GETRIEBE	E306	2	1	2-M11	STEUERUNGSANTRIEB	A 06 A	1		1-L15
OELMESSSTAB MOTOR	A301	1	1	1-O12	STEUERVENTIL DER LENKKUPPLUNGEN	D223	1	2/3	2-L15B-L16B-L17
PLANERSCHILD	E313 1	1		2-Q9	STROMERZEUGUNG	F901	1	1	2-S5 2-S4 2-S3
PLANERSCHILD	E313 2	1		2-Q8	STUFTZROLLE DER RAUPENKETTE	D139	1		2-M5
PLEUELSTANGEN	A105	1	1/2	1-H16/1-H17	THERMOSTAT	A402	1	2	1-O2 /1-P2
PLEUELSTANGEN	A105 A	1	1	1-H17	TILTZYLINDER	E302 6	1		2-O6
PUMPE DER LENKKUPPLUNGEN	D223	3	1/2	2-M15/2-M14	TRIEBRAD	D333	1		2-M3
RAHMEN	D101	1		2-L8	TRIEBRADWELLE	D333	1	1	2-M3
RAUPENFAHRWERKRAHMEN	D330	1		2-M5	TRITTBRETTER	L304	2	1	3-L11
RAUPENKETTE	D340 A	1	1	2-N7 /2-N8	UEBERTRAGUNG ZWISCHEN GETRIEBE UND HINTERACHSE	9301	1		2/12
RAUPENKETTE	D340 1	1		2-N9	UMGEHUNGSVENTIL	E302 1	1		1-O12
RAUPENKETTENSCHUETZER	L311	1		3-M14	UNTERE SCHUTZBLECHE	L312	1		3-M12

BENENNUNG	SGR.	TAV.	PAG.	GRID	BENENNUNG	SGR.	TAV.	PAG.	GRID
HINTERSCHWEINWERFER	F4.01/	1A	1	2-17	KETTENGLIEDER	D3.40/	1		2-N9
HINTERES FAHRWERKGEHÄUSE	B4.08	1	1/2	2-16/2-15	KETTENSCHNITTZYLINDER	D3.34	1	1/2	2-M2/2-N2
HINTERRADAUFHÄNGUNG	D3.05	1		2-M3	KIPPEBEL	A1.07	1	1/2	1-114/1-113
HUBARME FÜR ARBEITSGERÄTE	E3.10	1		2-P10	KIPPEBEL	A1.07/ A	1	1/2	1-112/1-111
HUBARME FÜR PLANIERGERÄTE	E3.10	1		2-P10	KOLBEN	A1.05	1	1/2	1-116/1-117
HUBARME FÜR PLANIERGERÄTE	E3.10/ 1	1		2-P11	KOLBEN	A1.05/ A	1	1	1-117
HUBARME FÜR PLANIERGERÄTE	E3.10/ 2	1		2-P12	KOTFLÜGEL	L3.04	1	1/2	3-L9/3-L10
HUBARME FÜR PLANIERGERÄTE	E3.10/ 3	1		2-P13	KRAFTSTOFFFILTER	A2.24	3	1/2	1-L17/1-M17
HUBARME FÜR PLANIERGERÄTE	E3.10/ 4	1		2-P14	KRAFTSTOFFFILTER	A2.24/ A	3	1	1-M13
HUBARME FÜR PLANIERGERÄTE	E3.10/ 5	1		2-P15	KRAFTSTOFFLEITUNGEN	A2.24/ A	2	1	1-M14
HUBARME FÜR PLANIERGERÄTE	E3.10/ 6	1/1		2-P16/2-P17	KRAFTSTOFFLEITUNGEN VOM TANK	A2.01		1/2	1-12/1-L2
HUBZYLINDER	E3.02	5	1	2-O16	KRAFTSTOFFPUMPE	A2.24	1	1	1-L15
HYDRAULISCHE STEUERUNG DER LENKREISKUPPLUNGEN	D2.23	1/2/3		2-L15/2-L16/2-L17	KRAFTSTOFFPUMPE	A2.24/ A	3	1	1-M13
		1/2/1		2-M17/2-M16/2-M15	KRAFTSTOFFTANK	A2.01		1/2	1-12/1-L2
		2		2-M14	KÜHLERLUFTLEITBLECH	A4.01	2	1	1-O4
HYDRAULIKANLAGE	E3.02	1/1/2		2-M13/2-M14/2-M15	KURBELGEHÄUSE	A1.01	1	1	1-N4
		1/1/1		2-M16/2-M17/2-O17	KURBELGEHÄUSE	A1.01/ A	1	1	1-N6
		1/1/1		2-O16/2-O15/2-O14	KURBELWELLE	A1.03	1	1	1-H13
		1		2-O13	KURBELWELLE	A1.03/ A	1	1	1-H14
HYDRAULIKANLAGE	E3.02/ 1	1		2-O12	KURBELWELLENLAGER	A1.03	1	1	1-H13
HYDRAULIKANLAGE	E3.02/ 2	1		2-O11	KURBELWELLENLAGER	A1.03/ A	1	1	1-H14
HYDRAULIKANLAGE	E3.02/ 3	1		2-O10	LAGERUNG DER ZYLINDER DES PLANIERGERÄTES	E3.06		1	2-P9
HYDRAULIKANLAGE	E3.02/ 4	1		2-O9	LAUFROLLE DER RAUPENKETTE	D3.37		1	2-N4
HYDRAULIKANLAGE	E3.02/ 5	1/1		2-O8/2-O7	LEITRAD	D3.34	2	1	2-N3
HYDRAULIKANLAGE	E3.02/ 6	1		2-O6	LEITRADLAGER	D3.31	2	1	2-N0
HYDRAULIKANLAGE	E3.02/ 7	1		2-O5	LENKREISKUPPLUNGEN	D2.20		1/1	2-L11/2-L12
HYDRAULIKANLAGE	E3.02/ 8	1		2-O4	LUEFTER	A4.09	1	1/2	1-P11/1-P12
HYDRAULIKPUMPE	E3.02	2	1/2	2-M14/2-M15	LUEFTER UND LUEFTERANTRIEB	A4.09/ 1	1	1	1-P13
INNERE GETRIEBESCHALTUNG	B2.10	1/1/2		2-M13/2-M14/2-M15	LUEFTERANTRIEB	A4.09	1	1/2	1-P11/1-P12
KENNZEICHEN	L4.10	1		3-M11	LUEFTERRIEMEN	A4.09	1	1/2	1-P11/1-P12
KETTENGLIEDER	D3.40	1	1	2-N6	LUEFTERRIEMENSANNER	A4.09	1	1/2	1-P11/1-P12
KETTENGLIEDER	D3.40/ A	1	1	2-N7	MODELLZEICHEN	L1.25		1	3-L5

ALPHABETISCHES VERZEICHNIS

BENENNUNG	SGR.	TAV.	PAG.	GRID	BENENNUNG	SGR.	TAV.	PAG.	GRID
AEUSSERE GETRIEBESCHALTUNG	B2 07	1		2-N12	DUESENHALTER	A2 24 A	4	1	1-M12
ANHAENGERKUPPLUNG	D1 03	1		2-L9	EINSPRITZPUMPE	A2 24	1	1	1-L15
ANHAENGERKUPPLUNG	D1 33-1	1		2-L10	EINSPRITZPUMPE	A2 24 A	1	1	1-M15
ANLASSEN DES MOTORS	F2 01	1		2-S9	EINSPRITZPUMPENANTRIEB	A1 16	1		1-5
ANLASSER	F2 01	1	1	2-S9	EINSPRITZPUMPENANTRIEB	A1 16 A	1		1-4
ANTRIEB F STUNDENZAehler UND DREHZAHLMESSEr	A1 03	1		1-110	FAHRERHAUS	L1 03-1	1		3-9
ANTRIEB F STUNDENZAehler UND DREHZAHLMESSEr	A1 03 A	1	2	1-9 1-8	FAHRERHAUS	L1 04	1	2	3-8 3-7 3-6
AUFREISSERZYLINDER	E3 02-2	1		2-011			1	2	3-5 3-4 3-3
AUSPUFFKRUEMMER	A2 54	1	2	1-0151-014			1	1	3-2 3-12 3-13
AUSPUFFROHR	A2 56	1		1-013			1		3-14
AUSBAUSTUNG FUR DEUTSCHLAND	M1 03	1		3-M5	FAHRERHAUS UND LAGER	L1 03	1		3-10
BATTERIEN	F3 01	1	1	2-S5	FAHRERSITZ	L6 01	1		3-M10
BELEUCHTUNG	F4 01	1	2	2-T5 2-T7 2-T8	FAHRERSITZ	L6 01-1	1		3-M9
			2	2-T9 2-T10 2-T11	FAHRERSITZ	L6 01-2	1		3-M8
			1	2-T12 2-T13	GASREGULIERUNG	A2 21	1	2	1-L3 1-L4 1-L5
BELEUCHTUNG	F4 01 A	1	1	2-T14 2-T15			2	1	1-L6 1-L7
BELEUCHTUNG	F4 01-1	1		2-T16	GEHAEUSE DER HINTEREN ENDANTRIEBE	B4 11	1	2	2-4 2-3
BELEUCHTUNG	F4 01-2	1		3-12	GERAETEDETAETIGUNG	E3 25	1	1	2-R3 2-R4
BELEUCHTUNG	F4 01-2A	1	2	3-M3 3-M4	GESTAENGE DER LENKKUPPLUNGEN	D2 22	2	1	2-L14
BELUFTUNGSLEITUNGEN FUER MOTOR	A1 25	1		1-8	GETRIEBEOLTHERMOMETER	F5 10	1		3-19
BETRIESSIGNALISIERUNG	F5 10	1		3-M9	GETRIEBESCHMIERUNG	B2 06	1	2	2-M9 2-M10 2-M11
BOXENPLATTEN	D3 40	1	1	2-K6	GETRIEBESPERRE	B2 36	1		2-13
BODENPLATTEN	D3 40 A	1	1	2-N7	HALTERUNG F ARBEITSGERAETE	E3 05	1		2-P8
BODENPLATTEN	D3 40-1	1		2-N9	HANDBREMSBETAETIGUNG	C1 35	1		2-L5
BREMSSAND	C1 01	2	2	2-L4 2-L5	HANDBREMSBETATIGUNG	C1 35 A	1		2-L7
BREMSPEDALE	C1 01	1	1	2-L3	HAUBE	L1 01	1	2	3-M17 1-M17 3-M16
DECKEL DES HINTEREN FAHRWERKS	B4 03	1	1	2-18 2-15			2	3	3-M13 3-M14 3-M13
DREHSTROMLICHTMASCHINE	F3 01	2	1	2-S4			2	1	3-M23 3-M11
DREHZAHMREGLER	A2 24	1	1	1-L15	HAUPTSTEUERVENTIL	E3 02	1	1	2-M13
DUESE	A2 24	4	1	1-M16	HEBEL DER LENKKUPPLUNGEN	D2 22	1	1	2-L13
DUESE	A2 24 A	4	1	1-M12	HEIZGERAET	E1 02	1		2-N10
DUESENHALTER	A2 24	4	1	1-M16	HINTERSCHWEINWERFER	F4 01-1	1		2-T16

DESIGNATION	SGR.	TAV.	PAG.	GRID	DESIGNATION	SGR.	TAV.	PAG.	GRID
SYSTEME HYDRAULIQUE	E3.02		4	1	2-03				
SYSTEME HYDRAULIQUE	E3.02		5	1/1	2-08 2-07				
SYSTEME HYDRAULIQUE	E3.02		6	1	2-06				
SYSTEME HYDRAULIQUE	E3.02		7	1	2-05				
SYSTEME HYDRAULIQUE	E3.02		8	1	2-04				
TEMONS DE FONCTIONNEMENT	F5		19	1	3-H9				
TENDEUR DE COUARDE DE VENTILATEUR	A4.09		1	1/2	1-P11 1-P12				
THERMOMETRE D'HUILE DE BOITE DE VITESSES	F5		10	1	3-H9				
THERMOMETRE D'HUILE MOTEUR	F5		10	1	3-H9				
THERMOSTAT	A4.02		1	1/2	1-02 1-02				
TILT CYLINDER	E3.02		6	1	2-06				
TRANSMISSION ENTRE B V ET PONT	B3.01			1	2-12				
TRIANGLE DE COMMANDE EMPAYAGES DE DIRECTION	D2.22		2	1	2-L14				
TULES	D3.40		1	1	2-N5				
TULES	D3.40		A	1	2-N7				
TULES	D3.40		1	1	2-N9				
TUYAUTERIES A COMBUSTIBLE	A2.24		A	2	1-M14				
TUYAUTERIES D'INSPIRATION	A2.22			1/2	1-L8 1-L9				
TUYAUTERIES DE VENTILATION DU MOTEUR	A1.25			1	1-N				
TUYAUTERIES SUR RESERVOIRS A COMBUSTIBLE	A2.01			1/2	1-N 1-L2				
VALVE DE REGLAGE DE ROUE TENDEUSE	D3.34		1	1/2	2-M2 2-N2				
VENTILATEUR	A4.09		1	1/2	1-P11 1-P12				
VENTILATEUR ET SA COMMANDE	A4.09		1	1	1-P13				
VERIN DE PIVOTEMENT DE LAME	E3.02		5	1	2-07				
VERIN DE RELEVAGE	E3.02		5	1	2-016				
VERIN DE RIPPER	E3.02		2	1	2-011				
VERIN DE TENDEUR DE CHENILLE	D3.34		1	1/2	2-M2 2-N2				
VILEBR EQUIN	A1.03			1	1-M13				
VILEBR EQUIN	A1.03		A	1	1-M14				
VOLAN MOTEUR	A1.03			1	1-M13				
VOLAN MOTEUR	A1.03		A	1	1-M14				

DESIGNATION	SGR.	TAV.	PAG.	GRID	DESIGNATION	SGR.	TAV.	PAG.	GRID
MAILLONS	D3.40	1		2-N9	PROTECTIONS DE CHENILLES	L3.11	1		3-M13
MANOMETRIE D'HUILE DE BOITE DE VITESSES	F5.10	1		3-H9	PROTECTIONS DE SIEGE	L3.10	1	1/2	3-L13/3-L14/3-L15
MANOMETRIE D'HUILE MOTEUR	F5.10	1		3-H9			1	1/1	3-L16/3-L17/3-M17
MARCHEPIEDS	L3.04	2	1	3-L11	PROTECTIONS DE SIEGE	L3.10	1	1	3-M16/3-M15
MOTEUR	A0.00	1		1-H2	PROTECTIONS INFERIEURES	L3.12	1		3-M12
MOTIFS	L1.25	1		3-L5	RADIATEUR A EAU DE MOTEUR	A4.01	1	1/2	1-O6 /1-O5
MOTIFS	L4.10	1		3-M11	RECHAUFFEUR	E1.02	1		2-N10
ORGANE D'ATTELAGE	D1.03	1		2-L6	REGULATEUR DE VITESSE	A2.24	1	1	1-L15
ORGANE D'ATTELAGE	D1.03/1	1		2-L10	RESERVOIR A COMBUSTIBLE	A2.01	1	2	1-H2 1-L2
OUTILS	H1.01	1	1	3-M10/3-M11	RESERVOIR D'HUILE	E3.28	1	2	2-R5 2-R6
OUTILS	H1.01/1	1	1	3-M12/3-M13	ROUE TENDEUSE	D3.34	2	1	2-N3
OUTILS	H1.01/2	1		3-M14	SANGLE DE FREIN	C1.01	2	1/2	2-L4 2-L5
PEDALES DE FREINS	C1.01	1	1	2-L3	SEGE VE CONDUCTEUR	L6.01	1		3-M10
PISTONS	A1.05	1	1/2	1-H16/1-H17	SEGE DE CONDUCTEUR	L6.01/1	1		3-M9
PISTONS	A1.05/A	1	1	1-H17	SEGE DE CONDUCTEUR	L6.01/2	1		3-M8
POMPE A EAU	A4.02	2	1/2 3	1-P3 1-P4 1-P5	SOUPAPE	E3.34	1		2-S10
POMPE A HUILE DE GRAISSAGE MOTEUR	A3.01	1	1	1-O12	SOUPAPES DE DISTRIBUTION	A1.07	1	1/2	1-H14/1-H13
POMPE D'ALIMENTATION	A2.24	1	1	1-L15	SOUPAPES DE DISTRIBUTION	A1.07/A	1	1/2	1-H12/1-H11
POMPE D'ALIMENTATION	A2.24/A	3	1	1-M13	STRUCTURE DE PROTECTION ROPS	L3.09	1		3-L12
POMPE D'EMBRAYES DE DIRECTION	D2.23	3	1/2	2-M15/2-M14	SUPPORT DE ROUE TENDEUSE	D3.34	2	1	2-N3
POMPE D'INJECTION	A2.24	1	1	1-L15	SUPPORTS DE CYLINDRES DE LANE DOZER	E3.06	1		2-P9
POMPE D'INJECTION	A2.24/A	1	1	1-M15	SUPPORTS DES OUTILS	E3.05	1		2-P8
POMPE D'INSTALLATION HYDRAULIQUE	E3.02	2	1/2	2-M14/2-N15	SUSPENSION AR	D3.05	1		2-M6
PORTE-INJECTEURS	A2.24	4	1	1-M16	SUSPENSION AV	D3.01	1		2-M7
PORTE-INJECTEURS	A2.24/A	4	1	1-M12	SUSPENSIONS DU MOTEUR	A0.02	1		1-H3
PREFILTRE A AIR DE MOTEUR	A2.22	1/2		1-L8 1-L9	SYSTEME HYDRAULIQUE	E3.02	1/1/2		3-N13 2-N14/2-N15
PRISE DE FORCE	E2.16	1		2-N12			1/1/1		2-N16/2-N17/2-O17
PROJECTEUR ARRIERE	F4.01/1	1		2-T16			1/1/1		2-O16/2-O15/2-O14
PROJECTEUR ARRIERE	F4.01/1A	1		2-T7			1		2-O13
PROJECTEUR AVANT	F4.01/A	2	1	2-T15	SYSTEME HYDRAULIQUE	E3.02/1	1		2-O12
PROJECTEUR AVANT	F4.01/1	1	1	2-T16	SYSTEME HYDRAULIQUE	E3.02/2	1		2-O11
PROTECTIONS DE CHENILLES	L3.11	1		3-M14	SYSTEME HYDRAULIQUE	E3.02/3	1		2-O10

	DESIGNAZIONE BASE	BASIC DESIGNATION	DESIGNATIONS-BASES	GRUNDBEZEICHNUNGEN	DENOMINACIONES BASE
11L	LAMA ANGLEDOZER	ANGLE MOLDBOARD	LAME BIASE	SCHWENKENSCHILD	HOJA ANGULABLE
11V	VALVOLA DI PROTEZIONE	PROTECTION VALVE	SOUPAPE DE PROTECTION	SICHERHEITSVENTIL	VALVULA DE PROTECCION
11V					
113	RIPARO TUBAZ CILINDRI	CYLINDERS P/PIPING GUARD	PROTECTION TUYAUTES CYLINDR	LEITUNGEN ZY LINDER SCHUTZ	
12A	ALBERO PRIMARIO	MAIN SHAFT	ARBRE PRIMAIRE	HAUPTWELLE	ARBOL PRIMARIO
12B	BARRA DI TORSIONE	TORSION B/R	BARRE DE TORSION	DREHSTAB	BARRA DE TORSION
12F	FANALE DEL CRUSCOTTO	INSTRUMENT LAMP	LAMPE DE TABLIER	SCHALTBRETTLEUCHTE	LUZ DEL TABLERO
12L	LAMA BULLDOZER	DOZER MOLDBOARD	LAME DROITE	GERADEM SCHILD	HOJA RECTA
12M	MAGNETE	MAGNETC	MAGNETO	MAGNET	MAGNETO
12O	OCCHIELLO	EYELET	OEILET	OESE	OJAL
12V	VALVOLA ELETTROPNEUMATICA	ELECTR/PNEUMATIC VALVE	SOUPAPE ELECTRO-PNEUMATIQUE	ELFKTROPNEUMATISCHES VENTIL	VALVULA ELECTRO-NEUMATICA
12V					
13A	ALBERO SECONDARIO	COUNTERSHAFT	ARBRE SECONDAIRE	VORGELEGEWELLE	ARBOL SECUNDARIO
13B	BARRA DI TRAINO	DRAWBAR	BARRE D'ATTELAGE	ZUGSTANGE	BARRA DE REMOLQUE
14B	BANDELLA	STRAP	BANDE	BAND	LARGUERO
14F	FANALE DELLA TARGA	NUMBER PLATE LAMP	FEU DE PLAQUE	NUMMERSCHILDLEUCHTE	LUZ DE MATRICULA
14F					
14O	OGIVA	OGIVE	CONE	DICHTKEGEL	EMPALME CONICO
14V	VANO	COMPARATMENT	NACELLE	NISCHE	CAVIDAD
15C	CALANDRA DEL RADIATORE	RADIATOR GUARD	CALANDRE DE RADIATEUR	KUEHLERHAUBE	CALANDRA DE RADIADOR
15C					
15F	FANALE RETROMARCIA	BACK-UP LAMP	FEU DE RECU	RUECKFAHRLEUCHTE	LUZ DE MARCHIA ATRAS
15G	GABBIA	CAGE	CAGE	LAGERKAEFIG	JAULA
15L	LAMELLA ELASTICA	REED	LAMELLE ELASTIQUE	LAMELLE	LAMINILLA ELASTICA
15M	MANCORRENTE	HAND-RAIL	MAIN COULANTE	HALTEGRIF	BARANDILLA
15N	NASELLO	DOG	CROCHET	KEILNASE	TOPE
15O	OLIATORE	LUBE FITTING	BURETTE	SCHMIERKANNE	ACEITERA
15R	RALLENTATORE IDRAULICO	HYDRAULIC DECELERATOR	RALENTISSEUR	HYDRAULISCHE	RETARDADOR HIDRAULICO
15R					
15T	TACHIGRAFO	TACHOGRAPH	TACHYGRAPHE	DREHZAHLMINDERER	TACOMETRO REGISTRADOR
15T					
15V	VALVOLA A SPILLO	NEEDLE VALVE	POINTEAU	SCHWIMMERNADEL-VENTIL	VALVULA DE AGUJA
15V					
15O	SILENZIATORE CON PARAFIAMMA	SPARK ARRESTING MUFFLER	SILENZIEUX PARAFLAMME	AUSPUFFTOPF MIT FUNKENSCHUTZ	
15I	COPERCHIETTO PARAPIOGGIA	RAIN CAP	COUVERCLE PAREPLUIE	AUSPUFFKLAPPE	
16A	ALBERO	SHAFT	ARBRE	WELLE	ARBOL
16F	FANALE POSTERIORE E TARGA	TAIL AND NUMBER PLATE LAMP	LANTERNE AR ET DE PLAQUE	SCHLUSS- U NUMMERSCHILDLEUCHTE	LUZ POSTERIOR Y DE MATRICULA
16F					
16G	GABBIA A SFERE	BALL CAGE	CAGE A BILLES	KUGELKAEFIG	PORTABOLAS
16R	RACCORDO A 3 VIE	TEE	RACCORD A 3 VOIES	HOSENROHR	RACOR DE 3 BOCAS

	DESIGNAZIONE BASE	BASIC DESIGNATION	DESIGNATIONS BASES	GRUNDBEZEICHNUNGEN	DENOMINACIONES BASE
5D	DAL CILINDRO...	FROM TO CYLINDER	A PARTIR DU CYLINDRE	AB ZYLINDER	A PARTIR DEL CILINDRO
5F	FINDO AL CILINDRO...	UP TO CYLINDER...	JUSQU'AU CYLINDRE	BIS ZYLINDER	HASTA EL CILINDRO
59	SCAVO LATERALE	OFFSET BOOM			
6V	VALVOLA AMMORTIZZATRICE	DAMPING VALVE	SOUPAPE AMORTISEUSE	DAEMPFUNGSVENTIL	VALVOLA AMORTIGUADORA
60	RETROSCAVATORE	BACKHOE	PELLE RETRO	HECKBASSER	RETROEXCAVADORA
7A	AD ESURIMENTO	UP TO EXHAUSTION	A EPUISEMENT	NACH AUFBRUCH	HASTA AGOTARSE
7B	MOLLA PRINCIPALE	MAIN SPRING	RESSORT PRINCIPAL	HAUPTFEDER	RESSORT PRINCIPAL
7V	VALVOLA SOVRAPRESSIONE	OVERPRESSURE VALVE	SOUPAPE DE SURPRESSION	UEBERDRUCKVENTIL	VALVOLA DE SOBREPRESION
79	MARTELLO DEMOLITORE		MATEAU DE DIMOLITION	ABBRUCHHAMMER	
71	TAGLIENTE BENNA	BUCKET CUTTING EDGE	COTEAU DU GOBET	SCHAUFELSCHNEIDE	
72	RIPARO SUPERIORE BENNA	BUCKET SPILL PLATE			
89	MOLLA A BALESTRA	LEAF SPRING	RESSORT A LAMES	BLATTFEDER	MUELLE DE BALLESTA
8C	CABINA	CAB	CABINE	FAHRERHAUS	CABINA
8D	DECALCOMANIA	DECAL	DECALCOMANIE	ABZIEHBILD	DECALCOMANIA
85	DENTE CON PUNTA RIPORTATA	SHANK WITH REPLACEABLE TOOTH	D'ENT AVEC POINTE AMOVIBLE	ZAHN MIT EINGESETZTER SPITZE	DIENTE CON PUNTA REEMPLAZABLE
87	DENTI CON PUNTA RINFORZATA	TOOTH WITH REINFORCED TIP	DENT AVEC POINTE RENFORCEE	ZAHN MIT VERSTAERKTER SPITZE	
88	DENTI CON PUNTA RIPORTATA (SALDI)	TOOTH WITH WELDED TIP	DENT AVEC POINTE SOUDEE	ZAHN-EINGESETZTER SPITZENGESCH	
89	BRACCIO GRU	CRANE BOOM	BRAS DE GRUE	KRANARM	
9F	FANALE	LIGHT	FEU	SCHWENKWERFER	FAROL
9R	RACCOGLITORE	TRAY	CLASSEUR	DELFANGBLECH	CARTER
9V	VALVOLA SICUREZZA	SAFETY VALVE	SOUPAPE DE SURETE	SICHERHEITSVENTIL	VALVOLA DE SEGURIDAD
91	PROTEZIONE DENTI BENNA	BUCKET TOOTH GUARD	PROTECTION DENTS DE GOBET	SCHAUFELZAHNSCHUTZ	PROTECCION DIENTE DE CUCHARA
92	CORPO DENTE	BUCKET TOOTH SHANK	CORPS DE DENT	ZAHNHALTER	
105	COMPLESSIVI	ASSEMBLY DRAWINGS	ENSEMBLES	GESAMTZEICHNUNGEN	
109	COMPLESSIVI PER PRODUZIONE	ASSEMBLY DWGS FOR MANUFACTURING	ENSEMBLES POUR PRODUCTION	FERTIGUNGSZEICHNUNGEN	
11A	AERATORE	VENT	AERATEUR	LUEFTER	ASPIRADOR
10C	CACCIAVITE	SCREWDRIVER	TOURNEVIS	SCHRAUBENZIEHER	DESTORNILLADOR
10D	DADO	NUT	ECROU	MUTTER	TUERCA
10E	ECCENTRICO	ECCENTRIC	EXCENTRIQUE	EXZENTRISCH	ECCENTRICA
10I	IDROQUIDA	HYDRAULIC DRIVE	DIRECTION HYDRAULIQUE	HYDROSTATISCHE LENKUNG	MANDO HIDRAULICO DE DIRECCION
10L	LAMA	MOLDBOARD	LAME	SCHILD	HOJA
10M	MAGLIA	LINK	CHAINON	GLIED	MALLA
10Q	QUADRO SEGNALAZIONI OTTICHE	INDICATOR PANEL	TABLEAU DE TEMOINS	ANZEIGENTAFEL	CUADRO DE SENALIZACIONES
10Q					
10R	RACCOGLIOLIO	OIL COLLECTOR	COLLECTEUR D HUILE	OELFANGER	COLECTOR DE ACEITE
10V	VALVOLA	VALVE	SOUPAPE	VENTIL	VALVULA
10Z	ZAVORRA	COUNTERWEIGHT	LEST	KONTERGEWICHT	LASTRE
103	PESATURA ELETTRONICA	WEIGHING SYSTEM			
11A	ALBERINO	SPINDLE	ARBRE	WELLE	ARBOL
11B	BARRA STABILIZZATRICE	STABILIZER BAR	BARRE STABILISATRICE	STABILISATOR	BARRA ESTABILIZADORA

DESIGNAZIONE BASE	BASIC DESIGNATION	DESIGNATIONS-BASES	GRUNDZEICHNUNGEN	DENOMINACIONES BASE
C	COMPL	ASSY	COMPLET	COMPLETO
1	MOTORE SOVRALIMENTATO	TURBOCHARGED ENGINE	MOTOR SURALIMENTE	
3	RISCALDATORE IMP RA/FR MOTORE	ENGINE COOLANT HEATER	CHAUFFAGE D'EAU MOTEUR	CALEFACCION AGUA MOTOR
G5	ELENCO VARIANTI - TRATTORI	SPEC.EQUIPMENT LIST - TRACTOR	LISTE DE VARIATIONS - TRACTEUR	
G6	ELENCO VARIANTI - ATTREZZI	SPEC.EQUIPM LIST - IMPLEMENT	LISTE DE VARIATIONS - OUTIL	
G7	ELENCO VARIANTI-ALLIED EQUIP	ALLIED EQUIPMENT LIST		
1A				
1K	KIT VED. PAG.9	KIT SEE PAGE 9	KIT VOIR PAGE 9	KIT SEITE 9
1M	MICROFICHE SERVICE	MICROFICHES SERVICE	MICROFICHES SERVICE	MICROFICHE SERVICE
1N	NASTRÒ MAGNETICO	MAGNETIC TAPE	BANDE MAGNETIQUE	BANDA MAGNETICA
2C	CATALOGO PARTI RICAMBI	PARTS CATALOG	CATALOGUE PIECES DETACHEES	CATALOGO PIEZAS REPUESTO
2D	DATI CARATT PER RIPARAZIONI	SERVICE SPECIFICATIONS	DONNEES POUR LES REPARATIONS	DATOS CARACT.PARA REPARACIONES
2E	ELENCO GENERALE RICAMBI	MASTER NUMERICAL INDEX	LISTE GENERAL PIECES RECHANGE	LISTA GENERAL PIEZAS REPUESTO
2F	FINO AL MOTORE	UP TO ENGINE	JUSQUA MOTEUR	HASTA EL MOTOR...
2K	KIT	KIT	KIT	JUEGO
2L	LISTINO PREZZI RICAMBI	PARTS PRICE LIST	TARIF PIECES DE RECHANGE	LISTA DE PRECIOS DE REPUESTOS
2M	MANUALE PER LE RIPARAZIONI	SERVICE MANUAL	MANUEL D'ATELIER	MANUAL DE SERVICIO
2N	NOTIZIARIO TECNICO RICAMBI	PARTS BULLETIN	BULLETIN DE PIECES DETACHEES	NOTICIARIO PIEZAS DE REPUESTO
2T	TABELLE TARATURA APP INIEZIONE	INJECT SYST CALIBRATION CHARTS	TABLE TARAAGE APPAR INJECTION	TABLAS TARADO APAR INYECCION
2D	INSONORIZZAZIONE POSTO GUIDA	CAB SOUND SUPPRESSION	INSONORIZATION POSTE CONDUITE	INSONORIZACION PUESTO-CONDUCC
21	WINTERIZZAZIONE	WINTERIZATION		
22	INSONORIZZAZIONE ESTERNA	BYSTANDER SOUND SUPPRESSION	INSONORIZATION EXTERIEURE	INSONORIZACION EXTERNA
24	TRASFORA CIRCOL SU STRADA (FG)	ROAD TRAFFIC PREPARATION (FG)		
26	PREDISPOSIZIONE T/V	TUV VERSION	VERSION TUV	
3B	BADILE	SHOVEL	PELLE	PALA
3C	CATALOGO ATTREZZATURE ASSIST	SERVICE TOOL CATALOG	CATALOGUE OUTILAGE ASSISTANCE	CATALOGO UTILAJE SERVICIO
3D	DAL MOTORE	FROM THE ENGINE	A PARTIR DU MOTEUR	A PARTIR DEL MOTOR
3F	FINO AL CAMBIO	UP TO TRANSMISSION	JUSQUA LA BOITE DE VITESSE	HASTA EL CAMBIO
3M	MANUALE ISTR USO MANUTENZIONE	OPERAT MAINTEN INSTR MANUAL	MANUEL CONDUIT ET ENTRETIEN	MANUAL INSTR.MANEYO Y MANTENIM
3T	TARIFARIO DELLE RIPARAZIONI	REPAIR TIME MANUAL	MANUEL TEMPS REPARATION	MANUAL TIEMPOS REPARACIONES
30	OMOLOGAZIONE ITALIA	ITALIAN ROAD TRAFFIC APPROVAL	HOMOLOGATION ITALIE	HOMOLOGACION ITALIA
31	ALLESTIMENTO NEW YORK	NEW YORK VERSION		
35	OMOLOGABILE AGRICOLA	FARM PROVISION	HOMOLOGABLE AGRICULTURE	LANDWIRTSCHAFTSZULASSUNG
4D	DAL TELAIO	FROM SERIAL NO	A PARTIR DU CHASSIS	A PARTIR DEL CHASIS
4F	FINO ALLA CABINA	UP TO CAB	JUSQUA LA CABINE	HASTA LA CABINA...
4M	MANUALE ADDESTR.ASSISTENZIALE	SERVICE TRAINING MANUAL	MANUEL FORMATION TECHNIQUE	MANUAL DE FORMACION TECNICA
4T	TAVOLA MURALE	WALL CHART	PLANCHE MURALE	LAMINAS DIDACTICAS
45	RIPARO SERBATOIO COMBUSTIBILE	FUEL TANK GUARD	PROTECTION RESERVOIR COMB	
46	RIPARO INF SERBATOIO COMBUST	FUEL TANK LOWER GUARD	PROTECTION INF.RESERVOIR COMB	
5A	ACCENDISIGARI	CIGARETTE LIGHTER	ALLUME-CIGARE	ENCENDEDOR

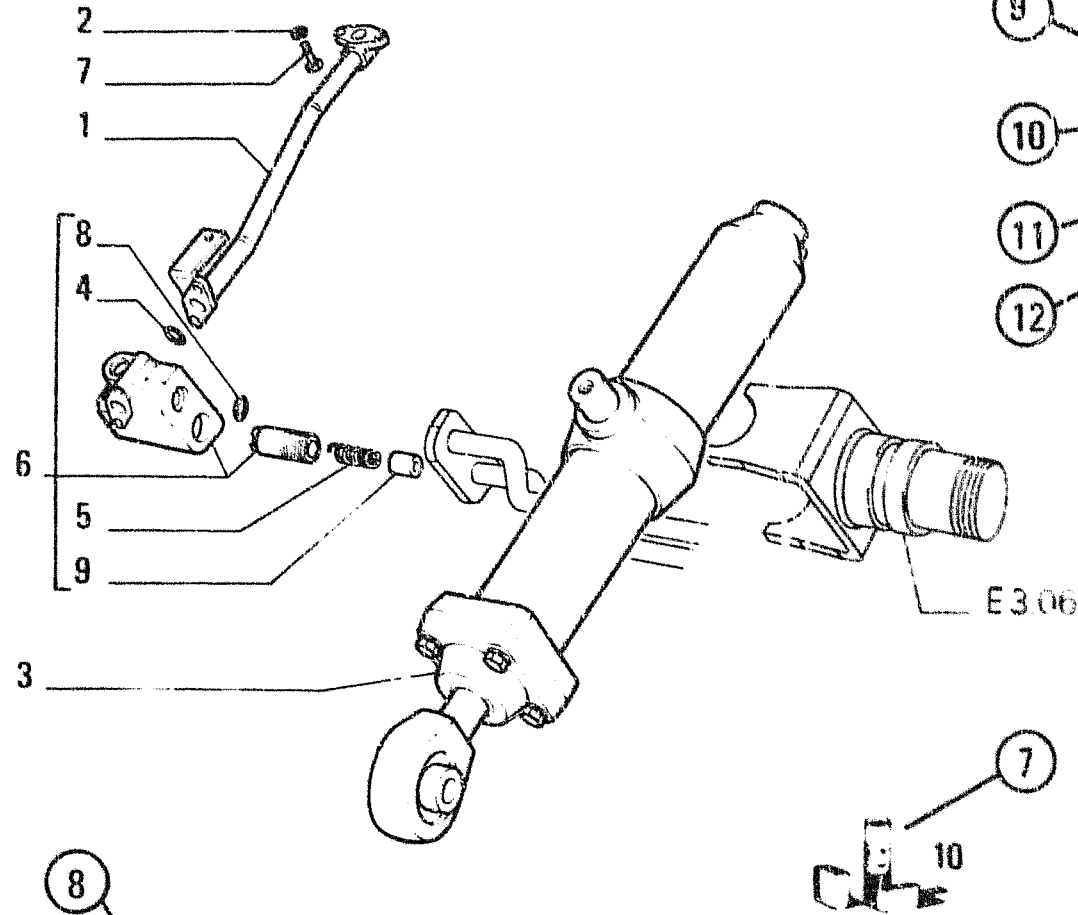

C 935 → tel.n. 076204

Optional Variante 30.1070.06.1

ITEM	PART NUMBER	QTY	TRANS CODE	DESCRIPTION	DESCRIZIONE
9	4318965	1		193T PIPE - RIGHT	TUBO - DESTRO
10	4513436	1		193T PIPE - RIGHT (*)	TUBO - DESTRO (*)
	4606783	1		193T PIPE - LEFT	TUBO - SINISTRO
	C 951			C 951	C 951
11	79021573	1		193T PIPE - LEFT	TUBO - SINISTRO
12	D 951			D 951	D 951
2	12638601	2		131R WASHER 10x18	ROSETTA 10x18
3	4606780	1		164C CYLINDER - RIGHT ASSEMBLY SEE SGR E3 32	CILINDRO - DESTRO COMPLETO VEDERE SGR E3 32
	4606787	1		164C CYLINDER - LEFT ASSEMBLY SEE SGR E3 32	CILINDRO - SINISTRO COMPLETO VEDERE SGR E3 32
	C 951			C 951	C 951
	79021574	1		164C CYLINDER - LEFT ASSEMBLY D 951	CILINDRO - SINISTRO COMPLETO D 951
4	4606788	1		55A SEAL - WRONG	ANELLO DI TENUTA - ERRATA
	4606789	1		55A SEAL - CORRECT	ANELLO DI TENUTA - CORRETTA
5	4606790	1		100MM SPRING	MOLLA
6	4606791	1		10V VALVE - RIGHT ASSEMBLY	VALVOLA - DESTRO COMPLETO
	4606792	1		10V VALVE - LEFT ASSEMBLY	VALVOLA - SINISTRO COMPLETO
	C 951			C 951	C 951
	79021576	1		10V VALVE - LEFT ASSEMBLY D 951	VALVOLA - SINISTRO COMPLETO D 951
7	11307921	2		407/ SCREW 10x1.25x40	VITE 10x1.25x40
8	11453381	1		56A SEAL 1.78x15.00	ANELLO DI TENUTA 1.78x15.00
9	4106795	1		507 PLUG	TAPPO
10	79121577	K		1K KIT SEE PAGE 9	CORREDO VEDERE PAGINA 9
	(*)			480P FOR OPTIONAL 30 1070 06 1	PER VARIANTE 30 1070 06 1

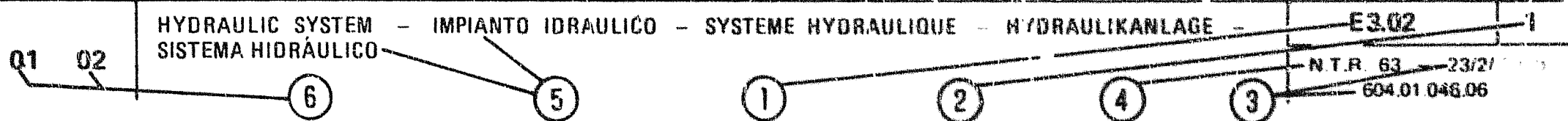

2/3

C1

E3.02

N.T.R. 63 23/2/ 604.01 046.06

CÓMO SE MANEJA EL CATÁLOGO

Para buscar correcta: **ente las piezas de repuesto, sea preciso:**

- consultar la lista de revisiones pág. 4, para identificar, en su caso, el código numérico de la versión que interesa; véase el siguiente párrafo 1, punto 6.
- consultar las láminas, las respectivas listas de piezas de repuesto y la tabla de modificaciones conforme se explica en los párrafos 1, 2 y 3;
- para los modelos que comprenden variantes, consultar la lista de variantes pág. 5, donde se indica incluso el correspondiente número de código por orden progresivo, y la lista de los subgrupos afectados.

1. Láminas (véase el ejemplo, a pág. 29)

Representan las piezas de repuesto de cada subgrupo en que se divide la máquina. Las piezas de repuesto representadas se designan mediante un número de referencia (ITEM), el cual podría ir sustituido por otras indicaciones: ejemplo:

E3.06: pieza ilustrada únicamente en el Sgr E3.06

Además, en cada lámina figuran:

El código del subgrupo (1) — el número de la hoja (2), cuando el mismo subgrupo comprende más de una lámina — la indicación de su revisión (3); ejemplo: el sufijo 05, que se agrega al número de la publicación 604.01.046, significa que el subgrupo ha sido modificado en la 1ª revisión del catálogo, editado en fecha de 23 de febrero de 1955; de carecer la indicación (3), significa que no ha habido modificaciones. — la indicación, en su caso, de la publicación de la revisión (4) — la denominación del subgrupo (5) — el código de la versión (6), con referencia al punto (a) que antecede. e faltar ese código, se entiende que la lámina es aplicable a todas las versiones del modelo de que se trata en el catálogo. — la indicación de la existencia de fornituras de recambio (7), con los respectivos números de referencia (véase en la pag. 9 la composición de las firmas). — validez — (8) (además de la validez para la versión a que se refiere el código 6): C 935 - tel. n° 076204 significa que la lámina, a raíz de la modificación 935, es aplicable hasta la máquina con número de bastidor 076204, D 935 tel. 076205 → significa que la lámina, a raíz de la modificación 935, es aplicable a partir de la máquina con número de bastidor 076205.

Para mayores datos sobre las modificaciones, véase la tabla de modificaciones de que se trata más adelante en el párrafo 3

2. Listas de las piezas de repuesto (véase el ejemplo en la pag. 29)

En ellas se reseñan las piezas de repuesto de cada subgrupo representadas en las láminas correspondientes, indicando para cada pieza:

(9) ITEM, el número de cada pieza representada que se acompaña a su «part number» (= número de catálogo).

(10) PART NUMBER número de catálogo de cada pieza de repuesto

(11) C TY número total de la pieza, representada en la lámina, este número puede reemplazarse con las indicaciones siguientes: L = se entrega en trozos de suficiente longitud; K = fornitura que debe encargarse en la cantidad deseada.

(12) TRANS. CODE: código para buscar la traducción al francés, alemán y español de la denominación (consultese la lista de las denominaciones básicas al final del catálogo, o el opusculo 604 01 105)

(13) DESCRIPTION DENOMINAZIONE: denominación de la pieza en Inglés e Italiano.

En caso de modificaciones, a la denominación se acompaña la indicación siguiente: (14) 4606783

C 951 = pieza anterior a la modificación 951;

(15) 79021573

D 951 = pieza posterior a la modificación 951.

Ver en la tabla de modificaciones de que se trata en el párrafo 3, la indicación de cómo se aplica la modificación y las eventuales normas de recambio.

Otras indicaciones útiles (16) pueden consignarse en la columna DESCRIPTION: DENOMINAZIONE, después de signo — (la traducción de estas voces del inglés o italiano al francés, alemán y español, figura en la lista de voces suplementarias que precede a la lista de denominaciones básicas al final del catálogo, o al principio del opusculo 604.01. 105. La voces RIGHT/DERECHO y LEFT IZQUIERDO se refieren al sentido de marcha de la máquina. Suponiendo que a una denominación se acompañe la palabra WRONG/DONDE DICE, y en el renglón siguiente no aparezca la correspondiente CORRECT/LÉASE, significa que la pieza sobra, por un error

(17) Subgrupo, número de la lámina (si acaso el subgrupo comprende grabados diversos), número de la página (si acaso la lista de piezas de repuesto de una misma lámina ocupa más de una página)

(18) Número de código de la variante: indica que las piezas reseñadas y contraseñadas con (*) pertenecen a aquella misma variante. En cambio, si el código aparece tan sólo en la lámina, significa que todas las piezas de ese subgrupo pertenecen a esa variante (véase el punto c) que antecede)

(19) Dimensiones de las piezas normalizadas

3. Tablas «MODIFICACIONES» (reseñadas en las hojas M al final del catálogo)

En ellas se reseñan todas las modificaciones incorporadas a la máquina durante su producción, las aplicaciones habidas y las eventuales normas de recambio, indicaciones y abreviaturas

→ C 851 → tel. n° 004652 = piezas anteriores a la modificación 851, montadas en las máquinas, hasta el num. 004652 del bastidor

→ D 851 tel. n° 004653 → = piezas posteriores a la modificación 851, montadas en las máquinas a partir del num. 004653 del bastidor

En las columnas «Subgrupos afectados y normas de recambio» se reseñan los subgrupos afectados por las diversas modificaciones y las eventuales normas de recambio. Ejemplo de normas de recambio:

4606783 = 79021573, como se agota la provisión de la pieza 4606783 coloque la nueva 79021573.

4606787 = 79021574 + 79021576: como se agota la provisión de la pieza 4606787, coloque las nuevas 79021574 y 79021576;

4606792 = 79021576 - 4606794: como se agota la provisión de la pieza 4606792, coloque la nueva 79021576 y elimine la 4606794.

Suponiendo que no se indiquen normas de recambio, significa que hay que seguir entregando recambios de las piezas antemodificación, por no ser intercambiable con aquella postmodificación.

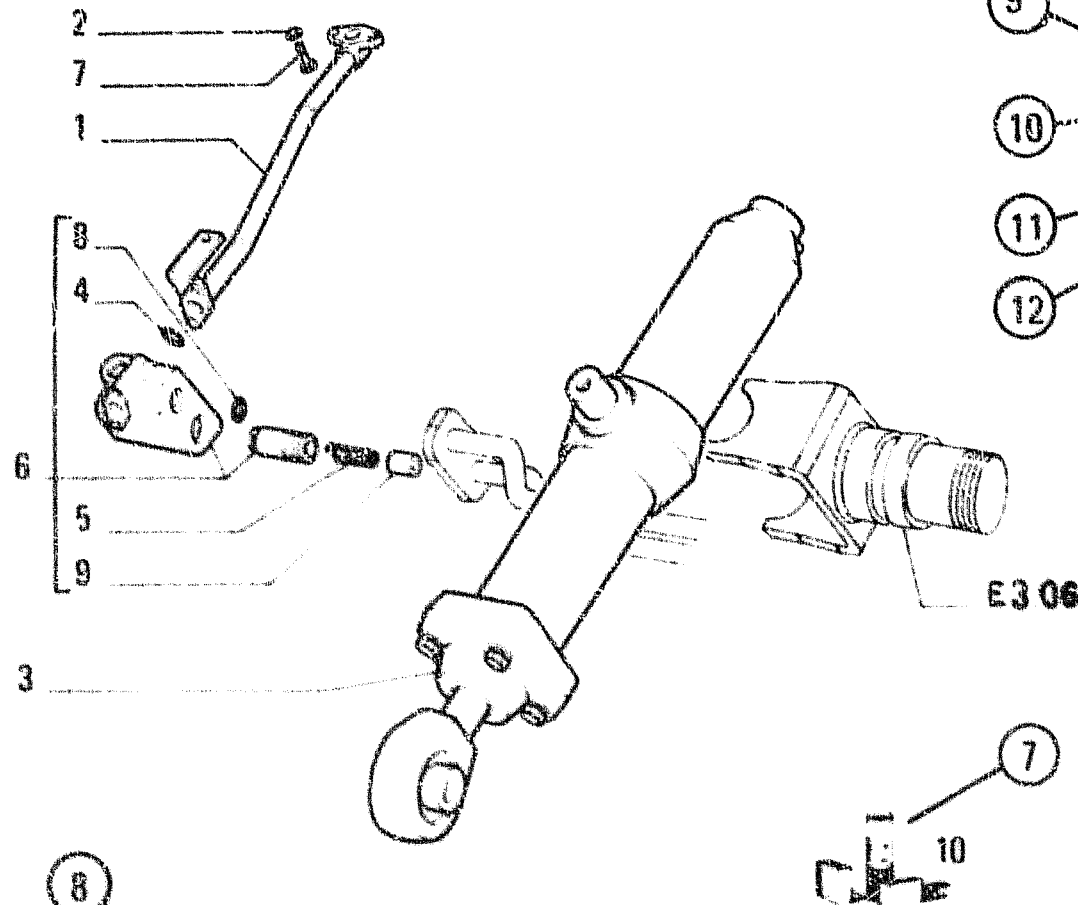

C 935 -> ref. n. 076204

Optional Variante 30 1070 06 1

ITEM	PART NUMBER	QTY	TRANS CODE	DESCRIPTION	DESCRIZIONE
9	4318955	1		193T PIPE - RIGHT	TUBO - DESTRO
10	4513436	1		193T PIPE - RIGHT (*)	TUBO - DESTRO (*)
	4606783	1		193T PIPE - LEFT	TUBO - SINISTRO
	C 951				C 951
11	79021573	1		193T PIPE - LEFT	TUBO - SINISTRO
	D 951				D 951
12	2	12639601	2	131R WASHER 10x18	ROSETTA 10x18
	3	4606796	1	164C CYLINDER - RIGHT ASSEMBLY SEE SGR E3 32	CILINDRO - DESTRO COMPLETO VEDERE SGR E3 32
15	4606787	1		164C CYLINDER - LEFT ASSEMBLY SEE SGR E3 32	CILINDRO - SINISTRO COMPLETO VEDERE SGR E3 32
	C 951				C 951
16	79021574	1		164C CYLINDER - LEFT ASSEMBLY D 951	CILINDRO - SINISTRO COMPLETO D 951
	4	4606785	1	55A SEAL - WRONG	ANELLO DI TENUTA - ERRATA
16	4606789	1		55A SEAL - CORRECT	ANELLO DI TENUTA - CORRETTO
	5	4606790	1	100M SPRING	MOLLA
16	6	4606791	1	10V VALVE - RIGHT ASSEMBLY	VALVOLA - DESTRO COMPLETO
	4606792	1		10V VALVE - LEFT ASSEMBLY	VALVOLA - SINISTRO COMPLETO
19	C 951				C 951
	79021576	1		10V VALVE - LEFT ASSEMBLY D 951	VALVOLA - SINISTRO COMPLETO D 951
19	7	11307021	2	40V SCREW 10x1.25x40	VITE 10x1.25x40
18	8	14453381	1	55A SEAL 1.78x15.60	ANELLO DI TENUTA 1.78x15.60
	9	4606795	1	501 PLUG	TAPPO
18	10	79021577	K	1K KIT SEE PAGE 9	CORREDO VEDERE PAGINA 9
	(*)			400P FOR OPTIONAL 30 N 70 06 1	PER VARIANTE 30 1070 06 1

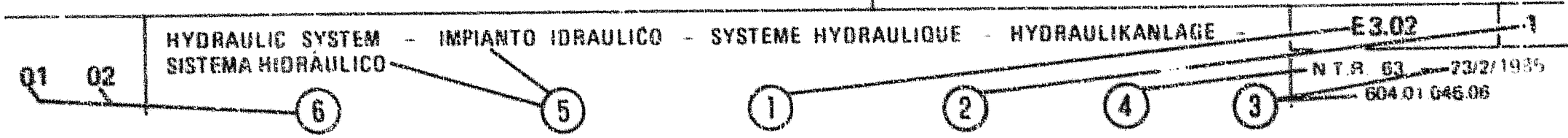

NOTICE

The right is reserved to change the construction or material of any parts where it seems desirable to do so without incurring the obligation of installing such changes on units already delivered.

Additional publications pertaining to this model and to all other products are available through the dealers. Publications are generally available in several languages.

Refer to Service Publications Index form 604.07.040 for all such publications; the index is available from the dealers.

INSTRUCTIONS FOR ORDERING PARTS

At the time this parts catalog was published the listed part numbers were current. It is our policy to constantly improve our machines and therefore, part numbers and design may change.

When ordering parts, verify part numbers through your dealer's microfiche and master numerical index which are up to date with all the latest part numbers.

ORDER PARTS FROM THE DEALER COVERING THE LOCAL TERRITORY

Orders for spare parts must include the following data (see page 4):

- Model, Serial Number, Engine model, Engine serial number, marked on engine block.
- Specify the part number (shown on Spare Parts Catalog list), possibly completed by its description. If parts refer to an assembly which has a model or serial number, also include this information.
- Give post office address, town, county and state where parts are to be shipped.
- Also specify whether material is to be shipped by freight, express or parcel post.
- Confirm all telephone or telegraph orders in writing.

Parts can only be returned to/through the dealer from whom the parts were purchased and must have prior written authorisation. Each return will be treated individually.

Unless claims for shortages or errors are made immediately upon receipt of goods, they will not be considered.

When broken goods are received, a full description of the damage should be made by the carrier agent on the freight bill.

The Factory responsibility is limited, and ceases upon completion of sale conditions provided for each delivery.

AVVERTENZA

La Fabbrica si riserva di modificare la costruzione o il materiale di qualsiasi parte, qualora ciò risulti desiderabile, senza obbligo di apportare tali modifiche sulle unità già consegnate.

Altre pubblicazioni relative a questo modello e a tutti gli altri modelli sono disponibili presso i Concessionari. Le pubblicazioni sono generalmente disponibili in diverse lingue.

Per individuare queste pubblicazioni, fare riferimento all'indice delle pubblicazioni tecniche 604.07.040. Copie dell'indice sono disponibili presso i Concessionari.

ISTRUZIONI PER ORDINARE I RICAMBI

I numeri di ordinazione riportati su questo catalogo sono aggiornati a data di uscita della pubblicazione. È nostra politica migliorare costantemente le macchine e quindi i numeri di ordinazione e le illustrazioni possono non essere più attuali.

Al momento di ordinare i ricambi, verificare i numeri di ordinazione presso il Vostro Concessionario, che dispone delle microfiches e dell'elenco generale dei ricambi aggiornati.

ORDINARE I RICAMBI PRESSO IL CONCESSIONARIO DELLA VOSTRA ZONA

Le ordinazioni di parti di ricambio devono essere corredate delle seguenti indicazioni (vedere pag. 4):

- Modello della macchina, Numero del telaio, Tipo del motore, Numero del motore, stampigliato sul basamento del motore.
- Indicare il numero di ordinazione della parte che si richiede (riportato sugli elenchi del catalogo), possibilmente completato dalla relativa denominazione. Se i ricambi si riferiscono a un complessivo che ha un proprio numero di modello o di serie, precisare anche questi dati.
- Precisare nell'indirizzo l'ufficio postale, la città, la regione e lo stato dove i ricambi devono essere spediti.
- Precisare inoltre le modalità di spedizione del materiale (via mare, via terra, espresso o pacco postale).
- Confermare per iscritto tutti gli ordini anticipati per telefono o telegrafo.

Eventuali restituzioni di parti potranno essere effettuate solamente a/o tramite il Concessionario dal quale le parti furono acquistate e dovranno venire autorizzate in precedenza per iscritto. Ogni restituzione verrà presa in considerazione singolarmente.

I reclami per mancanze e difetti, se non effettuati immediatamente al ricevimento della merce, non verranno presi in considerazione.

In caso di ricevimento di merce danneggiata, una completa descrizione del danno dovrà venire effettuata dall'agente del Corriere trasportatore sul documento di spedizione.

La responsabilità della Fabbrica è limitata e cessa al compimento delle condizioni di vendita previste per ogni singola fornitura.

ATTENTION

L'Usine se réserve le droit de modifier la construction ou le matériau de toute pièce, si cela se révèle nécessaire, sans devoir apporter ces modifications sur les pièces déjà livrées.

D'autres publications concernant ce modèle et tous les autres modèles sont disponibles au près des Concessionnaires. En général, ces publications sont disponibles en plusieurs langues.

Pour trouver ces publications, se référer au catalogue des publications techniques 604.07.040. Des exemplaires du catalogue sont disponibles au près des Concessionnaires.

INSTRUCTIONS POUR LA COMMANDE DES PIÈCES DE RECHANGE

Les numéros de commande indiqués sur ce catalogue sont mis à jour à la date de sortie de la publication. Nous nous efforçons constamment d'améliorer les machines et, par conséquent, les numéros de commande et les illustrations peuvent ne plus être à jour.

Au moment de passer commande des pièces de rechange, contrôler les numéros de commande au près de Votre Concessionnaire, qui dispose des microfiches et de la liste générale des pièces de rechange.

PASSER COMMANDE DE PIÈCES DE RECHANGE CHEZ LE CONCESSIONNAIRE DE VOTRE ZONE:

Les commandes de pièces de rechange doivent comporter les indications suivantes (voir page 4):

- Modèle de la machine, Numéro du châssis, Type du moteur, Numéro du moteur estampillé sur le bâti moteur.
- Indiquer le numéro de commande de la pièce désirée (indiquée sur les listes du catalogue), accompagné si possible de sa désignation. Si les pièces se rapportent à un groupe possédant son propre numéro de modèle ou de série, indiquer aussi ce dernier.
- Indiquer dans l'adresse, le bureau de poste, la ville, la région et le pays où les pièces de rechange doivent être envoyées.
- Indiquer de plus les modalités d'expédition du matériel (par mer, par terre, exprès ou colis postal).
- Confirmer par écrit toutes les commandes anticipées par téléphone ou télégraphe.

En cas de renvois de pièces, ils pourront être effectués seulement à/ou par l'intermédiaire du Concessionnaire chez lequel les pièces ont été achetées et ils devront être autorisés au préalable par écrit. Tout renvoi sera examiné à la fois.

Les réclamations pour manques et défauts, qui ne seront pas présentées immédiatement à la réception de la marchandise, seront rejetées.

En cas de réception de marchandise endommagée, une description complète doit être présentée par l'agent transporteur sur le bordereau d'expédition.

La responsabilité de l'Usine se limite et cesse au moment de l'exécution des conditions de vente prévues pour chaque fourniture.

HINWEIS

Das Herstellerwerk behält sich vor, die Fertigung oder das Material jedes beliebigen Teils abzuändern, falls sie es für wünschenswert hält, ohne dazu verpflichtet zu sein, bereits gelieferte Einheiten entsprechend abzuändern.

Weitere Unterlagen über dieses und sämtliche anderen Modelle stehen bei den Händlern zur Verfügung. Die Unterlagen sind in der Regel auf verschiedenen Sprachen gedruckt.

Zur Suche der erforderlichen Unterlagen ist im Verzeichnis der technischen Veröffentlichungen 634.07 040 nachzuschlagen. Exemplare des Verzeichnisses stehen bei den Händlern zur Verfügung.

ANWEISUNG ZUR BESTELLUNG VON ERSATZTEILEN

Die Bestellnummern des Katalogs werden bei jeder Herausgabe auf den letzten Stand gebracht. Unsere Politik ist eine ständige Verbesserung der Maschinen, so dass Bestellnummern und Abbildungen nicht mehr aktuell sein können.

Beider Bestellung von Ersatzteilen prüfen Sie daher bitte die Bestellnummern bei Ihrem Händler, der über die Mikroarten und über die allgemeine Liste der Ersatzteile samt Änderungen verfügt.

BESTELLEN SIE DIE ERSATZTEILE BEIM HANDLER IHRES GEBIETES

Bei der Bestellung von Ersatzteilen geben sie bitte folgendes an (siehe Seite 4):

- Modell der Maschine, Fahrgestellnummer, Motorbauart, Motornummer, am Kurbelgehäuse eingeschlagen.
- Bestellnummer des gewünschten Teils (nach den Kataloglisten) angeben, möglichst mit der entsprechenden Bezeichnung. Beziehen sich die Ersatzteile auf eine Gruppe mit eigener Modell oder Baureihennummer, so sind auch diese Daten anzugeben.
- In der Adresse sind Postamt, Stadt, Region und Land, nach dem die Ersatzteile zu schicken sind.
- Ausserdem ist die Versandart des Materials anzugeben (See, Land, Express, Postpaket).
- Sämtliche fernmündlich oder telegraphisch erteilten Bestellungen sind schriftlich zu bestätigen.

Eventuelle Rückgaben von Teilen können ausschliesslich an oder durch den Händler erfolgen, bei dem die betreffenden Teile gekauft wurden, und müssen vorher schriftlich genehmigt werden. Jede Rückgabe wird einzeln in Betracht gezogen.

Beanstandungen wegen Mängel oder Fehler werden nur berücksichtigt, wenn sie sofort bei Erhalt der Ware gemacht werden.

Bei Erhalt von beschädigter Ware sollte der Mann des Speditours eine vollständige Beschreibung des Schadens in die Versandpapiere eintragen.

Die Haftung vom Herstellerwerk ist beschränkt und hört nach Erfüllung der für jede einzelne Lieferung vorgesehenen Verkaufsbedingungen auf.

ADVERTENCIA

La Fábrica se reserva el derecho de modificar la construcción o el material de cualquier pieza, si ello resultase procedente, pero sin obligarse a aplicar tales modificaciones a las unidades ya en servicio.

Otras publicaciones referentes a este modelo, lo mismo que a todos los restantes modelos, son disponibles en los Concesionarios. Tales publicaciones, por lo general, son disponibles en diversas lenguas.

Para conocer tales publicaciones consúltese el catálogo de las publicaciones técnicas 604.07.040. Ejemplares de este catálogo obran en los Concesionarios.

COMO SE ENCARGAN LOS RECAMBIOS

Los números de catálogo de las piezas reseñadas en esta publicación están al día hasta la fecha de salida a luz de la misma. Nuestra política estriba en el afán de mejorar constantemente las máquinas, y por lo tanto, los números de catálogo y los grabados a veces puede no sean más efectivos. Con motivo, pues, de ir a encargar piezas de repuesto, verifique los números de catálogo con su Concesionario, el cual dispone de las microfichas y de la lista general de los recambios puesta al día.

ENCARGUENSE LOS RECAMBIOS AL CONCESIONARIO DE SU ZONA

Los encargos de piezas de repuesto tienen que incluir los datos siguientes (véase página 4):

- Modelo de la máquina, Número de fabricación del chasis, Modelo del motor, Número de fabricación del motor, punzonado en el bloque de cilindros.
 - Indicar el número de catálogo de cada pieza encargada - tal cual figura en las listas del catálogo - posiblemente acompañado de la denominación que corresponde.
- Si los recambios pertenecen a un conjunto que posee su propio número de modelo o de serie, indiquense incluso tales datos.
- En la dirección indiquense la oficina de correos, la ciudad, provincia y nación a donde han de remitirse los recambios.
 - Además, indiquense las modalidades de expedición del material: transporte marítimo, terrestre, expreso, o paquete postal.
 - Confirmar per escrito todos los encargos anunciados por teléfono y por cable.

Eventuales devoluciones de piezas podrán hacerse tan sólo a/o por conducto del Concesionario al cual se han comprado las piezas, y deberán ser previamente autorizadas por escrito. Cada devolución se tomará en cuenta según se merece.

Las reclamaciones por faltas o defectos no se tomarán en cuenta, a no ser que vengan efectuadas inmediatamente después de recibir la mercancía.

En caso de que se reciba mercancía que ha sufrido daños, una completa descripción del daño debería ser efectuada por el agente del transportista en el mismo documento de expedición.

la responsabilidad de la Fábrica es limitada y cesa al cumplirse las condiciones de venta provistas para cada aprovisionamiento.

IDENTIFICATION AND VERSION LIST - IDENTIFICAZIONE ED ELENCO DELLE VERSIONI
 IDENTIFICATION ET LISTE DES VERSIONS - KENNZEICHEN UND VERZEICHNIS DER VERSIONEN - IDENTIFICACION Y LISTA DE VERSIONES

MODELS MODELLI MODELES MODELLE MODELOS	ENGINEERING CODE DENOMINAZIONE TECNICA DESIGNATION TECHNIQUE TECHNISCHE BEZEICHNUNG DESIGNACION TECNICA	MODEL SERIAL NUMBER NUMERO DI MATRICOLA DEL MODELLO NUMERO DE SERIE DU MODELE MODELL-SERIENNUMMER NUMERO DE SERIE DEL MODELO		ENGINE MODEL MODELLO DEL MOTORE MODELE DU MOTEUR MOTORBAUMUSTER MODELO DEL MOTOR	NUMERICAL CODE CODICE NUMERICO CODE NUMERIQUE KENNUMMER CÓDIGO NUMERICO
		PRODUCT CODE CODICE PRODOTTO CODE DE PRODUCTION PRODUKT KODEX CODIGO DEL PRODUCTO	UNIT NO. TELAIO NUMERO DE L'UNITE EINHEITS-NR. NUM. DE LA UNIDAD		
FD7	2602.200.001	D7A-1T	FROM SERIAL N 250103 DAL TELAIO N UP TO SERIAL N 250904 FINO AL TELAIO N	8065 04 095	01
			FROM SERIAL N 250905 DAL TELAIO N		

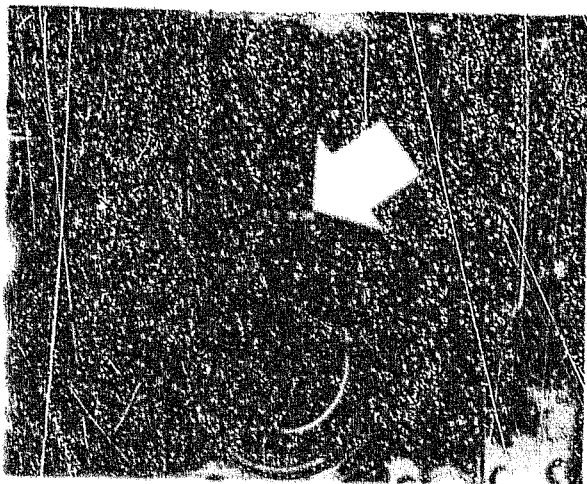

Machine serial number location
Posizione del numero di matricola della macchina
Emplacement du numéro de série de la machine
Ort der Seriennummer der Maschine
Ubicación del número de serie de la maquina

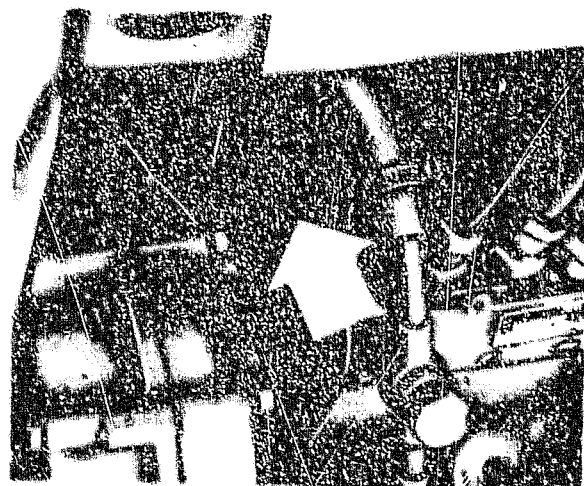

Engine serial number location
Posizione del numero di matricola del motore
Emplacement du numéro de série du moteur
Ort der Seriennummer des Motors
Ubicación del número de serie del motor

RECORD YOUR SERIAL NUMBERS BELOW
REGISTRARE I VOSTRI NUMERI DI MATRICOLA QUI SOTTO
ENREGISTREZ VOS NUMEROS DE SERIE CI-DESSOUS
UNTEN SERIENNUMMER VERMERKEN
ANOTE AQUI LOS NUMEROS DE SERIE

MACHINE SERIAL NUMBER - MATRICOLA DELLA MACCHINA
NUMERO DE SERIE DE LA MACHINE - SERIENNUMMER DER MASCHINE
NUMERO DE SERIE DE LA MAQUINA

ENGINE SERIAL NUMBER - MATRICOLA MOTORE
NUMERO DE SERIE DU MOTEUR - SERIENNUMMER DES MOTORS
NUMERO DE SERIE DEL MOTOR

Availability of optional equipments and terms for their delivery should be checked with your Dealer .

La disponibilità delle varianti e relativi tempi di consegna devono essere richiesti al concessionario di zona .

Pour connaître si les variantes sont disponibles et les termes de livraison s'adresser au concessionnaire de votre zone .

Verfügbarkeit der Varianten und Liefertermine werden mitgeteilt von Ihrem Werkshändler .

Pida a su concesionario de zona si las variantes son disponibles y cuáles son los plazos de entrega .

OPTIONAL EQUIPMENT - ELENCO DELLE VARIANTI
LISTE DES VARIANTES - LISTE DER VARIATEN - LISTA DE VARIANTES

CODE - CODICE - CODE KENNUMMER - CODICO	SGR.	DESCRIPTION - DENOMINAZIONE DESIGNATION - BENENNUNG - DENOMINACIONES
76016158 C 3212 VII-1990	L1.30/1	FANA VERSION - ALLESTIMENTO FANA - VARIANTE POUR AMERIQUE DU NORD - VERSION FUER NORDAMERICA - VERSION PARA NORTEAMERICA
30.0020.16.1	L3.10.1	OPERATOR COMPARTMENT SOUND INSULATION - INSONORIZZAZIONE POSTO GUIDA - INSONORIZATION DU POSTE DE CONDUITE - INNER SCHALLDAEM- PFUNG FUER FAHRERSTAND - INSONORIZACION DEL PUESTO DE CONDU- CION
30.0022.31.1	A2.22 A4.09.1 L1.01	OUTSIDE SOUND ABATMENT - INSONORIZZAZIONE ESTERNA - INSONORI- SATION EXTERIEURE - AUSSERE SCHALLDAEMPfung - INSONORIZA- CION EXTERNA
30.0090.10.1	E3.02.1 E3.31.1	MAIN CONTROL VALVE FOURTH SECTION SWITCH - DEVIATORE PER 4 CO MANDO-DEVIATEUR DE 4 ^{em} COMMAND - WECHSELSCHALTUENTIL FUER 4 STEUERVENTIL - SELECTOR PARA IV MANDO
30.0127.02.1	E3.02.9 E3.02.10 E3.10.7 E3.13.3 E3.32.2 E3.32.3	ALL HYDRAULIC VERSION - ALLESTIMENTO ALL HYDRAULICO - EQUIP MENT ALL HYDRAULIC - AUSRUSTUNG FUR ALL HYDRAULIC - TIPO ALL HYDRAULIC
30.0191.21.1	A2.22.1 A2.23.1 A2.23.2	OIL BATH AIR FILTER - FILTRO ARIA A BAGNO D'OLIO - FILTRE A AIR A BAIN D'HUIL - OELBADLUFTFILTER - FILTRO DE AIRE EN BANO DE ACEI TE

30.0192.14.1	A2.22/2	AIR CLENAER EXTENSION - PROLUNGA FILTRO ARIA - RALLONGE DE FILTRE A AIR - LUFTFILTER VERLAIENGERUNG - EXTENSION DEL FILTRO DE AIRE
30.0289.02.1	B2.00 - B2.01/1 - B2.01/1A	MOUNTING FOR POWER TAKE-OFF - PREDISPOSIZIONE PRESA DI FORZA - FIXATIONS POUR PRISE DE FORCE - BEFESTIGUNGS AUGEN FUER ZAPI WELLE - ANCLAJES PARA TOMA DE FUERZA
30.0405.02.1	E3.02/11 - E3.10 - E3.10/9 - E3.13/5 - E3.32/8 - H1.01/2	STRAIGHT MOLDBOARD (HS) "8B" ON "FD7" - LAMA DIRITTA (HS) "8B" SU "FD7" - LAME HS DROITE "8B" SUR "FD7" - SCHILD HS GERADE "8B" AUF "FD7" - HOJA HS RECTA "8B" SOBRE "FD7"
30.0405.03.1	E3.02/11 - E3.10/4 - E3.10/8 - E3.13/4 - E3.32/7 - H1.01/2	SEMI-U MOLDBOARD (HSU) "8B" ON "FD7" - LAMA SEMI U (HSU) "8B" SU "FD7" - LAME DEMI-U "8B" SUR "FD7" - SEMI U SCHILD "8B" AUF "FD7" - HOJA EN FORMA DE SEMI-U "8B" SOBRE "FD7"
30.0505.16.1	D3.40 A	LUBRICATED TRACK CHAIN - CATENARIA LUBRIFICATA - CHAINE ASSEMBLEE - LUBRIFICE GESCHMIERTE - CADENA ENGRASADA
30.0530.08.1 C 2869 - Tel.n. 251325	D3.40 1	TRACK SHOES 500 - SOULE 500 - TUILES DE 500 - BODENPLATTEN 500 - ZAPATAS 500
30.0530.16.1 D 2869 Tel.n. 251326	D3.40 A	TRACK SHOES 500 - SUOLE 500 - TUILES DE 500 - BODENPLATTEN 500 - ZAPATAS 500

30.0563.16.1	L3.11/1	TRACK FRAME ROLLER GUARDS - RIPARI RUOTE CARRELLO - CARTER DE ROUES DE CHARIOT - ABDECKUNGEN FUER KETTENROLLEN - PROTECCIONES RUEDA DEL CARRO
30.0570.18.1	E1.02 - L1.03 - L1.04	CAB - CABINA - CABINE - FAHRERHAUS - CABINA
30.0571.04.1	L1.03/1	ROPS CAB WHIT LAMINATED FRONT GLASS - CABINA SICUREZZA CON VETRO STRATRIFICATO - CABINE DE SECURITE AVEC GLACE AVANT FEUL LETEE ROPS KABINE MIT FRONTSCHIEBE AUS VERBUNDGLASS - CABINA ANTIVUELCO CON CRISTAL ANTERIOR ESTRATIFICADO
30.0753.09.1 C3447 → Tel. n. 251910	F3.01 - F3.03/1	ALTERNATOR 55A - ALTERNATORE 55A - ALTERNATEUR 55A - DREHSTROMLICHT MASCHINE 55A - ALTERNADOR 55A
30.0758.02.1 C 2837 --Tel.n. 251332	F4.01/1 - F4.05	REAR SPOT LAMP - PROIETTORE POSTERIORE - PHARE ARRIERE - HINTERER SCHEINWERFER - FARO POSTERIOR
30.0758.08.1 D 2837 Tel.n. 251333 --	F4.01/1A	REAR SPOT LAMP - FRIETTORE POSTERIORE - PHARE ARRIERE - HINTERER SCHINWERFER - FARO POSTERIOR
30.0759.11.1	F5.01/1 - F5.01/1A	BACK UP ALARM PROVISION - PREDISPOSIZIONE BACK UP ALARM - BACK UP ALARM SANS AVVETISSEU - WARN RUECK WAERTS OHNE HUPE - BACK UP ALARM SIN BOCINA
30.0760.11.1	F5.01/1 - F5.01/1A	BACK UP ALARM - AVVISTATORE ACUSTICO DI R.M. - BACK UP ALARM - WARNEIN RICHTUNG RUECKWAERTS - BACK UP ALARM

30.0765.03.1 C 2837 → Tel.n. 251332	F4.01/2	HEAD LAMPS FOR ROPS STRUCTURE - PRIETTORI PER STRUTTURA ROPS - PROJECTEURS POUR LA STRUCTURE DE PROTECTION ROPS - SCHEINWERFERS FUER ROPS DACH - PROYECTORES PARA ESTRUCTURA ROPS
30.0765.05.1 D 2837 Tel.n. 251333 --	F4.01/2A	HEAD LAMPS FOR ROPS STRUCTURE - PROIETTORI PER STRUTTURA ROPS - PROJECTEURS POUR LA STRUCTURE DE PROTECTION ROPS - SCHEINWERFERS FUER ROPS DACH - PROYECTORES PARA ESTRUCTURA ROPS
30.0780.01.1	B5.01	DIAGNOSTIC SYSTEM - DIAGNOSTICA CENTRALIZZATA - DIAGNOSTIC CENTRALISE - ZENTRALE FEHLERSUCHANLAGE - DIAGNOSTICO CENTAL
30.0805.12.1	E2.16	POWER TAKE OFF - PRESA DI FORZA - PRISE DE FORCE - ZAPFWELLE - TOMA DE FUERZA
30.0836.12.1	L1.01	PERFORATED SIDE PANELS - FIANCHETTI FORATI - TABLIERS LATERALS PERCES GELOCHTE SINTENTEILE - COSTADOS LATERALES AGUJEREADOS
30.0843.10.1	L1.01	INSTRUMENT PANEL SAFETY COVER - COPERCHI CRUSCOTTO ANTIVANDALO - CAPOT DE SECURITE POUR TABLEAU DE BORD - SICHERHEITS DECKEL FUER SCHALTBRETT -- TAPAS ANTIVANDALISMO DEL TABLERO
30.0852.05.1	L6.01/1 - L6.04	SUSPENSION SEAT - SEDILE CON SOSPENSIONE ELASTICA - SIEGE SUR SUSPENSIONS - GEFERDERTER SITZ - ASIENTO DE SUSPENSION ELASTICA
30.0853.01.1	L6.01/2	SUSPENSION SEAT - SEDILE CON SOSPENSIONE ELASTICA - SIEGE SUR SUSPENSIONS - GEFERDERTER SITZ - ASIENTO DE SUSPENSION ELASTICA
30.0876.25.1	L3.08	ROPS CANOPY - STRUTTURA DI PROTEZIONE ROPS - STRUCTURE DE PROTECTION ROPS - ROPS DACH - TOLDO ROPS

30.0890.07.1	D1.03/1	TOWING DEVICE - ORGANO DI TRAINO - ORGANE D'ATTELAGE - ANH. AENGER KUPPLUNG - BARRA DE ARRASTRE
30.0920.14.1	E3.02/2 - E3.05 - E3.10/2 - E3.32/1	RIPPER PD7 - SCARIFICATORE PF7 - SCARIFICATEUR PD7 - AUFREIS SER PD7 - RIPPER PD7
30.0935.08.1	E3.15	TOOTH - UTENSILE - DENT - REISSZAHN - DIENTE
30.0978.23.1	L4.10	DECALS IN ITALIAN - TARGHE IN LINGUA ITALIANA - DECALCOMANIES EN ITALIEN - ABZIEHBILDER IN ITALIAN - CALCOMANIAS EN ITALIANO
30.0980.42.1	L4.10	DECALS IN ENGLISH - TARGHE IN LINGUA INGLESE - DECALCOMANIES EN ENGLISH - ABZIEHBILDER IN ENGLISH - CALCOMANIAS EN INGLIS
30.0981.21.1	L4.10	DECALS IN GERMAN - TARGHE IN LINGUA TEDESCA - DECALCOMANIES EN ALLEMANDE - ABZIEHBILDER IN DUELSCHER SPRACHE - CALCOMA NIAS EN ALEMAN
30.0982.20.1	L4.10	DECALS IN FRENCH - TARGHE IN LINGUA FRANCESE - DECALCOMANIES EN FRANCAIS - ABZIEHBILDER IN FRANZOESISCH - CALCOMANIAS EN FRANCES
30.0986.18.1	L4.10	DECALS IN PORTUGUESE - TARGHE IN LINGUA PORTOGHESE - DECALCO MANIES EN PORTUGAIS - ABZIEHBILDER IN PORTUGIESCHER - CALCOMA NIAS IN PORTUGUES
30.0987.18.1	L4.10	DECALS IN SPANISH - TARGHE IN LINGUA SPAGNOLA - DECALCOMANIES EN ESPANOL - ABZIEHBILDER IN SPANISHER - CALCOMANIAS EN SPANOL

30.0993.02.1	H1.04	FUEL TRANSFER PUMP - POMPA TRAVASO COMBUSTIBILE - POMPE DE TRANSVASEMENT DE COMBUSTIBLE - UMGIESSPUMPE FUER KRAFTSTOFF BOMBA DE REPOSTADO DE COMBUSTIBLE
30.0995.09.1	H1.01	TOOLS - ATTREZZI - OUTILS - WERKZEUGE - HERRAMIENTAS
30.0995.12.1	H1.01/1	TOOLS - ATTREZZI - OUTILS - WERKZEUGE - HERRAMIENTAS
30.1001.06.1	E3.10/1	FRAME - ARNONE - ETRIER - U RAHMEN - AERON
30.1003.02.1	E3.10	FRAME - ARNONE - ETRIER - U RAHMEN - AERON
30.1011.05.1	E3.10/3	ADJUSTABLE STRUTS - FORCELLE MECCANICHE - BIELLES REGLABLES - EINSTELLBARE STANGEN - BIELAS REGULABLES
30.1015.06.1	E3.13	ANGLING MOLDBOARD - LAMA HA (ANGOLABILE) - LAME D'ANGLEDOZER - SCHWENKENSCHILD - HOJA ANGLEDOZER
30.1016.01.1	E3.13.1	MOLDBOARD - LAMA - LAME - SCHILD - HOJA
30.1030.02.1	E3.02.5 E3.32.2	ANGLE CYLINDER AND PIPING - CILINDRI ANGOLAZIONE E TUBAZIONI - VERNIS DE BIAIS ET TUYAUTERIES - SCHWENKZYLINDER UND LEITUNGEN - GATOS DE PIVOTAMIENTO Y TUBERIAS
30.1040.05.1	E3.10.5	PUSH BEAMS AND BRACES - BRACCI E TIRANTI - BRAS ET TIRANTS - SCHUBHOLMEN UND STREBEN - BRAZOS Y TIRANTES
30.1056.04.1	E3.13.2	HS MOLD BOARD (STRAIGHT) - LAMA HS (DIRITTA) - LAME HS (DROITE) - SCHILD HS (GERADE) - HOJA HS (RECTA)

DESIGNAZIONE BASE	BASIC DESIGNATION	DESIGNATIONS-BASES	GRUNDBEZEICHNUNGEN	DENOMINACIONES BASE
16T	TACHIMETRO	SPEEDOMETER	TACHOMETER	VELOCIMETRO
16V	VARIATORE DI ANTICIPO	ADVANCE VARIATOR	SPRITZZEITVERSTELLER	VARIADOR DE ADELANTO
166	IMPIANTO SPECIALE RAFFREDDAM	SPECIAL COOLING SYSTEM	SONDERKUEHLSYSTEM	
167	PURIFICATORE CATALITICO			
17A	ALBERO AD ECCENTRICI	CAMSHAFT	EXZENTERWELLE	ARBOL DE LEVAS
171	INCASTELLATURA	FRAME	GERUEST	BASTIDOR
17R	RACCORDO A 4 VIE	FOUR-WAY FITTING	ROHRKREUZSTUECK	RACOR DE 4 BOCAS
17V	VALVOLA PER FRENO	BRAKE VALVE	VENTIL FUER BREMSE	VALVULA PARA FRENO
173	REGOLATORE RAFFRED. RADIATORE	RADIATOR SHUTTER		
174	GRIGLIA ANTISABBIA	SAND SCREEN	SANDSCHUTZGITTER	
176	VENTILATORE ASPIRANTE	SUCTION FAN	SAUGLUEFTER	
178	VENTILATORE A PALE REVERSIBILI	REVERSIBLE FAN	LUEFTER VERSTELLBAREN FLUEGELN	VENTILADOR DE ASPAS REVERSIBLE
18A	ALBERO MOTORE	CRANKSHAFT	KURBELWELLE	CIGUENAL
18L	LAMIERINO DI MASSA	GROUND PLATE	MASSESCHLUSS	FLEJE DE MASA
18T	TAGLIENTE	CUTTING EDGE	SCHNEIDMESSER	CUCHILLO
107	EIETTORE POLVERE FILTRO ARIA	EXHAUST ASPIRATED AIR CLEANER	LUFTFILTER MIT STAUBABZUG	
19A	ALBERO SMOCCATO	ARTICULATED SHAFT	GELENKWELLE	ARBOL ARTICULADO
19T	TAGLIENTE LATERALE	END BIT	ECKMESSER	CUCHILLO LATERAL
19V	VASCHETTA	PAN	GEFASS	CUBA
190	FILTRO ARIA A SECCO	DRY AIR CLEANER	TROCKENLUFTFILTER	
192	PROLUNGA FILTRO ARIA	PRECLEANER EXTENSION	FILTER VERLANGERUNG	
20B	BASAMENTO MOTORE	CRANKCASE	KURBELGEKAEUSE	BLOQUE CILINDRICO
20C	CALOTTA	CAP	KAPPE	CASQUETE
20D	DEFLETTORE	DEFLECTOR	LEITBLECH	DEFLECTOR
20E	ELEMENTO FILTRANTE	FILTERING ELEMENT	FILTREINSATZ	FILTRO
20G	GALLEGGIANTE	FLOAT	SCHWIMMER	FLOTANTE
20I	IMBUTO	FUNNEL	TRICHTER	EMBUDO
20L	LAMIERINO PARAOLIO	OIL SHIELD	OELFANGSCHEIBE	REYNEDOR DE ACEITE
20M	MANIGLIA	HANDLE	GRIFF	MANIJA
20N	NASTRO	BAND	BAND	CINTA
20P	PALIGLIONE	ROOF PANEL	KABINENDACH	TECHO
20R	RACCORDO	FITTING	STUTZEN	RACOR
20S	SATELLITE	PLANETARY GEAR	PLANETENRAD	PINON SATELITE
20T	TAMBURO	DRUM	TROMMEL	TAMBOR
20U	UGELLO	JET	GICLUR	INYECTOR
204	AVVIAMENTO A FREDDO	COLD WEATHER STARTING AID	KALTSTART-EINRICHTUNG	DISPOSITIVO TERMOSTATER
21A	ALETTA RADIATORE	RADIATOR FIN	KUEHLERRIPPE	ALETA RADIADOR
21C	CALOTTA SFERICA	SPHERICAL CAP	KUGELKAPPE	TAPA SFERICA
21G	GAMBA DI APPOGGIO	SUPPORT LEG	STUETZBEIN	PATA DE APOYO

DESIGNAZIONE BASE	BASIC DESIGNATION	DESIGNATIONS-BASES	GRUNDBEZEICHNUNGEN	DENOMINACIONES BASE	
21N	NASTRO DI GOMMA	RUBBER TAPE	RUBAN CAOUTCHOUC	GUMMIBAND	CINTA DE CAUCHO
21R	RACCORDO ORIENTABILE	BAND UNION	RACCORD REGLABLE	RINGSTUTZEN	RACOR ORIENTABLE
21T	TAMBURO DI REAZIONE	REACTION DRUM	TAMBOUR DE REAC-	REAKTIONSTROMMEL	PLAKETA DE REAC-
21T			TION		CION
21V	VERRIGELLO	WINCH	TREUIL	SERWINDE	TORNO
215	ZAVORRA ANTERIORE	FRONT COUNTERWEIGHT	CONTREPOIDS ANTERIEUR	KONTERGEWICHT VORNE	CONTRAPESO ANTERIOR
21B	ZAVORRA SUPPLEMENTARE	ADDITIONAL COUNTERWEIGHT		ZUSATZKONTERGEWICHT	
223	GAMBO	STEM	TIGE	SCHAFT	VASTAGO
220	NASTRO DI FISSAGGIO	SECURING STRAP	RUBAN DE FIXATION	SPANNBAND	TIRA DE FIJACION
225	SCALETTA	LADDER	ECHELLE	LEITER	ESCALERILLA
221	ZAVORRA POSTERIORE	REAR COUNTERWEIGHT		KONTERGEWICHT HINTER	
222	ZAVORRA E GANCIO TRAINO	COUNTERWEIGHT AND DRAWBAR		KONTERGEWICHT UND ZUGHAKEN	
23A	ALBERO TRASMISSIONE	DRIVE SHAFT	ARBRE DE TRANSMISSION	UEBERTRAGUNGSWELLE	ARBOL DE TRANSMISION
23B	BATTENTE DELLA PORTA	DOOR PANEL	FEUILLURE DE PORTE	TUERFLUEGEL	NOJA DE PUERTA
230	GAMBO DEL PEDALE	PEDAL STEM	TIGE DE PEDALE	FLUSSHEBELSCHAFT	VASTAGO DE PEDAL
23M	MANIGLIA DI APPIGLIO	GRAB HANDLE	POIGNEE	HALTEGRIFF	ASA
23P	PALETTA VENTILATORE	BLADE FAN	AUBE	LUEFTERFLUEGEL	ASPA
23R	HALLA DI SPINTA	THRUST PLATE	BAGUE D'ARRET	DRUCKSCHEIBE	RANGUA
235	SCALPELLO	CHISEL	BURIN	MEISSEL	CORTAFRIOS
24B	BASSETTA	JUNCTION BLOCK	PLAQUE DE JONCTION	SOCKEL	PLACA DE EMPALME
241	IMBOTTITURA	PADDING	REMBOURRAGE	POLSTERUNG	EMBUTIDO
24W	NASTRO FRENO	BRAKE BAND	BANDE DE FREIN	BREMSBAND	CINTA DE FRENO
240	OROLOGIO	CLOCK	MONTRE	UHR	RELOJ
25A	ALTERNATORE	ALTERNATOR	ALTERNATEUR	DREHSTROMLICHTMASCHINE	ALTERNADOR
25B	BATTERIA	BATTERY	BATTERIE	BATTERIE	BATERIA
25C	CALZATOIA	CHOCK	CALE DE ROUE	HEMMSCHUH	CALZO DE RUEDA
25D	DENTE RIPPER	RIPPER SHANK	DENT DE RIPPER	AUFREISSERZAHN	DIENTE DE RIPPER
25F	FARFALLA	THROTTLE	PAPILLON	GRÖSSELKLAPPE	MARIPOSA
25G	GANASCIA FRENI	BRAKE SHOE	MACHOIRE DE FREINS	BREMSBACKE	PINZA DE FRENOS
251	IMPUGNATURA	HANDGRIP	POIGNEE	GRIFF	EMPUÑADURA
25N	NASTRO ADESIVO	ADHESIVE TAPE	CHATTERTON ADHESIF	KLEBEBAND	CINTA ADHESIVA
25P	PANNELLO	PANEL	PANNEAU	VERKLEIBUNG	PANEL
25R	RADIATORE	RADIATOR	RADIATOR	RUHRLER	RADIATOR
25S	SCAMBIATORE DI CALORE	HEAT EXCHANGER	ECHANGEUR DE TEMPERATURE	WAERMETAUSCHER	CAMBIADOR DE CALOR
25T	TAMPONE DI GOMMA	RUBBER PAD	TAMPON CAOUTCHOUC	GUMMIPUFFER	TOPE DE GOMA
25V	VED.	SEE...	VOIR	SIENE	VEASE
251	BENNA SCAVO FOSSI	DITCH DIGGING BUCKET	GODET CREUSAGE FOSSES	GRABENLOEFFEL	CUCHARA LIMPIA DECLIVIOS
252	BENNA PULIZIA FOSSI	DITCH CLEANING BUCKET	BENNE DE TALUTAGE	GRABENRAEUMLOEFFEL	ELEVADOR DE
26A	ALZACRISTALLO	WINDOW REGULATOR	LEVE-GLACE	KURBELAPPARAT	CRISTAL

DESIGNAZIONE BASE	BASIC DESIGNATION	DESIGNATIONS BASES	GRUNDBEZEICHNUNGEN	DENOMINACIONES BASE	
26D	DEPRESSORE	VACUUM PUMP	DEPRESSEUR	VAKUUMPUMPE	BOMBA DE VACIO
26G	GANASCIA	JAW	MACHOIRE	BACKE	TENAZA
26N	NERVATURA	RIB	NERVURE	RIPPE	NERVIO
25T	TAMPONE	WICK	TAMPON	PUFFER	TOPE DE GOMA
26V	VED. TABELLA	SEE TABLE	VOIR TABLEAU	SIEHE TABELLE	VEASE LA TABLA...
266	SPAZZOLATRICE				
27D	DEVIATORE	DIVERTER VALVE	DEVIATEUR	VERTEILER	VALVULA DE DESVIO
27P	FARALUCE	LIGHT SCREEN	ECRAN ANTI-LUMIERE	LICHTSCHIRM	PANTALLA
28N	NIPPLU	NIPPLE	RACCORD	ANSCHLUSS	NIPLE
28O	OSSATURA	STRUCTURE	OSSATURE	RAHMENWERK	ARMAZON
28P	PARABOLA	REFLECTOR	REFLECTEUR	PARABOLSPIEGEL	REFLECTOR
28R	REGOLATORE DI VELOCITÀ	SPEED GOVERNOR	REGULATEUR DE VITESSE	DREHZAHLEGLER	REGULADOR DE VELOCIDAD
28R					
281	RUOTISMI PER TRATTORE LENTO	GEARS FOR SLOW TRACTOR	PIGNONS POUR TRACTEUR LENT	LANGSAMGANG ANTRIEBSRAEDER	
284	RUOTISMI PER I E II VELOCE	I AND II FAST SPEED GEARS	PIGNONS DE I ET II VITESSE	I-II GANG ANTRIEBSRAEDER	
285	RUOTISMI PER VELOCITÀ COMPATTE	NARROW INCREMENT SPEED GEARS	PIGNONS POUR VITESSE COMPACTES	KRIECHGANG ANTRIEBSRAEDER	
286	RUOTISMI PER TRATTORE VELOCE	GEARS FOR FAST TRACTOR	PIGNONS POUR TRACTEUR RAPIDE	SCHNELLGANG ANTRIEBSRAEDER	INGRANAJES PARA TRACTOR RAPIDO
29F	FASCIA	BAND	BANDE	ITALTBAND	FAJA
29I	INDICATORE DI DIREZIONE	DIRECTION INDICATOR	INDICATEUR DE DIRECTION	RICHTUNGSANZEIGER	INDICADOR DE DIRECCION
29I					
29P	PARASASSI	STONEGUARD	CHASSE-PIERRES	STEINSCHLAG-SCHUETZER	GUARDAPIEDRAS
29P					
29R	REGOLATORE DI FREQUENZA	FREQUENCY REGULATOR	REGULATEUR DE FREQUENCE	FREQUENZREGLER	REGULADOR DE FRECUENCIA
29R					
294	RITARDATORE IDRAULICO	RETARDER AND CONTROL			
30A	ACCUMULATORE PER FRENO	BRAKE ACCUMULATOR	ACCUMULATEUR DE FREINS	BREMSSPEICHER	ACUMULADOR DE FRENOS
30A					
30C	CAMBIO VELOCITÀ	TRANSMISSION	BOITE DE VITESSE	WECHSELGETRIEBE	CAMBIO
30C	DEVIAGUIDASGANCIO E DEVIOLUCI	SWITCH UNIT	COMBINA TEUR AU VOLANT	LENKSTOCK-UMSCHALTER	INTERRUPTOR CONMUTADOR
30E	ELETTROMAGNETE	SOLENOID	SOLENOIDE	ELEKTROMAGNET	ELECTROMAN
30G	GANCIO	HOOK	CROCHET	HAKEN	GANCHO
30I	COMANDO INDICATORE LIVELLO	LEVEL INDICATOR SENDING UNIT	COMMANDE DE JAUGE DE NIVEAU	STANDGEBER	MANDO DEL INDICADOR DE NIVEL
30I					
30L	LAMPADA	LAMP	LAMPE	GLUEHBIRNE	LAMPARA
30M	MANICOTTO	SLEEVE	MANCHON	MUFFE	MANGUITO
30P	PARACOLPI DI GOMMA	RUBBER BUFFER	PARE CHOC	GUMMIPUFFER	TOPE DE GOMA
30P					
30R	REGOLATORE CENTRIFUGO	GOVERNOR	REGULATEUR CENTRIFUGE	FLIEHKRAFTREGLER	REGULADOR CENTRIFUGO
30R					

ITEM	PART N.	GRID	ITEM	PART N.	GRID	ITEM	PART N.	GRID	ITEM	PART N.	GRID	ITEM	PART N.	GRID
19	14282970	1-H7	15	14330260	2-M10	14	14457180	2-O8	16	14459080	2-L15	13	14464280	2-I6
22	14304321	2-S13	21	14330260	2-R8	14	14457180	2-O3	17	14459180	2-L15	19	14464380	2-N14
9	14305620	1-M2	9	14437985	1-I2	9	14457180	2-P3	14	14459180	2-P7	14	14464380	2-N16
16	14323811	1-H4	9	14438385	2-I5	7	14457280	2-H12	20	14460380	2-M12	8	14464980	2-P9
17	14323911	1-H4	22	14438385	2-I4	6	14457280	2-H13	20	14460380	2-M11	9	14465180	2-N5
20	14323911	1-H5	38	14452880	1-N6	11	14457280	2-H14	4	14462880	2-O12	15	14465180	2-R13
16	14323911	1-H6	15	14452980	2-L15	17	14457280	2-M8	15	14462881	1-P4	7	14465380	2-N3
20	14323911	1-H7	13	14452980	2-O8	4	14457280	2-O16	12	14462980	1-O12	5	14465380	2-N4
18	14324211	1-H4	13	14452980	2-O3	4	14457280	2-O15	12	14462980	1-R4	16	14465480	2-R13
17	14324211	1-H6	8	14452980	2-P3	5	14457280	2-O7	12	14462980	1-R12	8	14465480	2-R16
12	14324811	2-M10	16	14452980	2-P7	7	14457280	2-O4	12	14462980	1-S2	7	14465480	2-S15
11	14324911	1-O2	25	14452980	2-R10	5	14457280	2-O2	12	14462980	1-T10	10	14465480	2-S14
13	14324911	2-M10	6	14452980	2-S10	5	14457280	2-P4	15	14462980	2-O8	9	14465780	2-R16
10	14325011	1-P8	29	14453180	2-L5	12	14457281	1-O7	15	14462980	2-O3	8	14465780	2-S15
10	14325011	1-P9	22	14453580	1-H7	8	14457380	2-S10	10	14462980	2-P3	11	14465780	2-S14
14	14325011	2-M10	4	14453981	1-H7	8	14457480	2-M17	6	14463080	2-O11	10	14466080	2-I4
15	14325211	1-P2	21	14453981	1-L16	12	14457480	2-P7	30	14463180	2-L5	10	14466080	2-R15
22	14325601	1-H10	10	14454381	2-T3	16	14457481	1-O10	15	14463180	2-P7	11	14466380	2-R15
26	14326050	1-L9	23	14456980	2-M9	16	14457481	1-O9	9	14463280	2-P6	10	14466580	2-R17
6	14326213	2-H9	7	14456980	2-S10	26	14457580	2-R11	28	14463280	2-R11	16	14466580	1-I2
16	14327101	2-M15	5	14457080	2-H13	17	14457581	1-O10	15	14463281	1-P4	16	14466780	2-S12
10	14328101	1-H13	10	14457080	2-H14	17	14457581	1-O9	4	14463480	2-M13	16	14466780	2-S11
22	14328101	1-H14	5	14457080	2-N3	27	14457680	2-R11	17	14463480	2-N14	11	14466880	2-I10
11	14328101	1-I16	3	14457080	2-N4	5	14457681	1-O11	18	14463780	2-N14	11	14466880	2-I8
40	14328301	1-I13	12	14457180	1-Q14	7	14457781	2-H9	23	14463880	1-H10	4	14466880	2-N12
40	14328301	1-I11	13	14457180	1-Q12	13	14458280	2-P7	25	14463880	1-O9	13	14466880	2-R5
19	14328501	1-H4	12	14457180	1-R2	6	14458281	1-P10	25	14463880	1-R6	10	14466880	2-R17
19	14328501	1-H6	13	14457180	1-R4	9	14458480	2-S14	25	14463880	1-S13	14	14467180	2-I6
14	14328501	1-O10	12	14457180	1-R10	6	14458580	1-P17	25	14463880	1-T4	11	14467680	2-I4
15	14328701	1-O10	13	14457180	1-R12	6	14458580	1-O5	25	14463880	2-H4	4	14467781	2-L12
11	14329701	2-I6	12	14457180	1-S4	6	14458580	1-R16	47	14463880	2-H8	14	14468280	2-R5
20	14329901	1-H4	13	14457180	1-S2	6	14458580	1-S8	9	14463880	2-S14	12	14470980	2-I10
19	14329901	1-H6	12	14457180	1-T8	6	14458580	1-T14	13	14463980	2-N16	13	14471480	2-I8
14	14330260	1-P16	13	14457180	1-T10	19	14458680	1-M13	6	14464080	2-N3	1	14471480	3-H9
3	14330260	2-H11	7	14457180	2-M17	12	14458780	2-I6	4	14464080	2-N4	13	14472080	2-I10

ITEM	PART N.	GRID	ITEM	PART N.	GRID	ITEM	PART N.	GRID	ITEM	PART N.	GRID	ITEM	PART N.	GRID
13	12646821	3-H2	2	13297921	1-N2	12	13517311	1-I9	9	14142490	2-T6	16	14233030	2-M2
5	12646821	3-H3	3	13301717	3-I11	13	13517530	1-H7	9	14142490	2-T14	14	14233430	2-I10
12	12646821	3-H17	15	13398376	2-M15	10	13517530	1-M12	10	14142690	2-T6	17	14233430	2-M2
18	12646821	3-I16	11	13400575	1-I10	11	13517630	1-M16	6	14142690	2-T16	8	14233630	2-I10
11	12646821	3-I13	11	13400575	1-I9	11	13517720	1-H11	8	14142690	3-H2	8	14233630	2-I8
21	12646821	3-I6	7	13401176	2-L6	11	13517720	1-H12	16	14157470	2-M8	10	14233630	2-I6
5	12646821	3-L7	3	13401176	2-L7	29	13517821	1-H10	16	14158470	3-I13	15	14237930	2-R12
10	12646821	3-L11	3	13401176	2-M13	12	13540921	1-H11	33	14159670	1-O16	8	14238130	2-N5
7	12646821	3-L12	12	13401675	1-I5	6	13543620	2-N11	15	14161770	3-H17	3	14238131	2-N3
9	12646821	3-L13	1	13407211	2-I11	8	13543621	2-N11	13	14161970	1-N7	2	14238131	2-N4
13	12646821	3-L14	4	13407211	2-M6	11	13547521	2-H17	20	14161970	2-R8	9	14254930	2-I10
8	12646821	3-L16	15	13407211	2-M2	12	13550401	2-H17	24	14161970	2-R10	9	14254930	2-I8
9	12646821	3-L17	14	13407211	2-N12	6	13550421	2-O10	8	14162270	2-R4	17	14258037	3-H17
5	12646821	3-M17	8	13407211	2-P8	6	13550421	2-O9	11	14163170	2-L13	10	14271530	2-I10
13	12646821	3-M15	14	13407211	2-P10	8	13555530	2-I6	13	14163170	2-L14	10	14271530	2-I8
7	12646821	3-M14	15	13407211	2-P11	10	13566637	2-L10	16	14163170	3-H17	3	14271530	2-P14
15	12646921	1-O6	4	13407211	2-P12	2	13605711	3-M9	12	14163270	1-L3	15	14272030	2-S12
16	12646921	2-N14	2	13407211	2-P14	2	13605711	3-M6	8	14163270	1-L5	15	14272030	2-S11
13	12646921	3-H17	22	13407211	2-P15	9	13739811	1-F9	20	14163270	2-R3	4	14272031	2-M7
31	12646921	3-I12	14	13407211	2-Q17	9	13748610	1-P8	36	14163370	1-N6	9	14274430	2-L11
15	12646921	3-L9	36	13407211	2-Q14	9	13748710	1-P3	17	14163470	2-T13	3	14274430	2-L12
6	12646921	3-M17	26	13407211	2-Q11	35	13824611	1-N6	14	14164070	2-R12	5	14274530	2-M6
7	12647001	2-I10	16	13407211	2-Q8	9	13866050	2-N13	37	14164170	1-N6	4	14274631	1-H3
7	12647001	2-I8	19	13407211	2-Q4	16	13868350	1-O6	6	14164370	2-H12	4	14274631	2-N3
15	12647001	2-M8	17	13407211	2-Q2	28	13879640	2-L5	14	14164770	3-L14	4	14274731	2-M4
11	12647101	1-M15	14	13407211	2-R13	19	13914070	2-P13	14	14165470	1-H4	5	14275231	2-M4
2	12648260	1-M8	14	13407211	3-H17	18	13914070	2-P16	14	14165470	1-H6	16	14282170	1-H7
14	12948810	2-I8	2	13407811	2-M5	13	13914070	2-P17	9	14167770	2-I6	16	14282370	1-H5
8	13275811	2-T6	19	13449521	1-P12	21	14048217	1-O11	8	14168070	2-L6	17	14282470	1-H5
8	13275811	2-T14	38	13516221	1-I13	9	14054511	3-I3	15	14168070	2-L7	17	14282470	1-H7
40	13276801	1-M4	38	13516221	1-I11	19	14054911	2-R8	37	14171470	2-Q14	15	14282770	1-H4
8	13277411	3-I3	15	13516721	1-H5	12	14073910	2-Q10	38	14173570	2-Q13	18	14282770	1-H5
10	13279217	3-L13	15	13516721	1-H7	17	14073910	2-Q8	27	14173570	2-Q11	15	14282770	1-H6
16	13279611	1-L7	12	13516811	1-I10	5	14084211	2-T3	39	14196670	1-I13	18	14282770	1-H7
2	13297317	3-I11	16	13516821	1-O12	3	14085811	2-N12	39	14196670	1-I11	19	14282970	1-H5

ITEM	PART N.	GRID	ITEM	PART N.	GRID	ITEM	PART N.	GRID	ITEM	PART N.	GRID	ITEM	PART N.	GRID
7	11307031	2-I6	20	11702921	2-P15	23	12163527	2-Q11	13	12182190	1-P7	11	12642801	3-H17
17	11343721	1-P12	17	11702921	2-I	21	12164011	1-H10	14	12182290	1-P2	36	12642801	3-I15
8	11343831	2-I4	12	11702921	2-P17	10	12164011	1-M15	6	12183190	1-I3	9	12642801	3-I13
5	11369621	3-I10	34	11702921	2-Q14	9	12164021	2-I4	7	12214111	3-I3	2	12643701	3-I6
27	11394331	2-L5	7	11702921	2-T6	7	12164021	2-N5	25	12574211	1-L5	13	12644320	3-L9
19	11408321	1-H10	5	11702921	2-T16	6	12164127	3-M14	1	12574211	3-I6	12	12644321	2-O17
33	11408331	2-Q14	7	11702921	3-H2	4	12164127	3-M13	6	12574511	3-I10	11	12644321	3-L14
24	11408331	2-Q11	11	11703227	2-Q10	9	12164327	2-L10	4	12574521	2-R2	12	12644401	1-O6
17	11408331	2-Q4	16	11703227	2-Q9	18	12164711	1-P12	13	12575127	2-R13	16	12644421	3-I16
15	11408331	2-Q2	15	11703227	2-Q8	10	12164711	2-H17	7	12598371	3-L13	8	12644421	3-L13
7	11408331	2-S9	16	11703227	2-Q7	9	12164711	2-L13	23	12605671	2-R10	2	12644921	2-N12
5	11408537	2-M3	18	11703227	2-Q4	18	12164711	2-O17	10	12605770	2-L13	24	12646601	1-L5
9	11500210	1-M7	16	11703227	2-Q2	11	12164711	2-S3	14	12638101	2-M2	1	12646621	3-L8
19	11690921	2-R3	20	11797720	1-H10	5	12164721	1-O13	13	12638601	1-L7	9	12646701	2-H14
7	11701711	1-L8	20	11797824	1-H10	5	12164721	2-M11	6	12638601	1-O13	25	12646721	1-I8
6	11701721	1-L11	12	11902017	1-P16	13	12173890	1-P7	5	12638601	2-H9	11	12646721	1-L3
25	11701721	2-H10	1	11902017	2-H11	4	12173890	3-H15	8	12638601	2-H14	13	12646721	1-O6
3	11701721	2-H13	13	11902111	O10	13	12173990	2-L15	8	12638601	3-I10	2	12646721	1-O4
20	11701721	2-M16	14	11903011	1-O15	6	12173990	2-M17	6	12638601	3-L12	5	12646721	1-O3
10	11701721	2-N16	13	11903211	1-H4	6	12174090	1-I3	9	12638621	1-L3	17	12646721	3-I16
6	11701721	2-N17	10	11903211	1-P7	13	12174090	1-P4	6	12638621	1-L5	10	12646721	3-I13
6	11701721	2-O17	22	11903211	2-R10	8	12174490	1-L8	4	12638621	1-O3	14	12646721	3-L9
5	11701721	2-O10	13	11903717	1-P16	13	12174490	1-M13	15	12638621	2-N14	12	12646721	3-L14
5	11701721	2-O9	2	11903717	2-H11	9	12174590	1-L8	12	12638621	2-R5	11	12646801	1-L8
11	11701721	2-O8	6	11903917	1-O8	14	12174790	1-P2	8	12638621	3-L6	7	12646801	2-R4
11	11701721	2-O3	6	11945008	2-S5	14	12174790	1-P4	10	12638621	3-L14	8	12646801	2-S3
7	11701721	2-P8	7	11947708	2-S5	14	12174790	2-N14	14	12638660	2-I15	9	12646820	3-L11
8	11701721	2-T12	6	12035571	2-T3	11	12174790	2-N16	14	12639701	1-L7	8	12646821	1-L11
15	11701721	3-I16	11	12077086	1-P7	10	12174990	1-L8	34	12639701	1-N6	14	12646821	1-O6
5	11701721	3-L12	12	12077186	1-P7	15	12179490	1-I2	8	12642021	3-L17	32	12646821	2-H15
9	11701721	3-L14	14	12163327	2-P11	20	12179490	1-L16	5	12642021	3-M12	12	12646821	2-N16
7	11702921	1-L11	21	12163327	2-P15	31	12179490	1-M17	9	12642401	1-I6	7	12646821	2-N17
4	11702921	1-O13	18	12163327	2-Q4	20	12179490	1-M14	10	12642701	1-L3	7	12646821	2-O17
11	11702921	1-O6	16	12163327	2-Q2	9	12179590	3-I5	7	12642701	1-L5	12	12646821	2-O8
13	11702921	2-P13	35	12163527	2-Q14	14	12179990	1-P7	15	12642701	1-L7	12	12646821	2-O3

ITEM	PART N.	GRID	ITEM	PART N.	GRID	ITEM	PART N.	GRID	ITEM	PART N.	GRID	ITEM	PART N.	GRID
17	11106631	2-F7	12	11112431	2-N14	15	11115831	2-Q9	14	11193871	2-N11	13	11198371	1-O2
1	11106831	2-O17	6	11112431	2-P9	15	11115831	2-Q7	6	11193871	2-S4	12	11198371	1-P4
3	11106831	2-O12	12	11112431	2-P10	13	11116031	2-P10	4	11193879	2-S3	16	11198371	1-P11
5	11106831	2-O5	11	11112431	2-P11	12	11116031	2-P11	6	11194071	1-L8	2	11198371	2-H16
18	11106831	2-R3	12	11112431	2-Q17	13	11116031	2-Q17	24	11194071	1-N9	7	11198371	2-S4
4	11107031	2-H9	10	11112431	3-H17	6	11116831	2-S17	19	11195470	1-L16	2	11198374	2-H16
5	11107031	2-M17	12	11112431	3-I13	14	11117031	2-Q8	9	11195470	1-M13	21	11198571	1-H14
5	11107031	2-N17	9	11112431	3-L9	9	11117831	2-R17	32	11195470	1-N6	2	11198671	1-O9
5	11107031	2-O17	14	11112631	1-I2	12	11118731	3-L9	13	11195471	2-M2	8	11198671	2-S4
5	11107031	2-O14	14	11112631	3-I16	13	11120631	2-P11	8	11195471	3-I5	6	11198679	2-S3
4	11107031	2-O11	29	11112631	3-I12	19	11120637	2-P15	9	11197771	1-H11	16	11200171	1-H10
3	11107031	2-O9	8	11112631	3-L11	4	11125931	3-L12	9	11197771	1-H12	6	11227031	2-N5
5	11107231	2-O13	10	11112831	3-L9	13	11190571	1-O2	28	11197771	1-M17	12	11234721	1-O10
7	11107231	3-L6	13	11113031	2-N14	12	11190571	1-P4	13	11197771	2-M15	12	11234721	1-O9
9	11107331	2-N14	11	11113231	3-L9	14	11190579	1-H7	15	11197771	2-N11	9	11239111	2-L15
3	11107331	2-O10	6	11113331	2-O4	5	11190579	2-S9	13	11198071	1-H5	5	11255931	3-M14
19	11107331	2-P7	7	11113331	2-P8	5	11190579	2-S3	14	11198071	1-H9	3	11255931	3-M13
4	11107431	2-O10	9	11113431	2-N16	29	11193871	1-H8	10	11198071	1-H11	10	11262011	2-L15
10	11107531	2-N14	6	11113431	2-O5	14	11193871	1-H9	37	11198071	1-I13	11	11265511	2-L15
4	11107531	2-O9	13	11113431	2-P15	35	11193871	1-I11	37	11198071	1-I11	17	11306921	1-H10
8	11107731	2-N16	16	11113631	2-P13	4	11193871	1-I7	10	11198071	1-I10	20	11306921	1-O9
11	11108031	2-N14	16	11113631	2-P16	5	11193871	1-I6	10	11198071	1-I9	4	11306921	3-I10
9	11108231	2-O8	11	11113631	2-P17	27	11193871	1-M17	11	11198071	1-I5	11	11306924	1-M13
9	11108231	2-O3	10	11113731	1-O6	9	11193871	1-M15	13	11198071	1-O15	7	11306924	2-S9
6	11108231	2-P3	17	11113731	2-P13	12	11193871	1-O15	15	11198071	1-O12	6	11306931	2-I6
23	11108231	2-Q16	30	11114031	2-Q14	14	11193871	1-O12	10	11198071	1-O10	12	11306931	2-L15
8	11108431	2-N13	31	11114431	2-Q14	14	11193871	1-O11	11	11198071	1-O7	2	11306931	2-M13
10	11108631	2-O8	32	11114631	2-Q14	10	11193871	1-O9	5	11198071	1-P10	3	11306931	2-M7
10	11108631	2-O3	17	11115531	2-Q4	12	11193871	1-O2	14	11198071	2-M15	18	11307021	1-H10
7	11108631	2-P3	14	11115531	2-Q2	11	11193871	1-P4	14	11198371	1-H5	30	11307021	1-M17
13	11112231	2-Q8	24	11115631	2-Q6	9	11193871	1-P7	15	11198371	1-H9	3	11307021	2-H16
4	11112231	3-M17	4	11115631	3-M12	8	11193871	1-P8	29	11198371	1-M17	9	11307021	2-H17
5	11112431	1-L11	13	11115831	2-P10	8	11193871	1-P9	16	11198371	1-M13	9	11307021	3-I10
3	11112431	1-O13	13	11115831	2-Q17	5	11193871	1-P10	11	11198371	1-O10	3	11307024	2-H16
9	11112431	1-O6	10	11115831	2-Q10	15	11193871	1-P11	11	11198371	1-O9	5	11307031	1-P15

ITEM	PART N.	GRID	ITEM	PART N.	GRID	ITEM	PART N.	GRID	ITEM	PART N.	GRID	ITEM	PART N.	GRID
22	10734201	1-L7	1	10839510	2-N12	20	10979231	3-L6	8	11103031	3-L9	11	11106231	2-Q17
3	10734201	2-H14	5	10839510	2-P9	4	10979231	3-L7	6	11103031	3-L16	9	11106231	2-Q10
25	10734201	2-L4	12	10839610	1-H4	6	10979331	2-S9	5	11106031	1-O8	14	11106231	2-Q9
35	10734201	2-R9	12	10839610	1-H6	7	10979331	2-T12	6	11106031	2-N16	14	11106231	2-Q7
10	10734201	3-I16	8	10839610	1-H11	10	10979331	3-H2	3	11106031	2-D14	4	11106231	2-T16
4	10734201	3-L11	8	10839610	1-H12	3	10979331	3-H3	4	11106031	2-O7	4	11106231	2-T17
6	10734201	3-L14	10	10839610	1-O7	4	10979421	3-H6	4	11106031	2-O8	4	11106231	3-H7
39	10734301	1-M4	8	10839610	2-S14	18	10979431	3-H3	5	11106031	2-O4	4	11106231	3-H8
13	10734308	1-P11	15	10839710	1-H9	6	10979440	3-H16	4	11106031	2-O2	8	11106231	3-I13
22	10734401	1-N4	1	10858090	3-L2	6	11052090	2-T6	4	11106031	2-P4	6	11106231	3-L11
20	10734401	2-H13	2	10863190	3-L2	6	11052090	2-T14	5	11106031	2-P8	6	11106231	3-L13
5	10734601	2-L3	1	10902021	1-M2	30	11059376	1-H17	3	11106031	2-P12	7	11106231	3-L17
41	10734601	2-L5	6	10902021	2-N13	17	11059776	2-R8	6	11106031	2-R4	12	11106231	3-M15
6	10734601	2-L6	5	10902021	3-I3	3	11060676	1-H3	11	11106031	2-R5	4	11106231	3-M14
16	10788721	2-R3	12	10902031	2-T15	14	11061576	1-P11	13	11106031	2-T8	19	11106321	2-Q17
4	10788721	3-I3	4	10902121	3-L13	14	11062175	2-S12	5	11106031	3-L13	3	11106331	2-N17
5	10788721	3-L11	7	10902131	2-N13	14	11062175	2-S11	7	11106031	3-L16	7	11106331	2-O8
31	10788811	1-N6	25	10902221	1-M17	32	11065876	1-N6	6	11106031	3-L17	7	11106331	2-O3
11	10791021	3-I16	12	10902311	1-N7	8	11065976	2-L15	13	11106131	3-I16	7	11106431	2-N16
5	10791221	2-H14	13	10902321	2-N11	5	11066276	2-I13	3	11106231	1-L11	21	11106431	2-Q16
10	10791221	2-L14	3	10902421	3-H8	26	11066376	2-L4	8	11106231	1-O6	17	11106431	2-R3
8	10791311	2-T3	6	10902421	3-I6	36	11066675	1-I13	3	11106231	1-O3	12	11106431	3-H2
6	10791321	2-L3	12	10902524	1-H12	36	11066675	1-I11	7	11106231	2-H14	4	11106431	3-H3
21	10791411	2-R10	3	10902621	3-H15	12	11066876	2-L14	8	11106231	2-N14	9	11106431	3-H17
5	10794040	3-H16	12	10902631	3-I16	10	11069375	1-I5	3	11106231	2-O16	7	11106431	3-L11
7	10795001	1-L3	22	10902821	1-L5	27	11069376	2-I8	3	11106231	2-O15	3	11106431	3-L12
12	10796301	1-L7	12	10902821	2-M15	7	11075476	2-I4	4	11106231	2-O14	8	11106431	3-L14
4	10796301	3-L16	3	10902821	3-H7	6	11087876	3-I3	4	11106231	2-O13	3	11106431	3-M17
8	10796401	1-L3	15	10903631	2-M17	18	11087976	2-R8	2	11106231	2-O10	4	11106631	1-L11
5	10796401	1-L5	2	10960637	2-L8	3	11088076	2-H12	2	11106231	2-O9	8	11106631	2-H9
11	10796401	2-L14	7	10977821	3-I5	2	11088076	2-H13	8	11106231	2-O6	5	11106631	2-H12
10	10796401	2-R5	18	10978021	1-L16	6	11088076	2-H14	8	11106231	2-P2	4	11106631	2-N17
6	10796401	3-L6	26	10978221	1-M17	29	11090037	2-Q14	8	11106231	2-P5	3	11106631	2-O11
5	10796401	3-L16	8	10978221	1-M13	4	11090037	2-Q12	6	11106231	2-P8	8	11106631	2-O8
7	10797101	3-L14	5	10979231	1-L10	4	11103031	2-H12	11	11106231	2-P10	8	11106631	2-O3

ITEM	PART N.	GRID	ITEM	PART N.	GRID	ITEM	PART N.	GRID	ITEM	PART N.	GRID	ITEM	PART N.	GRID
17	10517271	2-P15	1	10519601	2-O14	8	10569470	2-O17	30	10571779	1-Q13	2	10571871	3-H7
27	10517271	2-Q14	1	10519601	2-O13	4	10571379	2-T3	5	10571779	1-Q10	2	10571871	3-H8
21	10517271	2-Q11	2	10519601	3-I8	1	10571470	3-I2	30	10571779	1-R3	7	10571871	3-I13
15	10517271	2-Q4	2	10519601	3-M6	4	10571471	1-L3	5	10571779	1-R5	5	10571871	3-L6
13	10517271	2-Q3	20	10519621	1-M13	24	10571471	1-L17	30	10571779	1-R11	3	10571871	3-L7
2	10517271	3-L9	10	10519621	1-P4	3	10571570	3-I8	5	10571779	1-R14	6	10571871	3-L9
3	10517271	3-M14	2	10519621	3-L6	4	10571571	2-T6	30	10571779	1-S3	2	10571871	3-L12
2	10517271	3-M13	2	10519621	3-L7	4	10571571	2-T14	5	10571779	1-T3	7	10571970	2-N14
6	10517371	2-I4	4	10519621	3-L14	11	10571571	2-T15	30	10571779	1-T9	2	10571971	1-L11
4	10517371	2-M3	2	10519621	3-L16	2	10571571	2-T16	5	10571779	1-T12	4	10571971	2-O4
8	10517371	2-Q10	4	10519621	3-L17	3	10571571	2-T17	3	10571779	3-M6	15	10571971	2-P13
12	10517371	2-Q9	12	10519660	1-H5	1	10571571	3-H7	11	10571870	3-H2	14	10571971	2-P16
12	10517371	2-Q8	12	10519660	1-H7	1	10571571	3-H8	5	10571870	3-I8	10	10571971	2-P17
12	10517371	2-Q7	2	10520001	1-O13	7	10571571	3-I16	3	10571870	3-I3	9	10571971	3-I16
15	10517371	2-Q4	16	10520001	2-L7	2	10571571	3-I3	4	10571871	1-L10	30	10571971	3-I12
13	10517371	2-Q2	6	10520001	2-L14	2	10571579	1-M2	1	10571871	1-L11	7	10571971	3-L9
2	10517471	1-H3	3	10520020	3-L11	21	10571579	2-M16	4	10571871	1-O8	1	10572071	2-N4
4	10517471	2-L9	7	10520021	2-L14	17	10571579	3-H3	2	10571871	2-H12	7	10572170	3-I10
8	10517471	2-L10	4	10520021	3-I13	4	10571770	3-I8	1	10571871	2-H13	15	10572171	2-P16
2	10517471	2-M6	3	10520021	3-L16	9	10571771	1-I9	2	10571871	2-H14	1	10572371	2-L8
28	10517471	2-Q14	4	10520101	2-I13	13	10571771	1-I2	8	10571871	2-H17	4	10572371	2-P8
25	10517471	2-Q11	4	10520101	2-L3	5	10571771	1-L3	1	10571871	2-L2	5	10725911	2-N13
7	10517471	3-H17	40	10520101	2-L5	3	10571771	1-L5	5	10571871	2-O11	3	10725911	3-H16
3	10517471	3-L9	3	10520121	1-L3	5	10571771	2-T6	7	10571871	2-O6	4	10725940	3-H16
4	10519201	2-N13	2	10520121	1-L5	11	10571771	2-T8	7	10571871	2-P2	15	10726011	1-M2
2	10519221	1-L3	28	10520121	2-Q6	5	10571771	2-T11	7	10571871	2-P5	8	10731101	2-L14
2	10519301	3-I5	5	10520121	2-S8	6	10571771	2-T12	18	10571871	2-P7	24	10733601	2-L4
1	10519401	3-I8	2	10520121	3-M12	2	10571771	2-T15	3	10571871	2-P8	5	10733601	2-L6
6	10519421	3-I16	4	10520201	2-L6	3	10571771	3-H6	10	10571871	2-P10	4	10733601	2-L7
3	10519421	3-I13	2	10520201	3-I10	8	10571771	3-I16	2	10571871	2-P12	9	10733601	2-L14
10	10519601	1-H12	4	10520221	3-L9	6	10571771	3-I13	10	10571871	2-Q17	13	10733901	2-O9
10	10519601	1-I4	5	10520221	3-L14	4	10571771	3-L6	12	10571871	2-T8	13	10733901	2-Q7
12	10519601	1-O15	3	10520421	2-M6	5	10571771	3-L9	6	10571871	2-T11	30	10734101	1-N6
5	10519601	1-P10	8	10520421	3-H17	5	10571771	3-L17	3	10571871	2-T16	6	10734201	1-L3
23	10519601	2-L4	3	10569371	3-L6	3	10571771	3-M12	2	10571871	3-H3	4	10734201	1-L5

ITEM	PART N.	GRID	ITEM	PART N.	GRID	ITEM	PART N.	GRID	ITEM	PART N.	GRID	ITEM	PART N.	GRID
23	10441390	1-L17	3	10516671	2-L3	6	10516871	2-L15	5	10516871	3-I16	16	10517071	2-P15
10	10441390	1-M13	3	10516671	2-M17	4	10516871	2-M17	1	10516871	3-I13	8	10517071	2-Q17
2	10441590	2-T6	14	10516671	2-M8	1	10516871	2-M13	1	10516871	3-L11	25	10517071	2-Q14
2	10441590	2-T14	4	10516671	2-N5	6	10516871	2-M11	1	10516871	3-L12	10	10517071	2-Q8
15	10445024	2-T3	2	10516671	2-N13	2	10516871	2-M7	3	10516871	3-L13	5	10517071	2-T12
1	10449890	2-T12	1	10516671	2-N17	3	10516871	2-N13	3	10516871	3-L14	2	10517071	2-T17
1	10449890	2-T16	1	10516671	2-O16	5	10516871	2-N14	1	10516871	3-L16	6	10517071	3-H17
1	10449890	2-T17	1	10516671	2-O15	4	10516871	2-N16	3	10516871	3-L17	2	10517071	3-I13
3	10450090	2-T6	14	10516671	2-O14	2	10516871	2-N17	1	10516871	3-M17	2	10517071	3-L11
2	10450090	2-T12	2	10516671	2-O7	2	10516871	2-O17	11	10516871	3-M15	2	10517071	3-M17
1	10450090	2-T15	2	10516671	2-O4	2	10516871	2-O16	1	10516871	3-M14	4	10517171	1-P15
16	10450190	3-H5	2	10516671	2-O2	2	10516871	2-O15	3	10516879	1-Q3	5	10517171	2-I4
3	10450290	2-T12	2	10516671	2-P4	17	10516871	2-O14	1	10516879	1-R2	22	10517171	2-L4
10	10450390	1-I2	15	10516671	2-R3	2	10516871	2-O13	1	10516879	1-R10	7	10517171	2-L10
2	10450390	2-T11	4	10516671	2-R4	2	10516871	2-O12	3	10516879	1-S16	5	10517171	2-N5
3	10450690	2-T11	16	10516671	2-R8	2	10516871	2-O11	1	10516879	1-T8	9	10517171	2-P10
11	10450790	1-I2	20	10516671	2-R10	1	10516871	2-O10	3	10516879	1-T10	9	10517171	2-P11
4	10450790	2-T11	1	10516671	3-I11	1	10516871	2-O9	3	10516879	1-T17	9	10517171	2-Q17
4	10450790	2-T12	2	10516671	3-L14	6	10516871	2-O8	21	10516879	2-Q16	26	10517171	2-Q14
21	10489510	2-L4	2	10516671	3-L17	3	10516871	2-O7	1	10516879	3-M6	20	10517171	2-Q11
12	10511771	1-I2	1	10516671	3-M10	2	10516871	2-O5	38	10517070	1-M4	7	10517171	2-Q10
32	10516470	1-M6	1	10516671	3-M9	3	10516871	2-C4	7	10517070	2-P6	11	10517171	2-Q9
21	10516470	1-N4	1	10516671	3-M8	6	10516871	2-O3	1	10517071	1-O13	11	10517171	2-Q8
2	10516470	3-H15	5	10516821	2-O8	3	10516871	2-O2	7	10517071	1-O6	11	10517171	2-Q7
1	10516471	2-N13	5	10516821	2-O3	5	10516871	2-P3	8	10517071	2-L13	14	10517171	2-Q5
2	10516471	3-H16	8	10516870	2-H17	3	10516871	2-P4	7	10517071	2-L15	12	10517171	2-Q3
4	10516471	3-H17	17	10516870	2-O17	6	10516871	2-Q10	1	10517071	2-M6	8	10517171	2-R17
2	10516471	3-L13	5	10516871	1-L8	10	10516871	2-Q9	2	10517071	2-N3	4	10517171	2-S17
1	10516671	1-H3	6	10516871	1-O6	10	10516871	2-O7	6	10517071	2-N14	1	10517171	3-L9
11	10516671	1-L7	2	10516871	1-O3	5	10516871	2-R4	5	10517071	2-N16	2	10517171	3-M14
5	10516671	1-O6	3	10516871	1-P15	9	10516871	2-R5	3	10517071	2-O5	1	10517171	3-M13
1	10516671	1-O4	3	10516871	2-H9	4	10516871	2-S9	8	10517071	2-P6	1	10517171	3-M12
1	10516671	1-O3	5	10516871	2-I6	14	10516871	3-H2	4	10517071	2-P9	25	10517179	2-Q6
6	10516671	2-I10	4	10516871	2-I4	1	10516871	3-H3	8	10517071	2-P10	12	10517271	2-M2
6	10516671	2-I8	7	10516871	2-L13	5	10516871	3-H17	8	10517071	2-P11	10	10517271	2-P11

ITEM	PART N.	GRID	ITEM	PART N.	GRID	ITEM	PART N.	GRID	ITEM	PART N.	GRID	ITEM	PART N.	GRID
8	8299754	2-R15	11	9930027	1-N15	10	10205910	1-I15	29	10273101	1-M6	8	10296685	1-P4
9	8299755	2-R15	1	9931247	1-N15	14	10205920	2-R3	15	10273111	1-O9	4	10297080	2-I6
14	8299999	2-P13	4	10005010	2-L14	3	10205920	2-R4	3	10273111	2-M3	3	10297080	2-I4
13	8299999	2-P16	9	10050811	1-L7	36	10206220	1-M4	6	10278301	2-R5	2	10297760	1-N16
9	8299999	2-P17	6	10119040	2-R5	12	10212210	2-I8	16	10278311	2-R10	8	10298360	1-O10
2	8322167	1-L13	23	10119140	2-I4	31	10231240	2-I5	32	10278660	3-I5	3	10298360	1-O8
3	8322178	1-L13	23	10119440	1-L2	21	10231240	2-I4	11	10279560	1-I5	9	10298360	2-T8
3	8323149	1-L10	27	10124411	1-L5	10	10248271	1-L7	11	10279560	1-H7	11	10298460	1-H6
1	9918431	3-H5	26	10124876	1-L5	5	10248471	2-L14	5	10279980	2-L15	13	10300511	1-H6
8	9918625	1-N3	9	10138386	1-O2	1	10253900	3-L13	8	10279985	1-I2	2	10300511	1-P15
1	9926025	2-N10	12	10160401	1-P11	6	10257050	2-H17	22	10280060	1-L17	22	10300571	2-M9
2	9926027	2-N10	28	10160500	2-I8	12	10257060	2-H11	18	10280060	1-M13	1	10300571	2-N14
3	9926031	2-N10	9	10160701	1-H4	15	10257060	2-R10	10	10280060	1-O2	11	10300611	1-O2
4	9926033	2-N10	9	10160701	1-H6	7	10257060	2-T8	13	10280060	2-R12	30	10300671	2-N15
2	9927292	3-H5	1	10165340	1-O8	6	10257385	1-P7	29	10282460	2-N15	9	10300711	1-P4
2	9927795	2-S6	2	10166040	1-O8	7	10257460	1-P7	7	10284460	2-M11	7	10300711	2-H17
1	9928366	1-N13	4	10168790	1-L8	4	10257460	2-L15	15	10284460	2-R8	19	10300721	2-R10
2	9928367	1-N13	21	10181711	1-M14	10	10257460	2-M10	6	10287380	3-H11	16	10300911	2-H11
3	9928369	1-N13	7	10181711	1-M13	8	10257460	2-T8	4	10287380	3-H13	12	10305171	1-H9
4	9928370	1-N13	3	10181717	2-O8	5	10260060	1-I3	8	10287385	1-P7	35	10329910	1-I13
5	9928371	1-N13	3	10181717	2-O3	3	10260060	2-N5	11	10296160	1-H4	8	10332810	2-R5
6	9928373	1-N13	3	10181717	2-P3	4	10260060	2-N14	22	10296160	1-M14	1	10352442	3-H16
7	9928374	1-N13	24	10182217	2-H10	12	10260060	2-R12	17	10296160	1-M13	29	10376611	1-N6
8	9928375	1-N13	2	10182617	2-L15	21	10260160	1-L17	1	10296160	1-P15	30	10376711	1-M6
9	9928376	1-N13	19	10182811	1-L17	10	10260160	1-O15	11	10296160	2-H11	19	10376711	1-N4
2	9928391	1-N15	10	10183217	2-H11	18	10263160	1-O9	15	10296160	2-M10	31	10377611	1-M6
3	9928392	1-N15	1	10183717	2-H9	11	10263460	1-H9	4	10296160	2-N14	20	10378811	1-N4
10	9928396	1-N13	12	10184311	1-M13	2	10263460	2-M17	4	10296160	2-O8	11	10389511	2-M2
4	9930019	1-N15	7	10184317	1-I2	5	10263460	2-R5	4	10296160	2-O3	37	10390811	1-M4
5	9930021	1-N15	20	10184317	1-L17	2	10264080	2-M3	4	10296160	2-P3	1	10397380	2-T11
6	9930022	1-N15	3	10184317	2-L15	14	10264560	2-R8	17	10296160	2-R10	1	10397680	3-I5
7	9930023	1-N15	5	10184517	1-P7	10	10265460	1-H4	2	10296260	2-H9	1	10399280	2-T6
8	9930024	1-N15	28	10205610	1-N5	10	10265460	1-H6	18	10296260	2-R10	10	10405485	2-T8
9	9930025	1-N15	8	10205820	1-M15	11	10269450	2-M10	7	10296585	2-R5	2	10440990	3-H6
10	9930026	1-N15	10	10205910	1-I16	2	10273011	2-I4	9	10296685	1-I2	10	10441190	2-T15

ITEM	PART N.	GRID	ITEM	PART N.	GRID	ITEM	PART N.	GRID	ITEM	PART N.	GRID	ITEM	PART N.	GRID
32	8295966	2-R9	1	8296665	2-O12	4	8297617	2-Q17	14	8298503	2-R10	11	8298705	2-P15
6	8295967	2-R10	5	8296667	2-R12	5	8297638	2-P10	5	8298583	2-Q10	12	8298713	2-P15
31	8295969	2-R9	6	8296669	2-R12	5	8297638	2-Q17	8	8298583	2-Q9	13	8298716	2-P15
7	8295970	2-R10	7	8296670	2-R12	1	8297638	2-Q10	7	8298583	2-Q8	14	8298721	2-P15
8	8295971	2-R10	8	8296672	2-R12	1	8297638	2-Q9	8	8298583	2-Q7	15	8298724	2-P15
9	8295973	2-R10	9	8296676	2-R12	1	8297638	2-Q7	7	8298586	2-R13	8	8298727	2-Q8
6	8295975	2-R8	10	8296677	2-R12	2	8297712	2-Q9	8	8298590	2-R13	9	8298745	2-Q8
7	8295976	2-R8	11	8296678	2-R12	2	8297721	2-Q10	9	8298593	2-Q9	7	8298761	2-P13
8	8295977	2-R8	24	8296713	2-Q14	3	8297721	2-Q9	9	8298593	2-Q7	8	8298762	2-P13
10	8295981	2-R10	5	8296713	2-Q12	3	8297721	2-Q7	3	8298596	2-R17	8	8298762	2-P16
11	8295982	2-R10	17	8296794	2-S11	7	8297742	2-R3	4	8298599	2-R17	9	8298766	2-P13
12	8295983	2-R10	18	8296795	2-S11	8	8297743	2-R3	5	8298600	2-R17	10	8298768	2-P13
9	8295984	2-R8	4	8296796	2-P6	9	8297744	2-R3	6	8298601	2-R17	9	8298768	2-P16
10	8295989	2-R8	1	8296969	2-P10	10	8297751	2-R3	7	8298602	2-R17	5	8298768	2-P17
11	8295991	2-R8	1	8296969	2-Q17	11	8297752	2-R3	9	8298606	2-R13	11	8298770	2-P13
12	8295992	2-R8	2	8296970	2-P10	12	8297753	2-R3	10	8298607	2-R13	10	8298770	2-P16
13	8295995	2-R10	2	8296970	2-Q17	1	8297995	2-O7	11	8298608	2-R13	6	8298770	2-P17
7	8296152	2-Q3	3	8296975	2-P10	1	8297995	2-O2	12	8298609	2-R13	12	8298771	2-P13
8	8296167	2-Q3	3	8296975	2-Q17	1	8297995	2-P4	7	8298615	2-R16	11	8298771	2-P16
9	8296169	2-Q3	4	8297073	2-R16	4	8298052	2-R15	6	8298615	2-S15	7	8298771	2-P17
10	8296170	2-Q3	3	8297073	2-S15	5	8298055	2-R15	7	8298615	2-S14	13	8298772	2-P13
15	8296177	2-Q12	4	8297073	2-S14	2	8298364	2-S10	5	8298657	2-P11	12	8298772	2-P16
11	8296177	2-Q3	5	8297074	2-R16	3	8298365	2-S10	7	8298657	2-P15	8	8298772	2-P17
4	8296250	2-R3	4	8297074	2-S15	4	8298366	2-S10	6	8298659	2-P11	13	8298969	2-R3
5	8296430	2-R3	5	8297074	2-S14	5	8298367	2-S10	8	8298659	2-P15	2	8299095	2-R4
6	8296431	2-R3	6	8297075	2-R16	4	8298387	2-Q9	7	8298660	2-P11	1	8299534	2-O6
6	8296559	2-P13	5	8297075	2-S15	4	8298387	2-Q7	9	8298660	2-P15	1	8299534	2-P2
7	8296559	2-P16	6	8297075	2-S14	5	8298398	2-Q9	6	8298667	2-P10	1	8299534	2-P5
23	8296563	2-Q14	3	8297172	2-N14	5	8298398	2-Q7	6	8298667	2-Q17	6	8299623	2-Q5
16	8296563	2-Q12	4	8297294	2-R13	6	8298403	2-Q9	19	8298668	2-Q17	8	8299624	2-Q5
23	8296564	2-Q14	5	8297295	2-R13	6	8298403	2-Q7	7	8298671	2-P10	7	8299625	2-Q5
17	8296564	2-Q11	6	8297296	2-R13	7	8298412	2-Q9	7	8298671	2-Q17	9	8299688	2-Q5
18	8296574	2-Q11	13	8297427	2-Q5	7	8298412	2-Q7	18	8298672	2-Q17	4	8299688	2-Q3
30	8296629	2-R9	4	8297617	2-P10	3	8298482	2-Q10	1	8298700	2-P14	6	8299740	2-R15
13	8296630	2-R8	4	8297617	2-P11	4	8298497	2-Q10	10	8298703	2-P15	7	8299752	2-R15

ITEM	PART N.	GRID	ITEM	PART N.	GRID	ITEM	PART N.	GRID	ITEM	PART N.	GRID	ITEM	PART N.	GRID
8	8273918	2-M11	1	8280842	2-P11	10	8283325	2-Q5	5	8287305	2-R10	12	8290222	2-S12
9	8273919	2-M12	2	8280936	2-P11	5	8283325	2-Q3	1	8287493	2-O5	12	8290222	2-S11
9	8273919	2-M11	1	8280936	2-Q8	1	8283346	2-P6	2	8287493	2-P6	3	8291505	2-R15
10	8273920	2-M12	4	8280936	2-Q5	19	8283478	2-M12	3	8287802	2-P6	3	8291506	2-R13
10	8273920	2-M11	2	8280936	2-Q3	4	8283916	2-Q8	18	8287899	2-Q15	13	8291507	2-S12
11	8273940	2-M12	17	8281201	2-M12	11	8283916	2-Q5	11	8287899	2-Q12	13	8291507	2-S11
11	8273940	2-M11	17	8281201	2-M11	6	8283916	2-Q3	19	8288219	2-Q15	3	8291561	2-R16
12	8273968	2-M12	3	8281253	2-R10	1	8284842	2-O4	12	8288219	2-Q12	2	8291561	2-S15
13	8273969	2-M12	18	8281576	2-M12	2	8285297	2-P13	4	8288798	2-P6	3	8291561	2-S14
14	8274234	2-M12	18	8281576	2-M11	3	8285297	2-P16	5	8288803	2-S12	1	8291706	2-O8
14	8274234	2-M11	1	8281744	2-S10	2	8285297	2-P17	5	8288803	2-S11	1	8291706	2-O3
15	8280168	2-M12	2	8281824	2-R15	3	8285298	2-P13	6	8288804	2-S12	1	8291706	2-P3
15	8280168	2-M11	11	8281853	2-Q15	4	8285298	2-P16	6	8288804	2-S11	2	8291707	2-O8
16	8280169	2-M12	6	8281853	2-Q12	3	8285298	2-P17	7	8288805	2-S12	2	8291707	2-O3
1	8280310	2-P15	1	8282867	2-R2	4	8285330	2-P13	7	8288805	2-S11	2	8291707	2-P3
2	8280332	2-P16	2	8282869	2-R2	5	8285330	2-P16	8	8288806	2-S12	3	8291836	3-H17
2	8280332	2-Q15	3	8282870	2-R2	4	8285330	2-P17	8	8288806	2-S11	2	8291846	2-S17
3	8280332	2-Q12	2	8283007	2-P15	1	8285377	2-P9	9	8288807	2-S12	3	8292259	2-S17
3	8280389	2-Q5	12	8283007	2-Q15	2	8285378	2-P9	9	8288807	2-S11	20	8292408	2-Q14
39	8280391	2-Q13	7	8283007	2-Q12	3	8285379	2-P9	10	8288808	2-S12	13	8292408	2-Q12
1	8280391	2-R15	1	8283007	2-S12	12	8285653	2-Q5	10	8288808	2-S11	21	8292410	2-Q14
4	8280393	2-Q15	1	8283007	2-S11	4	8285654	2-P15	11	8288810	2-S12	14	8292410	2-Q12
5	8280395	2-Q15	3	8283053	2-P15	13	8285654	2-Q15	11	8288810	2-S11	3	8292689	2-R12
6	8280397	2-Q15	2	8283053	2-Q8	8	8285654	2-Q12	2	8288822	2-R13	4	8293970	2-Q12
7	8280398	2-Q15	5	8283053	2-Q5	14	8285655	2-Q15	1	8288832	2-M7	3	8294287	2-R3
8	8280400	2-Q15	3	8283053	2-Q3	9	8285655	2-Q12	1	8288832	2-P12	6	8295477	2-Q8
9	8280721	2-Q15	1	8283053	2-S17	15	8285656	2-Q15	5	8288832	2-P13	5	8295634	2-P15
19	8280721	2-Q11	2	8283053	2-S12	16	8285707	2-Q15	6	8288832	2-P16	22	8295647	2-Q14
10	8280723	2-Q15	2	8283053	2-S11	10	8285707	2-Q12	2	8288832	2-R16	7	8295648	2-Q15
22	8280723	2-Q11	6	8283232	2-Q5	17	8285709	2-Q15	1	8288832	2-S15	5	8295650	2-Q15
2	8280745	2-R12	7	8283233	2-Q5	3	8286438	2-S12	2	8288832	2-S14	4	8295652	2-Q15
1	8280835	2-R13	8	8283234	2-Q5	3	8286438	2-S11	5	8288986	2-P6	6	8295731	2-P15
1	8280835	2-R16	9	8283258	2-Q5	4	8287193	2-S12	6	8288988	2-P6	4	8295865	2-R8
1	8280835	2-R17	4	8283258	2-Q3	4	8287193	2-S11	3	8289428	2-P11	43	8295960	2-R11
1	8280835	2-S14	3	8283325	2-Q8	4	8287304	2-R10	5	8289428	2-Q8	5	8295964	2-R8

ITEM	PART N.	GRID	ITEM	PART N.	GRID	ITEM	PART N.	GRID	ITEM	PART N.	GRID	ITEM	PART N.	GRID
5	4812091	1-P11	5	4952553	2-T8	2	4967710	2-I10	5	4982644	1-I2	8	4998870	1-I9
7	4813370	1-P4	4	4954336	2-S5	2	4967710	2-I8	19	4982768	2-L4	1	5110478	2-M12
6	4813442	1-P9	3	4955390	3-H13	1	4967724	2-H14	1	4983297	3-H13	1	5110478	2-M11
11	4813541	1-P11	1	4955605	2-M5	1	4967724	2-N16	3	4983464	2-I6	19	5120204	2-M11
2	4813566	1-O15	10	4955605	2-M2	2	4967729	2-I6	20	4983613	2-L4	16	5120206	2-M11
5	4817522	1-O15	6	4957531	2-T8	17	4968342	2-L4	13	4983643	2-M8	4	5120207	2-M11
11	4824221	1-I12	7	4958134	2-L4	5	4968964	2-L11	3	4983695	3-I16	1	5120481	2-I115
22	4824416	1-I12	8	4958138	2-L4	6	4968965	2-L11	4	4983697	3-I16	12	5120484	2-M11
7	4829218	1-P9	9	4958139	2-L4	7	4968968	2-L11	3	4984517	1-L7	4	7302756	1-P9
27	4838844	1-I12	10	4958144	2-L4	8	4968969	2-L11	4	4984525	1-L7	4	7302776	1-P9
5	4845138	1-H7	4	4959324	1-O6	1	4969925	2-M17	5	4984549	1-L7	3	8268534	2-L9
6	4848560	1-O2	3	4962641	1-L14	18	4970225	2-L4	6	4984550	1-L7	2	8268534	2-P8
6	4848840	1-P3	2	4962642	1-L14	2	4970504	1-L7	2	4984830	2-I13	26	8270124	2-P15
19	4854715	1-P2	4	4965705	2-L11	1	4970504	2-H12	2	4985147	2-L6	1	8270124	2-Q15
2	4858073	1-P3	1	4965705	2-L12	4	4971518	2-L10	1	4985147	2-L7	1	8270124	2-Q12
2	4858074	1-P8	1	4965705	2-M3	1	4971716	2-M4	2	4985147	2-R3	2	8270126	2-Q12
2	4858074	1-P0	1	4966230	2-L9	2	4971717	2-M4	1	4985147	2-R4	1	8270126	2-Q5
2	4858082	1-H12	1	4966618	1-I2	3	4971719	2-M4	3	4985332	2-I13	1	8270126	2-Q3
4	4858082	2-M15	11	4966833	2-L4	3	4971720	2-M4	3	4985332	2-L6	2	8273439	2-H10
1	4858082	2-N11	12	4966912	2-L4	3	4971721	2-M4	14	4985332	2-L7	2	8273909	2-M12
7	4858083	1-O11	13	4966917	2-L4	2	4971843	1-I2	?	4986079	2-M16	2	8273909	2-M11
1	4858085	1-L8	14	4966918	2-L4	2	4973384	3-H17	3	4986080	2-I16	3	8273911	2-M12
1	4858086	1-L17	15	4966929	2-L4	2	4976140	2-L9	2	4986258	2-R8	3	8273911	2-M11
1	4858087	1-P7	2	4967079	2-L12	3	4976532	2-R5	3	4986261	2-R8	4	8273912	2-M12
1	4858089	1-P10	2	4967197	2-R5	8	4976733	1-I10	7	4986988	1-L7	5	8273915	2-M12
7	4858091	2-M15	16	4967633	2-L4	1	4977072	2-I13	8	4989767	1-L7	9	8273916	1-H13
7	4858091	2-N11	1	4967635	1-L3	3	4977118	1-I2	1	4990617	1-L13	3	8273916	1-Q16
3	4858092	1-I4	1	4967635	1-L5	4	4977122	1-I2	2	4990624	1-L10	1	8273916	1-Q14
2	4859907	1-P6	2	4967704	3-I16	1	4980338	1-L10	1	4991458	3-L6	3	8273916	1-Q12
3	4859908	1-P6	2	4967707	2-I10	4	4980622	3-H11	1	4991458	3-L7	3	8273916	1-S6
3	4950259	2-S5	2	4967707	2-I8	2	4980622	3-H13	4	4992038	2-R5	1	8273916	1-S4
2	4950745	1-L8	2	4967708	2-I10	5	4981746	3-H11	5	4995683	2-S5	3	8273916	1-S2
3	4951417	2-L10	2	4967708	2-I8	3	4981746	3-H13	5	4997139	2-L10	6	8273916	2-M12
3	4951845	1-L8	2	4967709	2-I10	1	4982020	3-I3	6	4997141	2-L10	7	8273917	2-M12
1	4952067	3-I16	2	4967709	2-I8	15	4982514	2-N16	9	4998870	1-I10	8	8273918	2-M12

ITEM	PART N.	GRID	ITEM	PART N.	GRID	ITEM	PART N.	GRID	ITEM	PART N.	GRID	ITEM	PART N.	GRID
6	4753555	1-L15	15	4764170	1-L17	6	4770265	1-O2	5	4783241	1-H7	2	4796457	1-H7
8	4753563	1-O15	2	4764724	1-M13	6	4770435	1-P3	3	4784008	1-P8	5	4797577	1-M13
10	4754028	1-H9	1	4764725	1-M8	30	4770452	1-I17	7	4784078	1-P8	4	4797579	1-M13
5	4754069	1-H6	6	4764863	1-P11	9	4770452	1-I4	11	4784432	2-N11	1	4797619	1-H2
9	4754492	1-O15	16	4764887	1-L17	17	4770455	1-I12	7	4784454	1-P4	7	4798844	1-I4
11	4754629	1-L16	13	4764904	1-H13	6	4770614	1-P8	3	4784788	1-P7	1	4798845	1-P6
12	4754630	1-L16	17	4765047	1-L17	3	4770623	1-H6	2	4784790	1-P7	3	4799016	1-M15
13	4754631	1-L16	18	4765266	1-L17	3	4770624	1-H6	4	4784793	1-P10	4	4799060	1-M15
14	4754632	1-L16	7	4765344	1-P11	1	4770651	1-I17	16	4784889	1-I12	4	4799061	1-I4
15	4754633	1-L16	8	4765345	1-P11	3	4770859	1-H7	15	4785107	1-H14	5	4799086	1-M15
16	4754634	1-L16	9	4765346	1-P11	2	4771242	2-N11	4	4785501	1-O11	16	4799275	1-O14
1	4754671	1-I7	10	4765347	1-P11	5	4772142	1-H12	9	4786900	1-O15	6	4799342	1-M15
8	4756251	1-H13	7	4765364	1-H11	2	4772229	1-P11	11	4786937	1-I12	11	4799587	1-O7
5	4756657	2-S4	7	4765364	1-H12	3	4772231	1-P11	10	4787154	1-H9	9	4800030	1-M12
2	4757193	2-S3	8	4765392	1-O2	6	4773064	1-O11	5	4788084	2-N11	4	4800147	1-P3
4	4757575	1-P10	4	4765449	1-I3	3	4773265	1-O11	3	4788086	1-N11	13	4800841	1-O15
6	4757576	1-O10	11	4765504	1-P11	5	4774405	1-P3	6	4788908	1-I4	16	4800842	1-O14
2	4757577	1-P7	6	4766126	1-H12	2	4774408	1-I6	8	4788909	1-I4	17	4800844	1-O14
3	4757617	1-P7	15	4766404	1-I17	4	4774892	1-I3	7	4789860	1-M14	3	4801610	1-P9
6	4757884	1-M13	3	4769412	1-I15	1	4776544	1-O15	15	4790861	1-M13	20	4802126	1-I12
1	4757884	1-M10	4	4769414	1-I15	4	4776650	1-M14	5	4790882	1-O2	20	4802127	1-I12
2	4758240	1-I7	9	4769416	1-I15	6	4779122	1-H14	8	4791124	1-M12	2	4802392	1-M12
3	4758240	1-I6	1	4769418	1-I15	13	4779685	1-I11	24	4791125	1-M14	3	4802395	1-M12
5	4758241	1-P11	6	4769419	1-I15	23	4780108	1-I12	2	4791332	1-M15	20	4805683	1-H14
7	4758943	1-L15	2	4769420	1-I15	6	4780558	1-I12	5	4792039	1-H15	4	4806010	1-I6
14	4758953	1-L17	14	4769427	1-I4	24	4780559	1-I12	6	4792169	1-H6	9	4806131	1-H9
9	4760284	1-H5	3	4769429	1-I4	1	4780612	1-M12	9	4792661	1-M14	1	4806133	1-I6
9	4760284	1-H7	2	4769710	1-I4	29	4780624	1-I17	10	4792662	1-M14	25	4806611	1-M14
17	4760285	1-L16	2	4769877	1-I3	26	4780627	1-I17	11	4792663	1-M14	8	4807379	2-S9
4	4760312	1-P7	9	4770250	1-O11	3	4781578	1-H12	12	4792664	1-M14	7	4807436	1-M15
3	4760486	1-I7	9	4770253	1-O7	4	4781579	1-H12	13	4792665	1-M14	2	4808519	2-S3
29	4762000	1-H17	6	4770254	1-O7	2	4782453	1-O11	14	4792666	1-M14	8	4809173	1-H6
6	4763099	1-O9	5	4770255	1-H14	5	4782785	1-H9	7	4795702	1-O2	7	4809354	1-P11
10	4763523	1-H5	3	4770259	1-O7	6	4782786	1-H9	8	4795704	1-O2	1	4809425	1-I4
10	4763523	1-H7	5	4770262	1-O7	8	4782867	1-H7	11	4795708	1-P11	8	4809524	1-I15

ITEM	PART N.	GRID	ITEM	PART N.	GRID	ITEM	PART N.	GRID	ITEM	PART N.	GRID	ITEM	PART N.	GRID
3	4641873	1	24	4673610	1-H13	29	4690506	1-H13	23	4706866	1-H16	3	4727848	2-H17
4	4641874	1-L1	5	4673807	1-P3	29	4690506	1-H12	5	4706879	1-P8	4	4727849	2-H17
5	4642050	1-H11	6	4673810	1-P3	29	4690507	1-H13	4	4706880	1-P8	5	4727975	1-O2
1	4643544	2-S4	3	4679201	1-H4	29	4690507	1-H11	5	4707725	1-H16	6	4728639	1-O2
5	4647815	1-L16	3	4679202	1-H4	29	4690508	1-H13	5	4707726	1-H16	5	4728716	1-H15
20	4648421	1-H4	1	4679221	1-H16	29	4690508	1-H11	5	4707727	1-H16	8	4730553	1-H9
20	4648422	1-H4	2	4679224	1-H16	7	4695922	1-H5	5	4707728	1-H16	6	4730554	1-O15
3	4653282	1-H9	3	4679226	1-H16	7	4695922	1-H7	5	4707729	1-H16	7	4730555	1-O15
4	4653283	1-H9	4	4679227	1-H16	26	4695923	1-H8	11	4708213	1-I4	1	4731044	1-H2
4	4653346	1-O10	7	4679242	1-P3	5	4696355	1-H4	6	4710517	1-H4	12	4731816	1-O12
7	4655011	1-P8	5	4679272	1-H16	16	4696722	1-H16	7	4710518	1-H4	13	4731819	1-O12
3	4655844	1-H15	8	4680071	1-H16	4	4697838	1-P3	5	4713071	1-H9	7	4733736	1-O2
5	4655844	1-H16	1	4680577	1-H13	17	4698677	1-H16	6	4713072	1-H9	7	4738345	1-H13
5	4655844	1-H15	25	4681251	1-H13	17	4698679	1-H16	7	4717026	1-I6	7	4738347	1-H13
4	4655847	1-H15	25	4681251	1-H12	17	4698680	1-H16	9	4717654	1-L16	7	4738348	1-H13
9	4659217	1-L17	26	4682937	1-H13	17	4698681	1-H16	6	4717677	1-H10	7	4738349	1-H13
1	4659217	1-M13	26	4682937	1-H12	17	4698682	1-H16	6	4717677	1-I9	7	4738350	1-H13
10	4659218	1-L17	27	4683070	1-H13	3	4698683	1-H13	7	4717707	1-H10	10	4739148	1-L16
14	4659218	1-M13	27	4683070	1-H12	3	4698685	1-H13	7	4717707	1-I9	12	4739213	1-O11
11	4659219	1-L17	28	4684422	1-H13	3	4698686	1-H13	12	4718621	1-H14	8	4739309	1-H5
3	4659219	1-M13	6	4689110	1-L16	3	4698687	1-H13	7	4718740	1-H9	8	4740097	1-H4
2	4661543	1-O2	7	4689111	1-L16	3	4698688	1-H13	10	4719705	1-O12	13	4741072	1-L17
4	4663081	1-O15	2	4690226	1-H13	8	4699153	1-L16	10	4719705	1-O11	4	4742848	1-M9
2	4665029	1-H4	29	4690352	1-H13	3	4699155	1-O2	11	4719706	1-O12	2	4744740	2-S4
2	4665029	1-H6	29	4690352	1-H12	9	4699371	1-O12	11	4719706	1-O11	3	4744741	2-S4
6	4667450	1-H16	3	4690496	1-H16	9	4699372	1-O7	5	4723150	1-O15	4	4744845	2-S4
7	4667451	1-H16	3	4690497	1-H16	33	4699783	1-H13	12	4724015	1-L17	9	4745364	1-H9
11	4667452	1-H15	3	4690498	1-H16	33	4699783	1-H11	1	4724223	1-P10	9	4746023	1-H16
10	4667452	2-M15	3	4690499	1-H16	4	4699805	1-H13	2	4724224	1-P10	2	4747161	1-P11
10	4667452	2-N11	3	4690500	1-H16	4	4699806	1-H13	3	4724553	1-P10	3	4747163	1-P11
6	4667498	1-I5	4	4690501	1-H16	5	4699807	1-H13	5	4724554	1-O10	4	4747164	1-P11
5	4667498	1-I4	4	4690502	1-H16	5	4699808	1-H13	2	4724739	1-I3	7	4751087	1-I5
6	4673192	1-H11	4	4690503	1-H16	6	4703073	1-H13	1	4724814	1-P7	8	4751088	1-I5
22	4673608	1-H4	4	4690504	1-H16	4	4703088	1-O2	3	4725351	1-I3	9	4751089	1-I5
23	4673609	1-H4	4	4690505	1-H16	25	4704106	1-H14	1	4727187	2-H17	11	4751151	2-M15

ITEM	PART N.	GRID	ITEM	PART N.	GRID	ITEM	PART N.	GRID	ITEM	PART N.	GRID	ITEM	PART N.	GRID
1	775594	1-N12	1	4031577	1-H11	1	4589429	1-I9	12	4603448	1-I14	5	4613293	1-O7
1	775595	1-N12	1	4031577	1-H12	2	4592280	1-L16	22	4603449	1-H6	4	4613297	1-I10
1	775596	1-N12	3	4057844	3-H11	34	4592280	1-M17	13	4603449	1-I14	4	4613297	1-I9
1	775597	1-N12	2	4073976	2-S9	3	4598124	1-O12	23	4603450	1-H6	6	4613351	1-O7
1	775598	1-N12	3	4073977	2-S9	7	4599398	1-I14	14	4603450	1-I14	7	4613352	1-O7
1	775599	1-N12	1	4094290	2-T8	7	4599398	1-I12	20	4603451	1-H6	8	4613353	1-O7
1	775600	1-N12	2	4151244	2-T8	1	4599557	1-P6	15	4603451	1-I14	5	4614111	1-O12
1	775601	1-N12	1	4177981	2-R12	1	4599557	1-P9	3	4603862	1-P8	4	4615459	1-P3
1	1901385	1-H14	3	4182461	2-T8	2	4599560	1-P8	4	4603870	1-P8	5	4617226	1-I10
1	1901386	1-H14	1	4182461	3-H15	2	4599561	1-P3	2	4604833	1-I5	5	4617226	1-I9
1	1901387	1-H14	4	4182462	2-T8	3	4599562	1-P3	3	4605293	1-I10	6	4617481	1-O12
1	1901388	1-H14	2	4231247	1-I14	1	4599607	1-H4	3	4605293	1-I9	7	4617482	1-O12
31	1901609	1-H17	1	4232606	1-H5	1	4599607	1-H6	1	4605564	1-H9	7	4617482	1-O11
12	1901803	1-H13	6	4232606	1-H7	2	4599726	1-I10	17	4605853	1-P4	7	4618309	1-L17
12	1901804	1-H13	1	4238805	3-H6	2	4599726	1-I9	8	4605854	1-I6	7	4619405	2-M15
12	1901805	1-H13	2	4262887	1-O12	1	4599807	1-I16	3	4607511	1-I16	7	4619405	2-N11
31	1909234	1-H17	1	4293094	3-L17	1	4599809	1-O2	2	4607582	2-M15	8	4621358	2-M15
31	1909242	1-H17	1	4318965	1-P11	1	4600128	2-S9	3	4607586	2-M15	16	4621511	1-I14
7	1930176	1-H14	3	4338920	1-I14	1	4600189	1-H15	2	4607590	1-H11	17	4622850	1-I14
7	1930177	1-H14	3	4338920	1-I12	2	4600190	1-H15	2	4607590	1-H12	8	4623038	1-L17
7	1930178	1-H14	2	4360198	2-S5	2	4600329	1-I16	4	4607590	2-M15	18	4625173	1-I14
7	1930179	1-H14	19	4479391	2-T3	1	4600893	1-I3	1	4607590	2-N11	18	4625173	1-I12
7	1930180	1-H14	1	4543282	1-L16	3	4601061	1-H5	5	4607593	2-M15	1	4626467	1-M9
16	1930181	1-I17	6	4551493	1-L17	8	4601295	1-I14	3	4607638	1-H11	2	4626468	1-M9
16	1930182	1-I17	1	4564844	1-M15	8	4601295	1-I12	4	4607639	1-H11	6	4628453	1-H5
16	1930183	1-I17	4	4570798	1-I14	9	4601296	1-I14	3	4607663	1-I5	9	4630543	2-M15
16	1930184	1-I17	4	4570798	1-I12	9	4601296	1-I12	4	4607665	1-I5	8	4630787	1-O12
16	1930185	1-I17	4	4570799	1-I14	10	4601302	1-I14	4	4607670	1-O12	8	4630787	1-O11
2	1930186	1-I17	4	4570799	1-I12	4	4601390	1-H5	4	4607743	1-I16	1	4632108	1-L8
2	1930188	1-I17	6	4578175	1-I14	1	4601827	1-O15	2	4607786	1-H9	5	4639096	1-P8
2	1930190	1-I17	2	4585990	1-H5	1	4601834	1-I5	3	4607792	1-O10	6	4639097	1-P8
3	1930191	1-I17	2	4585990	1-O10	2	4601981	1-O15	5	4608451	1-H5	19	4639661	1-I14
3	1930193	1-I17	1	4587730	1-O7	3	4602270	1-O15	6	4609538	2-M15	19	4639661	1-I12
3	1930195	1-I17	2	4587731	1-O7	11	4603190	1-I14	3	4613290	1-O7	5	4640558	1-I5
5	4002890	1-L17	1	4589429	1-I10	21	4603448	1-H6	4	4613292	1-O7	3	4640764	1-M9

ITEM	PART N.	GRID	ITEM	PART N.	GRID	ITEM	PART N.	GRID	ITEM	PART N.	GRID	ITEM	PART N.	GRID
15	759073	1-O17	24	765067	1-M5	7	766838	1-N10	8	771065	1-M16	11	773144	1-N8
16	759074	1-O17	24	765068	1-M5	8	766839	1-N10	9	771066	1-M16	11	773145	1-N8
7	759146	1-N5	24	765069	1-M5	34	767023	1-M4	28	771078	1-M6	11	773146	1-N8
16	759242	1-M7	24	765070	1-M4	2	767107	1-M16	10	771326	1-M16	11	773147	1-N8
4	759850	1-L17	24	765071	1-M4	9	767110	1-N10	5	771326	1-M12	11	773148	1-N8
17	760157	1-O17	4	765103	1-N10	10	767112	1-N10	22	771463	1-N5	11	773149	1-N8
6	760203	1-N4	7	765256	1-N7	11	767314	1-N4	24	771468	1-N5	11	773150	1-N8
11	760239	1-M11	21	765290	1-O17	12	767315	1-N4	25	771469	1-N5	11	773151	1-N8
12	760241	1-M11	22	765291	1-O17	1	767373	1-L15	26	771470	1-N5	11	773152	1-N9
18	760356	1-M5	30	765304	1-M4	1	767374	1-L15	27	771471	1-N5	21	773242	1-N9
19	760463	1-M5	31	765306	1-M4	11	767451	1-N10	5	771646	1-L15	22	773280	1-N9
20	760489	1-M5	9	765342	1-N4	3	767893	1-L15	18	771647	1-N4	23	773281	1-N9
7	760666	1-N4	32	765461	1-M4	18	767977	1-N5	15	771702	1-N4	1	775013	1-N11
21	760862	1-M5	13	765505	1-N5	19	767980	1-N5	2	772051	1-N12	1	775014	1-N11
8	760925	1-N5	14	765504	1-N5	20	767981	1-N5	2	772051	1-N14	1	775015	1-N11
9	760926	1-N5	15	765505	1-N5	21	767982	1-N5	21	772370	1-M7	1	775016	1-N11
13	763178	1-M11	16	765632	1-N5	24	768043	1-M7	22	772379	1-M7	1	775017	1-N11
5	763187	1-N7	1	765640	1-M16	13	768043	1-N4	23	772381	1-M7	1	775018	1-N11
10	763235	1-N5	19	765758	1-M7	32	768069	1-O16	1	772799	1-N11	1	775019	1-N11
11	763236	1-N5	10	766075	1-N4	9	768161	1-N7	1	772800	1-N11	1	775025	1-N11
12	763432	1-N5	6	766093	1-O17	12	768378	1-N10	1	772801	1-N11	1	775026	1-N11
8	763440	1-N4	6	766094	1-O17	25	768482	1-M7	1	772802	1-N11	1	775027	1-N11
18	763638	1-O17	6	766095	1-O17	10	768757	1-N7	1	772803	1-N11	1	775028	1-N11
19	763714	1-O17	6	766096	1-O17	11	768950	1-N7	1	772804	1-N11	1	775029	1-N11
20	763754	1-O17	5	766193	1-N10	26	769236	1-M7	1	772805	1-N11	1	775030	1-N11
14	764120	1-M11	20	766250	1-M7	14	769357	1-N4	1	773102	1-N8	1	775031	1-N11
17	764155	1-M7	27	766298	1-O17	16	769378	1-N4	2	773118	1-N8	1	775032	1-N11
6	764582	1-N7	28	766299	1-O16	17	769542	1-N4	3	773120	1-N8	1	775113	1-N11
15	764956	1-M11	29	766300	1-O16	3	770578	1-M16	4	773129	1-N8	1	775116	1-N11
16	764957	1-M11	33	766419	1-M4	27	770784	1-M7	5	773131	1-N8	1	775146	1-N11
17	764958	1-M11	17	766432	1-N5	35	770785	1-M4	5	773132	1-N8	1	775589	1-N12
18	764995	1-M7	30	766642	1-O16	4	770899	1-M16	5	773133	1-N8	1	775590	1-N12
22	765057	1-M5	31	766645	1-O16	5	770902	1-M16	9	773139	1-N8	1	775591	1-N12
23	765065	1-M5	8	766662	1-N7	6	770958	1-M16	10	773140	1-N8	1	775592	1-N12
24	765066	1-M5	6	766837	1-N10	7	770959	1-M16	11	773143	1-N8	1	775593	1-N12

ITEM	PART N.	GRID	ITEM	PART N.	GRID	ITEM	PART N.	GRID	ITEM	PART N.	GRID	ITEM	PART N.	GRID
1	14687	2-L11	2	584747	2-N14	2	591693	3-H11	2	706210	1-O17	9	747568	1-M7
1	15480	2-L6	1	586707	2-L4	5	592437	3-H13	23	722023	1-N4	10	748670	1-M5
9	15480	2-L7	2	586707	2-L14	1	592915	2-I10	1	722023	1-N5	9	751032	1-M11
19	15629	2-L10	2	586750	2-L11	2	592934	2-L10	2	722027	1-N10	11	751627	1-M5
1	546575	2-L13	2	587138	2-M8	4	593738	1-L14	2	722282	1-N5	5	752758	1-O17
1	546575	2-L14	3	587141	2-M8	4	594633	2-M2	3	722283	1-N5	10	753177	1-M7
2	549537	3-H13	4	587142	2-M8	5	594634	2-M2	3	722353	1-O17	3	753177	1-N4
1	552699	2-S5	24	587155	2-M8	6	594637	2-M2	4	723838	1-N5	5	753177	1-N5
1	555486	3-H11	4	587158	2-M10	7	594638	2-M2	4	723857	1-O17	4	753195	1-N4
1	555486	3-H13	1	587271	2-M2	8	594640	2-M2	4	726380	1-M7	10	753762	1-M11
1	561293	1-O12	2	587272	2-M2	1	595208	2-S9	5	726381	1-M7	12	754799	1-M5
1	561293	1-O11	3	587273	2-M2	1	595582	2-P8	1	726381	1-N4	13	755708	1-M5
1	561353	1-L17	2	587394	2-L13	9	595736	2-M8	3	726381	1-N10	14	755860	1-M5
1	562515	1-L14	3	587406	2-L13	9	595878	2-M10	1	739124	2-I6	15	756190	1-M5
1	563024	2-N3	4	587408	2-L13	9	596096	2-M2	1	739124	2-I4	16	756191	1-M5
1	563652	1-I14	3	587409	2-L14	1	596152	1-P3	3	740314	1-L17	11	756200	1-M7
1	563652	1-I12	1	587468	1-L7	3	597258	2-L11	1	741569	1-O6	12	756201	1-M7
12	564530	2-M11	2	589320	2-L4	4	597768	2-L4	2	741570	1-O6	13	756202	1-M7
1	567406	2-L10	3	590523	2-L4	2	597869	2-N5	3	741571	1-O6	14	756203	1-M7
1	567406	2-P13	1	590523	2-R3	15	598816	1-I10	5	746152	1-M11	5	757354	1-N4
1	567406	2-P16	5	591105	2-M10	5	599305	2-L4	6	746152	1-M7	2	757357	1-N7
1	567406	2-P17	5	591107	2-M8	6	599307	2-L4	6	746153	1-M11	15	758065	1-M7
1	567406	3-H17	1	591107	2-R10	24	599777	1-O11	7	746189	1-M11	17	758707	1-M5
1	575874	2-M10	6	591108	2-M10	10	599820	2-M8	8	746214	1-M11	6	758880	1-O17
1	575888	2-M8	7	591112	2-M10	2	607942	1-L17	7	746366	1-M7	6	758881	1-O17
1	581492	2-L15	6	591115	2-M8	1	656829	1-N10	2	746368	1-M5	6	758882	1-O17
1	581492	2-R5	7	591121	2-M8	1	705633	1-M11	3	746370	1-M5	6	758883	1-O17
1	581610	2-M15	8	591123	2-M8	2	705636	1-M11	4	746371	1-M5	6	758884	1-O17
2	581658	2-M10	11	591125	2-M8	3	705637	1-M11	5	746373	1-M5	6	758885	1-O17
1	581658	2-N5	25	591217	2-M8	1	705726	1-O17	6	746374	1-M5	6	758886	1-O17
1	581658	2-N14	8	591247	2-M10	1	705736	1-M7	7	746379	1-M5	6	758887	1-O17
1	581658	2-R8	20	591413	2-L14	4	705737	1-M11	8	746380	1-M5	6	758888	1-O17
3	581967	2-M10	2	591420	2-L3	2	705737	1-M7	9	746399	1-M5	6	759016	1-N5
3	582081	3-H13	6	591420	2-L13	1	705816	1-M5	8	746993	1-M7	3	759041	1-N7
1	584009	2-L3	1	591420	3-L14	1	706197	1-N7	2	747210	1-N4	4	759046	1-N7

30.1065.01.1	E3.02/6 - E3.32/3	TILT CYLINDER - CILINDRO TILT - VERIN DE TILT - TILT ZYLINDER - CILINDRO TILT
30.1070.09.1	E3.02/7 - E3.32/4	TILT CYLINDER - CILINDRO TILT - VERIN DE TILT - TILT ZYLINDER - CILINDRO TILT
30.1095.07.1	E3.10/4	REINFORCEMENTS - MENSOLE - CONSOLES - STUETZEN - REFUERZOS
30.1107.01.1	E3.02/12	QUICK RELEASE VALVE - VALVOLA DISCESA RAPIDA - SOUPAPE DESCENTE RAPIDE - SCHNELLENSENKVENTIL - VALVULA DE DESCENSO RAPIDO
30.1124.05.1	E3.02/8 - E3.10/6 - E3.32/5	HYDRAULIC TILT CONTROL - TILT IDRAULICO - TILT HYDRAULIQUE - HYDRAULIK QUERNEIGUNG - TILT HIDRAULICO
30.1280.05.1	E3.02/3	LINE FROM DIVERTOR VALVE TO REAR EQUIPMENT - TUBAZIONE DAL DEVIATORE ALL'ATTREZZO POSTERIORE - TUYAUTERIE DU DEVIATEUR A L'OUTIL POSTERIEUR - LEITUNG VOM WECHSELSCHALTVENTIL ZUR HECK-AUSRUSTUNG - TUBERIA DEL DISTRIBUIDOR A L'UTIL POSTERIOR
30.1281.01.1	E3.02/4	LINE FROM DISTRIBUTOR VALVE TO REAR EQUIPMENT - TUBAZIONE DAL DISTRIBUTORE ALL'ATTREZZO POSTERIORE - TUYAUTERIE DU DISTRIBUTEUR A L'OUTIL POSTERIEUR - LEITUNGEN VOM STEVERBLOCK ZUM HINTEREN ARBEITSGERAT - TUBERIA DEL DISTRIBUIDOR A L'UTIL POSTERIOR
30.9040.01.1	M1.02	GERMAN VERSION - ALLESTIMENTO GERMANIA - EQUIPMENT ALLEMAGNE - AUSRUSTUNG FUR DEUTSCHLAND - TIPO ALEMANIA
30.9116.08.1 D 3212 VII-1990	F4.01 - L1.30/1	FANA VERSION - ALLESTIMENTO FANA - VARIANTE POUR AMERIQUE DU NORD - VERSION FUER NORDAMERICA - VERSION PARA NORTEAMERICA

	DESIGNAZIONE BASE	BASIC DESIGNATION	DESIGNATIONS-BASES	GRUNDBEZEICHNUNGEN	DENOMINACIONES BASE
41M	MANOMETRO ARIA	AIR PRESSURE GAUGE	MANOMETRE AIR	LUFTDRUCKMESSER	MANOMETRO DE AIRE
42A	ANELLO RASCHIAFANGO	MUDSCRAPER RING	GARNITURE PARE-BOUE	SCHLAMMKRATZRING	RETENDOR DE BARRO
42A					
42F	FENDINEBBIA	FOG LAMP	FEU BROUILLARD	NEBELSCHEINWERFER	PROYECTOR ANTINEBLA
42M	MANOMETRO OLIO	OIL PRESSURE GAUGE	MANOMETRE HUILE	OELDRUCKMESSER	MANOMETRO ACEITE
42P	PASTIGLIA FRENO	BRAKE LINING	PASTILLE DE FREIN	BREMSBELAG	PASTILLA DE FRENO
42R	RADIO	RADIO	RADIO	RUNDFUNK	RADIO
42V	VITE SENZA FINE	WORM SCREW	VIS SANS-FIN	SCHNECKE	TORNILLO SIN FIN
43R	RETICELLA DEL FILTRO	FILTER STRAINER	CREPINE	FILTER SIEB	REDECILLA
44D	DIFFUSORE ARIA ORIENTABILE	ADJUSTABLE AIR OUTLET	AERATEUR ORIENTABLE	VERSTELLBARE LUFTDUESE	BOQUILLA ORIENTABLE
44D					
44R	RETE	NET	GRILLE	NETZ	REJILLA
44V	VITE CON ROSETTA	SCREW AND WASHER ASSY	VIS AVEC RONDELLE	SCHRAUBE MIT SCHEIBE	TORNILLO CON ARANDELA
44V					
443	DIFFERENZIALE AUTOBLOCCANTE	SELF-LOCKING DIFFERENTIAL	DIFFERENTIEL (NO-SPIN)	DIFFERENTIAL (NO-SPIN)	DIFERENCIAL (NO-SPIN)
445	DISP. DISINNESTO ASSALE POST	REAR AXLE DISCONNECT	DISPOSITIF DECLAPOTAGE PONT AR	HINTERACHSABSCHLTUNG	DISPOSITIVO DESACOPLO EJE POSTARO
45A	ANELLO	RING	BAGUE	RING	ARO
45C	CAMPANA	BELL HOUSING	CLOCHE	GEHAUSE	CAMPANA
45D	DIFFUSORE	DIFFUSER	DIFFUSEUR	LUFTDUESE	DIFUSOR
45F	FERMAGLIO	CLIP	FERMOIR	KLEMMSTUECK	SUJETADOR
45L	LEVA	LEVER	LEVIER	HEBEL	PALANCA
45M	MANOVELLA PER RUOTE	SPEED HANDLE FOR WHEELS	MANIVELLE DE ROUES	RADBOLZEN-SCHLUESSEL	BERBIQUI PARA RUEDAS
45M					
45P	PATTINO	PAD	PATIN	GLEITBLOCK	PATIN
46A	ANELLO REGGISPINTA	THRUST RING	RONDELLE DE BUTEE	DRUCKSCHEIBE	ANILLO DE APOYO
46D	DIFFUSORE VENTURI	CHOKE	CONDUIT VENTURI	ANSAUGTRICHTER	DIFUSOR VENTURI
46E	ESPANSIONE POLARE	POLE SHOE	MASSE POLARE	POLSCHUH	PIEZA POLAR
47A	ANELLO FRIZIONE	FRICTION RING	GARNITURE	KUPPLUNGSBELAG	FORRO
47V	VOLANO	FLYWHEEL	VOLANT	SCHWINGMASSE	VOLANTE
48A	ANELLO DI GOMMA	RUBBER RING	BAGUE CAOUTCHOUC	GUMMIRING	GUARNICION DE CAUCHO
48A					
48V	VOLANO	FLYWHEEL	VOLANT	SCHWUNGRAD	VOLANTE MOTOR
49A	ANELLO ISOLANTE	INSULATING RING	BAGUE ISOLANTE	ISOLIERRING	ANILLO AISLADOR
490	DISP. GONFIAGGIO PNEUM.	TYRE INFLATOR	APPAREIL DE GONFLAGE DE PNEU	REIFENFUELLANLAGE	ACESCRIO PARA INFLAR NEUMATICOS
50A	ANELLO RASCHIAOLIO	OILSCRAPER RING	SEGMENT RACLEUR	OELABSTREIFRING	ARO DE ENGRASE
50B	BIELLA	LINK	BIELLE	PLEUELSTANGE	BIELA
50C	CANALE	CHANNEL	PROFILE	SCHIENE	CANAL
50D	DINAMO	GENERATOR	DYNAMO	LICHTMASCHINE	DINAMO
50E	ESTENDBLOC	ESTENDBLOC	ESTENDBLOC	ESTENDBLOC	ESTENDBLOC
50F	FIANCATA	SIDE FRAME	COTE DE COQUE	SEITENWAND	COSTADO

DESIGNAZIONE BASE	BASIC DESIGNATION	DESIGNATIONS-BASES	GRUNDBEZEICHNUNGEN	DENOMINACIONES BASE
34S	SEMISCATOLA	HALF CASE	DEMI-CARTER	SEMICAJA
35B	BENNA	BUCKET	GODET	CUCHARA
35C	CAMICIA	CYLINDER	CHEMISE	CAMISA
35D	DIAFRAMMA	DIAPHRAGM	DIAPHRAGME	DIAFRAGMA
35G	GENERATORE DI CORRENTE	CURRENT GENERATOR	GENERATEUR DE COURANT	GENERADOR DE CORRIENTE
35I	INDICATORE	INDICATOR	INDICATEUR	INDICADOR
35L	LAMPEGGIATORE	FLASHER	CLIGNOTANT	RELAMPAGUEANTE
35R	REOSTATO	RHEOSTAT	RHEOSTAT	REOSTATO
35S	SCATOLA	CASE	CARTER	CAJA
36A	AMMORTIZZATORE	SHOCK ABSORBER	AMORTISSEUR	AMORTIGUADOR
36I	INDICATORE DI TENSIONE	TENSION INDICATOR	INDICATEUR DE TENSION	INDICADOR DE TENSION
36P	PARAURTI	BUMPER	PARE-CHOC	PARIACHOQUES
36R	RECIPIENTE	CAN	RESERVOIR	DEPOSITO
36S	SCATOLA GUIDA	STEERING HOUSING	BOITIER DE DIRECTION	CAJA DE DIRECCION
36V	VENTOLA	BLOWER	SOUFFLERIE	AVENTADOR
37A	ADATTATORE	ADAPTER GEAR	ADAPTATEUR	ARENVIO DE REGULACION
37M	REGOLATORE DI TEMPERATURA	TEMPERATURE CONTROL	REGULATEUR DE TEMPERATURE	REGULADOR DE TEMPERATURA
37R	COMANDO COMBINATO FRENI-FRIZ	COMBINED STEERING-BRAKE CONTROL	COMMANDE COMBINEE FREINS-EMBR	BETAETLUNG LENKKUPPLUNG BREMS
38A	AMPEROMETRO	AMMETER	AMPEREMETRE	AMPERIMETRO
38L	LAVACRISTALLI	WINDSHIELD WASHER	ESSUI-GLACE	LAVA VIDRIOS
38R	REFRIGERATORE	COOLER	REFRIGERATEUR	REFRIGERADOR
38V	VETRO	PANEL OF GLASS	VITRE	VIDRIO
39A	ALTOPARLANTE	LOUDSPEAKER	HAUT-PARLEUR	ALTAVOZ
39P	PARATIA	BULKHEAD	CLOISON	TABIQUE
39R	RESISTORE	RESISTOR	RESISTEUR	RESISTOR
39S	SCATOLA DEL CUSCINETTO	BEARING CASE	CUVETTE DE ROULEMENT	CAJA DE RODAMIENTO
39S				
40A	ANCORA	ANCHOR	ANCRE	ANCLA
40C	CAMMA	CAM	CAME	LEVA
40D	DIFFERENZIALE	DIFFERENTIAL	DIFFERENTIEL	DIFERENCIAL
40G	GETTO	JET	GICLÉUR	SURTIDOR
40I	INDOTTO	ARMATURE	INDUIT	INDUCIDO
40M	MANOMETRO ACQUA	WATER PRESSURE GAUGE	MANOMETRE EAU	MANOMETRO AGUA
40P	PASSARUOTA	WHEELBOX	PASSE-ROUE	CAVIDAD DE RUEDA
40R	RESISTENZA	RESISTANCE	RESISTANCE	RESISTENCIA
40V	VITE	SCREW	VIS	TORNILLO

DESIGNAZIONE BASE	BASIC DESIGNATION	DESIGNATIONS-BASES	GRUNDBEZEICHNUNGEN	DENOMINACIONES BASE	
30S	SCARIFICATORE	SCARIFIER	SCAFIFICATEUR	AUFREISSER	ESCARIFICADOR
30T	TAPPETO	MAT	TAPIS	BODENMATTE	ALFOMBRA
30V	VENTILATORE	FAN	VENTILATEUR	LUEFTER	VENTILADOR
31A	ACCUMULATORE PRINCIPALE	MAIN ACCUMULATOR	ACCUMULATEUR PRINCIPAL	HAUPTBREMSSPEICHER	ACUMULADOR PRINCIPAL
31C	CAMBIO E DIFFERENZIALE	TRANSMISSION AND DIFFERENTIAL UNIT	BOITE ET DIFFERENTIAL	WECHSEL- U AUSGLEICHGETRIEBE	CAMBIO Y DIFERENCIAL
31D	DAL CAMBIO	FRJM TO TRANSMISSION	A PARTIR DE LA TRANSMISSION	AB WECHSELGETRIEBE	A PARTIR DEL CAMBIO
31E	ELETTROPOMPA	ELECTROPUMP	POMPE ELECTRIQUE	ELEKTRISCHE PUMPE	ELECTROBOMBA
31F	FASCETTA	CLAMP	COLLIER	HALTEBAND	ABRAZADERA
31G	GANCIO APPENDIBILE	HANGER	PORTE-MANTEAU	KLEIDERHAKEN	PERCHA
31I	INDICATORE LIVELLO	LEVEL GAUGE	INDICAT DE NIVEAU	STANDANZEIGER	INDICADOR DE NIVEL
31L	LAMPADA TRASPORTABILE	INSPECTION LAMP	LAMPE BALADEUSE	HANDLEUCHTE	LAMPARA DE INSPECCION
31O	OLIO	OIL	HUILE	OEL	ACEITE
31P	PARAFANGO	FENDER	AILE	KOTFLUEGEL	GUARDABARROS
31R	REGOLATORE DI TENSIONE	VOLTAGE REGULATOR	REGULATEUR DE TENSION	SPANNUNGSREGLER	REGULADOR DE TENSION
31R					
32C	CAMBIO E RIDUTTORE	TRANSMISSION AND REAR GEAR UNIT	BOITE DE VITESSES ET REDUCTEUR	WECHSEL U UNTERSATZUNGSGETRIEBE	CAMBIO Y REDUCTOR
32C					
32E	ELETTROVALVOLA	ELECTRIC VALVE	ELECTRO-VANNE	ELEKTROVENTIL	ELECTROVALVULA
32G	GANCIO DI TRAINO	TOW HOOK	CROCHET D'ATTACHE	ZUGHAKEN	ENGANCHE DE REMOLQUE
32I	INDICATORE ELETTRONICO	ELECTRONIC INDICATOR	INDICATEUR ELECTRONIQUE	ELEKTRONISCHER ANZEIGER	INDICADOR ELECTRONICO
32I					
32M	MANICOTTO DI REGOLAZIONE	ADJUSTMENT SLEEVE	MANCHON DE REGLAGE	SPANNSCHLOSS	TUERCA DE REGLAJE
32P	PARETE DIVISORIA	PARTITION PANEL	CLOISON	TRENNWAND	TABIQUE
32R	RADDRIZZATORE	RECTIFIER	REDRESSEUR	GLEICHRICHTER	RECTIFICADOR
33A	ACCUMULATORE IDRAULICO	HYDRAULIC ACCUMULATOR	ACCUMULATEUR HYDRAULIQUE	HYDRAUL DRUCKSPEICHER	ACUMULADOR HIDRAULICO
33C	CAMERA D'ARIA	INNER TUBE	CHAMBRE A AIR	SCHLAUCH	CAMARA DE AIRE
33D	DALLA CABINA	FROM THE CAB	A PARTIR DE LA CABINE	AB FAHRERHAUS	A PARTIR DE LA CABINA
33E	ELETTROVENTILATORE	ELECTROFAN	VENTILATEUR ELECTRIQUE	ELEKTROLUEFTER	ELECTROVENTILADOR
33I	INDICATORE	INDICATOR	INDICATEUR	ANZEIGER	INDICADOR
33M	MANICOTTO DI TRASCINAMENTO	DRAG SLEEVE	MANCHON	MITNEHMER	MANGUITO
33P	PARETE	WALL	PARI	WAND	PARED
33V	ELETTROVENTILATORE	ELECTROFAN	VENTILATEUR ELECTRIQUE	ELEKTR LUEFTER	ELECTROVENTILADOR
33V					
34C	CAMERA DI TURBOLENZA	SWIRL CHAMBER	CHAMBRE DE TURBULENCE	WIRBELKAMMER	CAMARA DE TURBULENCIA
34C					
34R	REGOLATORE DI PRESSIONE	PRESSURE REGULATOR	REGULATEUR DE PRESSION	DRUCKREGLER	REGULADOR DE PRESSION
34R					

ITEM	PART N.	GRID	ITEM	PART N.	GRID	ITEM	PART N.	GRID	ITEM	PART N.	GRID	ITEM	PART N.	GRID
6	14473280	2-S17	2	14603470	1-T4	1	15645501	3-M15	8	15970731	2-H9	5	15996037	2-L9
24	14483080	1-H10	20	14604770	2-Q17	4	15662001	3-H5	14	15970731	2-I10	7	16038540	3-H16
24	14483081	1-H10	15	14604870	2-P10	3	15663101	3-M10	17	15970921	1-P4	9	16041631	2-N3
36	14489121	2-R9	15	14604870	2-Q17	3	15663101	3-M9	13	15970921	2-H17	9	16043021	3-I8
9	14496201	2-T3	1	14607570	2-N6	18	15840537	2-M2	9	15970921	2-S4	17	16043031	1-I2
3	14496401	1-M2	23	14610970	2-P15	10	15862131	2-N5	7	15970924	2-S3	11	16043031	2-T6
15	14496431	3-H3	2	14625979	3-H12	20	15888721	1-O10	6	15970931	1-P15	14	16043031	2-T8
22	14496501	2-M16	9	14626090	3-H12	16	15888721	1-P4	12	15970931	2-H14	8	16043031	2-T11
4	14496521	1-P6	9	14626290	3-H12	5	15888731	2-M13	16	15970931	2-I6	9	16043031	2-T12
22	14496521	2-R8	4	14626671	3-H12	20	15888831	1-P12	12	15970931	2-I4	3	16043031	2-T15
4	14496521	3-M6	2	14628079	3-H12	19	15888931	3-H17	2	15970931	2-L2	7	16043031	2-T16
16	14496601	2-O17	2	14638179	3-H12	28	15896211	1-L6	23	15970931	3-I16	5	16043031	2-T17
16	14496621	2-O8	20	14641995	3-I16	33	15896211	1-M6	15	15971421	2-O17	24	16043131	1-I8
16	14496621	2-O3	18	14641995	3-I13	4	15896211	1-M2	32	15971521	1-M17	7	16043131	2-I13
11	14496621	2-P3	21	14642095	3-I16	39	15896211	1-N6	17	15971621	1-P2	18	16043131	2-M8
24	14497821	2-T4	18	14642295	3-H17	34	15896211	1-O16	1	15971731	1-P13	26	16043221	1-F10
24	14497821	2-T5	15	14642591	3-L3	5	15896211	3-H7	5	15971831	2-R2	33	16043221	1-M17
1	14522421	3-H12	7	15215031	3-L11	5	15896211	3-H8	21	15971921	1-O9	17	16043221	1-O12
1	14525021	3-H12	10	15540221	2-P6	5	15896211	3-H15	17	15971924	1-P12	17	16043221	1-O11
12	14543170	2-L13	31	15540431	2-L5	22	15896211	3-I16	21	15972121	1-O10	7	16043221	1-P10
20	14549270	2-L6	6	15540431	2-M6	8	15896219	2-S5	25	15972221	1-H10	14	16043231	1-L3
6	14549270	2-L7	11	15540521	2-P6	13	15896221	1-H11	6	15977531	2-N4	9	16043231	1-L5
1	14549579	3-H12	7	15540631	1-O13	2	15896221	3-L8	12	15977931	2-L10	15	16043231	2-I10
1	14549879	3-H12	19	15540721	1-O9	13	15896421	1-L3	20	15977931	2-Q4	15	16043231	2-I8
1	14550079	3-H12	12	15540921	2-P6	2	15903810	3-I2	18	15977931	2-Q2	10	16043231	2-N13
6	14567080	2-I13	13	15540931	2-P6	8	15970331	3-L12	16	15977931	3-L9	11	16043231	3-L17
19	14567080	3-I16	18	15541021	1-O10	21	15970521	1-H5	13	15985631	3-L12	27	16043321	1-H10
17	14567080	3-I13	8	15541131	2-N3	21	15970521	1-H7	13	15985637	2-I4	5	16043321	1-I7
10	14567080	3-I17	5	15541331	1-H3	15	15970531	2-I6	14	15986837	2-I4	6	16043321	1-I6
5	14582790	3-H12	18	15541431	2-L15	6	15970531	2-M13	21	15987931	1-P12	13	16043324	1-I4
1	14585678	3-H14	19	15541521	1-O10	7	15970531	2-T11	9	15988431	2-P8	3	16043331	1-O4
13	14600770	1-I5	9	15541824	2-S3	5	15970531	3-M6	20	15988431	3-H17	6	16043331	1-O3
9	14601270	2-R4	6	15541931	1-H3	16	15970721	1-P2	7	15988637	2-M6	22	16043421	1-H5
11	14601470	2-L10	13	15542331	2-L13	8	15970721	3-I8	13	15989137	2-L10	28	16043421	1-H10
2	14603470	1-Q9	3	15642601	3-H5	25	15970724	1-H7	17	15989331	3-L9	41	16043421	1-I13

ITEM	PART N.	GRID	ITEM	PART N.	GRID	ITEM	PART N.	GRID	ITEM	PART N.	GRID	ITEM	PART N.	GRID
41	16043421	1-I11	6	16043631	2-O7	5	16044131	2-O15	43	16100811	1-I11	28	16160111	1-L9
14	16043421	1-I5	6	16043631	2-O2	6	16044131	2-O,4	26	16100811	1-N9	7	16160131	3-L11
15	16043421	1-O15	6	16043631	2-P4	7	16044131	2-O7	21	16100811	1-O12	7	16321021	1-I15
18	16043421	1-O12	5	16043631	3-H6	7	16044131	2-O2	4	16100811	2-N11	10	16322921	2-P8
18	16043421	1-O11	11	16043631	3-L13	7	16044131	2-P4	9	16100818	2-S5	5	17288681	1-P6
13	16043421	1-O7	15	16043631	3-L14	10	16044131	2-R4	7	16100821	1-H3	3	17669001	3-L2
18	16043421	1-P4	6	16043631	3-M12	16	16044221	1-H11	16	16100821	1-L3	26	19022986	1-O5
15	16043421	1-P7	4	16043631	3-M10	16	16044221	1-H12	12	16100821	1-L8	19	19053182	1-I2
11	16043421	1-P8	3	16043631	3-M8	10	16044224	2-S3	12	16100821	1-M16	15	19053182	1-M14
11	16043421	1-P9	15	16043821	1-H11	20	16044321	1-O12	21	16100821	1-M13	20	19053732	1-L2
22	16043421	1-P12	16	16043821	1-H12	20	16044321	1-O11	4	16100821	1-M12	2	19053382	1-L8
19	16043431	2-M8	16	16043821	1-O14	9	16044431	2-O4	8	16100821	2-O16	17	20063000	2-M10
24	16043431	3-I15	17	16043821	2-M15	42	16044521	1-I13	8	16100821	2-O15	10	20063060	2-P7
19	16043431	3-I13	12	16043824	1-M15	42	16044521	1-I11	7	16100821	2-O14	31	20063440	2-R11
9	16043431	3-L6	15	16043831	1-L3	19	16044521	2-M14	7	16100821	2-O13	17	20063450	2-O8
18	16043431	3-L9	15	16043831	2-O14	9	16044521	2-N11	11	16100821	2-R4	17	20063450	2-O3
12	16043431	3-L17	25	16043831	3-I15	6	16044531	2-O16	25	16100821	2-R8	12	20063450	2-P3
16	16043521	1-H12	29	16043921	1-H10	6	16044531	2-O15	6	16100821	3-H6	19	20063460	2-M2
17	16043531	1-O6	15	16043921	1-H12	17	16044621	1-H11	12	16100821	3-L13	20	20063470	2-M2
4	16043531	1-O4	17	16043921	1-P7	17	16044621	1-H12	7	16100821	3-M6	16	20063470	2-R12
14	16043621	1-H11	18	16043921	2-M15	7	16044631	2-O16	11	16101511	2-S4	1	20147000	2-I2
13	16043621	1-I10	13	16043924	1-M15	7	16044631	2-O15	12	16101511	2-S3	34	20419310	1-M6
14	16043621	1-I9	10	16043931	1-L5	22	16044721	1-O10	8	16101521	1-H3	12	20419310	2-S14
15	16043621	1-O14	20	16043931	2-M8	29	16044731	2-R11	8	16101521	1-O13	1	24941650	2-T4
18	16043621	1-P2	8	16043931	2-O4	22	16044821	1-C9	17	16102311	1-L7	1	24941650	2-T5
16	16043621	1-P7	21	16043931	2-R3	14	16044921	1-H12	17	16102321	1-L3	2	24941660	2-T4
4	16043621	3-M9	27	16044024	1-H8	7	16044921	1-I3	11	16102321	1-L5	2	24941660	2-T5
28	16043624	1-H8	25	16044030	1-N9	23	16044931	2-R8	22	16102321	2-R3	2	26797000	2-I2
13	16043624	1-I4	1	16044031	2-M17	30	16044931	2-R11	4	16102321	3-I11	41	26799910	1-M4
18	16043631	1-I2	6	16044031	2-O14	17	16045021	1-O14	14	16103621	2-L13	16	26800390	2-I10
24	16043631	1-L9	6	16044031	2-O13	24	16045131	2-R8	23	16104111	1-H5	16	26800390	2-I8
19	16043631	1-O12	6	16044031	3-M6	8	16045621	1-I3	23	16104111	1-H7	2	28996480	2-T3
19	16043631	1-O11	10	16044121	2-S4	18	16100811	1-H11	3	16104121	2-M5	19	38824001	1-P2
7	16043631	2-L3	8	16044131	2-N17	18	16100811	1-H12	6	16104411	3-L7	19	40000010	1-H11
11	16043631	2-N5	5	16044131	2-O16	43	16100811	1-I13	7	16105621	2-H13	19	40000011	1-H12

ITEM	PART N.	GRID	ITEM	PART N.	GRID	ITEM	PART N.	GRID	ITEM	PART N.	GRID	ITEM	PART N.	GRID
17	40000150	2-I6	1	70673871	1-R6	4	70910986	1-T10	6	70918850	1-S4	3	70926000	1-R6
17	40000410	2-I10	1	70673871	1-S13	5	70911331	1-Q12	9	70918850	1-S2	2	70926000	1-R8
5	40001070	2-N12	1	70673871	1-T4	5	70911331	1-R4	1	70919134	2-I17	3	70926000	1-S13
17	40001670	2-I8	1	70673871	1-T6	5	70911331	1-R12	1	70919134	2-I16	2	70926000	1-S10
30	40002810	1-H10	1	70673871	2-H4	5	70911331	1-S2	2	70919347	1-Q9	3	70926000	1-T4
30	40003800	1-H10	1	70673871	2-H7	5	70911331	1-T10	4	70921076	1-Q16	2	70926000	1-T6
7	45481995	2-O11	1	70673970	1-P17	6	70912433	1-Q12	4	70921076	1-Q3	3	70926000	2-H4
2	45481995	2-O6	1	70673970	1-Q5	6	70912433	1-R4	4	70921076	1-S16	2	70926000	2-H7
2	45481995	2-P2	1	70673970	1-R16	6	70912433	1-R12	4	70921076	1-S6	7	70926353	2-S8
2	45481995	2-P5	1	70673970	1-S8	6	70912433	1-S2	4	70921076	1-T17	3	70926813	2-R7
8	45482314	3-H16	1	70673970	1-T14	6	70912433	1-T10	10	70921569	1-Q12	2	70927211	1-P17
6	60024509	1-I2	23	70677005	1-I8	3	70914678	1-Q14	7	70921569	1-R2	2	70927211	1-S8
1	70059946	1-Q16	2	70684057	1-L12	7	70914678	1-Q12	10	70921569	1-R4	9	70927536	1-Q14
1	70059946	1-Q3	6	706996	3-H7	3	70914678	1-R2	7	70921569	1-R10	9	70927536	1-R2
1	70059946	1-S16	1	70738582	3-L4	7	70914678	1-R4	10	70921569	1-R12	9	70927536	1-R10
1	70059946	1-S6	4	70738688	3-L4	3	70914678	1-R10	10	70921569	1-S2	9	70927536	1-S4
1	70059946	1-T17	31	70905360	1-Q13	7	70914678	1-R12	7	70921569	1-T8	9	70927536	1-T8
1	70189001	2-S2	31	70905360	1-R3	3	70914678	1-S4	10	70921569	1-T10	11	70927583	1-Q12
2	70189002	2-S2	31	70905360	1-R11	7	70914678	1-S2	5	70922763	1-Q16	11	70927583	1-H4
1	70239517	1-L12	31	70905360	1-T9	3	70914678	1-T8	5	70922763	1-Q3	11	70927583	1-R12
1	70649665	2-S8	2	70910123	1-Q12	7	70914678	1-T10	5	70922763	1-S16	11	70927583	1-S2
1	70659494	2-R7	2	70910123	1-S2	2	70916964	2-S8	5	70922763	1-S6	11	70927583	1-T10
2	70669623	2-R7	2	70910123	1-T10	3	70916965	2-S8	5	70922763	1-T17	10	70927612	1-Q14
2	70673856	1-Q16	3	70910287	1-Q16	4	70917673	1-Q14	4	70923558	2-S8	1	70927612	1-Q10
2	70673856	1-Q3	1	70910287	1-Q14	8	70917673	1-Q12	5	70923560	2-S8	10	70927612	1-R2
2	70673856	1-S16	3	70910287	1-Q12	4	70917673	1-S4	6	70923588	2-S8	1	70927612	1-R5
2	70673856	1-S6	2	70910986	1-Q14	8	70917673	1-S2	2	70924290	2-I17	10	70927612	1-R10
2	70673856	1-T17	4	70910986	1-Q12	8	70917673	1-T10	2	70924290	2-I16	1	70927612	1-R14
1	70673860	1-Q12	2	70910986	1-R2	5	70917970	1-Q14	8	70925821	1-Q14	10	70927612	1-S4
1	70673860	1-R4	4	70910986	1-R4	5	70917970	1-R2	8	70925821	1-R2	1	70927612	1-T3
1	70673860	1-R12	2	70910986	1-R10	5	70917970	1-R10	8	70925821	1-R10	10	70927612	1-T8
1	70673860	1-S2	4	70910986	1-R12	5	70917970	1-S4	8	70925821	1-S4	1	70927612	1-T12
1	70673860	1-T10	2	70910986	1-S4	5	70917970	1-T8	8	70925821	1-T8	3	70927696	1-P17
1	70673871	1-Q9	4	70910986	1-S2	6	70918850	1-Q14	3	70926000	1-Q9	8	70927726	2-S8
1	70673871	1-Q7	2	70910986	1-T8	9	70918850	1-Q12	2	70926000	1-Q7	4	70927747	1-P17

ITEM	PART N.	GRID	ITEM	PART N.	GRID	ITEM	PART N.	GRID	ITEM	PART N.	GRID	ITEM	PART N.	GRID
4	70927747	1-Q5	26	71004797	1-Q5	5	71004961	1-S10	7	71403590	3-L2	24	73116880	2-S8
4	70927747	1-R16	26	71004797	1-R16	5	71004961	1-T6	5	73044040	2-R7	25	73116888	2-S8
4	70927747	1-S8	26	71004797	1-T15	5	71004961	2-H7	6	73045975	2-R7	26	73116890	2-S8
4	70927747	1-T14	2	71004820	1-Q10	6	71004962	1-Q7	7	73045976	2-R7	27	73116893	2-S8
11	70928527	1-Q14	2	71004820	1-R5	6	71004962	1-R8	8	73045977	2-R7	28	73116952	2-S7
11	70928527	1-R2	2	71004820	1-R14	6	71004962	1-S10	4	73046863	1-L12	29	73116955	2-S7
11	70928527	1-R10	2	71004820	1-T3	6	71004962	1-T6	5	73046864	1-L12	7	73116957	1-Q16
11	70928527	1-S4	2	71004820	1-T12	6	71004962	2-H7	8	73052024	3-M6	7	73116957	1-Q3
11	70928527	1-T8	7	71004835	1-P17	8	71005536	1-P17	15	73066768	1-Q12	7	73116957	1-S16
5	70928720	1-P17	7	71004835	1-Q5	8	71005536	1-Q5	15	73066768	1-R4	7	73116957	1-S6
5	70928720	1-Q5	7	71004835	1-R16	8	71005536	1-R16	15	73066768	1-R12	7	73116957	1-T17
5	70928720	1-R16	7	71004835	1-S8	8	71005536	1-S8	15	73066768	1-S2	8	73116959	1-Q16
5	70928720	1-S8	7	71004835	1-T14	8	71005536	1-T14	15	73066768	1-T10	8	73116959	1-Q3
5	70928720	1-T14	14	71004838	1-Q12	9	71008468	1-P17	22	73074679	1-I8	8	73116959	1-S16
4	70929030	2-R7	14	71004838	1-R4	9	71008468	1-Q5	4	73109871	1-Q9	8	73116959	1-S6
5	70929049	2-I11	14	71004838	1-R12	9	71008468	1-R16	7	73109871	1-Q7	8	73116959	1-T17
6	70929166	1-Q16	14	71004838	1-S2	9	71008468	1-S8	4	73109871	1-R6	30	73116961	2-S7
6	70929166	1-Q3	14	71004838	1-T10	9	71008468	1-T14	4	73109871	1-S13	31	73116962	2-S7
6	70929166	1-S16	13	71004848	1-Q14	9	71304372	3-H16	4	73109871	1-T4	32	73116966	2-S7
6	70929166	1-S6	13	71004848	1-R2	10	71304373	3-H16	7	73109871	1-T6	33	73116967	2-S7
6	70929166	1-T17	13	71004848	1-R10	11	71304374	3-H16	4	73109871	2-H4	34	73116968	2-S7
12	70929217	1-Q12	13	71004848	1-S4	12	71304375	3-H16	7	73109871	2-H7	35	73116969	2-S7
9	70930278	2-S8	13	71004848	1-T8	13	71304376	3-H16	11	73116822	2-S8	9	73116971	1-Q16
10	70933816	2-S8	14	71004849	1-Q14	14	71304377	3-H16	12	73116823	2-S8	9	73116971	1-Q3
12	70933875	1-Q14	14	71004849	1-R2	15	71304378	3-H16	13	73116833	2-S8	9	73116971	1-S16
13	70933875	1-Q12	14	71004849	1-R10	16	71304379	3-H16	14	73116834	2-S8	9	73116971	1-S6
6	70933876	1-P17	14	71004849	1-S4	17	71304380	3-H16	15	73116836	2-S8	9	73116971	1-T17
3	70935974	1-P17	14	71004849	1-T8	18	71304381	3-H16	16	73116839	2-S8	36	73116973	2-S7
3	70935974	1-Q5	4	71004926	1-Q7	19	71304385	3-H16	17	73116848	2-S8	37	73116976	2-S7
3	70935974	1-S8	4	71004926	1-R8	20	71304386	3-H16	18	73116849	2-S8	38	73116979	2-S7
3	71004653	1-L12	4	71004926	1-S10	21	71304387	3-H16	19	73116851	2-S8	39	73116981	2-S7
3	71004777	1-Q7	4	71004926	1-T6	22	71304388	3-H16	20	73116859	2-S8	40	73116983	2-S7
27	71004795	1-Q5	4	71004926	2-H7	23	71304389	3-H16	21	73116868	2-S8	41	73116985	2-S7
27	71004795	1-R17	5	71004961	1-Q7	3	71304923	3-H12	22	73116869	2-S8	3	73117031	2-S2
27	71004795	1-T15	5	71004961	1-R8	1	71309808	3-L5	23	73116876	2-S8	4	73117032	2-S2

ITEM	PART N.	GRID	ITEM	PART N.	GRID	ITEM	PART N.	GRID	ITEM	PART N.	GRID	ITEM	PART N.	GRID
5	73117036	2-S2	10	73117963	1-S8	11	73118057	1-S16	12	73118064	1-P17	19	73118073	1-P17
6	73117038	2-S2	10	73117963	1-T14	11	73118057	1-S6	12	73118064	1-Q5	19	73118073	1-Q5
7	73117044	2-S2	17	73118039	1-Q14	11	73118057	1-T17	12	73118064	1-R16	19	73118073	1-R16
8	73117056	2-S2	17	73118039	1-R2	12	73118058	1-Q16	12	73118064	1-S8	19	73118073	1-S8
9	73117058	2-S2	17	73118039	1-R10	8	73118058	1-Q7	12	73118064	1-T14	19	73118073	1-T14
10	73117073	2-S2	17	73118039	1-S4	12	73118058	1-Q3	13	73118065	1-P17	20	73118074	1-P17
3	73117074	2-H7	17	73118039	1-T8	8	73118058	1-R8	13	73118065	1-Q5	20	73118074	1-Q5
11	73117087	2-S2	16	73118040	1-Q12	12	73118058	1-S16	13	73118065	1-R16	20	73118074	1-R16
12	73117088	2-S2	16	73118040	1-R4	8	73118058	1-S10	13	73118065	1-S8	20	73118074	1-S8
13	73117096	2-S2	16	73118040	1-R12	12	73118058	1-S6	13	73118065	1-T14	20	73118074	1-T14
14	73117103	2-S2	16	73118040	1-S2	8	73118058	1-T6	14	73118066	1-P17	21	73118075	1-P17
16	73117119	2-S2	16	73118040	1-T10	12	73118058	1-T17	14	73118066	1-Q5	17	73118080	1-Q16
17	73117126	2-S2	3	73118043	1-Q10	8	73118058	2-H7	14	73118066	1-R16	17	73118080	1-Q3
42	73117147	2-S7	3	73118043	1-R5	13	73118059	1-Q16	14	73118066	1-S8	17	73118080	1-S16
19	73117731	2-S2	3	73118043	1-R14	13	73118059	1-Q3	14	73118066	1-T14	17	73118080	1-S6
21	73117733	2-S2	3	73118043	1-T3	13	73118059	1-S16	15	73118067	1-P17	17	73118080	1-T17
22	73117734	2-S2	3	73118043	1-T12	13	73118059	1-S6	15	73118067	1-Q5	18	73118081	1-Q16
23	73117735	2-S2	4	73118044	1-Q10	13	73118059	1-T17	15	73118067	1-R16	18	73118081	1-Q3
24	73117737	2-S2	4	73118044	1-R5	14	73118060	1-Q16	15	73118067	1-S8	18	73118081	1-S16
25	73117739	2-S2	4	73118044	1-R14	14	73118060	1-S6	15	73118067	1-T14	18	73118081	1-S6
26	73117740	2-S2	4	73118044	1-T3	15	73118061	1-Q16	16	73118068	1-P17	18	73118081	1-T17
27	73117741	2-S2	4	73118044	1-T12	15	73118061	1-Q3	16	73118068	1-Q5	19	73118082	1-Q16
28	73117742	2-S2	18	73118053	1-Q14	15	73118061	1-S16	16	73118068	1-R16	19	73118082	1-Q3
29	73117744	2-S2	18	73118053	1-R2	15	73118061	1-S6	16	73118068	1-S8	19	73118082	1-S16
31	73117746	2-T2	18	73118053	1-R10	15	73118061	1-T17	16	73118068	1-T14	19	73118082	1-S6
32	73117747	2-T2	18	73118053	1-S4	16	73118062	1-Q16	17	73118069	1-P17	19	73118082	1-T17
33	73117748	2-T2	18	73118053	1-T8	16	73118062	1-Q3	17	73118069	1-Q5	20	73118083	1-Q16
34	73117750	2-T2	19	73118054	1-Q14	16	73118062	1-S16	17	73118069	1-R16	20	73118083	1-Q3
36	73117752	2-T2	19	73118054	1-R2	16	73118062	1-S6	17	73118069	1-S8	20	73118083	1-S16
37	73117754	2-T2	19	73118054	1-R10	16	73118062	1-T17	17	73118069	1-T14	20	73118083	1-S6
4	73117875	2-H7	19	73118054	1-S4	11	73118063	1-P17	18	73118072	1-P17	20	73118083	1-T17
4	73117875	2-H6	19	73118054	1-T8	11	73118063	1-Q5	18	73118072	1-Q5	5	73118085	1-Q9
10	73117963	1-P17	10	73118056	1-Q16	11	73118063	1-R16	18	73118072	1-R16	9	73118085	1-Q7
10	73117963	1-Q5	11	73118057	1-Q16	11	73118063	1-S8	18	73118072	1-S8	5	73118085	1-R6
10	73117963	1-R16	11	73118057	1-Q3	11	73118063	1-T14	18	73118072	1-T14	9	73118085	1-R8

ITEM	PART N.	GRID	ITEM	PART N.	GRID	ITEM	PART N.	GRID	ITEM	PART N.	GRID	ITEM	PART N.	GRID
5	73118085	1-S13	12	73118088	2-H7	12	73118092	1-S13	16	73118097	2-H4	21	73118108	2-H7
9	73118085	1-S10	9	73118089	1-Q9	16	73118092	1-S10	17	73118098	1-Q9	22	73118109	1-Q7
5	73118085	1-T4	13	73118089	1-Q7	12	73118092	1-T4	17	73118098	1-R6	22	73118109	1-T6
9	73118085	1-T6	9	73118089	1-R6	16	73118092	1-T6	17	73118098	1-S13	23	73118110	1-Q7
5	73118085	2-H4	13	73118089	1-R8	12	73118092	2-H4	17	73118098	1-T4	23	73118110	1-R8
9	73118085	2-H7	9	73118089	1-S13	16	73118092	2-H7	17	73118098	2-H4	23	73118110	1-S10
6	73118086	1-Q9	13	73118089	1-S10	13	73118093	1-Q9	18	73118106	1-Q9	23	73118110	1-T6
10	73118086	1-Q7	9	73118089	1-T4	17	73118093	1-Q7	19	73118106	1-Q7	23	73118110	2-H7
6	73118086	1-R6	13	73118089	1-T6	13	73118093	1-R6	18	73118106	1-R6	24	73118111	1-Q7
10	73118086	1-R8	9	73118089	2-H4	17	73118093	1-R8	19	73118106	1-R8	24	73118111	1-R8
6	73118086	1-S13	13	73118089	2-H7	13	73118093	1-S13	18	73118106	1-S13	24	73118111	1-S10
10	73118086	1-S10	10	73118090	1-Q9	17	73118093	1-S10	19	73118106	1-S10	24	73118111	1-T6
6	73118086	1-T4	14	73118090	1-Q7	13	73118093	1-T4	18	73118106	1-T4	24	73118111	2-H7
10	73118086	1-T6	10	73118090	1-R6	17	73118093	1-T6	19	73118106	1-T6	5	73118113	2-I17
6	73118086	2-H4	14	73118090	1-R8	13	73118093	2-H4	18	73118106	2-H4	6	73118114	2-I17
10	73118086	2-H7	10	73118090	1-S13	17	73118093	2-H7	19	73118106	2-H7	7	73118115	2-I17
7	73118087	1-Q9	14	73118090	1-S10	14	73118094	1-Q9	19	73118107	1-Q9	7	73118115	2-I16
11	73118087	1-Q7	10	73118090	1-T4	18	73118094	1-Q7	20	73118107	1-Q7	8	73118116	2-I17
7	73118087	1-R6	14	73118090	1-T6	14	73118094	1-R6	19	73118107	1-R6	8	73118116	2-I16
11	73118087	1-R8	10	73118090	2-H4	18	73118094	1-R8	20	73118107	1-R8	9	73118117	2-I17
7	73118087	1-S13	14	73118090	2-H7	14	73118094	1-S13	19	73118107	1-S13	9	73118117	2-I16
11	73118087	1-S10	11	73118091	1-Q9	18	73118094	1-S10	20	73118107	1-S10	10	73118118	2-I17
7	73118087	1-T4	15	73118091	1-Q7	14	73118094	1-T4	19	73118107	1-T4	10	73118118	2-I16
11	73118087	1-T6	11	73118091	1-R6	18	73118094	1-T6	20	73118107	1-T6	11	73118119	2-I17
7	73118087	2-H4	15	73118091	1-R8	14	73118094	2-H4	19	73118107	2-H4	11	73118119	2-I16
11	73118087	2-H7	11	73118091	1-S13	18	73118094	2-H7	20	73118107	2-H7	22	73118121	1-Q14
8	73118088	1-Q9	15	73118091	1-S10	15	73118096	1-Q9	20	73118108	1-Q9	22	73118121	1-R2
12	73118088	1-Q7	11	73118091	1-T4	15	73118096	1-R6	21	73118108	1-Q7	22	73118121	1-R10
8	73118088	1-R6	15	73118091	1-T6	15	73118096	1-S13	20	73118108	1-R6	22	73118121	1-S4
12	73118088	1-R8	11	73118091	2-H4	15	73118096	1-T4	21	73118108	1-R8	22	73118121	1-T8
8	73118088	1-S13	15	73118091	2-H7	15	73118096	2-H4	20	73118108	1-S13	23	73118122	1-Q14
12	73118088	1-S10	12	73118092	1-Q9	16	73118097	1-Q9	21	73118108	1-S10	23	73118122	1-R2
8	73118088	1-T4	16	73118092	1-Q7	16	73118097	1-R6	20	73118108	1-T4	23	73118122	1-R10
12	73118088	1-T6	12	73118092	1-R6	16	73118097	1-S13	21	73118108	1-T6	23	73118122	1-S4
8	73118088	2-H4	16	73118092	1-R8	16	73118097	1-T4	20	73118108	2-H4	23	73118122	1-T8

ITEM	PART N.	GRID	ITEM	PART N.	GRID	ITEM	PART N.	GRID	ITEM	PART N.	GRID	ITEM	PART N.	GRID
2	73118123	1-Q14	28	73118136	1-S10	29	73118171	1-R11	22	73118369	1-Q9	5	74052780	1-Q10
24	73118123	1-S4	21	73118136	1-T4	29	73118171	1-S4	22	73118369	1-T4	31	74055100	1-Q13
25	73118124	1-Q14	28	73118136	1-T7	29	73118171	1-T9	12	73119134	2-S4	13	76000174	1-L8
25	73118124	1-R2	21	73118136	2-H4	22	73118173	1-Q17	38	73119570	2-T2	14	76000175	1-L8
25	73118124	1-R10	28	73118136	2-H8	22	73118173	1-Q5	39	73119636	2-T2	15	76000208	1-L8
25	73118124	1-S4	29	73118137	1-Q6	22	73118173	1-R16	40	73119637	2-T2	18	76000589	2-I6
25	73118124	1-T8	29	73118137	1-R8	22	73118173	1-S8	43	73119703	2-S7	19	76000591	2-I6
1	73118125	2-I15	29	73118137	1-S10	22	73118173	1-T14	8	73124564	2-S9	18	76000804	2-Q15
2	73118126	2-I15	29	73118137	1-T7	23	73118174	1-Q17	44	73125149	2-S7	11	76000804	2-Q12
3	73118127	2-I15	29	73118137	2-H8	23	73118174	1-Q5	45	73130213	2-S7	21	76000809	2-Q4
4	73118128	2-I15	30	73118138	1-Q6	23	73118174	1-R16	4	73131677	1-R2	22	76000811	2-Q4
1	73118128	2-I14	30	73118138	1-R9	23	73118174	1-S8	8	73131677	1-R4	12	76000905	2-T6
5	73118129	2-I15	30	73118138	1-S9	23	73118174	1-T14	4	73131677	1-R10	8	76000905	2-T16
6	73118130	2-I15	30	73118138	1-T7	24	73118175	1-Q17	8	73131677	1-R12	3	76000905	3-H2
7	73118131	2-I15	30	73118138	2-H8	24	73118175	1-Q5	4	73131677	1-T8	8	76001392	2-Q3
25	73118133	1-Q7	31	73118139	1-Q6	24	73118175	1-R16	41	73131960	2-T2	9	76001393	2-Q3
25	73118133	1-R8	31	73118139	1-R9	24	73118175	1-S8	6	73131968	3-H8	10	76001394	2-Q3
25	73118133	1-S10	31	73118139	1-S9	24	73118175	1-T14	21	73132674	1-P17	18	76001632	1-L7
25	73118133	1-T6	31	73118139	1-T7	32	73118236	1-Q6	21	73132674	1-Q5	20	76001854	2-Q14
25	73118133	2-H7	31	73118139	2-H8	32	73118236	1-R9	21	73132674	1-R16	13	76001854	2-Q12
26	73118134	1-Q7	26	73118166	1-Q14	32	73118236	1-S9	21	73132674	1-S8	21	76001856	2-Q14
26	73118134	1-R8	26	73118166	1-R2	32	73118236	1-T7	21	73132674	1-T14	14	76001856	2-Q12
26	73118134	1-S10	26	73118166	1-S4	32	73118236	2-H8	3	73132784	1-Q7	32	76001883	2-L5
26	73118134	1-T6	27	73118167	1-Q13	21	73118262	1-Q16	3	73132784	1-R8	33	76001884	2-L5
26	73118134	2-H7	27	73118167	1-R2	21	73118262	1-Q3	3	73132784	1-S10	34	76001885	2-L5
27	73118135	1-Q6	27	73118167	1-R10	21	73118262	1-S16	3	73132784	1-T6	35	76001887	2-L5
27	73118135	1-R8	27	73118167	1-S4	21	73118262	1-S6	3	73132784	2-H7	7	76002365	1-P15
27	73118135	1-S10	27	73118167	1-T8	21	73118262	1-T17	10	73132932	1-Q16	5	76002402	3-M9
27	73118135	1-T6	28	73118170	1-Q13	22	73118320	1-Q16	10	73132932	1-Q3	2	76002604	2-I11
27	73118135	2-H7	28	73118170	1-R2	22	73118320	1-Q3	10	73132932	1-S16	23	76004175	2-R3
21	73118136	1-Q9	28	73118170	1-R10	22	73118320	1-S16	10	73132932	1-S6	9	76004839	2-L6
28	73118136	1-Q6	28	73118170	1-S4	22	73118320	1-S6	10	73132932	1-T17	2	76004839	2-L7
21	73118136	1-R6	28	73118170	1-T8	22	73118320	1-T17	20	73133823	2-S2	2	76004958	2-N6
28	73118136	1-R8	29	73118171	1-Q13	8	73118329	2-I15	5	73153575	3-L8	21	76005096	1-L2
21	73118136	1-S13	29	73118171	1-R3	2	73118329	2-I14	30	74052780	1-Q13	1	76006064	2-I13

ITEM	PART N.	GRID	ITEM	PART N.	GRID	ITEM	PART N.	GRID	ITEM	PART N.	GRID	ITEM	PART N.	GRID
5	76006881	3-I11	11	76010230	2-O4	19	76014545	1-L2	9	76015987	2-N7	9	79001971	2-O16
13	76007483	2-H9	8	76010327	2-P4	9	76014842	3-L12	8	76016148	3-L3	9	79001971	2-O15
9	76008340	3-M6	5	76010328	2-P7	31	76014857	3-I5	11	76016149	3-L3	8	79001971	2-O14
10	76008341	3-M6	5	76010329	2-P7	30	76014887	3-I5	7	76016181	3-H3	8	79001971	2-O13
11	76008344	3-M6	23	76010357	1-L5	20	76014890	1-L2	7	76016182	3-H3	19	79002004	2-L15
8	76008353	2-N6	26	76010396	2-T7	1	76014937	1-P3	4	76016276	2-R17	21	79002121	2-M2
8	76008353	2-N7	20	76010396	2-T14	11	76014938	1-P7	22	76016328	2-H14	14	79002642	2-L14
1	76008353	2-N9	12	76010540	1-L5	29	76014976	3-I5	17	76016701	2-O16	1	79002868	3-M16
9	76008354	2-N6	7	76010546	1-O4	17	76015039	3-I5	17	76016701	2-O15	19	79002971	2-M10
10	76008354	2-N7	9	76010549	1-O3	14	76015040	2-N7	14	76016702	2-O4	8	79003030	2-T16
2	76008354	2-N9	10	76010554	1-O3	7	76015040	2-N8	9	76016703	2-P4	3	79003030	3-H2
12	76008360	3-M6	20	76010585	2-T10	14	76015041	2-N7	12	76016704	2-O5	32	79003603	2-R11
3	76008643	2-O17	5	76011135	2-M7	7	76015041	2-N8	1	76016782	2-L3	8	79003622	2-L3
13	76008671	2-O13	7	76011184	3-L7	9	76015201	2-N7	13	76016784	2-L3	21	79003679	2-M8
7	76009588	3-H8	8	76011194	3-L7	30	76015371	2-L17	3	76017076	3-L8	22	79003686	2-M8
5	76009946	2-P5	2	76012109	3-I9	18	76015371	2-M17	4	76017079	3-L8	23	79004433	2-M8
15	76010175	2-O15	1	76012112	3-I9	27	76015372	2-N15	24	76017245	2-Q16	9	79004903	2-L3
15	76010176	2-O15	23	76012151	1-H14	20	76015587	1-P2	22	76017329	2-Q7	4	79004919	2-H11
10	76010177	2-O17	17	76012442	1-I9	21	76015591	1-P2	23	76017693	2-Q7	15	79005177	2-L11
14	76010182	2-O15	9	76012946	3-L7	20	76015592	1-P4	24	76017700	2-Q16	16	79005188	2-L13
19	76010183	2-O15	23	76013041	1-P12	6	76015614	1-L10	14	76017737	2-L3	8	79005238	3-M14
13	76010184	2-O17	13	76013747	2-Q5	7	76015615	1-L10	15	76017739	2-L3	5	79005238	3-M13
20	76010185	2-O17	6	76013894	2-T17	23	76015616	1-L9	5	76017930	2-S5	14	79005239	3-L12
14	76010186	2-O17	6	76013894	3-H3	21	76015617	1-L8	2	76018081	1-P13	9	79005242	1-H3
4	76010187	2-O17	7	76013904	3-H3	20	76015624	2-N16	7	76018199	2-L7	22	79005242	1-L2
11	76010188	2-O17	7	76013905	3-H3	21	76015654	1-L2	5	76018203	2-L7	20	79005244	2-I6
9	76010189	2-O17	9	76014155	2-P4	25	76015664	1-L2	10	76018207	2-L7	13	79005244	3-L17
0	76010197	2-O13	13	76014156	2-S14	22	76015682	2-R5	12	76018214	2-L7	8	79005584	2-H12
12	76010202	2-O13	14	76014157	2-S14	3	76015769	3-L8	22	76019025	2-T10	9	79005596	2-H12
13	76010215	2-P3	15	76014158	2-S14	4	76015770	3-L8	18	76019434	2-L13	8	79005596	2-H13
14	76010216	2-P3	16	76014159	2-S14	13	76015787	2-N7	17	76019435	2-L13	13	79005596	2-H14
15	76010217	2-P3	4	76014252	2-T15	13	76015788	2-N7	5	76019926	3-L8	10	79005597	2-H12
16	76010218	2-P3	5	76014253	2-T15	9	76015984	2-P4	15	79001971	2-N16	33	79005597	2-H15
17	76010219	2-P3	7	76014422	2-T17	13	76015985	2-S14	9	79001971	2-N17	11	79005598	2-H12
12	76010228	2-O4	20	76014544	1-L2	14	76015986	2-S14	21	79001971	2-O17	12	79005599	2-H12

ITEM	PART N.	GRID	ITEM	PART N.	GRID	ITEM	PART N.	GRID	ITEM	PART N.	GRID	ITEM	PART N.	GRID
9	79005599	2-H13	21	79010772	2-L15	11	79012327	2-L11	4	79012999	2-I2	24	79013599	3-H16
14	79005599	2-H14	13	79010932	2-N5	12	79012328	2-L11	13	79013164	2-L6	7	79013600	3-H15
10	79005601	2-H13	6	79011386	1-L12	22	79012341	2-L15	8	79013164	2-L7	8	79013601	3-H15
15	79005601	2-H14	7	79011387	1-L12	23	79012344	2-L16	22	79013289	2-I10	17	79013628	2-H14
16	79005602	2-H14	9	79011405	2-T11	24	79012349	2-L16	20	79013289	2-I8	18	79013631	2-H14
13	79005607	2-H12	36	79011575	2-L5	10	79012399	2-L3	23	79013293	2-I10	11	79013633	2-H13
14	79005610	2-H12	37	79011576	2-L5	3	79012409	2-N6	11	79013302	1-H13	19	79013637	2-H14
21	79005781	3-H17	14	79011643	2-T6	4	79012410	2-N6	9	79013310	2-H9	20	79013638	2-H14
11	79005934	3-L6	4	79011643	2-T14	6	79012413	2-N6	10	79013319	2-H9	6	79013659	2-N12
10	79005965	2-L6	15	79011645	2-T6	6	79012414	2-N6	11	79013324	2-H9	21	79013702	2-H14
11	79005965	2-L7	15	79011645	2-T14	7	79012415	2-N6	25	79013328	2-I6	10	79013994	1-H3
15	79006212	2-R5	4	79011645	3-L2	8	79012420	2-N6	24	79013334	2-I10	11	79013999	1-H3
15	79006339	2-H12	16	79011647	2-T6	1	79012420	2-N9	21	79013334	2-I8	12	79014002	1-H3
16	79006358	2-R5	16	79011647	2-T14	9	79012421	2-N6	32	79013338	2-I9	11	79014002	2-P8
13	79006370	2-T6	17	79011649	2-T6	2	79012421	2-N9	25	79013339	2-I10	13	79014006	1-H3
13	79006370	2-T14	17	79011649	2-T14	38	79012426	2-L5	22	79013339	2-I8	10	79014057	3-M17
23	79007135	1-L2	34	79011775	2-R11	11	79012435	2-L6	26	79013340	2-I9	1	79014117	3-I16
16	79007569	1-L8	5	79012035	3-H5	13	79012435	2-L7	27	79013342	2-I9	7	79014134	2-N12
17	79007570	1-L8	6	79012036	3-H5	6	79012583	3-M9	7	79013343	2-L12	8	79014136	2-N12
21	79007711	2-I6	20	79012205	2-R5	7	79012600	3-H7	8	79013344	2-L12	9	79014143	2-N12
19	79007717	2-M10	21	79012207	2-R5	8	79012600	3-H8	13	79013345	2-L11	10	79014182	2-N12
26	79008554	3-I15	18	79012293	2-I10	24	79012662	2-M2	7	79013412	3-H5	9	79014262	3-M14
22	79009016	3-H17	18	79012293	2-I8	24	79012663	2-M2	8	79013413	3-H5	10	79014263	3-M14
8	79009581	2-M2	22	79012295	2-I6	11	79012675	2-N3	9	79013414	3-H5	9	79014524	1-O13
8	79009582	2-M2	19	79012300	2-I10	26	79012676	2-M2	15	79013422	1-I9	10	79014536	1-O13
12	79009877	2-N5	19	79012300	2-I8	27	79012677	2-N2	3	79013422	2-L2	5	79014617	2-M7
11	79010160	3-L11	19	79012301	2-I10	28	79012678	2-N2	24	79013422	2-M16	11	79014634	2-N13
24	79010217	1-L2	19	79012301	2-I8	29	79012681	2-N2	10	79013422	2-T11	15	79014681	1-P16
12	79010350	3-L8	19	79012302	2-I10	30	79012682	2-N2	10	79013422	2-T12	12	79014712	2-N13
17	79010369	2-R5	19	79012302	2-I8	12	79012869	2-L6	5	79013422	3-H2	5	79014718	2-H11
18	79010375	2-R6	23	79012304	2-I6	15	79012989	2-I4	8	79013422	3-H3	6	79014722	2-H11
19	79010377	2-R5	24	79012305	2-I6	16	79012991	2-I4	8	79013422	3-H7	22	79015263	2-R5
16	79010401	3-L14	5	79012318	2-L12	17	79012992	2-I4	9	79013422	3-H8	11	79015317	3-M14
33	79010455	2-R11	6	79012319	2-L12	6	79012996	2-M3	7	79013538	2-M13	11	79015319	3-M14
20	79010771	2-L15	10	79012325	2-L11	3	79012997	2-I2	6	79013586	3-H15	18	79015411	1-L8

ITEM	PART N.	GRID	ITEM	PART N.	GRID	ITEM	PART N.	GRID	ITEM	PART N.	GRID	ITEM	PART N.	GRID
10	79015450	2-M17	23	79019060	2-R6	28	79020868	2-I9	11	79022017	2-O14	20	79022809	2-P3
19	79015697	1-L8	24	79019062	2-R6	7	79020934	3-L2	11	79022017	2-O13	26	79022824	2-R8
11	79015882	2-M17	25	79019065	2-R6	16	79020938	3-I5	20	79022096	1-O6	27	79022826	2-R9
12	79016206	2-M17	12	79019318	2-N3	8	79020952	3-I6	13	79022153	2-H9	28	79022827	2-R9
20	79016255	2-N14	7	79019318	2-N4	7	79020961	3-H11	26	79022154	2-H10	35	79022904	2-R11
21	79016256	2-N14	13	79019406	2-N3	26	79021009	3-H17	14	79022167	2-H9	5	79023080	3-M10
9	79016327	3-L12	14	79019407	2-N3	16	79021065	2-N3	18	79022226	1-P7	7	79023080	3-M9
25	79016503	2-L16	9	79019490	2-S9	10	79021203	2-N17	12	79022240	3-M14	18	79023131	2-N3
26	79016511	2-L16	31	79019557	2-N2	16	79021558	2-O8	19	79022242	1-P4	12	79023131	2-N4
19	79016720	3-L9	15	79019707	2-M17	18	79021558	2-O3	24	79022250	2-R3	7	79023159	2-S17
23	79016843	3-H17	14	79019721	2-L10	18	79021558	2-P3	25	79022251	2-R3	8	79023160	2-S17
24	79016845	3-H17	15	79019722	2-L10	10	79021573	3-I8	26	79022254	2-R3	9	79023161	2-S17
3	79017076	2-I11	16	79019723	2-L10	17	79021584	2-N3	16	79022272	3-M14	10	79023162	2-S17
4	79017077	2-I11	17	79019730	2-L10	10	79021616	2-O14	17	79022273	3-M14	8	79023510	2-O11
25	79017091	3-H17	18	79019731	2-L10	3	79021616	2-O13	13	79022276	3-M14	9	79023515	2-O11
7	79017116	1-O8	17	79019853	2-L13	11	79021617	2-N17	6	79022276	3-M13	10	79023516	2-O11
11	79017173	2-T12	18	79019855	2-L13	19	79021643	2-O8	14	79022277	3-M14	11	79023529	2-O11
10	79017173	3-L12	18	79020239	3-M6	19	79021643	2-O3	7	79022277	3-M13	12	79023531	2-R15
7	79017647	3-M12	8	79020334	1-P15	19	79021643	2-P3	17	79022291	2-R12	13	79023535	2-R15
22	79017713	2-N15	9	79020337	1-P15	20	79021644	2-O8	4	79022468	2-T4	14	79023536	2-R15
23	79017723	2-N15	10	79020354	2-S9	20	79021644	2-O3	4	79022468	2-T5	1	79023782	3-M11
10	79017741	3-I3	14	79020511	1-I10	15	79021810	2-N5	12	79022484	2-T4	1	79023783	3-M11
11	79017742	3-I3	4	79020511	3-H2	16	79021814	2-N5	12	79022484	2-T5	1	79023784	3-M11
3	79017755	3-I6	9	79020511	3-H3	17	79021815	2-N5	14	79022535	1-H3	1	79023785	3-M11
4	79017756	3-I6	16	79020577	2-M17	18	79021817	2-N5	15	79022536	1-H3	1	79023786	3-M11
9	79017861	2-M17	8	79020682	2-N4	19	79021818	2-N5	16	79022537	1-H3	1	79023787	3-M11
13	79017862	2-M17	9	79020689	2-N4	20	79021819	2-N5	22	79022760	2-H14	10	79023843	2-N6
14	79017863	2-M17	10	79020690	2-N4	10	79021898	2-O16	23	79022764	2-H14	4	79023900	2-M5
16	79017912	1-O6	15	79020691	2-N3	10	79021898	2-O15	24	79022768	2-H14	19	79023955	2-N3
19	79017913	1-O6	11	79020691	2-N4	11	79021899	2-O16	2	79022774	3-H9	27	79023984	3-H17
13	79018210	2-O14	14	79020694	2-N5	11	79021899	2-O15	16	79022777	2-H12	28	79023986	3-I17
9	79018215	2-O14	5	79020832	3-I6	12	79021902	2-O16	8	79022803	2-I13	26	79023988	2-I6
12	79018505	2-H13	6	79020842	3-I6	12	79021902	2-O15	9	79022804	2-I13	27	79023989	2-I5
13	79018675	3-M6	7	79020844	3-I6	16	79021915	2-P11	21	79022809	2-O8	18	79023991	2-I4
12	79018945	2-H9	17	79020859	2-M17	24	79021915	2-P15	21	79022809	2-O8	8	79023993	2-M13

ITEM	PART N.	GRID	ITEM	PART N.	GRID	ITEM	PART N.	GRID	ITEM	PART N.	GRID	ITEM	PART N.	GRID
7	79023998	2-O10	16	79025274	3-L6	11	79026134	2-L3	21	79026974	3-L9	13	79027337	3-L11
7	79023998	2-O9	17	79025276	3-L6	22	79026148	3-L14	15	79026977	2-L14	24	79027338	3-L9
13	79024045	2-N13	21	79025283	2-N5	23	79026149	3-L14	7	79027031	2-M7	25	79027342	2-N15
5	79024229	2-M5	25	79025284	2-P15	24	79026153	3-L14	8	79027034	2-M7	20	79027347	3-I13
6	79024330	2-M5	11	79025284	2-S17	25	79026154	3-L14	9	79027038	2-M7	20	79027348	3-I13
7	79024331	2-M5	39	79025347	2-L5	9	79026197	1-L11	14	79027055	3-L16	14	79027364	3-L13
15	79024337	3-M14	25	79025361	2-H14	12	79026197	1-O13	15	79027056	3-L16	18	79027392	3-L17
15	79024338	3-M14	9	79025399	3-L16	9	79026217	3-I6	26	79027057	3-L15	15	79027405	3-L13
6	79024350	3-M10	17	79025453	3-L14	8	79026297	3-M10	27	79027058	3-L15	8	79027408	3-M17
8	79024418	3-M12	18	79025458	3-L14	9	79026298	3-M10	18	79027068	2-L14	8	79027410	3-M17
8	79024442	2-M6	10	79025462	3-L16	29	79026346	2-I9	19	79027070	2-L14	19	79027424	3-L17
9	79024444	2-M6	11	79025468	3-L16	16	79026395	2-N16	36	79027076	2-R11	28	79027428	3-L15
10	79024445	2-M6	12	79025469	3-L16	17	79026397	2-N16	37	79027077	2-R11	14	79027502	2-N13
8	79024446	3-M13	19	79025470	3-L14	18	79026399	2-N16	38	79027078	2-R11	15	79027503	2-N13
28	79024479	2-Q11	13	79025470	3-L16	24	79026400	2-N15	39	79027079	2-R11	16	79027504	2-N13
11	79024575	2-N12	16	79025494	2-T4	19	79026402	2-N16	41	79027080	2-R11	17	79027505	2-N13
7	79024644	3-M10	16	79025494	2-T5	6	79026476	2-I2	14	79027107	2-L6	18	79027506	2-N13
15	79024729	2-H9	20	79025508	3-L14	1	79026566	3-M7	21	79027108	2-N13	19	79027507	2-N13
7	79024738	2-H11	14	79025535	3-L17	31	79026646	2-H15	12	79027110	2-L3	16	79027559	3-L13
10	79024798	1-P15	15	79025536	3-L17	14	79026649	2-H13	13	79027126	2-L3	26	79027589	2-N15
20	79024802	3-I17	16	79025540	3-L17	30	79026650	2-H15	11	79027131	2-S9	15	79027688	2-N12
7	79024821	2-M3	17	79025541	3-L17	6	79026708	2-M7	15	79027136	2-L6	16	79027925	2-H13
5	79024824	2-I2	21	79025548	3-L14	18	79026740	2-O9	16	79027140	2-L6	17	79027926	2-H13
16	79025182	2-H9	13	79025574	3-L13	18	79026740	2-O7	17	79027146	2-L6	18	79027927	2-H13
18	79025222	2-O8	11	79025801	2-N6	19	79026742	2-O9	18	79027147	2-L6	26	79027929	2-H14
13	79025223	2-Q10	12	79025802	2-N6	19	79026742	2-O7	19	79027160	2-L6	27	79027931	2-H14
17	79025223	2-O9	13	79025810	2-N6	14	79026831	2-N6	14	79027197	2-L3	28	79027933	2-H15
19	79025223	2-O8	11	79025853	1-O13	15	79026832	2-N6	15	79027198	2-L3	20	79027942	1-L8
17	79025223	2-O7	9	79025861	2-T16	6	79026832	2-N7	16	79027224	2-P10	30	79027981	3-I17
7	79025239	3-M17	11	79025920	3-L12	3	79026834	2-N9	16	79027224	2-Q17	30	79027982	3-I17
7	79025241	3-M17	2	79025961	3-H2	6	79026835	2-N7	40	79027268	2-R11	30	79027983	3-I17
13	79025247	3-L6	2	79025962	3-H2	4	79026835	2-N9	22	79027289	3-L9	20	79028055	1-P2
14	79025250	3-L6	9	79026104	2-M13	5	79026836	2-N9	22	79027296	3-L9	21	79028056	1-P2
20	79025271	2-N3	10	79026105	2-M13	12	79026918	3-L11	29	79027304	2-L16	20	79028057	1-P5
15	79025273	3-L6	19	79026121	1-L7	20	79026936	3-L9	5	79027335	2-O12	22	79028058	1-P2

ITEM	PART N.	GRID	ITEM	PART N.	GRID	ITEM	PART N.	GRID	ITEM	PART N.	GRID	ITEM	PART N.	GRID
7	79028069	1-O3	7	79028613	3-H10	5	79029322	2-P12	20	79030124	2-I4	21	79030217	1-Q12
17	79028146	2-H9	7	79028814	3-H10	14	79029327	2-P8	13	79030132	1-O13	21	79030217	1-R4
12	79028166	2-N17	7	79028815	3-H10	6	79029332	2-P12	20	79030150	3-L17	21	79030217	1-R12
18	79028166	2-O15	11	79028816	3-H10	15	79029335	2-P8	9	79030200	3-H11	21	79030217	1-S2
11	79028189	1-F15	12	79028817	3-H10	7	79029335	2-P12	3	79030200	3-H13	21	79030217	1-T10
8	79028190	2-H11	12	79028818	3-H10	8	79029380	2-P12	23	79030209	1-Q9	33	79030218	1-O6
9	79028193	2-H11	12	79028819	3-H10	9	79029412	2-P12	23	79030209	1-R6	33	79030218	1-T7
3	79028197	2-O6	15	79028820	3-H10	6	79029436	2-R2	23	79030209	1-S13	33	79030218	2-H8
3	79028197	2-P2	16	79028821	3-H10	7	79029646	2-O5	23	79030209	1-T4	34	79030219	1-Q6
3	79028197	2-P5	16	79028822	3-H10	8	79029657	2-O5	23	79030209	2-H4	34	79030219	1-T7
4	79028198	2-O6	18	79028823	3-H10	10	79029790	2-O10	24	79030210	1-Q9	34	79030219	2-H8
4	79028198	2-P2	10	79028824	3-H10	8	79029813	2-M3	24	79030210	1-R6	22	79030220	1-Q12
4	79028198	2-P5	19	79028825	3-H10	10	79029841	2-O9	24	79030210	1-S13	22	79030220	1-S2
20	79028256	2-N13	19	79028826	3-H10	11	79029844	2-O10	24	79030210	1-T4	22	79030220	1-T10
12	79028262	2-R4	19	79028827	3-H10	11	79029844	2-O9	24	79030210	2-H4	23	79030221	1-Q11
17	79028263	2-R4	19	79028828	3-H10	9	79029864	3-M12	17	79030211	1-Q12	23	79030221	1-S2
29	79028272	3-L15	19	79028829	3-H10	10	79029865	3-M12	17	79030211	1-R4	23	79030221	1-T10
28	79028288	2-L16	19	79028830	3-H10	3	79029872	2-L8	17	79030211	1-R12	35	79030222	1-Q6
3	79028289	3-H9	19	79028831	3-H10	4	79029877	2-L8	17	79030211	1-S2	35	79030222	1-T7
26	79028299	2-R6	1	79028904	2-I12	5	79029878	2-L8	17	79030211	1-T10	35	79030222	2-H8
30	79028347	3-L15	6	79028977	3-H12	6	79029879	2-L8	18	79030212	1-Q12	36	79030223	1-Q6
17	79028382	2-H10	6	79028978	3-H12	7	79029880	2-L8	18	79030212	1-R4	36	79030223	1-T7
30	79028394	2-I9	8	79028979	3-H11	17	79029881	1-H3	18	79030212	1-S2	36	79030223	2-H8
5	79028402	2-I11	6	79028979	3-H12	17	79029882	1-H3	18	79030212	1-T10	24	79030224	1-Q11
8	79028455	2-O10	6	79028981	3-H12	5	79029963	2-O6	25	79030214	1-Q8	24	79030224	1-S2
8	79028455	2-O9	7	79028981	3-H12	5	79029963	2-P2	19	79030215	1-Q12	26	79030225	1-Q8
9	79028462	2-O10	18	79028983	2-H10	5	79029963	2-P5	19	79030215	1-R4	26	79030225	1-R6
9	79028462	2-O9	21	79029122	2-N3	11	79029964	2-R17	19	79030215	1-R12	26	79030225	1-S13
1	79028806	3-H10	13	79029122	2-N4	12	79029965	2-R17	19	79030215	1-S2	26	79030225	1-T4
2	79028807	3-H10	22	79029123	2-N3	7	79030013	2-R2	19	79030215	1-T10	26	79030225	2-H4
3	79028808	3-H10	14	79029123	2-N4	8	79030014	2-R2	20	79030216	1-Q12	27	79030226	1-Q8
4	79028809	3-H10	15	79029124	2-N4	24	79030099	1-H5	20	79030216	1-R4	27	79030226	1-R6
5	79028810	3-H10	16	79029125	2-N4	24	79030099	1-H7	20	79030216	1-R12	27	79030226	1-S13
6	79028811	3-H10	12	79029304	2-P8	19	79030120	2-I4	20	79030216	1-S2	27	79030226	1-T4
7	79028812	3-H10	13	79029322	2-P8	20	79030122	2-I4	20	79030216	1-T10	27	79030226	2-H4

ITEM	PART N.	GRID	ITEM	PART N.	GRID	ITEM	PART N.	GRID	ITEM	PART N.	GRID	ITEM	PART N.	GRID
28	79030227	1-Q8	42	79030236	1-T7	25	79030247	1-Q3	26	79030256	1-Q17	8	79030269	1-R14
28	79030227	1-T5	42	79030236	2-H8	25	79030247	1-S16	26	79030256	1-S8	8	79030269	1-T3
37	79030228	1-Q6	42	79030237	1-Q6	25	79030247	1-S6	27	79030257	1-Q17	8	79030269	1-T12
37	79030228	1-R9	42	79030237	1-R9	25	79030247	1-T17	27	79030257	1-S8	9	79030270	1-Q10
37	79030228	1-S9	42	79030237	1-S9	26	79030248	1-Q15	32	79030261	1-Q15	9	79030270	1-R5
37	79030228	1-T7	42	79030237	1-T7	26	79030248	1-S15	32	79030261	1-Q2	9	79030270	1-R14
37	79030228	2-H8	42	79030237	2-H8	26	79030248	1-S5	32	79030261	1-S15	9	79030270	1-T3
38	79030229	1-Q6	42	79030238	1-Q6	26	79030248	2-H2	32	79030261	1-S5	9	79030270	1-T12
38	79030229	1-T7	42	79030238	1-R9	27	79030249	1-Q15	32	79030261	2-H2	10	79030271	1-Q10
29	79030230	1-Q8	42	79030238	1-S9	27	79030249	1-Q2	32	79030262	1-Q13	10	79030271	1-R5
29	79030230	1-R7	42	79030238	1-T7	27	79030249	1-S15	32	79030262	1-S3	10	79030271	1-R14
29	79030230	1-S12	42	79030238	2-H8	27	79030249	1-S5	33	79030263	1-Q13	10	79030271	1-T3
29	79030230	1-T5	42	79030239	1-Q6	27	79030249	2-H2	33	79030263	1-R3	10	79030271	1-T12
29	79030230	2-H5	42	79030239	1-R9	28	79030250	1-Q15	33	79030263	1-R11	11	79030277	1-Q10
30	79030231	1-Q8	42	79030239	1-S9	28	79030250	1-Q2	33	79030263	1-S3	11	79030277	1-R5
30	79030231	1-T5	42	79030239	1-T7	28	79030250	1-S15	33	79030263	1-T9	11	79030277	1-R14
31	79030232	1-Q8	42	79030239	2-H8	28	79030250	1-S5	34	79030264	1-Q13	11	79030277	1-T3
31	79030232	1-R7	42	79030240	1-Q6	28	79030250	2-H2	34	79030264	1-S3	11	79030277	1-T12
31	79030232	1-S12	42	79030240	1-R9	29	79030251	1-Q15	6	79030265	1-Q10	15	79030400	2-T8
31	79030232	1-T5	42	79030240	1-S9	29	79030251	1-Q2	6	79030265	1-T3	13	79030421	2-Q16
31	79030232	2-H5	42	79030240	1-T7	29	79030251	1-S15	26	79030266	1-Q11	13	79030421	2-Q15
39	79030233	1-Q6	42	79030240	2-H8	29	79030251	1-S5	26	79030266	1-R4	1	79030434	3-H13
39	79030233	1-R9	25	79030241	1-Q11	29	79030251	2-H2	26	79030266	1-R12	9	79030474	2-R7
39	79030233	1-T7	25	79030241	1-R4	30	79030252	1-Q15	26	79030266	1-S2	10	79030475	2-R7
39	79030233	2-H8	25	79030241	1-R12	30	79030252	1-Q2	26	79030266	1-T11	11	79030476	2-R7
40	79030234	1-Q6	25	79030241	1-S2	30	79030252	1-S15	27	79030267	1-Q11	12	79030477	2-R7
40	79030234	1-R9	25	79030241	1-T11	30	79030252	1-S5	27	79030267	1-S2	13	79030478	2-R7
40	79030234	1-S9	23	79030242	1-Q16	30	79030252	2-H2	27	79030267	1-T11	14	79030479	2-R7
40	79030234	1-T7	23	79030242	1-Q3	31	79030253	1-Q15	7	79030268	1-Q10	22	79030538	2-M8
40	79030234	2-H8	23	79030242	1-S16	31	79030253	1-Q2	7	79030268	1-R5	12	79030539	2-M8
41	79030235	1-Q6	23	79030242	1-S6	31	79030253	1-S15	7	79030268	1-R14	10	79030649	3-M15
41	79030235	1-T7	23	79030242	1-T17	31	79030253	1-S5	7	79030268	1-T3	10	79030650	3-M15
42	79030236	1-Q6	24	79030246	1-Q15	31	79030253	2-H2	7	79030268	1-T12	2	79030670	3-M16
42	79030236	1-R9	24	79030246	1-S6	25	79030255	1-Q17	8	79030269	1-Q10	12	79030703	2-Q11
42	79030236	1-S9	25	79030247	1-Q15	25	79030255	1-S8	8	79030269	1-R5	13	79030705	2-Q11

ITEM	PART N.	GRID	ITEM	PART N.	GRID	ITEM	PART N.	GRID	ITEM	PART N.	GRID	ITEM	PART N.	GRID
14	79030706	2-O11	4	79031047	2-P7	27	79032011	2-N15	14	79033806	2-Q10	36	79034756	3-I17
16	79030901	2-P8	11	79031048	2-P7	25	79032036	1-L2	20	79033808	2-Q9	27	79034988	1-L3
16	79030902	2-L14	9	79031049	2-P7	27	79032087	2-R6	20	79033808	2-Q7	28	79034989	1-L4
17	79030913	2-L14	7	79031050	2-P7	14	79032209	1-O13	22	79033895	3-L17	21	79035017	1-O6
35	79030999	1-Q13	8	79031051	2-P7	31	79032222	3-I17	23	79033899	3-L17	8	79035023	1-Q3
35	79030999	1-R3	15	79031114	2-O11	8	79032224	3-L2	18	79033907	3-L6	5	79035026	1-O4
35	79030999	1-R11	28	79031238	1-Q17	6	79032225	3-L2	24	79033959	3-L17	29	79035034	1-L4
35	79030999	1-S3	28	79031238	1-S7	5	79032226	3-L2	25	79034003	3-L17	20	79035034	1-L5
35	79030999	1-T9	29	79031239	1-Q17	13	79032280	2-T12	16	79034091	3-L16	19	79035102	2-P16
36	79031000	1-Q13	29	79031239	1-S7	18	79032396	2-T6	20	79034241	1-L3	20	79035106	2-P16
36	79031000	1-R3	32	79031240	1-Q6	10	79032396	2-T16	14	79034241	1-L5	16	79035109	2-O14
36	79031000	1-R11	32	79031240	1-R7	1	79032396	3-H2	21	79034242	1-L3	9	79035111	2-S10
36	79031000	1-S3	32	79031240	1-S12	19	79032398	2-T6	15	79034242	1-L5	17	79035168	5-L16
36	79031000	1-T9	32	79031240	1-T5	19	79032398	2-T14	22	79034246	1-L3	23	79035170	1-P12
28	79031001	1-Q11	32	79031240	2-H5	15	79032513	2-R7	16	79034246	1-L5	24	79035173	1-P12
28	79031001	1-R4	18	79031279	1-L3	15	79032514	2-R7	23	79034254	1-L3	3	79035175	1-P13
28	79031001	1-R12	12	79031355	2-T12	4	79032699	2-L2	24	79034255	1-L3	26	79035257	3-L17
28	79031001	1-T2	13	79031633	2-R4	16	79033172	2-T9	17	79034255	1-L5	10	79035269	2-O4
28	79031001	1-T11	7	79031654	2-I2	12	79033412	3-L12	25	79034256	1-L3	11	79035301	3-M12
29	79031002	1-Q11	8	79031655	2-I2	25	79033501	3-L9	13	79034256	1-L5	27	79035414	3-L17
29	79031002	1-R4	21	79031722	2-N13	26	79033502	3-L10	26	79034258	1-L3	17	79035418	2-T9
29	79031002	1-R12	7	79031741	3-H6	3	79033531	2-M5	19	79034258	1-L5	10	79035451	2-M7
29	79031002	1-T2	12	79031744	3-L13	23	79033531	2-N3	32	79034260	2-N2	3	79035485	1-M2
29	79031002	1-T11	12	79031813	3-I3	9	79033532	2-M5	34	79034264	1-R3	11	79035515	2-O4
37	79031003	1-Q13	13	79031814	3-I3	26	79033535	2-N3	28	79034265	3-I15	32	79035549	3-I17
37	79031003	1-R3	14	79031815	3-I3	26	79033536	2-N3	28	79034268	3-I15	33	79035550	3-I17
37	79031003	1-R11	15	79031816	3-I3	28	79033537	2-N3	33	79034278	3-I15	9	79035555	2-P9
37	79031003	1-S3	10	79031831	3-I6	19	79033634	2-H13	33	79034279	3-I15	19	79035712	3-L6
37	79031003	1-T9	17	79031844	2-P10	10	79033648	2-M5	29	79034284	3-I15	13	79035754	2-N17
47	79031008	1-Q6	17	79031844	2-Q17	10	79033651	2-M5	16	79034377	2-O11	22	79035754	2-O8
47	79031008	1-T7	13	79031845	2-R17	14	79033661	2-R4	19	79034391	2-M16	22	79035754	2-O3
3	79031035	2-P7	27	79032003	3-I15	15	79033672	2-R4	29	79034477	2-R9	9	79035757	2-O5
3	79031036	2-P7	20	79032009	2-N16	16	79033674	2-R4	30	79034518	3-I15	14	79035757	2-P6
6	79031040	2-P7	30	79032010	2-L17	29	79033719	2-N3	27	79034524	3-L11	8	79035758	2-O7
4	79031046	2-P7	18	79032010	2-M17	17	79033719	2-N4	28	79034526	3-I10	8	79035758	2-O2

ITEM	PART N.	GRID	ITEM	PART N.	GRID	ITEM	PART N.	GRID	ITEM	PART N.	GRID	ITEM	PART N.	GRID
6	79035759	2-O6	21	79036682	1-L8	17	79037560	2-S13	15	79038367	2-S17	16	79039610	2-N6
6	79035759	2-P2	4	79036696	3-M8	35	79037578	3-I17	12	79038368	2-S17	18	79039719	2-N4
19	79035760	2-H10	20	79036707	1-L7	21	79037580	3-I13	19	79038729	2-R13	19	79039721	2-N4
28	79035762	2-N15	21	79036733	2-H10	21	79037583	3-I13	15	79038734	2-T12	15	79039806	2-O16
20	79035763	2-H10	12	79036837	2-N12	21	79037585	3-I13	16	79038735	2-T13	15	79039807	2-O16
9	79035764	2-O7	13	79036838	2-N12	22	79037586	3-I13	7	79039312	3-M16	2	79039814	2-P7
9	79035764	2-O2	2	79036898	3-M7	21	79037588	3-I13	8	79039313	3-M16	2	79039815	2-P7
2	79035786	3-M15	7	79036901	2-M10	5	79037635	3-M16	9	79039314	3-M16	12	79039816	2-O4
3	79035787	3-M15	21	79036906	1-L7	6	79037636	3-M16	10	79039315	3-M16	10	79039818	2-O7
4	79035788	3-M15	30	79036912	1-L4	7	79037639	3-M15	11	79039317	3-M16	10	79039818	2-O2
3	79035791	3-M16	31	79036913	1-L4	8	79037640	3-M15	17	79039427	2-O16	10	79039820	2-O5
4	79035792	3-M16	21	79036913	1-L5	9	79037641	3-M15	18	79039429	2-R13	11	79039822	2-O5
5	79035794	3-M15	32	79036915	1-L4	22	79037665	1-O12	14	79039467	2-O4	18	79039833	2-T9
6	79035795	3-M15	19	79036919	1-L3	23	79037668	1-O12	10	79039469	2-S15	33	79040203	2-N2
10	79035908	2-S5	13	79036919	1-L5	6	79037695	1-O4	11	79039473	2-S15	34	79040204	2-N2
14	79035945	3-L11	31	79036971	3-L15	9	79037699	1-O3	11	79039486	2-O7	35	79040208	2-N2
9	79035975	3-M17	26	79037005	1-L2	10	79037706	1-O3	11	79039486	2-O2	13	79040211	2-O4
8	79035976	3-M9	34	79037033	3-I17	22	79037738	1-O6	12	79039487	2-R16	29	79040490	2-I5
17	79036068	2-P11	2	79037282	2-L3	23	79037740	1-O6	18	79039487	2-S13	30	79040491	2-I5
5	79036507	2-L2	6	79037282	2-L13	24	79037742	1-O6	13	79039492	2-R16	15	79040505	3-L11
6	79036548	2-L2	1	79037282	3-L14	25	79037744	1-O5	19	79039492	2-S13	41	79040769	2-R11
7	79036549	2-L2	20	79037299	2-T6	7	79037745	1-O4	40	79039521	3-I17	30	79040776	2-R9
8	79036550	2-L2	20	79037299	2-T14	5	79037810	3-H9	37	79039522	3-I17	31	79040777	2-R9
9	79036564	2-L2	14	79037301	2-T12	3	79037996	3-M7	36	79039523	3-I17	32	79040784	2-R9
10	79036588	2-L2	21	79037303	2-T6	22	79038143	2-H10	39	79039524	3-I17	13	79040912	3-L3
11	79036591	2-L2	22	79037304	2-T6	23	79038145	2-H10	23	79039526	3-I12	36	79040915	2-N2
12	79036592	2-L2	21	79037380	1-H4	14	79038227	2-R16	31	79039527	3-I15	2	79041020	3-L5
11	79036601	2-M13	25	79037380	1-H5	12	79038227	2-S15	32	79039528	3-I15	3	79041021	3-L5
17	79036604	2-R13	31	79037400	1-H17	11	79038228	2-R16	31	79039529	3-I15	4	79041135	3-L5
10	79036604	2-R16	31	79037439	1-H10	9	79038228	2-S15	32	79039530	3-I15	7	79041160	2-O3
17	79036604	2-S14	20	79037439	1-H11	13	79038242	1-N10	33	79039532	3-I15	5	79041164	3-L5
12	79036640	2-O14	9	79037439	1-I3	10	79038242	1-N17	33	79039533	3-I15	1	79041288	2-P14
14	79036641	2-O16	31	79037501	1-H17	3	79038248	1-N17	12	79039545	2-O5	21	79041699	2-N13
22	79036679	1-L9	31	79037536	2-I9	2	79038338	3-L4	13	79039548	2-S17	43	79041702	2-R11
23	79036681	1-L9	31	79037536	2-I7	9	79038360	3-H7	14	79039551	2-S17	44	79041703	2-R11

ITEM	PART N.	GRID	ITEM	PART N.	GRID	ITEM	PART N.	GRID	ITEM	PART N.	GRID	ITEM	PART N.	GRID
42	79041704	2-R11	22	79043345	3-I5	8	79044952	2-M13	17	79047903	2-O16	23	79050442	1-O11
23	79041764	2-O8	10	79043349	3-I10	29	79044954	2-L17	17	79047903	2-O15	21	79050458	1-I8
23	79041764	2-O3	19	79043350	3-I8	18	79044956	2-L14	14	79047904	2-O4	18	79050459	1-I9
18	79041953	1-H3	25	79043354	3-I5	19	79044958	2-L14	11	79047905	2-O7	19	79050460	1-I9
7	79042186	3-I11	26	79043367	3-I12	33	79045083	3-I7	11	79047905	2-O2	26	79050503	2-I5
6	79042406	3-I11	8	79043369	1-O8	10	79045350	3-H7	9	79047905	2-P4	9	79050648	2-O6
10	79042598	1-L11	20	79043371	2-T10	10	79045350	3-H8	12	79047906	2-O5	9	79050648	2-P2
11	79042599	1-L11	23	79043436	2-M16	15	79045487	3-H2	19	79048203	3-L9	9	79050648	2-P5
12	79042600	1-L11	10	79043442	2-M17	23	79045509	3-I8	15	79048237	2-Q10	14	79051055	3-L3
13	79042602	1-L11	24	79043444	2-H10	9	79045510	3-I11	21	79048237	2-Q9	26	79051076	1-R10
10	79042629	2-P12	14	79043491	2-H12	10	79045519	3-H3	21	79048237	2-Q7	26	79051076	1-T8
4	79042633	3-H9	24	79043580	3-I3	43	79045694	2-R11	15	79048245	3-L12	6	79051077	1-R2
23	79042811	2-T6	13	79043703	2-O14	44	79045695	2-R11	25	79048258	3-L10	9	79051077	1-R4
23	79042811	2-T14	1	79043802	2-M2	10	79045845	2-O13	26	79048258	3-L10	6	79051077	1-R10
24	79042812	2-T6	31	79043805	2-N2	10	79045846	3-H7	18	79048266	2-P10	9	79051077	1-R12
24	79042812	2-T14	5	79043879	1-I2	29	79045870	3-L10	18	79048266	2-Q17	6	79051077	1-T3
25	79042813	2-T6	25	79044358	3-I3	29	79045873	3-L10	12	79048326	2-T12	9	79051077	1-T10
25	79042813	2-T14	24	79044382	3-I5	33	79045951	2-R9	19	79048346	2-P10	22	79051090	1-R6
26	79042823	2-T7	10	79044383	3-I2	34	79045952	2-R9	19	79048346	2-Q17	22	79051090	1-S13
12	79043315	3-M16	11	79044384	3-I2	22	79046186	1-P5	16	79048629	1-I9	22	79051090	2-H4
5	79043102	3-I11	13	79044386	3-I6	12	79046186	1-P8	18	79048771	2-T9	26	79051101	1-Q3
8	79043193	1-L10	14	79044387	3-I6	15	79046237	3-M6	22	79049511	2-H10	15	79051192	2-H11
9	79043201	1-L10	8	79044438	3-M8	16	79046238	3-M6	4	79049513	2-H11	2	79051194	3-H9
11	79043237	3-I13	6	79044457	3-M8	17	79046240	3-M6	21	79050169	3-I13	9	79051198	1-O8
27	79043274	2-T7	7	79044458	3-M8	12	79046604	3-L3	21	79050170	3-I13	3	79051200	3-H9
27	79043274	2-T14	5	79044469	3-M8	14	79047121	1-M2	28	79050171	3-I12	2	79051207	1-Q5
16	79043296	3-I3	27	79044554	3-I5	8	79047124	1-I10	17	79050293	3-I8	2	79051207	1-R16
11	79043299	3-I6	28	79044555	3-I5	34	79047158	3-I15	18	79050321	2-T10	2	79051207	1-T14
19	79043300	3-I3	27	79044613	3-I12	35	79047165	3-I15	10	79050329	3-L2	25	79051688	1-Q5
16	79043301	3-I5	27	79044614	3-I12	13	79047637	2-L2	3	79050331	3-L4	25	79051688	1-R16
20	79043302	3-I3	14	79044789	3-M6	14	79047724	2-R16	17	79050355	1-I9	25	79051688	1-T14
21	79043304	3-I3	26	79044942	2-I5	12	79047724	2-S15	22	79050381	1-O12	16	79051730	3-I3
22	79043307	3-I3	11	79044947	2-M13	20	79047724	2-S13	22	79050381	1-O11	16	79051731	3-I3
12	79043312	3-I6	22	79044948	2-L16	19	79047725	2-R13	20	79050429	1-I9	17	79051794	3-L3
23	79043316	3-I3	23	79044950	2-L16	15	79047726	2-S17	23	79050442	1-O12	9	79051795	3-L3

ITEM	PART N.	GRID	ITEM	PART N.	GRID	ITEM	PART N.	GRID	ITEM	PART N.	GRID	ITEM	PART N.	GRID
10	79051796	3-L3	22	79052456	3-I8	33	79055159	1-Q2	30	79055160	1-T2	7	79058653	2-M3
7	79051797	3-L3	29	79052459	3-I7	38	79055159	1-R3	12	79055160	1-T3	4	79058654	2-I2
5	79051798	3-L3	34	79052460	3-I7	38	79055159	1-R11	33	79055160	1-T5	14	79059927	1-Q16
6	79051799	3-L3	25	79052461	3-I7	30	79055159	1-R17	48	79055160	1-T7	14	79059927	1-Q3
4	79051800	3-L3	24	79052464	3-I8	33	79055159	1-S15	39	79055160	1-T9	14	79059927	1-S16
1	79051801	3-L3	12	79052465	3-I10	30	79055159	1-S7	30	79055160	1-T11	14	79059927	1-S6
2	79051802	3-L3	9	79052468	3-L2	33	79055159	1-S5	12	79055160	1-T12	14	79059927	1-T17
3	79051803	3-L3	24	79052635	1-Q3	38	79055159	1-S3	31	79055160	1-T15	3	79060003	2-I14
11	79051804	3-L3	24	79052635	1-S16	38	79055159	1-T9	34	79055160	2-H2	24	79060004	1-T10
3	79051805	3-I2	24	79052635	1-T17	30	79055159	1-T15	33	79055160	2-H5	28	79060005	1-R7
4	79051806	3-I2	22	79052636	1-R8	33	79055159	2-H2	48	79055160	2-H8	28	79060005	1-S12
18	79051807	3-L3	22	79052636	1-S10	31	79055160	1-Q17	12	79055160	2-I17	28	79060005	2-H5
20	79051813	3-I8	22	79052636	2-H7	34	79055160	1-Q15	12	79055160	2-I16	38	79060006	1-R9
11	79051814	3-I8	41	79052638	1-R9	39	79055160	1-Q13	25	79055596	1-L9	38	79060006	1-S9
21	79051818	3-I8	10	79053317	1-O8	30	79055160	1-Q11	18	79055596	1-O14	38	79060006	2-H8
16	79051819	3-I8	14	79053320	2-H11	12	79055160	1-Q10	15	79055596	1-O13	41	79060008	1-S9
8	79051832	3-I2	12	79053321	2-H11	33	79055160	1-Q8	23	79055596	1-P2	41	79060008	2-H8
9	79051833	3-I2	26	79053325	3-I5	48	79055160	1-Q6	21	79055596	1-P5	31	79060009	1-R4
7	79051834	3-I2	17	79053326	3-I5	31	79055160	1-Q4	29	79056360	1-Q4	31	79060009	1-R13
5	79051835	3-I2	18	79053327	3-I5	34	79055160	1-Q2	29	79056360	1-R17	31	79060009	1-T11
14	79051837	3-I8	31	79053328	3-I7	39	79055160	1-R3	29	79056360	1-T15	24	79060010	1-R2
14	79051838	3-I8	18	79053329	3-I8	30	79055160	1-R4	34	79056361	1-R11	24	79060010	1-R10
12	79051840	3-I8	28	79053330	3-I7	12	79055160	1-R5	34	79056361	1-T9	24	79060010	1-T8
13	79051841	3-I8	11	79053347	1-Q8	33	79055160	1-R7	6	79056362	1-R5	28	79060011	1-Q4
30	79051842	3-I7	27	79053435	1-R4	48	79055160	1-R9	6	79056362	1-R14	28	79060011	1-R17
16	79051843	3-L3	27	79053435	1-R12	39	79055160	1-R11	6	79056362	1-T12	28	79060011	1-T15
6	79051844	3-I2	5	79054137	3-H9	30	79055160	1-R13	1	79056873	3-H6	32	79060012	1-R3
8	79051846	3-L3	4	79054141	3-H9	12	79055160	1-R14	12	79057500	2-S9	32	79060012	1-R11
12	79051870	3-I3	6	79054632	3-I11	31	79055160	1-R17	14	79057502	2-S9	32	79060012	1-T9
16	79052017	2-M17	7	79054634	3-I11	34	79055160	1-S15	11	79057724	1-P15	3	79060013	2-I16
31	79052025	2-L17	8	79054635	3-I11	33	79055160	1-S12	15	79058644	2-T8	5	79060014	2-I16
27	79052161	1-L9	30	79055159	1-Q17	48	79055160	1-S9	23	79058647	2-I8	6	79060015	2-I16
32	79052166	3-I7	33	79055159	1-Q15	31	79055160	1-S7	32	79058649	2-I7	4	79060016	2-I14
20	79052451	1-I9	38	79055159	1-Q13	34	79055160	1-S5	29	79058650	2-I7	5	79060017	2-I14
21	79052452	1-I8	30	79055159	1-Q4	39	79055160	1-S3	30	79058651	2-I7	9	79060061	3-M8

DESIGNAZIONE BASE	BASIC DESIGNATION	DESIGNATIONS-BASES	GRUNDBEZEICHNUNGEN	DENOMINACIONES BASE	
50G	GHIERA	RING NUT	FRETTE	NUTMUTTER	VITOLA
50I	INGRANAGGIO	GEAR	PIGNON	ZAHNRAD	PISTON
50N	NOTTOLINO	PAWL	CLIQUET	KLINKE	SEGURO
50P	PAVIMENTO	FLOOR	PLANCHER	BODEN	PISO
50S	SCHIENALE	SEAT BACK	DOSSIER	RUECKENLEHNE	RESPALDO
50T	TAPPO	PLUG	BOUCHON	STOPFEN	TAPON
50V	VOLANTE	STEERING WHEEL	VOLANT DE DIRECTION	LENKRAD	VOLANTE DE DIRECCION
505	CATENARIA LUBRIFICATA	SALT TRACK CHAIN	CHEVILLE LUBRIFIEE	KETTENZUG OELGESCHMIERT	
51A	ANELLO DI SICUREZZA	LOCKRING	ARRETOIR	SICHERUNGSRING	ANILLO DE FRENO
51B	BIELLA MOTORE	CONNECTING ROD	BIELLE	PLEUEL	BIELA PISTON
51G	GHIERA FILETTATA	THREADED RING	ECROU	GEWINDERING	TUERCA
51M	MARTELLLO	HAMMER	MARTEAU	HAMMER	MARTILLO
516	SUOLE (3 COSTOLE)	SHOES (3 GROUSERS)	PATINS (3 COTES)	KETTENPLATTE (3-STEG)	
517	SUOLE (2 COSTOLE)	SHOES (2 GROUSERS)	PATINS (2 COTES)	KETTENPLATTE (2-STEG)	
52A	ANELLO SPINGIDISCO	PRESSURE PLATE	PLATEAU DE PRES- SION	DRUCKPLATTE	PLATO DE EMPUJE
52A					
52F	FIANCHETTO	SIDE PANEL	TABLIER	SEITENBLECH	CHAPA
52V	VOLTMETRO	VOLTMETER	VOLTMETRE	VOLTMETER	VOLTIMETRO
53A	ANELLO STANTUFFO	PISTON RING	SEGMENT	KOLBENRING	ARO DE EMBOLO
53C	CANNA CILINDRO	TUBE	CHEMISE	ZYLINDERBUECHSE	CAMISA DE CILINDRO
53D	DIODO	DIODE	DIODE	DIODE	DIODO
53F	FINO AL TELAIO	UP TO SERIAL NO	JUSQU'AU CHASSIS	BIS FAHRGESTELL	HASTA EL CHASSIS
53T	TAPPO DI INTRODUZIONE OLIO CON	DIPSTICK W/CAP	BOUCHON AVEC JAUGE	SCHRAUBDECKEL	TAPON CON VARILLA
53T	ASTA LIVELLO		D'HUILE	MIT MESSTAB	DE NIVEL DE ACEITE
53V	VERSOIO	PUSH PLATE	LAME VERSOIR	PFLUGSCHAR	REJA
530	SUOLE (1 COSTOLA)	SHOES (1 GROUSER)	PATIN (1 COTE)	KETTENPLATTE (1-STEG)	
531	SUOLE AUTOPULENTI	SELF CLEANING SHOES	PATINS AUTONETTOYANTS	KETTENPLATTE (SELBSTREINIGEND)	
534	SUOLE H D	SHOES H D	PATINS RENFORCES	KETTENPLATTE (H D)	
54A	ANELLI STANTUFFO	PISTON RINGS	SEGMENTS	KOLBENRINGE	AROS DE EMBOLO
54C	CANDELA MAGNETICA	MAGNETIC ROD	TIGE MAGNETIQUE	MAGNETEINSATZ	VARILLA IMANADA
54I	INSERTO FILETTATO	INSERT	INSERT	GEWINDEEINSATZ	ROSCA POSIZA
54R	RIDUTTORE DI ROTAZIONE	SWING REDUCTION UNIT	REDUCTEUR DE VI- TESSE DE ROTATION	UNTERSATZUNGSGE- TRIEBE	REDUCTOR DE VELO- CIDAD DE ROTACION
54R					
54T	TAPPO INTRODUZIONE	FILLER CAP	BOUCHON DE REMPLISSAGE	EINFUELLSTUTZEN	TAPON DE LLENADO
549	MEZZA SERIE SOPRASUOLE	STREET PLATES-HALF SERIES	DEMI-JEU PATINS DE ROUTE	STRASSENSCHUHE-HALBREIHUNG	
55A	ANELLO TENUTA	JUNK RING	JOINT D ETANCHEITE	DICHTRING	JUNTA HERMETICA
55B	BILANCIERE	ROCKER	CULBUTEUR	KIPPEBEL	BALANCIN
55E	ESTINTORE	FIRE EXTINGUISHER	EXTINCTEUR	FEUERLOESCHER	EXTINTOR
55F	FIBBIA	BUCKLE	BOUCLE	SCHNALLE	HEBILLA
55L	LIMA	FILE	LIME	FEILE	LIMA

DESIGNAZIONE BASE	BASIC DESIGNATION	DESIGNATIONS-BASES	GRUNDBEZEICHNUNGEN	DENOMINACIONES BASE	
55M	MARTINELLO	JACK	CRIC	WAGENHEBER	GATO
55R	RIBATTINO	RIVET	RIVET	NIET	REMAC-IE
55T	TAPPO DI RIDUZIONE	ADAPTER	BOUCHON DE REDUC- TION	REDUZIERSTOPFEN	TAPON DE REDUCCION
55T					
56A	ANELLO DI RITEGNO	RETAINING RING	ARRETOIR	HALTERING	RETENEDOR
56C	CANDELA PRERISCALDO	GLOW PLUG	BOUGIE PRECHAUFFAGE	GLUEHKERZE	BUJIA DE CALENTAMIENTO
56L	LIMITATORE	TRAVEL LIMITER	LIMITEUR	ANSCHLAG	TOPE
56T	TAPPO DI SCARICO	DRAIN PLUG	BOUCHON DE VIDANGE	ABLASS-STOPFEN	TAPON DE DESCARGA
56I	RIPARI GUIDA CATENA	TRACK CHAIN GUIDING GUARD	PROTECTION SU/DE CHENILLE	KETTENFUEHRUNG	
563	RIPARI RUOTE CARRELLO	TRACK ROLLER GUARD	PROTECTIONS ROUES CHARIOT	LAUFROLLENSCHUTZ	
565	GUIDE PER ARCONO	C-FRAME GUIDES	GUIDES POUR ETRIER	SCHUBRAHMEN FUEHRUNG	
57C	CANTONALE	GUSSET	MOUCHOIR	ECKSTUECK	ANGULAR
57D	DISAERATORE	DEAERATOR	DESAERATEUR	ENTLUEFTER	DESAIREADOR
57R	RIDUTTORE DI PRESSIONE	PRESSURE REDUCER	REDUCTEUR DE PRES- SION	DRUCKMINDERER	REDUCTOR DE PRE- SION
57R					
57T	TAPPO MAGNETICO	MAGNETIC PLUG	BOUCHON MAGNETIQUE	MAGNETSTOPFEN	TAPON IMANADO
572	ELETTORISCALDATORE		RECHAUFFEUR ELECTRIQUE	ELEKTROHEIZUNG	
58A	ANELLO A DOPPIO CONO	BALL SLEEVE	BI-CONE	DICHTKEGEL	ANILLO BICONICO
58C	CALAMITA	MAGNET	AIMANT	MAGNET	IMAN
58R	RIDUTTORE	REDUCTION GEAR	REDUCTEUR	UNTERSETZUNGSGETRIEBE	REDUCTOR
58D	TETTuccio PARASOLE	SUN CANOPY			
58I	CABINA SICUREZZA (C.CONDIZION)	ROPS CAB (W.CONDITION-R)	CABINE DE SECURITE(CONDITION)	SICHERHEITSKABINE MIT KLIMAANL	
582	CABINA SICUREZZA-SPECIAL	ROPS CAB-SPECIAL	CABINE DE SECURITE-SPECIAL	SICHERHEITSKABINE SONDERAUSFUEH	
59A	ANELLO TRASCINAMENTO	DRIVING RING	CRABOTAGE	MITNEHMER	ANILLO DE ARRASTRE
59D	DISCO PORTAFRENO	BRAKE BACK PLATE	DISQUE PORTE-FREIN	BREMSTRAEGER	DISCO PORTAFRENO
59R	RIDUTTORE CAMBIO	TRANSMISSION REDUCTION GEAR	REDUCTEUR DE B V	UNTERSETZUNGSGETRIE	REDUCTOR DEL CAMBIO
60A	ANGOLARE	ANGLE	CORNIERE	WINKELISEN	ANGULAR
60B	BISCOTTINO	SHACKLE	JUMELLE	LASCHE	PALANCA
60C	CAPOCORDA	WIRE TERMINAL	COSSE	KABELSCHUH	TERMINAL
60D	DISCO	DISC	DISQUE	SCHEIBE	DISCO
60E	ESTRATTORE	PULLER	EXTRACTEUR	ABZIEHER	EXTRACTOR
60F	FILO	WIRE	FIL	DRAHT	HILD
60G	GIRANTE	IMPELLEN	ROTOR	PUMPENRAD	IMPULSOR
60I	INGRASSATORE	GREASE FITTING	GRAISSEUR	SCHMIERNIPPEL	ENGRASADOR
60L	LINGUETTA	KEY	CLAVETTE	KEIL	CHAVETA
60N	NUCLEO	CORE	NOYAU	ANKER	NUCLEO
60P	PEDALE	PEDAL	PEDALE	PEDAL	PEDAL
60R	RINFORZO	REINFORCEMENT	RENFORT	VERSTAERKUNG	REFUERZO
60S	SCODELLINO	CUP	CUVETTE	TELLERSCHEIBE	CASQUILLO
60T	TASSELLO	BLOCK	TAMPON	BLOCK	TACO

DESIGNAZIONE BASE	BASIC DESIGNATION	DESIGNATIONS-BASES	GRUNDSZEICHNUNGEN	DENOMINACIONES BASE
604	CONDIZIONAMENTO CABINA	AIR CONDITIONING		
607	VISIERA PARASOLE	SUN VISOR		
61C	CONTRAPPESO	COUNTERWEIGHT	CONTREPOIDS	CONTRAPESO
61E	ESTREMITÀ	END	EXTREMITÉ	EXTREMO
61F	FILO ACCIAIO	STEEL WIRE	FIL D'ACIER	ALAMBRE DE ACERO
61L	LINGUETTA A DISCO	WOODRUF KEY	CLAVETTE A DISQUE	CHAVETA A DISCO
61T	TASSELLO ELASTICO	CUSHION PAD	TAMPON ELASTIQUE	ALMOHADILLA
612	SPECCHIO RETROVISORE INTERNO	INSIDE REAR VIEW MIRROR	RETROVISEURS INTERIEUR	ESPEJOS RETROVISORES INTERIOR
613	SPECCHIO RETROVISORE ESTERNO	OUTSIDE REAR VIEW MIRROR	RETROVISEUR EXTERIEUR	ESPEJOS RETROVISORES EXTERIOR
614	VETRI P/OMOLOGAZIONE EUROPEA			
619	LAMPADA ROTANTE	ROTATING BEACON	LAMPE CLIGNOTANTE A ROTATION	
62C	CAPOTE	FOLDING TOP	CAPOTE	CAPOTA
62E	ESTREMITÀ DEL TIRANTE	TIEROD HEAD	EXTREMITÉ DU TIRANT	EXTREMO DEL PERNO
62L				
62T	CONTRAPPESO	COUNTERWEIGHT	MASSELOTTE	CONTRAPESO
63A	ANTICIPO AUTOMATICO	AUTOMATIC ADVANCE	AVANCE AUTOMATIQUE	AVANCE AUTOMATICO
63A				
63C	CAPPELLETTO VALVOLA RUOTA	WHEEL VALVE CAP	CHAPEAU	CAPUCHON
63F	FILTRO A BARRETTA	ROD FILTER	FILTRE A BARRETTE	FILTRO DE BARRETA
63R	RINVIO	BELL CRANCK	RENOI A LEVIER	RENVIO DE PALANCA
630	EMERGENZA STERZATURA	EMERGENCY STEERING	SYSTEME DE DIRECTION SECOURS	SISTEMA DIRECCION EMERGENCIA
633	FRENATURA DIFFERENZIATA	INDEPENDENT BRAKING DEVICE		
634	IMPIANTO FRENO TUV-ITALIA	BRAKE SYSTEM, TUV-ITALY		
64C	CAPPELLO	CAP	CHAPEAU	SOMBRERO
64D	DISCO FRENO	BRAKE DISC	DISQUE DE FREIN	DISCO DE FRENO
64E	EVAPORATORE	EVAPORATOR	EVAPORATEUR	EVAPORADOR
64F	FILTRO COMBUSTIBILE	FUEL FILTER	FILTRE COMBUSTIBLE	FILTRO COMBUSTIBLE
64I	INNESTO ELETTROMAGNETICO	ELECTROMAGNETIC COUPLING	ENCLICHEMENT	ACOPLO ELECTROMAGNETICO
64I				
64P	PEDANA	FLOOR PLATE	PLANCHER	ESTRIBO
64R	RINVIO ANGOLARE	MITER GEARING	RENOI D'ANGLE	RENVIO ANGULAR
65A	ANTICONGELANTE	ANTIFREEZE	ANTIGIVREUR	DESCONGELADOR
65C	CAPPUCGIO	BOOT	CAPUCHON	CAPUCHON
65D	DISCO FRIZIONE	CLUTCH DISC	DISQUE D'EMBRAYAGE	DISCO DE EMBRAGUE
65F	FILTRO	FILTER	FILTRE	FILTRO
65G	GIUNTO CARDANICO	UNIVERSAL JOINT	JOINT DE CARDAN	JUNTA UNIVERSAL
65I	INNESTO	DRIVE	ENCLICHEMENT	ACOPLAMIENTO
65L	LIVELLATORE	LEVELLING DEVICE	EQUILIBREUR	DISP. EQUILIBRADOR
65M	MASSA ANTICIPO	FLYWEIGHT	MASSELOTTE	CONTRAPESO
65T	TARGA	DECAL	DECALCOMANIE	CALCOMANIA

PART NUMBER	ITEM	KIT COMP. PART. N.	QTY	SGR.	TAV.	PAG.	GRID POS.	TRANS CODE	DESCRIPTION	DENOMINAZIONE
79055160										
	21	73118136	2	B2.01/ 1	6	1	1-T4	45A	RING	ANELLO
	27	73118167	1	B2.01/ 1	3	1	1-S4	123G	SEAL ASSY	GUARNIZIONE TENUTA FRONTALE
	24	79030210	1	B2.01/ 1	6	1	1-T4	123G	SEAL ASSY	GUARNIZIONE TENUTA FRONTALE
	17	79030211	1	B2.01/ 1	4	1	1-S2	123G	SEAL ASSY	GUARNIZIONE TENUTA FRONTALE
	19	79030215	1	B2.01/ 1	4	1	1-S2	158G	O-RING	GUARNIZIONE O-R
	21	79030217	1	B2.01/ 1	4	1	1-S2	158G	O-RING	GUARNIZIONE O-R
	26	79030266	1	B2.01/ 1	4	1	1-S2	123G	SEAL ASSY	GUARNIZIONE TENUTA FRONTALE
	7	79030268	2	B2.01/ 1	5	1	1-T3	123G	SEAL ASSY	GUARNIZIONE TENUTA FRONTALE
	9	79030270	1	B2.01/ 1	5	1	1-T3	158G	O-RING	GUARNIZIONE O-R
	37	79031003	1	B2.01/ 1	3	2	1-S3	158G	O-RING	GUARNIZIONE O-R
	23	79086375	1	B2.01/ 1	3	1	1-S4	122G	SEAL	GUARNIZIONE
79055160										
	12	14457180	2	B2.01/1A	1	1	1-T8	158G	O-RING	GUARNIZIONE O-R
	6	14458580	1	B2.01/1A	5	1	1-T14	158G	O-RING	GUARNIZIONE O-R
	12	14462980	3	B2.01/1A	2	1	1-T10	158G	O-RING	GUARNIZIONE O-R
	25	14463880	2	B2.01/1A	9	1	2-H4	158G	O-RING	GUARNIZIONE O-R
	13	71004848	1	B2.01/1A	1	1	1-T8	123G	SEAL ASSY	GUARNIZIONE TENUTA FRONTALE
	8	71005536	1	B2.01/1A	5	1	1-T14	158G	O-RING	GUARNIZIONE O-R
	16	73118040	1	B2.01/1A	2	1	1-T10	123G	SEAL ASSY	GUARNIZIONE TENUTA FRONTALE
	13	73118059	1	B2.01/1A	7	1	1-T17	45A	RING	ANELLO
	12	73118064	1	B2.01/1A	5	1	1-T14	122G	SEAL	GUARNIZIONE
	15	73118067	1	B2.01/1A	5	1	1-T14	158G	O-RING	GUARNIZIONE O-R
	10	73118086	5	B2.01/1A	11	1	2-H7	123G	SEAL ASSY	GUARNIZIONE TENUTA FRONTALE
	11	73118087	5	B2.01/1A	11	1	2-H7	123G	SEAL ASSY	GUARNIZIONE TENUTA FRONTALE
	15	73118096	4	B2.01/1A	9	1	2-H4	45A	RING	ANELLO
	9	73118117	2	B2.33/ A	1	1	2-I16	158G	O-RING	GUARNIZIONE O-R
	25	73118124	1	B2.01/1A	1	1	1-T8	123G	SEAL ASSY	GUARNIZIONE TENUTA FRONTALE
	21	73118136	2	B2.01/1A	9	1	2-H4	45A	RING	ANELLO
	27	73118167	1	B2.01/1A	1	1	1-T8	123G	SEAL ASSY	GUARNIZIONE TENUTA FRONTALE

PART NUMBER	ITEM	KIT COMP. PART. N.	QTY	SGR.	TAV.	PAG.	GRID POS.	TRANS CODE	DESCRIPTION	DENOMINAZIONE
79055160										
	9	73118117	2	B2.33/ A	1	1	2-I16	158G	O-RING	GUARNIZIONE O-R
	25	73118124	1	B2.01/ B	1	1	1-R10	123G	SEAL ASSY	GUARNIZIONE TENUTA FRONTALE
	21	73118136	2	B2.01/ B	9	1	1-S13	45A	RING	ANELLO
	27	73118167	1	B2.01/ B	1	1	1-R10	123G	SEAL ASSY	GUARNIZIONE TENUTA FRONTALE
	24	79030210	1	B2.01/ B	9	1	1-S13	123G	SEAL ASSY	GUARNIZIONE TENUTA FRONTALE
	17	79030211	1	B2.01/ B	2	1	1-R12	123G	SEAL ASSY	GUARNIZIONE TENUTA FRONTALE
	19	79030215	1	B2.01/ B	2	1	1-R12	158G	O-RING	GUARNIZIONE O-R
	21	79030217	1	B2.01/ B	2	1	1-R12	158G	O-RING	GUARNIZIONE O-R
	26	79030266	1	B2.01/ B	2	1	1-R12	123G	SEAL ASSY	GUARNIZIONE TENUTA FRONTALE
	7	79030268	2	B2.01/ B	3	1	1-R14	123G	SEAL ASSY	GUARNIZIONE TENUTA FRONTALE
	9	79030270	1	B2.01/ B	3	1	1-R14	158G	O-RING	GUARNIZIONE O-R
	37	79031003	1	B2.01/ B	1	2	1-R11	158G	O-RING	GUARNIZIONE O-R
	23	79086375	1	B2.01/ B	1	1	1-R10	122G	SEAL	GUARNIZIONE
79055160										
	12	14457180	2	B2.01/ 1	3	1	1-S4	158G	O-RING	GUARNIZIONE O-R
	6	14458580	1	B2.01/ 1	1	1	1-S8	158G	O-RING	GUARNIZIONE O-R
	12	14462980	3	B2.01/ 1	4	1	1-S2	158G	O-RING	GUARNIZIONE O-R
	25	14463880	2	B2.01/ 1	6	1	1-T4	158G	O-RING	GUARNIZIONE O-R
	13	71004848	1	B2.01/ 1	3	1	1-S4	123G	SEAL ASSY	GUARNIZIONE TENUTA FRONTALE
	8	71005536	1	B2.01/ 1	1	1	1-S8	158G	O-RING	GUARNIZIONE O-R
	16	73118040	1	B2.01/ 1	4	1	1-S2	123G	SEAL ASSY	GUARNIZIONE TENUTA FRONTALE
	13	73118059	1	B2.01/ 1	2	1	1-S6	45A	RING	ANELLO
	12	73118064	1	B2.01/ 1	1	1	1-S8	123G	SEAL ASSY	GUARNIZIONE TENUTA FRONTALE
	15	73118067	1	B2.01/ 1	1	1	1-S8	158G	O-RING	GUARNIZIONE O-R
	10	73118086	5	B2.01/ 1	7	1	1-T6	123G	SEAL ASSY	GUARNIZIONE TENUTA FRONTALE
	11	73118087	5	B2.01/ 1	7	1	1-T6	123G	SEAL ASSY	GUARNIZIONE TENUTA FRONTALE
	15	73118096	4	B2.01/ 1	6	1	1-T4	45A	RING	ANELLO
	9	73118117	2	B2.33	1	1	2-I17	158G	O-RING	GUARNIZIONE O-R
	25	73118124	1	B2.01/ 1	3	1	1-S4	123G	SEAL ASSY	GUARNIZIONE TENUTA FRONTALE

PART NUMBER	ITEM	KIT COMP. PART. N.	QTY	SGR.	TAV.	PAG.	GRID POS.	TRANS CODE	DESCRIPTION	DENOMINAZIONE
79055160										
	11	73118087	5	B2.01/ A	7	1	1-R8	123G	SEAL ASSY	GUARNIZIONE TENUTA FRONTALE
	15	73118096	4	B2.01/ A	6	1	1-R6	45A	RING	ANELLO
	9	73118117	2	B2.33/ A	1	1	2-116	158G	O-RING	GUARNIZIONE O-R
	25	73118124	1	B2.01/ A	3	1	1-R2	123G	SEAL ASSY	GUARNIZIONE TENUTA FRONTALE
	21	73118136	2	B2.01/ A	6	1	1-R6	45A	RING	ANELLO
	27	73118167	1	B2.01/ A	3	1	1-R2	123G	SEAL ASSY	GUARNIZIONE TENUTA FRONTALE
	24	79030210	1	B2.01/ A	6	1	1-R6	123G	SEAL ASSY	GUARNIZIONE TENUTA FRONTALE
	17	79030211	1	B2.01/ A	4	1	1-R4	123G	SEAL ASSY	GUARNIZIONE TENUTA FRONTALE
	19	79030215	1	B2.01/ A	4	1	1-R4	158G	O-RING	GUARNIZIONE O-R
	21	79030217	1	B2.01/ A	4	1	1-R4	158G	O-RING	GUARNIZIONE O-R
	26	79030266	1	B2.01/ A	4	1	1-R4	123G	SEAL ASSY	GUARNIZIONE TENUTA FRONTALE
	7	79030268	2	B2.01/ A	5	1	1-R5	123G	SEAL ASSY	GUARNIZIONE TENUTA FRONTALE
	9	79030270	1	B2.01/ A	5	1	1-R5	158G	O-RING	GUARNIZIONE O-R
	37	79031003	1	B2.01/ A	3	2	1-R3	158G	O-RING	GUARNIZIONE O-R
	23	79086375	1	B2.01/ A	3	1	1-R2	122G	SEAL	GUARNIZIONE
79055160										
	12	14457180	2	B2.01/ B	1	1	1-R10	158G	O-RING	GUARNIZIONE O-R
	6	14458580	1	B2.01/ B	5	1	1-R16	158G	O-RING	GUARNIZIONE O-R
	12	14462980	3	B2.01/ B	2	1	1-R12	158G	O-RING	GUARNIZIONE O-R
	25	14463880	2	B2.01/ B	9	1	1-S13	158G	O-RING	GUARNIZIONE O-R
	13	71004848	1	B2.01/ B	1	1	1-R10	123G	SEAL ASSY	GUARNIZIONE TENUTA FRONTALE
	8	71005536	1	B2.01/ B	5	1	1-R16	158G	O-RING	GUARNIZIONE O-R
	16	73118040	1	B2.01/ B	2	1	1-R12	123G	SEAL ASSY	GUARNIZIONE TENUTA FRONTALE
	13	73118059	1	B2.01/ B	7	1	1-S16	45A	RING	ANELLO
	12	73118064	1	B2.01/ B	5	1	1-R16	122G	SEAL	GUARNIZIONE
	15	73118067	1	B2.01/ B	5	1	1-R16	158G	O-RING	GUARNIZIONE O-R
	10	73118086	5	B2.01/ B	11	1	1-S10	123G	SEAL ASSY	GUARNIZIONE TENUTA FRONTALE
	11	73118087	5	B2.01/ B	11	1	1-S10	123G	SEAL ASSY	GUARNIZIONE TENUTA FRONTALE
	15	73118096	4	B2.01/ B	9	1	1-S13	45A	RING	ANELLO

PART NUMBER	ITEM	KIT COMP. PART. N.	QTY	SGR.	TAV.	PAG.	GRID POS.	TRANS CODE	DESCRIPTION	DENOMINAZIONE
79055160										
	15	73118067	1	B2.01	1	1	1-P17	158G	O-RING	GUARNIZIONE O-R
	10	73118086	5	B2.01	7	1	1-Q7	123G	SEAL ASSY	GUARNIZIONE TENUTA FRONTALE
	11	73118087	5	B2.01	7	1	1-Q7	123G	SEAL ASSY	GUARNIZIONE TENUTA FRONTALE
	15	73118096	4	B2.01	6	1	1-Q9	45A	RING	ANELLO
	9	73118117	2	B2.33	1	1	2-I17	158G	O-RING	GUARNIZIONE O-R
	25	73118124	1	B2.01	3	1	1-Q14	123G	SEAL ASSY	GUARNIZIONE TENUTA FRONTALE
	21	73118136	2	B2.01	6	1	1-Q9	45A	RING	ANELLO
	27	73118167	1	B2.01	3	2	1-Q13	123G	SEAL ASSY	GUARNIZIONE TENUTA FRONTALE
	24	79030210	1	B2.01	6	1	1-Q9	123G	SEAL ASSY	GUARNIZIONE TENUTA FRONTALE
	17	79030211	1	B2.01	4	1	1-Q12	123G	SEAL ASSY	GUARNIZIONE TENUTA FRONTALE
	19	79030215	1	B2.01	4	1	1-Q12	158G	O-RING	GUARNIZIONE O-R
	21	79030217	1	B2.01	4	1	1-Q12	158G	O-RING	GUARNIZIONE O-R
	26	79030266	1	B2.01	4	2	1-Q11	123G	SEAL ASSY	GUARNIZIONE TENUTA FRONTALE
	7	79030268	2	B2.01	5	1	1-Q10	123G	SEAL ASSY	GUARNIZIONE TENUTA FRONTALE
	9	79030270	1	B2.01	5	1	1-Q10	158G	O-RING	GUARNIZIONE O-R
	37	79031003	1	B2.01	3	2	1-Q13	158G	O-RING	GUARNIZIONE O-R
	23	79086375	1	B2.01	3	1	1-Q14	122G	SEAL	GUARNIZIONE
79055160										
	12	14457180	2	B2.01/ A	3	1	1-R2	158G	O-RING	GUARNIZIONE O-R
	6	14458580	1	B2.01/ A	1	1	1-Q5	158G	O-RING	GUARNIZIONE O-R
	12	14462980	3	B2.01/ A	4	1	1-R4	158G	O-RING	GUARNIZIONE O-R
	25	14463880	2	B2.01/ A	6	1	1-R6	158G	O-RING	GUARNIZIONE O-R
	13	71004848	1	B2.01/ A	3	1	1-R2	123G	SEAL ASSY	GUARNIZIONE TENUTA FRONTALE
	8	71005536	1	B2.01/ A	1	1	1-Q5	158G	O-RING	GUARNIZIONE O-R
	16	73118040	1	B2.01/ A	4	1	1-R4	123G	SEAL ASSY	GUARNIZIONE TENUTA FRONTALE
	13	73118059	1	B2.01/ A	2	1	1-Q3	45A	RING	ANELLO
	12	73118064	1	B2.01/ A	1	1	1-Q5	123G	SEAL ASSY	GUARNIZIONE TENUTA FRONTALE
	15	73118067	1	B2.01/ A	1	1	1-Q5	158G	O-RING	GUARNIZIONE O-R
	10	73118086	5	B2.01/ A	7	1	1-R8	123G	SEAL ASSY	GUARNIZIONE TENUTA FRONTALE

PART NUMBER	ITEM	KIT COMP. PART. N.	QTY	SGR.	TAV.	PAG.	GRID POS.	TRANS CODE	DESCRIPTION	DENOMINAZIONE
79055159										
	6	14458580	1	B2.01/	1	1	1-S8	158G	O-RING	GUARNIZIONE O-R
	8	71005536	1	B2.01/	1	1	1-S8	158G	O-RING	GUARNIZIONE O-R
	13	73118059	1	B2.01/	1	2	1-S6	45A	RING	ANELLO
	16	73118062	1	B2.01/	1	2	1-S6	100M	SPRING	MOLLA
	12	73118064	1	B2.01/	1	1	1-S8	123G	SEAL ASSY	GUARNIZIONE TENUTA FRONTALE
	15	73118067	1	B2.01/	1	1	1-S8	158G	O-RING	GUARNIZIONE O-R
	27	73118167	1	B2.01/	1	3	1-S4	123G	SEAL ASSY	GUARNIZIONE TENUTA FRONTALE
	15	79064451	1	B2.01/	1	2	1-S6	45A	RING	ANELLO
79055159										
	12	14457180	1	B2.01/1A	1	1	1-T8	158G	O-RING	GUARNIZIONE O-R
	6	14458580	1	B2.01/1A	5	1	1-T14	158G	O-RING	GUARNIZIONE O-R
	8	71005536	1	B2.01/1A	5	1	1-T14	158G	O-RING	GUARNIZIONE O-R
	13	73118059	1	B2.01/1A	7	1	1-T17	45A	RING	ANELLO
	16	73118062	1	B2.01/1A	7	1	1-T17	100M	SPRING	MOLLA
	12	73118064	1	B2.01/1A	5	1	1-T14	122G	SEAL	GUARNIZIONE
	15	73118067	1	B2.01/1A	5	1	1-T14	158G	O-RING	GUARNIZIONE O-R
	27	73118167	1	B2.01/1A	1	1	1-T8	123G	SEAL ASSY	GUARNIZIONE TENUTA FRONTALE
	15	79064451	1	B2.01/1A	7	1	1-T17	45A	RING	ANELLO
79055160										
	12	14457180	2	B2.01	3	1	1-Q14	158G	O-RING	GUARNIZIONE O-R
	6	14458580	1	B2.01	1	1	1-P17	158G	O-RING	GUARNIZIONE O-R
	12	14462980	3	B2.01	4	1	1-Q12	158G	O-RING	GUARNIZIONE O-R
	25	14463880	2	B2.01	6	1	1-Q9	158G	O-RING	GUARNIZIONE O-R
	13	71004848	1	B2.01	3	1	1-Q14	123G	SEAL ASSY	GUARNIZIONE TENUTA FRONTALE
	8	71005536	1	B2.01	1	1	1-P17	158G	O-RING	GUARNIZIONE O-R
	16	73118040	1	B2.01	4	1	1-Q12	123G	SEAL ASSY	GUARNIZIONE TENUTA FRONTALE
	13	73118059	1	B2.01	2	1	1-Q16	45A	RING	ANELLO
	12	73118064	1	B2.01	1	1	1-P17	123G	SEAL ASSY	GUARNIZIONE TENUTA FRONTALE

PART NUMBER	ITEM	KIT COMP. PART. N.	QTY	SGR.	TAV.	PAG.	GRID POS.	TRANS CODE	DESCRIPTION	DENOMINAZIONE
79055159										
	8	71005536	1	B2.01	1	1	1-P17	158G	O-RING	GUARNIZIONE O-R
	13	73118059	1	B2.01	2	1	1-Q16	45A	RING	ANELLO
	16	73118062	1	B2.01	2	1	1-Q16	100M	SPRING	MOLLA
	12	73118064	1	B2.01	1	1	1-P17	123G	SEAL ASSY	GUARNIZIONE TENUTA FRONTALE
	15	73118067	1	B2.01	1	1	1-P17	158G	O-RING	GUARNIZIONE O-R
	27	73118167	1	B2.01	3	2	1-Q13	123G	SEAL ASSY	GUARNIZIONE TENUTA FRONTALE
	15	79064451	1	B2.01	2	1	1-Q16	45A	RING	ANELLO
79055159										
	12	14457180	1	B2.01/ A	3	1	1-R2	158G	O-RING	GUARNIZIONE O-R
	6	14458580	1	B2.01/ A	1	1	1-Q5	158G	O-RING	GUARNIZIONE O-R
	8	71005536	1	B2.01/ A	1	1	1-Q5	158G	O-RING	GUARNIZIONE O-R
	13	73118059	1	B2.01/ A	2	1	1-Q3	45A	RING	ANELLO
	16	73118062	1	B2.01/ A	2	1	1-Q3	100M	SPRING	MOLLA
	12	73118064	1	B2.01/ A	1	1	1-Q5	123G	SEAL ASSY	GUARNIZIONE TENUTA FRONTALE
	15	73118067	1	B2.01/ A	1	1	1-Q5	158G	O-RING	GUARNIZIONE O-R
	27	73118167	1	B2.01/ A	3	1	1-R2	123G	SEAL ASSY	GUARNIZIONE TENUTA FRONTALE
	15	79064451	1	B2.01/ A	2	1	1-Q3	45A	RING	ANELLO
79055159										
	12	14457180	1	B2.01/ B	1	1	1-R10	158G	O-RING	GUARNIZIONE O-R
	6	14458580	1	B2.01/ B	5	1	1-R16	158G	O-RING	GUARNIZIONE O-R
	8	71005536	1	B2.01/ B	5	1	1-R16	158G	O-RING	GUARNIZIONE O-R
	13	73118059	1	B2.01/ B	7	1	1-S16	45A	RING	ANELLO
	16	73118062	1	B2.01/ B	7	1	1-S16	100M	SPRING	MOLLA
	12	73118064	1	B2.01/ B	5	1	1-R16	122G	SEAL	GUARNIZIONE
	15	73118067	1	B2.01/ B	5	1	1-R16	158G	O-RING	GUARNIZIONE O-R
	27	73118167	1	B2.01/ B	1	1	1-R10	123G	SEAL ASSY	GUARNIZIONE TENUTA FRONTALE
	15	79064451	1	B2.01/ B	7	1	1-S16	45A	RING	ANELLO
79055159										
	12	14457180	1	B2.01/ 1	3	1	1-S4	158G	O-RING	GUARNIZIONE O-R

FIATALLIS FD7

NTR. 205

30.09.91 - 60401081.06

PART NUMBER	ITEM	KIT COMP. PART. N.	QTY	SGR.	TAV.	PAG.	GRID POS.	TRANS CODE	DESCRIPTION	DENOMINAZIONE
79037439										
	4	4653283	1	A1.02	1	1	1-H9	123G	SEAL ASSY	GUARNIZIONE TENUTA FRONTALE
	5	4713071	1	A1.02	1	1	1-H9	123G	SEAL ASSY	GUARNIZIONE TENUTA FRONTALE
	6	4713072	1	A1.02	1	1	1-H9	123G	SEAL ASSY	GUARNIZIONE TENUTA FRONTALE
	23	14463880	1	A1.02	1	2	1-H10	158G	O-RING	GUARNIZIONE O-R
	24	14483080	1	A1.02	1	2	1-H10	158G	O-RING	GUARNIZIONE O-R
	19	40000010	1	A1.02	2	1	1-H11	158G	O-RING	GUARNIZIONE O-R
	30	40002810	1	A1.02	1	2	1-H10	158G	O-RING	GUARNIZIONE O-R
79037501										
	2	4679224	6	A1.05	1	1	1-H16	80P	PIN	PERNO
	3	4679226	6	A1.05	1	1	1-H16	50A	OILSCRAPER RING	ANELLO RASCHIAOLIO
	4	4679227	6	A1.05	1	1	1-H16	50A	OILSCRAPER RING	ANELLO RASCHIAOLIO
	5	4679272	6	A1.05	1	1	1-H16	53A	PISTON RING	ANELLO STANTUFFO
	23	4706866	6	A1.05	1	1	1-H16	235S	PISTON	STANTUFFO
	30	11059376	12	A1.05	1	2	1-H17	51A	LOCKRING	ANELLO DI SICUREZZA
79046186										
	2	4599560	1	A4.03	1	1	1-P8	123G	SEAL ASSY	GUARNIZIONE TENUTA FRONTALE
	2	4599561	1	A4.02	2	1	1-P3	123G	SEAL ASSY	GUARNIZIONE TENUTA FRONTALE
	3	4599562	1	A4.02	2	1	1-P3	123G	SEAL ASSY	GUARNIZIONE TENUTA FRONTALE
	4	4603870	1	A4.03	1	1	1-P8	158G	O-RING	GUARNIZIONE O-R
	6	4639097	1	A4.03	1	1	1-P9	60G	IMPELLER	GIRANTE
	7	4655011	1	A4.03	1	1	1-P8	16A	SHAFT	ALBERO
	6	4673810	1	A4.02	2	1	1-P3	123G	SEAL ASSY	GUARNIZIONE TENUTA FRONTALE
	9	13748610	1	A4.03	1	1	1-P8	40V	SCREW	VITE
	15	14462081	1	A4.02	2	2	1-P4	158G	O-RING	GUARNIZIONE O-R
79055159										
	12	14457180	1	B2.01	3	1	1-Q14	158G	O-RING	GUARNIZIONE O-R
	6	14458580	1	B2.01	1	1	1-P17	158G	O-RING	GUARNIZIONE O-R

9/ 7

F7

FIATALLIS FD7

NTR. 205

30.09.91 - 60401081.06

PART NUMBER	ITEM	KIT COMP. PART. N.	QTY	SGR.	TAV.	PAG.	GRID POS.	TRANS CODE	DESCRIPTION	DENOMINAZIONE
79023787	1	79023787	1	L4.10	1	1	3-M11	2K	KIT	KIT
79032513	3	70926813	2	E3.29	1	1	2-R7	158G	O-RING	GUARNIZIONE O-R
	6	73045975	1	E3.29	1	1	2-R7	133R	SEAL	ROSETTA DI TENUTA
	7	73045976	2	E3.29	1	1	2-R7	133R	SEAL	ROSETTA DI TENUTA
	8	73045977	4	E3.29	1	1	2-R7	341C	BEARING	CUSCINETTO
	10	79030475	2	E3.29	1	1	2-R7	70F	FLANGE	FLANGIA
79032514	3	70926813	2	E3.29	1	1	2-R7	158G	O-RING	GUARNIZIONE O-R
	6	73045975	1	E3.29	1	1	2-R7	133R	SEAL	ROSETTA DI TENUTA
79037380	4	4601390	1	A1.01	2	1	1-H5	123G	SEAL ASSY	GUARNIZIONE TENUTA FRONTALE
	6	4628453	1	A1.01	2	1	1-H5	123G	SEAL ASSY	GUARNIZIONE TENUTA FRONTALE
	5	4696355	1	A1.01	1	1	1-H4	123G	SEAL ASSY	GUARNIZIONE TENUTA FRONTALE
79037400	3	4690497	6	A1.05	1	1	1-H16	50A	OILSCRAPER RING	ANELLO RASCHIAOLIO
	4	4690502	6	A1.05	1	1	1-H16	50A	OILSCRAPER RING	ANELLO RASCHIAOLIO
	5	4707726	6	A1.05	1	1	1-H16	53A	PISTON RING	ANELLO STANTUFFO
79037439	1	4031577	1	A1.02	2	1	1-H11	123G	SEAL ASSY	GUARNIZIONE TENUTA FRONTALE
	1	4600893	1	A1.25	1	1	1-I3	123G	SEAL ASSY	GUARNIZIONE TENUTA FRONTALE
	1	4605564	2	A1.02	1	1	1-H9	123G	SEAL ASSY	GUARNIZIONE TENUTA FRONTALE
	2	4607590	1	A1.02	2	1	1-H11	123G	SEAL ASSY	GUARNIZIONE TENUTA FRONTALE
	3	4607638	1	A1.02	2	1	1-H11	123G	SEAL ASSY	GUARNIZIONE TENUTA FRONTALE
	4	4607639	1	A1.02	2	1	1-H11	123G	SEAL ASSY	GUARNIZIONE TENUTA FRONTALE

9/ 6

F8

PART NUMBER	ITEM	KIT COMP. PART. N.	QTY	SGR.	TAV.	PAG.	GRID POS.	TRANS CODE	DESCRIPTION	DENOMINAZIONE
76015041										
	1	79086895	37	D3.40/ A	1	1	2-N7	145M	TRACK LINK	MAGLIA CINGOLO
	3	79086896	1	D3.40/ A	1	1	2-N7	145M	TRACK LINK	MAGLIA CINGOLO
	4	79086897	1	D3.40/ A	1	1	2-N7	145M	TRACK LINK	MAGLIA CINGOLO
	2	79086898	38	D3.40/ A	2	1	2-N8	80P	PIN	PERNO
	3	79086899	38	D3.40/ A	2	1	2-N8	95B	BUSHING	BOCCOLA
	4	79086900	76	D3.40/ A	2	1	2-N8	75D	SPACER	DISTANZIALE
	5	79086901	76	D3.40/ A	2	1	2-N8	122G	SEAL	GUARNIZIONE
	1	79086902	38	D3.40/ A	2	1	2-N8	50T	PLUG	TAPPO
76019926										
	5	76019926	1	L1.30/ 1	1	1	3-L8	1K	KIT SEE PAGE 9	KIT VED. PAG.9
79022484										
	12	79022484	1	F3.03/ 1	1	1	2-T4	2K	KIT	KIT
79022484										
	12	79022484	1	F3.03/ 1A	1	1	2-T5	2K	KIT	KIT
79023782										
	1	79023782	1	L4.10	1	1	3-M11	2K	KIT	KIT
79023783										
	1	79023783	1	L4.10	1	1	3-M11	2K	KIT	KIT
79023784										
	1	79023784	1	L4.10	1	1	3-M11	2K	KIT	KIT
79023785										
	1	79023785	1	L4.10	1	1	3-M11	2K	KIT	KIT
79023786										
	1	79023786	1	L4.10	1	1	3-M11	2K	KIT	KIT

FIATALLIS FD7

NTR. 205

30.09.91 - 60401081.06

PART NUMBER	ITEM	KIT COMP. PART. N.	QTY	SGR.	TAV.	PAG.	GRID POS.	TRANS CODE	DESCRIPTION	DENOMINAZIONE
8281576										
	1	5110478	2	D2.27/	A	1	2-M11	123G	SEAL ASSY	GUARNIZIONE TENUTA FRONTALE
	2	8273909	2	D2.27/	A	1	2-M11	158G	O-RING	GUARNIZIONE O-R
	20	14460380	2	D2.27/	A	1	2-M11	158G	O-RING	GUARNIZIONE O-R
73153575										
	5	73153575	1	L1.30/	1	1	3-L8	1K	KIT SEE PAGE 9	KIT VED. PAG.9
76015040										
	8	76008353	148	D3.40/	A	1	2-N7	40V	SCREW	VITE
	10	76008354	148	D3.40/	A	1	2-N7	10D	NUT	DADO
	9	76015201	2	D3.40/	A	1	2-N7	40V	SCREW	VITE
	9	76015987	2	D3.40/	A	1	2-N7	40V	SCREW	VITE
	6	79026835	38	D3.40/	A	1	2-N7	295S	SHOE	SUOLA
	2	79086894	37	D3.40/	A	1	2-N7	145M	TRACK LINK	MAGLIA CINGOLO
	1	79086895	37	D3.40/	A	1	2-N7	145M	TRACK LINK	MAGLIA CINGOLO
	3	79086896	1	D3.40/	A	1	2-N7	145M	TRACK LINK	MAGLIA CINGOLO
	4	79086897	1	D3.40/	A	1	2-N7	145M	TRACK LINK	MAGLIA CINGOLO
	2	79086898	38	D3.40/	A	2	2-N8	80P	PIN	PERNO
	3	79086899	38	D3.40/	A	2	2-N8	95B	BUSHING	BOCCOLA
	4	79086900	76	D3.40/	A	2	2-N8	75D	SPACER	DISTANZIALE
	5	79086901	76	D3.40/	A	2	2-N8	122G	SEAL	GUARNIZIONE
	1	79086902	38	D3.40/	A	2	2-N8	50T	PLUG	TAPPO
76015041										
	8	76008353	148	D3.40/	A	1	2-N7	40V	SCREW	VITE
	10	76008354	148	D3.40/	A	1	2-N7	10D	NUT	DADO
	9	76015201	2	D3.40/	A	1	2-N7	40V	SCREW	VITE
	9	76015987	2	D3.40/	A	1	2-N7	40V	SCREW	VITE
	6	79026832	38	D3.40/	A	1	2-N7	295S	SHOE	SUOLA
	2	79086894	37	D3.40/	A	1	2-N7	145M	TRACK LINK	MAGLIA CINGOLO

9/ 4

F10

FIATALLIS FD7

NTR. 205

30.09.91 - 60401081.06

PART NUMBER	ITEM	KIT COMP. PART. N.	QTY	SGR.	TAV.	PAG.	GRID POS.	TRANS CODE	DESCRIPTION	DENOMINAZIONE
1930183	16	1930183	1	A1.05/ A	1	1	1-117	2K	KIT	KIT
1930184	16	1930184	1	A1.05/ A	1	1	1-117	2K	KIT	KIT
1930185	16	1930185	1	A1.05/ A	1	1	1-117	2K	KIT	KIT
1930186	2	1930186	1	A1.05/ A	1	1	1-117	2K	KIT	KIT
1930188	2	1930188	1	A1.05/ A	1	1	1-117	2K	KIT	KIT
1930190	2	1930190	1	A1.05/ A	1	1	1-117	2K	KIT	KIT
1930191	3	1930191	1	A1.05/ A	1	1	1-117	2K	KIT	KIT
1930193	3	1930193	1	A1.05/ A	1	1	1-117	2K	KIT	KIT
1930195	3	1930195	1	A1.05/ A	1	1	1-117	2K	KIT	KIT
8281576	1	5110478	2	D2.27	1	1	2-M12	123G	SEAL ASSY	GUARNIZIONE TENUTA FRONTALE
	2	8273909	2	D2.27	1	1	2-M12	158G	O-RING	GUARNIZIONE O-R
	20	14460380	2	D2.27	1	1	2-M12	158G	O-RING	GUARNIZIONE O-R

PART NUMBER	ITEM	KIT COMP. PART. N.	QTY	SGR.	TAV.	PAG.	GRID POS.	TRANS CODE	DFSCRIPTION	DENOMINAZIONE
1901805	7	4738348	1	A1.03	1	1	1-H13	103S	HALF BEARING	SEMICUSCINETTO
1909234	3	4679226	1	A1.05	1	1	1-H16	50A	OILSCRAPER RING	ANELLO RASCHIAOLIO
	4	4679227	1	A1.05	1	1	1-H16	50A	OILSCRAPER RING	ANELLO RASCHIAOLIO
	5	4679272	1	A1.05	1	1	1-H16	53A	PISTON RING	ANELLO STANTUFFO
1909242	3	4690498	1	A1.05	1	1	1-H16	50A	OILSCRAPER RING	ANELLO RASCHIAOLIO
	4	4690503	1	A1.05	1	1	1-H16	50A	OILSCRAPER RING	ANELLO RASCHIAOLIO
	5	4707727	1	A1.05	1	1	1-H16	53A	PISTON RING	ANELLO STANTUFFO
1930176	7	1930176	1	A1.03/ A	1	1	1-H14	2K	KIT	KIT
1930177	7	1930177	1	A1.03/ A	1	1	1-H14	2K	KIT	KIT
1930178	7	1930178	1	A1.03/ A	1	1	1-H14	2K	KIT	KIT
1930179	7	1930179	1	A1.03/ A	1	1	1-H14	2K	KIT	KIT
1930180	7	1930180	1	A1.03/ A	1	1	1-H14	2K	KIT	KIT
1930181	16	1930181	1	A1.05/ A	1	1	1-H17	2K	KIT	KIT
1930182	16	1930182	1	A1.05/ A	1	1	1-H17	2K	KIT	KIT

PART NUMBER	ITEM	KIT COMP. PART. N.	QTY	SGR.	TAV.	PAG.	GRID POS.	TRANS CODE	DESCRIPTION	DENOMINAZIONE
775013										
	1	775597		A2.35/ A	1	2	1-N12	198S	SHIM	SPESSORE
	1	775598		A2.35/ A	1	2	1-N12	198S	SHIM	SPESSORE
	1	775599		A2.35/ A	1	2	1-N12	198S	SHIM	SPESSORE
	1	775600		A2.35/ A	1	2	1-N12	198S	SHIM	SPESSORE
	1	775601		A2.35/ A	1	2	1-N12	198S	SHIM	SPESSORE
1901385										
	1	1901385	1	A1.03/ A	1	1	1-H14	2K	KIT	KIT
1901386										
	1	1901386	1	A1.03/ A	1	1	1-H14	2K	KIT	KIT
1901387										
	1	1901387	1	A1.03/ A	1	1	1-H14	2K	KIT	KIT
1901388										
	1	1901388	1	A1.03/ A	1	1	1-H14	2K	KIT	KIT
1901609										
	17	4698677	.2	A1.05	1	1	1-H16	103S	HALF BEARING	SEMICUSCINETTO
1901803										
	3	4698683	1	A1.03	1	1	1-H13	103S	HALF BEARING	SEMICUSCINETTO
	7	4738345	1	A1.03	1	1	1-H13	103S	HALF BEARING	SEMICUSCINETTO
1901804										
	3	4698685	1	A1.03	1	1	1-H13	103S	HALF BEARING	SEMICUSCINETTO
	7	4738347	1	A1.03	1	1	1-H13	103S	HALF BEARING	SEMICUSCINETTO
1901805										
	3	4698686	1	A1.03	1	1	1-H13	103S	HALF BEARING	SEMICUSCINETTO





KIT INDEX - INDICE DEI KITS - LISTE DES KITS - VERZEICHNIS DER ERSATZTEILSETZE - INDICE DE FORNITURAS

PART NUMBER	ITEM	KIT COMP. PART. N.	QTY	SGR.	TAV.	PAG.	GRID POS.	TRANS CODE	DESCRIPTION	DENOMINAZIONE
775013										
	1	772799		A2.35/	A	1	1-N11	198S	SHIM	SPESSORE
	1	772800		A2.35/	A	1	1-N11	198S	SHIM	SPESSORE
	1	772801		A2.35/	A	1	1-N11	198S	SHIM	SPESSORE
	1	772802		A2.35/	A	1	1-N11	198S	SHIM	SPESSORE
	1	772803		A2.35/	A	1	1-N11	198S	SHIM	SPESSORE
	1	772804		A2.35/	A	1	1-N11	198S	SHIM	SPESSORE
	1	772805		A2.35/	A	1	1-N11	198S	SHIM	SPESSORE
	1	775014		A2.35/	A	1	1-N11	198S	SHIM	SPESSORE
	1	775015		A2.35/	A	1	1-N11	198S	SHIM	SPESSORE
	1	775016		A2.35/	A	1	1-N11	198S	SHIM	SPESSORE
	1	775017		A2.35/	A	1	1-N11	198S	SHIM	SPESSORE
	1	775018		A2.35/	A	1	1-N11	198S	SHIM	SPESSORE
	1	775019		A2.35/	A	1	1-N11	198S	SHIM	SPESSORE
	1	775025		A2.35/	A	1	1-N11	198S	SHIM	SPESSORE
	1	775026		A2.35/	A	1	1-N11	198S	SHIM	SPESSORE
	1	775027		A2.35/	A	1	1-N11	198S	SHIM	SPESSORE
	1	775028		A2.35/	A	1	1-N11	198S	SHIM	SPESSORE
	1	775029		A2.35/	A	1	1-N11	198S	SHIM	SPESSORE
	1	775030		A2.35/	A	1	1-N11	198S	SHIM	SPESSORE
	1	775031		A2.35/	A	1	1-N11	198S	SHIM	SPESSORE
	1	775032		A2.35/	A	1	1-N11	198S	SHIM	SPESSORE
	1	775589		A2.35/	A	2	1-N12	198S	SHIM	SPESSORE
	1	775590		A2.35/	A	2	1-N12	198S	SHIM	SPESSORE
	1	775591		A2.35/	A	2	1-N12	198S	SHIM	SPESSORE
	1	775592		A2.35/	A	2	1-N12	198S	SHIM	SPESSORE
	1	775593		A2.35/	A	2	1-N12	198S	SHIM	SPESSORE
	1	775594		A2.35/	A	2	1-N12	198S	SHIM	SPESSORE
	1	775595		A2.35/	A	2	1-N12	198S	SHIM	SPESSORE
	1	775596		A2.35/	A	2	1-N12	198S	SHIM	SPESSORE

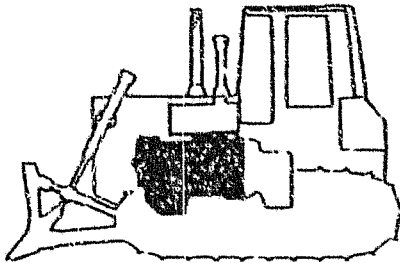
FD 7

PARTS FOR CURRENT MAINTENANCE (500 Hr KIT) P/N 77903554
RICAMBI PER MANUTENZIONE ORDINARIA (KIT 500 ORE)





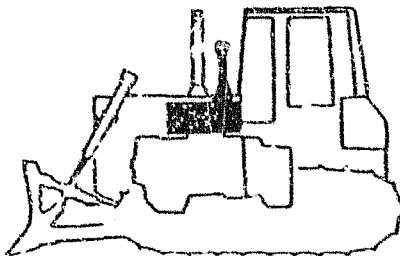

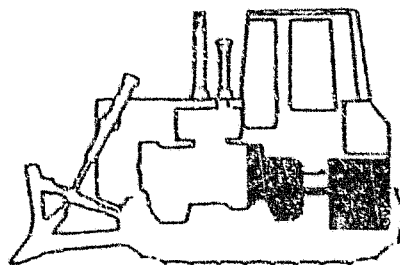

		SGR.A2.26/A Tav. 1 Item 1 (x2)			SGR.A3.01 Tav. 1A Item 8 (x2)
From serial N. 250905 Engine 8065.05.295		Dal telaio N. Motore			



		SGR.A2.23 Tav. 1 Item 6			
---	---	-------------------------	--	--	--



		SGR.B2.01/A Tav. 3 Item 29 (x2)			SGR.D2.24 Tav. 1 Item 9
		SGR.B2.01/A Tav. 3 Item 13		OR	SGR.D2.23 Tav. 1 Item 16

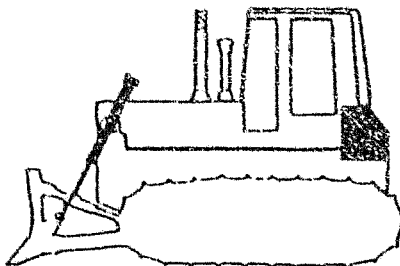

		SGR.E3.28 Tav. 1 Item 27		OR	SGR.E3.28 Tav. 1 Item 14
---	---	--------------------------	---	----	--------------------------

ITEM	PART N.	GRID	ITEM	PART N.	GRID	ITEM	PART N.	GRID	ITEM	PART N.	GRID	ITEM	PART N.	GRID
2	79082100	1-N3	6	79086892	2-N8	1	79099724	2-L11						
5	79082102	1-M2	2	79086894	2-N7	28	79099767	2-L16						
13	79082103	1-M2	1	79086895	2-N7	21	79101480	2-T10						
10	79082104	1-M2	3	79086896	2-N7	33	79102227	1-R17						
7	79082105	1-M3	4	79086897	2-N7	33	79102227	1-T15						
1	79082106	1-N2	2	79086898	2-N8	20	79102690	1-R12						
11	79082107	1-M3	3	79086899	2-N8	20	79102690	1-T10						
3	79082108	1-N3	4	79086900	2-N8	2	79103405	2-R5						
11	79082109	1-M2	5	79086901	2-N6	29	79104646	1-R11						
14	79083842	1-P7	1	79086902	2-N8	29	79104646	1-T9						
9	79083842	3-I5	8	79087039	2-M3	15	79106765	1-M2						
13	79083844	2-L15	21	79087422	2-L14	5	79108165	1-M2						
6	79083844	2-M17	11	79089081	2-N7	3	79111658	1-R16						
13	79083845	1-P4	5	79089109	2-N7	3	79111658	1-T14						
14	79083846	1-P2	12	79089110	2-N7	6	98417182	1-P6						
14	79083846	1-P4	19	79092235	2-R14	1	98426137	1-H2						
14	79083846	2-N14	12	79093005	2-S15									
11	79083846	2-N16	20	79093005	2-S13									
10	79083849	1-L10	15	79093739	2-S17									
11	79083850	1-L10	24	79093835	2-R6									
29	79083851	1-L9	24	79094062	2-L16									
15	79084752	1-I2	3	79094063	2-L15									
32	79086374	1-R17	7	79094179	2-L12									
32	79086374	1-T15	16	79094495	1-M2									
23	79086375	1-Q14	19	79094771	2-L15									
23	79086375	1-R2	20	79096891	2-M10									
23	79086375	1-R10	18	79096891	2-M10									
23	79086375	1-S4	5	79099275	2-O6									
23	79086375	1-T8	5	79099275	2-P2									
25	79086428	1-L9	5	79099275	2-P5									
18	79086428	1-O14	14	79099276	2-R17									
15	79086428	1-O13	3	79099277	2-R17									
23	79086428	1-P2	11	79099278	2-R17									
22	79086428	1-P5	22	79099399	2-L16									
1	79086485	1-M2	23	79099401	2-L16									

ITEM	PART N.	GRID	ITEM	PART N.	GRID	ITEM	PART N.	GRID	ITEM	PART N.	GRID	ITEM	PART N.	GRID
26	79061879	2-I9	4	79065558	2-R13	28	79070380	2-T9	14	79073819	3-H3	17	79074712	2-T5
19	79062223	2-L4	2	79065559	2-R13	26	79070381	2-T3	13	79073822	2-T15	18	79074713	2-T4
31	79062511	1-H10	4	79065560	2-S15	16	79070383	2-T3	13	79073822	2-T17	18	79074713	2-T5
20	79062511	1-H12	5	79065560	2-S14	27	79070385	2-T3	19	79073822	3-H3	23	79074714	2-T4
9	79062511	1-I3	3	79065561	2-S15	16	79071307	2-S16	14	79073823	2-T15	23	79074714	2-T5
20	79062512	1-H6	4	79065561	2-S14	13	79071319	2-S15	14	79073823	2-T17	5	79074715	2-T4
30	79062512	1-H8	1	79065562	2-S15	21	79071319	2-S13	20	79073823	3-H3	5	79074715	2-T5
2	79062584	2-S5	2	79065562	2-S14	8	79071368	1-M2	15	79073824	2-T15	22	79075883	2-T4
1	79062723	2-M15	7	79065569	2-S17	7	79071369	1-M2	15	79073824	2-T17	22	79075883	2-T5
8	79062734	3-H12	10	79065570	2-S17	16	79071371	1-M2	21	79073824	3-H3	16	79076344	2-T9
2	79063942	1-R6	2	79065571	2-S17	5	79071372	1-M3	16	79073825	2-T15	19	79076598	2-Q17
2	79063942	1-S13	15	79066478	2-T8	4	79071375	1-M3	16	79073825	2-T17	16	79077026	1-I9
2	79063942	2-H4	20	79066594	2-M14	3	79071376	1-M3	22	79073825	3-H4	10	79077601	1-M3
30	79064245	1-R7	1	79067856	1-N14	2	79071377	1-M3	12	79074024	1-M2	8	79077602	1-M3
30	79064245	1-S12	17	79069460	2-T15	1	79071378	1-M3	12	79074027	1-M3	3	79077633	2-L11
30	79064245	2-H5	12	79069460	2-T17	9	79071380	1-M3	1	79074030	1-N3	3	79078988	2-Q7
11	79064264	1-P15	23	79069460	3-H4	3	79071383	1-N2	20	79074702	2-T4	4	79078990	2-P10
11	79064265	1-P15	3	79069496	1-M8	4	79071384	1-N2	20	79074702	2-T5	4	79078990	2-P11
10	79064308	3-L7	6	79069718	1-M12	5	79071385	1-N2	3	79074704	2-T4	4	79078990	2-Q17
35	79064449	1-Q2	7	79069734	1-M12	7	79071386	1-N2	3	79074704	2-T5	21	79078991	2-Q7
43	79064449	1-R9	1	79069735	1-N19	8	79071387	1-N2	8	79074705	2-T4	13	79079957	2-S9
35	79064449	1-S15	6	79069895	2-T15	9	79071388	1-N2	8	79074705	2-T5	18	79080111	2-T15
43	79064449	1-S9	8	79069895	2-T17	11	79071392	1-N3	19	79074706	2-T4	17	79080111	2-T17
35	79064449	2-H2	11	79069895	3-H3	5	79071396	1-N3	19	79074706	2-T5	24	79080111	3-H4
43	79064449	2-H8	7	79069896	2-T15	7	79071398	1-N3	13	79074707	2-T4	4	79080373	2-S6
15	79064451	1-Q16	9	79069896	2-T17	6	79071400	1-M3	13	79074707	2-T5	7	79080375	2-S6
15	79064451	1-Q3	12	79069896	3-H3	6	79071400	1-M2	14	79074708	2-T4	3	79080376	2-S6
15	79064451	1-S16	8	79070321	2-T15	6	79071400	1-N2	14	79074708	2-T5	1	79081044	2-S6
15	79064451	1-S6	10	79070321	2-T17	6	79071400	1-N3	10	79074709	2-T4	5	79081045	2-S6
15	79064451	1-T17	13	79070321	3-H3	20	79071471	2-R14	10	79074709	2-T5	6	79081046	2-S6
9	79064455	1-S16	7	79070373	2-T3	17	79072543	2-T9	21	79074710	2-T4	8	79081047	2-S6
9	79064455	1-T17	13	79070374	2-T3	12	79073031	2-T12	21	79074710	2-T5	15	79081900	2-T9
18	79065193	1-R12	20	79070377	2-T3	13	79073033	2-T12	11	79074711	2-T4	4	79082097	1-N3
39	79065194	1-S9	29	79070378	2-T3	9	79073819	2-T15	11	79074711	2-T5	9	79082098	1-N3
6	79065557	2-R13	21	79070379	2-T3	11	79073819	2-T17	17	79074712	2-T4	10	79082099	1-N3

DESIGNAZIONE BASE	BASIC DESIGNATION	DESIGNATIONS-BASES	GRUNDBEZEICHNUNGEN	DENOMINACIONES BASE
78F	FODERA	LINING	HOUSSE	FORRO
78I	INVERSORE	REVERSER	INVERSEUR	INVERSOR
78P	PER	FOR ...	POUR ...	PARA ...
780	DIAGNOSTICA CENTRALIZZATA	DIAGNOSTIC		
79A	ARRESTO ELASTICO	ELASTIC STOP	BUTEE DE TIGE	TOPE ELASTICO
79B	BLOCCETTO A SNODO	SWIVEL	TAQUET OSCILLANT	DADO OSCILANTE
79D	DISTRIBUTORE FRENO MOTORE	COASTER BRAKE CONTROL VALVE	DISTRIBUTEUR DE FREIN SUR ECHAPPEMENT	DISTRIBUIDOR DEL FRENO MOTOR
79D				
79I	HYPERBLOC	HYPERBLOC	HYPERBLOC	HYPERBLOC
79L	LUNETTA	REST	LUNETTE	SOMBRETE
80A	ARRESTO	STOP	BUTEE	TOPE
80D	DISTRIBUTORE DI ACCESIONE	IGNITION DISTRIBUTOR	ALLUMEUR	DISTRIBUIDOR DE ENCENDIDO
80D				
80F	FONDELLO	BOTTOM PLATE	BOUJ	TAPA
80G	GOCCIOLATOIO	TROUGH	GOUTTIERE	GOTERA
80L	LUCE ROTANTE	ROTARY BEACON	FEU TOURNANT	LAMPARA GIRATORIA
80M	MENSOLA	BRACKET	CONSOLE	MENSULA
80P	PERNO	PIN	AXE	PERNIO
80R	RIPARO SOLE	SUN VISOR	PARE-SOLEIL	PARASOL
80S	SEDILE	SEAT	SIEGE	ASIENITO
80T	TEMPORIZZATORE	TIMER	TEMPORISATEUR	TEMPORIZATOR
807	ALBERO PRESA DI FORZA	*POWER TAKE OFF SHAFT	ARBRE PRISE DE FORCE	ARBOI. TOMA DE FUERZA
81A	ARCONI	C-FRAME	ETRIER	ARCON
81D	DISTRIBUTORE ROTANTE	ROTATING DISTRIBUTOR	DISTRIBUTEUR TOURNANT	DISTRIBUIDOR GIRATORIO
81L	LUCCHETTO	PADLOCK	CADENAS	CANDADO
81P	PERNO DI FISSAGGIO	SECURING PIN	CHEVILLE	PASADOR
815	IMP.IDR.COM.DISTANZA-3CASSETTI	REMOTE HYDR SYST -3 SPOOLS	SYST HYDR A DIST -3 TIROIRS	SISTEMA HYDR PARA MANDO DIST
816	IMP.IDR.COM.DISTANZA-4 CASS	REMOTE HYDR SYST -4 SPOOLS	SYST HYDR A DIST - 4 TIROIRS	
819	SENZA IMPIANTO IDRAULICO	HYDRAULIC SYSTEM DEDUCTION	SANS SYSTEME HYDRAULIQUE	SIN SISTEMA HIDRAULICO
82B	BLOCCETTO SERRATURA	LOCK CYLINDER	BARILLETS DE SERRURE	BLOQUETE CERRADURA
82D	DISTRIBUTORE TRIPLEX	TRIPLEX DISTRIBUTOR	DISTRIBUTEUR TRIPLEX	DISTRIBUIDOR TRIPLEX
82D				
82L	LAMA ALL-HYDRAULIC	ALL-HYDRAULIC MOLDBOARD	LAME ALL-HYDRAULIC	HOJA ALL-HYDRAULIC
824	DISTRIBUTORE 3 CASSETTI	3 SPOOL VALVE	DISTRIBUTEUR A 3 TIROIRS	DISTRIBUIDOR DE 3 CARRETES
829	RIPARO CUFFIA RINFORZATO	RADIATOR GUARD H D	PROTECTION RENFORCEE RADIATEUR	
83A	ARPIONE	RATCHET	CLIQUET	ARPON
83B	BOBINA	COIL	BOBINE	BOBINA
83C	CARRUCOLA	SHEAVE	POULIE	POLEA
83D	DISTRIBUTORE	CONTROL VALVE	DISTRIBUTEUR	DISTRIBUIDOR

DESIGNAZIONE BASE	BASIC DESIGNATION	DESIGNATIONS-BASES	GRUNDEZEICHNUNGEN	DENOMINACIONES BASE	
73I	INTELAIATURA DEL TETTO	ROOF FRAME	CHASSIS DE TOIT	DACHRAHMEN	BASTIDOR DEL TECHO
73S	SEDE DELLA FUNE	EQUALIZER	EQUILIBREUR	SEILAUSGLEICHER	BALANCON
736	PREDISPOSIZIONE BATTERIE SAE	SAE BATTERIES PROVISION	PREDISP. BATTERIES SAE	BATTERIEHALTERUNG(NACH SAE)	ANCLAJES PARA BATERIAS SAE
74A	APPOGGIABRACCIA	ARMREST	ACCOUDOIR	ARMLEHNE	APOYABRAZOS
74B	BLOCCHETTO	BLOCK	TAQUET	PLATTE	BLOQUETE
74I	INTERRUTTORE TERMOMETRICO	THERMOSTATIC SENDING UNIT	THERMO-CONTACT	WAERMESCHALTER	INTERRUPTOR TERMO- STATICO
74I					
74S	SEDE DELLA VALVOLA	VALVE SEAT	SIEGE DE SOUPAPE	VENTILSITZ	ASIEN TO DE VALVOLA
742	SENZA BATTERIE	BATTERIES DEDUCTION	SANS BATTERIES	OHNE BATTERIE	SIN BATERIA
743	ATTIVAZIONE BATTERIE	BATTERIES ACTIVATION	ACTIVATION BATTERIE	BATTERIEFUELLUNG	
748	BATTERIE MAGGIORATE	HIGH CAPACITY BATTERIES	BATTERIES A HAUTE CAPACITE	HOCHLEISTUNGSBATTERIEN	
749	LUCI PER CIRCOLAZIONE STRADALE	ROAD TRAFFIC LIGHTS			
75B	BLOCCHETTO CONNESSIONE	CONNECTOR	PLAQUE DE JONCTION	VERBINDUNGSPLATTE	BLOQUETE DE EMPALME
75D	DISTANZIALE	SPACER	ENTRETOISE	DISTANZSTUECK	ESFACIADOR
75F	FLOTTANTE	CARRIER	FLOTTEUR	VENTILTRAEGER	VALVOLA FLOTANTE
75G	GLIFO	LINK	COULISSE	KLISSE	CORREDERA
75I	INTERRUTTORE	SWITCH	INTERRUPTEUR	SCHALTER	INTERRUPTOR
75M	MEMBRANA	DIAPHRAGM	MEMBRANE	MEMBRANE	MEMBRANA
75P	PENNELLO	PAINTBRUSH	PINCEAU	PINSEL	BROCHA
75S	SEDE SFERICA	BALL SOCKET	EMPLACEMENT SPHERIQUE	KUGELPFANNE	COJINETE E. FERICO
75T	TELA	FABRIC	TISSU	BEZUG	LONA
755	SENZA PROIETTORE	LIGHT DEDUCTION	SANS PROJECTEUR	OHNE SCHEINWERFER	SIN PROYECTOR
758	PROIETTORI POSTERIORI	REAR FLOODLIGHT	PROJECTEUR ARRIER	SCHEINWERFER HINTER	PROYECTORES POSTERIOR
759	PREDISPOSIZIONE BACK-ALARM	JACK UP ALARM PROVISION	BACK UP ALARM SANS AVERTISSEU	WARN RUECKWAERTS OHNE HUPE	BACK UP ALARM SIN BOCINA
76B	BLOCCHETTO ISOLANTE	INSULATING BLOCK	BLOC ISOLANT	ISOLIERPLATTE	BLOQUETE AISIADOR
76T	TELONE	TARPAULIN	BACHE	PLANE	TOLDO
76D	AVVISATORE ACUSTICO DI R M	BACK UP ALARM	BACK UP ALARM	WARNEINRICHTUNG RUECKWAERTS	BACK UP ALARM
752	LUCI DI INGOMBRO	OVERALL SIZE LIGHTS			
765	PROIETTORI PER ROPS	ROPS FLOODLIGHTS	PROJECTEUR POUR ROPS	SCHEINWERFER FUER ROPS	PROYECTORES PARA ROPS
766	PROIETTORI ANTERIORI	FRONT FLOODLIGHT	PROJECTEURS AVANT	FRONTSCHWEINWERFER	PROYECTORES ANTERIOR
767	PROIETTORI PER CABINA	CAB FLOODLIGHTS	PROJECTEURS POUR CABINE	SCHEINWERFER FUER KABINE	PROYECTORES PARA CABINA
768	CATADIOPTRI E DISCO VELOCITA	REFLECT AND SPEED LIMIT DECAL	CATADIOPTRE ET DISQUE VITESSE	RUECKSTRAHLER MIT TACHOSCHEIBE	
769	FANALI DIREZIONE LATERALE	TURN SIGNAL LIGHTS	CLIGNOTANTS DE DIRECTION	BLINKLICHT	SENALES DE DIRECCION
77B	BLOCCHETTO SERRAFILO	TERMINAL BLOCK	SERRE-FILS	NIPPEL	SUJETADOR
77T	TELAIO TRATTORE	MAIN FRAME	CHASSIS TRACTEUR	RAHMEN	ARMAZON DE TRACTOR
78A	APPOGGIAPIEDE	FOOTREST	REPOSE-PIEDS	FUSSRASTE	APOYAPIE
78B	BLOCCHETTO DI FISSAGGIO	FASTENING BLOCK	TAQUET DE FIXATION	SPANNSTUECK	MULETILLA DE FIJACION
78B					
78D	DISTRIBUTORE FRENI	BRAKE CONTROL VALVE	DISTRIBUTEUR DE FREINS	BREMSVENTIL	VALVOLA DISTRIBUI- DURA DE FRENOS
78D					

DESIGNAZIONE BASE	BASIC DESIGNATION	DESIGNATIONS-BASES	GRUNDBEZEICHNUNGEN	DENOMINACIONES BASE	
66C 66C 66F	CAPPUCCIO PARAPOLVERE FILTRO ARIA	DUST CAP AIR CLEANER	CAPUCHON CACHE- POUSSIERE FILTRE A AIR	STAUBSCHUTZKAPPE LUFTFILTER	CAPUCHON GUARDA- POLVO FILTRO DE AIRE
66G 67F 67G	GIUNTO OMOCINETICO FILTRO OLIO GIUNTO	CONSTANT VELOCITY UNIV.JOINT OIL FILTER COUPLING	JOINT HOMOCINETIQUE FILTRE A HUILE COUPLER	HOMOKINETISCHES GELENK OELFILTER GELENK	JUNTA HOMOCINETICA FILTRO DE ACEITE ACOPLAMIENTO
67N 67S 68F 68F 68F	MASSA CENTRIFUGA SEDE DENTE BENNA FILTRI OLIO E SCAMBIATORI CA- LORE	FLYWEIGHT BUCKET TOOTH SEAT OIL FILTER AND HEAT EXCHANGERS	MASSELOTTE EMPLACEMENT DENT DE GODET FILTRIS HUILE ET ECHANG DE TEMP	FLIEHGEWICHT SCHAUFELZAHNTASCHE OELFILTER UND WAERMETAUSCHER	CONTRAPESO ASIEN TO DIENTE CUCHARA FILTROS DE ACEITE Y CAMBIADORES DE CALOR
68G 68S 68D 68A 69F 69G 69I 69I	GIUNTO ELASTICO SEDE DENTE RIPPER DISPOS ELIMINAZIONE UMIDITA INIEITTORE ALCOOL FINESTRA GIUNTO FLESSIBILE INTERRUTTORE ELETTROMAGNETICO	FLEXIBLE JOINT RIPPER SHANK SEAT MOISTURE EJECTOR ALCOHOL INJECTOR WINDOW DEFLECTING JOINT ELECTROMAGNETIC SWITCH	JOINT ELASTIQUE EMPLACEMENT DENT SCARIFICATEUR DISP ELIMINATION D HUMIDITE INJECTEUR D ALCOOL BAIE JOINT ELASTIQUE INTERRUPTEUR ELEC- TROMAGNETIQUE	ELASTISCHE KUPPLUNG AUFREISSERZAHNTASCHE DEFROSTER ALKOHOLINJEKTOR FENSTER TRUCKENGELENK MAGNETSCHALTER	JUNTA ELASTICA ASIEN TO DIENTE RIPPER INVECTOR DE ALCHOL VENTANA JUNTA FLEXIBLE INTERRUPTOR ELEC- TROMAGNETICO
69S 70F 70G 70L 70R 70S 70T 70D 71A 71B 71B	SEDE FLANGIA GIUNTO SFERICO LONGHERINA RIPARO SEDE DELLA BATTERIA TEGOLO DISP SEGNALATORE RIBALTAMENTO ASSE BLOCCHETTI DI CHIUSURA	SEAT FLANGE BALL JOINT SIDE RAIL GUARD BATTERY SEAT PROTECTIVE PANEL TILTING SAFETY DEVICE AXLE LOCK CYLINDERS	EMPLACEMENT BRIDE JOINT A ROTULE LONGRINE PROTECTION SIEGE DE BATTERIE DESSUS DISP SIGNEUR BASCULAGE AXE BARILLETS DE SER- RURE	VENTILSITZ FLANSCH KUGELGELENK LAENGSSEHIENE SCHUTZ BATTERIESITZ SCHUTZ UEBERLASTWARNANLAGE ACHSE SCHLOSSZYLINDER	ASIEN TO BRIDA ARTICULACION VARILLA DEFENSA SOPORTE DE BATERIA TEJA
71F 71G 71G 71L 72D 72D 72F 72G 72I 73G 73G	FILTRO ARIA BAGNO OLIO GIUNTO BIPOLARE LONGHERONE DISPOSITIVO DI REGOLAZIONE FLESSIBILE GIUNTO IDRAULICO INTELAIATURA GIUNTO MULTIPOLARE	OIL BATH AIR CLEANER 2-POLE CONNECTOR SIDE MEMBER GOVERNOR REGULATING ASSY FLEXIBLE SHAFT FLUID DRIVE FRAME MULTIPOLE CONNECTOR	FILTRE A AIR A BAIN D HUILE JOINT A 2 POLES LONGERON DISPOSITIF DE REGLAGE TRANSMISSION FLEXIBLE COUPLEUR HYDR CHASSIS JOINT MULTIPOLAIRE	ØELBADLUFTFILTER 2-POL KUPPLUNGS- KOPF LAENGSTRÄGER REGELGRUPPE BIEGSAMEWELLE FLUESSIGK.KUPPLUNG RAHMEN MEHRPOL.KUPPLUNGS- KOPF	FILTRO DE AIRE EN BANO ACEITE EMPALME DE 2 POLOS LARGUERO DISPOSITIVO DE REGULACION ARBOL FLEXIBLE ACOPLAMIENTO HIDR. BASTIDOR EMPALME MULTIPOLAR

PART NUMBER	ITEM	KIT COMP. PART. N.	QTY	SGR.	TAV.	PAG.	GRID POS.	TRANS CODE	DESCRIPTION	DENOMINAZIONE
79055160										
	24	79030210	1	B2.01/1A	9	1	2-H4	123G	SEAL ASSY	GUARNIZIONE TENUTA FRONTALE
	17	79030211	1	B2.01/1A	2	1	1-T10	123G	SEAL ASSY	GUARNIZIONE TENUTA FRONTALE
	19	79030215	1	B2.01/1A	2	1	1-T10	158G	O-RING	GUARNIZIONE O-R
	21	79030217	1	B2.01/1A	2	1	1-T10	158G	O-RING	GUARNIZIONE O-R
	26	79030266	1	B2.01/1A	2	2	1-T11	123G	SEAL ASSY	GUARNIZIONE TENUTA FRONTALE
	7	79030268	2	B2.01/1A	3	1	1-T12	123G	SEAL ASSY	GUARNIZIONE TENUTA FRONTALE
	9	79030270	1	B2.01/1A	3	1	1-T12	158G	O-RING	GUARNIZIONE O-R
	37	79031003	1	B2.01/1A	1	2	1-T9	158G	O-RING	GUARNIZIONE O-R
	23	79086375	1	B2.01/1A	1	1	1-T8	122G	SEAL	GUARNIZIONE
79055596										
	1	4601827	3	A2.54	1	1	1-O15	123G	SEAL ASSY	GUARNIZIONE TENUTA FRONTALE
	2	4601981	6	A2.54	1	1	1-O15	123G	SEAL ASSY	GUARNIZIONE TENUTA FRONTALE
	1	4632108	1	A2.22	1	1	1-L8	123G	SEAL ASSY	GUARNIZIONE TENUTA FRONTALE
	6	4728639	1	A4.02	1	1	1-O2	133R	SEAL	ROSETTA DI TENUTA
	15	14462881	1	A4.02	2	2	1-P4	158G	O-RING	GUARNIZIONE O-R
	19	38824001	2	A4.02	1	2	1-P2	123G	SEAL ASSY	GUARNIZIONE TENUTA FRONTALE
	14	79032209	1	A2.56	1	1	1-O13	123G	SEAL ASSY	GUARNIZIONE TENUTA FRONTALE
79062511										
	1	4031577	1	A1.02	2A	1	1-H12	123G	SEAL ASSY	GUARNIZIONE TENUTA FRONTALE
	1	4600893	1	A1.25	1	1	1-I3	123G	SEAL ASSY	GUARNIZIONE TENUTA FRONTALE
	1	4605564	2	A1.02	1	1	1-H9	123G	SEAL ASSY	GUARNIZIONE TENUTA FRONTALE
	2	4607590	1	A1.02	2A	1	1-H12	123G	SEAL ASSY	GUARNIZIONE TENUTA FRONTALE
	4	4653283	1	A1.02	1	1	1-H9	123G	SEAL ASSY	GUARNIZIONE TENUTA FRONTALE
	3	4781578	1	A1.02	2A	1	1-H12	123G	SEAL ASSY	GUARNIZIONE TENUTA FRONTALE
	4	4781579	1	A1.02	2A	1	1-H12	123G	SEAL ASSY	GUARNIZIONE TENUTA FRONTALE
	5	4782785	1	A1.02	1	1	1-H9	123G	SEAL ASSY	GUARNIZIONE TENUTA FRONTALE
	6	4782786	1	A1.02	1	1	1-H9	123G	SEAL ASSY	GUARNIZIONE TENUTA FRONTALE
	23	14463880	1	A1.02	1	2	1-H10	158G	O-RING	GUARNIZIONE O-R

FIATALLIS FD7

NTR. 205

30.09.91 - 60401081.06

PART NUMBER	ITEM	KIT COMP. PART. N.	QTY	SGR.	TAV.	PAG.	GRID POS.	TRANS CODE	DESCRIPTION	DENOMINAZIONE
79062511	24	14483080	1	A1.02	1	2	1-H10	158G	O-RING	GUARNIZIONE O-R
79062512	5	4754069	1	A1.01/ A	1	1	1-H6	123G	SEAL ASSY	GUARNIZIONE TENUTA FRONTALE
	5	4845138	1	A1.01/ A	2	1	1-H7	123G	SEAL ASSY	GUARNIZIONE TENUTA FRONTALE
79066594	20	79066594	1	D2.23	3	2	2-M14	2K	KIT	KIT
79067856	1	79067856	1	A2.35/1A	1	1	1-N14	2K	KIT	KIT
79069735	1	79069735	1	A2.35/2A	1	1	1-N16	2K	KIT	KIT
79070385	27	79070385	1	F3.03/ A	1	1	2-T3	2K	KIT	KIT
79071307	7	79065569	1	E3.32/ 4	1	1	2-S17	122G	SEAL	GUARNIZIONE
	10	79065570	1	E3.32/ 4	1	1	2-S17	45A	RING	ANELLO
	2	79065571	1	E3.32/ 4	1	1	2-S17	42A	MUDSCRAPER RING	ANELLO RASCHIAFANGO
79071319	4	79065560	1	E3.32/ 5	1	1	2-S15	120G	GASKET	GUARNIZIONE PIANA
	3	79065561	1	E3.32/ 5	1	1	2-S15	45A	RING	ANELLO
	1	79065562	1	E3.32/ 5	1	1	2-S15	122G	SEAL	GUARNIZIONE
79071319	5	79065560	1	E3.32/ 6	1	1	2-S14	120G	GASKET	GUARNIZIONE PIANA

9/15

G2

FIATALLIS FD7

NTR. 205

30.09.91 - 60401081.06

PART NUMBER	ITEM	KIT COMP. PART. N.	QTY	SGR.	TAV.	PAG.	GRID POS.	TRANS CODE	DESCRIPTION	DENOMINAZIONE
79071319	4	79065561	1	E3.32/ 6	1	1	2-S14	45A	RING	ANELLO
	2	79065562	1	E3.32/ 6	1	1	2-S14	123G	SEAL ASSY	GUARNIZIONE TENUTA FRONTALE
79071400	6	79071400	1	A2.27/ A	1	1	1-M3	2K	KIT	KIT
79071400	6	79071400	1	A2.27/ A	2	1	1-M2	2K	KIT	KIT
79071400	6	79071400	1	A2.27/ A	3	1	1-N2	2K	KIT	KIT
79071400	6	79071400	1	A2.27/ A	4	1	1-N3	2K	KIT	KIT
79071471	6	79065557	1	E3.32	1	1	2-R13	122G	SEAL	GUARNIZIONE
	4	79065558	1	E3.32	1	1	2-R13	45A	RING	ANELLO
	2	79065559	1	E3.32	1	1	2-R13	122G	SEAL	GUARNIZIONE
79074707	13	79074707	1	F3.03/ 1	1	1	2-T4	2K	KIT	KIT
79074707	13	79074707	1	F3.03/ 1A	1	1	2-T5	2K	KIT	KIT
79081045	5	79081045	1	F2.05/ A	1	1	2-S6	2K	KIT	KIT
79081046	6	79081046	1	F2.05/ A	1	1	2-S6	2K	KIT	KIT

9/16

G3

7A

FIATALLIS FD7

NTR. 205

30.09.91 - 60401081.06

PART NUMBER	ITEM	KIT COMP. PART. N.	QTY	SGR.	TAV.	PAG.	GRID POS.	TRANS COD/L	DESCRIPTION	DENOMINAZIONE
79086428										
	1	4599809	1	A4.02	1	1	1-O2	123G	SEAL ASSY	GUARNIZIONE TENUTA FRONTALE
	1	4632108	1	A2.22	1	1	1-L8	123G	SEAL ASSY	GUARNIZIONE TENUTA FRONTALE
	6	4770265	1	A4.02	1	1	1-O2	122G	SEAL	GUARNIZIONE
	1	4776544	3	A2.54	1	1	1-O15	123G	SEAL ASSY	GUARNIZIONE TENUTA FRONTALE
	2	4813566	6	A2.54	1	1	1-O15	123G	SEAL ASSY	GUARNIZIONE TENUTA FRONTALE
	10	10260160	2	A2.54	1	1	1-O15	133R	SEAL	ROSETTA DI TENUTA
	15	14463281	1	A4.02	2	2	1-P4	158G	O-RING	GUARNIZIONE O-R
	14	79032209	1	A2.56	1	1	1-O13	123G	SEAL ASSY	GUARNIZIONE TENUTA FRONTALE

9/17

G4

MODIFICATION - MODIFICA		Summary of involved subgroups and directions for replacement. Sottogruppi interessati e norme di ricambio.
C 1117 → Tel. n. 250224	D 1117 Tel. n. 250225 →	F4.31 79031355 = 79048326
C 1158 → Tel. n. 250118	D 1158 Tel. n. 250119 →	B2.06 79024729 = 79043444
C 1159 → Tel. n. 250235	D 1159 Tel. n. 250236 →	E3.02 - E3.31 - E3.34 E3.02: 79027108 = 79041699 + 79043703. E3.31: 8296629 = 79040776 + 14489121. 8295969 = 79040777 + 11087976. 8295966 = 79040784 79027080 = 79040769
C 1160 → Tel. n. 250239	D 1160 Tel. n. 250240 →	B3.16 79028402 = 70929049
	D 1161 Tel. n. 250103 →	L3.08
C 1162 → Tel. n. 250235	D 1162 Tel. n. 250236 →	E3.31 79041702 = 79045694 79041703 = 79045695
C 1163 → Tel. n. 250103	D 1163 Tel. n. 250103 →	L3.04 79016720 = 79048203 79033501 = 79048258 79033502 = 79048259

FIATALLIS FD7

MODIFICATION — MODIFICA		Summary of involved subgroups and directions for replacement. Sottogruppi interessati e norme di ricambio.
C 1164 → Tel. n. 250102	D 1164 Tel. n. 250103 →	E3.02 — F4.01
C 1165 → Tel. n. 250102	D 1165 Tel. n. 250103 →	B2.06
C 1166 → Tel. n. 250102	D 1166 Tel. n. 250103 →	A1.08
C 1167 → Tel. n. 250102	D 1167 Tel. n. 250103 →	E3.02
C 1168 → Tel. n. 250190	D 1168 Tel. n. 250191 →	B2.38 4977072 = 76006064
C 1169 → Tel. n. 250102	D 1169 Tel. n. 250103 →	B2.01 70927696 = 70935974 73118075 = 73132674 73118056 = 73132932 71004777 = 73132784
C 1170 → Tel. n. 250102	D 1170 Tel. n. 250103 →	D3.34 587271 = 79043802 79019557 = 79043805
C 1171 → Tel. n. 250102	D 1171 Tel. n. 250103 →	B2.01 70910287 = 8273916 74055100 = 70905360
C 1409 → Tel. n. 250903	D 1409 Tel. n. 250904 →	D2.23 — D2.27 D2.23: 581610 = 79062723

FIATALLIS FD7

MODIFICATION -- MODIFICA		Summary of involved subgroups and directions for replacement. Sottogruppi interessati e norme di ricambio.
C1506 → tel. n. 250200	D1506 tel. n. 250201 →	B2.06
	D1507 tel. n. 250419 →	A2.22
C1508 → tel. n. 250550	D1508 tel. n. 250551 →	D3.40 - D3.40/1 79012420, 79012421 = 76008353 + 76008354
C1509 → tel. n. 250459	D1509 tel. n. 250460 →	L3.04
C1510 → tel. n. 250904	D1510 tel. n. 250905 →	A2.21 - A2.22 - A3.01 - A4.01 - B2.00 - B2.01 - B2.01/A - B2.01/B - B2.01/1 - B2.01/1A - B2.06 - B2.33 - B2.33/A - B2.34 - B2.34/A - D2.23 - D2.27 - D2.27/A - F2.01 - F4.01 - F5.10 - B2.06: 79038143 = 79049511 + 79022154 + 79049513 D2.23: 79062723 = 5120481 + 79052017 + 10903631 (2) + 10571579 (2) + 16044031 (2) + 14496501 (2) 79020577 = 79052017 + 70921963 (2) F4.01: 79043371 = 76010585 79042823 = 76010396
C1519 1 - 1983	D1519 1 - 1983	B4.08 - D2.22 - D2.23 - D2.24 B4.08: 79023988 = D1519 D2.24: 79036601 = 79044947

FIATALLIS FD7

MODIFICATION – MODIFICA		Summary of involved subgroups and directions for replacement. Sottogruppi interessati e norme di ricambio.
C1520 → tel. n. 250480	D1520 tel. n. 250481 →	B4.08 – D2.23 B4.08: 79044942 = 79050503 D2.23: 79044954, 79017863, 79034391 - 79052025 + 79043436 + 79013422 + 79043442
C1522 → tel. n. 250659	D1522 tel. n. 250660 →	A1.08 – A1.08/A
C1523 → tel. n. 250395	D1523 tel. n. 250396 →	F4.01 79039833 = 79048771, 79050321
C1524 → tel. n. 250396	D1524 tel. n. 250397 →	F5.01 4239805 = 79056873
C1525 → tel. n. 250648	D1525 tel. n. 250649 →	F5.10 – L1.01 F5.10: 79042633 = 79054141 L1.01: 79042406 = 79054632 79042186 = 79054634
C1532 → tel. n. 250685	D1532 tel. n. 250686 →	B2.00 – B2.01 – B2.01/A
C1558 → tel. n. 250102	D1558 tel. n. 250103 →	B4.04 79013340 = 79061879

MODIFICATION -- MODIFICA		Summary of involved subgroups and directions for replacement. Sottogruppi interessati e norme di ricambio.
C1572 → tel. n. 250904	D1572 tel. n. 250905 →	A0.00 – A1.01 – A1.01/A – A1.02 – A1.03 – A1.03/A – A1.04 – A1.05 – A1.05/A – A1.06 – A1.06/A – A1.07 – A1.07/A – A1.15 – A1.15/A – A1.16 – A1.16/A – A1.25 – A2.24 – A2.24/A – A2.25 – A2.25/A – A2.26 – A2.26/A – A2.27 – A2.27/A – A2.28 – A2.33 – A2.35 – A2.35/A – A2.35/1 – A2.35/1A – A2.35/2 – A2.35/2A – A2.35/3 – A2.37 – A2.54 – A3.01 – A3.02 – A4.02 – A4.03 – A4.04 – A4.09 – B2.18 – B2.21 – E2.15 – F2.01 – F2.05 – F2.05/A – F3.01 – F3.03 – F3.03/A
C1574 → tel. n. 250838	D1574 tel. n. 250839 →	B2.07 79005610 = 79043491
C1575 → tel. n. 250871	D1575 tel. n. 250872 →	A1.08/A 79048629 = 79077026 + 76012442
C1576 → tel. n. 250884	D1576 tel. n. 250885 →	F3.01 – L1.30 – L1.30/A
C1578 → tel. n. 250921	D1578 tel. n. 250922 →	F5.01/1 – F5.01/1A
C1579 → tel. n. 250933	D1579 tel. n. 250934 →	B4.12 – D3.33 D3.33: 79024821 = 79058653 + 79058654
C1580 → tel. n. 250977	D1580 tel. n. 250978 →	F4.01 79033172 = 79076344
C1581 → tel. n. 251034	D1581 tel. n. 251035 →	F4.01 79048326 = 79073031

FIATALLIS FD 7

MODIFICATION -- MODIFICA		Summary of involved subgroups and directions for replacement. Sottogruppi interessati e norme di ricambio.
C1582 → tel. n. 251069	D1582 tel. n. 251070 →	B4.04 – B4.04/A
C1585 → tel. n. 251065	D1585 tel. n. 251066 →	B2.06 79028382 = 79028146
C1586 → tel. n. 251077	D1586 tel. n. 251078 →	A4.09 79035174 = 76013040
C1588 → tel. n. 251112	D1588 tel. n. 251113 →	A1.08/A 79050355 = 76012442
C1611 → tel. n. 250418	D1611 tel. n. 250419 →	A3.01 79037665, 79037668 = 79050381 + 79050442
C1612 → tel. n. 250441	D1612 tel. n. 250442 →	E3.02 – E3.02/5 – E3.02/7 – E3.02/8 – E3.02/9 – E3.32 – E3.32/2 – E3.32/4 – E3.32/5 – E3.02: 79039427 = 79047903 E3.02/5: 79039486 = 79047905 E3.02/7: 79039545 = 79047906 E3.02/8: 79039467 = 79047904 E3.02/9: 79039486 = 79047905 E3.32: 79038729 = 79047725 E3.32/2: 79038227 = 79047724 E3.32/4: 79038367 = 79047726 E3.32/5: 79038227 = 79047724

MODIFICATION -- MODIFICA		Summary of involved subgroups and directions for replacement. Sottogruppi interessati e norme di ricambio.
C1613 → tel. n. 250602	D1613 tel. n. 250603 →	L1.01 4952067 = 79014117
C1614 → tel. n. 250689	D1614 tel. n. 250690 →	A2.01 4982644 = 79043879
C1615 → tel. n. 250686	D1615 tel. n. 250687 →	E3.10/7 8288668 = D1615
C1616 → tel. n. 250851	D1616 tel. n. 250852 →	E3.02 - E3.02/8 - E3.02/9 - E3.02/10
C1617 → tel. n. 251010	D1617 tel. n. 251011 →	A1.08/A 79052451 = 79050429
C1618 → tel. n. 251066	D1618 tel. n. 251067 →	E3.10/7 79043346 = 79076598
C1619 → tel. n. 251294	D1619 tel. n. 251295	E3.02/10 - E3.32/6 E3.02/10: 79047905 = 76014155
C1620 → tel. n.	D1620 tel. n. →	E3.10/7 - E3.13/3 E3.10/7: 8297617 = D1620 E3.13/3: 8297721 = D1620
C 2836 → tel. n. 251415	D2836 tel. n. 251416 →	B4.08 - B4.11

47C

FIATALLIS FD7

N.T.R. 191 - 28.02.1990 - 60401081.04

MODIFICATION - MODIFICA		Summary of involved subgroups and directions for replacement. Sottogruppi interessati e norme di ricambio.
C 2837 → Tel.n. 251332	D 2837 Tel.n. 251333 →	F4.01 - F4.01/A - F4.01/1 - F4.01/1A - F4.01/2 - F4.01/2A - F4.05 - F4.05/A
C 2845 I-1987	D 2845 I-1987	F4.01
C 2869 → Tel.n. 251325	D 2869 Tel.n. 251326 →	D3.33 - D3.40 - D3.40/A - D3.40/1 79025810 = 79086892 + 79087039
C 2872 → Tel.n. 251766	D 2872 Tel.n. 251767 →	E3.02/6 - E3.02/9 - E3.02/10 - E3.32/3 79029964 = 79099278 + 79099277 + + 14466580 + 79099276
C 2873 → Tel.n. 250911	D 2873 Tel.n. 250912 →	F4.01
C 2874 → Cab.n. 7G01330	D 2874 Cab.n. 7G01331 →	L3.08
C 2875 → Tel.n. 251273	D 2875 Tel.n. 251274 →	A2.01
C 2905 → Tel.n. 251325	D 2905 Tel.n. 251326 →	F4.01
C 2906 → Tel.n. 251340	D 2906 Tel.n. 251341 →	A2.22 - A4.02 - D2.23 - E3.02
C 2907 → Tel.n. 251423	D 2907 Tel.n. 251424 →	A2.01 - E3.28
C 2908 → Tel.n. 251353	D 2908 Tel.n. 251354 →	L3.04

MODIFICATION - MODIFICA		Summary of involved subgroups and directions for replacement. Sottogruppi interessati e norme di ricambio.
C 2909 → Tel.n. 251324	D 2909 Tel.n. 251325 →	A2.22
C 2910 → Tel.n. 251380	D 2910 Tel.n. 251381 →	B2.10
C 2911 → Tel.n. 250904	D 2911 Tel.n. 250905 →	B2.01 - B2.01/A - B2.01/B B2.01/1 - B2.01/1A
C 2912 → Tel.n. 251553	D 2912 Tel.n. 251554 →	D2.22
C 2913 → Tel.n. 251589	D 2913 Tel.n. 251590 →	E3.10 - E3.10/1 - E3.10/7
C 2914 → Tel.n. 251474	D 2914 Tel.n. 251475 →	E3.02/10 - E3.32/6
C 2915 → Tel.n. 251704	D 2915 Tel.n. 251705 →	E3.28
C 2916 → Tel.n. 251590	D 2916 Tel.n. 251591 →	E3.32 - E3.32/4 - E3.32/5 - E3.32/6
C 2917 → Tel.n. 251529	D 2917 Tel.n. 251530 →	A2.01
C 2935 → Tel.n. 250904	D 2935 Tel.n. 250905 →	A2.35/A
C 2936 → Tel.n.	D 2936 Tel.n. →	E3.10/8 - E3.10/9 - E3.13/4 - E3.13/5
C 2937 → Tel.n. 251764	D 2937 Tel.n. 251765 →	F4.01
C 2938 → Tel.n. 251780	D 2938 Tel.n. 251781 →	F4.01

MODIFICATION - MODIFICA			Summary of involved subgroups and directions for replacement. Sottogruppi interessati e norme di ricambio.
C 2939 → Tel.n. 251782	D 2939 Tel.n. 251783	→	C1.01 - D2.20 - D2.23 - D2.29
C 2946 → Cab.n. 8C1466	D 2946 Cab.n. 8C1457	→	F4.01/2A
C 2947 → Tel.n. 251570	D 2947 Tel.n. 251571	→	L3.10
C.2948 → Tel.n. 251579	D 2948 Tel.n. 251580	→	E3.02 - E3.02/7 - E3.02/8 - E3.02/10 - E3.32 - E3.32/4 - E3.32/5 - E3.32/6
C 2949 → Tel.n. 251539	D 2949 Tel.n. 251540	→	L1.30/1
C 2950 → Tel.n. 250904	D 2950 Tel.n. 250905	→	B2.01/B - B2.01/1A
C 2951 → IX-1989	D 2951 IX-1989		B2.01/B - B2.01/1A
C 2952 → Tel.n. 250904	D 2952 Tel.n. 250905	→	A2.27/A
C 2953 → Tel.n. 251753	D 2953 Tel.n. 251754	→	F3.01
C 2954 → Tel.n. 251741	D 2954 Tel.n. 251742	→	B2.06 - F4.01
C 2955 → Cab.n. 8B0180	D 2955 Cab.n. 8B0181	→	F4.01/2A
C 2956 → Cab.n. 8B0180	D 2956 Cab.n. 8B0181	→	L1.04
C 2957 → Tel.n. 251767	D 2957 Tel.n. 251768	→	C1.35 - C1.35/A

MODIFICATION - MODIFICAZIONE		Summary of involved subgroups and directions for replacement. Sottogruppi interessati e norme di ricambio.
C 2958 → Mot.n. 329342	D 2958 Mot.n. 329343 →	A4.02 - A4.09
C 3212 VII-1990	D 3212 VII-1990	F4.01 - L1.30/1
C 3213 IV-1990	D 3213 IV-1990	B2.01 - B2.01/1
	D 3214 Tel.n. 251871 →	A4.09/1
C 3215 → Tel.n. 251750	D 3215 Tel.n. 251751 →	E3.28
C 3265 R	D 3265 R	L1.04
C 3266 R	D 3266 R	E3.32/3
C 3267 → Tel.n. 251815	D 3267 Tel.n. 251816 →	F4.01/A
C 3276 → Tel.n. 251858	D 3276 Tel.n. 251859 →	D2.22
C 3277 I-1990	D 3277 I-1990	A1.08/A
C 3279 → Tel.n. 251819	D 3279 Tel.n. 251820 → compresi i telai - including serial 251654-251656-251667-251669- 251674-251676-251683-251684	E3.10/7 - E3.13/3

MODIFICATION - MODIFICA		Summary of involved subgroups and directions for replacement. Sottogruppi interessati e norme di ricambio.
C 3280 R	D 3280 R	A2.35/A
C 3334 R	D 3334 R	A4.02 - A4.03 - A4.03/A
C 3335 R	D 3335 R	C1.01 - D2.22 - L3.10
C 3341 → Mot.n. 349217	D 2241 Mot.n. 349218 --	A1.02 - A1.16/A - A2.22 - A2.24 - A3.01 - A4.02 A4.04 - D2.23 - E2.15
C 3342 → Mot.n. 351017	D 3342 Mot.n. 351018 --	A4.02 - A4.03 - A4.03/A
C 3343 → Mot.n. 367082	D 3343 Mot.n. 367083 --	A4.09
C 3344 → Mot.n. 421911	D 3344 Mot.n. 421912 --	A4.02
C 3345 → Mot.n. 435435	D 3345 Mot.n. 435436 --	A1.01/A
C 3346 → Mot.n. 349616	D 3346 Mot.n. 349617 --	A1.07/A
C 3347 → Mot.n. 382705	D 3347 Mot.n. 282706 --	A1.02
C 3348 → Mot.n. 407953	D 3348 Mot.n. 407954 --	A4.02
C 3349 → Mot.n. 337543	D 3349 Mot.n. 337544 --	A1.07/A
C 3350 → Mot.n. 472391	D 3350 Mot.n. 472392 --	A4.02

MODIFICATION – MODIFICA		Summary of involved subgroups and directions for replacement. Sottogruppi interessati e norme di ricambio.
C 3446 R	D 3446 R	A4.01
C 3447 → Tel. n. 251910	D 3447 Tel. n. 251911 →	A0.00 - F3.01 - F3.03/A - F3.03/1 - F3.03/1A
C 3448 IV-1991	D 3448 IV-1991	L1.04

DESIGNAZIONE BASE	BASIC DESIGNATION	DESIGNATIONS-BASES	GRUNDRZEICHNUNGEN	DENOMINACIONES BASE
83I 83I	INTERRUTTORE AUTOMATICO	CIRCUIT BREAKER	INTERRUPTEUR AUTO- MATIQUE	INTERRUPTOR AUTO- Matico
83L	LAMA ANGOLABILE (HA)	ANGLE MOLDBOARD (HA)	LAME ANGLEDOZER (HA)	HOJA ANGULABLE (HA)
83S	SEDILE INTERMEDIO	INTERMEDIATE SEAT	SIEGE MEDIAN	BUTACA INTERMEDIA
833	COFANO FORATO	PERFORATED HOOD	CAPOT PERFORE	
835	RIPARO SUPPLEMENTARE CUFFIA	ADDITIONAL RADIATOR GUARD	PROTECTION SUPPL. RADIATEUR	
836	FIANCHETTI MOBILI MOTORE	HOOD SIDE PLATES	PANNEAUX LATERAUX MOTEUR	
837	RIPARI LATERALI MOTORE		PROTECTIONS LATERALES MOTEUR	
84C	CARTUCCIA FILTRANTE	FILTERING ELEMENT	ELEMENT FILTRANT	CARTUCHO DE FILTRO
84D	DISTRIBUTORE DUPLEX	DUPLEX DISTRIBUTOR	DISTRIBUT DUPLEX	DISTRIBUIDOR DUPLEX
84L	LAMA DIRITTA (HS)	STRAIGHT MOLDBOARD (HS)	LAME DOZER (HS)	HOJA RECTA (HS)
84P	PERNO DELLO STANTUFFO	PISTON PIN	AXE DE PISTON	BULON DE EMBOLO
84S	SEGNALATORE ACUSTICO	BUZZER	TEMPOIN SONORE	TIMBRE
842	PROTEZIONE ANTIVANDALO	VANDALISM PREVENTION		
843	COPERCHI CRUSCOTTO ANTIVANDALO	ANTI VANDALISM INSTRUM PANELS	CAPOT POUR PLANCHE DE BORD	PROTECCION DEL TABLERO
85A	ASSALE	AXLE	ESSIEU	EJE
85D	DISTRIBUTORE QUADRUPLEX	QUADRUPLEX DISTRIBUTOR	DISTRIBUTEUR QUADRUPLEX	DISTRIBUIDOR QUADRUPLEX
85D			FOURCHE	
85F	FORCELLA	YOKE	COUDE	HORQUILLA
85G	GOMITO	ELBOW	ISOLANT	CODO
85I	ISOLANTE	INSULATOR	ISOLANT	AISLADOR
85L	LAMA DIRITTA-LARGA (HS-L)	STRAIGHT-WIDE MOLDBOARD (HS-L)	LAME DOZER ELARGES (HS-L)	HOJA RECTA-ANCHA (HS-L)
85M	MOBILETTO	CABINET	ARMOIRE	ARMARIO
85R	RIPARTITORE	SPLITTER	REPARTITEUR	REPARTIDOR
85T	TELERUTTORE	RELAY	TELERUPTEUR	TELERRUPTOR
850	SEDILE RIBALTABILE	RECLINING SEAT	SIEGE BASCULABLE	ASIEN TO ABATIBLE
852	SEDILE C/SOSPENSIONE ELASTICA	SUSPENSION SEAT	SIEGE SUR SUSPENSIONS	ASIEN TO DE SUSPENSION ELASTICA
86D	DISTRIBUTORE A DOPPIO EFFETTO	DOUBLE ACTING CONTROL VALVE	DISTRIBUTEUR DOUBLE EFFET	DISTRIBUIDOR DE DOBLE EFECTO
86D			LAME SEMI U (HSU)	HOJA SEMI-U (HSU)
86L	LAMA SEMI-U (HSU)	SEMI-U MOLDBOARD (HSU)	SEGMENT	SEGMENTO
86S	SEGMENTO	SEGMENT	SEGMENT	SEGMENTO
861	PARAFANGHI ANTERIORI	FRONT FENDERS	AILES AVANT	GUARDABARROS ANTERIOR
863	PARAFANGHI POSTERIORI	REAR FENDERS	AILES ARRIERE	GUARDABARROS POSTERIOR
868	PARAFANGHI ALLUNGATI	FULL LENGTH FENDERS	AILES ALLONGEES	GUARDABARROS LARGOS
87C	CASSETTA ATTREZZI	TOOL BOX	COFFRE A OUTILS	CAJA HERRAMIENTAS
87D	DISTRIBUTORE E SEMPLICE EFFETTO	SINGLE ACTING CONTROL VALVE	DISTRIBUTEUR SIMPLE EFFET	DISTRIBUIDOR DE SIMPLE EFECTO
87D			AMPOULE	LAMPARITA
87L	LAMPADINA	BULB	TEMPOIN	TESTIGO
87S	SEGNALATORE	INDICATOR	TENDEUR DE COURROIE	SENSOR DE CORREA
87T	TENDICINGHIA	BELT STRETCHER		

DESIGNAZIONE BASE	BASIC DESIGNATION	DESIGNATIONS-BASES	GRUNDBEZEICHNUNGEN	DENOMINACIONES BASE	
870	PROTEZIONI FORESTALI	FORESTRY PROTECTIONS	PROTECTION DEFORSTAGE	SCHUTZ FUER FORSTEINSATZ	
871	SCHERMI POST E LAT ROPS	ROPS SIDE AND REAR SCREENS	GRILLES ARRIERE, LATERALES ROPS	ROPS-VERKLEIDUNG SEITLICH HINT	REJILLAS POSTERIOR LATERALROPS
872	PROTEZIONI INFERIORI (2 MEZZI)	BOTTOM GUARDS (2 PIECES)	PROTECTIONS INFERIEURS(2PIECES)	PANZERWANNE (2 TEILIG)	
873	SCHERMO POSTERIORE ROPS	ROPS REAR SCREEN	GRILLE ARRIERE ROPS	VERKLEIDUNG HINTER ROPS	
875	PROTEZIONI INFERIORI RINFORZ	EOTTOM GUARDS H.D	PROTECTION INFERIEURS RENFOR	PANZERWANNE VERSTAERKT	
879	SWEEPS PER ROPS	SWEEPS FOR ROPS	SWEEPS POUR ROPS	ABWEISER FUER ROPS	SWEEPS PARA ROPS
88A	ASTA DI REGOLAZIONE	ADJUSTING ROD	TIGE DE REGLAGE	EINSTELLSTANGE	VARILLA DE REGLAJE
88C	CASTELLO	MOUNTING FRAME	CHARPENTE	GERUEST	SOPORTE
88D	DIAGNOSTICA	DIAGNOSTIC SYSTEM	DIAGNOSE	DIAGNOSTIK	DIAGNOSTICA
88I	IDEOGRAMMI	SYMBOLS	IDEOGRAMMES	SYMBOLE	IDEOGRAMA
88S	SEMIACCOPIAMENTO	SEMI-COUPLING	DEMI-JOINT	KUPPLUNGSKOPF	SEMIACOPAMIENTO
88T	TENDINA	CURTAIN	RIDEAU	KUEHLERABDECKUNG	CORTINA
886	PERNO GANCIO TRAINO	DRAWBAR PIN	AXE CROCHET D'ATTELAGE	ANHAENGEBOELZEN	
88A	ASTA POSIZIONATORE	POSITIONING ROD	TIGE POSITIONNEUR	REGELSTANGE	VARILLA POSICIONADOR
89C	CASSONE SCRAPER	SCRAPER BOWL	BENNE DE DECAPEUSE	SCHUERFKUEBEL	CAJON
89D	DENTE BENNA	RUCKET TOOTH	DENT DE GODET	SCHAUFELZAHN	DIENTE DE CUCHARA
89G	GRAFFETTA	CLIP	AGRAFE	KLEMMSTUECK	SUJETADOR
89I	INIETTORE	INJECTOR	INJECTEUR	DUESE	INVECTOR
890	BARRA TRAINO OSCILLANTE	SWINGING DRAWBAR	BARRE OSCILLANTE D'ATTELAGE	ZUGPENDEL	
891	GANCIO TRAINO RINFORZATO	DRAWBAR H.D	CROCHET D'ATTELAGE RENFORCE	VERSTAERRTZUGHAKEN	
895	PREDISPOSIZ.ATTACCO SCRAPER	SCRAPER INSTALLATION PROVISION	PREDISP INSTALL SCRAPER	SCRAPERABAN ANHAENGE KUPPLUNG	
90A	ASTA	ROD	TIGE	STANGE	VARILLA
90B	BOCCHETTONI. INTRODUZIONE	FILLER PLUG	TUBE REMPLISSAGE	EINFUELLSTUTZEN	BOQUILLA
90C	CATADIOTTRI/	REFLECTOR	CATADIOPTRE	RUECKSTRAHLER	CATAFAROS
90D	DISCO MAGNETICO	MAGNETIC DISC	DISQUE MAGNETIQUE	MAGNETSCHEIBE	DISCO IMANADO
90S	GRANQ	DOWEL	GRAIN DE CENTRAGE	PASSTIFT	PITON
90I	INVOLUCRO	CANNING	INVOLUCRE	SCHUTZHUELLE	ENVOLTURA
90S	SEMIANELLO	HALF RING	DEMI-BAGUE	RINGHAELFTE	SEMIARO
91A	ASTA LIVELLO	DIPSTICK	JAUGE DE NIVEAU	MESS STAB	VARILLA DE NIVEL
91D	DISCO RUOTA	WHEEL DISC	DISQUE DE ROUE	RADNABE	DISCO RUEDA
92D	DAL MOTORE IDRAULICO...	FROM TO HYDRAULIC MOTOR...	A PARTIR DU MOTEUR HYDRAULIQUE	AB HYDRAULIKMOTOR	A PARTIR DEL MOTOR HIDRAULICO
92F	GRUPPO FRENANTE	BRAKE UNIT	GROUPE DE FREINAGE	BREMSE/RICHTUNG	DISPOSITIVO DE FRENO
92F					FRENO
92S	SEMIALBERO	HALF SHAFT	DEMI-ARBRE	HALBWELLE	SEMIARCOL
920	RIPPER (PD)	RIPPER (PD)	RIPPER (PD)	HECKAUFREISSER (PD)	RIPPER (PD)
921	RIPPER (PMD)	RIPPER (PMD)	RIPPER (PMD)	HECKAUFREISSER (PMD)	RIPPER (PMD)
93D	DAL RIDUTTORE...	FROM THE REDUCTION GEAR...	A PARTIR DU REDUCTEUR...	AB UNTERSETZUNGSGETRIEBE...	A PARTIR DEL REDUCTOR...
93F	FRENO	BRAKE	FREIN	BREMSE	FRENO
93T	TERGICRISTALLO	WINDSHIELD WIPER	ESSUIE-GLACE	SCHIEBENWISCHER	LIMPIA-PARABRISAS
933	RIPPER ROTATIVO		RIPPER ROTATIF	DREHAUFREISSER	

	DESIGNAZIONE BASE	BASIC DESIGNATION	DESIGNATIONS-BASES	GRUNDBEZEICHNUNGEN	DENOMINACIONES BASE
935	UTENSILE PER RIPPER	RIPPER SHANK	OUTIL POUR RIPPER	ZAHNHALTER	
937	UTENSILE (RIPPER PMD)	SHANK (RIPPER PMD)	OUTIL (RIPPER PMD)	ZAHNHALTER	
938	UTENSILE H.D (RIPPER PMD)	SHANK H.D (RIPPER PMD)	OUTIL (RIPPER PMD)	ZAHNHALTER (VA)	
94B	BOCCOLA SCANALATA	GROOVED BUSH	BAGUE CANNELEE	BUECHSE MIT NUTEN	CASQUILLO ACANALADO
94B					LADO
94C	CATENA ANTIDRUCCIOLEVOLE	ANTI-SKID CHAIN	CHAINE ANTI-DERAPANTE	GLEITSCHUTZKETTE	CADENA ANTIDESLIZANTE
94C					
94D	DENTE SCRAPER	SCRAPER TOOTH			
94S	SEMICOLLARE	HALF COLLAR	DEMI-COLLIER	SCELLENHAELFTE	SEMICOLLAR
94S					
94S	UTENSILI PER SCARIFICATORE		OUTIL POUR SCARIFICATEUR	ZAHNHALTER	
95B	BOCCOLA	BUSHING	DOUILLE	BUECHSE	BUJE
95C	CATENA	CHAIN	CHAINE	KETTE	CADENA
95F	FRIZIONE	CLUTCH	EMBRAYAGE	KUPPLUNG	EMBRAGUE
95S	SEMIBIELLA	HALF LINK	DEMI-BIELLE	SCHUBSTANGE	SEMIBIELLA
95T	TERMOMETRO	TEMPERATURE GAUGE	THERMOMETRE	THERMOMETER	TERMOMETRO
953	RIPPER (PL)	RIPPER (PL)	RIPPER (PL)	HECKAUFREISSER (PL)	RIPPER (PL)
96B	BOCCOLA DI GUIDA	GUIDE BUSHING	DOUILLE DE GUIDAGE	FUEHRUNGSBUECHSE	CASQUILLO GUIDA
96S	SEMIBOCCOLA	HALF BUSHING	DEMI-DOUILLE	BUECHSENHAELFTE	SEMIBUJE
96T	TERMOSTATO	THERMOSTAT	THERMOSTAT	THERMOSTAT	TERMOSTATO
960	RIPPER (PVD)	RIPPER (PVD)	RIPPEF (PVD)	HECKAUFREISSER (PVD)	RIPPER (PVD)
97C	CATENARIA	TRACK CHAIN	CHENILLES	KETTENZUG	CADENA DE ORUGA
97G	GRUPPO IDRAULICO	HYDRAULIC UNIT	GROPE HYDRAULIQUE	HYDRAULISCHE GRUPPE	GRUPO HIDRAULICO
97G					
97S	SEMIMORSETTO	HALF CONNECTOR	DEMI-COLLIER	KLEMMENHAELFTE	SEMIAGARRADERA
97T	TERMOCOPPIA	THERMOCOUPLE	THERMOCOUPLE	THERMOELEMENT	PAR TERMICO
98B	BOCCOLA ELASTICA	RESILIENT BUSH	BAGUE ELASTIQUE	ELASTISCHE BUECHSE	CASQUILLO ELASTICO
98G	GRUPPO MECCANICO	MECHANICAL UNIT	GROUPE MECANIQUE	MECHANISCHE GRUPPE	GRUPO MECANICO
98S	SEMISTAFFA	HALF BRACKET	DEMI-BRIDE	HALBSTUETZE	SEMIESTRIBO
988	TARGHE TUV TEDESCO	GERMAN TUV DECALS	PLAQUES TUV ALLEMAND	KLEBESCHILDER DEUTSCHER TUV	
99B	BOCCOLA FILETTATA	THREADED BUSH	BAGUE FILETEE	GEWINDEBUECHSE	TUERCA
99G	GRUPPO REGOLATORE	GOVERNOR UNIT	GROUP REGULATEUR	REGLERGRUPPE	GRUPO REGULADOR
9P2	POMPA A LEVE PER INGRASSAGGIO	GREASING PUMP	POMPE DE GRAISSAGE	FETTPRESSE	
993	POMPA TRAVASO COMBUST.	FUEL TRANSFER PUMP	POMPE TRANSVASEMENT COMBUSTIBLE	KRAFTSTOFFORDERPUMPE	BOMBA REPOSTADU COMBUSTIBILE
995	ACCESSORI MANUTENZIONE	TOOLS KIT	OUTILS	BORDWERKZEUG	HERRAMIENTAS
997	ELEMENTI PRIMA MANUTENZIONE	ELEMENT PACKAGE		INSPEK MATERIAL-ERSTE WARTUNG	
998	MARTINETTO IDRAULICO	HYDRAULIC JACK	CRIE HYDRAULIQUE	HYDRAULIKZYLINDER	
ALT	IN ALTERNATIVA	IN ALTERNATIVE	EN ALTERNATIVE	ALS ALTERNATIVE	ALTERNATIVO
ANT	ANTERIORE	FRONT	AVANT	VORN	ANTERIOR
CORR	CORRIGE	CORRECT	CORRIGEZ	RIGHTIG	LEASE
DS	DESTRO	RIGHT	DROIT	RECHTS	DERECHO

A

ENGINE • MOTORE • MOTEUR • МОТОР • MOTOR

H1

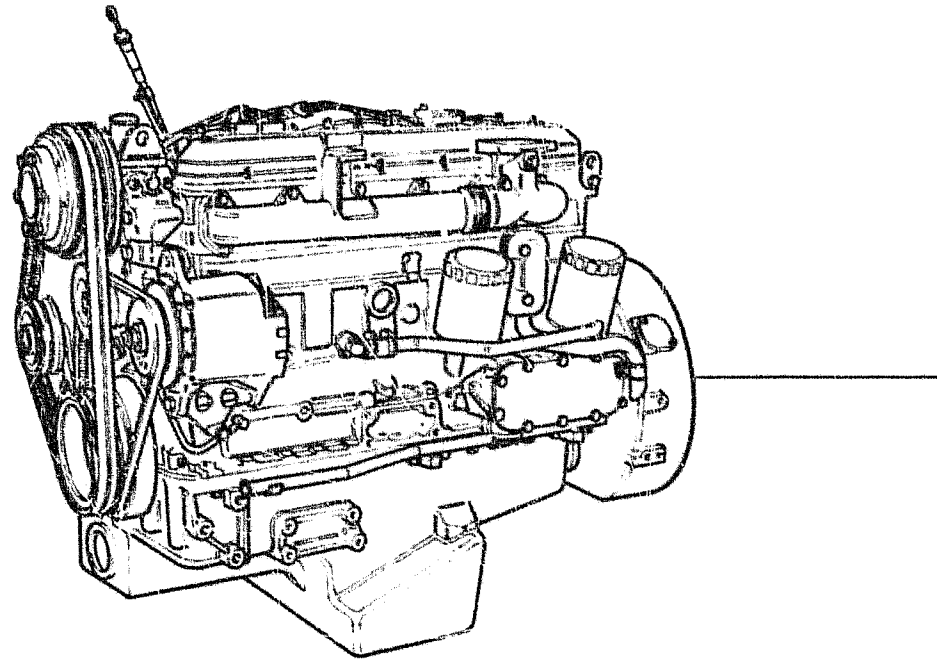

ITEM	PART NUMBER	QTY	TRANS CODE	DESCRIPTION	DESCRIZIONE
1	4731044	1	130M	ENGINE - ASSEMBLY C1572	MOTORE TERMICO - COMPLETO C1572
	4797619	1	130M	ENGINE - ASSEMBLY D1572	MOTORE TERMICO - COMPLETO D1572
		1	130M	ENGINE - ASSEMBLY C3447	MOTORE TERMICO - COMPLETO C3447
	98426137	1	130M	ENGINE - ASSEMBLY D3447	MOTORE TERMICO - COMPLETO D3447

ENGINE - MOTORE - MOTEUR - MOTOR - MOTOR

A0.00

N.T.R. 205 - 30.09.1991
604.01.081.06

H2

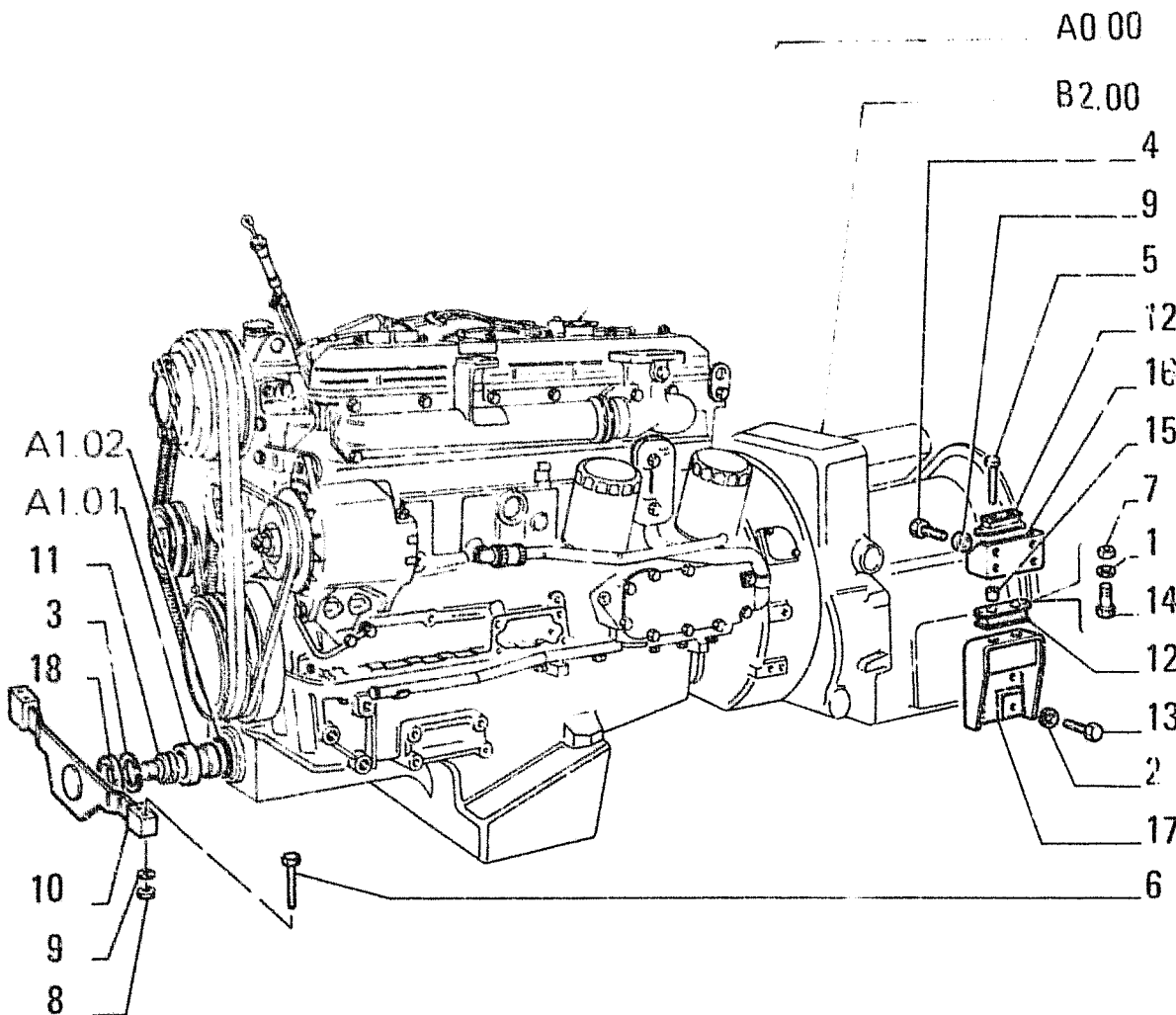

ITEM	PART NUMBER	QTY	TRANS CODE	DESCRIPTION	DESCRIZIONE
1	10516671	4	132R	LOCKWASHER 8,1x2,2	ROSETTA DI SICUREZZA 8 1x2,2
2	10517471	8	132R	LOCKWASHER 20,2x4 5	ROSETTA DI SICUREZZA 20,2x4,5
3	11060676	1	51A	LOCKRING 59,2x2	ANELLO DI SICUREZZA 59,2x2
4	14274631	8	40V	SCREW 12x1,25x35	VITE 12x1,25x35
5	15541331	4	40V	SCREW 12x1,25x75	VITE 12x1,25x75
6	15541931	4	40V	SCREW 12x1,25x130	VITE 12x1,25x130
7	16100821	4	10D	NUT 8x1,25x6 5	DADO 8x1,25x6,5
8	16101521	4	10D	NUT 12x1,25x10	DADO 12x1,25x10
9	79005242	16	131R	WASHER	ROSETTA
10	79013994	1	300S	SUPPORT - FRONT	SUPPORTO - ANTERIORE
11	79013999	1	165S	ARTICULATION	SNODO
12	79014002	4	61T	CUSHION PAD	TASSELLO ELASTICO
13	79014006	8	40V	SCREW	VITE
14	79022535	4	40V	SCREW	VITE
15	79022536	4	75D	SPACER	DISTANZIALI c
16	79022537	2	300S	SUPPORT - UPPER	SUPPORTO - SUPERIORE
17	79029881	1	300S	SUPPORT - LOWER RIGHT	SUPPORTO - INFERIORE DESTRO
	79029882	1	300S	SUPPORT - LOWER LEFT	SUPPORTO - INFERIORE SINISTRO
18	79041953	1	45A	RING	ANELLO

ENGINE SUSPENSIONS - SOSPENSIONI MOTORE - SUSPENSIONS DU MOTEUR - MOTORAUFHAENGUNG -
ANCLAJES MOTOR

C 1572 → Tel.n. 250904

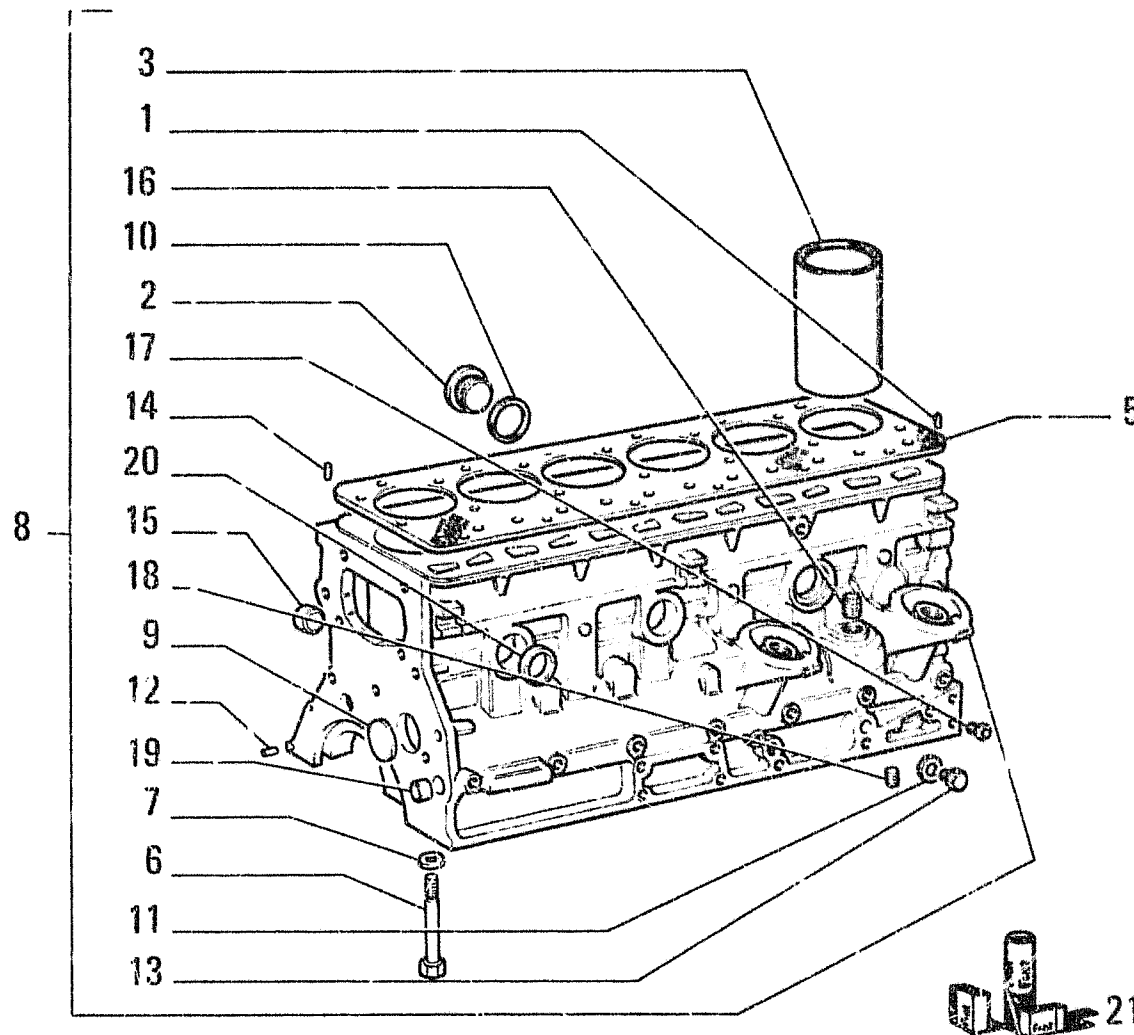

ITEM	PART NUMBER	QTY	TRANS CODE	DESCRIPTION	DESCRIZIONE
1	4599607	1	90G	DOWEL	GRANO
2	4665029	1	50T	PLUG	TAPPO
3	4679201	6	35C	CYLILINER	CAMICIA
	4679202	6	35C	CYLILINER + 0,2	CAMICIA + 0,2
5	4696355	1	173G	SEAL ASSY	GUARNIZIONE TENUTA FRONTALE
6	4710517	14	40V	SCREW	VITE
7	4710518	1	131R	WASHER	ROSETTA
8	4740097		20B	CRANKCASE - ASSEMBLY	BASAMENTO MOTORE - COMPLETO
9	10160701	1	50T	PLUG 60x2	TAPPO 60x2
10	10265460	1	133R	SEAL 42,3x49	ROSETTA DI TENUTA 42,3x49
11	10296160	2	133R	SEAL 12,2x18	ROSETTA DI TENUTA 12,2x18
12	10839610	2	90G	DOWEL 8x12	GRANO 8x12
13	11903211	1	50T	PLUG 12x1,25x8	TAPPO 12x1,25x8
14	14165470	1	200S	PIN 5,4x10	SPINA 5,4x10
15	14282770	6	50T	PLUG 36x9	TAPPO 36x9
16	14323811	1	50T	PLUG 20x1,5x21	TAPPO 20x1,5x21
17	14323911	6	50T	PLUG 10x1,25x14	TAPPO 10x1,25x14
18	14324211	2	50T	PLUG 14x1,5x20	TAPPO 14x1,5x20
19	14328501	1	50T	PLUG 16x5	TAPPO 16x5
20	14329901	3	50T	PLUG 40x12	TAPPO 40x12
21	79037380	1	1K	KIT SEE PAGE 9	KIT VED. PAG 9

CRANKCASE AND CYLINDER HEAD - BASAMENTO E TESTA CILINDRI - BATT ET CULASSE -
KURBELGEHAEUSE UND ZYLINDERKOPF- BLOQUE DE CILINDROS Y CULATA

A1.01

1

N.T.R. 191 - 20.02.1990

604.01.081.04

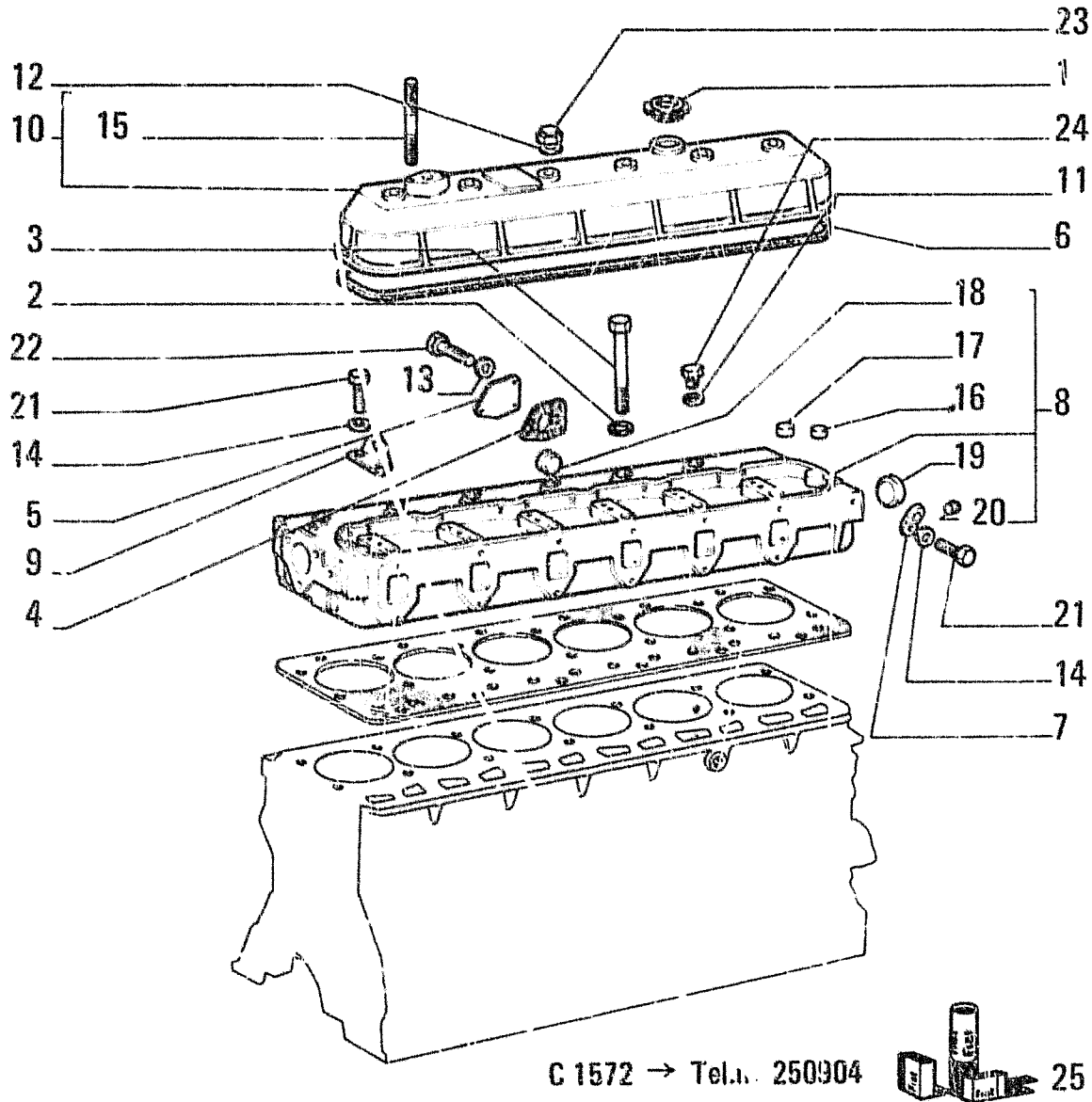

ITEM	PART NUMBER	QTY	TRANS CODE	DESCRIPTION	DESCRIZIONE
1	4232606	1	54T	FILLER CAP	TAPPO INTRODUZIONE
2	4585990	26	131R	WASHER	ROSETTA
3	4601061	26	40V	SCREW	VITE
4	4601390	1	123G	SEAL ASSY	GUARNIZIONE TENUTA FRONTALE
5	4609451	1	265C	COVER - SIDE	COPERCHIO - LATERALE
6	4628453	1	123G	SEAL ASSY	GUARNIZIONE TENUTA FRONTALE
7	4695922	1	120	EYELET - SIDE REAR LEFT	OCCHIELLO - LATERALE POSTERIORE SINISTRO
8	4739309	1	113T	CYLINDER HEAD - ASSEMBLY	TESTA CILINDRI - COMPLETO
9	4760284	1	120	EYELET - FRONT	OCCHIELLO - ANTERIORE
10	4763523	1	265C	COVER - ASSEMBLY	COPERCHIO - COMPLETO
11	10279560	1	133R	SEAL 22,2x28	ROSETTA DI TENUTA 22,2x28
12	10519660	6	131R	WASHER 8,45x17	ROSETTA 8,45x17
13	11198071	3	132R	LOCKWASHER 8,2x15	ROSETTA DI SICUREZZA 8,2x15
14	11198371	3	132R	LOCKWASHER 10,5x20	ROSETTA DI SICUREZZA 10,5x20
15	13516721	2	210P	STUD 8x1,25x30	PRIGIONIERO 8x1,25x30
16	14282370	1	50T	PLUG 25x7	TAPPO 25x7
17	14282470	12	50T	PLUG 28x9	TAPPO 28x9
18	14282770	1	50T	PLUG 36x9	TAPPO 36x9
19	14282970	1	50T	PLUG 45x9	TAPPO 45x9
20	14323911	1	50T	PLUG 10x1,25x14	TAPPO 10x1,25x14
21	15970521	3	40V	SCREW 10x1,25x20	VITE 10x1,25x20
22	16043421	3	40V	SCREW 8x1,25x20	VITE 8x1,25x20
23	16104111	6	10D	NUT 8x1,25x10,6	DADO 8x1,25x10,6
24	79030099	1	20R	FITTING	RACCORDO
25	79037380	1	1K	KIT SEE PAGE 9	KIT VED. PAG.9

CRANKCASE AND CYLINDER HEAD - BASAMENTO E TESTA CILINDRI - BATT ET CULASSE -
KURBELGEHAEUSE UND ZYLINDERKOPF - BLOQUE DE CILINDROS Y CULATA

A1.01

2

N.T.R. 191 - 20.02.1990

604 01.081.04

H5

D 1572 Tel.n. 250905 --

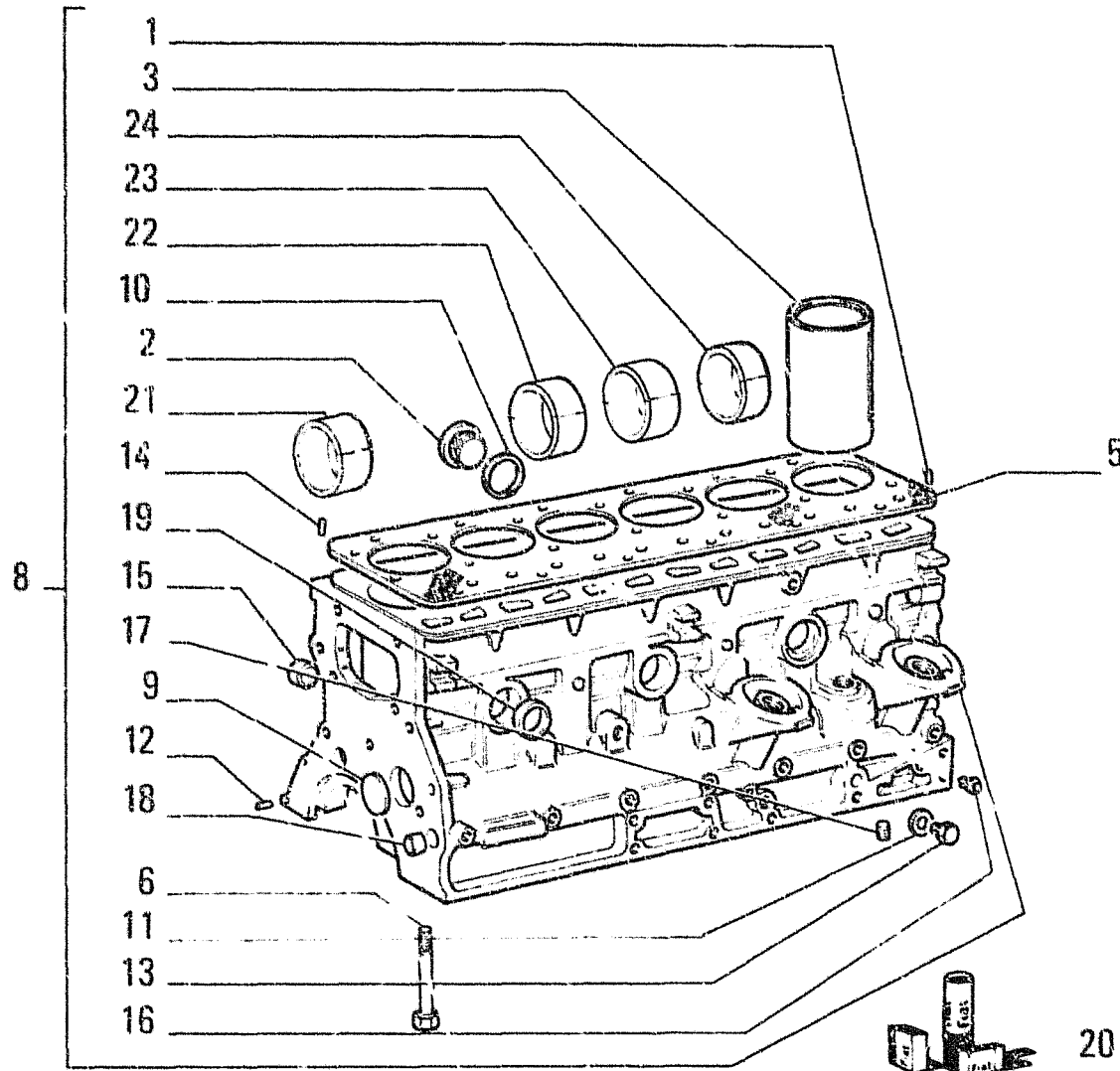

FIATALLIS FD7

A1.01/ A TAV. 1 PAG.1

I T E M	PART NUMBER	Q T Y	TRANS CODE	DESCRIP'ION	DESCRIZIONE
1	4599607	1	90G	DOWEL	GRANO
2	4665029	1	50T	PLUG	TAPPO
3	4770623	6	53C	TUBE +0,0	CANNA CILINDRO +0,0
	4770624	6	53C	TUBE +0,2	CANNA CILINDRO +0,2
5	4754069	1	123G	SEAL ASSY	GUARNIZIONE TENUTA FRONTALE
6	4792169	14	40V	SCREW	VITE
8	4809173	1	20B	CRANKCASE - ASSEMBLY	BASAMENTO MOTORE - COMPLETO
9	10160701	1	50T	PLUG 60x2	TAPPO 60x2
10	10265460	1	133R	SEAL 42,3x49	ROSETTA DI TENUTA 42,3x49
11	10298460	1	133R	SEAL 12,2x18	ROSETTA DI TENUTA 12,2x18
12	10839610	2	90G	DOWEL 8x12	GRANO 8x12
13	10300511	1	50T	PLUG 12x1,5x8	TAPPO 12x1,5x8
14	14165470	1	200S	PIN 5,4x10	SPINA 5,4x10
15	14282770	6	50T	PLUG 36x9	TAPPO 36x9
16	14323911	7	50T	PLUG 10x1,25x14	TAPPO 10x1,25x14
17	14324211	2	50T	PLUG 14x1,5x20	TAPPO 14x1,5x20
18	14328501	3	50T	PLUG 16x5	TAPPO 16x5
19	14329901	2	50T	PLUG 40x12	TAPPO 40x12
20	79062512	1	1K	KIT SEE PAGE 9	KIT VED PAG.9
21	4603448	1	95B	BUSHING - FRONT	BOCCOLA - ANTERIORE
22	4603449	1	95B	BUSHING - FRONT	BOCCOLA - ANTERIORE
23	4603450	1	95B	BUSHING - REAR	BOCCOLA - POSTERIORE
24	4603451	1	95B	BUSHING - REAR	BOCCOLA - POSTERIORE

CRANKCASE AND CYLINDER HEAD - BASAMENTO E TESTA CILINDRI - BATI ET CULASSE
 KURBELGEHAUSE UND ZYLINDERKOPF - BLOQUE DE CILINDROS Y CULATA

A1.01/A

1

N.T.R. 191 - 20.02.1990

804.01.081.04

H6

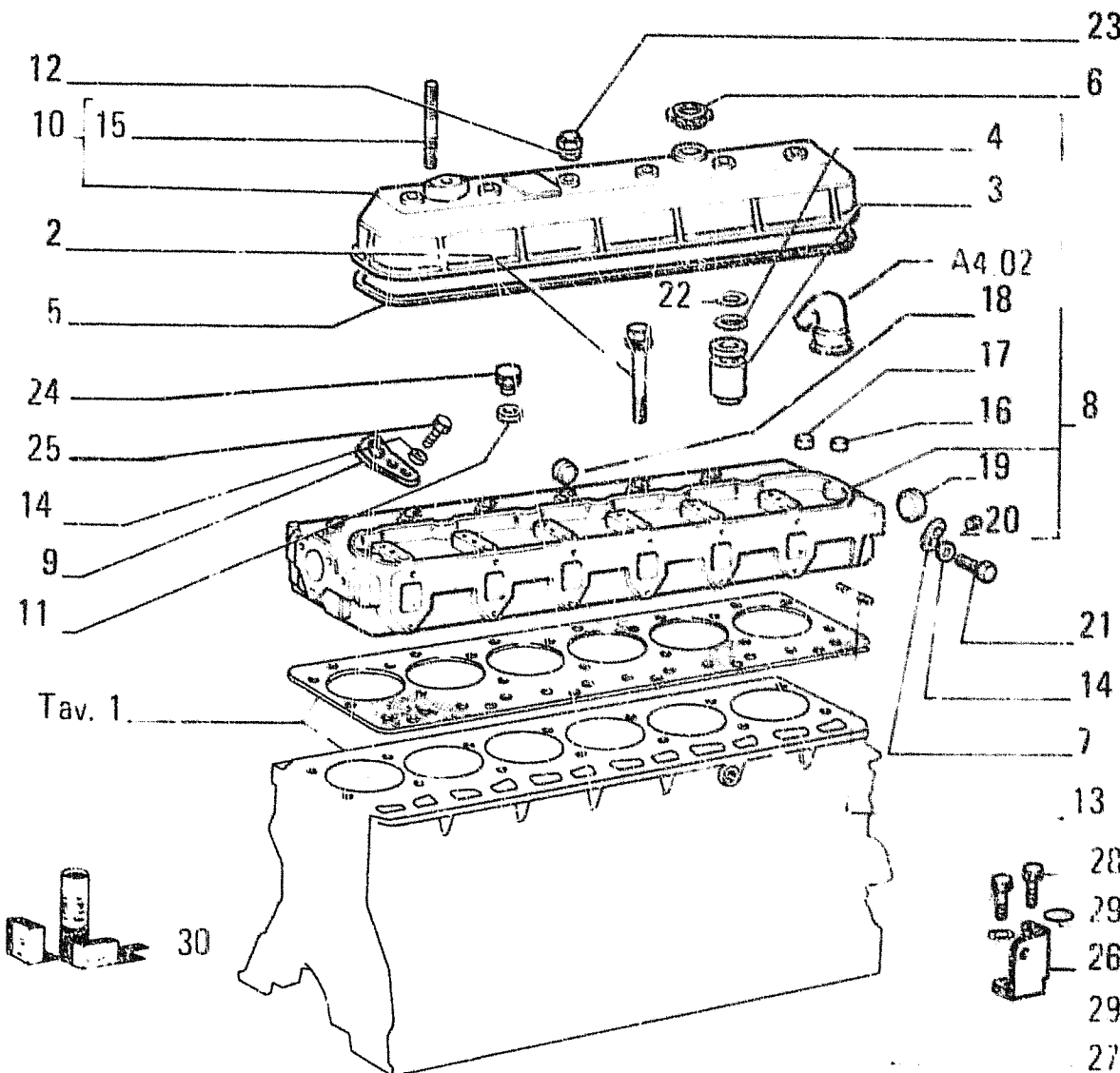

D 1572 Tel. n. 250905

ITEM	PART NUMBER	QTY	TRANS CODE	DESCRIPTION	DESCRIZIONE
2	4796457	26	40V SCREW		VITE
3	4770859	6	101A CASING		ASTUCCIO
4	14453981	12	158G O-RING 1,78x25,12		GUARNIZIONE O-R 1,78x25,12
5	4783241	1	122G SEAL C3345		GUARNIZIONE C3345
	4845138	1	123G SEAL ASSY D3345		GUARNIZIONE TENUTA FRONTALE D3345
6	4232606	1	50T PLUG		TAPPO
7	4695922	1	120 EYELET - REAR LEFT		OCCHIELLO - POSTERIORE SINISTRO
8	4782867	1	113T CYLINDER HEAD - ASSEMBLY		TESTA CILINDRI - COMPLETO
9	4760284	1	225S BRACKET - FRONT		STAFFA - ANTERIORE
10	4763523	1	265C COVER - ASSEMBLY		COPERCHIO - COMPLETO
11	10279560	1	133R SEAL 22,2x28		ROSETTA DI TENUTA 22,2x28
12	10519660	6	131R WASHER 8,45x17		ROSETTA 8,45x17
13	13517530	12	210P STUD 8x1,25x57		PRIGIONIERO 8x1,25x57
14	11190579	2	132R LOCKWASHER		ROSETTA DI SICUREZZA
15	13516721	2	210P STUD 8x1,25x30		PRIGIONIERO 8x1,25x30
16	14282170	1	50T PLUG 20x7		TAPPO 20x7
17	14282470	12	50T PLUG 28x9		TAPPO 28x9
18	14282770	1	50T PLUG 36x9		TAPPO 36x9
19	14282970	1	50T PLUG 45x9		TAPPO 45x9
20	14323911	1	50T PLUG 10x1,25x14		TAPPO 10x1,25x14
21	15970521	1	40V SCREW 10x1,25x20		VITE 10x1,25x20
22	14453589	6	133R SEAL		ROSETTA DI TENUTA
23	16104111	6	10D NUT 8x1,25x10,6		DADO 8x1,25x10,6
24	79030099	1	20R FITTING		RACCORDO
25	15970724	1	40V SCREW 10x1,25x25		VITE 10x1,25x25

CRANKCASE AND CYLINDER HEAD - BASAMENTO E TESTA CILINDRI -- BATI ET CULASSE --
 KURBELGEHAEUSE UND ZYLINDERKOPF -- BLOQUE DE CILINDROS Y CULATA

A101A

2

N.T.R. 200- 15.10.1990

604.01.081.05

H7

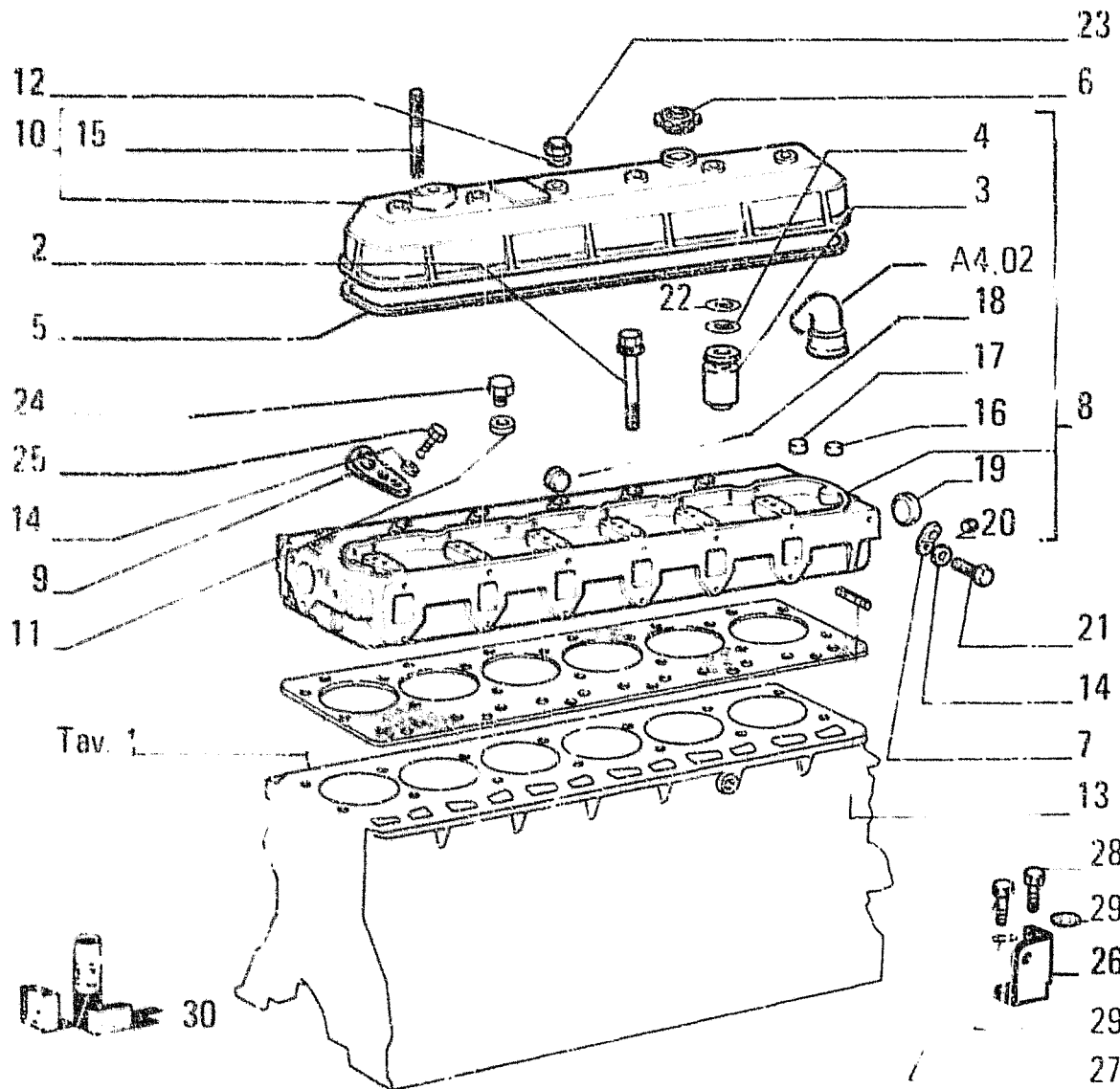

I T E M	PART NUMBER	Q T Y	TRANS CODE	DESCRIPTION	DESCRIZIONE
26	4695923	1	120	EYELET - REAR RIGHT	OCCHIELLO - POSTERIORE DESTRO
27	16044024	1	40V	SCREW 8x1,25x40	VITE 8x1,25x40
28	16043624	1	40V	SCREW 8x1,25x25	VITE 8x1,25x25
29	11193871	2	131R	WASHER 8,4x16	ROSETTA 8,4x16
30	79062512	1	1K	KIT SEE PAGE 9	KIT VED PAG 9

D 1572 Tel. n. 250905

CRANKCASE AND CYLINDER HEAD - BASAMENTO E TESTA CILINDRI - BATI ET CULASSE -
 KURBELGEHAEUSE UND ZYLINDERKOPF - BLOQUE DE CILINDROS Y CULATA

A101'A	2
N.T.R. 200 - 15.10.1990	
604.01.081.05	

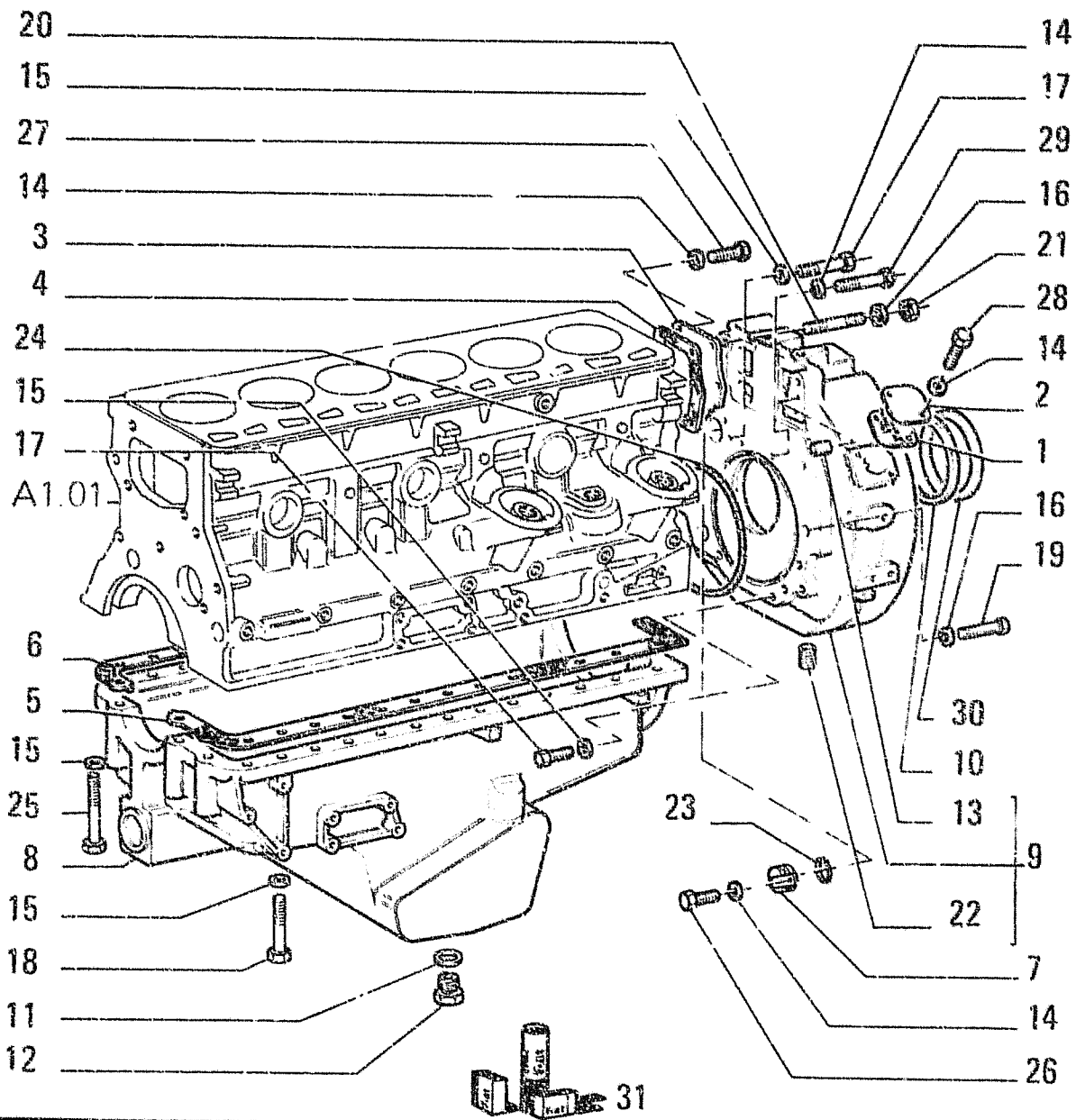

FIATALLIS FD7

ITEM	PART NUMBER	QTY	TRANS CODE	DESCRIPTION	DESCRIZIONE
1	4605564	2	123G	SEAL ASSY	GUARNIZIONE TENUTA FRONTALE
2	4607786	2	265C	COVER	COPERCHIO
3	4653282	1	265C	COVER - REAR	COPERCHIO - POSTERIORE
4	4653283	1	123G	SEAL ASSY	GUARNIZIONE TENUTA FRONTALE
5	4713071	1	123G	SEAL ASSY - LEFT C1572	GUARNIZIONE TENUTA FRONTALE - SINISTRO C1572
	4782785	1	123G	SEAL ASSY - LEFT D1572	GUARNIZIONE TENUTA FRONTALE - SINISTRO D1572
6	4713072	1	123G	SEAL ASSY - RIGHT C1572	GUARNIZIONE TENUTA FRONTALE - DESTRO C1572
	4782786	1	123G	SEAL ASSY - RIGHT D1572	GUARNIZIONE TENUTA FRONTALE - DESTRO D1572
7	4718740	1	50Y	PLUG	TAPPO
8	4730553	1	274C	OIL SUMP	COPPA OLIO
9	4745364	1	300S	SUPPORT - REAR ASSEMBLY C1572	SUPPORTO - POSTERIORE COMPLETO C1572
	4806131	1	300S	SUPPORT - REAR ASSEMBLY D1572	SUPPORTO - POSTERIORE COMPLETO D1572
10	4754028	1	75D	SPACER C1572	DISTANZIALE C1572
	4787154	1	75D	SPACER D1572	DISTANZIALE D1572
11	10263460	1	133R	SEAL 22,2x28	ROSETTA DI TENUTA 22,2x28
12	10305171	1	50T	PLUG 22x1,5x10	TAPPO 22x1,5x10
13	10839710	2	90G	DOWEL 10x15	GRANNO 10x15
14	11193871	13	131R	WASHER 8,4x16 D1572	ROSETTA 8,4x16 D1572
	11198071	13	132R	LOCKWASHER 8,2x15 C1572	ROSETTA DI SICUREZZA 8,2x15 C1572
15	11198371	39	132R	LOCKWASHER 10,5x20	ROSETTA DI SICUREZZA 10,5x20

OIL SUMP AND CRANKCASE COVERS - COPPA E COPERCHI BASAMENTO - CARTER DHUILE ET COUVERCLES DE BATI - OELWANNE UND DECKEL DES KURBELGEHAEUSES - CARTER DE ACEITE Y TAPAS DEL BLOQUE

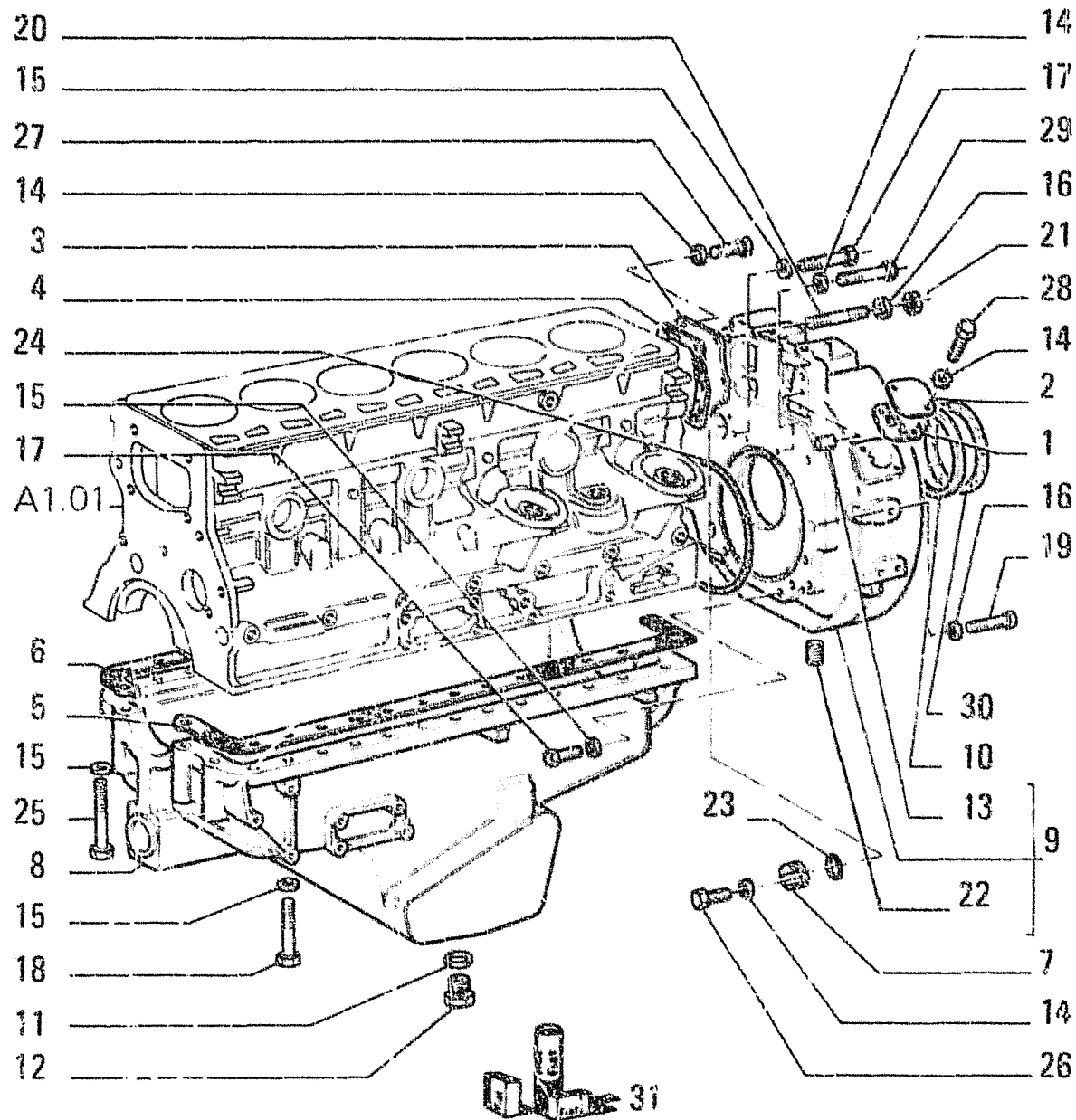

FIATALLIS FD7

A1.02 TAV. 1 PAG.2

ITEM	PART NUMBER	QTY	TRANS CODE	DESCRIPTION	DESCRIZIONE
16	11200171	4	132R	LOCKWASHER 15x32	ROSETTA DI SICUREZZA 15x32
17	11306921	10	40V	SCREW 10x1,25x30	VITE 10x1,25x30
18	11307021	26	40V	SCREW 10x1,25x40	VITE 10x1,25x40
19	11408321	2	40V	SCREW 14x1,5x35	VITE 14x1,5x35
20	11797720	2	210P	STUD 14x1,5x70 C1572	PRIGIONIERO 14x1,5x70 C1572
	11797824	2	210P	STUD 14x1,5x75 D1572	PRIGIONIERO 14x1,5x75 D1572
	13517821	1	210P	STUD 8x1,25x72 D1572	PRIGIONIERO 8x1,25x72 D1572
21	12164011	2	10D	NUT 14x1,5x11	DADO 14x1,5x11
22	14325601	1	50T	PLUG 35x1,5x14	TAPPO 35x1,5x14
23	14463880	1	158G	O-RING 3,53x34,52	GUARNIZIONE O-R 3,53x34,52
24	14483080	1	158G	O-RING 3,53x196,2 C3347	GUARNIZIONE O-R 3,53x196,2 C3347
	14483081	1	158G	O-RING D3347	GUARNIZIONE O-R D3347
25	15972221	3	40V	SCREW 10x1,25x120	VITE 10x1,25x120
26	16043221	1	40V	SCREW 8x1,25x16	VITE 8x1,25x16
27	16043321	6	40V	SCREW 3x1,25x18	VITE 8x1,25x18
28	16043421	4	40V	SCREW 8x1,25x20	VITE 8x1,25x20
29	16043921	2	40V	SCREW 8x1,25x35	VITE 8x1,25x35
30	40002810	1	158G	O-RING - REAR 110x135 C1572	GUARNIZIONE O-R - POSTERIORE 110x135 C1572
	40003800	1	158G	O-RING - REAR 35x55 D1572	GUARNIZIONE O-R - POSTERIORE 35,55 D1572
31	79037439	1	1K	KIT SEE PAGE 9 C1572	KIT VED. PAG.9 C1572
	79062511	1	1K	KIT SEE PAGE 9 D1572	KIT VED. PAG.9 D1572

OIL SUMP AND CRANKCASE COVERS - COPPA E COPERCHI BASAMENTO - CARTER D'HUILE ET COUVERCLES DE BÂTI - OELWANNE UND DECKEL DES KURBELGEHÄUSES - CARTER DE ACEITE Y TAPAS DEL BLOQUE

A1.02 | 1

N.T.R. 200 - 15.10.1990

604.01.131.05

H10

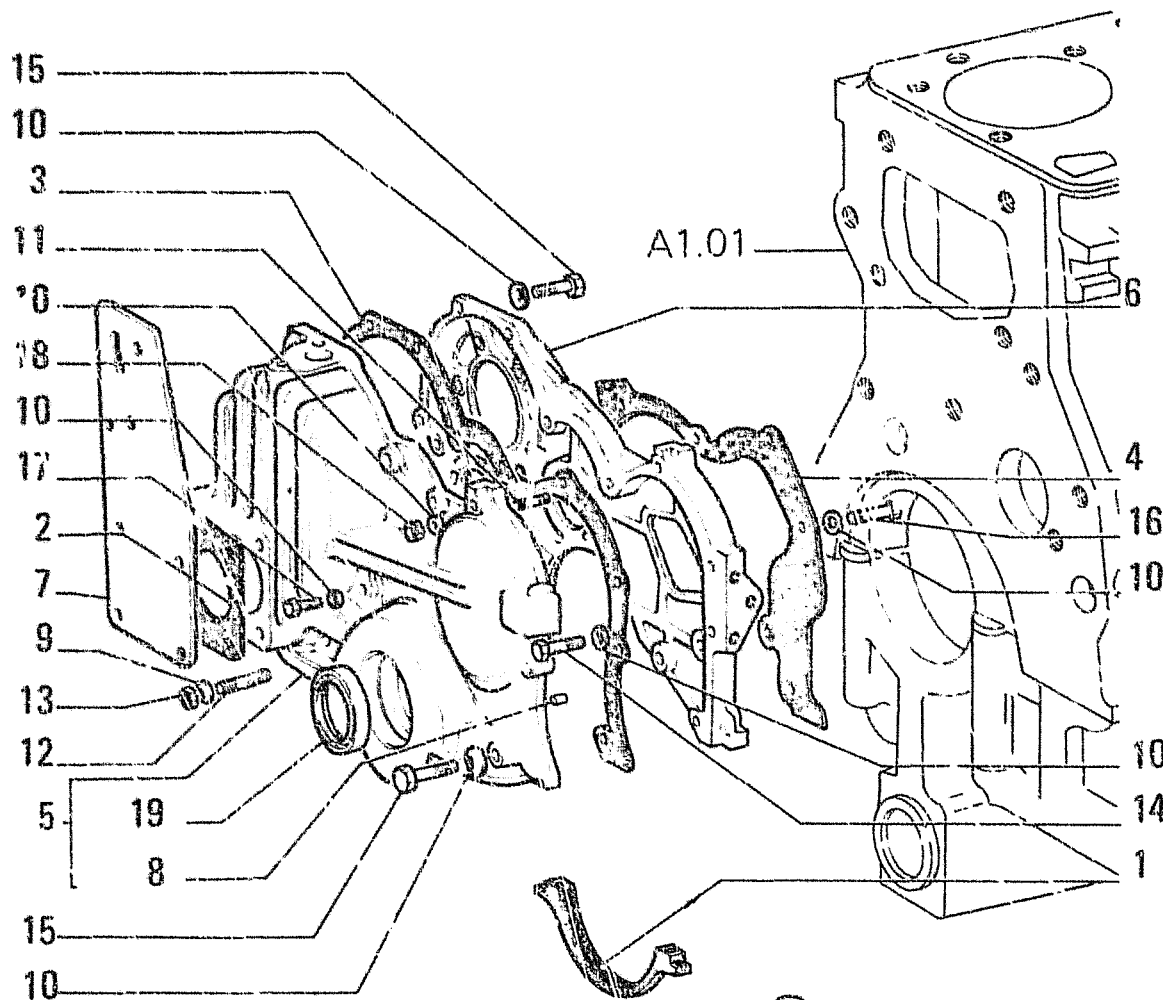

C 1572 → Tel.n. 250904



ITEM	PART NUMBER	QTY	TRANS CODE	DESCRIPTION	DESCRIZIONE
1	4031517	1	123G	SEAL ASSY - FRONT	GUARNIZIONE TENUTA FRONTALE - ANTERIORE
2	4607580	1	123G	SEAL ASSY	GUARNIZIONE TENUTA FRONTALE
3	4607638	1	123C	SEAL ASSY	GUARNIZIONE TENUTA FRONTALE
4	4607639	1	123G	SEAL ASSY	GUARNIZIONE TENUTA FRONTALE
5	4642050	1	265C	COVER - ASSEMBLY	COPERCHIO - COMPLETO
6	4673192	1	35S	COVER	COPERCHIO
7	4705364	1	265C	COVER	COPERCHIO
8	10839610	2	90G	DOWEL 8x12	GRANO 8x12
9	11197771	4	132R	LOCKWASHER 6,4x12	ROSETTA DI SICUREZZA 6,4x12
10	11198071	16	132R	LOCKWASHER 8,2x15	ROSETTA DI SICUREZZA 8,2x15
11	13517720	1	210P	STUD 8x1,25x67	PRIGIONIERO 8x1,25x67
12	13540921	4	210P	STUD 6x1x28	PRIGIONIERO 6x1x28
13	15896221	1	10D	NUT 6x1x5	DADO 6x1x5
14	16043621	1	40V	SCREW 8x1,25x25	VITE 8x1,25x25
15	16043821	1	40V	SCREW 8x1,25x30	VITE 8x1,25x30
16	16044221	1	40V	SCREW 8x1,25x50	VITE 8x1,25x50
17	16044621	4	40V	SCREW 8x1,25x70	VITE 8x1,25x70
18	16100811	1	10D	NUT 8x1,25x6,5	DADO 8x1,25x6,5
19	40000010	1	158G	O-RING - FRONT 42x65	GUARNIZIONE O-R - ANTERIORE 42x65
20	79037439	1	1K	KIT SEE PAGE 9	KIT VED. PAG 9

OIL SUMP AND CRANKCASE COVERS - COPPA E COPERCHI BASAMENTO - CARTER D'HUILE ET COUVERCLES DE BATI - OELWANNE UND DECKEL DES KURBELGEHAUSE - CARTER DE ACEITE Y TAPAS DEL BLOQUE

A1.02

2

N.T.R. 181 - 20.02.1990

604.01.081.03

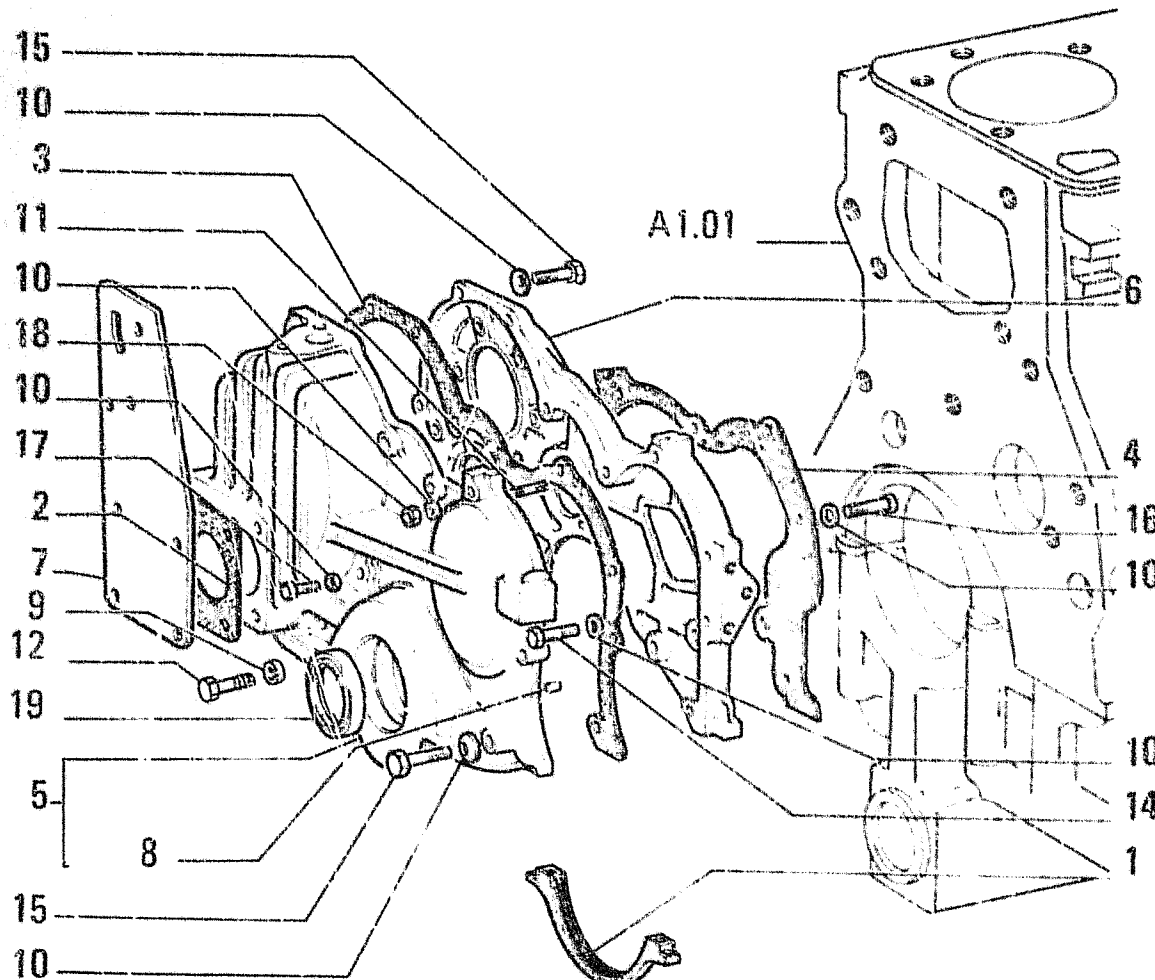

D 1572 Tel.n. 250905 →



ITEM	PART NUMBER	QTY	TRANS CODE	DESCRIPTION	DESCRIZIONE
1	4031577	1	123G	SEAL ASSY - FRONT	GUARNIZIONE TENUTA FRONTALE - ANTERIORE
2	4607590	1	123G	SEAL ASSY C3341	GUARNIZIONE TENUTA FRONTALE C3341
	4858082	1	123G	SEAL D3341	GUARNIZIONE D3341
3	4781578	1	123G	SEAL ASSY	GUARNIZIONE TENUTA FRONTALE
4	4781579	1	123G	SEAL ASSY	GUARNIZIONE TENUTA FRONTALE
5	4772142	1	265C	COVER - ASSEMBLY	COPERCHIO - COMPLETO
6	4766126	1	35S	CASE	SCATOLA
7	4765364	1	265C	COVER	COPERCHIO
8	10839610	2	90G	WOWEL 8x12	GRANO 8x12
9	11197771	4	132R	LOCKWASHER 6,4x12	ROSETTA DI SICUREZZA 6,4x12
10	10519601	16	132R	LOCKWASHER 8,15x17	ROSETTA DI SICUREZZA 8,15x17
11	13517720	1	210P	ST ID 8x1,25x67	PRIGIONIERO 8x1,25x67
12	10902524	4	40V	SCREW 6x1x22	VITE 6x1x22
14	16044921	3	40V	SCREW 8x1,25x85	VITE 8x1,25x85
15	16043921	6	40V	SCREW 8x1,25x35	VITE 8x1,25x35
16	16043521	2	40V	SCREW 8x1,25x22	VITE 8x1,25x22
	16043821	1	40V	SCREW 8x1,25x30	VITE 8x1,25x30
	16044221	1	40V	SCREW 8x1,25x50	VITE 8x1,25x50
17	16044621	2	40V	SCREW 8x1,25x70	VITE 8x1,25x70
18	16100811	1	10D	NUT 8x1,25x6,5	DADO 8x1,25x6,5
19	40000011	1	158G	O-RING 42x65	GUARNIZIONE O-R 42x65
20	79062511	1	1K	KIT SEE PAGE 9	KIT VED. PAG 9

OIL SUMP AND CRANKCASE COVERS - COPPA E COPERCHI BASAMENTO - CARTER D'HUILE ET COUVERCLES DE BATI - OELWANNE UND DECKEL DES KURBELGEHAEUSES - CARTER DE ACEITE Y TAPAS DEL BLOQUE

A1.02

2A

N.T.R. 200 - 15.10.1990

604.01.001.05

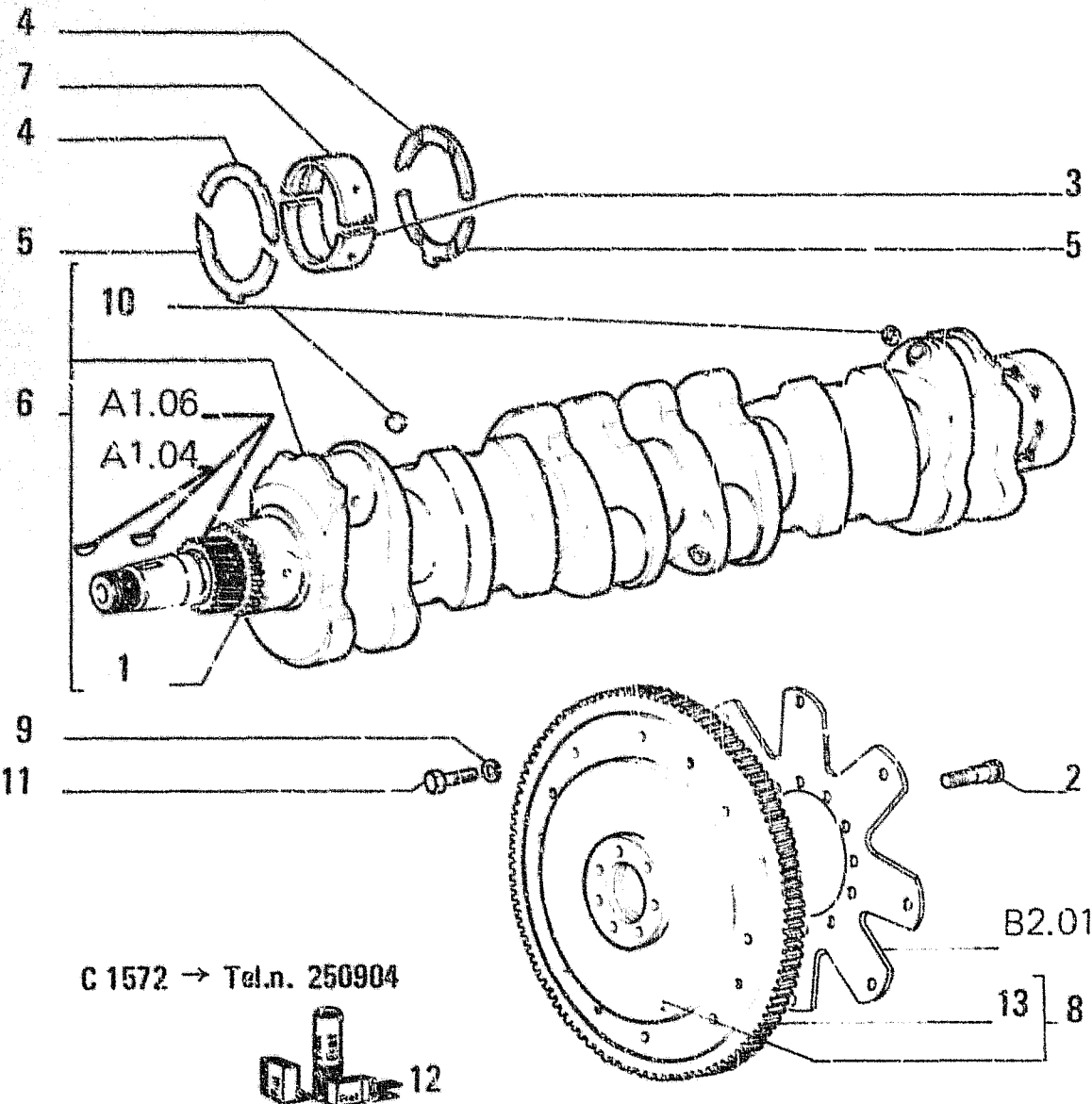

ITEM	PART NUMBER	QTY	TRANS CODE	DESCRIPTION	DESCRIZIONE
1	4680577	1	50I GEAR		INGRANAGGIO
2	4690226	7	40V SCREW		VITE
3	4698683	7	103S HALF BEARING -0,000		SEMICUSCINETTO -0,000
	4698685	7	103S HALF BEARING -0,254		SEMICUSCINETTO -0,254
	4698686	7	103S HALF BEARING -0,508		SEMICUSCINETTO -0,508
	4698687	7	103S HALF BEARING -0,762		SEMICUSCINETTO -0,762
	4698688	7	103S HALF BEARING -1,016		SEMICUSCINETTO -1,016
4	4699805	2	90S HALF RING - UPPER +0,000		SEMIANELLO - SUPERIORE +0,000
	4699806	2	90S HALF RING - UPPER +0,127		SEMIANELLO - SUPERIORE +0,127
5	4699807	2	90S HALF RING - LOWER +0,000		SEMIANELLO - INFERIORE +0,000
	4699808	2	90S HALF RING - LOWER +0,127		SEMIANELLO - INFERIORE +0,127
6	4703073	1	18A CRANKSHAFT - ASSEMBLY		ALBERO MOTORE - COMPLETO
7	4738345	7	103S HALF BEARING -0,000		SEMICUSCINETTO -0,000
	4738347	7	103S HALF BEARING -0,254		SEMICUSCINETTO -0,254
	4738348	7	103S HALF BEARING -0,508		SEMICUSCINETTO -0,508
	4738349	7	103S HALF BEARING -0,762		SEMICUSCINETTO -0,762
	4738350	7	103S HALF BEARING -1,016		SEMICUSCINETTO -1,016
8	4756251	1	48V FLYWHEEL - ASSEMBLY		VOLANO - COMPLETO
9	8273916	8	131R WASHER		ROSETTA
10	14328101	6	50T PLUG 8x4		TAPPO 8x4
11	79013302	8	40V SCREW		VITE
12	1901803	7	1K KIT SEE PAGE 9		KIT VED. PAG 9
	1901804	7	1K KIT SEE PAGE 9		KIT VED. PAG 9
	1901805	7	1K KIT SEE PAGE 9		KIT VED. PAG 9
13	4764904	1	297C RING GEAR		CORONA DENTATA

CRANKSHAFT AND FLYWHEEL - ALBERO E VOLANO MOTORE - VILEBREQUIN ET VOLANT MOTEUR -
 KURBELWELLE UND SCHWUNGRAD - CIGUEÑAL Y VOLANTE

A1.03
 N.T.R. 191 - 20.02.1990
 604.01.081.04

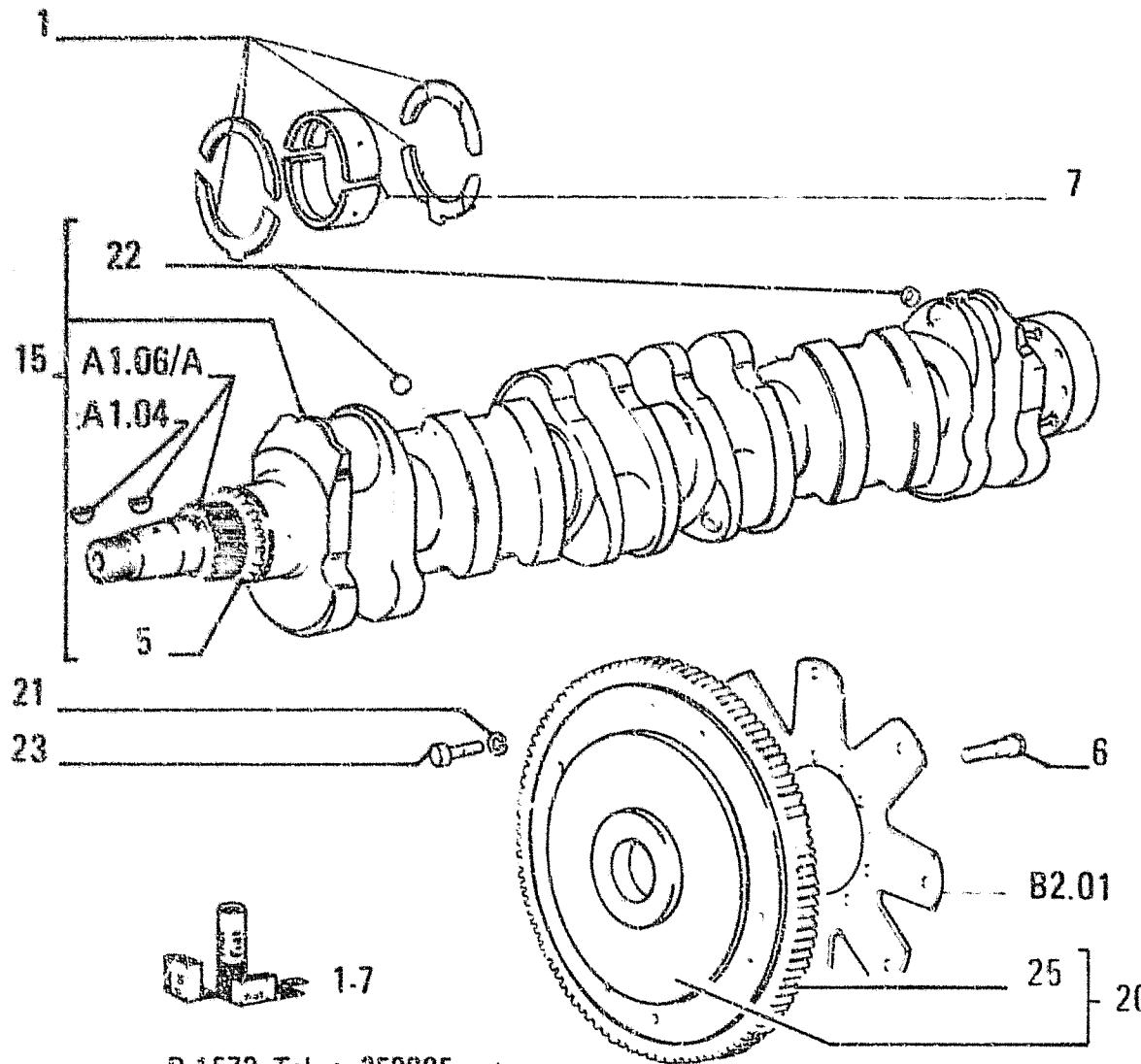

ITEM	PART NUMBER	QTY	TRANS CODE	DESCRIPTION	DESCRIZIONE
1	1901385	1	2K	KIT ANELLI+0,000	KIT ANELLI+0,000
	1901386	1	2K	KIT ANELLI+0,127	KIT ANELLI+0,127
	1901387	1	2K	KIT ANELLI+0,254	KIT ANELLI+0,254
	1901388	1	2K	KIT ANELLI+0,508	KIT ANELLI+0,508
5	4770255	1	50I	GEAR	INGRANAGGIO
6	4779122	7	40V	SCREW	VITE
7	1930176	7	2K	KIT SEMICUSCINETTI-0,000	KIT SEMICUSCINETTI-0,000
	1930177	7	2K	KIT SEMICUSCINETTI-0,254	KIT SEMICUSCINETTI-0,254
	1930178	7	2K	KIT SEMICUSCINETTI-0,508	KIT SEMICUSCINETTI-0,508
	1930179	7	2K	KIT SEMICUSCINETTI-0,762	KIT SEMICUSCINETTI-0,762
	1930180	7	2K	KIT SEMICUSCINETTI-1,016	KIT SEMICUSCINETTI-1,016
15	4785107	1	10A	CRANKSHAFT - ASSEMBLY	ALBERO MOTORE - COMPLETO
20	4805683	1	48V	FLYWHEEL - ASSEMBLY	VOLANO - COMPLETO
21	11108571	8	131R	WASHER 10,5x20	ROSETTA 10,5x20
22	14328101	6	50T	PLUG 8x4	TAPPO 8x4
23	76012151	8	40V	SCREW	VITE
25	4704106	1	297C	RING GEAR	CORONA DENTATA

CRANKSHAFT AND FLYWHEEL - ALBERO E VOLANO MOTORE - VILEBREQUIN ET VOLANT
 MOTEUR - KURBELWELLE UND SCHWUNGRAD - CIGÜEÑAL Y VOLANTE

A1.03/A

N.T.R. 205 - 30.09.1991
 604.01.081.06

H14

VON

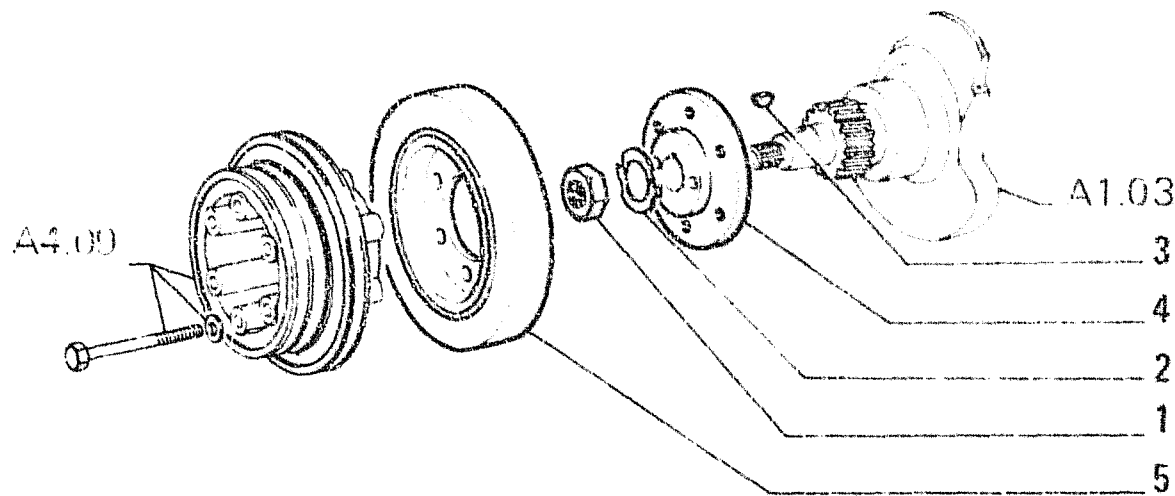

ITEM	PART NUMBER	QTY	TRANS CODE	DESCRIPTION	DESCRIZIONE
1	4600189	1	10D	NUT	DADO
2	4600190	1	113P	LOCKPLATE	PIASTRINA DI SICUREZZA
3	4655844	1	60L	KEY	LINGUETTA
4	4655847	1	135M	HUB	MOZZO
5	4728716	1	164S	DAMPER C1572	SMORZATORE C1572
	4792039	1	164S	DAMPER D1572	SMORZATORE D1572

DAMPER - SMORZATORE PER ALBERO MOTORE - DAMPER DE VILEBREQUIN - SCHWINGUNGSDAEMPFER -
 ANTIVIBRADOR DEL CIGUEÑAL

1
A1.04
 N.T.R. 158 - 13.03.1987
 604.01.081.03

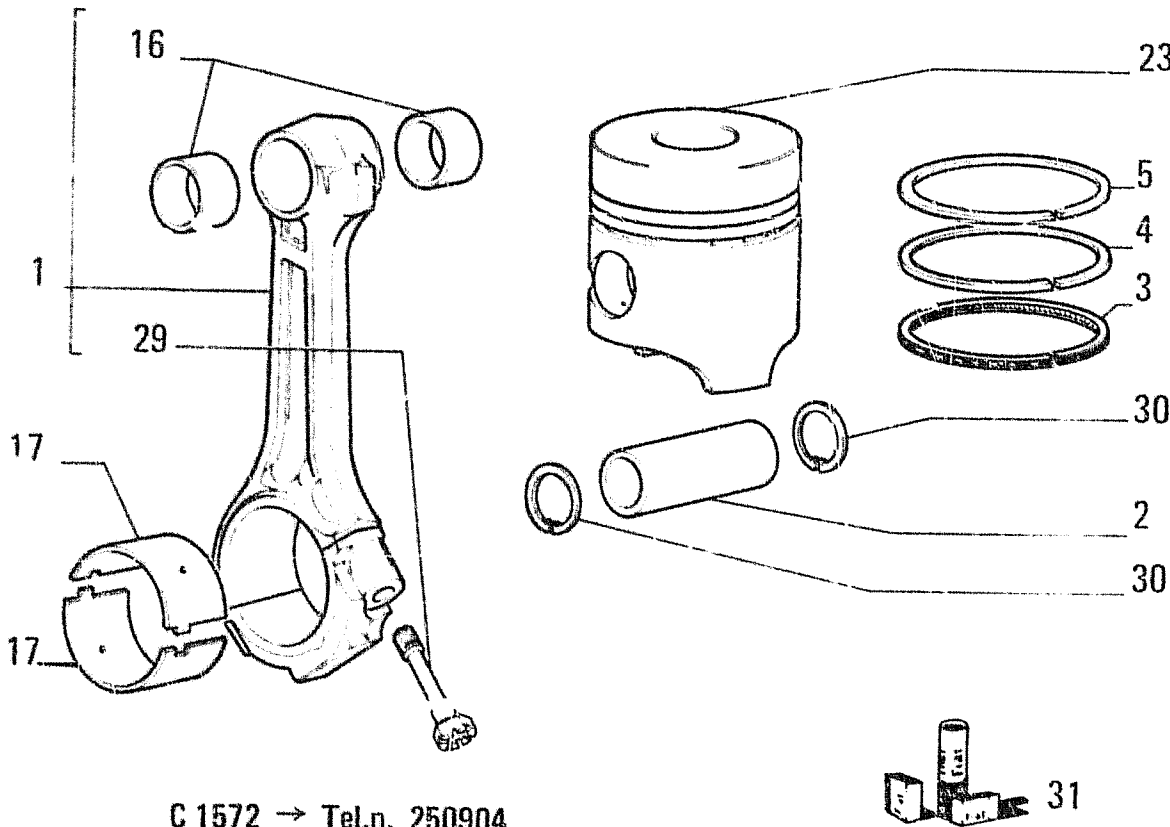

C 1572 → Tel.n. 250904

ITEM	PART NUMBER	QTY	TRANS CODE	DESCRIPTION	DESCRIZIONE
1	4679221	6	50B	LINK - ASSEMBLY	BIELLA - COMPLETO
2	4679224	6	80P	PIN	PERNO
3	4679226	6	50A	OILSCRAPER RING +0.0	ANELLO RASCHIAOLIO +0.0
	4690496	6	50A	OILSCRAPER RING +0.1	ANELLO RASCHIAOLIO +0.1
	4690497	6	50A	OILSCRAPER RING +0.2	ANELLO RASCHIAOLIO +0.2
	4690498	6	50A	OILSCRAPER RING +0.4	ANELLO RASCHIAOLIO +0.4
	4690499	6	50A	OILSCRAPER RING +0.6	ANELLO RASCHIAOLIO +0.6
	4690500	6	50A	OILSCRAPER RING +0.8	ANELLO RASCHIAOLIO +0.8
4	4679227	6	50A	OILSCRAPER RING +0.0	ANELLO RASCHIAOLIO +0.0
	4690501	6	50A	OILSCRAPER RING +0.1	ANELLO RASCHIAOLIO +0.1
	4690502	6	50A	OILSCRAPER RING +0.2	ANELLO RASCHIAOLIO +0.2
	4690503	6	50A	OILSCRAPER RING +0.4	ANELLO RASCHIAOLIO +0.4
	4690504	6	50A	OILSCRAPER RING +0.6	ANELLO RASCHIAOLIO +0.6
	4690505	6	50A	OILSCRAPER RING +0.8	ANELLO RASCHIAOLIO +0.8
5	4679272	6	53A	PISTON RING +0.0	ANELLO STANTUFFO +0.0
	4707725	6	53A	PISTON RING +0.1	ANELLO STANTUFFO +0.1
	4707726	6	53A	PISTON RING +0.2	ANELLO STANTUFFO +0.2
	4707727	6	53A	PISTON RING +0.4	ANELLO STANTUFFO +0.4
	4707728	6	53A	PISTON RING +0.6	ANELLO STANTUFFO +0.6
	4707729	6	53A	PISTON RING +0.8	ANELLO STANTUFFO +0.8
16	4696722	2	95B	BUSHING	BOCCOLA
17	4698677	12	103S	HALF BEARING -0.000	SEMICUSCINETTO -0.000
	4698679	12	103S	HALF BEARING -0.254	SEMICUSCINETTO -0.254
	4698680	12	103S	HALF BEARING -0.508	SEMICUSCINETTO -0.508
	4698681	12	103S	HALF BEARING -0.762	SEMICUSCINETTO -0.762
	4698682	12	103S	HALF BEARING -1.016	SEMICUSCINETTO -1.016
23	4706866	6	235S	PISTON	STANTUFFO

CONNECTING RODS AND PISTONS - BIELLE E STANTUFFI - BIELLES ET PISTONS - PLEUELSTANGEN UND KOLBEN - BIELAS Y EMBOLOS

A1.05

N.T.R. 191 - 20.02.1990

604.01.081.04

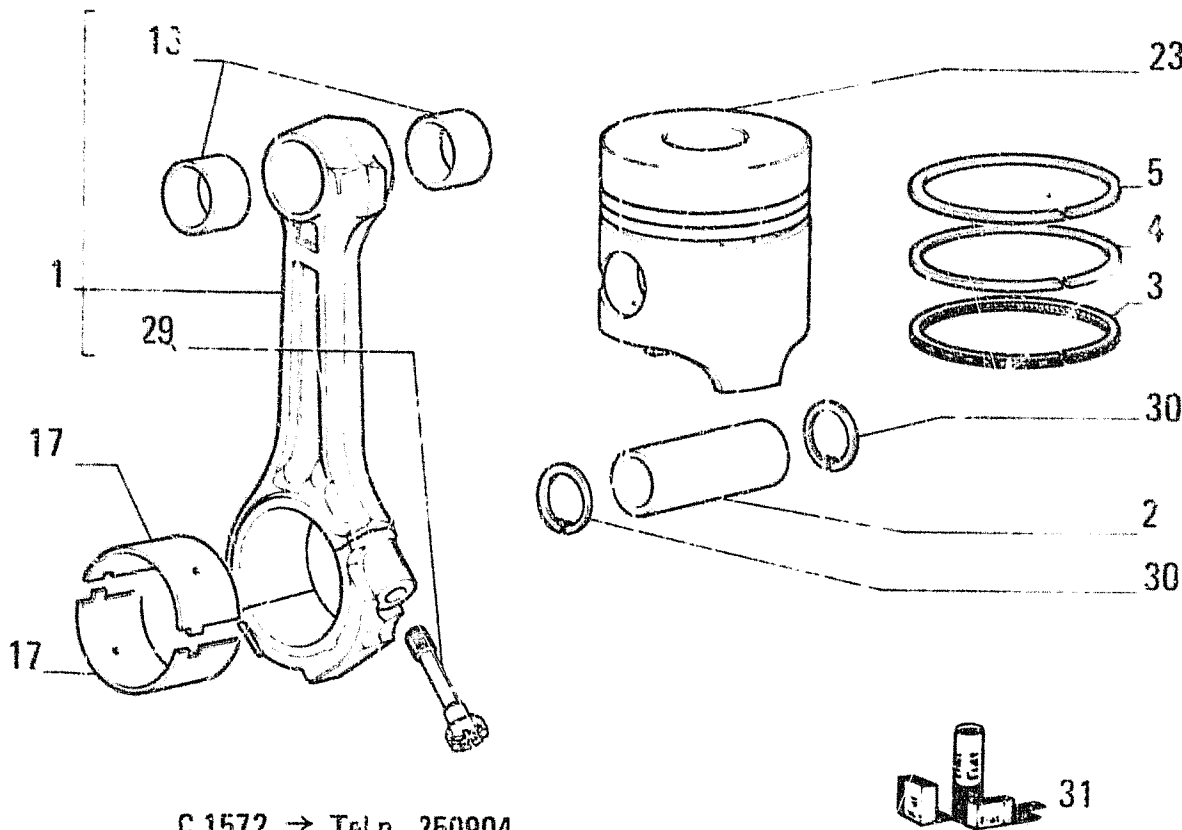

ITEM	PART NUMBER	QTY	TRANS CODE	DESCRIPTION	DESCRIZIONE
29	4762000	2	4CV	SCREW	VITE
30	11059376	12	51A	LOCKRING 36,5x1,5	ANELLO DI SICUREZZA 36,5x1,5
31	1901609	6	1K	KIT SEE PAGE 9	KIT VED PAG 9
	1909234	6	1K	KIT SEE PAGE 9	KIT VED PAG 9
	1909242	6	1K	KIT SEE PAGE 9	KIT VED PAG 9
	79037400	1	1K	KIT SEE PAGE 9	KIT VED PAG 9
	79037501	1	1K	KIT SEE PAGE 9	KIT VED PAG 9

C 1572 → Tel.n. 250904

CONNECTING RODS AND PISTONS - BIELLE E STANTUFFI - BIELLES ET PISTONS - PLEUELSTANGEN UND KOLBEN - BIELAS Y EMBOLOS

A1.05

N.T.R. 191 - 20.02.1990

604.01.081.04

H17

	DESIGNAZIONE BASE	BASIC DESIGNATION	DESIGNATIONS-BASES	GRUNDBEZEICHNUNGEN	DENOMINACIONES BASE
107G	GRUPPO ACCENSIONE ELETTRONICO	ELECTRONIC IGNITION SYSTEM	GRUPE D'ALLUMAGE	ELEKTRONISCHE	SISTEMA DE ENCEN-
107G		UNIT	ELECTRONIQUE	ZUENDUNGS-AUS-	DIDO ELECTRONICO
107G				RUESTUNG	
107S	SEMIPULEGGIA	HALF PULLEY	DEMI-POULIE	SCHEIBENHAELFTE	SEMIPOLEA
1070	CILINDRO INCLINAZIONE	TILT CYLINDER	CYLINDRE DE TILT	TILT ZYLINDER	CILINDRO TILT
1071	CILINDRO TILT (HS-L)	TILT CYLINDER (HS-L)	CYLINDRE DE TILT (HS-L)	TILT ZYLINDER (HS-L)	CILINDRO TILT (HS-L)
1072	CILINDRO TILT (HS)	TILT CYLINDER (HS)	CYLINDRE DE TILT (HS)	TILT ZYLINDER (HS)	
1078	COMANDO ATTREZZO POST.	REAR EQUIPMENT CONTROL	COMMANDE D'OUTIL POSTERIEUR	STEUERUNG HECKANBAUGERAETE	MANDO DEL UTIL. POSTERIOR
109B	BORDO	EDGE	PROFLE	PROFIL	PERFIL
108C	GRUPPO DI RINVIO	IDLER UNIT	GRUPE DE RENVOI	ZWISCHENGETRIEBE	REENVIO-REDUCTOR
108M	MOLTIPLICATORE	OVERDRIVE	SURMULTIPLICATEUR	DREHMOMENTVERSTAERKER	MULTIPLICADOR
108R	RITARDATORE IDRAULICO	HYDRAULIC RETARDER	RETARDATEUR HY-	HYDRAULISCHE VERZO	RETARDADOR HIDRAU-
108R			DRALIQUE	GERUNGSVORRICHTUNG	LICO
108S	SEMISTANTUFFO	HALF PISTON	DEMI-PISTON	KOLBENHAELFTE	SEMIEMBOLO
1082	COMANDO E TUBAZIONI	PIPING AND CONTROL	COMMANDE ET TUYANTERIE	STEUERUNG UND LEITUNGEN	
1083	COMANDO II CASSETTO	2ND SPOOL CONTROL	COMMANDE DU 2ME TIROIR	BETAETIGUNG DES 2 STEUERKREISE	
1084	COMANDO III CASSETTO	3RD SPOOL CONTROL	COMMANDE DU 3ME TIROIR	BETAETIGUNG DES 3 STEUERKREISE	MANDO DE LA 3A CARRETES
1087	COMANDO E TUBAZ(DAL DEVIATORE)	PIPING AND CONTR(DIVERT VALVE)	COMMANDE ET TUYANTERIE(DEVIA	STEUERUNG LEITUNG(VOM UMSCHALT	
109B	BORSA PORTACARTE	UTILITY RECESS	VIDE-POCHES	ABLEGEFACH	BOLSA PARA MAPAS
109G	GRUPPO INIEZIONE	INJECTION EQUIPMENT	GRUPE D'INJECTION	EINSPRITZAUS-	GRUPO DE INYECCION
109G				RUESTUNG	
109S	MENSOLE INCERNIERAM	TRUNNIONS	CONSOLES	KUGELBOLZEN	REFUERZOS
110A	ATTREZZO ANTERIORE	FRONT IMPLEMENT	EQUIPEMENT AVANT	VORNEINRICHTUNG	IMPLEMENTO ANTERIOR
110C	BRACCI E ARTICOLAZIONI	BOOM/LINKAGE	ARTICULATION DE FLECHE	HUBARM UND UMLENKHEBEL	ARTICULACION DEL AIGULON
1101	CILINDRI SOLLEVAMENTO	LIFT CYLINDERS	CYLINDRES LEVAGE	HUBZYLINDER	CILINDRO ALCE
1102	CILINDRI ROTAZIONE BENNA	DUMP CYLINDERS	CYLINDRES DECHARGE	KIPPZYLINDER	CILINDRO DESCARGA
1103	TUBAZIONI CILINDRI SOLLEV	LIFT CYLINDERS PIPING	CONDUITES CYLINDRES LEVAGE	LEITUNGEN FUER HUBZYLINDER	TUBERIA CILINDRO ALCE
1104	TUBAZIONI CILINDRI ROTAZIONE	DUMP CYLINDERS PIPING	TUYAUTERIE CYLINDRES BASCULAGE	LEITUNGEN FUER KIPPZYLINDER	
1105	COMANDI ATTREZZO	EQUIPMENT CONTROLS	COMMANDES D'OUTIL		MANDO DEL UTIL
1108	LIMITAZIONE SOLLEV. BRACCI	LIFTING KICK-OUT		HUBBEGRENZUNG	
110A	AVVOLGIMENTO	WINDING	ENROULEMENT	WICKLUNG	BOBINA
110F	FUSIBILE	FUSE	FUSIBLE	SICHERUNG	FUSIBLE
110G	GRUPPO OTTICO	LENS/REFLECTOR UNIT	GRUPE OPTIQUE	EINSATZ	GRUPO OPTICO
110P	PIASTRINA	PLAQUE	PLAQUETTE	PLAETTCHEN	CHAPITA
110T	TESTA A SNODO	ARTICULATED JOINT	JOINT A ROTULE	GELENKKOPF	ARTICULACION
1103	TUBAZ. CON VALVOLA DEFLUSSO	PIPING W/DOWNFLOW VALVE	TUYAUTERIE AVEC SOUPAPE DE DEF	SCHNELLENKVENTIL	
1107	VALVOLA DISCESA RAPIDA	QUICK RELEASE VALVE	SOUFRAGE DESCENTE RAPIDE	RUECKSCHLAGVENTIL	
1108	VALVOLA DI BLOCCO	LOCK VALVE	SOUFRAGE DE BLOCAGE	ELEKTROKABEL	CABLE
111C	CAVO	CABLE	CABLE	REGLERGRUPPE	REGULADOR
111G	GRUPPO DI REGOLAZIONE	GOVERNOR ASSEMBLY	GRUPE REGULATEUR		

DESIGNAZIONE BASE	BASIC DESIGNATION	DESIGNATIONS-BASES	GRUNDBEZEICHNUNGEN	DENOMINACIONES BASE
101G	GRIGLIA	GRID	GRILLE	REJILLA
1011	FORCELLE	STRUTS	FOURCHES	
101P	FORCELLE RINFORZATE	STRUTS H.D	FOURCHES RENFORCEES	
102B	BOMBOLETTA	BOTTLE	ROUTEILLE	ENVASE DE GAS
102E	ELEVATORE	ELEVATOR	ELEVATEUR	ELEVADOR
102G	GRU	CRANE	GRUE	GRUA
102P	PIANALE	PLATFORM	PLATEAU	PLATAFORMA
1022	LASERPLANE-TRASMETTITORE		LASERPLANE TRANSMETTEUR	
1023	LASERPLANE-RICEVITORE		LASERPLANE RECEPTEUR	
103A	ASTUCCIO PORTARULLI	ROLLER CASING	ETUI PORTE-GALET	CARTER PORTARRO- DILLOS
103A				
103E	ESPULSORE	EJECTOR		
103N	MOLLA A DIAFRAMMA	DISC SPRING	RONDELLE-RESSORT	DIAFRAGMA DE MUE- LLE
103M				
103P	PIANTONE	STEERING COLUMN	COLONNE DIRECTION	COLUMNA DIRECCION
103S	SEMICUSCINETTO	HALF BEARING	DEMI-ROULEMENT	SEMIRODAMIENTO
103G	CILINDRI ANGOLAZIONE	ANGLE CYLINDERS	CYLINDRES AD	
104A	ATTACCO PER ATTREZZI	EQUIPMENT MOUNTING	ATTELAGE DES OU- TILS	ENGANCHE DE LOS UTILES
104A				
104G	GRUPPO COMANDO DI DISTRIBUZION	CAMSHAFT DRIVE SET	JEU DE COMMANDE DE DISTRIBUTION	JUEGO DE PINONES DE LA DISTRIBUCION
104G	NE			
104S	SEMIDISCO	HALF DISC	DEMI-DISQUE	SEMIDISCO
1040	BRACCI E TIRANTI (HSU-HS)	PUSHBEAMS AND STRUTS (HSU-HS)	BRAS ET TIRANTS (HSU-HS)	BRAZOS Y TIRANTES (HSU-HS)
1041	BRACCI E TIRANTI (HS-L)	PUSHBEAMS AND STRUTS (HS-L)	BRAS ET TIRANTS (HS-L)	BRAZOS Y TIRANTES (HS-L)
1042	BRACCI E TIRANTI (HS)	PUSHBEAMS AND STRUTS (HS)	BRAS ET TIRANTS (HS)	BRAZOS Y TIRANTES (HS)
1043	BRACCI E TIRANTI (TILT-PITCH)	PUSHBEAMS & STRUTS(TILT-PITCH)	BRAS ET TIRANTS (TILT-PITCH)	BRAZOS Y TIRANTES (TILT-PITCH)
105A	AVVISATORE ACUSTICO	HORN	AVERTISSEUR	BOCINA
105F	FUNE	CABLE	CABLE	CABLE
105G	GRUPPO DI ROTAZIONE	ROTATION UNIT	GROUPE DE ROTATION	GRUPO DE ROTACION
105M	MOLLETTA	SPRING FASTENER	AGRAFE	SUJETADOR
105P	PIASTRA	PLATE	PLAQUE	PLACA
105R	RISCALDATORE	HEATER	RECHAUFFEUR	CALENTADOR
105S	SEMIGIUNTO	HALF COUPLING	DEMI-JOINT	SEMIACOPLAMIENTO
106B	BORDINO	MOLDING	PROFILE	PERFIL
106G	GRUPPO AMMORTIZZANTE	SHOCK ABSORBING UNIT	GROUPE AMORTISSEUR	GRUPO AMORTIGUADOR
106R	RISCALDATORE ELETTRICO	HEATING ELEMENT	RECHAUFFEUR ELEC- TRIQUE	RESISTENCIA DE CALDEO
106R				
106S	SEMIGUARNIZIONE	HALF GASKET	DEMI-JOINT	SEMIGUARNICION
106S				
1065	CILINDRO TILT (ALL-HYDRAULIC)	TILT CYLINDER (ALL-HYDRAULIC)	CYLINDRE DE TILT(ALL-HYDRAULIC)	
107B	BORDO DI GOMMA	WEATHERSTRIP	CAOUTCHOUC	GOMA

DESIGNAZIONE BASE	BASIC DESIGNATION	DESIGNATIONS-BASES	GRUNDBEZEICHNUNGEN	DENOMINACIONES BASE
EL	ELIMINATO	DELETED	ELIMINE	ELIMINADO
ERR	ERRATA	WRONG	ERRATA	DONDE DICE
EST	ESTERNO	OUTER	EXTERIOR	EXTERIOR
FAC0	AGRICOLA A CINGOLI	AGRICULTURAL CRAWLER	TRACT.AGRICOLE SUR CHENILLES	TRACTOR AGRICOLA SOBRE ORUGAS
FBC0	TERNA	BACKHOE LOADER	CHARGEUSE-PELLETEUSE	TERNA SOBRE RUEDAS
FD0P	APRIPISTA CINGOLI LGP	CRAWLER DOZER-LGP	BOUTEUR SUR CHENILLES LGP	ABRETROCHAS LGP
FD0D	APRIPISTA CINGOLI	CRAWLER DOZER	BOUTEUR SUR CHENILLES	ABRETROCHAS
FE0P	ESCAVATORE A CINGOLI LC	CRAWLER EXCAVATOR-LC	PELLE SUR CHENILLES LC	EXCAVADORA SOBRE ORUGAS LC
FE0R	ESCAVATORE A CINGOLI HD	CRAWLER EXCAVATOR-HD	PELLE SUR CHENILLES HD	EXCAVADORA SOBRE ORUGAS HD
FE0W	ESCAVATORE A RUOTE	WHEEL EXCAVATOR	PELLE SUR PNEUS	EXCAVADORA SOBRE RUEDAS
FE0D	ESCAVATORE A CINGOLI	CRAWLER EXCAVATOR	PELLE SUR CHENILLES	EXCAVADORA SOBRE ORUGAS
FG0D	MOTOLIVELLATRICE	MOTOR-GRADER	NIVELEUSE SUR PNEUS	MOTONIVELADORA
FL0P	CARICATORE A CINGOLI LGP	CRAWLER LOADER-LGP	CHARGEUSE SUR CHENILLES LGP	CARGADORA SOBRE ORUGAS LGP
FL0D	CARICATORE A CINGOLI	CRAWLER LOADER	CHARGEUSE SUR CHENILLES	CARGADORA SOBRE ORUGAS
FP0D	POSATUBI	PIPE-LAYER	POSEUR DE TUBES	TIENDETUBOS
FR0C	COMPATTATORE A RUOTE	WHEEL COMPACTOR		
FR0D	CARICATORE ART RUOTE	WHEEL LOADER	CHARGEUSE SUR PNEUS	CARGADORA SOBRE RUEDAS
FS0D	MOTORUSPA	MOTOR-SCRAPER	DECAPEUSE SUR PNEUS	MOTOTRAILLA
G214	TRASLAZIONE RETROESCAVATORE	BACKHOE TRASLATION		
INF	INFERIORE	LOWER	INFERIEUR	INFERIOR
INT	INTERNO	INNER	INTERIEUR	INTERIOR
LAT	LATERALE	SIDE	LATERAL	LATERAL
POST	POSTERIORE	REAR	ARRIERE	POSTERIOR
SALD	DA SALDARE	TO BE WELDED	A SOUDER	SOLDAR
SEM	SEMILAVORATO	SEMIFINISHED	MI-OUVRE	SFMIELABORADJ
SN	SINISTRO	LEFT	GAUCHE	IZQUIERDO
SP	SPESSORE	THICKNESS	EPAISSEUR	GRUESO
SUP	SUPERIORE	UPPER	SUPERIOR	SUPERIOR
VED	VEDERE SGR	SEE SGR	VOIR SGR	VEASE SGR
10G3	ARRESTO MOTORE	ENGINE STOP	ARRET DU MOTEUR	PARO DEL MOTOR
100B	BCCOLA DI GOMMA	RUBBER BUSH	BAGUE CAOUTCHOUC	COJINETE DE CAUCHO
100C	CAVALLOTTO	RETAINER	ARRETOIR	SUJETADOR
100G	GRIGLIA DEL RADIATORE	RADIATOR GRILLE	GRILLE DE RALIA- TEUR	CORAZA DEL RADIA- DOR
100M	MOLLA	SPRING	RESSORT	MUELLE
100R	RIPOSTIGLIO CRUSCOTTO	RECESS	BOITE A GANTS	GUANTERA
100S	SEMICONO	LOCK CONE	DEMI-CONE	CHAVETA CONICA
1003	ARCONI (ALL-HYDRAULIC)	C-FRAME (ALL-HYDRAULIC)	ETIER (ALL-HYDRAULIC)	ARCON (ALL-HYDRAULIC)
101A	ASTUCCIO	CASING	ETUI	ESTUCHE
101E	ELETTROLITO	ELECTROLYTE	ELECTROLYTE	ELECTROLYTE

A

ENGINE • MOTORE • MOTEUR • MOTOR • MOTOR

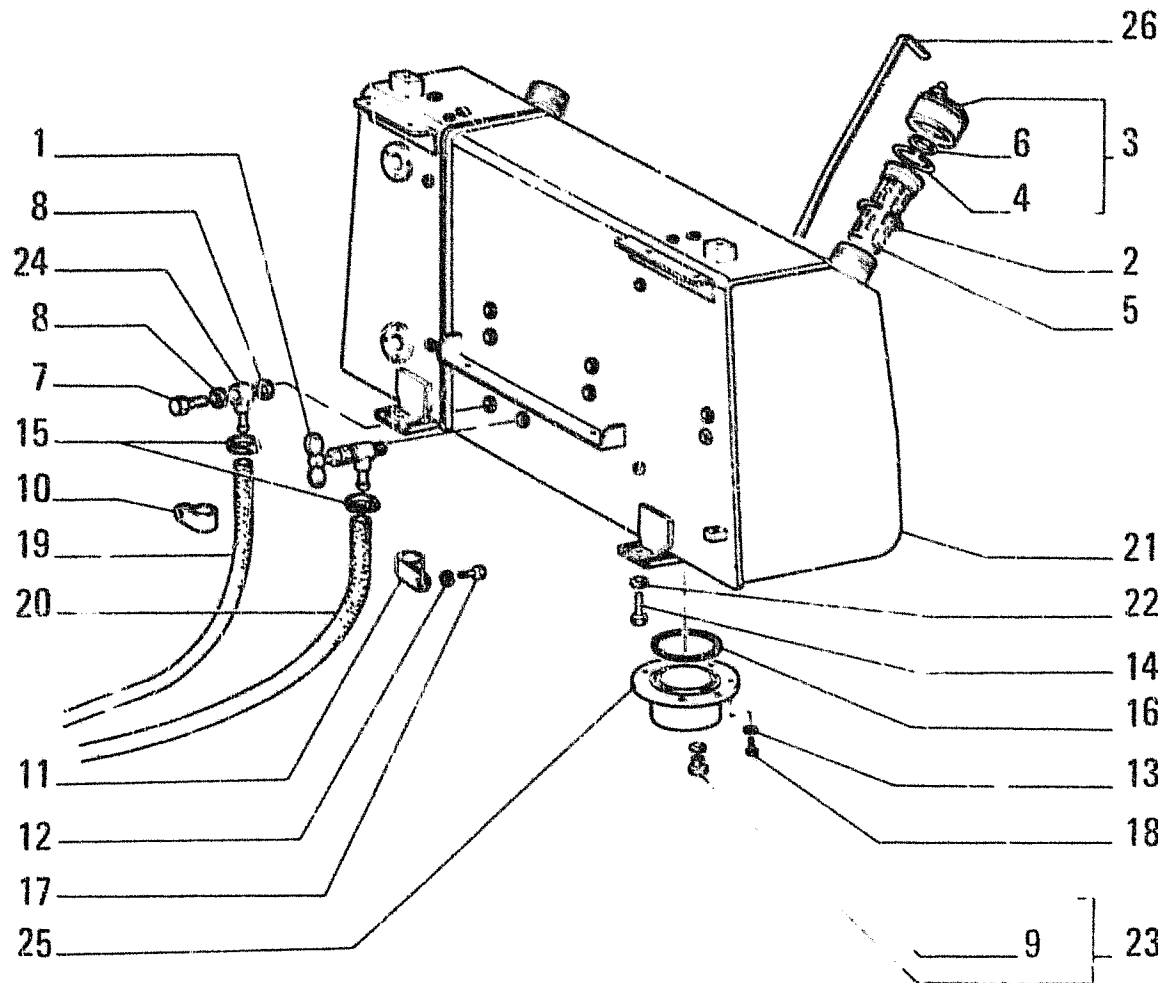

ITEM	PART NUMBER	QTY	TRANS CODE	DESCRIPTION	DESCRIZIONE
1	4966618	1	150R	COCK	RUBINETTO
2	4971843	1	51A	LOCKRING	ANELLO DI SICUREZZA
3	4977118	1	50T	PLUG - ASSEMBLY	TAPPO - COMPLETO
4	4977122	1	51A	LOCKRING	ANELLO DI SICUREZZA
5	4982644	1	64F	FUEL FILTER C1614	FILTRO COMBUSTIBILE C1614
	79043879	1	64F	FUEL FILTER D1614	FILTRO COMBUSTIBILE D1614
6	60024509	1	133R	SEAL	ROSETTA DI TENUTA
7	10184317	1	20R	FITTING 14x1,5x27	RACCORDO 14x1,5x27
8	10279985	2	133R	SEAL 14,2x20	ROSETTA DI TENUTA 14,2x20
9	10296685	1	133R	SEAL 16,2x22 C2907	ROSETTA DI TENUTA 16,2x22 C2907
	14437985	1	158G	O-RING D2907	GUARNIZIONE O-R D2907
10	10450390	2	231S	CLIP 14x9	STAFFETTA 14x9
11	10450790	4	231S	CLIP 22x9	STAFFETTA 22x9
12	10511771	6	132R	LOCKWASHER 10x16	ROSETTA DI SICUREZZA 10x16
13	10571771	6	132R	LOCKWASHER 8,1x2	ROSETTA DI SICUREZZA 8,1x2
14	11112631	8	40V	SCREW 12x1,75x35	VITE 12x1,75x35
15	12179490	4	180C	COLLAR 9/16x8 C2875	COLLARE 9/16x8 C2875
	79084752	4	180C	COLLARI D2875	COLLARE D2875
16	14466589	1	158G	O-RING 3,53x117,7	GUARNIZIONE O-R 3,53x117,7
17	16043031	6	40V	SCREW 8x1,25x12	VITE 8x1,25x12
18	16043631	6	40V	SCREW 8x1,25x25	VITE 8x1,25x25
19	19053182	L	285T	HOSE 7x12 C2875	TUBO FLESSIBILE 7x12 C2875
	76014545	L	285T	HOSE 3,000M D2875	TUBO FLESSIBILE 3,000M D2875

FUEL TANK AND LINES - SERBATOIO COMBUSTIBILE E TUBAZIONI - RESERVOIR ET CANALISATIONS
COMBUSTIBLE - KRAFTSTOFFTANK UND LEITUNGEN - DEPÓSITO DE COMBUSTIBLE Y TUBERÍAS

A2.01

N.T.R. 205 - 30.09.1991
604.01.081.06

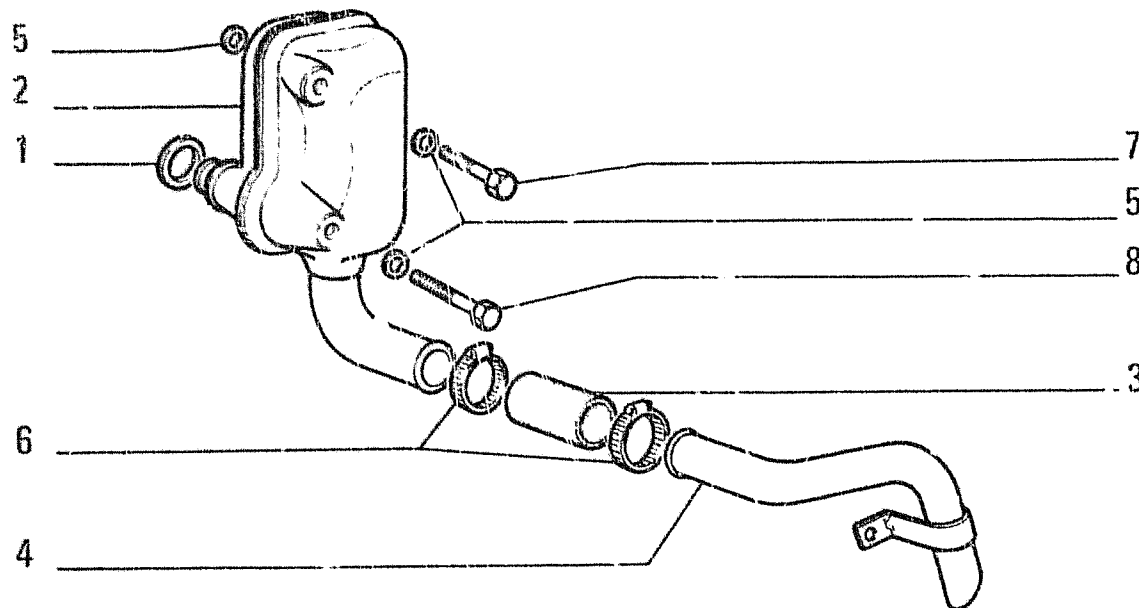

I T E M	PART NUMBER	Q T Y	TRANS CODE	DESCRIPTION	DESCRIZIONE
1	4600893	1	123G	SEAL ASSY	GUARNIZIONE TENUTA FRONTALE
2	4724739	1	145S	BREATHER C1572	SFIATATOIO C1572
	4769877	1	145S	BREATHER D1572	SFIATATOIO D1572
3	4725351	1	30M	SLEEVE	MANICOTTO
4	4765449	1	193T	TUBE C1572	TUBO RIGIDO C1572
	4774892	1	193T	TUBE D1572	TUBO RIGIDO D1572
5	10260060	3	131R	WASHER 8,2x14	ROSETTA 8,2x14
6	12174090	2	180C	COLLAR 32/52x14 C1572	COLLARE 32/52x14 C1572
	12183190	2	180C	COLLAR 33/37 D1572	COLLARE 33/37 D1572
7	16044921	1	40V	SCREW 8x1,25x85	VITE 8x1,25x85
8	16045621	1	40V	SCREW 8x1,25x120	VITE 8x1,25x120
9	79037439	1	1K	KIT SEE PAGE 9 C1572	KIT VED. PAG 9 C1572
	79062511	1	1K	KIT SEE PAGE 9 D1572	KIT VED. PAG 9 D1572

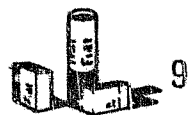

ENGINE BREATHER LINES - TUBAZIONI PER AERAZIONE MOTORE - TUYAUTERIES DE VENTILATION
DU MOTEUR - BELUEFTUNGSLEITUNGEN FUER MOTOR - TUBERIAS DE VENTILACION DEL MOTOR

A1.25

N.T.R. 191 - 20.02.1990

604.01.081.04

573

FIATALLIS FD7

A1.16/ A TAV. 1 PAG.1

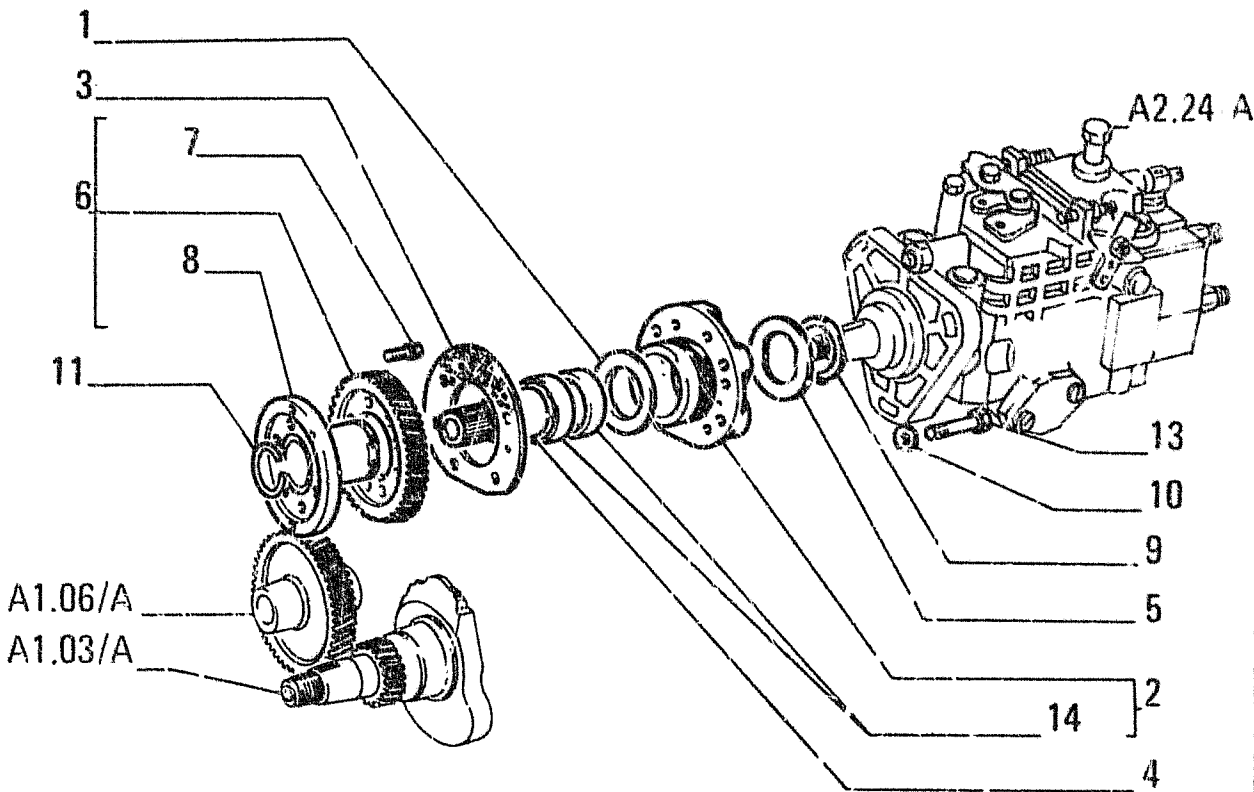

ITEM	PART NUMBER	QTY	TRANS CODE	DESCRIPTION	DESCRIZIONE
1	4809425	1	131R	WASHER	ROSETTA
2	4769710	1	300S	SUPPORT - ASSEMBLY	SUPPORTO - COMPLETO
3	4769429	1	123G	SEAL ASSY C3341	GUARNIZIONE TENUTA FRONTALE C3341
	4858792	1	122G	SEAL D3341	GUARNIZIONE D3341
4	4799061	1	67G	COUPLING	GIUNTO
5	4667498	1	131R	WASHER	ROSETTA
6	4788908	1	50I	GEAR - ASSEMBLY	INGRANAGGIO - COMPLETO
7	4798844	8	40V	SCREW	VITE
8	4788909	1	33M	DRAG SLEEVE	MANICOTTO DI TRASCINAMENTO
9	4770452	1	51A	LOCKRING	ANELLO DI SICUREZZA
10	10519601	6	132R	LOCKWASHER 8,15x17	ROSETTA DI SICUREZZA 8,15x17
11	4708213	1	51A	LOCKRING	ANELLO DI SICUREZZA
13	16043324	1	40V	SCREW 8x1,25x18	VITE 8x1,25x18
	16043624	5	40V	SCREW 8x1,25x25	VITE 8x1,25x25
14	4769427	2	95B	BUSHING	BOCCOLA

D 1572 Tel. n. 250905

INJECTION PUMP DRIVE - COMANDO POMPA INIEZIONE - COMMANDE DE POMPE
 D'INJECTION - EINSPRITZPUMPENANTRIEB - ARRASTRE DE LA BOMBA DE
 INYECCION

A1.16/A

N.T.R. 200 - 15.10.1990
 604.01.081.05

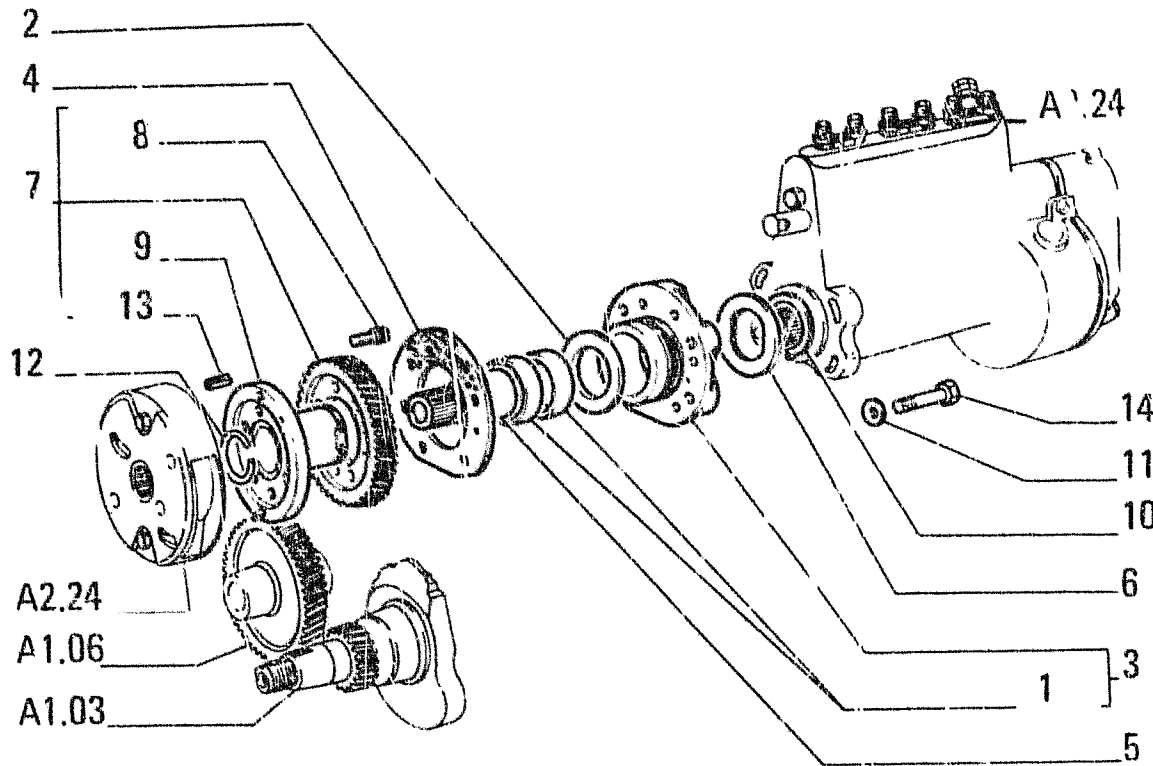

ITEM	PART NUMBER	QTY	TRANS CODE	DESCRIPTION	DESCRIZIONE
1	4601834	2	95B	BUSHING	BUCCOLA
2	4004833	1	131R	WASHER	ROSETTA
3	4607663	1	300S	SUPPORT - ASSEMBLY	SUPPORTO - COMPLETO
4	4607665	1	123G	SEAL ASSY	GUARNIZIONE TENUTA FRONTALE
5	4640558	1	67G	COUPLING	GIUNTO
6	4667498	1	131R	WASHER	ROSETTA
7	4751087	1	50I	GEAR - ASSEMBLY	INGRANAGGI - COMPLETO
8	4751088	6	40V	SCREW	VITE
9	4751089	1	33M	DRAG SLEEVE	MANICOTTO DI TRASCINAMENTO
10	11069375	1	51A	LOCKRING 45,0x2	ANELLO DI SICUREZZA 45,0x2
11	11198071	6	132R	LOCKWASHER 8,2x15	ROSETTA DI SICUREZZA 8,2x15
12	13401675	1	51A	LOCKRING 28,2x32,2	ANELLO DI SICUREZZA 28,2x32,2
13	14600770	1	200S	PIN 5x18	SPINA 5x18
14	18043421	6	40V	SCREW 8x1,25x20	VITE 8x1,25x20

C 1572 → Tel.n. 250904

INJECTION PUMP DRIVE - COMANDO POMPA INIEZIONE - COMMANDE DE POMPE D'INJECTION -
 EINSPIRITZPUMPENANTRIEB - ARRASTRE DE LA BOMBA DE INYECCION

A1.16

N.T.R. 158 - 13.03.1987

604.01.081.03

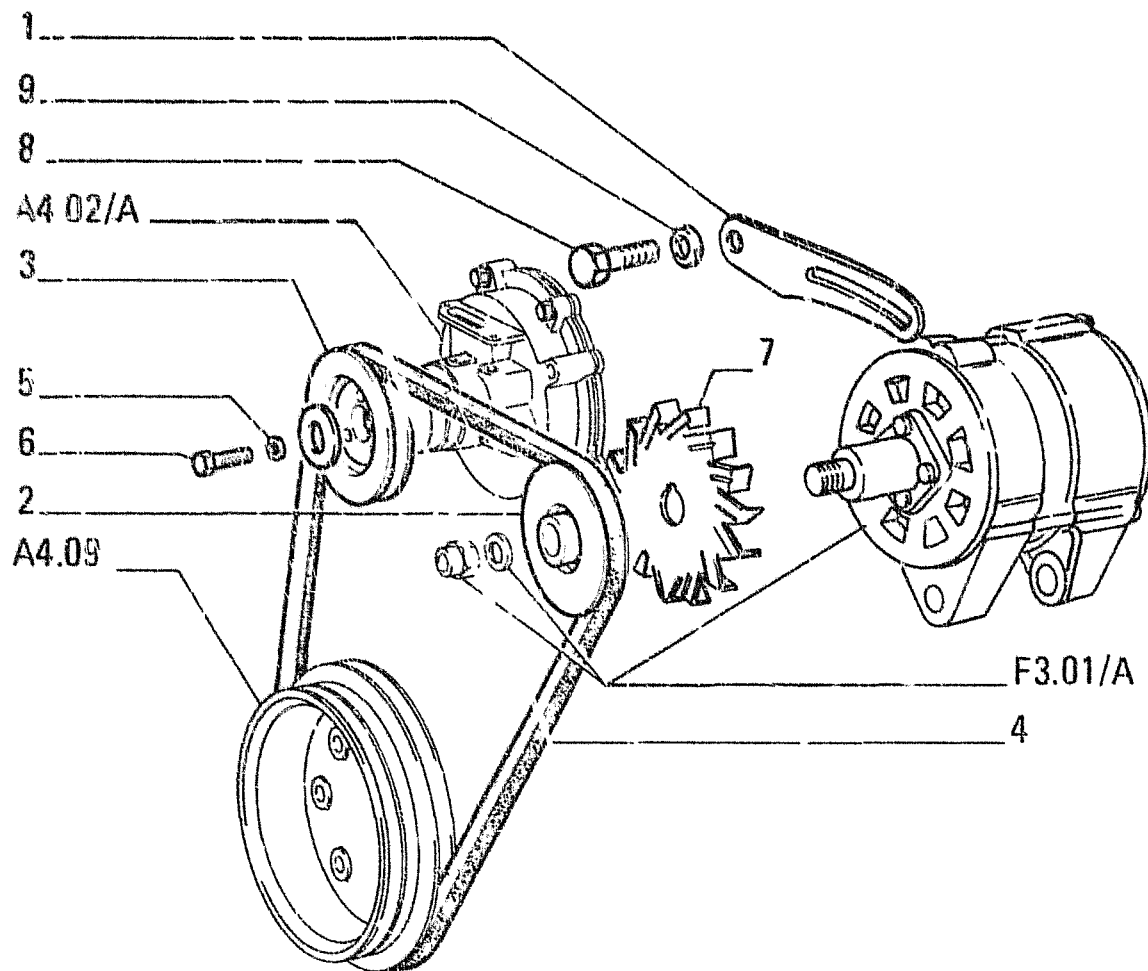

ITEM	PART NUMBER	QTY	TRANS CODE	DESCRIPTION	DESCRIZIONE
1	4806133	1	67T	BELT STRETCHER	TENDICINGHIA
2	4774408	1	230P	PULLEY	PULEGGIA
3	4758240	1	230P	PULLEY	PULEGGIA
4	4806010	1	173C	BELT	CINGHIA
5	11193871	3	132R	LOCKWASHER 8,4x16	ROSETTA DI SICUREZZA 8,4x16
6	16043321	3	40V	SCREW 8x1,25x18	VITE 8x1,25x18
7	4717026	1	36V	BLOWER	VENTOLA
8	4605854	1	40V	SCREW	VITE
9	12642401	1	132R	LOCKWASHER	ROSETTA DI SICUREZZA

D 1572 Tel. n. 250905 →

AUXILIARY DRIVES - COMANDI VARI - COMMANDES DIVERSES - VERSCHIEDENE ANTRIEBE --
MANDOS VARIOS

A1.15/A

N.T.R. 158 - 13.03.1987
604.01.081.03

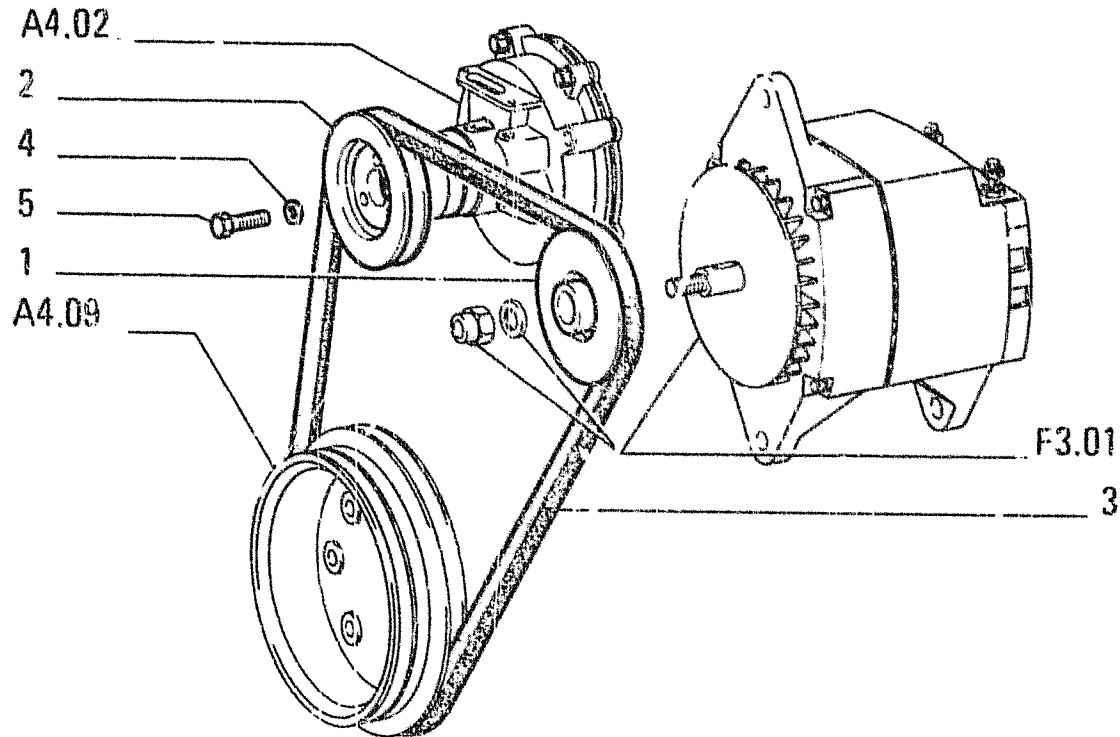

I T E M	PART NUMBER	Q T Y	TRANS CODE	DESCRIPTION	DESCRIZIONE
1	4754871	1	230P	PULLEY	PULEGGIA
2	4758240	1	230P	PULLEY	PULEGGIA
3	4760486	1	173C	BELT	CINGHIA
4	11193871	3	122R	LOCKWASHER 8,4x16	ROSETTA DI SICUREZZA 8,4x16
5	16043321	3	40V	SCREW 8x1,25x18	VITE 8x1,25x18

C 1572 → Tel.n. 250904

AUXILIARY DRIVES - COMANDI VARI - COMMANDES DIVERSES - VERSCHIEDENE ANTRIEBE -- MANDOS
VARIOS

A1.15

N.T.R. 158 - 13.03.1987

604.01.081.03

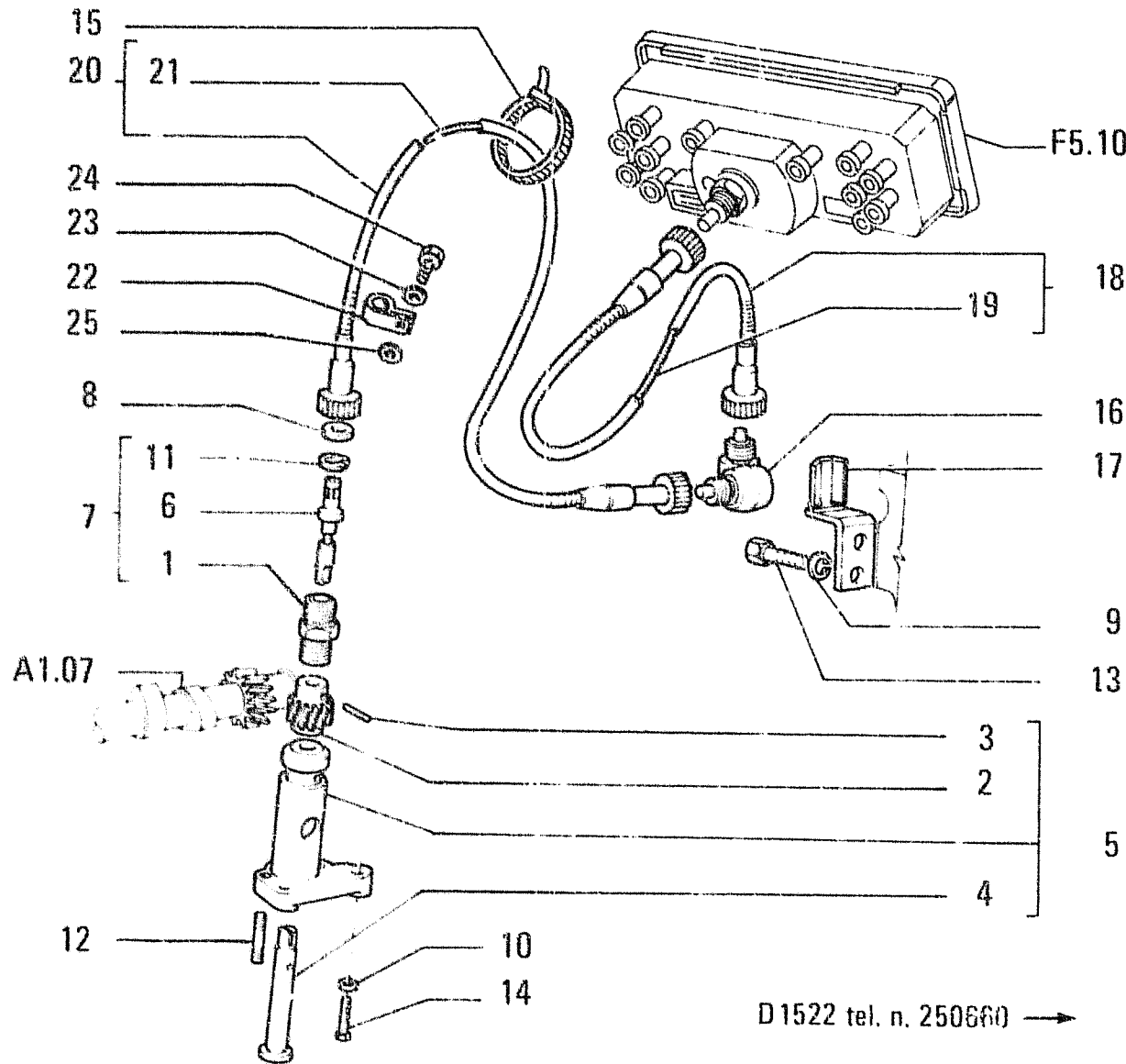

I T E M	PART NUMBER	Q T Y	TRANS CODE	DESCRIPTION	DESCRIZIONE
21	79050458	1	165T	FLEXIBLE SHAFT - INNER D1617	TRASMISSIONE FLESSIBILE - INTERNO D1617
	79052452	1	165T	FLEXIBLE SHAFT - INNER C1617	TRASMISSIONE FLESSIBILE - INTERNO C1617
22	73074679	1	231S	CLIP D1617	STAFFETTA D1617
23	70677005	1	131R	WASHER D1617	ROSETTA D1617
24	16043131	1	40V	SCREW 8x1,25x14 D1617	VITE 8x1,25x14 D1617
25	12646721	1	131R	WASHER 8,15x20 D3277	ROSETTA 8 15x20 D3277

D 1522 tel. n. 250660 →

MULTIMETER DRIVE - COMAN'DO CRONOGIROMETRO - COMMANDE D'HORO TACHYMETRE - ANTRIEB
F.STUNDENZAEHLER UND DREHZAHLMESSER - ARRASTRE DEL HOROTACÓMETRO

A1.08/A

N.T.R. 200 - 15.10.1990

604.01.081.05

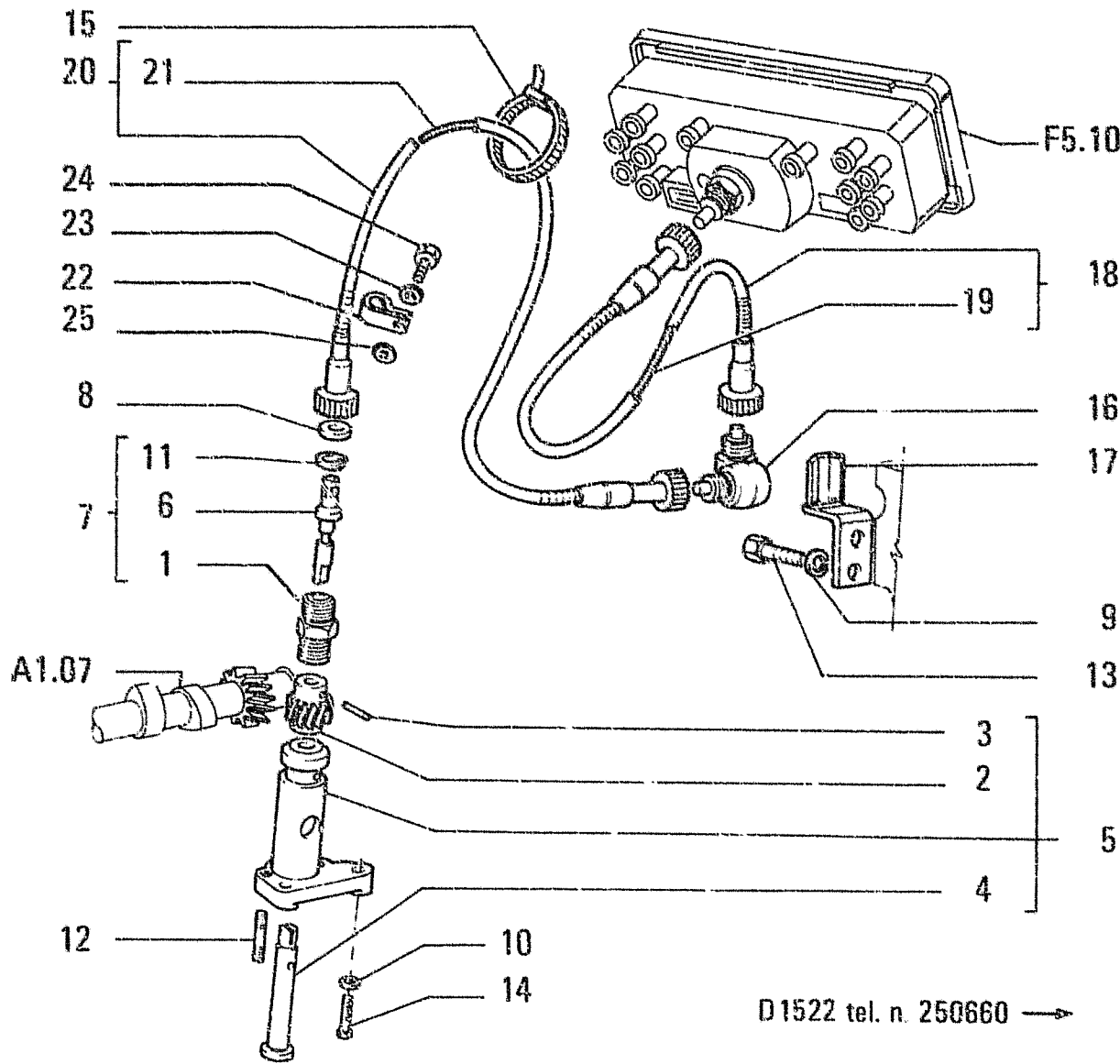

ITEM	PART NUMBER	QTY	TRANS CODE	DESCRIPTION	DESCRIZIONE
1	4589429	1	20R	FITTING	RACCORDO
2	4599726	1	50I	GEAR	INGRANAGGIO
3	4605293	1	200S	PIN	SPINA
4	4613297	1	16A	SHAFT	ALBERO
5	4617226	1	300S	SUPPORT - ASSEMBLY	SUPPORTO - COMPLETO
6	4717677	1	16A	SHAFT	ALBERO
7	4717707	1	20R	FITTING - ASSEMBLY	RACCORDO - COMPLETO
8	4998870	3	123G	SEAL ASSY	GIARNIZIONE TENUTA FRONTALE
9	10571771	2	170R	LOCKWASHER 8,1x2	ROSETTA EL. 8,1x2
10	11198071	2	170R	LOCKWASHER 8,2x15	ROSETTA EL. 8,2x15
11	13400575	1	187A	SNAP RING 9,2x10,8	ANELLO ELASTICO 9,2x10,8
12	13517311	2	210P	STUD 8x1,25x47	PRIGIONIERO 8x1,25x47
13	16043131	2	40V	SCREW 8x1,25x14	VITE 8x1,25x14
14	16043621	2	40V	SCREW 8x1,25x25	VITE 8x1,25x25
15	79013422	1	31F	CLAMP	FASCETTA
16	79048629	1	64R	MITER GEARING C1575	RINVIO ANGOLARE C1575
17	79077026	1	64R	MITER GEARING D1575	RINVIO ANGOLARE D1575
18	76012442	1	231S	CLIP D1588	STAFFETTA D1588
	79050355	1	231S	CLIP C1588	STAFFETTA C1588
19	79050459	1	165T	FLEXIBLE SHAFT - ASSEMBLY	TRASMISSIONE FLESSIBILE - COMPLETO
20	79050460	1	165T	FLEXIBLE SHAFT - INNER	TRASMISSIONE FLESSIBILE - INTERNO
	79050429	1	165T	FLEXIBLE SHAFT - ASSEMBLY D1617	TRASMISSIONE FLESSIBILE - COMPLETO D1617
	79052451	1	165T	FLEXIBLE SHAFT - ASSEMBLY C1617	TRASMISSIONE FLESSIBILE - COMPLETO C1617

MULTIMETER DRIVE - COMANDO CRONOGIROMETRO - COMMANDE D'HORO TACHYMETRE - ANTRIEB
 F.STUNDENZAEHLER UND DREHZAHLMESSER - ARRASTRE DEL HOROTACÓMETRO

A1.08/A

N.T.R. 200 - 15.10.1990

604.01.081.05

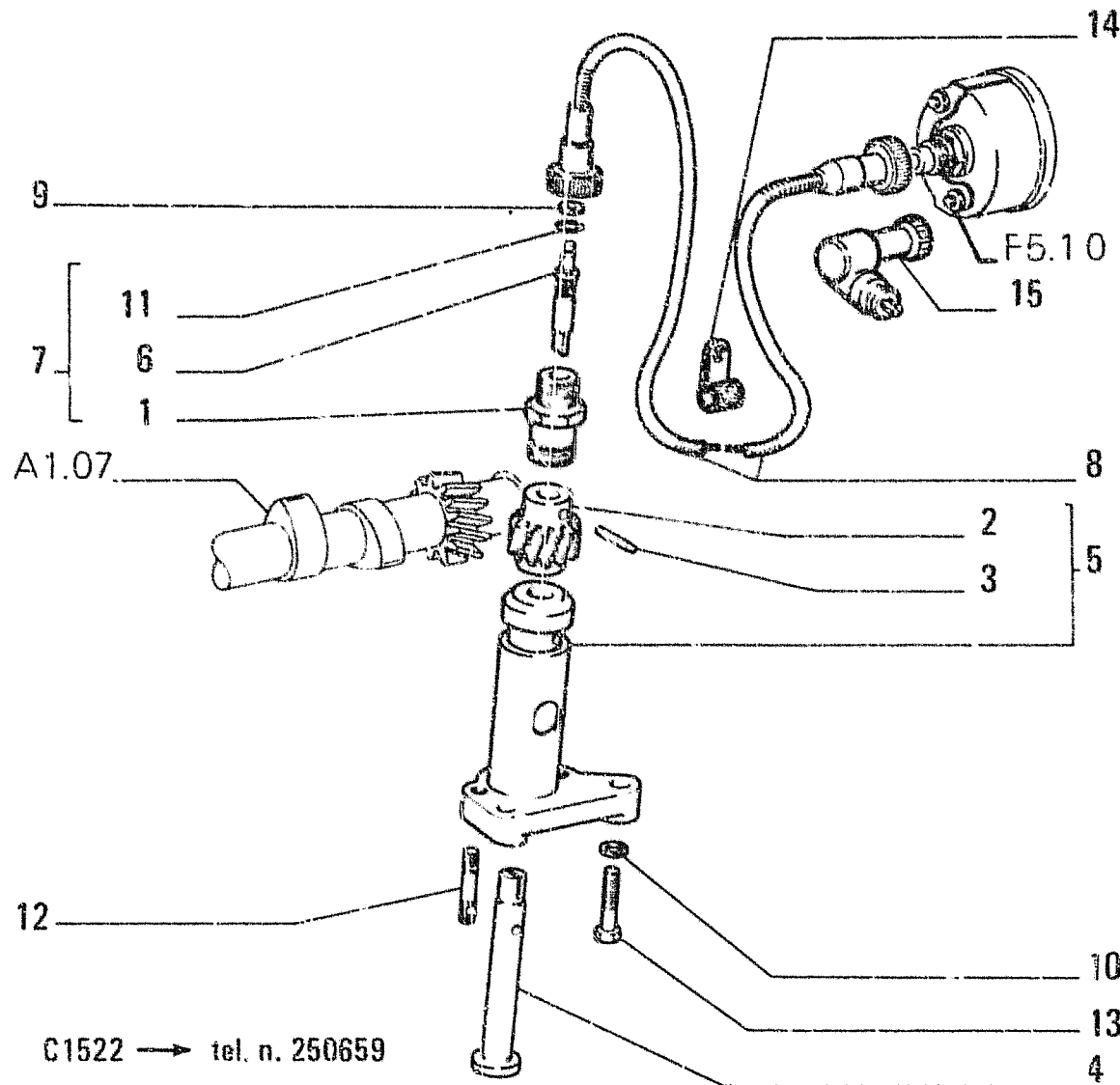

ITEM	PART NUMBER	QTY	TRANS CODE	DESCRIPTION	DESCRIZIONE
1	4589429	1	20R	FITTING	RACCORDO
2	4599726	1	50I	GEAR	INGRANAGGIO
3	4605293	1	200S	PIN	SPINA
4	4613297	1	16A	SHAFT	ALBERO
5	4617226	1	300S	SUPPORT - ASSEMBLY	SUPPORTO - COMP. ETO
6	4717677	1	16A	SHAFT	ALBERO
7	4717707	1	20R	FITTING - ASSEMBLY	RACCORDO - COMP. ETO
8	4976733	1	165T	FLEXIBLE SHAFT C1166	TRASMISSIONE FLESSIBILE C1166
	79047124	1	165T	FLEXIBLE SHAFT D1166	TRASMISSIONE FLESSIBILE D1166
9	4998870	1	123G	SEAL ASSY	GUARNIZIONE TENUTA FRONTALE
10	11198071	2	132R	LOCKWASHER 8,2x15	ROSETTA DI SICUREZZA 8,2x15
11	13400575	1	51A	LOCKRING 9,2x10,8	ANELLO DI SICUREZZA 9,2x10,8
12	13516811	2	210P	STUD 8x1,25x32	PRIGIONIERI 8x1,25x32
13	16043621	2	40V	SCREW 8x1,25x25	VITE 8x1,25x25
14	79020511	1	231S	CLIP	STAMPETTA
15	598816	1	64R	MITER GEARING D1166	INVIO ANGOLARE D1166

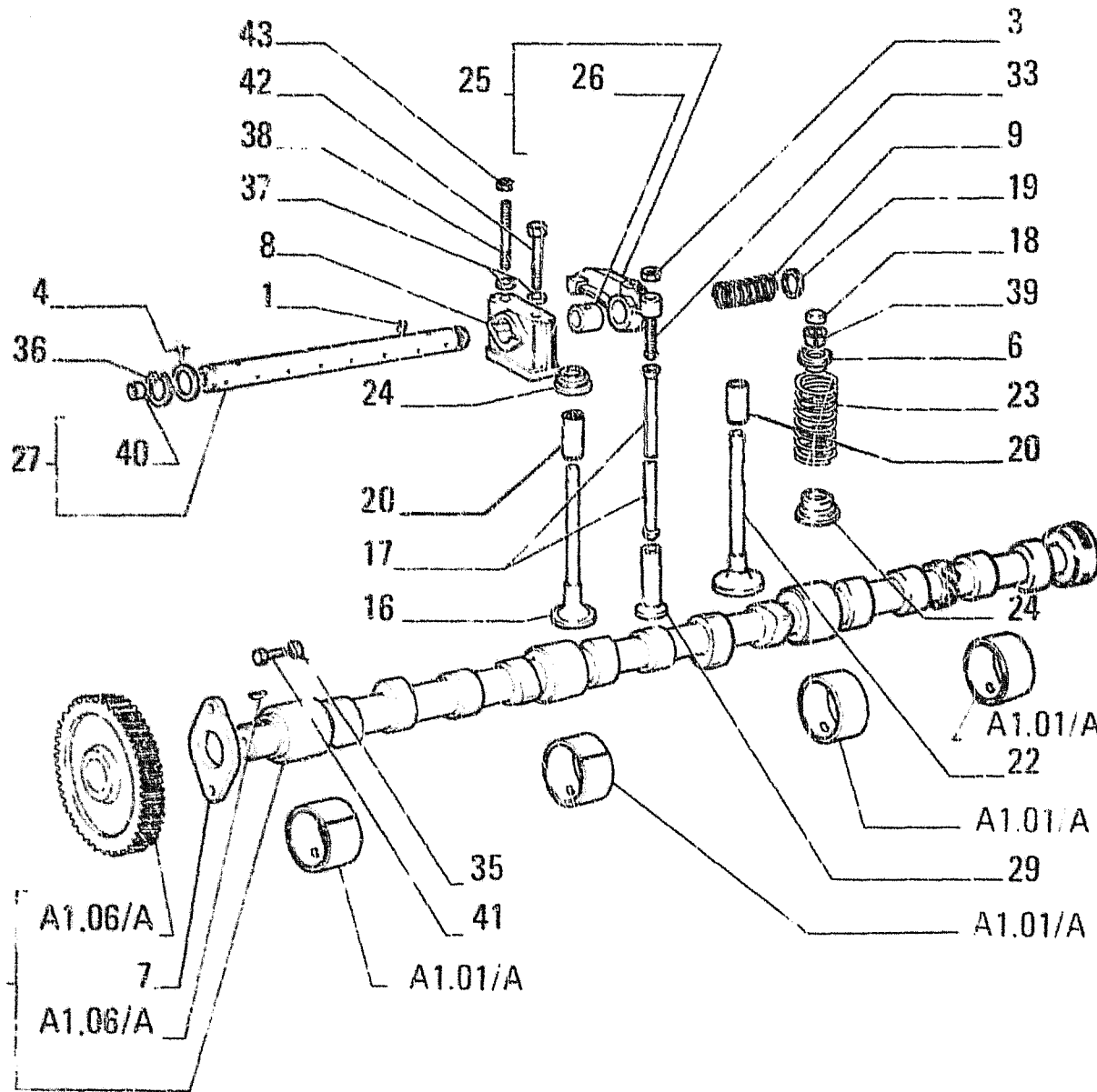

D 1572 Tel. n. 250905 →

FIAT TEMPR A FD7

A1.07/ A TAV. 1 PAG.2

ITEM	PART NUMBER	QTY	TRANS CODE	DESCRIPTION	DESCRIZIONE
29	4690507	12	240P	TAPPET +0.2	PUNTERIA +0.2
	4690503	12	240P	TAPPET +0.3	PUNTERIA +0.3
33	4699783	12	40V	SCREW	VITE
35	11193871	2	131R	WASHER 8,4x16	ROSETTA 8,4x16
36	11066675	2	51A	LOCKRING 16,5x1,2	ANILLO DI SICUREZZA 16,5x1,2
37	11198071	12	132R	LOCKWASHER 8,2x15	ROSETTA DI SICUREZZA 8,2x15
38	13516221	6	210P	STUD 8x1,25x102	PRIGIONIERO 8x1,25x102
39	14196670	24	100S	LOCK CONE 7,85x10	SEMICONO 7,85x10
40	14328301	2	50T	PLUG 12x5	TAPPO 12x5
41	16043421	2	40V	SCREW 8x1,25x20	VITE 8x1,25x20
42	16044521	6	40V	SCREW 8x1,25x65	VITE 8x1,25x65
43	16100811	1	10D	NUT 8x1,25x6,5	DADO 8x1,25x6,5

VALVE GEAR - DISTRIBUZIONE - DISTRIBUTION - STUERUNG - DISTRIBUCIÓN

A1.07/A

N.T.K. 200 - 15.10.1990

604.01.081.05

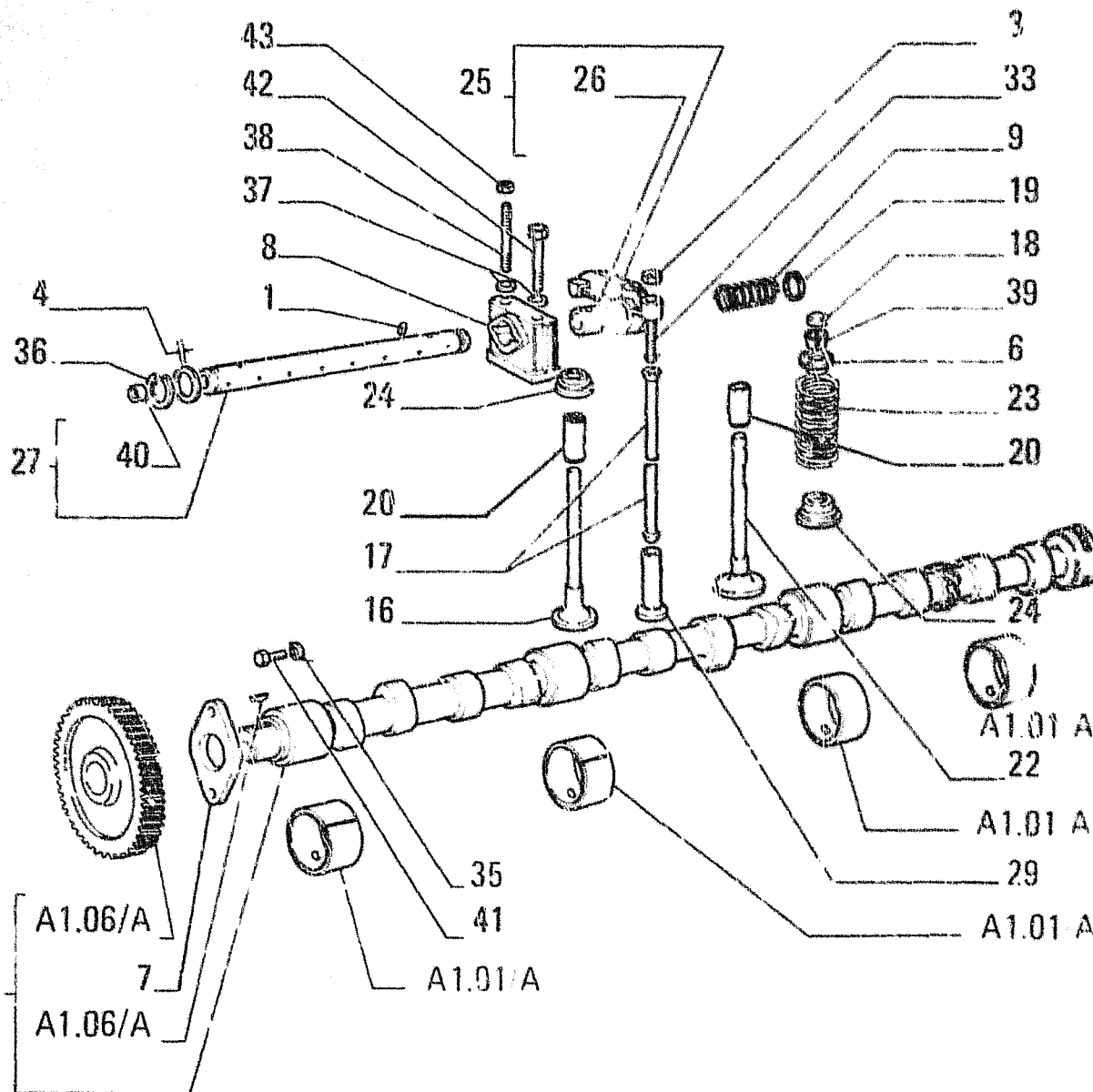

D 1572 Tel. n. 250905

FIATALLIS FD7

A1.07/ A TAV. 1 PAG.1

ITEM	PART NUMBER	QTY	TRANS CODE	DESCRIPTION	DESCRIZIONE
1	563652	1	40V	SCREW	VITE
3	4338920	12	10D	NUT	DADO
4	4570798		131R	WASHER - THICKNESS 0,7	ROSETTA - SPESSORE 0,7
	4570799		131R	WASHER - THICKNESS 0,5	ROSETTA - SPESSORE 0,5
6	4780558	12	60S	CUP - UPPER	SCODELLINO - SUPERIORE
7	459939C	1	105P	PLATE	PIASTRA
8	4601295	6	300S	SUPPORT	SUPPORTO
9	4601296	5	100M	SPRING	MOLLA
11	4786937	1	17A	CAMSHAFT - ASSEMBLY C3346	ALBERO AD ECCENTRICI - COMPLETO C3346
	4824221	1	17A	CAMSHAFT - ASSEMBLY D3346	ALBERO AD ECCENTRICI - COMPLETO D3346
16	4784889	6	112V	EXHAUST VALVE	VALVOLA SCARICO
17	4770455	12	90A	ROD	ASTA
18	4625173	12	60S	CUP	SCODELLINO
19	4639661	10	131R	WASHER - INNER THICKNESS 1	ROSETTA - INTERNO SPESSORE 1
20	4802126	12	150G	VALVE GUIDE	GUIDA DELLA VALVOLA
	4802127	12	150G	VALVE GUIDE +0,2	GUIDA DELLA VALVOLA +0,2
22	4824416	6	111V	INTAKE VALVE	VALVOLA ASPIRAZIONE
23	4780108	12	100M	SPRING	MOLLA
24	4780559	12	60S	CUP - LOWER	SCODELLINO - INFERIORE
25	4681251	12	55B	ROCKER - ASSEMBLY	BILANCIERE - COMPLETO
26	4682937	1	95B	BUSHING	BOCCOLA
27	4683070	1	16A	SHAFT - ASSEMBLY C3349	ALBERO - COMPLETO C3349
	4838844	1	16A	SHAFT - ASSEMBLY D3349	ALBERO - COMPLETO D3349
29	4690352	12	240P	TAPPET +0,0	PUNTERIA +0,0
	4690506	12	240P	TAPPET +0,1	PUNTERIA +0,1

VALVE GEAR - DISTRIBUZIONE - DISTRIBUTION - STUERUNG - DISTRIBUCIÓN

A1.07/A

N.T.R. 200 - 15.10.1990

604.01.081.05

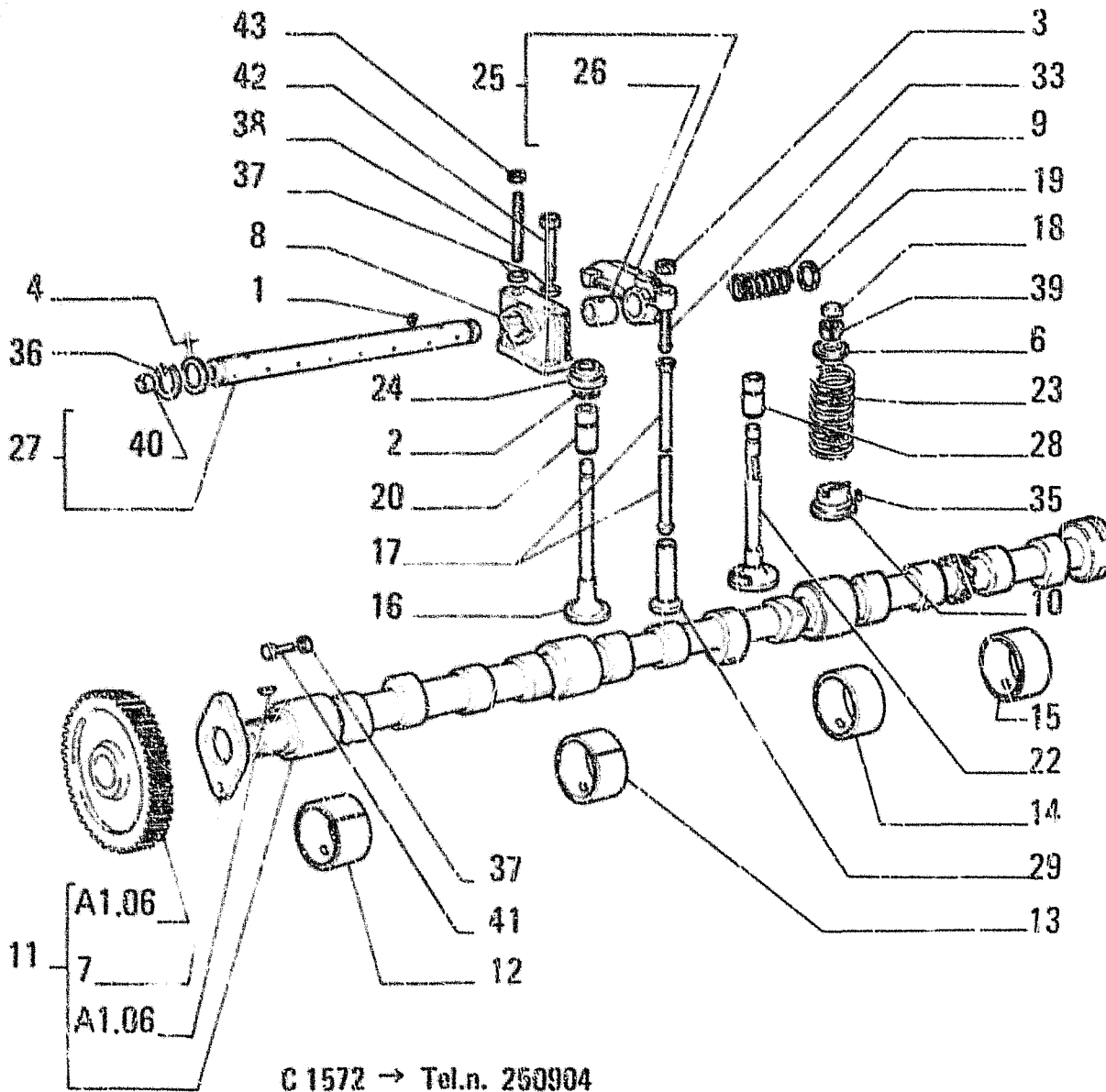

FIATALLIS FD7

A1.07 TAV. 1 PAG.2

ITEM	PART NUMBER	QTY	TRANS CODE	DESCRIPTION	DESCRIZIONE
24	4673610	6	60S	CUP - LOWER	SCODELLINO - INFERIORE
25	4681251	12	55B	ROCKER - ASSEMBLY	BILANCIERE - COMPLETO
26	4682937	1	95B	BUSHING	BOCCOLA
27	4683070	1	16A	SHAFT - ASSEMBLY	ALBERO - COMPLETO
28	4684422	6	152G	EXHAUST VALVE GUIDE	GUIDA DELLA VALVOLA DI SCARICO
29	4690352	12	240P	TAPPET +0.0	PUNTERIA +0.0
	4690506	12	240P	TAPPET 0.1	PUNTERIA 0.1
	4690507	12	240P	TAPPET +0.2	PUNTERIA +0.2
	4690508	12	240P	TAPPET +0.3	PUNTERIA +0.3
33	4699783	12	40V	SCREW	VITE
35	10329910	6	200S	PIN 3x3	SPINA 3x3
36	11066675	2	51A	LOCKRING 16.5x1.2	ANELLO DI SICUREZZA 16.5x1.2
37	11198071	14	132R	LOCKWASHER 8.2x15	ROSETTA DI SICUREZZA 8.2x15
38	13516221	6	210P	STUD 8x1.25x102	PRIGIONIERO 8x1.25x102
39	14196670	24	100S	LOCK CONE 7.85x10	SEMICONO 7.85x10
40	14328301	2	50T	PLUG 12x5	TAPPO 12x5
41	16043421	2	40V	SCREW 8x1.25x20	VITE 8x1.25x20
42	16044521	6	40V	SCREW 8x1.25x65	VITE 8x1.25x65
43	16100811	6	10D	NUT 8x1.25x6.5	DADÙ 8x1.25x6.5

VALVE GEAR - DISTRIBUZIONE - DISTRIBUTION - STEUERUNG - DISTRIBUCION

A1.07

N.T.R. 191 - 20.02.1990

604.01.081.04

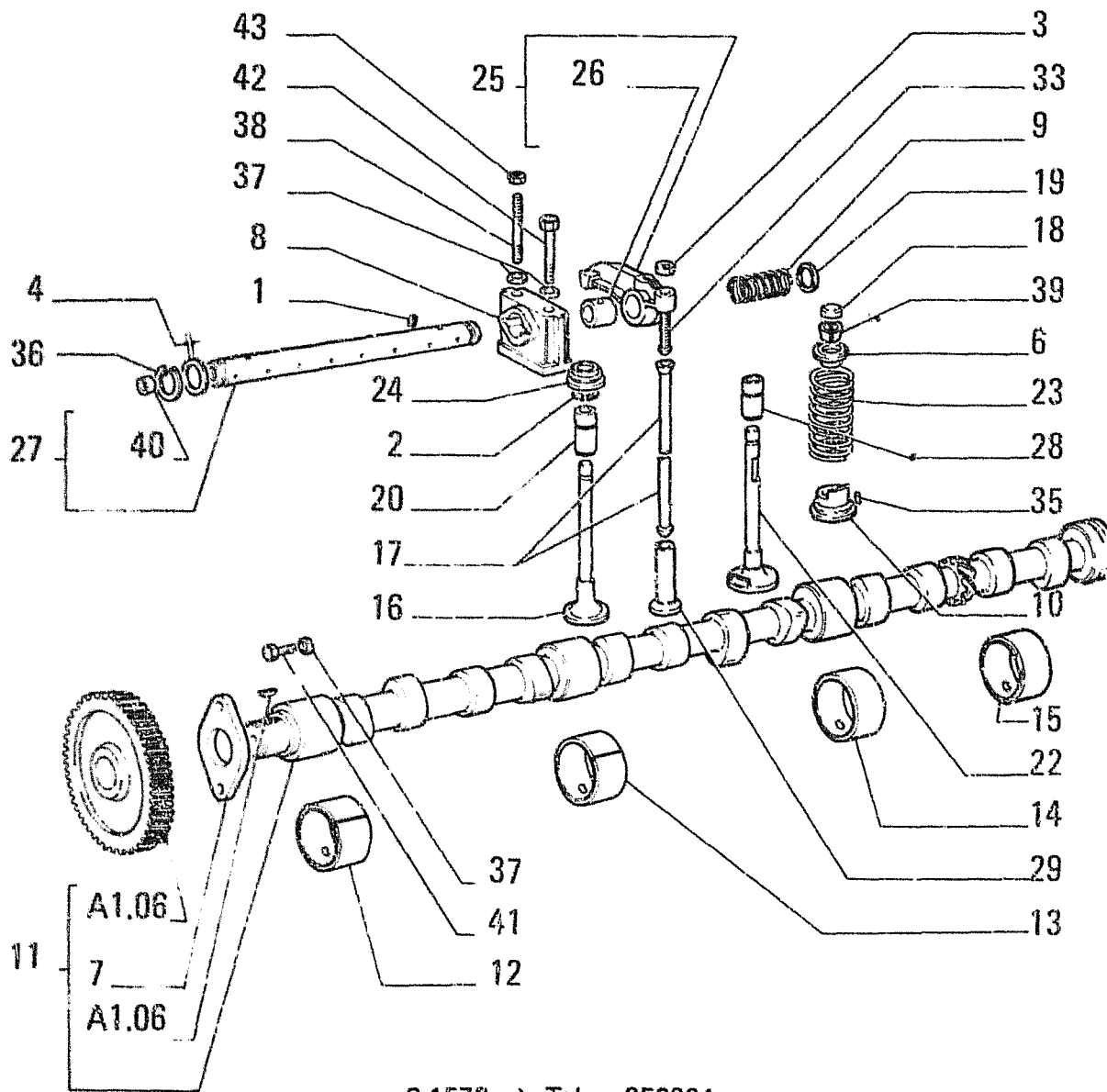

C 1572 → Tel.n. 250904

FIATALLIS FD7

A1.07 TAV. 1 PAG.1

ITEM	PART NUMBER	QTY	TRANS CODE	DESCRIPTION	DESCRIZIONE
1	563652	1	40V SCREW	VITE	
2	4231247	12	45A RING	ANELLO	
3	4338920	12	10D NUT	DADO	
4	4570798		131R WASHER - THICKNESS 0,7	ROSETTA - SPESSORE 0,7	
	4570799		131R WASHER - THICKNESS 0,5	ROSETTA - SPESSORE 0,5	
6	4578175	12	60S CUP - UPPER	SCODELLINO - SUPERIORE	
7	4599398	1	105P PLATE	PIASTRA	
8	4601295	6	300S SUPPGRT	SUPPORTO	
9	4601296	5	100M SPRING	MOLLA	
10	4601302	6	60S CL'P - LOWER	SCODELLINO - INFERIORE	
11	4603190	1	17A CAMSHAFT - ASSEMBLY	ALBERO AD ECCENTRICI - COMPLETO	
12	4603448	1	95B BUSHING - FRONT	BOCCOLA - ANTERIORE	
	4718621	1	95B BUSHING - FRONT	BOCCOLA - ANTERIORE	
13	4603449	1	95B BUSHING - FRONT	BOCCOLA - ANTERIORE	
14	4603450	1	95B BUSHING - REAR	BOCCOLA - POSTERIORE	
15	4603451	1	95B BUSHING - REAR	BOCCOLA - POSTERIORE	
16	4621511	6	111V INTAKE VALVE	VALVOLA ASPIRAZIONE	
17	4622850	12	90A ROD +0,0	ASTA +0,0	
18	4625173	12	60S CUP	SCODELLINO	
19	4639661	10	131R WASHER - INNER THICKNESS 1	ROSETTA - INTERNO SPESSORE 1	
20	4648421	6	151G INTAKE VALVE GUIDE	GUIDA DELLA VALVOLA DI ASPIRAZIONE	
	4648422	6	151G INTAKE VALVE GUIDE +0,2	GUIDA DELLA VALVOLA DI ASPIRAZIONE +0,2	
22	4673608	6	112V EXHAUST VALVE	VALVOLA SCARICO	
23	4673609	12	100M SPRING	MOLLA	

VALVE GEAR - DISTRIBUZIONE - DISTRIBUTION - STEUERUNG - DISTRIBUCION

A1.07

N.T.R. 191 - 20.02.1990

604.01.081.04

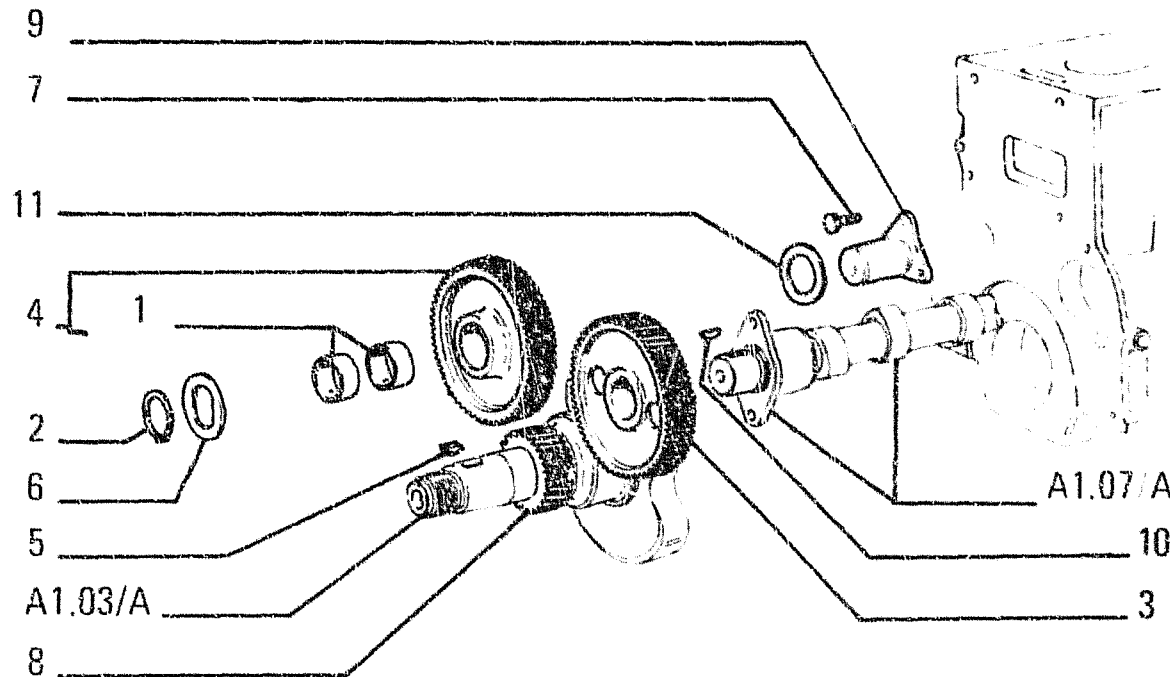

I T E M	PART NUMBER	Q T Y	TRANS CODE	DESCRIPTION	DESCRIZIONE
1	4769418	2	95B	RUSHING	BOCCOLA
2	4769420	1	51A	LOCKRING	ANELLO DI SICUREZZA
3	4769412	1	50I	GEAR	INGRANAGGIO
4	4769414	1	50I	GEAR - ASSEMBLY	INGRANAGGIO - COMPLETO
5	4655844	1	60L	KEY	LINGUETTA
6	4769419	1	131R	WASHER	ROSETTA
7	16321021	3	40V	SCREW	VITE
8	4809524	1	50I	GEAR	INGRANAGGIO
9	4769416	1	80P	PIN	PERNO
10	10205910	1	60L	KEY 9x5	LINGUETTA 9x5
11	4667452	1	131R	WASHER	ROSETTA

D 1572 Tel. n. 250905

CAMSHAFT DRIVE - COMANDO DISTRIBUZIONE - COMMANDE DE DISTRIBUTION - STEUERUNGSANTRIEB -
 PIÑONES DE LA DISTRIBUCION

A1.06/A

N.T.R. 200 - 15.10.1990

604.01.081.05

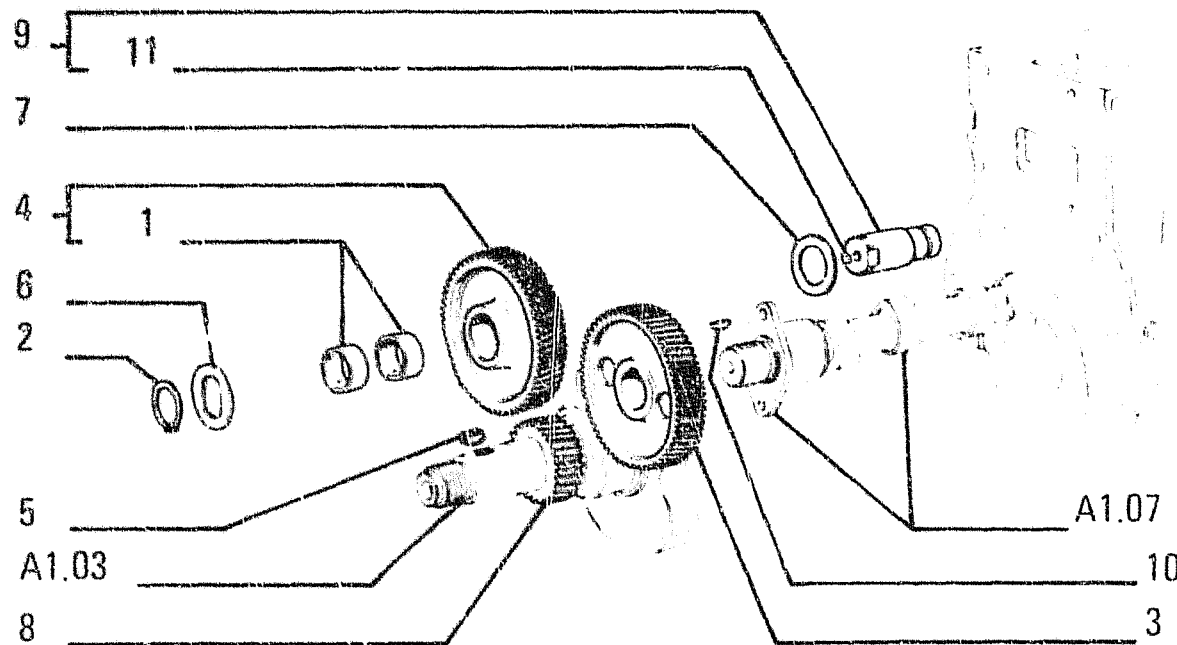

I T E M	PART NUMBER	Q T Y	TRANS CODE	DESCRIPTION	DESCRIZIONE
1	4599807	2	95B	BUSHING	BOCCOLA
2	4600329	1	51A	LOCKRING	ANELLO DI SICUREZZA
3	4607511	1	50I	GEAR	INGRANAGGIO
4	4607743	1	50I	GEAR - ASSEMBLY	INGRANAGGIO - COMPLETO
5	4655844	1	60L	KEY	LINGUETTA
6	4667450	1	131R	WASHER	ROSETTA
7	4667451	1	131R	WASHER	ROSETTA
8	4680071	1	50I	GEAR	INGRANAGGIO
9	4746023	1	80P	PIN - ASSEMBLY	PERNO - COMPLETO
10	10205910	1	60L	KEY 9x5	LINGUETTA 9x5
11	14328101	1	50T	PLUG 8x4	TAPPO 8x4

C 1572 → Tel.n. 250904

CAMSHAFT DRIVE - COMANDO DISTRIBUZIONE - COMMANDE DE DISTRIBUTION - STEUERUNGSANTRIEB -
PIÑONES DE LA DISTRIBUCION

A1.06

N.T.R. 158 - 13.03.1987

604.01.081.03

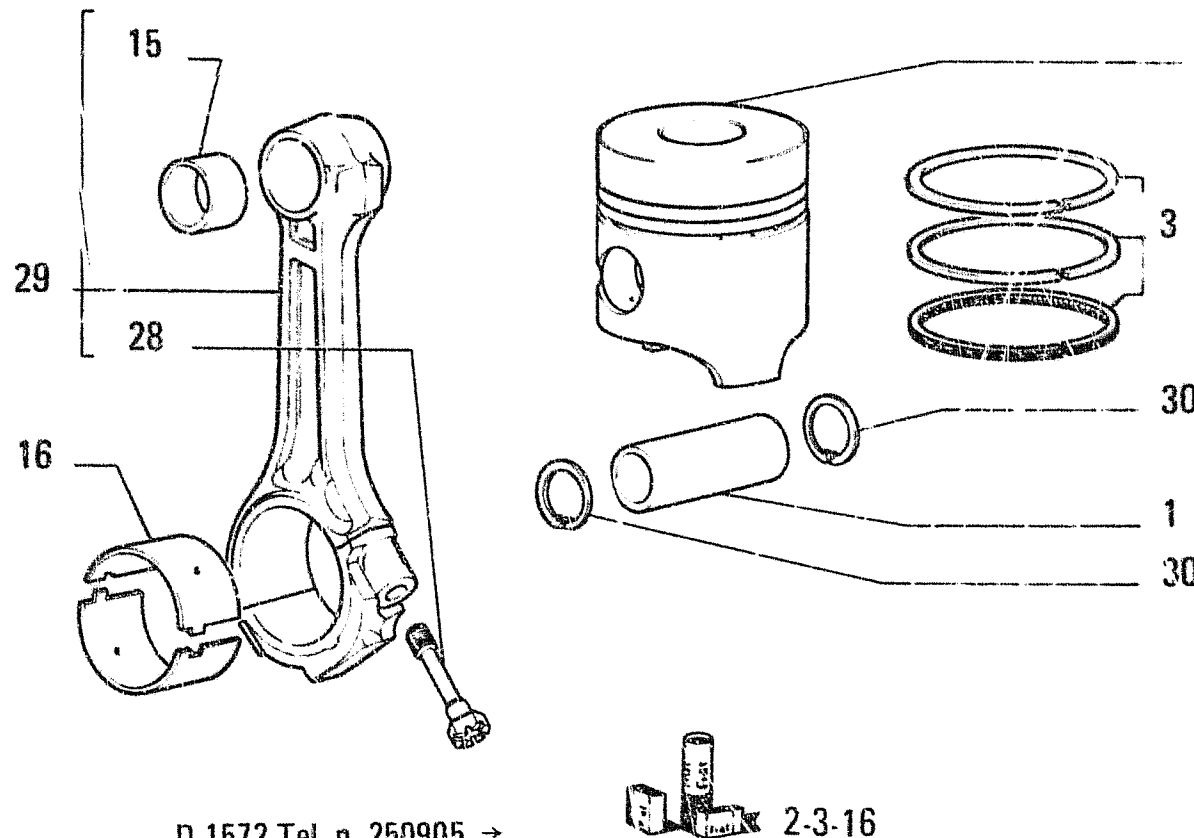

D 1572 Tel. n. 250905 →

2-3-16

ITEM	PART NUMBER	QTY	TRANS CODE	DESCRIPTION	DESCRIZIONE
1	4770651	6	80P PIN		PERNO
2	1930186	6	2K KIT STANTUFFO+0,0		KIT STANTUFFO +0,0
	1930188	6	2K KIT STANTUFFO+0,4		KIT STANTUFFO +0,4
	1930190	6	2K KIT STANTUFFO+0,8		KIT STANTUFFO +0,8
3	1930191	1	2K KIT ANELLI+0,0		KIT ANELLI+0,0
	1930193	1	2K KIT ANELLI+0,4		KIT ANELLI+0,4
	1930195	1	2K KIT ANELLI+0,8		KIT ANELLI+0,8
15	4766404	1	95B BUSHING		BOCCOLA
16	1930181	6	2K KIT SEMICUSCINETTI-0,000		KIT SEMICUSCINETTI-0,000
	1930182	6	2K KIT SEMICUSCINETTI-0,254		KIT SEMICUSCINETTI-0,254
	1930183	6	2K KIT SEMICUSCINETTI-0,508		KIT SEMICUSCINETTI-0,508
	1930184	6	2K KIT SEMICUSCINETTI-0,762		KIT SEMICUSCINETTI-0,762
	1930185	6	2K KIT SEMICUSCINETTI-1,016		KIT SEMICUSCINETTI-1,016
28	4780627	2	40V SCREW		VITE
29	4780624	6	50B LINK - ASSEMBLY		BIELLA COMPLETO
30	4770452	12	51A LOCKING		ANELLO DI SICUREZZA

CONNECTING RODS AND PISTONS - BIELLE E STANTUFFI - BIELLES ET PISTONS -
 PLEULSTANGEN UND KOLBEN - BIELAS Y ÉMBOLOS

A1.05/A

N.T.R. 205 - 30.09.1991
 604.01.081.06

	DESIGNAZIONE BASE	BASIC DESIGNATION	DESIGNATIONS-BASES	GRUNDBEZEICHNUNGEN	DE NOMINACIONES BASE
111V	VALVOLA ASPIRAZIONE	INTAKE VALVE	SOUPAPE DE ADMISSION	EINLASSVENTIL	VALVULA DE ASPIRACION
111B	BRACCIO ABBATTIMENTO (AD)		BRAS ABATTAGE (AD)	ABBRUCHARM (AD)	
1119	BRACCIO ABBATTIMENTO (BD)		BRAS ABATTAGE (BD)	ABBRUCHARM (BD)	
112C	CAVO MASSA	GROUND CABLE	FIL DE MAS	MASSEKABEL	CABLE DE MASA
112F	FUSO A SNODO	STEERING KNUCKLE	FUSEE	ACHSSCHENKEL	PUNTA DE EJE
112P	PIASTRINA ISOLANTE	INSULATING PLATE	PLAQUETTE ISOLANTE	ISOLIERUNG	PLACA AISLANTE
112S	SEPARATORE D'ARIA E VAPORE	AIR AND STEAM SEGREGATOR	SEPARATEUR D'AIR ET DE VAPEUR	LUFT-UND DAMPFAB- SCHEIDER	SEPARADOR DE AIRE Y VAPOR
112S					
112V	VALVOLA SCARICO	EXHAUST VALVE	SOUPAPE D'ECHAPPEMENT	AUSLASSVENTIL	VALVULA DE DESCARGA
1120	PIASTRA DI SPINTA PER AD		PLAQUE DE POUSSEE POUR AD	SCHUBPLATTE (AD)	
1124	TILT IDRAULICO (HA)	HYDRAULIC TILT (HA)	TILT HYDRAULIQUE (HA)	HYDR TILTVERSTELLUNG (HA)	TILT IDRAULICO (HA)
112B	TILT-PITCH (HA)	TILT-PITCH (HA)	TILT-PITCH (HA)	TILT-PITCH (HA)	
113B	BOZZELLO CARRUCOLA	SHEAVE BLOCK	POULIE	FLASCHENZUG	GARRUCHA
113F	FUSO	STUB SHAFT	FUSEE	ACHSSCHENKEL	MANGUETA
113G	GUANTI	GLOVES	GANTS	HANDSCHUHE	GUANTES
113M	MONOLEVA	SINGLE LEVER	LEVIER UNIQUE	EINHEBELBEDIENUNG	MONOPALANCA
113P	PIASTRINA DI SICUREZZA	LOCKPLATE	PLAQUETTE FREIN	SICHERUNGSBLECH	CHAPITA DE SEGURIDAD
113S	SERBATOIO OLIO	OIL RESERVOIR	RESERVOIR D'HUILE	GELTANK	DEPOSITO ACEITE
113T	TESTA CILINDRI	CYLINDER HEAD	CULASSE DE CYLINDRE	ZYLINDERKOPF	TAPA DE CILINDROS
113V	VALVOLA DI ANTICIPO	ADVANCE VALVE	SOUPAPE D'AVANCE	REGELVENTIL	VALVULA DE AVANCE
1130	ATTACCO RAPIDO				
113S	PIASTRA DI SPINTA PER BD		PLAQUE DE POUSSEE POUR BD	SCHUBPLATTE (BD)	
1139	TILT-PITCH	TILT-PITCH	TILT-PITCH	TILT-PITCH	
114P	PIASTRINA DI COMANDO	DRIVE LINK	PLAQUE DE COMMANDE	MITNEHMER	PLACA DE ARRASTRE
114S	SERBATOIO COMBUSTIBILE	FUEL TANK	RESERVOIR DE COMBUSTIBLE	KRAFTSTOFFTANK	TANQUE COMBUSTIBLE
115G	GUARDONE PER BENNA	SPILL GUARD	REHAUSSE DE GODET	SCHAUFEL-AUFSATZWAND	PLACA DE EXTENSION DEL CUCHARON
115G					
115M	MONTANTE	PILLAR	MONTANTE	SAEULE	MONTANTE
115S	SERBATOIO	TANK	RESERVOIR	TANK	DEPOSITO
115M	MONTATOIO	STEP PLATE	MARCHEPIED	TRITTBLECH	ESTRIBO
116R	RIVESTIMENTO	COVERING	RETEMENT	VERKLEIDUNG	REVESTIMIENTO
116S	SERBATOIO CON VALVOLE	RESERVOIR W/VALVE	RESERVOIR ET SOL- PAPES	BEHAELTER M. VENTIL	DEPOSITO CON VAL- VULAS
116S					
116T	TESTA DEL GIUNTO SFERICO	SOCKET	JOINT A ROTULE	KUGELPFANNE	ARTICULACION DE ROTULA
116T					
1160	BLOCCAGGIO BRACCI	BOOM LOCK	BLOCAGE BRAS	HUBARMARRETIERUNG	ANCLAJE DE BRAZO
1161	BLOCCAGGIO BENNA	BUCKET LOCK	BLOCAGE DU GODET	SCHAUFELARRETIERUNG	ANCLAJE DE LA CUCHARA
117R	RIVESTIMENTO ISOLANTE	INSULATION	RETEMENT ISOLANT	ISOLIERUNG	FORRO AISLANTE
117S	SERBATOIO A DEPRESSIONE	VACUUM TANK	RESERVOIR DEPRES- SEUR	UNTERDRUCKBEHAEL- TER	DEPOSITO DE VACIO
117S					

DESIGNAZIONE BASE	BASIC DESIGNATION	DESIGNATIONS-BASES	GRUNDBEZEICHNUNGEN	DENOMINACIONES BASE	
1170	INDICATORE POSIZIONE BENNA	BUCKET LEVEL INDICATOR	MISE A NIVEAU DU GODET	SCHAUFELSTELLUNGSANZEIGER	NIVELACION DE LA CUCHARA
1171	POSIZIONATORE AUTOMATICO BENNA	BUCKET LEVELER	MISE A NIVEAU AUTOMAT. GODET	AUTOMAT SCHAUFEL-RUECKSTELLUNG	NIVELACION AUTOMATICA CUCHARA
118P	PIASTRINA MAGNETICA	MAGNETIC PLAQUE	PLAQUETTE MAGNETI-	MAGNETBLECH	IMAN
118P			QUE		
118S	SERRAFILO	TERMINAL SCREW	SERRE-FIL	ANSCHLUSSKLEMME	BORNE
1181	DISPOSITIVO KICK-OUT	BOOM KICK-OUT	ARRET AUTOMATIQUE BRAS	AUTOMAT HUBAB-SCHALTUNG	LIMITE AUTOMATICO DEL BRAZO
119M	MORSETTIERA	CONNECTION BLOCK	PLAQUE DE JONCTION	KLEMMLEISTE	CAJA DE CONTACTOS
119T	TESTA	HEAD	TETE	KOPF	CABEZA
120A	AUTOPILOTA	AUTOPILOT	AUTOPILOTE	SCHALTSTEUERGRUPPE	AUTOPILOTO
120R	BOTTONE	BUTTON	BOUTON	KNOPF	BOTON
120G	GUARNIZIONE MANA	GASKET	JOINT	FLACHDICHTUNG	GUARNICION
120M	MORSETTO ELETTRICO	TERMINAL CONNECTOR	BORNE	KABELKLEMME	AGARRADERA
120P	PIATTELLO	PLATE	COUPELLE	TELLERSCHNIBE	PLATILLO
120R	ROCCHETTO	REEL	BOBINE	ZUENDSPULE	BOBINA
120S	SERRATURA	LOCK	SERRURE	SCHLOSS	CERRADURA
120T	TESTA DI REGISTRO	ADJUSTING SLEEVE	EMBOUT DE REGLAGE	EINSTELLBUECHSE	TUERCA DE REGLAJE
1200	BRACCI CARICATORE LUNGI	LONG BOOM	BRAS LONG	LANGER LADEARM	
121B	BOTTONE DI GOMMA	RUBBER STUD	BOUTON CAOUTCHOUC	GUMMIBOLZEN	PITON DE CAUCHO
121C	CHIUSURA LAMPO	SLIDE FASTENER	FERMETURE ECLAIR	REISSVERSCHLUSS	CIERRE DE CREMA-
121C					LLERA
121M	MORSETTO A MANO	HAND VICE	ETAU A MAIN	KLEMMBACKE	TORNILLO DE MANO
121P	PIATTELLO DELLA PUNTERIA	TAPPET PLATE	PASTILLE DE	DISTANZSCHEIBE	PLATILLO DE EMPU
121P			POUSSOIR		
121S	SEPARATORE DI CONDENSA	WATER SEGREGATOR	SEPARATEUR D'EAU	KONDENSWASSER-	SEPARADOR DE AGUA
121S			CONDENSEE	ABSCHIEDER	
122F	FINO AL MOTORE IDRAULICO ...	UP TO HYDRAULIC MOTOR...	JUSQU'AU MOTEUR HYDRAULIQUE	BIS HYDRAULIKMOTOR	HASTA EL MOTOR HIDRAULICO
122G	GUARNIZIONE	SEAL	GARNITURE	DICHTUNG	GUARNICION
122P	PIGNONE	PINION	PIGNON	RITZEL	PINON
123F	FINO AL RIDUTTORE...	UP TO REDUCTION GEAR...	JUSQU'AU REDUCTEUR	BIS UNTERSETZUNGSGETRIEBE	HASTA EL REDUCTOR
123G	GUARNIZIONE TENUTA FRONTALE	SEAL ASSY	GARNITURE FRONTAL	LIFE TIME-DICHTUNG	SELLO
123P	PIGNONE CONICO	BEVEL PINION	PIGNON CONIQUE	KEGELRITZEL	PINON CONICO
123S	SERVOCOMANDO	SERVO-CONTROL	SERVO-COMMANDE	SERVOSTEUERUNG	SERVOMANDO
124B	BRACCIOLO SEDILE	ARMREST	ACCOUDOIR DE SIEGE	ARMLEHNE	APOYABRAZO
124F	FINO AL ...	UP TO ...	JUSQU'AU...	BIS ...	HASTA EL ...
124M	MOTOPOMPA	MOTOR PUMP	POMPE A MOTEUR	PUMPENAGGREGAT	BOMBA DE MOTOR
124P	PINZA AUTOCENTRANTE	COLLET	PINCE FENDUE	SPANNZANGE	PASADOR DE MUELLE
124S	SERVODISTRIBUTORE	SERVO-VALVE	SERVO-DISTRIBUTEUR	VORSTEUERVENTIL	SERVOVALVULA
125F	FORCA	FORK			
125P	PINZA	PLIERS	PINCES	ZANGE	ALICATES
125S	SERVOFRENO	BRAKE BOOSTER	SERVO-FREIN	SERVOBREMSE	SERVOFRENO

DESIGNAZIONE BASE	BASIC DESIGNATION	DESIGNATIONS-BASES	GRUNDBEZEICHNUNGEN	DENOMINACIONES BASE
126F	FINO ALLA POMPA ...	UP TO PUMP ...	JUSQUA LA POMPE	HASTA LA BOMBA
126P	PINZA FRENO	CALIPER	ETRIER DE FREIN	ZAPATA DE FRENO
126S	SERVOFRIZIONE	CLUTCH-SERVO	SERVO-EMBRAYAGE	SERVOEMBRAGUE
127M	MOTORE IDRAULICO	HYDRAULIC MOTOR	MOTEUR HYDRAULIQUE	MOTOR HIDRAULICO
127P	PIOMBINO	LEAD SEAL	PLOMB	PRECINTO
127S	SERVOFRENO PNEUMO-IDRAULICO	AIR-HYDRAULIC ASSISTED BRAKE	SERVO-FREIN HYDRO-PNEUMATIQUE	SERVOFRENO NEUMO-HIDRAULICO
127S				
1279	TUBAZ E COMANDO ATTREZZO ANT	FRONT ATTACH PIPING AND CONTR	TUYAUTERIE ET C DE OUTIL AV	
1280	TUBAZIONI POST (DAL DEVIATORE)	REAR PIPE (FROM DIVERTER VALV)		
1281	TUBAZIONI POST (DAL DISTRIB)	REAR PIPE (FROM CONTROL VALVE)		
1288	TUBAZIONI ATTREZZO ANT	FRONT ATTACHEMENT PIPING	CONDUITES D'OUTIL AVANT	TUBERIA DEL UTIL ANTERIOR
129P	PISTA	RACE	PISTE	PISTA
130B	BRACCIO	ARM	BRAS	BRAZO
130C	CENTRALINA	CONTROL UNIT	DISPOSITIVE DE COMMANDE	CENTRAL
130F	FUNZIONE IDRAUL.SUPPL	ADDITIONAL HYDRAULIC FUNCTION		
130M	MOTORE TERMICO	ENGINE	MOTEUR	MOTOR
130P	PISTONCINO	PLUNGER	PISTON	EMBOLO DE VALVULA
130S	SERVOSTERZO	SERVOSTEERING	SERVODIRECTION	SERVODIRECCION
130T	TESTATA	END PLATE	CULASSE	TAPA
131F	FIRE SLEEVE	FIRE SLEEVE		
131R	ROSETTA	WASHER	RONDILLE	ARANDELA
131T	TESTATA CASSONE	END GATES	HAYON	TESTERO
132B	BRACCIO OSCILLANTE	SWINGING ARM	BALANCIER	BRAZO OSCILANTE
132F	FONDELLO ANT	HEAD	BOUT AVANT	TAPA ANTERIOR
132P	PISTONE	PISTON	PISTON	EMBOLO
132R	ROSETTA DI SICUREZZA	LOCKWASHER	RONDILLE FREIN	ARANDELA DE FRENO
132S	SENSORE	INDUCTIVE PROXIMITY SWITCHES	CAPTEUR	SENSORIO
133B	BRACCIO SOLLEVAMENTO	LIFT BOOM	BRAS DE LEVAGE	BRAZO LEVANTAMIENTO
133F	FORNELLO POST	BOTTOM	BOUT ARRIERE	TAPA POSTERIOR
133M	MOTORINO AVVIAMENTO	STARTER MOTOR	DEMARREUR	MOTOR DE ARRANQUE
133R	ROSETTA DI TENUTA	SEAL	JOINT D ETANCHEITE	JUNTA HERMETICA
134M	MOTORINO	MOTOR	MOTEUR	MOTOR
135C	CERCHIO RUOTA	RIM	JANTE	LLANTA
135M	MOZZO	HUB	MOYEU	CUBO
135P	PLAFONIERA	CEILING LAMP	PLAFONNIER	PANTALLA
135S	SETTORE DENTATO	TOOTHED SECTOR	SECTEUR DENTEE	SECTOR RUEDA DENTADA
136S	SETTORE RUOTA MOTRICE	SPROCKET SECTOR	SECTEUR BARBOTIN MOTEUR	SECTOR RUEDA MOTRIZ
137M	MOTORINO ELETTRICO	ELECTRIC MOTOR	MOTEUR ELECTRIQUE	MOTOR ELECTRICO
138S	SETTORE DI RIFERIMENTO	REFERENCE SECTOR	SECTEUR DE REFERENCE	PLACA DE REFERENCIAS
138S				

A

ENGINE • MOTORE • MOTEUR • MOTOR • MOTOR

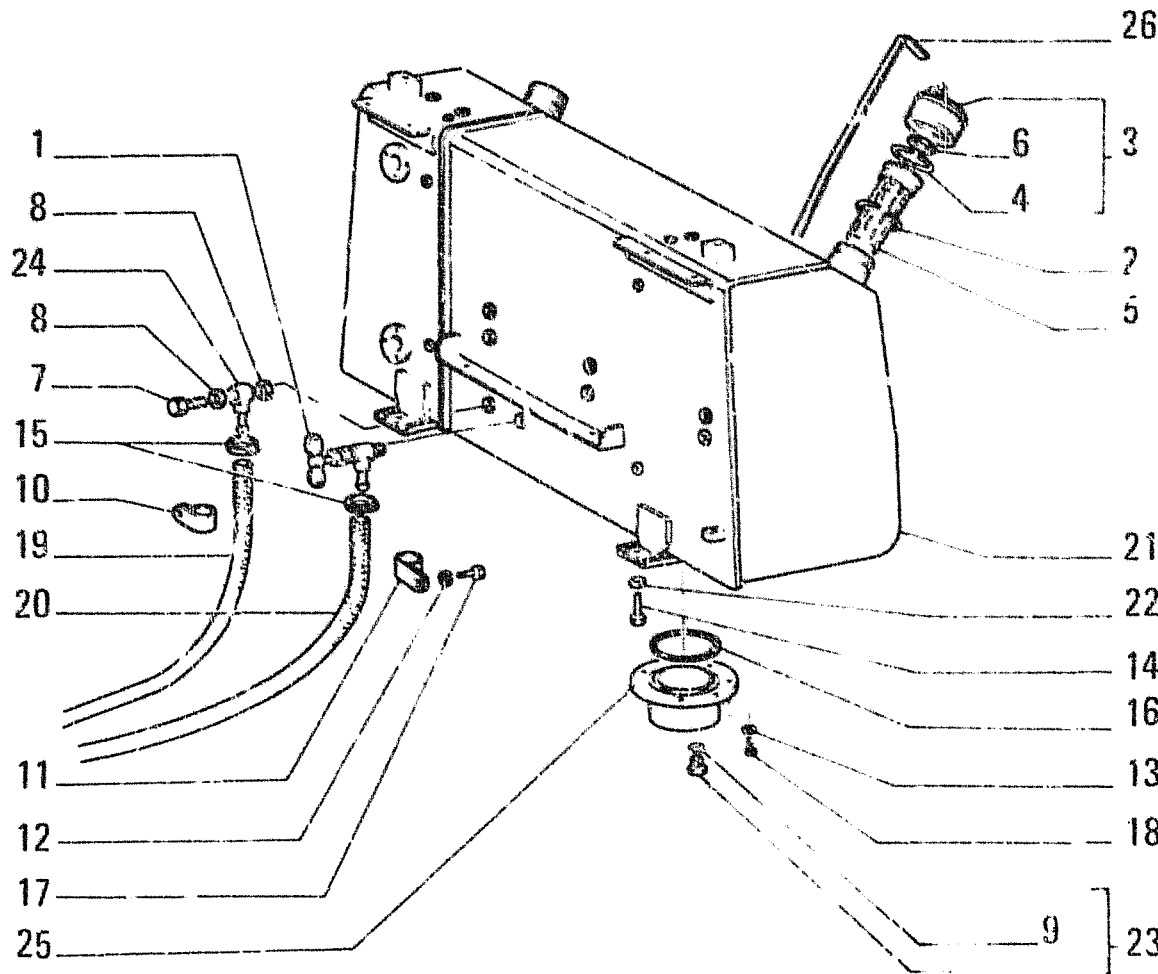

I T E M	PART NUMBER	Q T Y	TRANS CODE	DESCRIPTION	DESCRIZIONE
19	76014545				D2875
20	19053382	L	285T	HOSE 10x15 C2875	TUBO FLESSIBILE 10x15 C2875
	76014544	L	285T	HOSE 2,600M D2875	TUBO FLESSIBILE 2,600M D2875
		L	285T	HOSE 2,600M C2917	TUBO FLESSIBILE 2,600M C2917
	76014890	L	285T	HOSE 2,600M D2917	TUBO FLESSIBILE 2,600M D2917
21	76005090	1	115S	TANK C2907	SERBATOIO C2907
	76015654	1	115S	TANK D2907	SERBATOIO D2907
22	79005242	8	131R	WASHER	ROSETTA
23	10119440	1	56T	DRAIN PLUG - ASSEMBLY 18x1,5x12 D2907	TAPPO DI SCARICO - COMPLETO 18x1,5x12 D2907
	79007135	1	56T	DRAIN PLUG C2907	TAPPO DI SCARICO C2907
24	79010217	1	20R	FITTING	RACCORDO
25	76015664	1	265C	COVER D2907	COPERCHIO D2907
	79032036	1	265C	COVER - OUTER C2907	COPERCHIO - ESTERNO C2907
26	79037005	1	91A	DIPSTICK	ASTA LIVELLO

FUEL TANK AND LINES - SERBATOIO COMBUSTIBILE E TUBAZIONI - RESERVOIR ET CANALISATIONS
COMBUSTIBLE - KRAFTSTOFFTANK UND LEITUNGEN - DEPÓSITO DE COMBUSTIBLE Y TUBERÍAS

A2.01

N.T.R. 205 - 30.09.1991
604.01.081.06

C1510 → tel. n. 250904

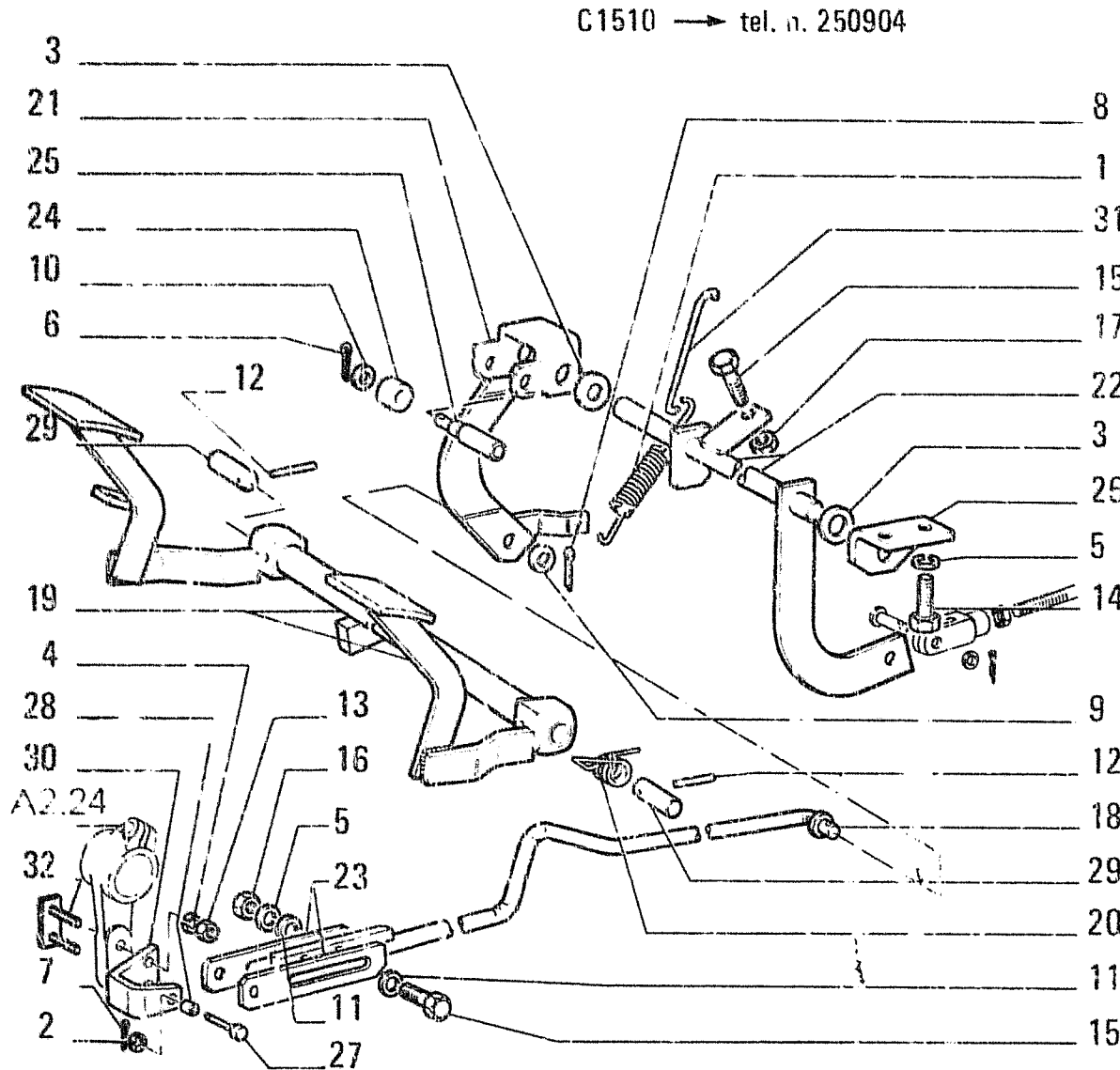

ITEM	PART NUMBER	QTY	TRANS CODE	DESCRIPTION	DESCRIZIONE
1	4967635	1	100M	SPRING	MOLLA
2	10519221	1	131R	WASHER 4,45x9	ROSETTA 4,45x9
3	10520121	2	131R	WASHER 14,4x26	ROSETTA 14,4x26
4	10571471	2	132R	LOCKWASHER 5,1x1,2	ROSETTA DI SICUREZZA 5,1x1,2
5	10571771	4	132R	LOCKWASHER 8,1x2	ROSETTA DI SICUREZZA 8,1x2
6	10734201	1	270C	COTTER PIN 1,7x18,5	COPIGLIA 1,7x18,5
7	10795001	1	270C	COTTER PIN 1,3x13,7	COPIGLIA 1,3x13,7
8	10796401	1	270C	COTTER PIN 2,7x27,6	COPIGLIA 2,7x27,6
9	12638621	1	131R	WASHER 10,2x18	ROSETTA 10,2x18
10	12642701	1	131R	WASHER 8,15x12	ROSETTA 8,15x12
11	12649721	4	131R	WASHER 8,15x20	ROSETTA 8,15x20
12	14163270	2	20ES	PIN 4,4x26	SPINA 4,4x26
13	15896421	2	10U	NUT 5x0,8x4	DADO 5x0,8x4
14	16043231	2	40V	SCREW 8x1,25x16	VITE 8x1,25x16
15	16043831	3	40V	SCREW 8x1,25x30	VITE 8x1,25x30
16	16100821	2	10U	NUT 8x1,25x6,5	DADO 8x1,25x6,5
17	16102321	1	10U	NUT 8x1,25x5	DADO 8x1,25x5
18	79031279	1	142T	TIEROD - FRONT	TIRANTE - ANTERIORE
19	79036919	1	60P	PEDAL	PEDALE
20	79034241	1	100M	SPRING	MOLLA
21	79034242	1	45L	LEVER - FRONT	LEVA - ANTERIORE
22	79034246	1	16A	SHAFT	ALBERO
23	79034254	2	110P	PLAQUE	PIASTRINA
24	79034255	1	157R	ROLLER	RULLO
25	79034256	1	80P	PIN	PERNO
26	79034258	1	80M	BRACKET	MENSOLA
27	79034988	1	93P	PIN - FRONT	PERNO - ANTERIORE

THROTTLE CONTROL LINKAGE - COMANDI ACCELERATORE - COMMANDES D'ACCELERATEUR -
 GASREGULIERUNG - MANDOS DEL ACELERADOR

2

A2.21

1

L3

N.T.R. 152 - 28.11.1986
 604.01.C91.02

C1510 → tel. n. 250904

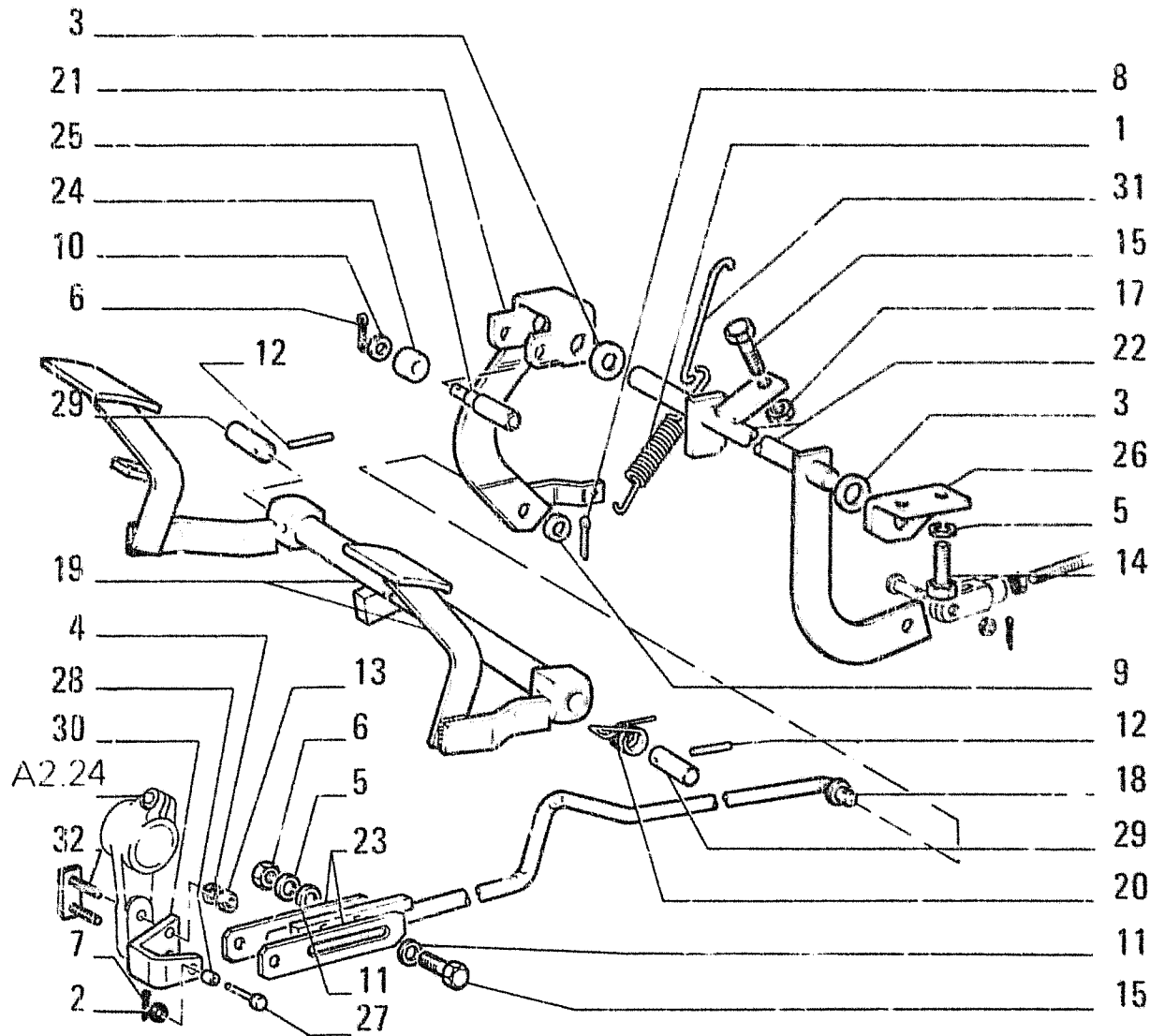

ITEM	PART NUMBER	QTY	TRANS CODE	DESCRIPTION	DESCRIZIONE
28	79034989	1	157R	ROLLER - FRONT	RULLO - ANTERIORE
29	79035034	2	80P	PIN	PERNO
30	79036912	1	100C	RETAINER	CAVALLOTTI/
31	79036913	1	30G	HOOK	GANCIO
32	79036915	1	110P	PLAQUE	PIASTRINA

THROTTLE CONTROL LINKAGE - COMANDI ACCELERATORE - COMMANDES D'ACCELERATEUR - 2
 GASREGULIERUNG - MANDOS DEL ACELERADOR

A2.21 1

N.T.R. 152 - 28.11.1986
 604.01.081.02

L4

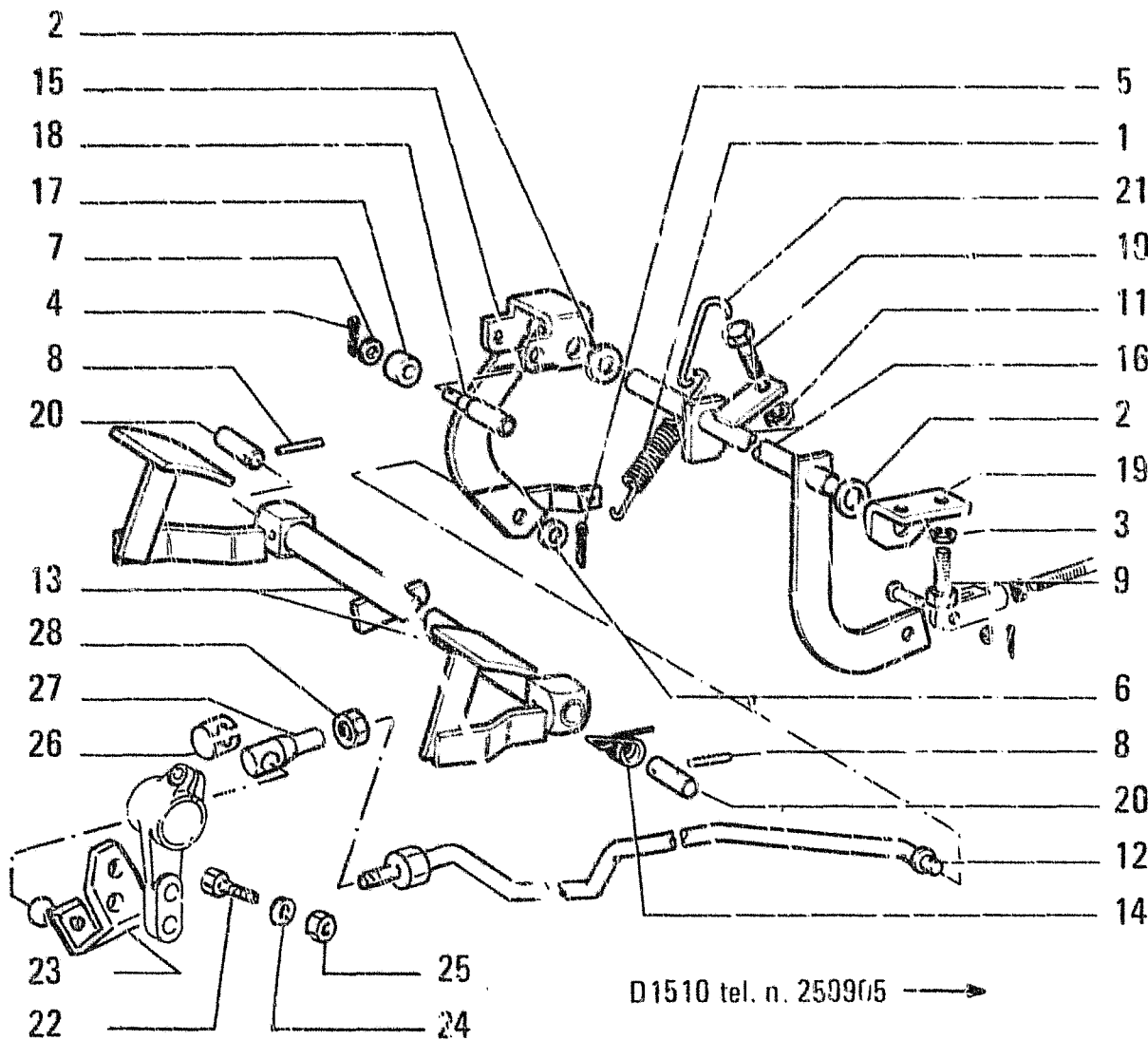

ITEM	PART NUMBER	QTY	TRANS CODE	DESCRIPTION	DESCRIZIONE
1	4967635	1	100M	SPRING	MOLLA
2	10520121	2	131R	WASHER 14,4x26	ROSETTA 14,4x26
3	10571771	2	132R	LOCKWASHER 8,1x2	ROSETTA DI SICUREZZA 8,1x2
4	10734201	1	270C	COTTER PIN 1,7x18,5	COPIGLIA 1,7x18,5
5	10796401	1	270C	COTTER PIN 2,7x27,6	COPIGLIA 2,7x27,6
6	12638621	1	131R	WASHER 10,2x18	ROSETTA 10,2x18
7	12642701	1	131R	WASHER 8,15x12	ROSETTA 8,15x12
8	14163270	2	200S	PIN 4,4x26	SPINA 4,4x26
9	16043231	2	40V	SCREW 8x1,25x16	VITE 8x1,25x16
10	16043931	1	40V	SCREW 8x1,25x35	VITE 8x1,25x35
11	16102321	1	10D	NUT 8x1,25x5	DADO 8x1,25x5
12	76010540	1	142T	TIEROD - FRONT	TIRANTE - ANTERIORE
13	79036919	1	60P	PEDAL	PEDALE
14	79034241	1	100M	SPRING	MOLLA
15	79034242	1	45L	LEVER - FRONT	LEVA - ANTERIORE
16	79034246	1	16A	SHAFT	ALBERO
17	79034255	1	157R	ROLLER	RULLO
18	79034256	1	80P	PIN	PERNO
19	79034258	1	80M	BRACKET	MENSOLA
20	79035034	2	80P	PIN	PERNO
21	79036913	1	30G	HOOK	GANCIO
22	10902821	2	40V	SCREW 6x1x30	VITE 6x1x30
23	76010357	1	45L	LEVER	LEVA
24	12646601	2	170R	LOCKWASHER 6,15x15	ROSETTA EL. 6,15x15
25	12574211	2	10D	NUT 6x1x7,8	DADO 6x1x7,8
26	10124876	1	45F	CLIP 14x15	FERMAGLIO 14x15
27	10124411	1	119T	HEAD 6x1x10	TESTA 6x1x10

THROTTLE CONTROL LINKAGE - COMANDI ACCELERATORE - COMMANDES D'ACCELERATEUR -
 GASREGULIERUNG - MANOS DEL ACELERADOR

A2.21

1A

N.T.R. 200 - 15.10.1990

604.01.081.05

L5

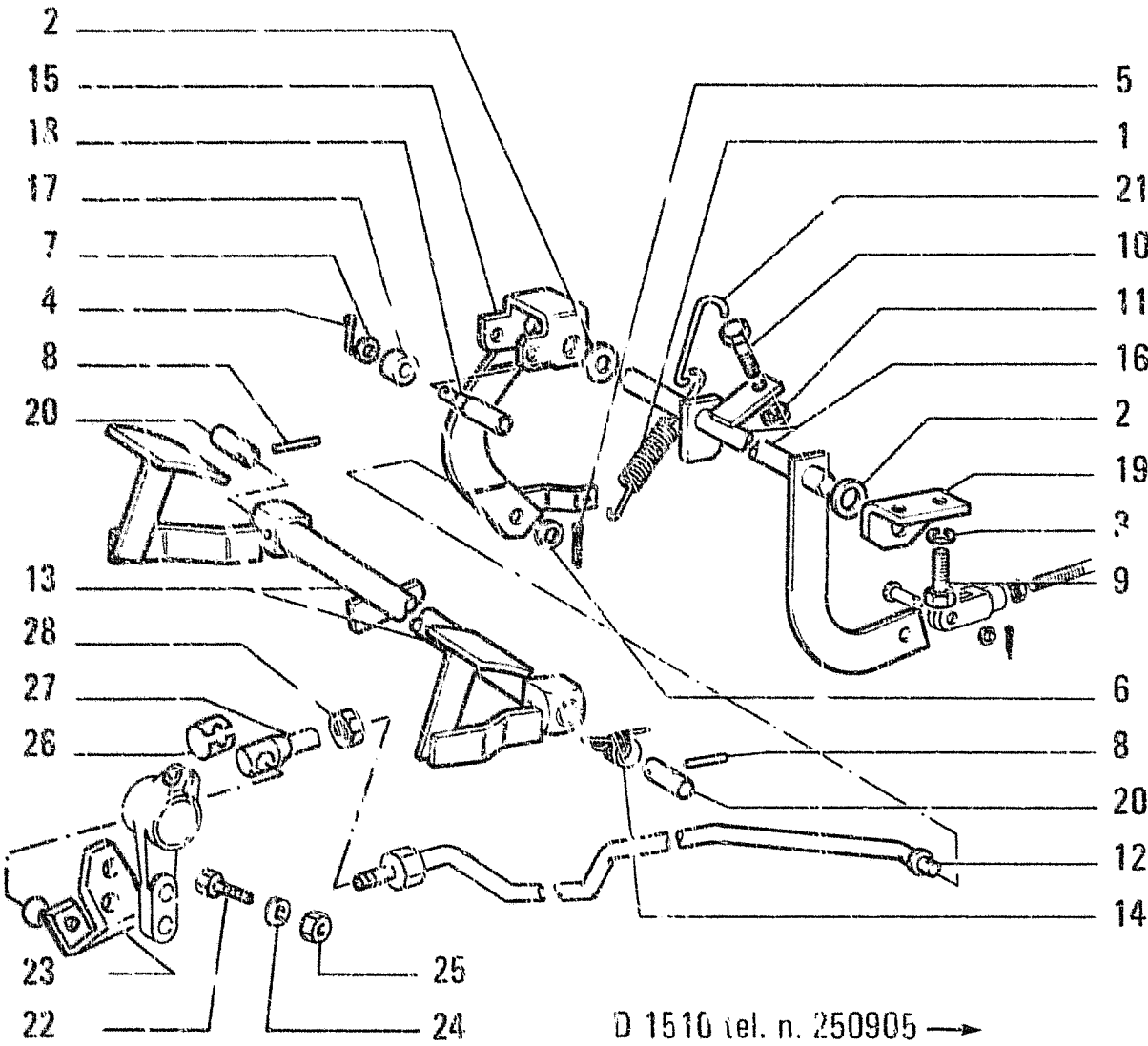

ITEM	PART NUMBER	QTY	TRANS CODE	DESCRIPTION	DESCRIZIONE
28	15896211	1	10D	NUT 6x1x5	DADO 6x1x5

THROTTLE CONTROL LINKAGE - COMANDI ACCELERATORE - COMMANDES D'ACCELERATEUR -
 GASREGULIERUNG - MANDOS DEL ACELERADOR

A2.21 1A
 N.T.R. 200 - 15.10.1990
 604.01.081.05

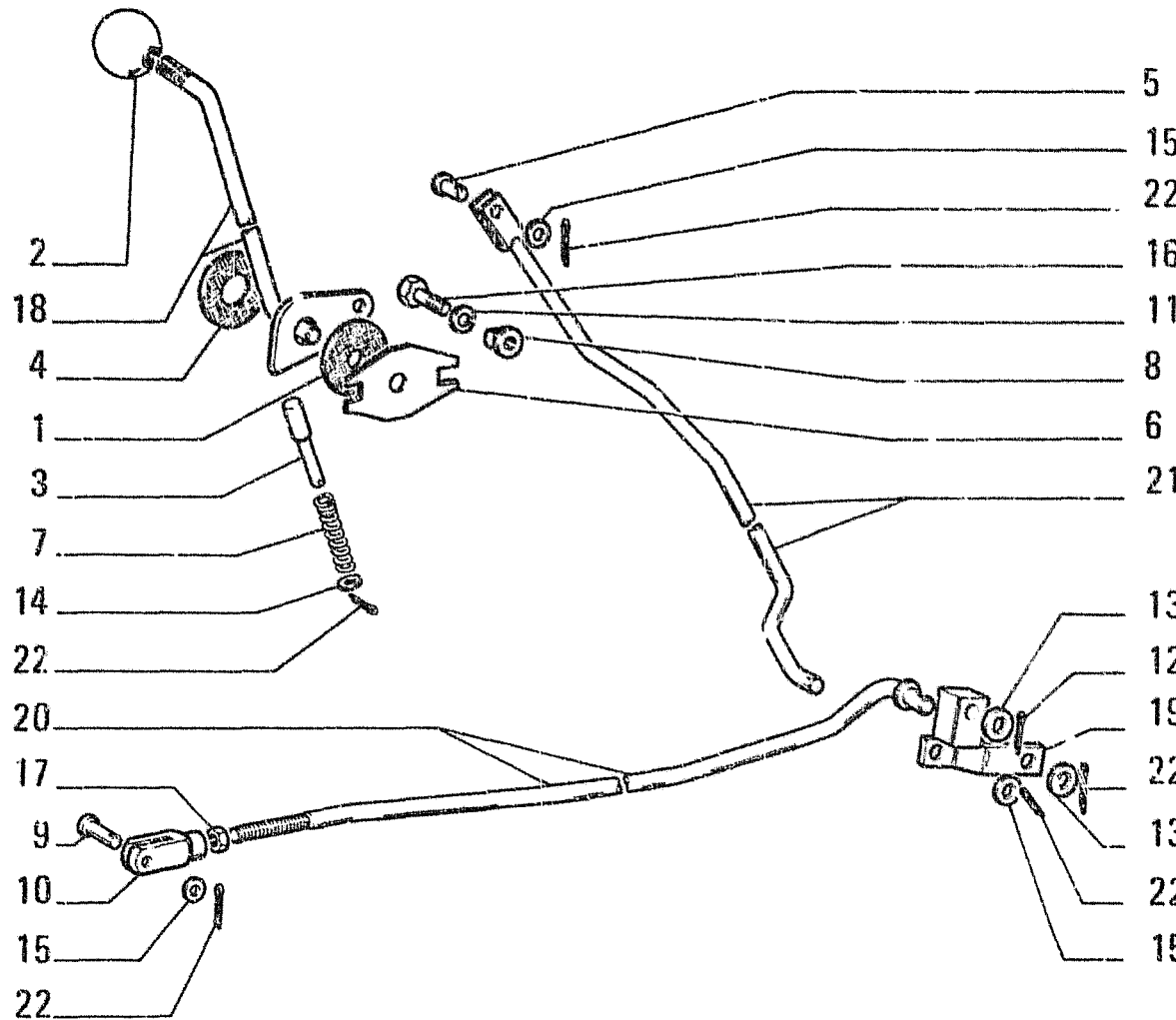

ITEM	PART NUMBER	QTY	TRANS CODE	DESCRIPTION	DESCRIZIONE
1	587468	1	60D	DISC	DISCO
2	4970504	1	25I	HANDGRIP	IMPUGNATURA
3	4984517	1	80P	PIN	PERNO
4	4984525	1	60D	DISC	DISCO
5	4984549	1	80P	PIN	PERNO
6	4984550	1	100M	SPRING	MOLLA
7	4989488	1	100M	SPRING	MOLLA
8	4989767	2	10D	NUT	DADO
9	10050811	1	80P	PIN 8x24	PERNO 8x24
10	10248271	1	85F	YOKE 8x1,25x8	FORCELLA 8x1,25x8
11	10516671	2	132R	LOCKWASHER 8,1x2,2	ROSETTA DI SICUREZZA 8,1x2,2
12	10796301	1	270C	COTTER PIN 2,7x21,6	COPIGLIA 2,7x21,6
13	12638601	2	131R	WASHER 10,2x18	ROSETTA 10,2x18
14	12639701	1	131R	WASHER 6,15x11	ROSETTA 6,15x11
15	12642701	3	131R	WASHER 8,15x12	ROSETTA 8,15x12
16	13279611	2	40V	SCREW 8x1,25x25	VITE 8x1,25x25
17	16102311	1	10D	NUT 8x1,25x5	DADO 8x1,25x5
18	76001632	1	45L	LEVER	LEVA
19	79026121	1	45L	LEVER - REAR	LEVA - POSTERIORE
20	79036707	1	141T	THREADED TIEROD	TIRANTE FILETTATO
21	79036906	1	142T	TIEROD - UPPER	TIRANTE - SUPERIORE
22	10734201	5	270C	COTTER PIN 1,7x18,5	COPIGLIA 1,7x18,5

THROTTLE CONTROL LINKAGE - COMANDI ACCELERATORE - COMMANDES D'ACCELERATEUR -
GASREGULIERUNG - MANDOS DEL ACELERADOR

2

A2.21

2

L7

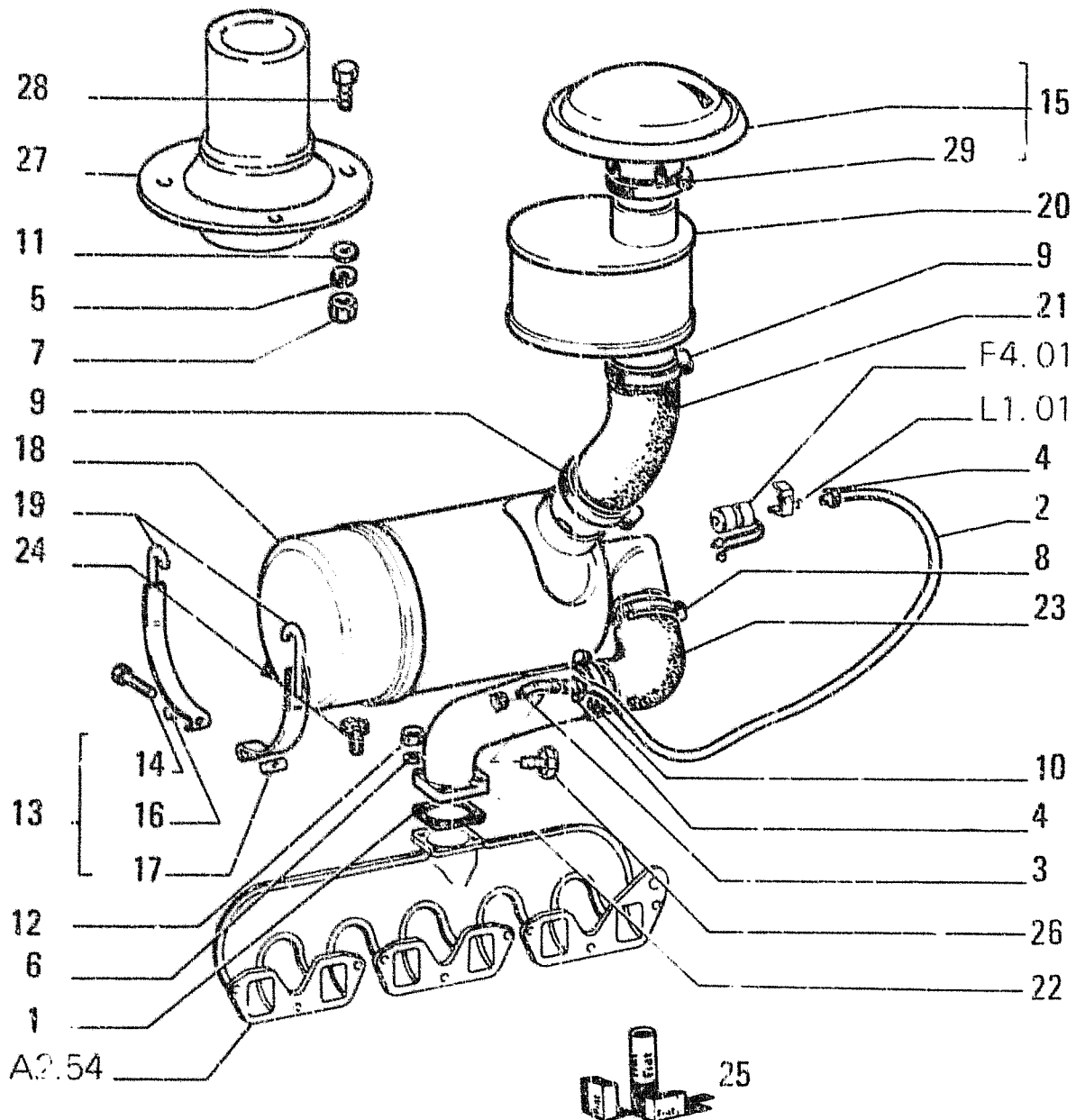

ITEM	PART NUMBER	QTY	TRANS CODE	DESCRIPTION	DESCRIZIONE
1	4632108	1	123G	SEAL ASSY C3341	GUARNIZIONE TENUTA FRONTALE C3341
2	4858085	1	122G	SEAL D3341	GUARNIZIONI D3341
	4950745	1	192T	HOSE ASSY - WRONG	TUBO FLESSO/RACCORDI - ERRATA
	19053382	1	192T	HOSE ASSY - CORRECT 10x15 C1510	TUBO FLESSO/RACCORDI CORRIGE 10x15 C1510
3	4951845	1	20R	FITTING C1510	RACCORDO C1510
4	10168790	2	180C	COLLAR 15.5x1 C1510	COLLARE 15.5x1 C1510
5	10516871	3	132R	LOCKWASHER 10x2.5	ROSETTA DI SICUREZZA 10x2.5
6	11194071	4	132R	LOCKWASHER 8.4x16	ROSETTA DI SICUREZZA 8.4x16
7	11701711	3	10D	NUT 10x1.5x8	DADO 10x1.5x8
8	12174490	1	180C	COLLAR 92/112x14	COLLARE 92/112x14
9	12174590	2	180C	COLLAR 107/127x14	COLLARE 107/127x14
10	12174990	1	180C	COLLAR 77/97x14	COLLARE 77/97x14
11	12646801	3	131R	WASHER 10.2x25	ROSETTA 10.2x25
12	16100821	4	10D	NUT - WRONG 8x1.25x6.5	DADO - ERRATA 8x1.25x6.5
13	76000174	2	40V	SCREW - ASSEMBLY	VITE - COMPLETO
14	76000175	1	40V	SCREW	VITE
15	76000208	1	204P	AIR INTAKE - ASSEMBLY	PRESA ARIA - COMPLETO
16	79007569	1	74B	BLOCK	BLOCCETTO
17	79007570	1	74B	BLOCK	BLOCCETTO
18	79015411	1	F9F	AIR CLEANER - ASSEMBLY SEE SGR. A2 23	FILTRO ARIA - COMPLETO VEDERE SGR. A2 23
19	79015697	4	225S	BRACKET	STAFFA
20	79027942	1	193T	TUBE (*)	TUBO RIGIDO (*)
21	76015617	1	30M	SLEEVE D2906	MANICOTTO D2906
	79036682	1	30M	SLEEVE C2906	MANICOTTO C2906

AIR CLEANER AND DUCTS – FILTRO ARIA E TUBAZIONI – FILTRE A AIR ET CANALISATIONS –
 LUFTFILTER UND LEITUNGEN – FILTRO DE AIRE Y TUBERÍAS

1
 A2.22
 N.T.R. 200 - 15.10.1990
 604.01.081.05

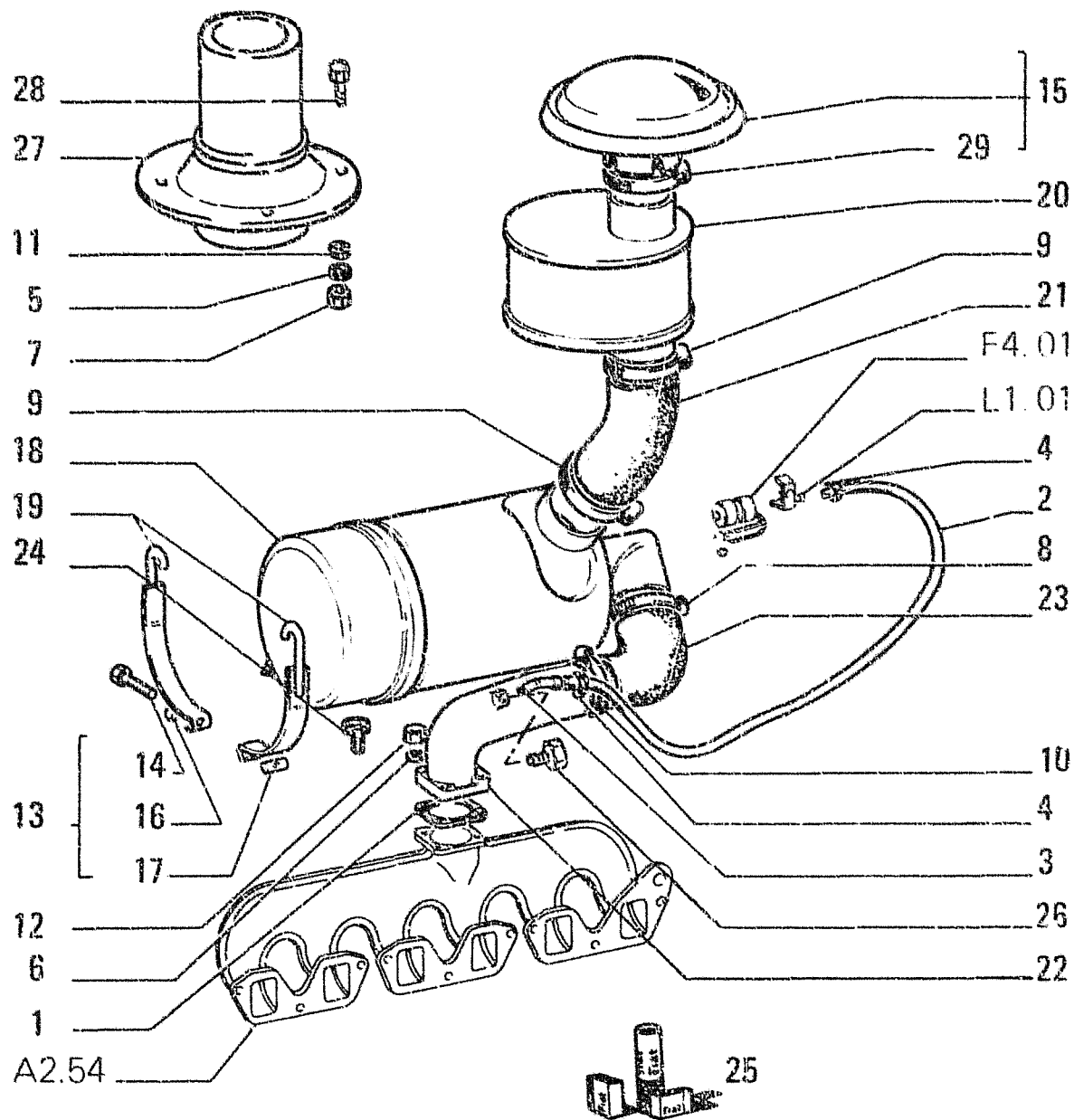

FIATALLIS FD7

A2.22 TAV. 1 PAG.2

ITEM	PART NUMBER	QTY	TRANS CODE	DESCRIPTION	DESCRIZIONE
22	79036679	1	85G ELBOW	GOMITO	
23	76015616	1	30M SLEEVE D2906	MANICOTTO D2906	
	79036681	1	30M SLEEVE C2906	MANICOTTO C2906	
24	16043631	4	40V SCREW - CORRECT 8x1,25x25	VITE - CORRIGE 8x1,25x25	
25	79055596	1	IK KIT SEE PAGE 9 C1572	KIT VED PAG 9 C1572	
	79086428	1	IK KIT SEE PAGE 9 D1572	KIT VED PAG 9 D1572	
26	14326050	1	50T PLUG 10x1,25x11 D1510	TAPPO 10x1,25x11 D1510	
27	79052161	1	193T TUBE D1507	TUBO RIGIDO D1507	
28	16160111	3	40V SCREW 10x1,5x50 D1507	VITE 10x1,5x50 D1507	
29	12174490	1	180C COLLAR 92/112x14 C2909	COLLARE 92/112x14 C2909	
	79083851	1	180C COLLAR D2909	COLLARE D2909	
(*)			469P FOR SPECIAL EQUIPMENT 30 0022.31 1		PER VARIANTE 30.0022.31 1

AIR CLEANER AND DUCTS - FILTRO ARIA E TUBAZIONI - FILTRE A AIR ET CANALISATIONS -
 LUFTFILTER UND LEITUNGEN - FILTRO DE AIRE Y TUBERIAS

1

A2.22

N.T.R. 200-15.10.1990

604.01.081.05

L9

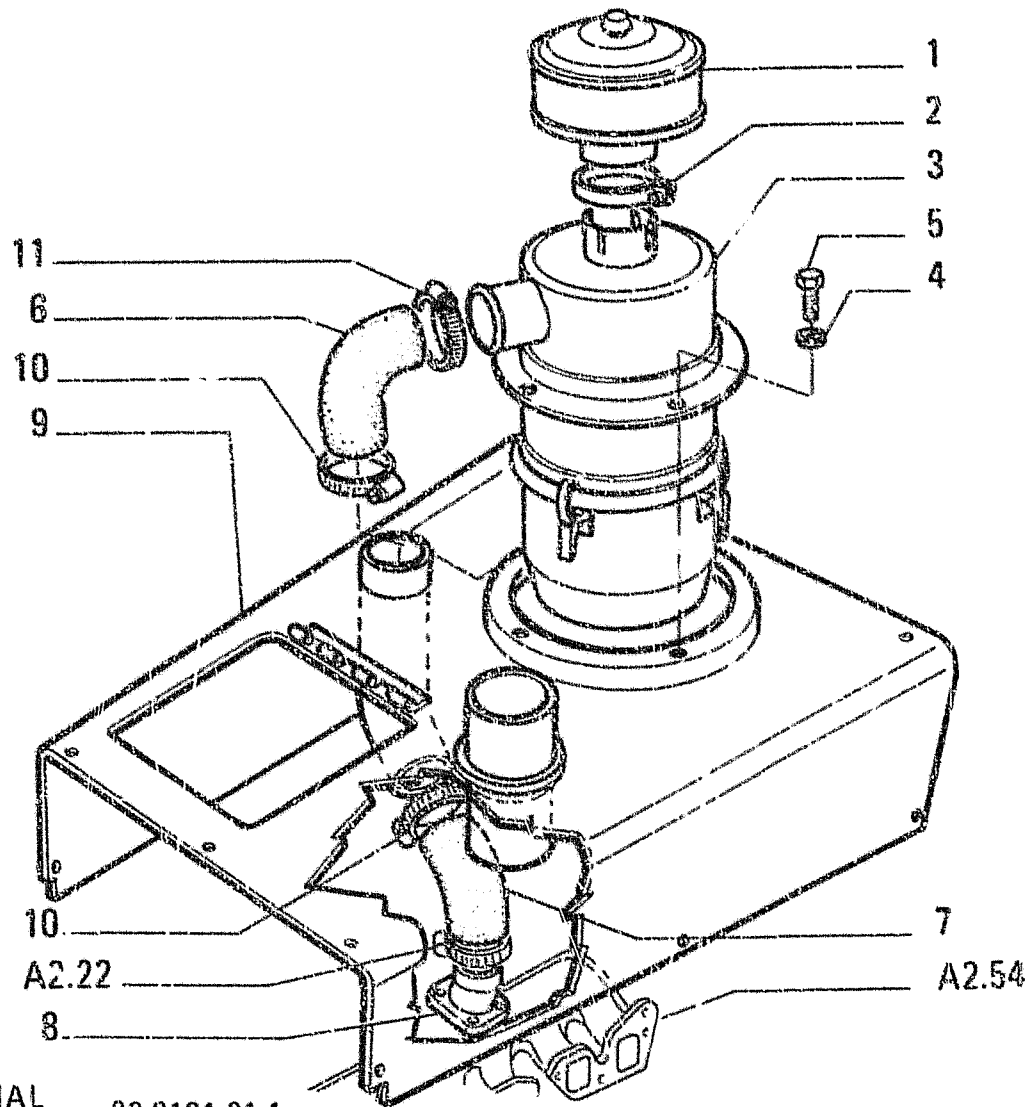

OPTIONAL
VARIANTE

30.0191.21.1

I T E M	PART NUMBER	Q T Y	TRANS CODE	DESCRIPTION	DESCRIZIONE
1	4980338	1	204P	AIR INTAKE - ASSEMBLY SEE SGR. A223/2	PRESA ARIA - COMPLETO VEDERE SGR. A223/2
2	4990624	1	180C	COLLAR	COLLARE
3	8323149	1	71F	OIL BATH AIR CLEANER - ASSEMBLY SEE SGR. A223/1	FILTRO ARIA BAGNO OLIO - COMPLETO VEDERE SGR. A223/1
4	10571871	4	170R	LOCKWASHER 10,2x2,2	ROSETTA EL 10,2x2,2
5	10979291	4	40V	SCREW 10x1,5x16	VITE 10x1,5x16
6	76015614	1	30M	SLEEVE	MANICOTTO
7	76015615	1	30M	SLEEVE	MANICOTTO
8	79043193	1	193T	TUBE	TUBO RISIDO
9	79043201	1	176C	HOOD	COFANO
10	79083849	2	180C	COLLAR	COLLARE
11	79083850	1	180C	COLLAR	COLLARE

AIR CLEANER AND DUCTS - FILTRO ARIA E TUBAZIONI - FILTRE A AIR ET CANALISATIONS -
LUFTFILTER UND LEITUNGEN - FILTRO DE AIRE Y TUBERIAS

A2.22/1

N.T.R. 191 - 29.02.1990

604.01.081.04

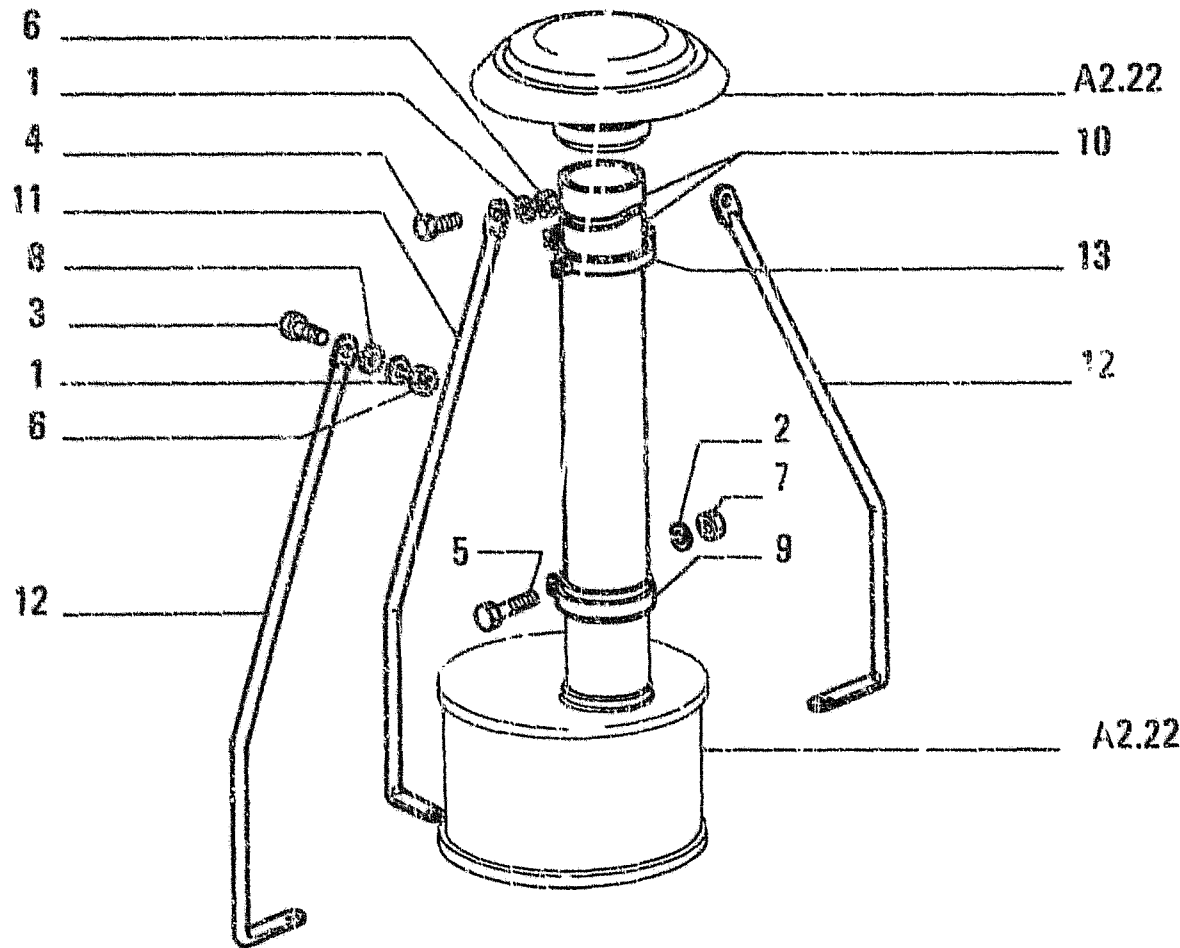

OPTIONAL
VARIANTE 30.0192.14.1

ITEM	PART NUMBER	QTY	TRANS CODE	DESCRIPTION	DESCRIZIONE
1	10571871	3	170H	LOCKWASHER 10,2x2,2	ROSETTA EL. 10,2x2,2
2	10571971	1	170R	LOCKWASHER 12,2x2,5	ROSETTA EL. 12,2x2,5
3	11106231	2	40V	SCREW 10x1,5x25	VITE 10x1,5x25
4	11106331	1	40V	SCREW 10x1,5x35	VITE 10x1,5x35
5	11112431	1	40V	SCREW 12x1,75x30	VITE 12x1,75x30
6	11701721	3	10D	NUT 10x1,5x8	DADO 10x1,5x8
7	11702921	1	10D	NUT 12x1,75x10	DADO 12x1,75x10
8	12646821	2	131R	WASHER 10,2x25	ROSETTA 10,2x25
9	79026197	1	180C	COLLAR	COLLARE
10	79042598	1	193T	TUBE	TUBO RIGIDO
11	79042599	1	142T	TIE ROD	TIRANTE
12	79042600	2	142T	TIE ROD	TIRANTE
13	79042602	1	180C	COLLAR	COLLARE

AIR CLEANER AND DUCTS - FILTRO ARIA E TUBAZIONI - FILTRE A AIR ET CANALISATIJSNS -
LUFTFILTER UND LEITUNGEN - FILTRO DE AIRE Y TUBERIAS

A2.22/2

N.T.R. 191 - 20.02.1990

604.01.081.04

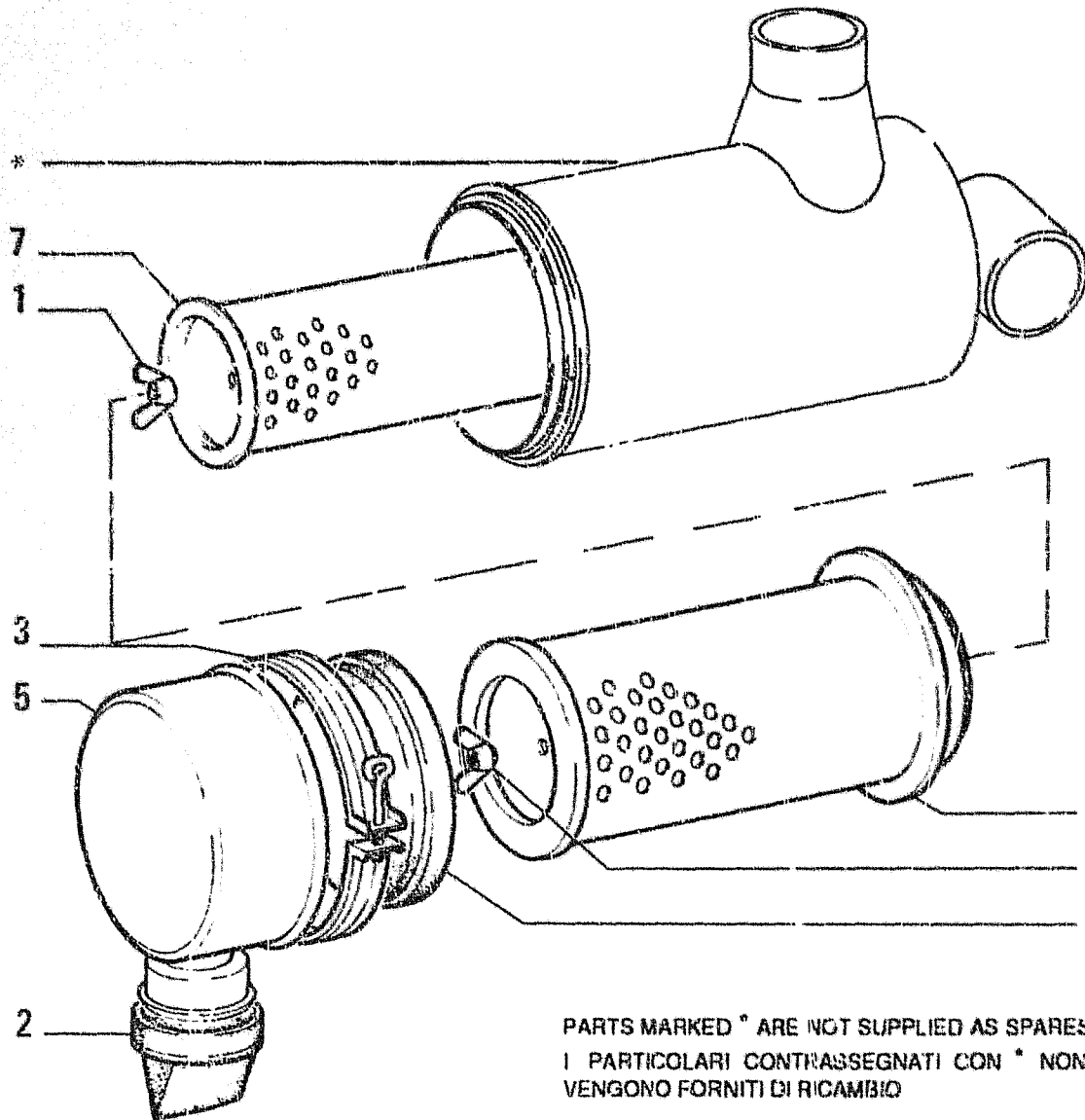

ITEM	PART NUMBER	QTY	TRANS CODE	DESCRIPTION	DESCRIZIONE
1	70239517	2	10D	NUT	DADO
2	70584057	1	10V	VALVE	VALVOLA
3	71004653	1	31F	CLAMP	FASCETTA
4	73046863	1	265C	COVER	COPERCHIO
5	73046864	1	19V	PAN	VASCHETTA
6	79011386	1	20E	FILTERING ELEMENT	ELEMENTO FILTRANTE
7	79011387	1	20E	FILTERING ELEMENT	ELEMENTO FILTRANTE

PARTS MARKED * ARE NOT SUPPLIED AS SPARES
 I PARTICOLARI CONTRASSEGNA TI CON * NON VENGONO FORNITI DI RICAMBIO

79015411

AIR CLEANER - FILTRO ARIA - FILTRE A AIR - LUFTFILTER - FILTRO DE AIRE

L12

1	A2.23
N.T.R. 200 - 15.10.1990	
604.01.081.05	

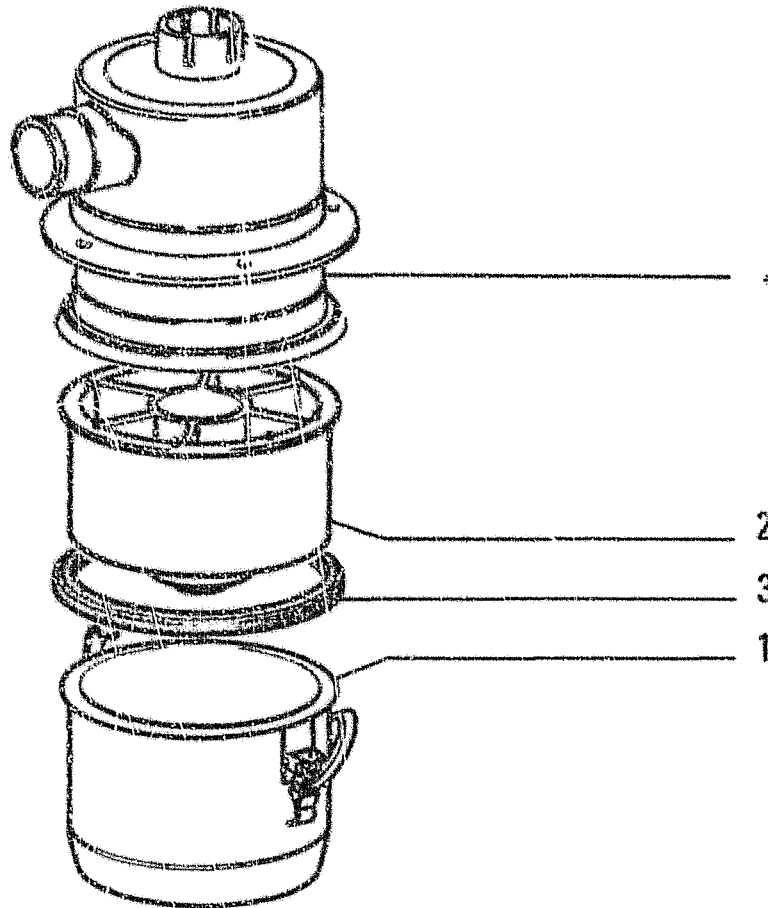

ITEM	PART NUMBER	QTY	TRANS CODE	DESCRIPTION	DESCRIZIONE
1	4990617	1	19V PAN		VASCETTA
2	8322167	1	20E FILTERING ELEMENT		ELEMENTO FILTRANTE
3	8322178	1	158G O-RING		GUARNIZIONE O-R

OPTIONAL
VARIANTE

30.0191.21.1

PARTS MARKED * ARE NOT SUPPLIED AS SPARES
I PARTICOLARI CONTRASSEGNA TI CON * NON
VENGONO FORNITI DI RICAMBIO

8323149

AIR CLEANER - FILTRO ARIA - FILTRE A AIR - LUFTFILTER - FILTRO DE AIRE

L13

A2.23/1

N.T.R. 200 - 15.10.1990
604.01.081.05

ITEM	PART NUMBER	QTY	TRANS CODE	DESCRIPTION	DESCRIZIONE
1	562515	1	131R	WASHER	ROSETTA
2	4962642	1	150P	KNOB	POMELLO
3	4962641	1	255C	FILTER SHELL	CONTENITORE FILTRO
4	593738	1	265C	COVER	COPERCHIO

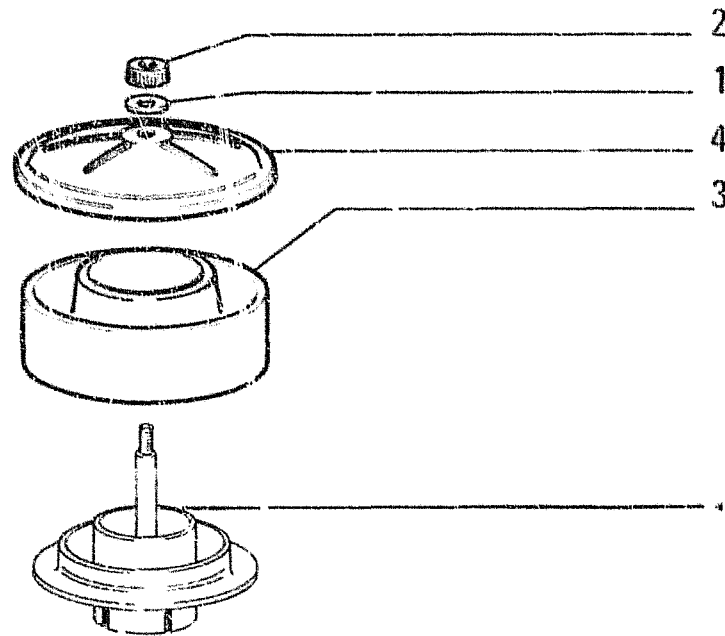

OPTIONAL VARIANTE 60.0191.21 1

PARTS MARKED * ARE NOT SUPPLIED AS SPARES
I PARTICOLARI CONTRASSEGNA TI CON * NON VENGONO FORNITI DI RICAMBIO

4980338
PRE - FILTER - PREFILTRO ARIA - PREFILTRE A AIR - VORREINIGER - PREFILTRO DE AIRE

A2.23/2

N.T.N. 200 - 15.10.1990

604.01.081.05

L14

VSA

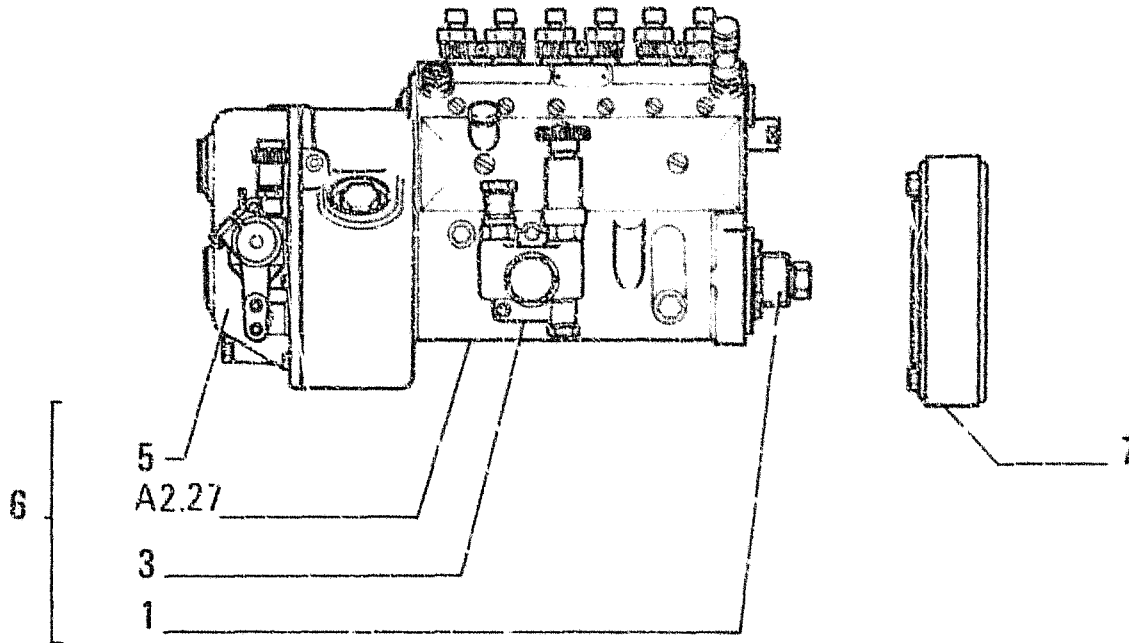

ITEM	PART NUMBER	QTY	TRANS CODE	DESCRIPTION	DESCRIZIONE
1	767373	1	94B	GROOVED BUSH -3	BOCCOLA SCANALATA -3
	767374	1	94B	GROOVED BUSH +3	BOCCOLA SCANALATA +3
3	767893	1	154P	FUEL PUMP - ASSEMBLY SEE SGR. A2.25	POMPA ALIMENTAZIONE - COMPLETO VEDERE SGR. A2.25
5	771646	1	28R	SPEED GOVERNOR - ASSEMBLY SEE SGR. A2.25	REGOLATORE DI VELOCITA' - COMPLETO VEDERE SGR. A2.28
6	4753555	1	109G	INJECTION EQUIPMENT - ASSEMBLY	GRUPPO INIEZIONE - COMPLETO
7	4758943	1	16V	ADVANCE VARIATOR - ASSEMBLY SEE SGR. A2.33	VARIATORE DI ANTICIPO - COMPLETO VEDERE SGR. A2.33

G 1572 → Tel.n. 250904

FUEL INJECTION SYSTEM – ALIMENTAZIONE AD INIEZIONE – ALIMENTATION PAR INJECTION –
EINSPRITZAUSRUESTUNG – ALIMENTACION POR INYECCION

A2.24

1

N.T.R. 205 - 30.09.1991
604.01.081.06

L15

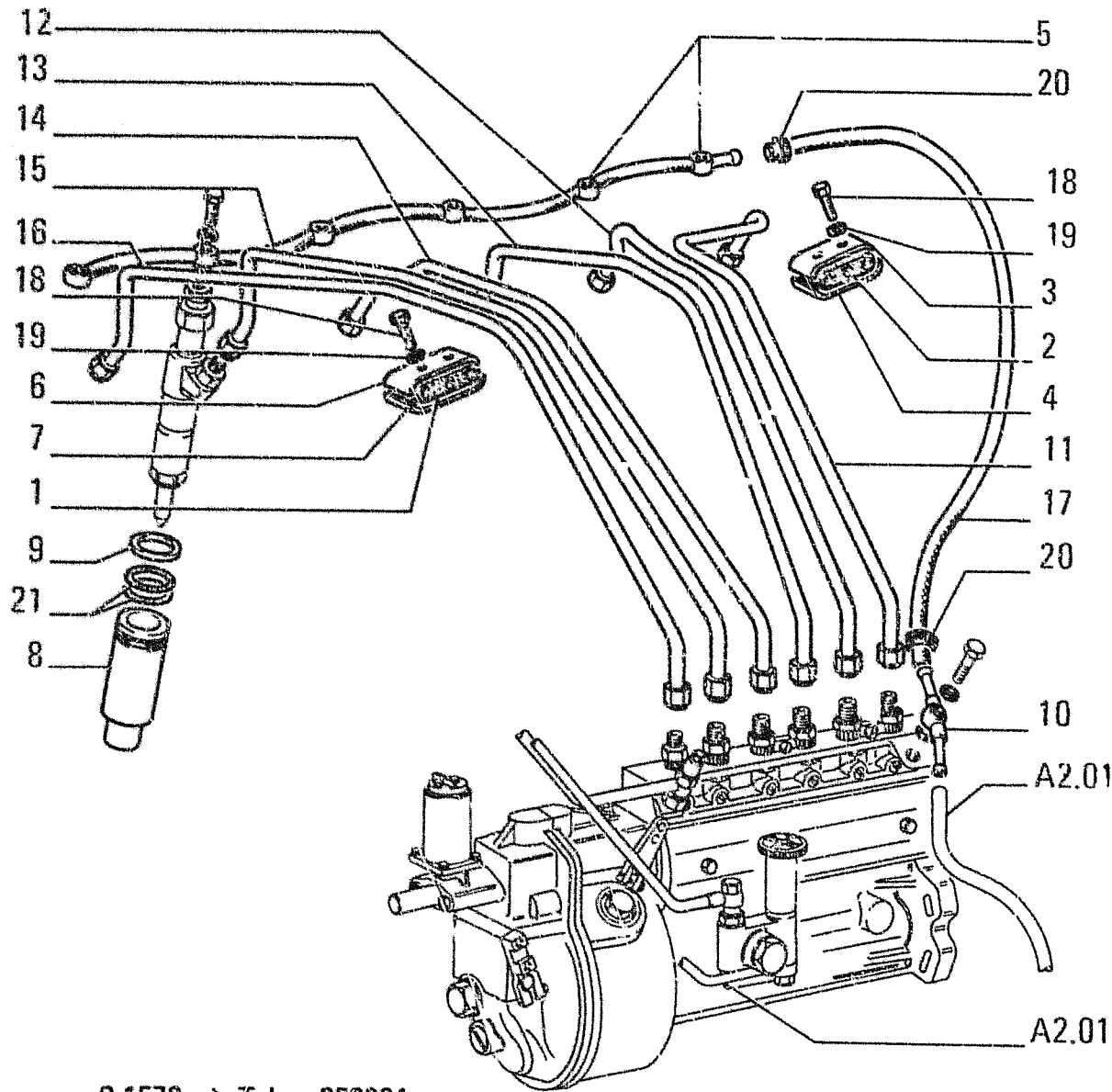

C 1572 → Tel.n. 250904

FIATALLIS FD7

ITEM	PART NUMBER	QTY	TRANS CODE	DESCRIPTION	DESCRIZIONE
1	4543282	1	78B	FASTENING BLOCK	BLOCCHETTO DI FISSAGGIO
2	4592280	2	78B	FASTENING BLOCK	BLOCCHETTO DI FISSAGGIO
3	4641873	2	97S	HALF CONNECTOR - UPPER	SEMIMORSETTO - SUPERIORE
4	4641874	2	97S	HALF CONNECTOR - LOWER	SEMIMORSETTO - INFERIORE
5	4647815	1	193T	TUBE	TUBO RIGIDO
6	4689110	1	97S	HALF CONNECTOR - UPPER	SEMIMORSETTO - SUPERIORE
7	4689111	1	97S	HALF CONNECTOR - LOWER	SEMIMORSETTO - INFERIORE
8	4699153	6	101A	CASING	ASTUCCIO
9	4717654	6	158G	O-RING - OUTER	GUARNIZIONE O-R - ESTERNO
10	4739148	1	193T	TUBE	TUBO RIGIDO
11	4754629	1	193T	TUBE	TUBO RIGIDO
12	4754630	1	193T	TUBE	TUBO RIGIDO
13	4754631	1	193T	TUBE	TUBO RIGIDO
14	4754632	1	193T	TUBE	TUBO RIGIDO
15	4754633	1	193T	TUBE	TUBO RIGIDO
16	4754634	1	193T	TUBE	TUBO RIGIDO
17	4760285	1	192T	HOSE ASSY	TUBO FLESS.C/RACCORDI
18	10978021	4	4/W	SCREW 5x0,8x20	VITE 5x0,8x20
19	11195470	4	132R	LOCKWASHER 5,1x1,1	ROSETTA DI SICUREZZA 5,1x1,1
20	12179490	2	180C	COLLAR 9/16x8	COLLARE 9/16x8
21	14453981	12	158G	O-RING 1,78x25,12	GUARNIZIONE O-R 1,78x25,12

FUEL INJECTION SYSTEM - ALIMENTAZIONE AD INIEZIONE - ALIMENTATION PAR INJECTION -
EINSPRITZAUSRÜSTUNG - ALIMENTACION POR INYECCION

A2.24

2

N.T.R. 158 - 13.03.1987

604.01.081.03

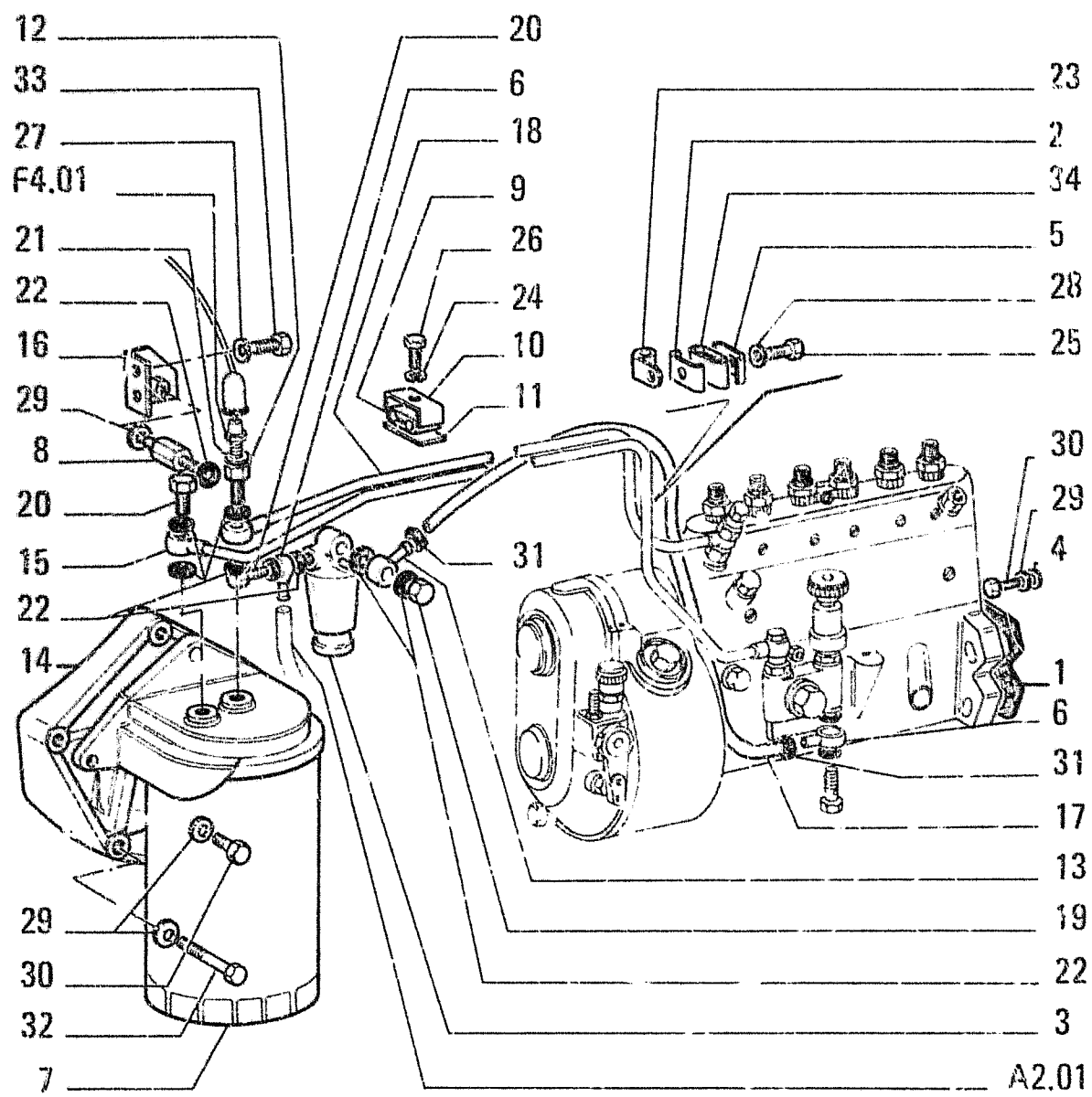

C 1572 → Tel.n. 250904

FIATALLIS FD7

ITEM	PART NUMBER	QTY	TRANS CODE	DESCRIPTION	DESCRIZIONE
1	561353	1	123G	SEAL ASSY G3341	GUARNIZIONE TENUTA FRONTALE G3341
	4858086	1	122G	SEAL D3341	GUARNIZIONE D3341
2	607942	1	97S	HALF CONNECTOR	SEMIMORSETTO
3	740314	1	201P	PRECLEANER	PREFILTRO
4	759850	4	131R	WASHER	ROSETTA
5	4002890	1	97S	HALF CONNECTOR	SEMIMORSETTO
6	4551493	2	20R	FITTING	RACCORDO
7	4618309	1	64F	FUEL FILTER - ASSEMBLY SEE SGR A2.26	FILTRO COMBUSTIBILE - COMPLETO VEDERE SGR A2.26
8	4623038	1	20R	FITTING	RACCORDO
9	4659217	2	78B	FASTENING BLOCK	BLOCCETTO DI FISSAGGIO
10	4659218	2	97S	HALF CONNECTOR	SEMIMORSETTO
11	4659219	2	110P	PLAQUE	PIASTRINA
12	4724015	1	20R	FITTING	RACCORDO
13	4741072	1	20R	FITTING	RACCORDO
14	4758953	1	390S	SUPPORT	SUPPORTO
15	4764170	1	193T	TUBE	TUBO RIGIDO
16	4764887	1	225S	BRACKET	STAFFA
17	4765047	1	192T	HOSE ASSY	TUBO FLESSIB./RACCORDI
18	4765266	1	193T	TUBE	TUBO RIGIDO
19	10182811	1	50T	PLUG 14x1,5x14	TAPPO 14x1,5x14
20	10184317	2	20R	FITTING 14x1,5x27	RACCORDO 14x1,5x27
21	10260160	1	133R	SEAL 10,2x14	ROSETTA DI TENUTA 10,2x14
22	10280060	12	133R	SEAL 14,2x20	ROSETTA DI TENUTA 14,2x20
23	10441390	4	231S	CLIP 12x7	STAFFETTA 12x7
24	10571471	2	132R	LOCKWASHER 5,1x1,2	ROSETTA DI SICUREZZA 5,1x1,2

FUEL INJECTION SYSTEM — ALIMENTAZIONE AD INIEZIONE — ALIMENTATION PAR INJECTION —
 EINSPRITZAUSRUESTUNG — ALIMENTACION POR INYECCION

	DESIGNAZIONE BASE	BASIC DESIGNATION	DESIGNATIONS-BASES	GRUNDEZEICHNUNGEN	DENOMINACIONES BASE
159C	CILINDRO FRENO	BRAKE CYLINDER	CYLINDRE DE FREIN	BREMSZYLINDER	CILINDRO DE FRENO
159G	GUARNIZIONE LIQUIDA	GASKET LIQUID	PRODUIT LIQUID POUR ETANCHE	FLUESSIGDICHTUNG	SELLADOR
159R	RUOTA DENTATA	GEAR WHEEL	BARBOTIN	TRIEBRAD	RUEDA MOTRIZ
159S	SILENZIATORE SUPPLEMENTARE	AUXILIARY SILENCER	SILENCIEUX SUPPLEMENTAIRE	ZWISCHENAUSPUFFTOPF	SILENCIADOR SUPLEMENTARIO
159S					
160C	CHIOCCIOLA	LEAD NUT	ECROU EN CARACOLE	SPINDEL	TUERCA
160G	GRANULATO FERROSO	FERROUS GRANULATE	GRANULE FERRUGINEUX	KOERNIGES EISEN	GRANULADO DE HIERRO
160R	RUOTA	WHEEL	ROUE	RAD	RUEDA
160S	SILENZIATORE	MUFFLER	SILENCIEUX	SCHALLDAEMPFER	SILENCIADOR
160T	TRASMETTITORE	SENDING UNIT	TRANSMETTEUR	KONTAKTGEBER	CONTACTOR
160S	ATTREZZO SCRAPER	SCRAPER IMPLEMENT	EQUIPEMENT RACLOIR	SCRAPEREINRICHTUNG	
161C	CILINDRO, CLASSE	CYLINDER, CLASS...	CYLINDRE, CLASSE...	ZYLINDER, KLASSE...	CILINDRO, CLASE...
161G	GRASSO	GREASE	GRAISSE		
161P	POMPA IDRAULICA	HYDRAULIC PUMP	POMPE HYDRAULIQUE	HD-PUMPE	BOMBA HIDRAULICA
161R	RUOTA LIBERA	FREE WHEEL	ROUE LIBRE	FREILAUF	RUEDA LIBRE
161S	SINCRONIZZATORE	SYNCHRONIZER	SYNCHRONISIER	SYNCHRONISIERUNG	SINCRONIZADOR
162C	CILINDRO PNEUMATICO	AIR CYLINDER	CYLINDRE PNEUMATIQ	PNEUMATISCHER ZYLINDER	CILINDRO NEUMATICO
162C					
163C	CILINDRETTO	BARREL	CYLINDRE	ZYLINDER	CILINDRO
163R	RUOTA MOTRICE	SPROCKET	BARBOTIN MOTEUR	ANTRIEBSRAD	RUEDA MOTRIZ
164C	CILINDRO	CYLINDER	CYLINDRE	ZYLINDER	CILINDRO
164P	POMPA SERVOCOMANDO	SERVO CONTROL PUMP	POMPE DE SERVO-COMMANDE	SERVOSTEUERUNGSPUMPE	BOMBA DE SERVO-MANDO
164P					
164S	SMORZATORE	DAMPER	AMORTISSEUR	SCHWINGUNGS-DAEMPFER	ANTIVIBRADOR
164S					
165P	PONTE	AXLE	POINT	ACHSE	PUNTE
165R	RUTTORE	BREAKER	RUPTEUR	UNTERBRECHER	RUPTOR
165S	SNODO	ARTICULATION	ARTICULATION	GELENK	ARTICULACION
165T	TRASMISSIONE FLESSIBILE	FLEXIBLE SHAFT	TRANSMISSION FLEXIBLE	BIEGSAME WELLE	ARBOL FLEXIBLE
166C	CILINDRO DI COMANDO GANASCE	WHEEL CYLINDER	CYLINDRE DE ROUE	RADBREMSZYLINDER	CILINDRO DE FRENO
166R	RUOTA TENDICINGOLO	TRACK IDLER	ROUE TENDEUSE	LEITRAD	RUEDA DE GUIA
166S	SOFFIETTO	BELLOWS	SOUFFLEUR	CLASEBALG	FUELE
166T	TRECCIA DI MASSA	GROUND BRAID	TRESSE DE MASSE	MASSEBAND	TRENZA DE MASA
167C	CILINDRO DEL SERVOSTERZO	SERVO-ASSYSTED STEERING CYLINDER	CYLINDRE RECEPTEUR	ZYLINDER DER SERVOLENUNG	CILINDRO DE SERVO-DIRECCION
167C					
167T	RADIATORE ACQUA	WATER RADIATOR	RADIATOR A L'EAU	WASSERKUEHLER	RADIADOR DE AGUA
167S	SOLLEVATORE IDRAULICO	HYDRAULIC LIFTER	RELEVAGE HYDRAULIQUE	KRAFTHEBER HYDRAULISCH	LEVANTE HIDRAULICO
167T	TRASPARENTE DELLO STOP	STOPLAMP LENS	TRANSPARENT DE FEUX STOP	LICHTSCHEIBE DER BREMSLEUCHE	TAPA TRANSLUCIDA DE LUCES DE PARE
167T					
168R	RADIATORE OLIO	OIL RADIATOR	RADIATOR A HUILE	ÖLKUEHLER	RADIADOR DE ACEITE

DESIGNAZIONE BASE	BASIC DESIGNATION	DESIGNATIONS-BASES	GRÜNDBEZEICHNUNGEN	DENOMINACIONES BASE
150C	CHIAVE	KEY	SCHLUESSEL	LLAVE
150G	GUIDA DELLA VALVOLA	VALVE GUIDE	VENTILFUEHRUNG	GUIA DE VALVULA
150P	POMELLO	KNOB	KNEBELGRIFF	BOTON
150R	RUBINETTO	COCK	HAHN	GRIFO
150S	SIGLA	TRADE MARK	KENNZEICHEN	SIGLA
150T	TIMER	TIMER	TIMER	TIMER
150I	BARRA PORTATTREZZI	TOOL BAR	GERAETETRAEGER	BARRA
151B	BARRA	BAR	STREBE	BARRA
151C	CHIAVE A TUBO	PIPE WRENCH	STECKSCHLUESSEL	LLAVE DE TUBO
151G	GUIDA DELLA VALVOLA DI ASPIRAZIONE	INTAKE VALVE GUIDE	EINLASSVENTILFUEHRUNG	GUIA DE LA VALVULA DE ADMISION
151P	POMELLO DI FISSAGGIO	RETAINING KNOB	KLEMMKNOPF	POMO DE FIJACION
151P				
151S	SIGLA TRATTORE	TYPE PLATE	MODELLBEZEICHNUNG	SIGLA TRACTOR
152B	BENNA DA CAVA	QUARRY BUCKET	FELSSCHAUFEL	CUCHARA PARA CANTERA
152G	GUIDA DELLA VALVOLA DI SCARICO	EXHAUST VALVE GUIDE	AUSLASSVENTILFUEHRUNG	GUIA DE LA VALVULA DE ESCAPE
152G				
152P	POMPA ACQUA	WATER PUMP	WASSERPUMPE	BOMBA DE AGUA
153B	BENNA MORDENTE	CLAMHELL BUCKET	SCHALENGREIFER	CUCHARA MORDIENTE
153G	GUIDA DI SCORRIMENTO	SLIDE GUIDE	LAUFSCHIENE	GUIA DESLIZANTE
153P	POMPA OLIO	OIL PUMP	ÖLPUMPE	BOMBA DE ACEITE
154C	CHIAVE SERRATURA	LOCK KEY	SCHLUESSEL	LLAVE DE CERRADURA
154P	POMPA ALIMENTAZIONE	FUEL PUMP	KRAFTSTOFFPUMPE	BOMBA DE ALIMENTACION
155B	BENNA DA ROCCIA	ROCK BUCKET	FELSLOEFFEL	CUCHARA PARA ROCAS
155G	GIUNTO RAPIDO	QUICK-CONNECTING COUPLING	BOHNERKUPPLUNG	JUNTA RAPIDA
155P	POMPA	PUMP	PUMPE	BOMBA
157R	RULLINO	NEEDLE ROLLER	NADEL	RODILLO
155S	SILENTBLOC	SILENTBLOC	SILENTBLOC	SILENTBLOC
156B	BENNA TRAPEZOIDALE	TRAPEZOIDAL BUCKET	TRAPEZLOEFFEL	CUCHARA TRAPEZOIDAL
156G	GOLFARE	EYEBOLT	KUGELKOPF	ARGOLLA
156P	POMPA A MANO	HAND PUMP	HANDPUMPE	BOMBA DE MANO
157B	BENNA 4 IN 1	4-IN-1 BUCKET	4-IN-1-SCHAUFEL	CUCHARA MULTI-USO
157G	GUARNIZIONE ALBERO ROTANTE	LIP SEAL	WELLENDICHRING	JUNTA
157P	POMPA ARIA	AIR PUMP	LUFTPUMPE	BOMBA DE AIRE
157R	RULLO	ROLLER	ROLLE	RODILLO
158B	BUSTA	ENVELOPE	UMSCHLAG	SOBRE
158C	LINGUETTA A DISCO	WOODRUFF KEY	PASSFEDER	CHAVETA
158G	GUARNIZIONE O-R	O-RING	O-RING	GUARNICION TORICA
158P	POMPA INIEZIONE	INJECTION PUMP	EINSPRITZPUMPE	BOMBA DE INYECCION
158T	TRASFORMATORE	TRANSFORMER	TRANSFORMATOR	TRANSFORMADOR

DESIGNAZIONE BASE	BASIC DESIGNATION	DESIGNATIONS-BASES	GRUNDBEZEICHNUNGEN	DENOMINACIONES BASE	
140C	CERNIERA	HINGE	CHARNIERE	SCHARNIER	RISAGRA
140G	GUAINA FLESSIBILE	SHEATH	GAINÉ	HUELLE	FUNDA
140P	PLANCIA	PLANK	PLANCHE	WAND	TABLERO
140S	SFERA	BALL	BILLE	KUGEL	ESFERA
1401	LAMA ABBATTIMENTO		LAME ABATTAGE	RAMMSCHILD	
141M	MASTICE ADESIVO	PUTTY	MASTIC ADHESIF	DICHTUNGSMASSE	ALMACIGA ADHESIVA
141P	PLANCIA PORTASTRUMENTI	INSTRUMENT PANEL	TABLEAU DE BORD	INSTRUMENTENBRETT	CUADRO INSTRUMENTACION
141T	TIRANTE FILETTATO	THREADED TIEROD	TIRANT	SPANNBOLEN	PERNO
142G	GUAINA	SHEATH	GAINÉ	SCHUTZROHR	FUNDA
142M	MOLLA A BALESTRA	LEAF SPRING	FLOSSON A LAMES	BLATTFEDER	MUELLE DE BALLESTA
142T	TIRANTE	TIEROD	TIRANT	STANGE	TIRANTE
1421	LAMA CAVACEPPI		LAME DESOUCHEUSE	STUBBENRODER	
143M	MOTOASSALE	LIVE AXLE	ESSEIL MOTEUR	ACHSANTRIEB	EJE
143T	TIRANTE DI STERZO TRASVERSALE	TRACK ROD	BARRÉ D'ACCOUPLÉMENT	SPURSTANGE	BARRA DE ACOPLAMIENTO
1431	LAMA SPIETRATRICE		LAME SPIERREUSE	FELSRÉCHEN	
143M	MANIPOLATORE	MANIPULATOR	MANIPULATEUR	DRUCK FERNSTEUERUNG	
1441	TIRANTE DI STERZO LONGITUDINALE	DRAG LINK	BARRE DE DIRECTION	LENKSTANGE	BARRA DE DIRECCION
1440	LAMA DECESPUGLIATRICE PER AD		LAME DEBRUSSAILLEUSE AD	RODERÉCHEN (AD)	
1441	LAMA DECESPUGLIATRICE PER BD		LAME DEBRUSSAILLEUSE BD	RODERÉCHEN (BD)	
145B	BUSSOLA	GUIDE BUSHING	DOUILLE	GEWINDEBUECHSE	CASQUILLO
145G	GUIDA	GUIDE	GUIDE	FUEHRUNG	GUIA
145M	MAGLIA CINGOLO	TRACK LINK	MAILLON	KEITENGLIED	MALLA DE ORUGA
145P	PLANETARIO	SUN GEAR	PLANETAIRE	PLANETENANTRIEB	PINON PLANETARIO
145R	ROTORE	ROTOR	ROTOR	LAUFER	ROTOR
145S	SFIATATOIO	BREATHER	REMIFLARD	ENTLUEFTER	RESPIRADERO
146M	MODULO ANTERIORE	TOOL MODULE	MODULE ANTERIEUR		MODULO ANTERIOR
146R	ROTULA SFERICA	BALL JOINT	ROTULE	KUGELBUECHSE	ROTULA
146T	TIRANTE ELASTICO	ELASTIC TIEROD	TIRANT ELASTIQUE	FEDERSTANGE	VARILLA ELASTICA
147G	GUIDA DELLA MOLLA	SPRING GUIDE	GUIDE-RESSORT	FEDERFUEHRUNG	GUIA DE RESORTE
147M	MODULO POSTERIORE	POWER MODULE	MODULE POSTERIEUR		MODULO POSTERIOR
147P	PNEUMATICO	TIRE	PNEU	REIFEN	NEUMATICO
147T	TORRETTA	TURRET	TOURELLE	OBERWAGEN	TORRE
148P	POLVERIZZATORE	NOZZLE	PULVERISATEUR	EINSPRITZDUESE	PULVERIZADOR
148S	SI FORNISCONO SOLO LE PARTI	ONLY SEPARATE PARTS ARE SERVICED	UN LIVRE SEULEMENT SES PIECES	NUR EINZELTEILE LIEFERBAR	SOLO SE SUMINISTRAN LAS PIEZAS
148S					
148S					
148S					
148S					
148S	RUBINETTO-VALVOLA	COCK VALVE	ROBINET	VENTIL	SUeltas
148S	BORSA	BAG	TROUSSE	TASCHE	VALVULA
150B					BOLSA

A

ENGINE • MOTORE • MOTEUR • MOTOR • MOTOFI

M1

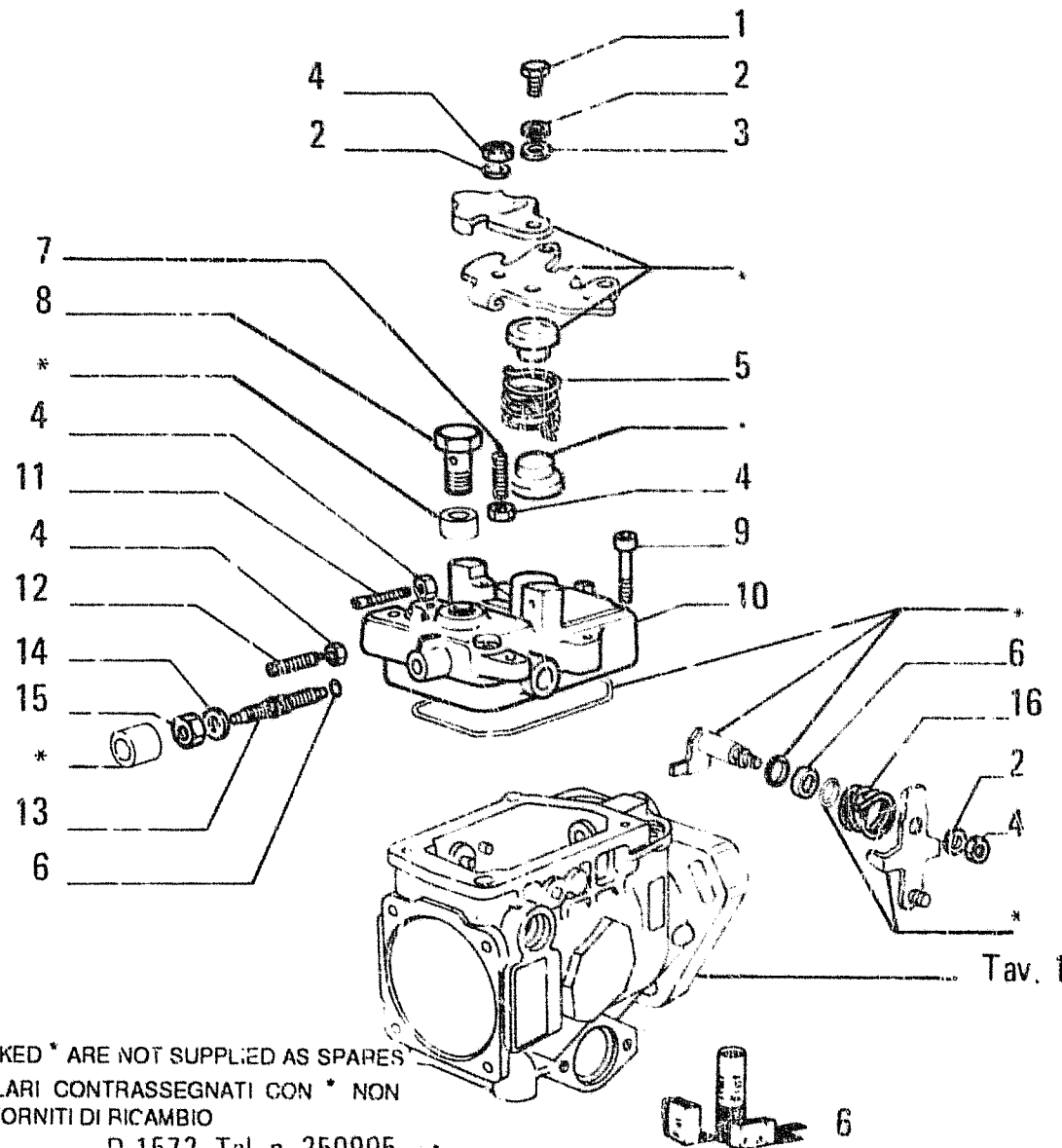

PARTS MARKED * ARE NOT SUPPLIED AS SPARES
 I PARTICOLARI CONTRASSEGNA TI CON * NON
 VENGONO FORNITI DI RICAMBIO

D 1572 Tel. n. 250905

ITEM	PART NUMBER	QTY	TRANS CODE	DESCRIPTION	DESCRIZIONE
1	10002021	1	40V	SCREW 5x1x12 C2952	VITE 6x1x12 C2952
	79086485	1	40V	SCREW D2952	VITE D2952
2	10571579	3	170R	LOCKWASHER 6,1x1,6	ROSETTA FL. 6,1x1,6
3	14496401	1	131R	WASHER 6,4x12,5 C2952	ROSETTA 6,4x12,5 C2952
	79035485	1	131R	WASHER D2952	ROSETTA D2952
4	15896211	5	10D	NUT 6x1x5	DADO 6x1x5
5	79032102	1	100M	SPRING C2952	MOLLA C2952
	79108165	1	100M	SPRING D2952	MOLLA D2952
6	79071400	1		2K KIT	KIT
	79071369	1		80P PIN	PERNO
8	79071368	1	20R	FITTING C2952	RACCORDO C2952
9	14305620	4	40V	SCREW 6x1x35	VITE 6x1x35
10	79082104	1	265C	COVER	COPERCHIO
11	79082109	1	40V	SCREW	VITE
12	79074024	1	210P	STUD	PRIGIONIERO
13	79082103	1	210P	STUD	PRIGIONIERO
14	79047121	1	131R	WASHER	ROSETTA
15	10726011	1	10D	NUT 8x1x5 C2952	DADO 8x1x5 C2952
	79106765	1	10D	NUT D2952	DADO D2952
16	79071371	1	100M	SPRING C2952	MOLLA C2952
	79094495	1	100M	SPRING D2952	MOLLA D2952

4807436

INJECTION PUMP - POMPA INIEZIONE - POMPE D'INJECTION - EINSPRITZPUMPE - BOMBA DE INYECCION

A2.27/A

2

N.T.R. 270 - 15.10.1990

604.01.081.05

M2

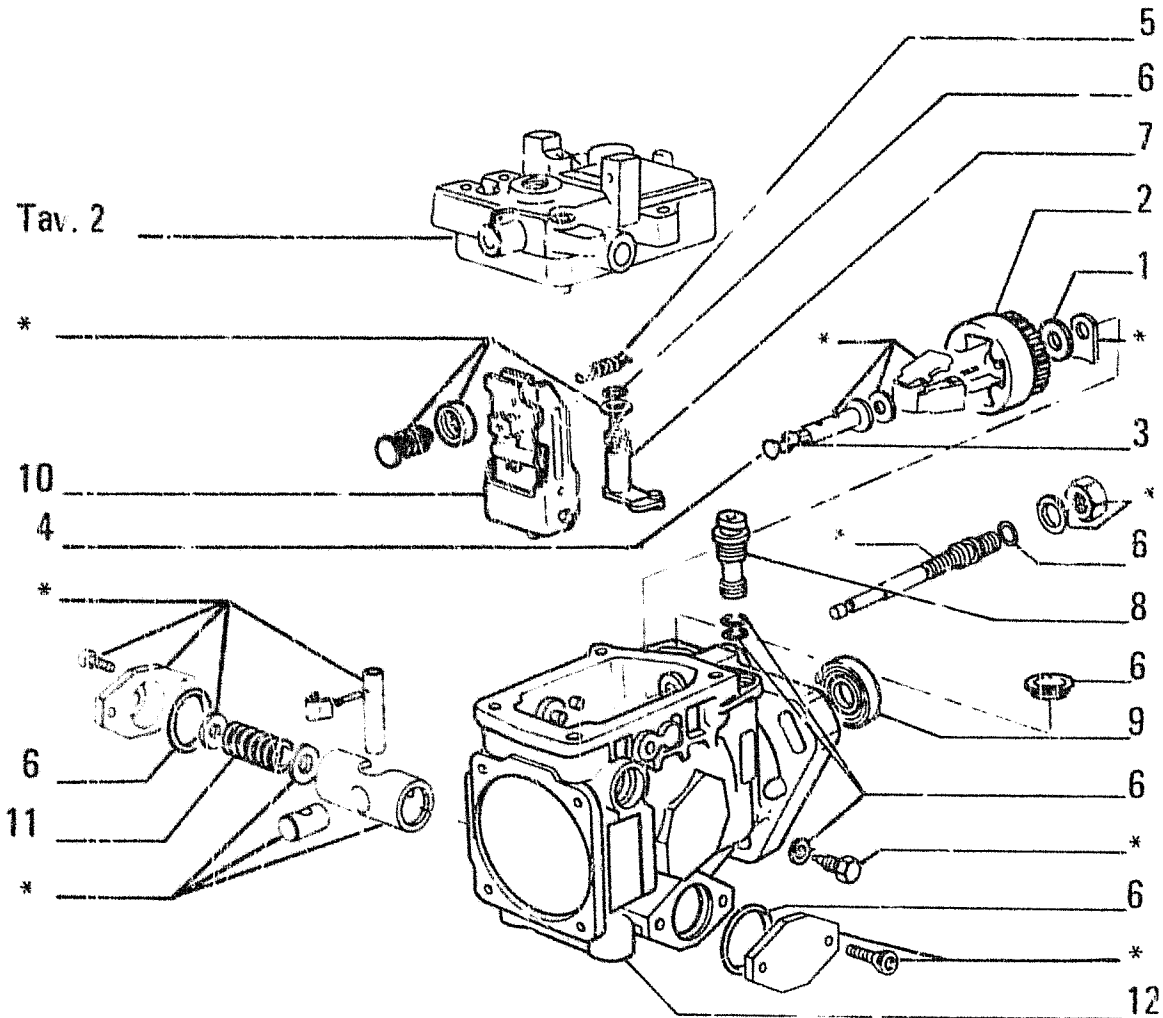

PARTS MARKED * ARE NOT SUPPLIED AS SPARES
 I PARTICOLARI CONTRASSEGNA TI CON * NON
 VENGONO FORNITI DI RICAMBIO

D 1572 Tel. n. 250905 -

I T E M	PART NUMBER	Q T Y	TRANS CODE	DESCRIPTION	DESCRIZIONE
1	79071378	1	131R	WASHFR	ROSETTA
2	79071377	1	169R	REGULATOR	REGOLATORE
3	79071376	1	50T	PLUG	TAPPO
4	79071375	1	50T	PLUG	TAPPO
5	79071372	1	100M	SPRING	MOLLA
6	79071400	1	2K	KIT	KIT
7	79082105	1	16A	SHAFT	ALBERO
8	79077602	1	10V	VALVE	VALVOLA
9	79071380	1	122G	SEAL	GUARNIZIONE
10	79077601	1	169R	REGULATOR	REGOLATORE
11	79082107	1	100M	SPRING	MOLLA
12	79074027	1	35S	CASE	SCATOLA

4807436
 INJECTION PUMP - FOMPA INIEZIONE - POMPE D'INJECTION - EINSPIRITZPUMPE - BOMBA DE INYECCION

A2.27/A 1

N.T.R. 200 - 15.10.1990

604.01.081.05

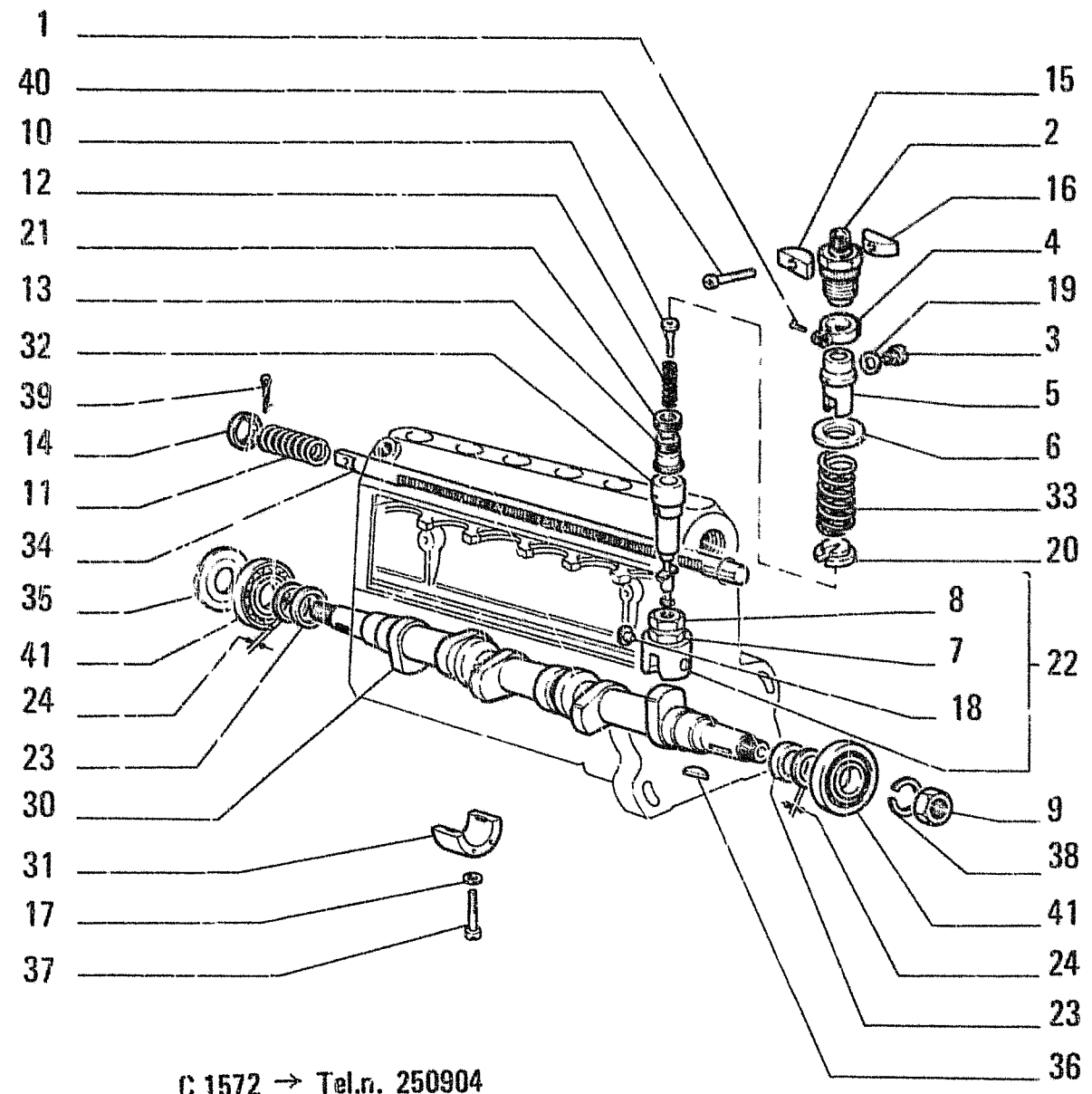

C 1572 → Tel.n. 250904

FIATALLIS FD7

ITEM	PART NUMBER	QTY	TRANS CODE	DESCRIPTION	DESCRIZIONE
24	765070		198S	SHIM 0,18	SPESSORE 0,18
	765071		198S	SHIM 0,20	SPESSORE 0,20
30	765304	1	16A	SHAFT	ALBERO
31	765306	1	341C	BEARING	CUSCINETTO
32	765461	6	164C	CYLINDER	CILINDRO
33	766419	6	100M	SPRING	MOLLA
34	767023	1	88A	ADJUSTING ROD	ASTA DI REGOLAZIONE
35	770785	1	131R	WASHER	ROSETTA
36	10206220	1	60L	KEY 6,5x3	LINGUETTA 6,5x3
37	10390811	2	40V	SCREW 5x0,8x30	VITE 5x0,8x30
38	10517070	1	132R	LOCKWASHER 12,2x3,1	ROSETTA DI SICUREZZA 12,2x3,1
39	10734301	1	270C	COTTER PIN 1,7x24,5	COPIGLIA 1,7x24,5
40	13276801	3	40V	SCREW 6x1x30	VITE 6x1x30
41	26799910	2	341C	BEARING 17x40	CUSCINETTO 17x40

INJECTION PUMP — POMPA INIEZIONE — POMPE D'INJECTION — EINSPRITZPUMPE — BOMBA DE INYECCIÓN

A2.27 2
 N.T.R. 191 - 20.02.1990
 604.01.081.04

M4

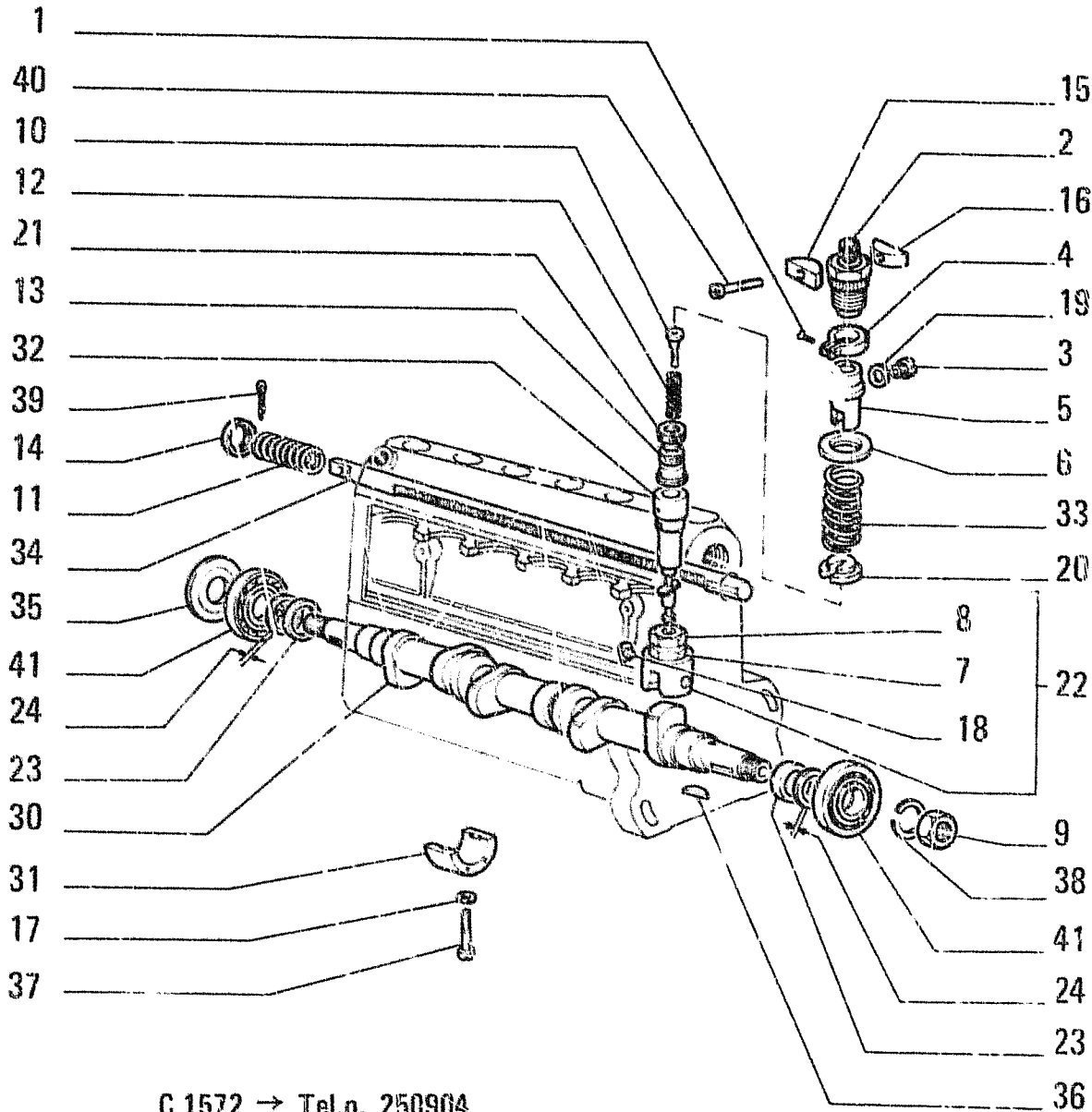

C 1572 → Tel.n. 250904

ITEM	PART NUMBER	QTY	TRANS CODE	DESCRIPTION	DESCRIZIONE
1	705816	6	40V	SCREW	VITE
2	746368	6	20R	FITTING	RACCORDO
3	746370	1	40V	SCREW	VITE
4	746371	6	135S	TOOTHED SECTOR	SETTORE DENTATO
5	746373	6	30M	SLEEVE	MANICOTTO
6	746374	6	120P	PLATE - UPPER	PIATTELLO - SUPERIOR
7	746379	1	10D	NUT	DADO
8	746380	1	40V	SCREW	VITE
9	746399	1	10D	NUT	DADO
10	748670	6	50T	PLUG	TAPPO
11	751627	1	100M	SPRING	MOLLA
12	754799	6	100M	SPRING	MOLLA
13	755703	6	10V	VALVE	VALVOLA
14	755860	1	60S	CUP	SCODELLINO
15	756190	3	78B	FASTENING BLOCK	BLOCCETTO DI FISSAGGIO
16	756191	3	78B	FASTENING BLOCK	BLOCCETTO DI FISSAGGIO
17	758707	2	133R	SEAL	ROSETTA DI TENUTA
18	760356	1	45P	PAD	PATTINO
19	760463	1	133R	SEAL	ROSETTA DI TENUTA
20	760489	6	120P	PLATE - LOWER	PIATTELLO - INFERIORE
21	760862	6	133R	SEAL	ROSETTA DI TENUTA
22	765057	6	240P	TAPPET - ASSEMBLY	PUNTERIA - COMPLETO
23	765065	2	45A	RING	ANELLO
24	765066		196S	SHIM 0,10	SPESORE 0,10
	765067		198S	SHIM 0,12	SPESORE 0,12
	765068		198S	SHIM 0,14	SPESORE 0,14
	765069		198S	SHIM 0,16	SPESORE 0,16

INJECTION PUMP - POMPA INIEZIONE - POMPE D'INJECTION - EINSPRITZPUMPE - BOMBA DE INYECCION

A2.27

2

N.T.R. 191 - 20.02.1990

604.01.051.04

M5

421

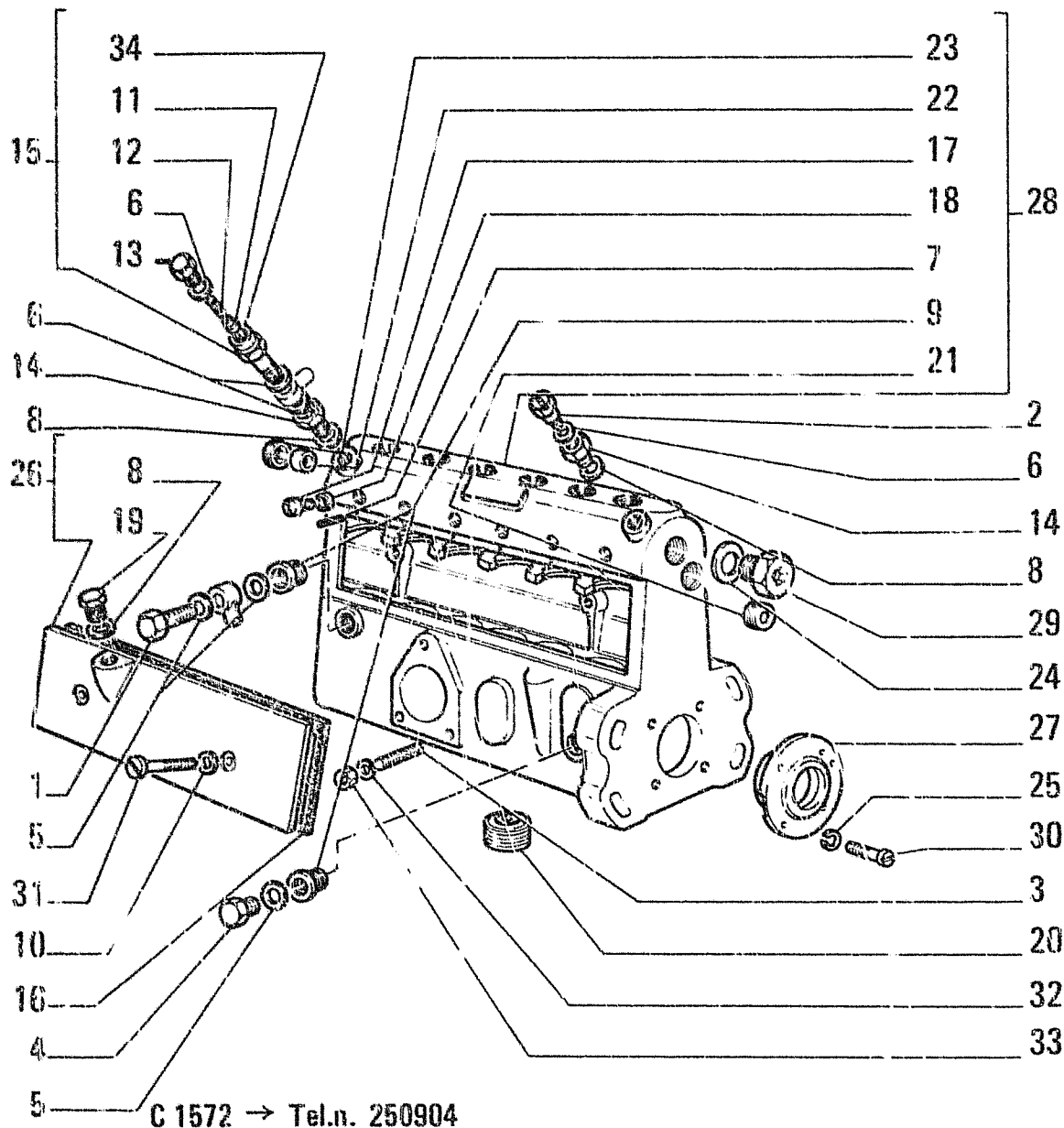

FIAT ALLIS FD7

A2.27 T.V. 1 PAG.2

ITEM	PART NUMBER	QTY	TRANS CODE	DESCRIPTION	DESCRIZIONE
28	771078	1	300C	BODY - ASSEMBLY	CORPO COMPLETO
29	10273101	1	50T	PLUG 18x1 5x10	TAPPO 18x1,5x10
30	10376711	4	40V	SCREW 6x1x16	VITE 6x1x16
31	10377611	2	40V	SCREW 6x1x50	VITE 6x1x50
32	10516470	3	132R	LOCKWASHER 6,1x1,8	ROSETTA DI SICUREZZA 6,1x1,8
33	15896211	3	10D	NUT 6x1x5	DADO 6x1x5
34	20419310	1	140S	BALL 15.082	SFERA 15.082

INJECTION PUMP - POMPA INIEZIONE - POMPE D'INJECTION - EINSPIRITZPUMPE - BOMBA DE INYECCION

M6

A2.27

1

N.T.R. 191 20.02.1990

604.01.081.04

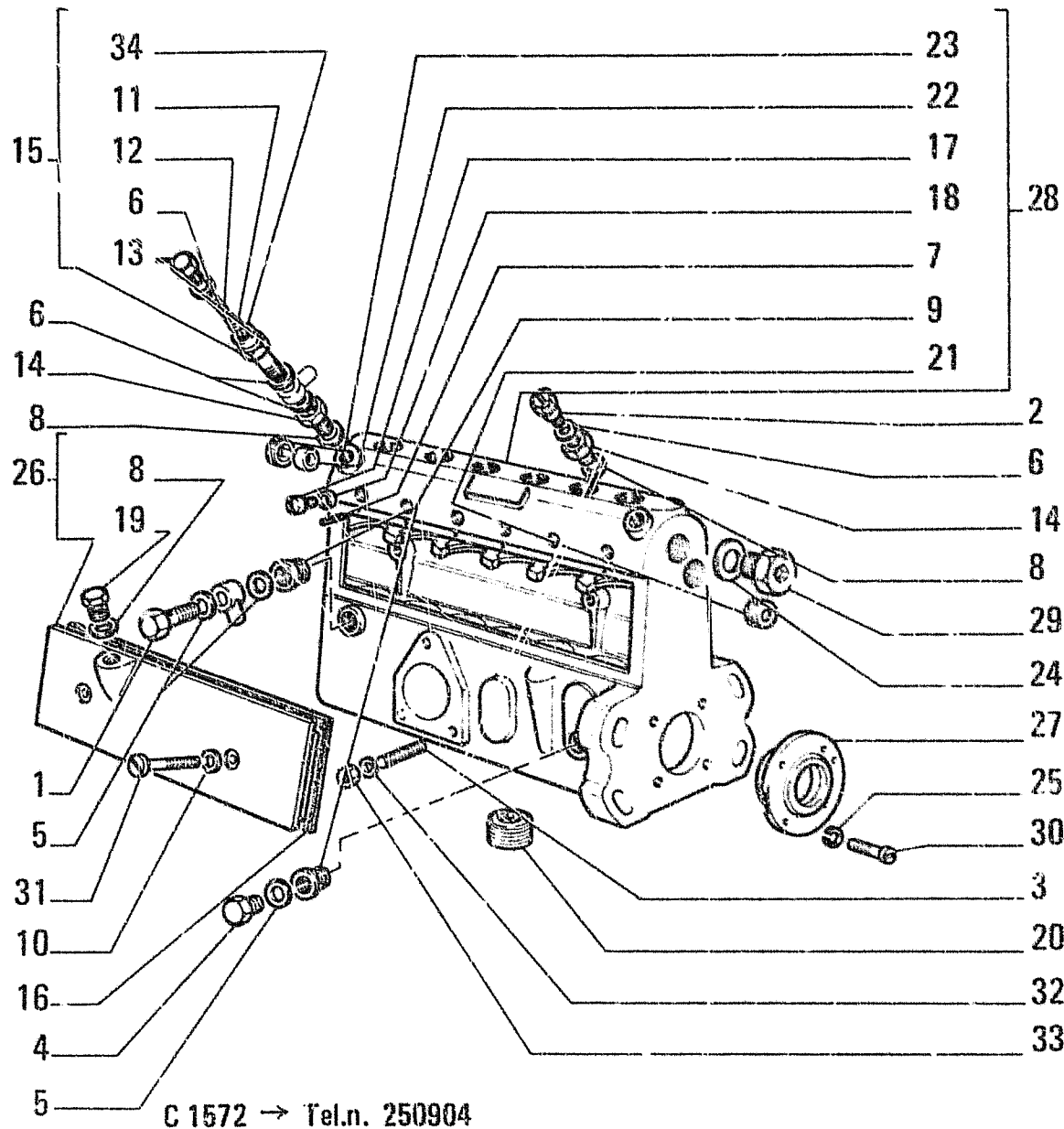

FIATALLIS FD7
A2.27 TAV. 1 PAG.1

I T E M	PART NUMBER	Q T Y	TRANS CODE	DESCRIPTION	DESCRIZIONE
1	705736	1	40V	SCREW	VITE
2	705737	1	40V	SCREW	VITE
3	11500210	3	40V	SCREW 6x1x25	VITE 6x1x25
4	726380	1	50T	PLUG	TAPPO
5	726381	3	133R	SEAL	ROSETTA DI TENUTA
6	746152	5	133R	SEAL	ROSETTA DI TENUTA
7	746366	6	200S	PIN	SPINA
8	746993	3	133R	SEAL	ROSETTA DI TENUTA
9	747568	2	20R	FITTING	RACCORDO
10	753177	2	133R	SEAL	ROSETTA DI TENUTA
11	756200	1	120P	PLATE	PIATTELLO
12	756201	1	100M	SPRING	MOLLA
13	756202	1	40V	SCREW	VITE
14	756203	2	99B	THREADED BUSH	BOCCOLA FILETTATA
15	758065	1	10V	VALVE - ASSEMBLY	VALVOLA - COMPLETO
16	759242	1	123G	SEAL ASSY	GUARNIZIONE TENUTA FRONTALE
17	764155	6	40V	SCREW	VITE
18	764995	6	133R	SEAL	ROSETTA DI TENUTA
19	765758	1	50T	PLUG	TAPPO
20	766250	6	50T	PLUG	TAPPO
21	772370	1	99B	THREADED BUSH	BOCCOLA FILETTATA
22	772379	2	95B	BUSHING	BOCCOLA
23	772381	1	45A	RING	ANFLLO
24	768043	1	133R	SEAL	ROSETTA DI TENUTA
25	768482	4	131R	WASHER	ROSETTA
26	769236	1	265C	COVER - ASSEMBLY	COPERCHIO COMPLETO
27	770784	1	265C	COVER	COPERCHIO

INJECTION PUMP - POMPA INIEZIONE - POMPE D'INJECTION - EINSPRITZPUMPE - BOMBA DE INYECCION

A2.27 1
 N.T.R. 191 - 20.02.1990
 604.01.081.04

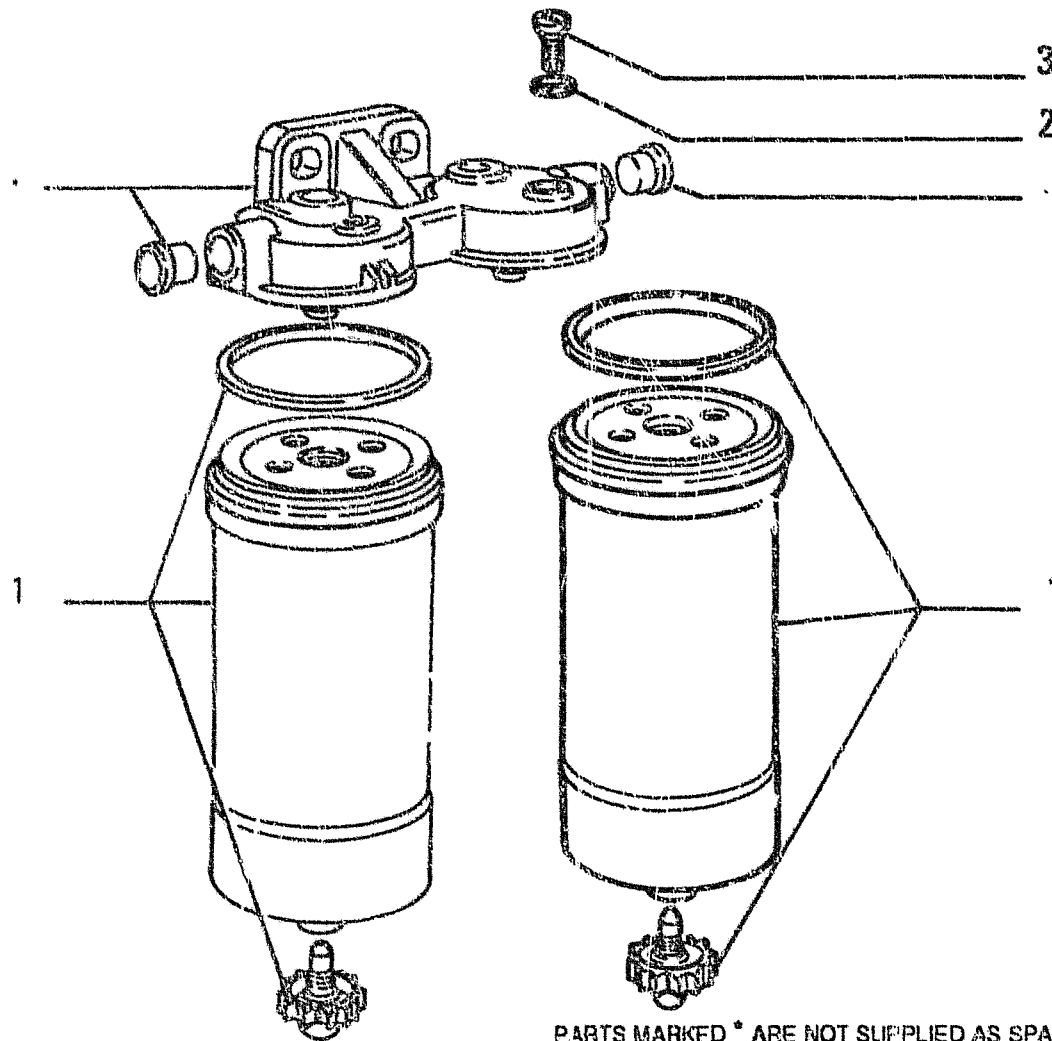
M7



ITEM	PART NUMBER	QTY	TRANS CODE	DESCRIPTION	DESCRIZIONE
1	4764725	2	84C	FILTERING ELEMENT	CARTUCCIA FILTRANTE
2	12648260	2	133R	SEAL	ROSETTA DI TENUTA
3	79069496	2	50T	PLUG	TAPPO

PARTS MARKED * ARE NOT SUPPLIED AS SPARES
 I PARTICOLARI CONTRASSEGNA TI CON * NON
 VENGONO FORNITI DI RICAMBIO

D 1572 Tel. n. 250905

4764724

FUEL FILTER — FILTRO COMBUSTIBILE — FILTRO DE COMBUSTIBLE — KRAFTSTOFFFILTER — FILTRO DE COMBUSTIBILE

A2.26 /A

N.T.R. 200 - 15.10.1990

604.01.081.05

M8

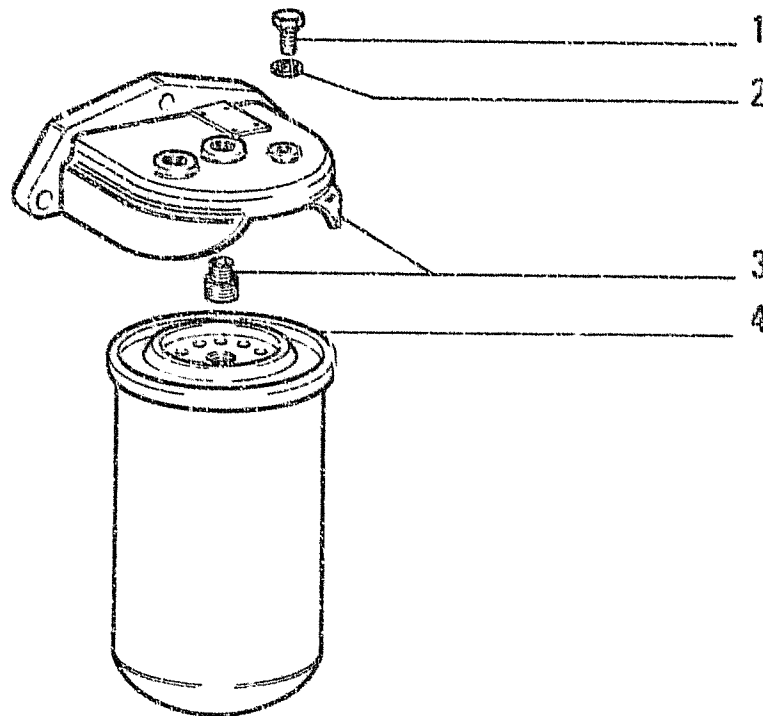

ITEM	PART NUMBER	QTY	TRANS CODE	DESCRIPTION	DESCRIZIONE
1	4626467	1	50T	PLUG	TAPPO
2	4626468	1	133R	SEAL	ROSETTA DI TENUTA
3	4640764	1	300C	BODY	CORPO
4	4742848	2	20E	FILTERING ELEMENT	ELEMENTO FILTRANTE

C 1572 → Tel.n. 250904

4618309

FUEL FILTER – FILTRO COMBUSTIBILE – FILTRE COMBUSTIBILE – KRAFTSTOFFFILTER – FILTRO DE COMBUSTIBILE

A2.26

N.T.R. 158 - 13.03.1987

604.01.081.03

M9

ITEM	PART NUMBER	QTY	TRANS CODE	DESCRIPTION	DESCRIZIONE
1	4757884	1	154P	FUEL PUMP	POMPA ALIMENTAZIONE

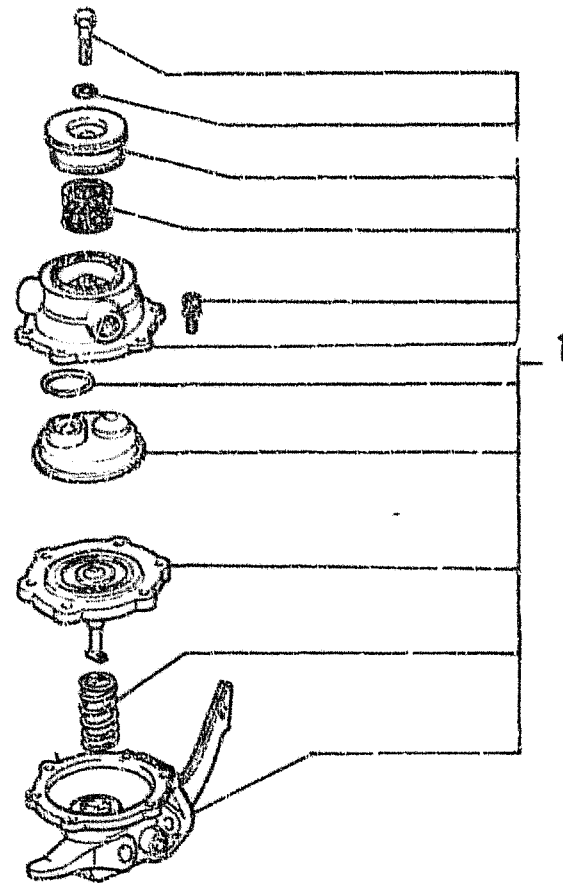

D 1572 Tel. n. 250905 →

4757884 (CORONA)

FUEL PUMP - POMPA ALIMENTAZIONE - POMPE D'ALIMENTATION - KRAFT STOFFPUMPE - BOMBA DE ALIMENTACION

A2.25/A

N.T.R. 158 - 13.03.1987
604.01.001.03

M10

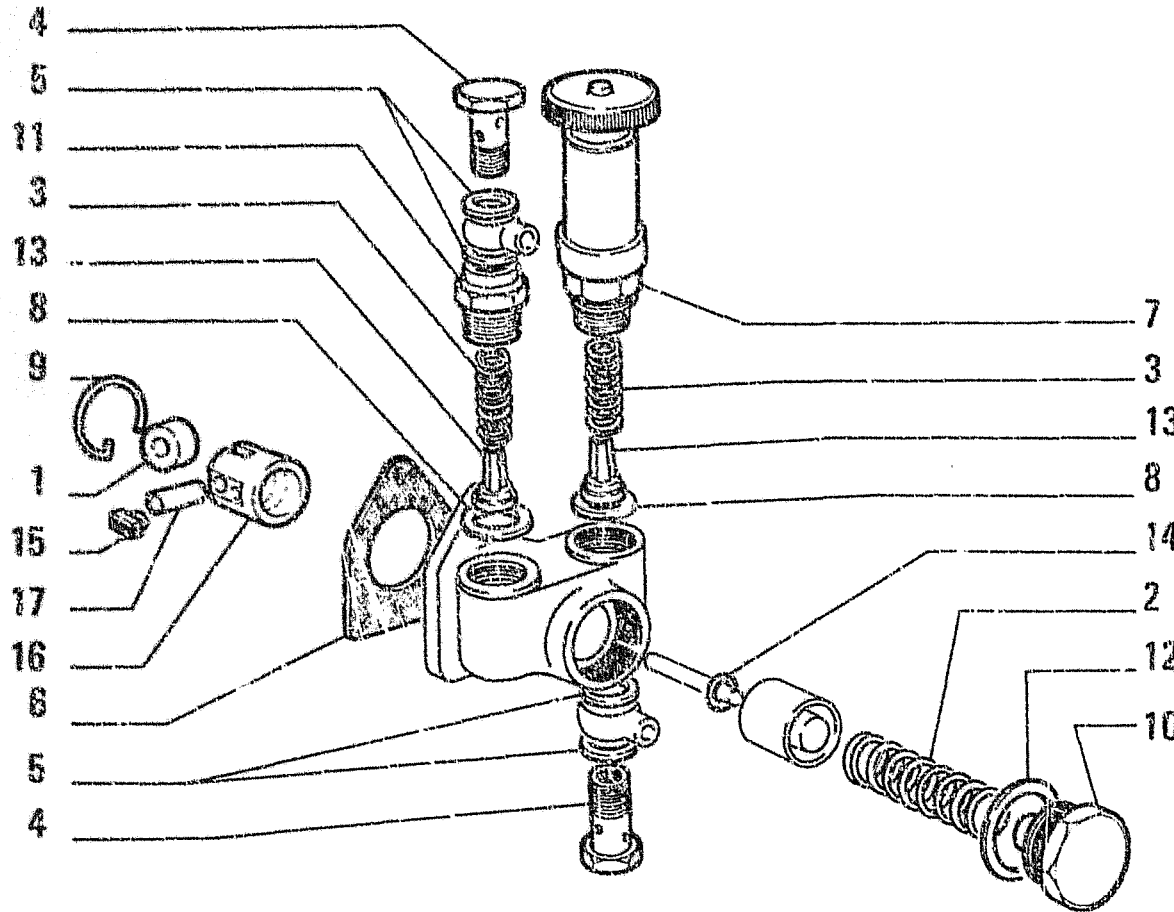

ITEM	PART NUMBER	QTY	TRANS CODE	DESCRIPTION	DESCRIZIONE
1	705639	1	157R	ROLLER	RULLO
2	705636	1	100M	SPRING	MOLLA
3	705637	2	100M	SPRING	MOLLA
4	705737	2	40V	SCREW	VITE
5	746152	4	133R	SEAL	ROSETTA DI TENUTA
6	746153	1	129G	SEAL ASSY	GUARNIZIONE TENUTA FRONTALE
7	746189	1	155P	PUMP	POMPA
8	746214	2	133R	SEAL	ROSETTA DI TENUTA
9	751032	1	51A	LOCKRING	ANELLO DI SICUREZZA
10	753762	1	50T	PLUG	TAPPO
11	760239	1	20R	FITTING	RACCORDO
12	760241	1	133R	SEAL	ROSETTA DI TENUTA
13	763178	2	10V	VALVE	VALVOLA
14	764120	1	158G	O-RING	GUARNIZIONE O-R
15	764956	2	45P	PAD	PATTINO
16	764957	1	241P	ROLLER TAPPET	PUNTERIA A RULLO
17	764958	1	80P	PIN	PERNO

C 1572 → Tel.n. 250904

767893

FUEL PUMP – POMPA ALIMENTAZIONE – POMPE D'ALIMENTATION – KRAFTSTOFFPUMPE – BOMBA DE ALIMENTACIÓN

A2.25

N.T.R. 158 - 13.03.1987
604.01.081.03

M11

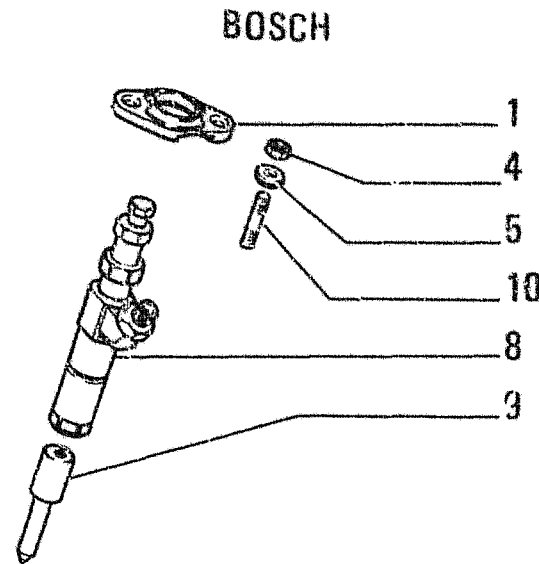
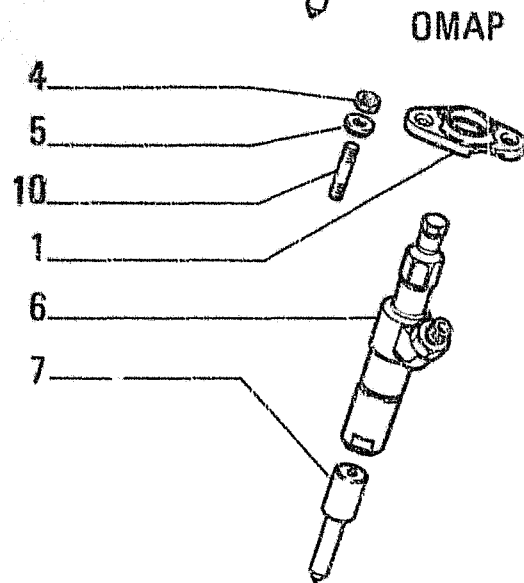
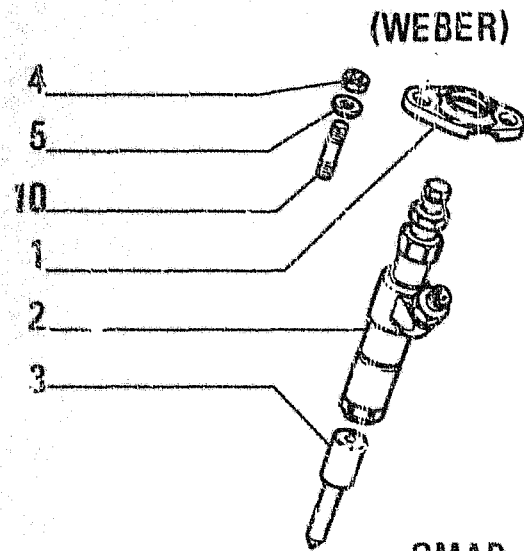

D 1572 Tel. n. 250905 →

ITEM	PART NUMBER	QTY	TRANS CODE	DESCRIPTION	DESCRIZIONE
1	4780612	6	225S	BRACKET	STAFFA
2	4802392	6	195P	NOZZLE HOLDER - ASSEMBLY IN ALTERNATIVE SEE SGR. A2.35/A	PORTAPOLVERIZZATORE - COMPLETO IN ALTERNATIVA VEDERE SGR. A2.35/A
3	4802395	6	148P	NOZZLE	POLVERIZZATORE
4	16100821	12	130D	NUT 8x1,25x6,5	DADO 8x1,25x6,5
5	771326	12	131R	WASHER	ROSETTA
6	79069718	6	195P	NOZZLE HOLDER - ASSEMBLY IN ALTERNATIVE SEE SGR. A2.35/2A	PORTAPOLVERIZZATORE - COMPLETO IN ALTERNATIVA VEDERE SGR. A2.35/2A
7	79069734	6	148P	NOZZLE	POLVERIZZATORE
8	4791124	6	195P	NOZZLE HOLDER - ASSEMBLY IN ALTERNATIVE SEE SGR. A2.35/1A	PORTAPOLVERIZZATORE - COMPLETO IN ALTERNATIVA VEDERE SGR. A2.35/1A
9	4800030	6	148P	NOZZLE	POLVERIZZATORE
10	13517530	12	210P	STUD 8x1,25x57	PRIGIONIERO 8x1,25x57

FUEL INJECTION SYSTEM - ALIMENTAZIONE AD INIEZIONE - ALIMENTATION PAR INJECTION -
EINSPRITZAUSRUESTUNG - ALIMENTACION POR INYECCION

A2.24/A

4

M.T.R. 158 - 13.03.1987
604.01.081.03

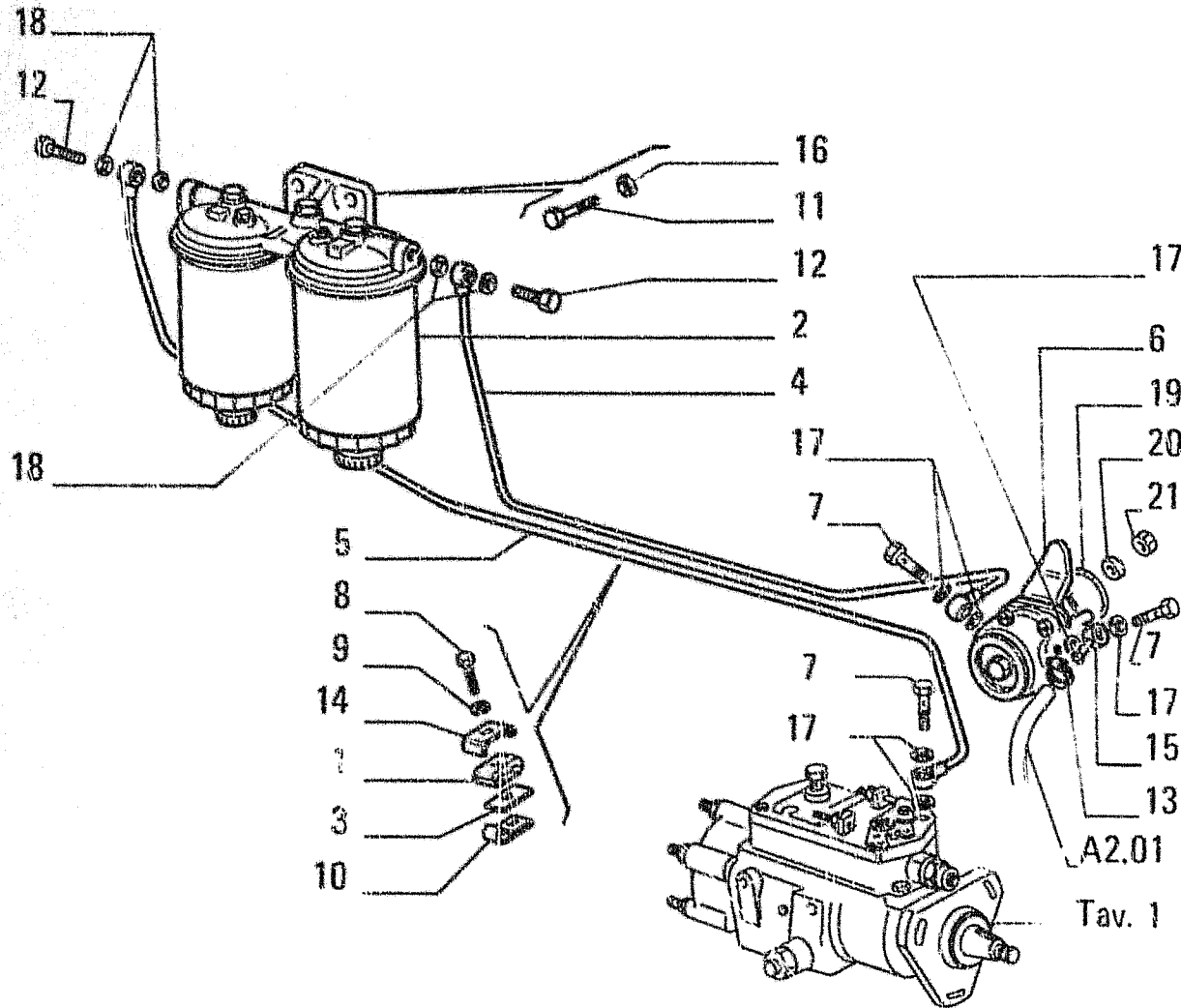

ITEM	PART NUMBER	QTY	TRANS CODE	DESCRIPTION	DESCRIZIONE
1	4659217	2	97S	HALF CONNECTOR	SEMIMORSETTO
2	4764724	1	64F	FUEL FILTER - ASSEMBLY SEE SGR A2.26/A	FILTRO COMBUSTIBILE - COMPLETO VEDERE SGR A2.26/A
3	4659219	2	300S	SUPPORT	SUPPORTO
4	4797579	1	193T	TUBE	TUBO RIGIDO
5	4797577	1	193T	TUBE	TUBO RIGIDO
6	4757884	1	154P	FUEL PUMP - ASSEMBLY SEE SGR A2.25/A	POMPA ALIMENTAZIONE - COMPLETO VEDERE SGR A2.25/A
7	10181711	3	90B	FILLER PLUG 12x1,5x23	BOCCHETTONE INTRODUZIONE 12x1,5x23
8	10978221	2	40V	SCREW 5x0,8x25	VITE 5x0,8x25
9	11195470	2	131R	WASHER 5,1x1,1	ROSETTA 5,1x1,1
10	10441390	2	231S	CLIP 12x7	STAFFETTA 12x7
11	11306924	2	40V	SCREW 10x1,25x30	VITE 10x1,25x30
12	10184311	2	90B	FILLER PLUG 14x1,5x27	BOCCHETTONE INTRODUZIONE 14x1,5x27
13	12174490	2	180C	COLLAR 92/112x14	COLLARE 92/112x14
14	4659218	2	97S	HALF CONNECTOR	SEMIMORSETTO
15	4790861	1	20R	FITTING	RACCORDO
16	11198371	2	131R	WASHER 10,5x20	ROSETTA 10,5x20
17	10296160	6	133R	SEAL 12,2x18	ROSETTA DI TENUTA 12,2x18
18	10280060	4	133R	SEAL 14,2x20	ROSETTA DI TENUTA 14,2x20
19	14458680	1	122G	SEAL 2,62x37,77	GUARNIZIONE 2,62x37,77
20	10519621	2	131R	WASHER 8,45x17	ROSETTA 8,45x17
21	16100821	2	10D	NUT 8x1,25x6,5	DADO 8x1,25x6,5

D 1572 Tel. n. 250905 --

FUEL INJECTION SYSTEM - ALIMENTAZIONE AD INIEZIONE - ALIMENTATION PAR INJECTION -
EINSPRITZAUSRUESTUNG - ALIMENTACIÓN POR INYECCIÓN

A2.24/A

3

N.T.F. 158 - 13.03.1987

604.01.081.03

PIATALLIS FD7

A2.24/ A TAV. 2 PAG.1

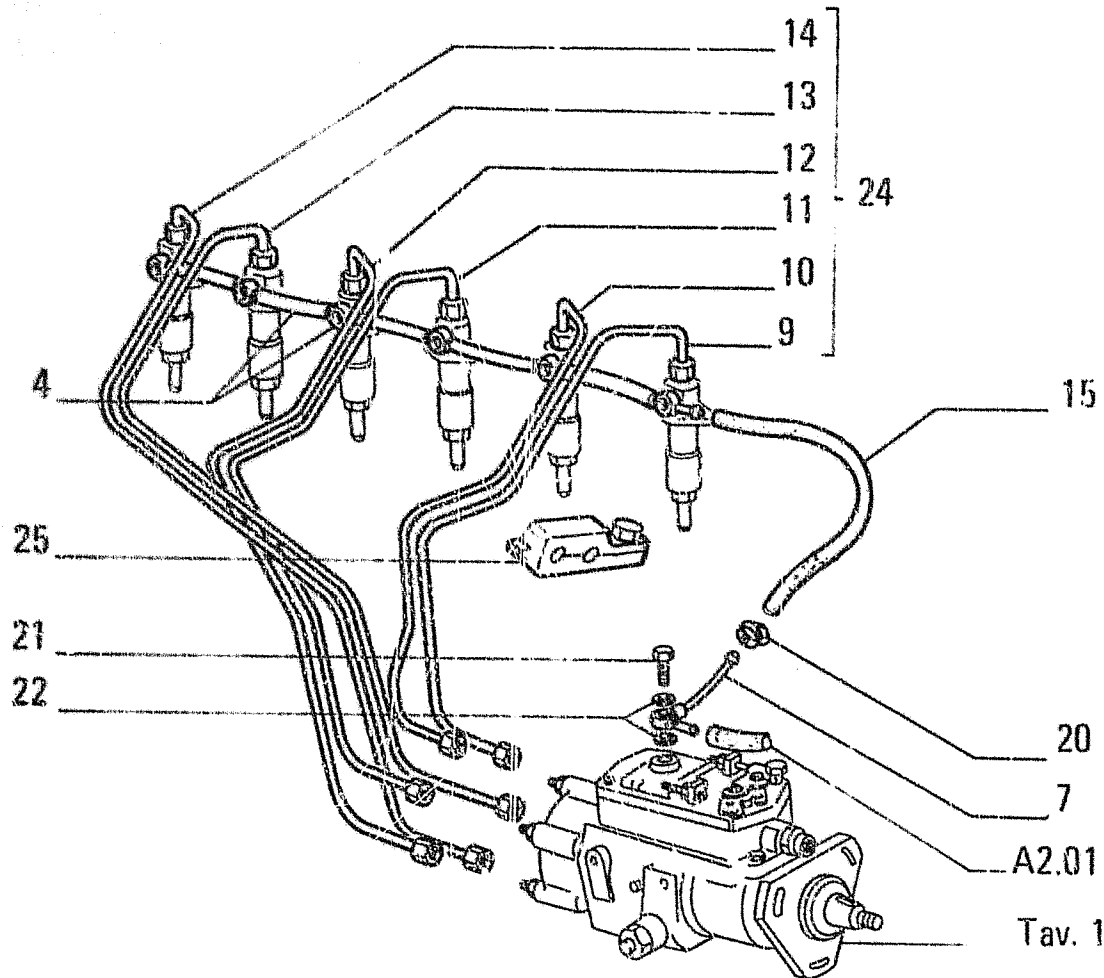

ITEM	PART NUMBER	QTY	TRANS CODE	DESCRIPTION	DESCRIZIONE
4	4770650	1	193T	TUBE	TUBO RIGIDO
7	4789560	1	193T	TUBE	TUBO RIGIDO
9	4792661	1	193T	TUBE N.1	TUBO RIGIDO N.1
10	4792662	1	193T	TUBE N.2	TUBO RIGIDO N.2
11	4792663	1	193T	TUBE N.3	TUBO RIGIDO N.3
12	4792664	1	193T	TUBE N.4	TUBO RIGIDO N.4
13	4792665	1	193T	TUBE N.5	TUBO RIGIDO N.5
14	4792666	1	193T	TUBE N.6	TUBO RIGIDO N.6
15	19053182	L	193T	HOSE ASSY 7x12	TUBO FLESS.C/RACCORDI 7x12
20	12179490	2	180A	COLLAR 9/16x8	COLLARE 9/16x8
21	10181711	1	90B	FILLER PLUG 12x1,6x23	BOCCHETTONE INTRODUZIONE 12x1,5x23
22	10296160	2	133R	SL.NL 12,2x18	ROSETTA DI TENUTA 12,2x18
24	4791125	1	193T	TUBE - ASSEMBLY	TUBO RIGIDO - COMPLETO
25	4806611	3	225S	BRACKET - ASSEMBLY	STAFFA - COMPLETO

D 1572 Tel. n. 250905 →

FUEL INJECTION SYSTEM — ALIMENTAZIONE AD INIEZIONE — ALIMENTATION PAR INJECTION —
EINSPRITZAUSRUESTUNG — ALIMENTACION POR INYECCION

A2.24/A

2

M.T.K. 158 - 13.03.1987

604.01.081.03

M14

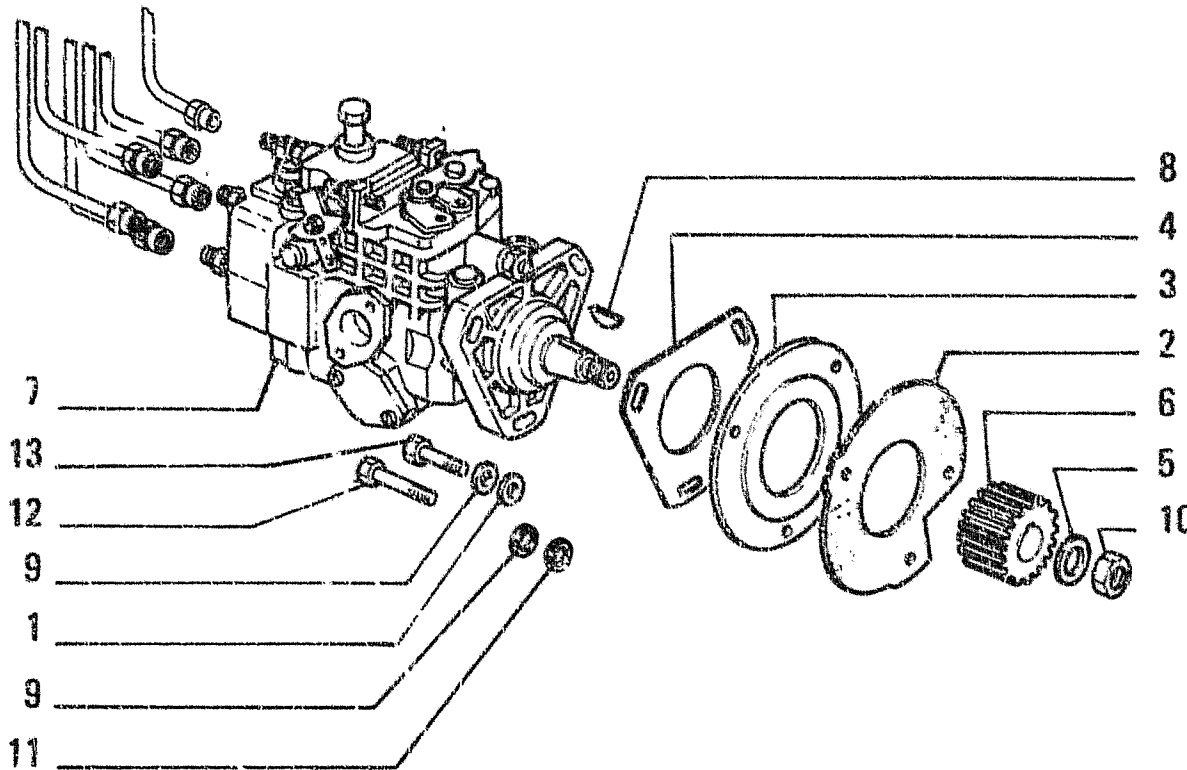

ITEM	PART NUMBER	QTY	TRANS CODE	DESCRIPTION	DESCRIZIONE
1	4564844	3	132R	LOCKWASHER	ROSETTA DI SICUREZZA
2	4791332	1	120G	GASKET	GUARNIZIONE PIANA
3	4799016	1	75D	SPACER	DISTANZIALE
4	4799060	1	120G	GASKET	GUARNIZIONE PIANA
5	4799086	1	132R	LOCKWASHER	ROSETTA DI SICUREZZA
6	4799342	1	95B	BUSHING	BOCCOLA
7	4807436	1	109G	INJECTION EQUIPMENT - SEE SGR. A2.27/A	GRUPPO INIEZIONE - VEDERE SGR. A2.27/A
8	10205820	1	60L	KEY 6,5x4	LINGUETTA 6,5x4
9	11193871	6	132R	LOCKWASHER 8,4x16	ROSETTA DI SICUREZZA 8,4x16
10	12164011	1	10D	NUT 14x1,5x11	DADO 14x1,5x11
11	12647101	3	132R	LOCKWASHER	ROSETTA DI SICUREZZA
12	16043824	3	40V	SCREW 8x1,25x30	VITE 8x1,25x30
13	16043924	3	40V	SCREW 8x1,25x35	VITE 8x1,25x35

D 1572 Tel. n. 250905

INJECTION PUMP - POMPA INIEZIONE - POMPE D'INJECTION - EINSPRITZPUMPE - BOMBA DE INYECCION

A2.24/A

1

N.T.R. 158 - 13.03.1987

604.01.081.03

M15

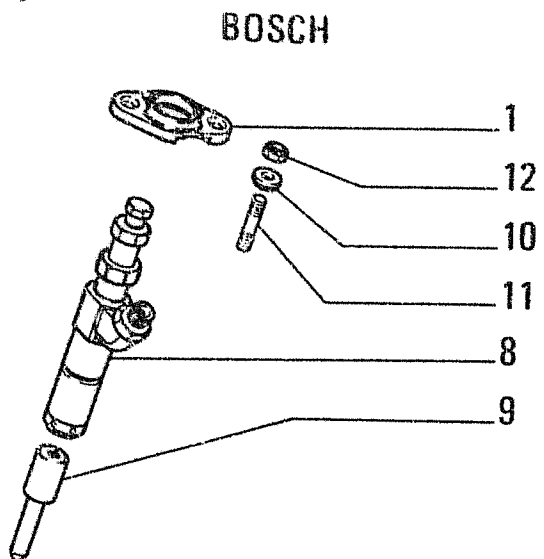
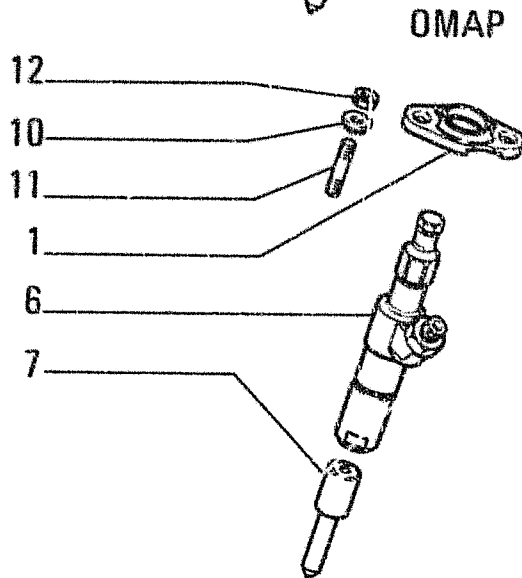
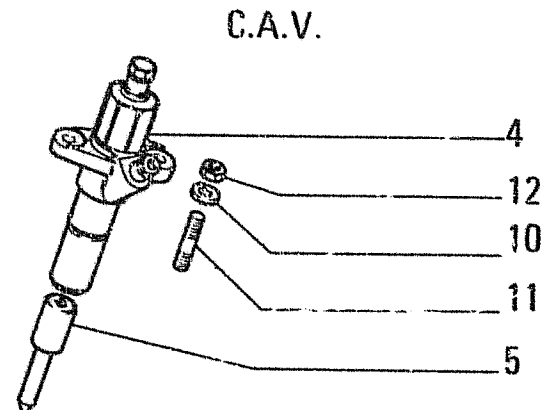
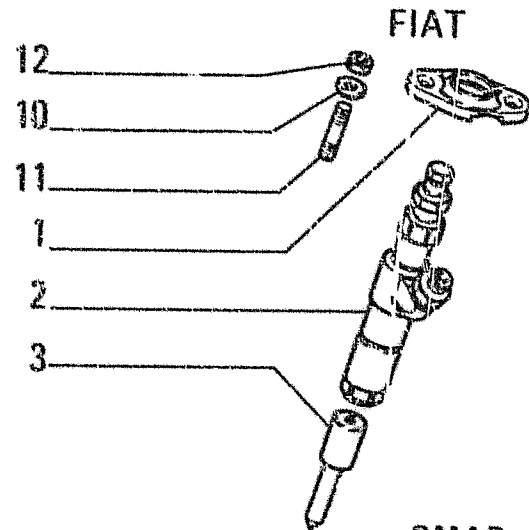

C 1572 → Tel.n. 250904

ITEM	PART NUMBER	QTY	TRANS CODE	DESCRIPTION	DESCRIZIONE
1	765640	6	231S	CLIP	STAFFETTA
2	767107	6	195P	NOZZLE HOLDER - ASSEMBLY IN ALTERNATIVE SEE SGR. A2.35	PORTAPOLVERIZZATORE - COMPLETO IN ALTERNATIVA VEDERE SGR. A2.35
3	770578	6	148P	NOZZLE	POLVERIZZATORE
4	770899	6	195P	NOZZLE HOLDER - ASSEMBLY IN ALTERNATIVE SEE SGR. A2.35/1	PORTAPOLVERIZZATORE - COMPLETO IN ALTERNATIVA VEDERE SGR. A2.35/1
5	770902	6	148P	NOZZLE	POLVERIZZATORE
6	770958	6	195P	NOZZLE HOLDER - ASSEMBLY IN ALTERNATIVE SEE SGR. A2.35/2	PORTAPOLVERIZZATORE - COMPLETO IN ALTERNATIVA VEDERE SGR. A2.35/2
7	770959	6	148P	NOZZLE	POLVERIZZATORE
8	771065	6	195P	NOZZLE HOLDER - ASSEMBLY IN ALTERNATIVE SEE SGR. A2.35/3	PORTAPOLVERIZZATORE - COMPLETO IN ALTERNATIVA VEDERE SGR. A2.35/3
9	771066	6	148P	NOZZLE	POLVERIZZATORE
10	771326	12	131R	WASHER	ROSETTA
11	13517630	12	210P	STUD 8x1,25x62	PRIGIONIERO 8x1,25x62
12	16100821	12	10D	NUT 8x1,25x6,5	DADO 8x1,25x6,5

FUEL INJECTION SYSTEM - ALIMENTAZIONE AD INIEZIONE - ALIMENTATION PAR INJECTION
EINSPRITZAUSRUESTUNG - ALIMENTACION POR INYECCION

A2.24

4

N.T.R. 158 - 13.03.1987

604.01.081.03

M16

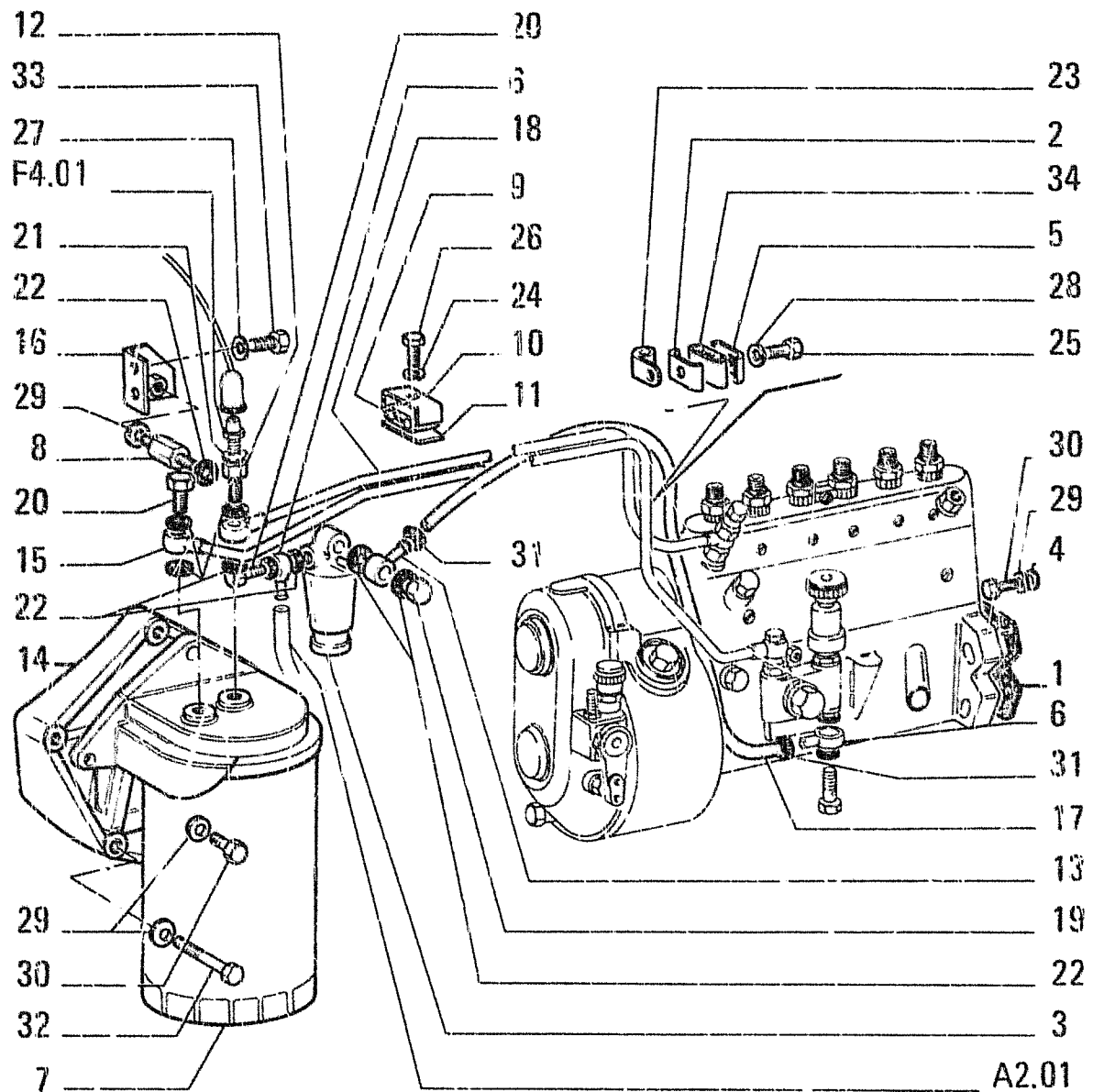

C 1572 → Tel.n. 250904

FIATALLIS FD7

ITEM	PART NUMBER	QTY	TRANS CODE	DESCRIPTION	DESCRIZIONE
25	10902221	1	40V	SCREW 6x1x16	VITE 6x1x16
26	10978221	1	40V	SCREW 5x0,8x25	VITE 5x0,8x25
27	11193871	2	132R	LOCKWASHER 8,4x16	ROSETTA DI SICUREZZA 8,4x16
28	11197771	1	132R	LOCKWASHER 6,4x12	ROSETTA DI SICUREZZA 6,4x12
29	11198371	11	132R	LOCKWASHER 10,5x20	ROSETTA DI SICUREZZA 10,5x20
30	11307021	7	40V	SCREW 10x1,25x40	VITE 10x1,25x40
31	12179490	2	180C	COLLAR 9/16x1	COLLARE 9/16x8
32	15971521	3	40V	SCREW 10x1,25x85	VITE 10x1,25x85
33	16043221	2	40V	SCREW 8x1,25x16	VITE 8x1,25x16
34	4592280	2	78B	FASTENING BLOCK	BLOCCHETTO DI FISSAGGIO

FUEL INJECTION SYSTEM — ALIMENTAZIONE AD INIEZIONE — ALIMENTATION PAR INJECTION —
 EINSPRITZAUSRUESTUNG — ALIMENTACION POR INYECCION

A2.24 3

N.T.R. 230 - 15.10.1990

604.01.081.05

DESIGNAZIONE BASE	BASIC DESIGNATION	DESIGNATIONS-BASES	GRUNDBEZEICHNUNGEN	DENOMINACIONES BASE	
168T	TRASPARENTE DELL'INDICATORE DI DIREZIONE	DIRECTION INDICATOR LAMP LENS	TRANSPARENT D'INDICATEUR DE DIRECTION	LICHTSCHEIBE DER BLINKLEUCHTE	TAPA TRANSLUCIDA DEL INDICADOR DE DIRECCION
168T					
169C	CILINDRO DI DISINNESTO	RELEASE CYLINDER	CYLINDRE DE DISAYAGE	ARBEITZSYLINDER	CILINDRO DE EMBRAGUE
169P	POMPETTA	PUMP WASHER	POMPE	PUMPE	BOMBA
169R	REGOLATORE	REGULATOR	REGULATEUR	REGLER	REGULADOR
169T	TRASPARENTE CON CATADIOTTRIO	LENS AND REFLEX-REFLECTOR	TRANSPARENT ET CATADIOPTRE	LICHTSCHEIBE MIT REFLEKSTRABLER	TAPA TRANSLUCIDA CON CATAFAROS
169T					
176A	RAFFREDDAMENTO MOTORE	ENGINE COOLING SYSTEM	REFROIDISSEMENT MOTEUR	LEITUNGEN MOTORKUEHL SYSTEM	
1762	TUBAZIONI RAFFREDD MOTORE	ENGINE COOLING PIPING		DICHTUNG FUER LUFTANLAGE	
1765	ELEMENTI TENUTA AR A	AIR-TIGHT ELEMENT	ELEMENTS ETANCHEITE D'AIRE	HAUPTZYLINDER	CILINDRO PRINCIPAL
170C	CILINDRO MAESTRO	MASTER CYLINDER	MAITRE-CYLINDRE	ANHAENGERKUPPLUNG	BRIDA
170P	PONTICELLO	BRIDGE PIECE	CHAPE D'ATTELAGE	FEDERBRING	ARANDELA DE FRENO
170R	ROSETTA EL.	LOCKWASHER	RONDELLE A RESORT	ENTSTOERER	SUPRESOR
170S	SOPPRESSORE	SUPPRESSOR	RESISTANCE	LICHTSCHEIBE	TRANSLUCIDO
170T	TRASPARENTE	LENS	TRANSPARENT	ZYLINDER	CILINDRO DE MANDO
171C	CILINDRO OPERATORE	OPERATING CYLINDER	CYLINDRE DE COMMANDE		
171C					
171R	RIFLETTORE	REFLECTOR	REFLECTEUR	REFLEKTOR	REFLECTOR
171S	SOPRASUOLA	STREET PLATE	PATIN DE ROUTE	STRASSENSCHUH	PATIN DE CARRETERA
172C	CINGHIA DI FISSAGGIO	SECURING STRAP	SANGLE DE FIXATION	HALTERIEMEN	CORREA DE FIJACION
172S	SOSPENSIONE	SUSPENSION	SUSPENSION	AUFHAENGUNG	SUSPENSION
173C	CINGHIA	BELT	COURROIE	KEILRIEMEN	CORREA
173R	RALLA ROTAZIONE	BULL GEAR	CRAPAUDINE	DREHKRANZ	RUEDA DE DIENTES-EXCAVADORA
174C	CINGHIE	BELTS	COURROIES	RIEMEN	CORREAS
174R	RALLA PORTALAMA	CIRCLE	CERCLE	KUGELAUFNAHME	RUEDA DE DIENTES-MOTONIVELADOR
174S	SOSTERNO	BRACE	SUPPORT	STUETZE	SOPORTE
175R	REGOLATORE MECCANICO	GOVERNOR	REGULATEUR	MECHANISCHER REGLER	REGULADOR
176C	COFANO	HOOD	CAPOT	MOTORHAUBE	CAPOT
176R	RUSPA	SCRAPER	DECROTTOIR	ABSTREICHER	LIMPIADOR
177R	RUOTA COMPATTATORE	PADFOOT WHEEL			
177S	SPAZZOLA	BRUSH	BALAI	KOHLENBUERSTE	ESCOBILLA
178C	CINGOLO	TRACK	CHENILLE	RAUPENKETTE	ORUGA
180C	COLLARE	COLLAR	COLLIER	ROHRSCHELLE	COLLAR
180P	PORTA	DOOR	PORTE	TUER	PUERTA
180T	TRAVERSA	CROSS BEAM	TRAVERSE	TRAVERSE	TRAVESANO
181T	TRAVERSA DI TRAINO	DRAWBAR FRAME	TRAVERSE D'ATTELAGE	ACKERSCHIENE	TRAVIESA PERFORADA
181T					
182C	CINTURA DI SICUREZZA	SAFETY BELT	CINTURE DE SECURITE	SICHERHEITSGURT	CINTURON DE SEGURIDAD

DESIGNAZIONE BASE	BASIC DESIGNATION	DESIGNATIONS-BASES	GRUNDBEZEICHNUNGEN	DENOMINACIONES BASE	
182I	SOLLEVATORE IDRAULICO (VELOCE)		RELEVAGE HYDRAULIQUE (RAPIDE)	KRAFTHEBER HYDRAULISCH-SCHNELL	
183I	PORTACENERE	ASHTRAY	CENDRIER	ASCHENFACHER	CENICERO
184L	COLONNETTA	STUD	COLONNETTE	SCHRAUBENBOLZEN	COLUMNIA
184S	SPECCHIO	MIRROR	MIROIR	SPIEGEL	ESPEJO
185C	CHIODO	NAIL	CLOU	NIET	CLAVO
185P	PORTACONTATTI	CONTACT CARRIER	PORTE-CONTACTS	KLEMMENHALTER	CAJA DE BORNAS
185S	SPECCHIO RETROVISORE	REAR VIEW MIRROR	RETROVISEUR	RUECKSPIEGEL	ESPEJO RETROVISOR
186A	ALBERO RETROMARCIA	REVERSE SHAFT	ARBRE ARRIERE	WELLE-RUECKWAERTSGANG	ARBOL MARCHA ATRAS
187A	ANELLO ELASTICO	SNAP RING	ARRETOIR	SPANNRING	AROS ELASTICOS
187C	COMANDO CADUTA LIBERA DI EMERGENZA	FREE FALL CONTROL	COMMANDE DE CHUTE	NOTSTEUERUNG DES F	MANDO DE CAIDA LIB EMERGENCIA
187C			GENCE		
188A	APPENDIABITI	COAT-HOOK	PORTEMANTEAUX	KLEIDERHAKEN	COLGADOR
188C	COLLETTORE	MANIFOLD	COLLECTEUR	KRUEMMER	COLECTOR
188P	PORTAFUSIBILE	FUSE HOLDER	PORTE-FUSIBLE	SICHERUNGSSHALTER	PORTAFUSIBILE
189A	ATTUATORE DI ROTAZIONE	SLEWING ACTUATOR	GROUPE DE ROTATION	DREHAGGREGAT	MECANISMO DE ROTACION
189C	COMANDO	CONTROL	COMMANDE	BETAETIGUNGS-VORRICHT	MANDO
189C					
19G7	TUBAZIONI MOTORE-FILTRO ARIA	ENGINE TO AIR CLEANER LINES		LEITUNGEN FUER MOTORLUFTFILTER	
19QA	ARRICCHITORE	EXCESS FUEL	DISPOSITIF CONTROLE	MEHRMENGENSYSTEM	SUPLEMENTO DE INYECCION
19QA			INTRODUCTION		
19CC	COMANDO A MANO	HAND CONTROL	COMMANDE A MAIN	HANDBETAETIGUNG	MANDO MANJAL
19OS	SPECIALE PER RICAMBI	SPECIFIC FOR REPLACEMENTS	SPECIAL POUR	EXTRA FUER DEN	ESPECIAL PARA RE-
19OS			RECHANGES	ERSATZ	CAMBIOS
190T	TUBAZIONE	LINE	TUYAU	LEITUNG	TUBO
191C	COMANDO A PEDALE	FOOT CONTROL	COMMANDE AU PIED	FUSSHEBEL	PEDAL
192C	COMANDO DELL'AVVISATORE	HORN BUTTON	COMMANDE D'AVERTISSEUR	HORN/BETAETIGUNG	PULSADOR DE BOCINA
192C					
192P	PORTAOGGETTI	UTILITY HOLDER	PORTE-OBJETS	ABLAGE	PORTAOBJETOS
192T	TUBO FLESSIBILE/RACCORDI	HOSE ASSY	TUYAU FLEXIBLE	SCHLAUCH MIT STUTZEN	TUBO FLEXIBLE
193C	COMANDO PNEUMATICO	AIR CONTROL	COMMANDE PNEUMATIQUE	PNEUMAT BETAETIGUNG	MANDO NEUMATICO
193C					
193P	PORTALAMPADA	BULB HOLDER	PORTE-LAMPE	LAMPENFASSUNG	SOPORTE DE LAMPARA
193T	TUBO RIGIDO	TUBE	TUYAU	ROHR	TUBO
194C	COMANDO ELETTROPNEUMATICO	ELECTRO-PNEUMATIC CONTROL	COMMANDE ELECTRO-PNEUMATIQUE	ELEKTROPNEUMATISCHE BETAETIGUNG	MANDO ELECTRO-NEUMATICO
194C					
195C	COMANDO FLESSIBILE	BOWDEN ASSY.	TIRETTE DE COMMANDE	BOWDENZUG	MANDO FLEXIBLE
195C					
195P	PORTAPOLVERIZZATORE	NOZZLE HOLDER	PORTE-PULVERISATEUR	DUESENSTOCK	PORTAINYECTOR
195T	TUBETTO	TUBE	TUBE	ROHR	TUBO
196P	PORTASATELLITI	PLANETARY HUB	PORTE SATELLITES	PLANETENTRAEGER	EJE DE SATELITES

	DESIGNAZIONE BASE	BASIC DESIGNATION	DESIGNATIONS-BASES	GRUNDBEZEICHNUNGEN	DENOMINACIONES BASE
196S	SPERONE	TRACK FRAME END	GUIDE CHENILLES	KETTENFUERHRUNG	ESPOLON
196T	TUBETTO ISOLANTE	INSULATING SHEAT	TUBE ISOLANT	ISOLIERHUELLE	TUBO AISLANTE
197C	COMANDO ACCELERATORE	THROTTLE CONTROL	COMMANDE D'ACCELERATEUR	GASREGULIERUNG	MANDO DEL ACELERADOR
197P	PORTASPAZZOLA	BRUSH HOLDER	PORTE-BALAI	BUERSTENTRAEGER	PORTAESCOBILLA
197S	SPESSORE ELASTICO	PAD	CALE ELASTIQUE	ELASTISCHE UNTER- LAGE	SUPLEMENTO ELA- STICO
197S				HUELSE	TUBITO DE FIJACION
197T	TUBETTO STRINGIFILO	FERRULE	TUBE D'ATTACHE	STARTVORRICHTUNG	MANDO MANUAL DE STARTER
198C	COMANDO A MAND STARTER	CHOKE CONTROL	COMMANDE A MAIN DE STARTER		SOPORTE DE PLACA
198C					ESPESOR
198P	PIASTRA PORTATARGA	PLATE SUPPORT	PORTE-PLAQUE	KENNZEICHENWALTER	CUCHILLA
198S	SPESSORE	SHIM	CALE D'EPARGSEUR	DISTANZSCHEIBE	CALIBRE
199C	COITELLO SENNA	BUCKET CUTTING EDGE	COUTEAU /AU GODET	SCHWEIDE	PESTILLO DE SEGU- RIDAD
199S	SPISSIMETRO	FEELER GAUGE	JAUGE D'EPAISSEUR	DICKENMESSGERAET	ELEMENTO SEPARADOR
200C	COMANDO SICUREZZA	SAFETY CONTROL	COMMANDE DE SECU- RITE	INNENSICHERUNG	PASADOR
200C					CUELLO DE CARGA
200P	PIEMIGUARNIZIONE	EXPANDER	PRESSE-JOINT	DRUCKFEDER	
200S	SPINA	PIN	GOUPILLE	STIFT	
200T	TUBO DI INTRODUZIONE	FILLER TUBE	TUBULURE DE REM- PLISSAGE	EINFUELLSTUTZEN	
200T					
200V	VALVOLA AUTOMATICA DI SCARICO	AUTOMATIC DRAIN VALVE	SOUPAPE AUTOMATI- QUE DE DETENTE	AUTOMATISCHES AUSLASSVENTIL	VALVULA DE DESCAR- GA AUTOMATICA
200V					PREFILTRO
201P	PREFILTRO	PRECLEANER	PREFILTRE	VORABSCHIEDER	ENCHUFE
201S	SPINA ELETTRICA	ELECTRICAL PLUG	FICHE ELECTRIQUE	STECKER	VALVULA DE PURGA
201V	VALVOLA AUTOMATICA DI SPURGO	AUTOMATIC BLEED VALVE	PURGEUR AUTOMATI- QUE	AUTOMATISCHES AUSLASSVENTIL	AUTOMATICA
201V				ZUENDANLASSCHALTER	CONMUTADOR CON
202C	COMMUTATORE CON ANTIFURTO	KEY SWITCH W/ANTI-THEFT DEVICE	COMMUTATEUR AVEC ANTIVOL	MIT LENKSCHLOSS	DISP. ANTIRROBO
202C				RUECKSTELLVORRICHTUNG	POSICIONADOR
202P	POSIZIONATORE	POSITIONER	POSITIONNEUR	SPANNSTIFT	PASADOR ELASTICO
202S	SPINA ELASTICA	SPRING PIN	GOUPILLE ELASTIQUE	BORDWAND	LADO
202S	SPONDA	SIDE	RIDELLE	ZURUFREVENTIL	VALVULA DE ALI- MENTACION
203V	VALVOLA DI ALIMENTAZIONE	FEED VALVE	SOUPAPE D'ALIMEN- TATION	LUFTANSCHLUSS	BOCA DE AIRE
203V				STECKDOSE	TOMA DE CORRIENTE
204P	PRESA ARIA	AIR INTAKE	PRISE D'AIR	KLAPPE	POSTIGO
205P	PRESA DI CORRENTE	RECEPTACLE	PRISE DE COURANT	ZAPFWELLE	TOMA DE FUERZA
205S	SPORTELLO	DOOR	VOLET	ENTLUEFTUNGSLEI- TUNG	TUBO DE VENTILA- CION
207P	PRESA DI FORZA	POWER TAKE-OFF	PRISE DE FORCE	TURBINE	TURBINA
207T	TUBO DI SFIATO	VENT PIPE	TUBE D'EVENT		
207T					
209T	TURBINA	TURBINE	TURBINE		
21G3	ARTICOLAZIONE TELAI	MAIN FRAME ARTICULATION	ARTICULATION DES CHASSIS		

A

ENGINE • MOTORE • MOTEUR • MOTOR • MOTOR

N1

PARTS MARKED * ARE NOT SUPPLIED AS SPARES
 I PARTICOLARI CONTRASSEGNA TI CON * NON
 VENGONO FORNITI DI RICAMBIO

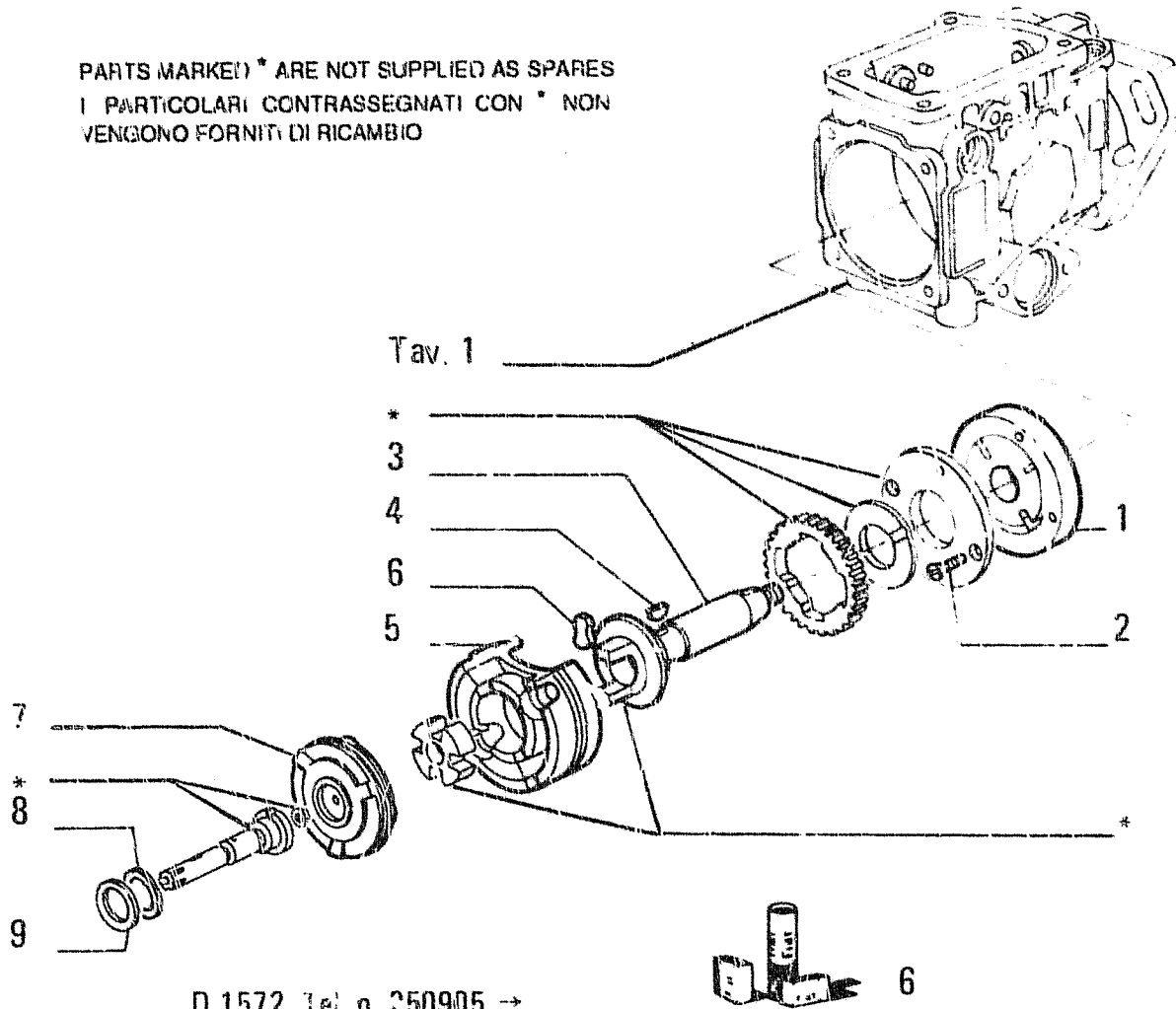

D 1572 Tel. n. 250905 →



FIATALLIS FD7

A2.27/ A TAV. 3 PAG.1

ITEM	PART NUMBER	QTY	TRANS CODE	DESCRIPTION	DESCRIZIONE
1	79082106	1	16/P PUMP		POMPA
2	13297921	2	40 / SCREW		VITE
3	79071383	1	16A SHAFT		ALBERO
4	79071384	1	6JL KEY		LINGUETTA
5	79071385	1	300S SUPPORT		SUPPORTO
6	79071400	1	2K KIT		KIT
7	79071386	1	60D DISC		DISCO
8	79071387	1	131R WASHER		ROSETTA
9	79071388	1	131R WASHER		ROSETTA

4807436

INJECTION PUMP — POMPA INIEZIONE — POMPE D'INJECTION — EINSPRITZPUMPE — BOMBA DE INYECCION

A2.27/A

3

N.T.R. 200 - 15.10.1990

604.01.081.05

N2

PARTS MARKED * ARE NOT SUPPLIED AS SPARES
 I PARTICOLARI CONTRASSEGNA TI CON * NON
 V NGONO FORNITI DI RICAMBIO

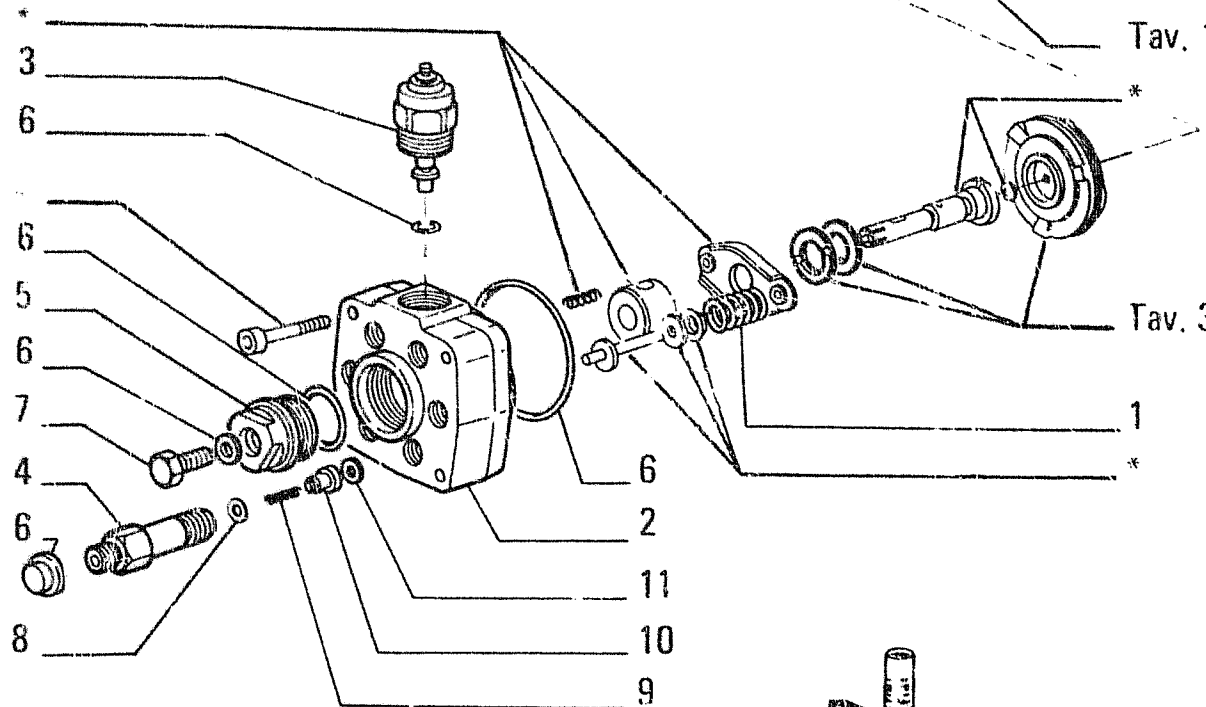
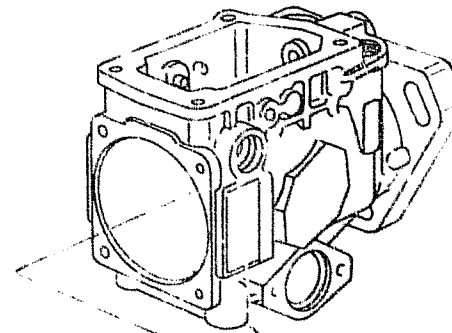

I T E M	PART NUMBER	Q T Y	TRANS CODE	DESCRIPTION	DESCRIZIONE
1	79074030	1	100M	SPRING	MOLLA
2	79082100	1	35S	CASE	SCATOLA
3	79082108	1	12M	MAGNETO	MAGNETE
4	79082097	1	16A	SHAFT	ALBERO
5	79071396	1	50T	PLUG	TAPPO
6	79071400	1	2K	KIT	KIT
7	79071398	1	40V	SCREW	VITE
8	9918625	6	131R	WASHER	ROSETTA
9	79082098	6	80P	PIN	PERNO
10	79082099	6	10V	VALVE	VALVOLA
11	79071392	6	131R	WASHER	ROSETTA

D 1572 Tel. n. 250905 →

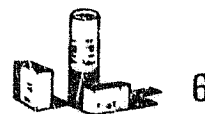

4807436

INJECTION PUMP - POMPA INIEZIONE - POMPE D'INJECTION - EINSPRITZPUMPE - BOMBA DE INYECCION

A2.27/A

4

N.T.R. 200 - 15.10.1990

604.01.081.05

N3

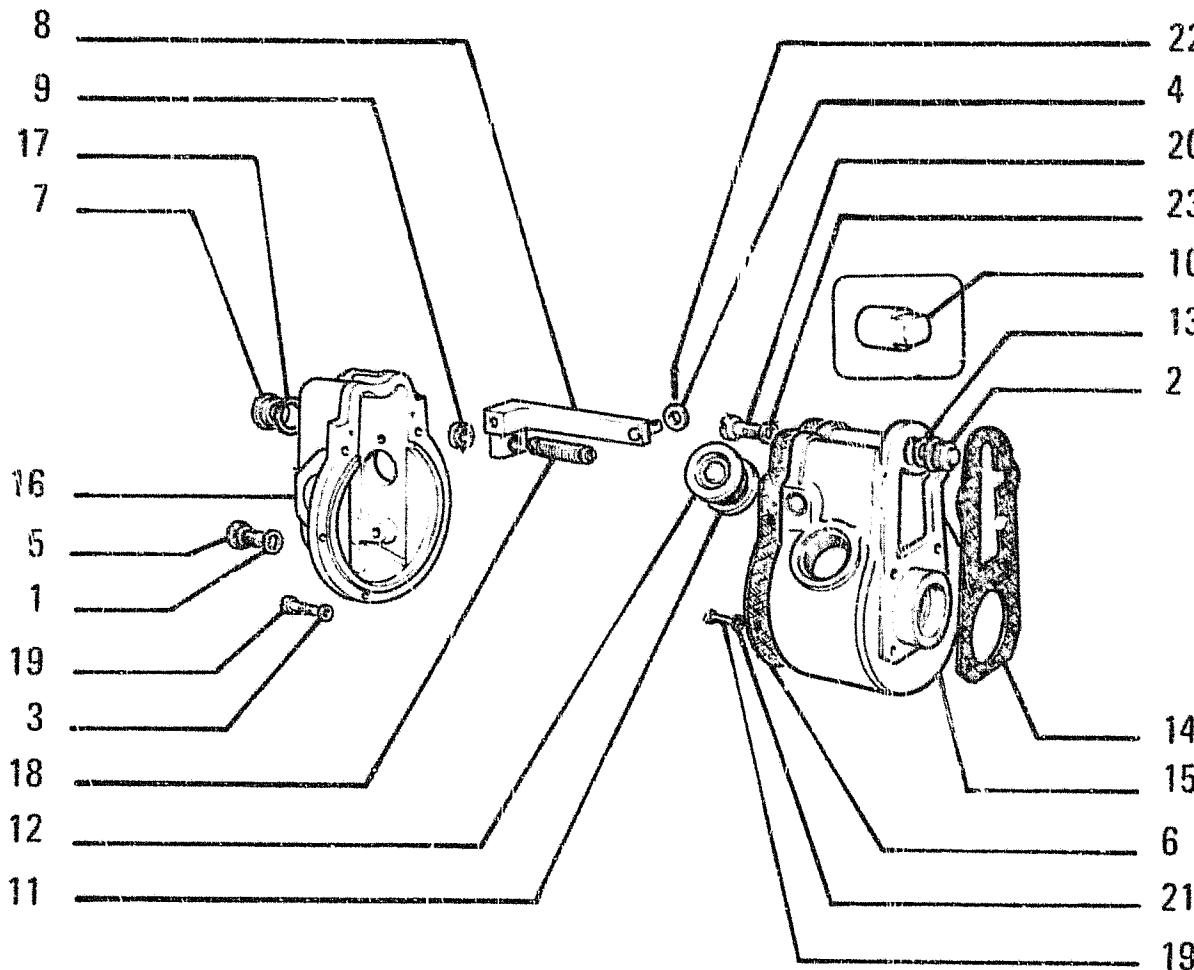

C 1572 → Tel.n. 250904

ITEM	PART NUMBER	QTY	TRANS CODE	DESCRIPTION	DESCRIZIONE
1	726381	1	133R	SEAL	ROSETTA DI TENUTA
2	747210	1	40V	SCREW	VITE
3	753177	6	123G	SEAL ASSY	GUARNIZIONE TENUTA FRONTALE
4	753195	5	131R	WASHER	ROSETTA
5	757354	1	50T	PLUG	TAPPO
6	760203	1	123G	SEAL ASSY	GUARNIZIONE TENUTA FRONTALE
7	760666	1	50T	PLUG	TAPPO
8	763440	1	142T	TIEROD	TIRANTE
9	765342	1	50G	RING NUT	GHIERA
10	766075	1	65C	BGOT	CAPPUCCIO
11	767314	1	123G	SEAL ASSY	GUARNIZIONE TENUTA FRONTALE
12	767315	1	50T	PLUG	TAPPO
13	768043	1	133R	SEAL	ROSETTA DI TENUTA
14	769357	1	123G	SEAL ASSY	GUARNIZIONE TENUTA FRONTALE
15	771702	1	35S	CASE	SCATOLA
16	769378	1	265C	COVER	COPERCHIO
17	769542	1	123G	SEAL ASSY	GUARNIZIONE TENUTA FRONTALE
18	771647	1	80A	STOP	ARRESTO
19	10376711	10	40V	SCREW 6x1x16	VITE 6x1x16
20	10378811	1	40V	SCREW 8x1,25x16	VITE 8x1,25x16
21	10516470	4	132R	LOCKWASHER 6,1x1,8	ROSETTA DI SICUREZZA 6,1x1,8
22	10734401	1	270C	COTTER PIN 1,7x28,5	COPIGLIA 1,7x28,5
23	722023	1	133R	SEAL	ROSETTA DI TENUTA

771646

SPEED GOVERNOR - REGOLATORE DI VELOCITA' - REGULATEUR DE VITESSE - DREHZAHLEGLER
 REGULADOR DE VELOCIDAD

A2.28

1

N.T.R. 191 - 20.02.1990

604.01.081.04

N4

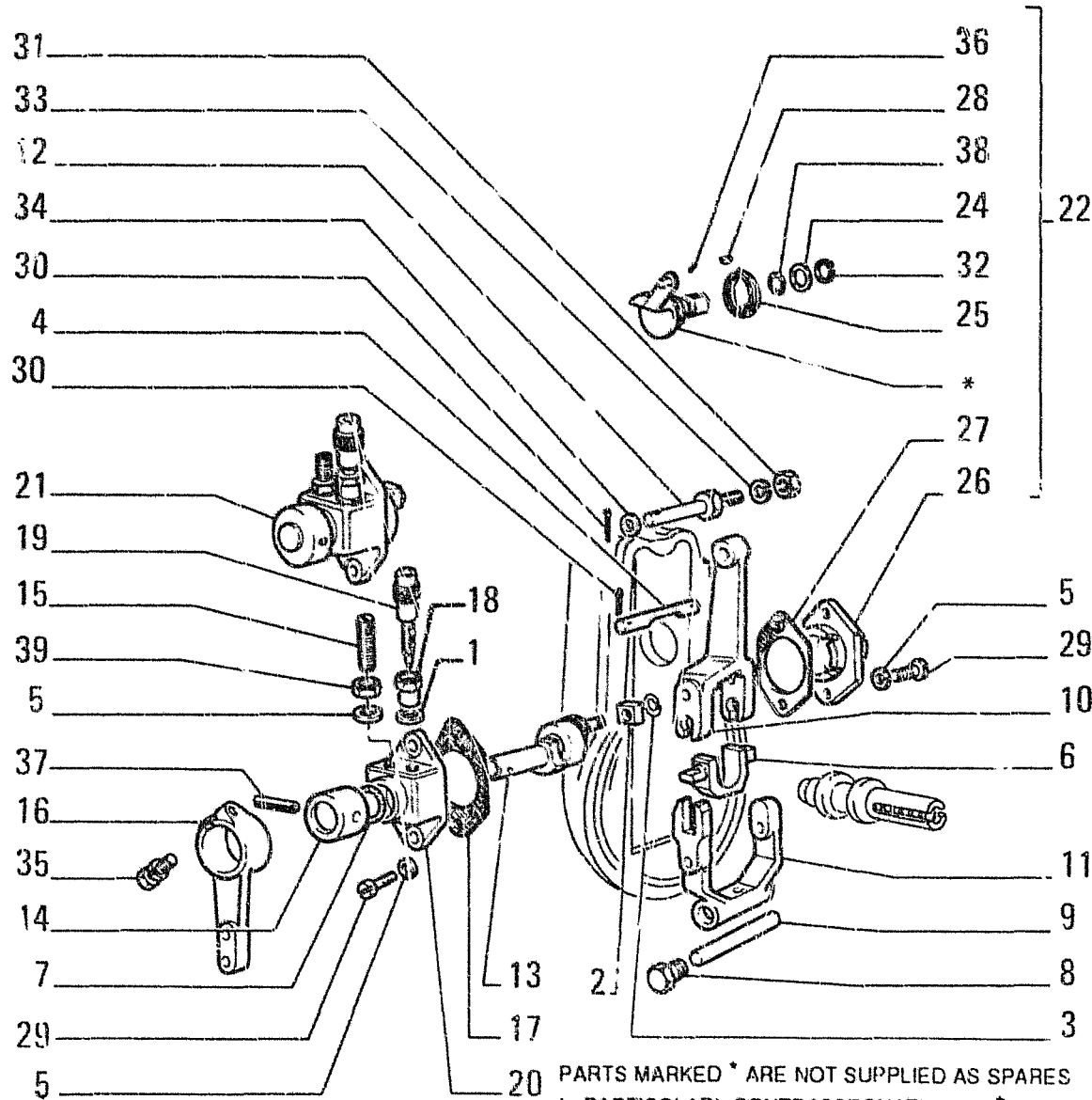

C 1572 → Tel.n. 250904

PARTS MARKED * ARE NOT SUPPLIED AS SPARES
I PARTICOLARI CONTRASSEGNA TI CON * NON
VENGONO FORNITI DI RICAMBIO

ITEM	PART NUMBER	QTY	TRANS CODE	DESCRIPTION	DESCRIZIONE
1	722023	1	133R	SEAL	ROSETTA DI TENUTA
2	722282	1	45P	PAD	PATTINO
3	722283	1	51A	LOCKRING	ANELLO DI SICUREZZA
4	723838	1	80P	PIN	PERNO
5	753177	5	123G	SEAL ASSY	GUARNIZIONE TENUTA FRONTALE
6	759016	1	165S	ARTICULATION	SNODO
7	759146	1	158G	O-RING	GUARNIZIONE O-R
8	760925	2	50T	PLUG	TAPPO
9	760926	1	80P	PIN	PERNO
10	763235	1	45L	LEVER	LEVA
11	763236	1	85F	YOKE	FORCELLA
12	763432	1	80P	PIN	PERNO
13	765503	1	17A	CAMSHAFT	ALBERO AD ECCENTRICI
14	765504	1	95B	BUSHING	BOCCOLA
15	765505	1	90G	DOWEL	GRANO
16	765632	1	45L	LEVER	LEVA
17	766432	1	123G	SEAL ASSY	GUARNIZIONE TENUTA FRONTALE
18	767977	1	10D	NUT	DADO
19	767980	1	238P	PUSH ROD	PUNTALE
20	767981	1	300S	SUPPORT	SUPPORTO
21	767982	1	189C	CONTROL - ASSEMBLY	COMANDO - COMPLETO
22	771463	1	80A	STOP - ASSEMBLY	ARRESTO - COMPLETO
24	771468	1	131R	WASHER	ROSETTA
25	771469	1	100M	SPRING	MOLLA
26	771470	1	300S	SUPPORT	SUPPORTO
27	771471	1	123G	SEAL ASSY	GUARNIZIONE TENUTA FRONTALE
28	10205610	1	60L	KEY 3,7x2,5	LINGUETTA 3,7x2,5

771646

SPEED GOVERNOR - REGOLATORE DI VELOCITA' - REGULATEUR DE VITESSE - DREHZAHLEGLER -
REGULADOR DE VELOCIDAD

N5

A2.28

2

N.T.R. 205 - 30.09.1991
604.01.081.06

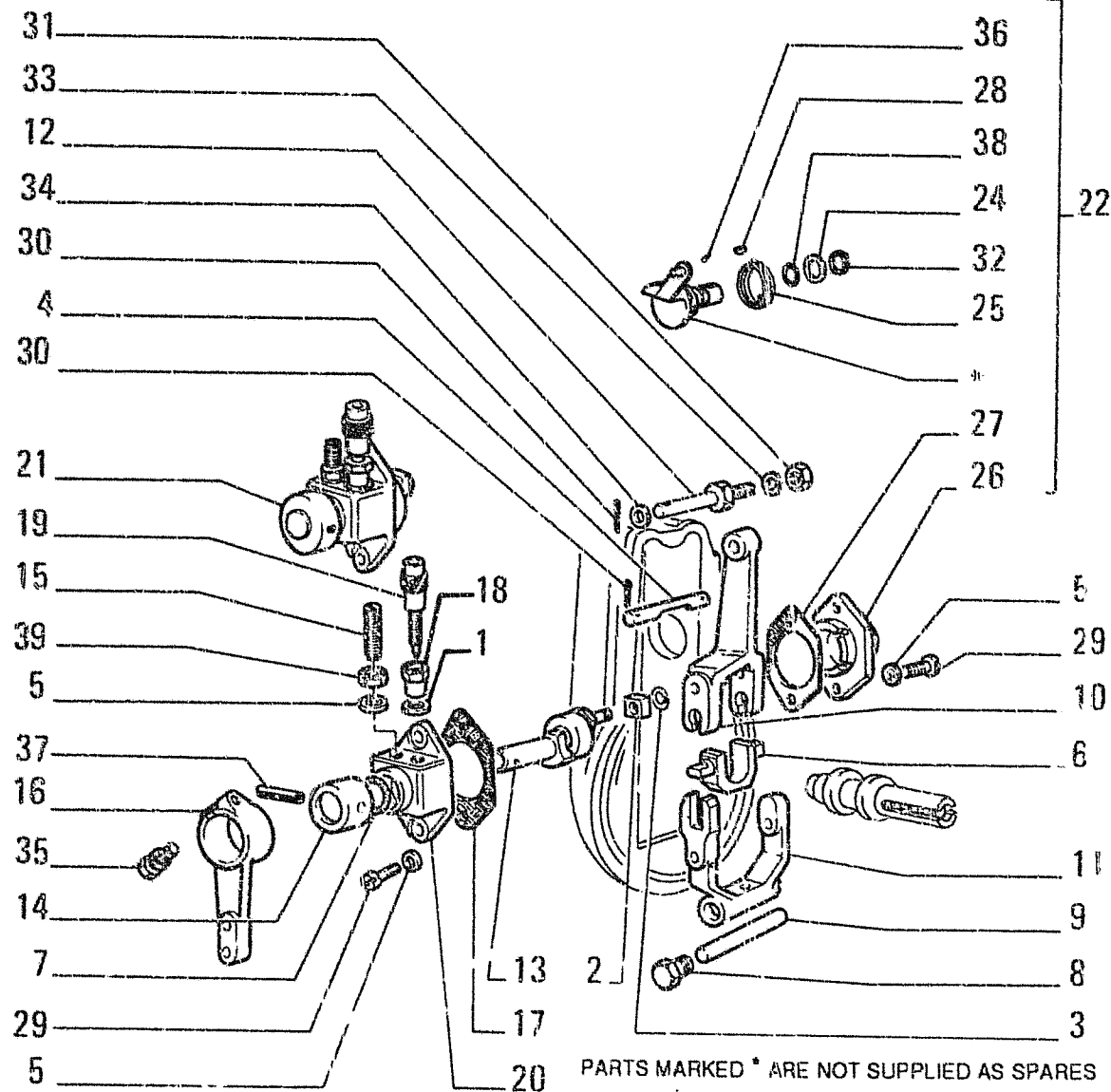

PARTS MARKED * ARE NOT SUPPLIED AS SPARES
 I PARTICOLARI CONTRASSEGNAI CON * NON VENGONO FORNITI DI RICAMBIO

ITEM	PART NUMBER	QTY	TRANS CODE	DESCRIPTION	DESCRIZIONE
29	10376611	4	40V	SCREW 6x1x14	VITE 6x1x14
30	10734101	2	270C	COTTER PIN 1,3x17,7	COPIGLIA 1,3x17,7
31	10788811	1	10D	NUT 5x0,8x3,5	DAJJO 5x0,8x3,5
32	11065876	1	51A	LOCKRING 10,2x1,8	NELLO DI SICUREZZA 10,2x1,8
33	11195470	1	132R	LOCKWASHER 5,1x1,1	ROSETTA DI SICUREZZA 5,1x1,1
34	12633701	1	131R	WASHER 6,15x11	FOSETTA 6,15x11
35	13824611	1	40V	SCREW 6x1x25	VITE 6x1x25
36	14163370	1	200S	PIN 4,4x8	SPINA 4,4x8
37	14164170	1	200S	PIN 4,4x25	SPINA 4,4x25
38	14452830	1	158G	O-RING 1,78x7,65	GUARNIZIONE O-R 1,78x7,65
39	15896211	1	10D	NUT 6x1x5	DAJJO 6x1x5

C 1572 → Tel.n. 250904

771646

SPEED GOVERNOR – REGOLATORE DI VELOCITA' – REGULATEUR DE VITESSE – DREHZAHLEGLER –
 REGULADOR DE VELOCIDAD

A2.28	2
N.T.R. 205 - 30.09.1991	
604.01.081.06	

N6

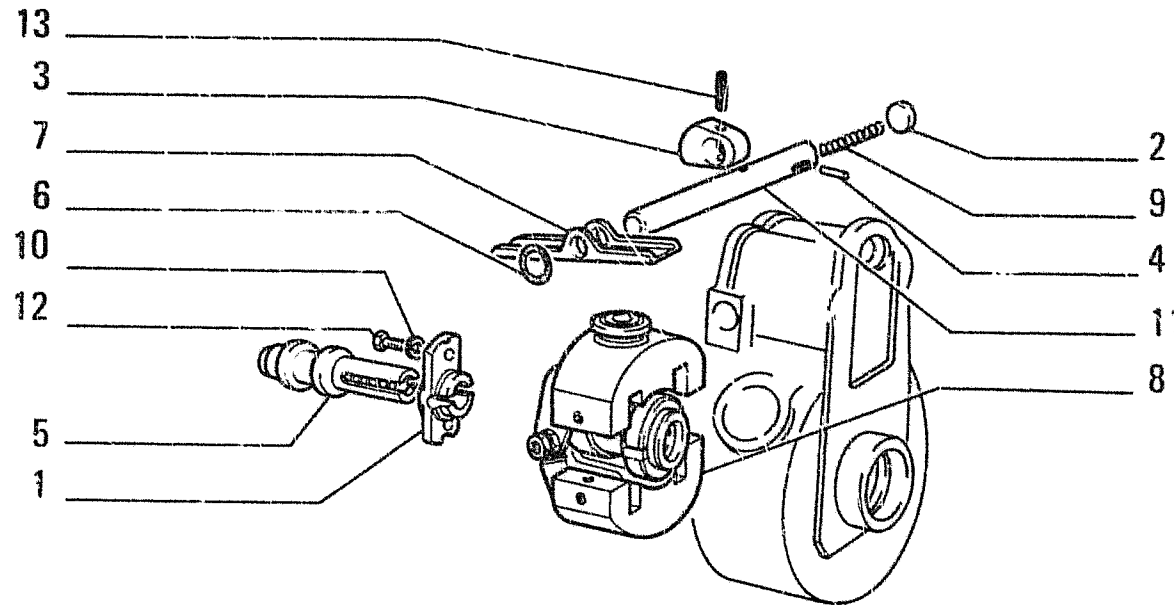

ITEM	PART NUMBER	QTY	TRANS CODE	DESCRIPTION	DESCRIZIONE
1	706197	1	95B	BUSHING	BOCCOLA
2	757357	1	50T	PLUG	TAPPO
3	759011	1	80A	STOP	ARRESTO
4	759046	1	80P	PIN	PERNO
5	763187	1	80P	PIN	PERNO
6	764582	1	158G	O-RING	GUARNIZIONE O-R
7	765256	1	266C	SHROUD	CONVOGLIATORE
8	766662	1	72D	GOVERNOR REGULATING ASSY - ASSEMBLY SEE SGR. A2.37	DISPOSITIVO DI REGOLAZIONE - COMPLETO VEDERE SGR. A2.37
9	768161	1	100M	SPRING	MOLLA
10	768757	2	113P	LOCKPLATE	PIASTRINA DI SICUREZZA
11	768950	1	16A	SHAFT	ALBERO
12	10902311	2	40V	SCREW 6x1x18	VITE 6x1x18
13	14161970	1	200S	PIN 3,3x20	SPINA 3,3x20

C 1572 → Tel.n. 250904

771646
 SPEED GOVERNOR – REGOLATORE DI VELOCITA' – REGULATEUR DE VITESSE – DREHZAHLEGLER –
 REGULADOR DE VELOCIDAD

A2.28

3

N.T.R. 158 - 13.03.1987

604.01.081.03

N7

FIATALLIS FDT

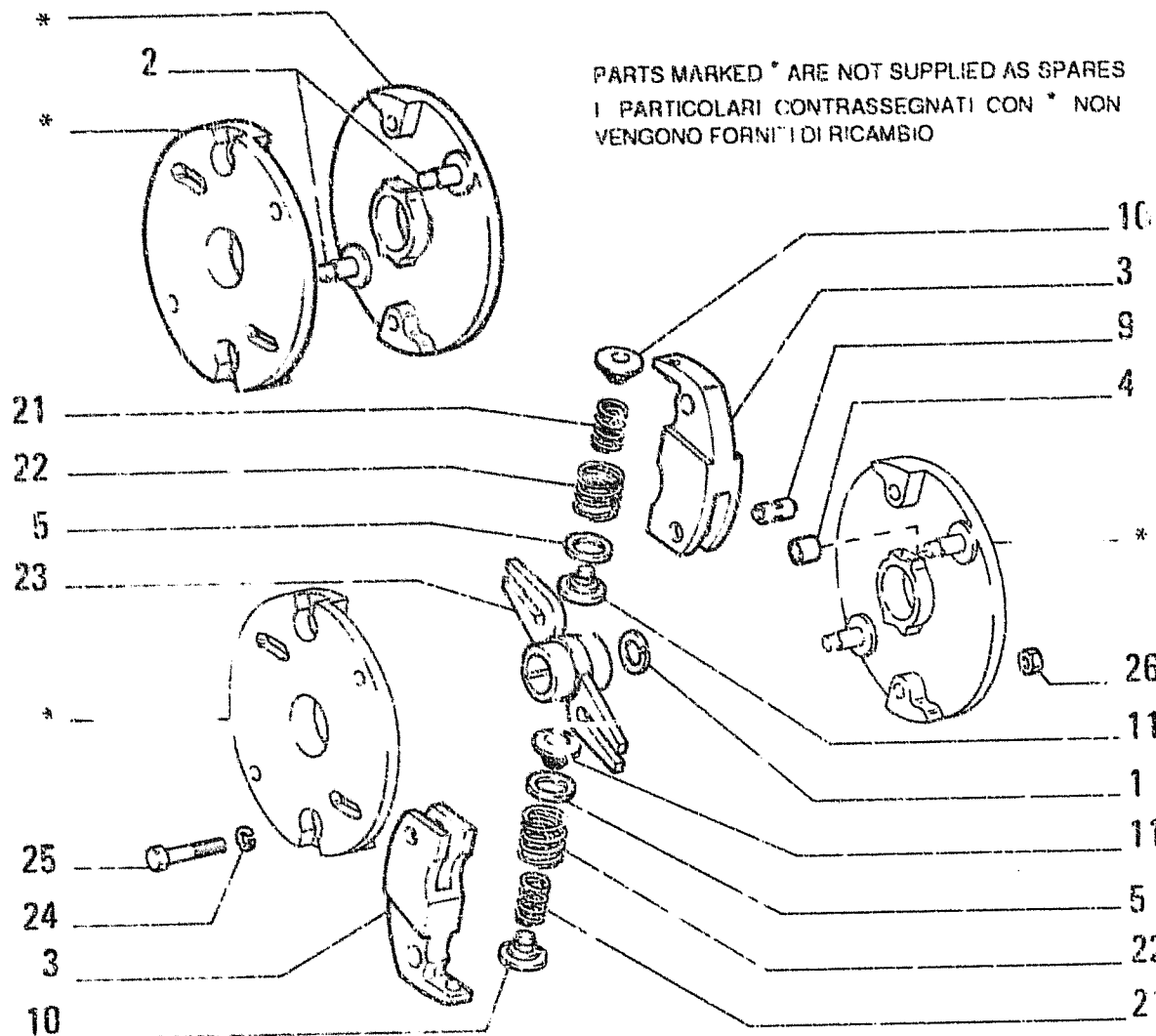

C 1572 → Tel.n. 250904

ITEM	PART NUMBER	QTY	TRANS CODE	DESCRIPTION	DESCRIZIONE
1	773102	1	51A	LOCKRING	ANELLO DI SICUREZZA
2	773118	2		20P PIN	PERNO
3	773120	2	65M	FLYWEIGHT	MASSA ANTICIPO
4	773129	2		95B BUSHING	BOCCOLA
5	773131			131R WASHER - THICKNESS 0.3	ROSETTA - SPESSORE 0.3
	773132			131H WASHER - THICKNESS 0.10	ROSETTA - SPESSORE 0.10
	773133			131R WASHER - THICKNESS 0.15	ROSETTA - SPESSORE 0.15
9	773139	2		45P PAD	PATTINO
10	773140	2		120P PLATE - LOWER	PIATTELLO - INFERIORE
11	773143			120P PLATE - UPPER THICKNESS 14,4	PIATTELLO - SUPERIORE SPESSORE 14,4
	773144			120P PLATE - UPPER THICKNESS 14,5	PIATTELLO - SUPERIORE SPESSORE 14,5
	773145			120P PLATE - UPPER THICKNESS 14,6	PIATTELLO - SUPERIORE SPESSORE 14,6
	773146			120P PLATE - UPPER THICKNESS 14,7	PIATTELLO - SUPERIORE SPESSORE 14,7
	773147			120P PLATE - UPPER THICKNESS 14,8	PIATTELLO - SUPERIORE SPESSORE 14,8
	773148			120P PLATE - UPPER THICKNESS 14,9	PIATTELLO - SUPERIORE SPESSORE 14,9
	773149			120P PLATE - UPPER THICKNESS 15,0	PIATTELLO - SUPERIORE SPESSORE 15,0
	773150			120P PLATE - UPPER THICKNESS 15,1	PIATTELLO - SUPERIORE SPESSORE 15,1
	773151			120P PLATE - UPPER THICKNESS 15,2	PIATTELLO - SUPERIORE SPESSORE 15,2

4758943

ADVANCE DEVICE - VARIATORE DI ANTICIPO - CORRECTEUR D'AVANCE - SPRITZZEITVERSTELLER - VARIADOR DE AVANCE

A2.33

N.T.R. 205 30.09.1991
604.01.081.06

N8

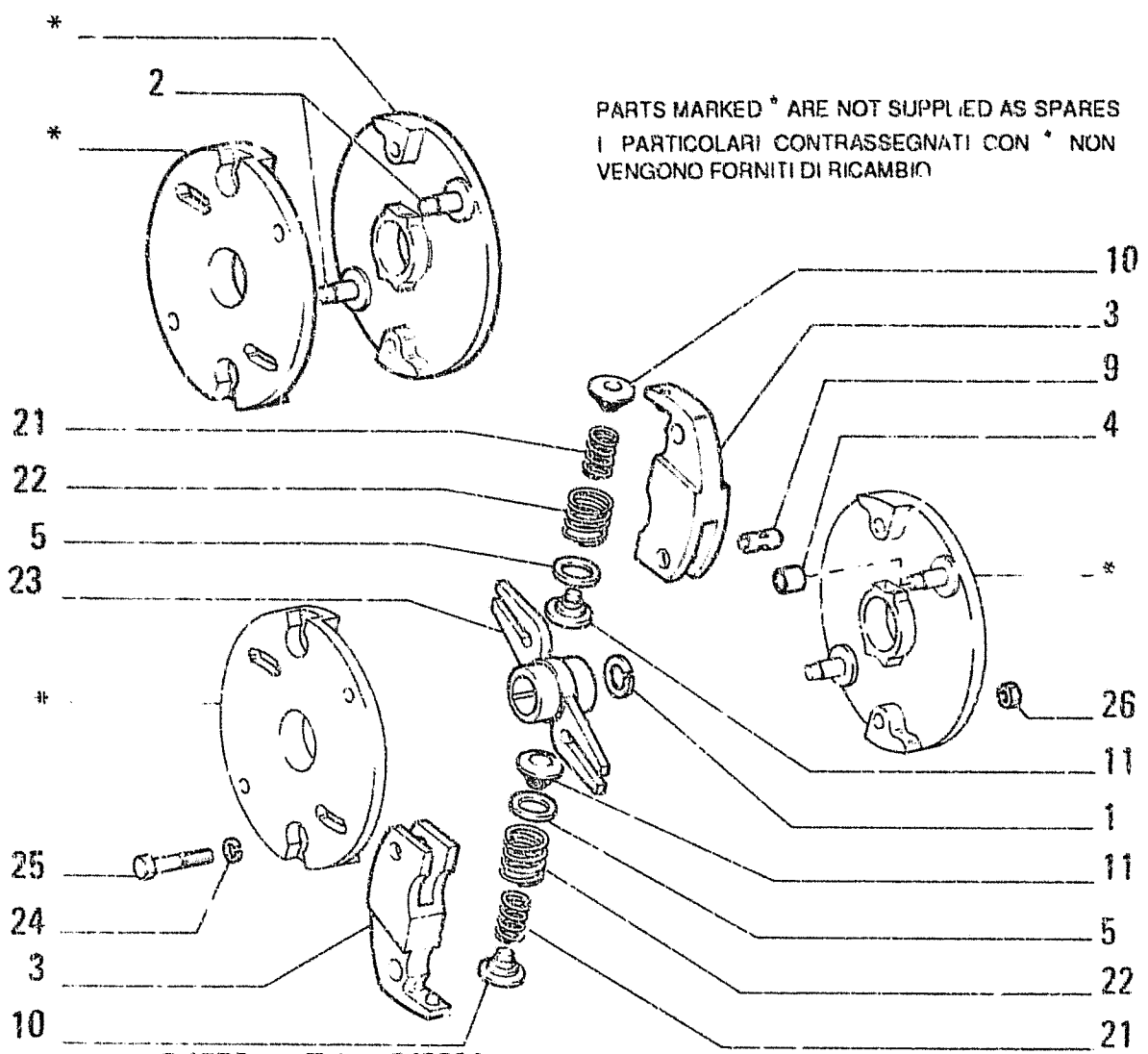

ITEM	PART NUMBER	QTY	TRANS CODE	DESCRIPTION	DESCRIZIONE
11	773152			120P PLATE - UPPER THICKNESS 15,3	PIATTELLO - SUPERIORE SPESSORE 15,3
21	773242	2		100M SPRING	MOLLA
22	773280	2		100M SPRING	MOLLA
23	773281	1		75G LINK	GLIFO
24	11194071	2		132R LOCKWASHER 8,4x16	ROSETTA DI SICUREZZA 8,4x16
25	16044030	2		40V SCREW 6x1,25x40	VITE 8x1,25x40
26	16100811	2		10D NUT 8x1,25x6,5	DADO 8x1,25x6,5

C 1572 → Tel.n. 250904

4758943

ADVANCE DEVICE - VARIATORE DI ANTIPO - CORRECTEUR D'AVANCE - SPRITZZEITVERSTELLER - VARIADOR DE AVANCE

A2.33

N.T.R. 205 - 30.09.1991
604.01.081.06

N9

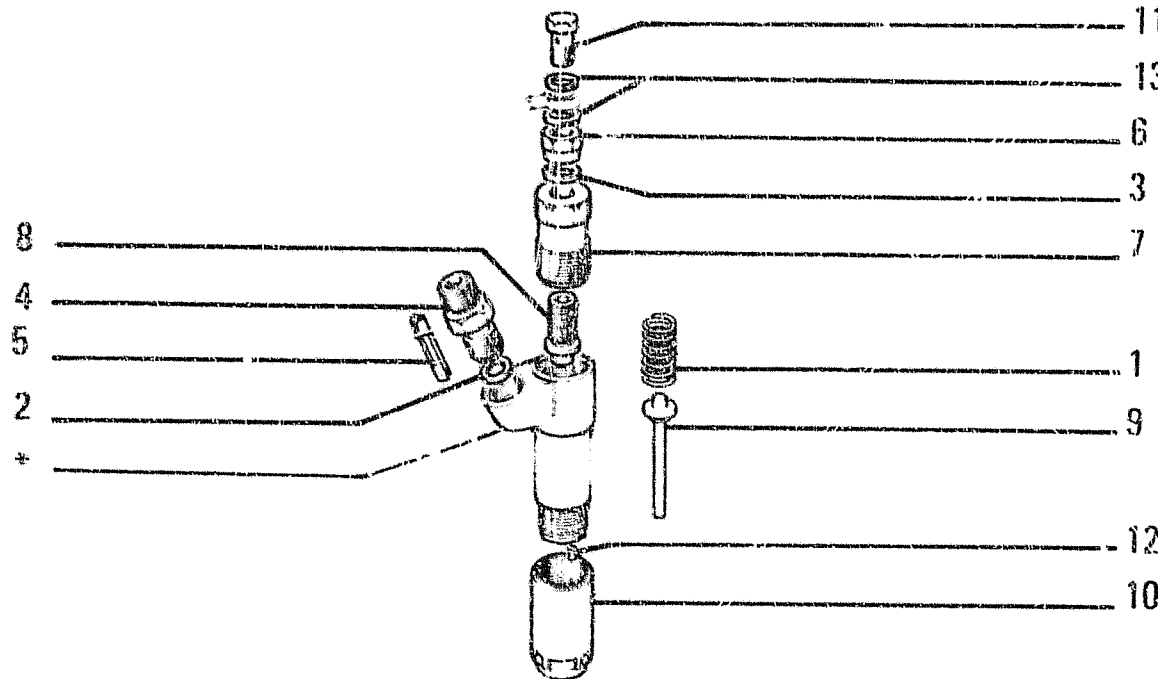

ITEM	PART NUMBER	QTY	TRANS CODE	DESCRIPTION	DESCRIZIONE
1	656829	1	100M	SPRING	MOLLA
2	722027	1	133R	SEAL	ROSETTA DI TENUTA
3	726381	1	133R	SEAL	ROSETTA DI TENUTA
4	765103	1	20R	FITTING	RACCORDO
5	766193	1	65F	FILTER	FILTRC
6	766837	1	10D	NUT	DADO
7	766838	1	50T	PLUG	TAPPO
8	766839	1	40V	SCREW	VITE
9	767110	1	90A	ROD	ASTA
10	767112	1	10D	NUT	DADO
11	767451	1	20R	FITTING	RACCORDO
12	768378	2	90G	DOWEL	GRANO
13	79038242	2	133R	SEAL	ROSETTA DI TENUTA.

PARTS MARKED * ARE NOT SUPPLIED AS SPARES
 I PARTICOLARI CONTRASSEGNAI CON * NON
 VENGONO FORNITI DI RICAMBIO

C 1572 → Tel.n. 250904

767107
 NOZZLE HOLDER -- PORTAPOLVERIZZATORE -- PORTE-INJECTEUR -- DUESENHALTER --
 PORTAINYECTOR

A2.35

N.T.R. 200 - 15.10.1990

604.01.081.C5

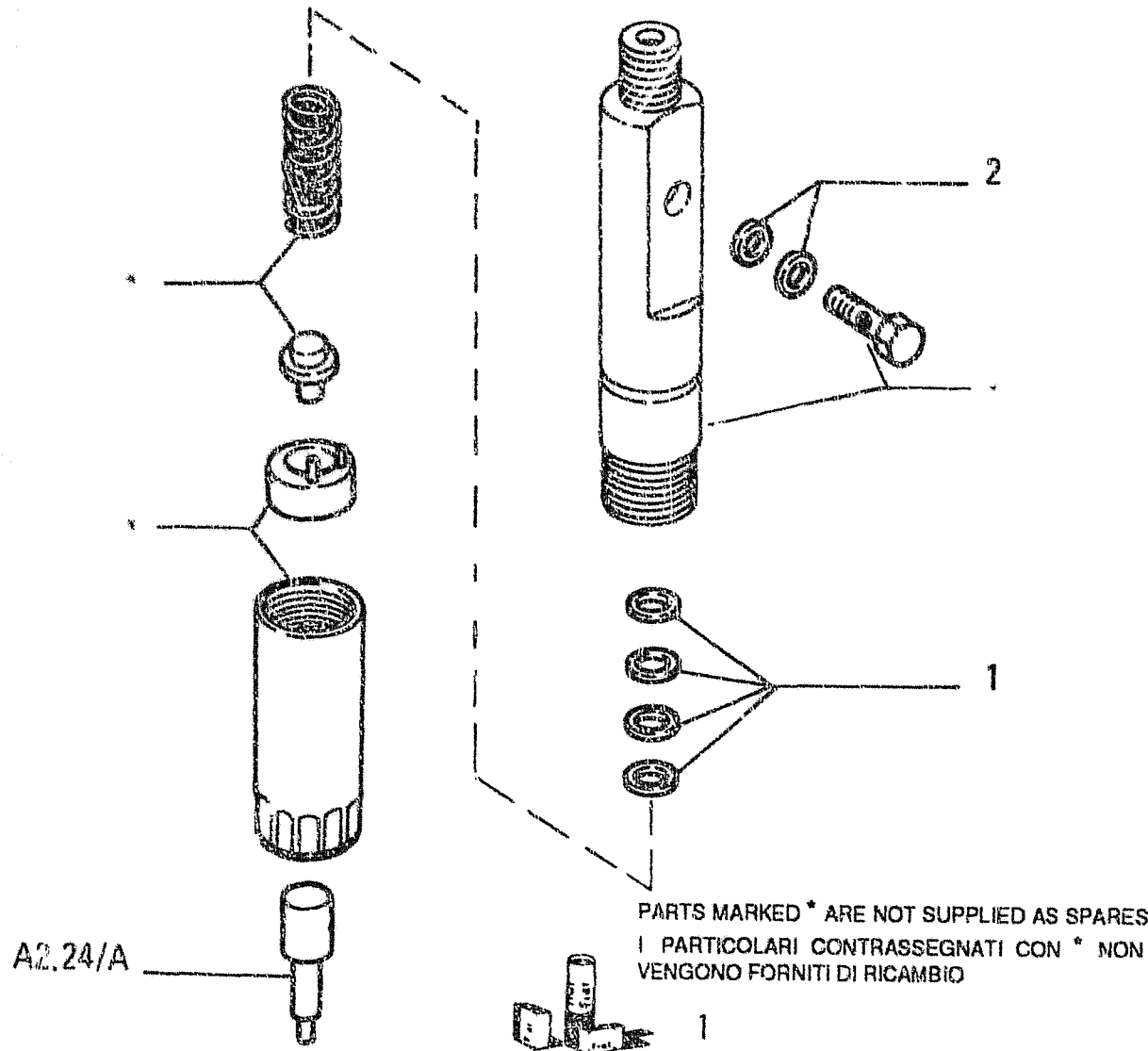

ITEM	PART NUMBER	QTY	TRANS CODE	DESCRIPTION	DESCRIZIONE
1	772799		198S	SHIM 1,825MM D3280	SPESSORE 1,825MM D3280
	772800		198S	SHIM 1,850MM D3280	SPESSORE 1,850MM D3280
	772801		198S	SHIM 1,875 MM D3280	SPESSORE 1,875 MM D3280
	772802		198S	SHIM 1,900 MM D3280	SPESSORE 1,900 MM D3280
	772803		198S	SHIM 1,925MM D3280	SPESSORE 1,925MM D3280
	772804		198S	SHIM 1,950MM D3280	SPESSORE 1,950MM D3280
	772805		198S	SHIM 1,975 MM D3280	SPESSORE 1,975 MM D3280
	775013	1	2K	KIT C2935	KIT C2935
	775014		198S	SHIM 0,30MM D2935	SPESSORE 0,30MM D2935
	775015		198S	SHIM 0,41MM D2935	SPESSORE 0,41MM D2935
	775016		198S	SHIM 0,44MM D2935	SPESSORE 0,44MM D2935
	775017		198S	SHIM 0,47MM D2935	SPESSORE 0,47MM D2935
	775018		198S	SHIM 0,50MM D2935	SPESSORE 0,50MM D2935
	775019		198S	SHIM 0,53MM D2935	SPESSORE 0,53MM D2935
	775025		198S	SHIM 0,56MM D2935	SPESSORE 0,56MM D2935
	775026		198S	SHIM 0,59MM D2935	SPESSORE 0,59MM D2935
	775027		198S	SHIM 0,62MM D2935	SPESSORE 0,62MM D2935
	775028		198S	SHIM 0,65MM D2935	SPESSORE 0,65MM D2935
	775029		198S	SHIM 0,68MM D2935	SPESSORE 0,68MM D2935
	775030		198S	SHIM 0,98MM D2935	SPESSORE 0,98MM D2935
	775031		198S	SHIM 1,28MM D2935	SPESSORE 1,28MM D2935
	775032		198S	SHIM 1,58MM D2935	SPESSORE 1,58MM D2935
	775113	1	1K	KIT SEE PAGE 9 D3280	KIT VED. PAG.9 D3280
	775116		198S	SHIM 1,80MM D2935	SPESSORE 1,80MM D2935
			198S	SHIM 1,80 MM C3280	SPESSORE 1,80 MM C3280
	775146		198S	SHIM 2,18MM D2935	SPESSORE 2,18MM D2935
			198S	SHIM 2,18MM C3280	SPESSORE 2,18MM C3280

D 1572 Tel. n. 250905 →

4802392 (WEBER)

NOZZLE HOLDER - PORTAPOLVERIZZATORE - PORTE-INJECTEUR - DUESENHALTER - PORTAINYECTOR

A2.35/A

N.T.R. 200 - 15.10.1990

604.01.081.05

N11

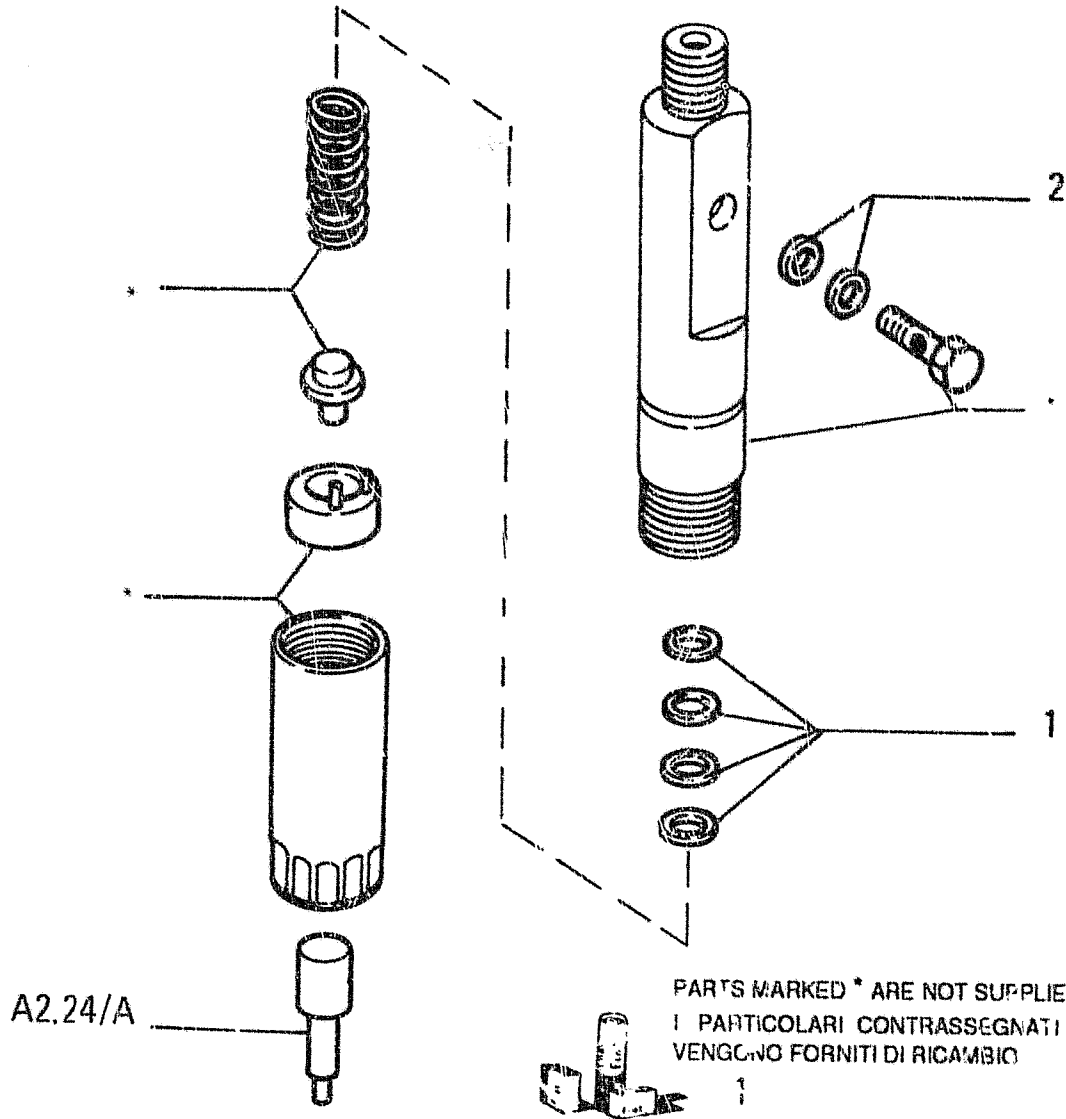

A2.24/A

D 1572 Tel. n. 250905 →

ITEM	PART NUMBER	QTY	TRANS CODE	DESCRIPTION	DESCRIZIONE
1	775589		198S SHIM 2,000 MM	D3280	SPESSORE 2,000 MM D3280
	775590		198S SHIM 2,025 MM	D3280	SPESSORE 2,025 MM D3280
	775591		198S SHIM 2,050 MM	D3280	SPESSORE 2,050 MM D3280
	775592		198S SHIM 2,075 MM	D3280	SPESSORE 2,075 MM D3280
	775593		198S SHIM 2,100 MM	D3280	SPESSORE 2,100 MM D3280
	775594		198S SHIM 2,125 MM	D3280	SPESSORE 2,125 MM D3280
	775595		198S SHIM 2,150 MM	D3280	SPESSORE 2,150 MM D3280
	775596		198S SHIM 2,175 MM	D3280	SPESSORE 2,175 MM D3280
	775597		198S SHIM 2,200 MM	D3280	SPESSORE 2,200 MM D3280
	775598		198S SHIM 2,225 MM	D3280	SPESSORE 2,225 MM D3280
	775599		198S SHIM 2,250 MM	D3280	SPESSORE 2,250 MM D3280
	775600		198S SHIM 2,275 MM	D3280	SPESSORE 2,275 MM D3280
	775601		198S SHIM 2,300 MM	D3280	SPESSORE 2,300 MM D3280
2	772051	2	131R WASHER		ROSETTA

PARTS MARKED * ARE NOT SUPPLIED AS SPARES
 I PARTICOLARI CONTRASSEGNA TI CON * NON VENGONO FORNITI DI RICAMBIO

4802392 (WEBER)
 NOZZLE HOLDER - PORTAPOLVERIZZATORE - PORTE-INJECTEUR - DUESENHALTER - PORTAINJECTOR

A2.35/A

N.T.R. 200 - 15.10.1990
 604.01.081.05

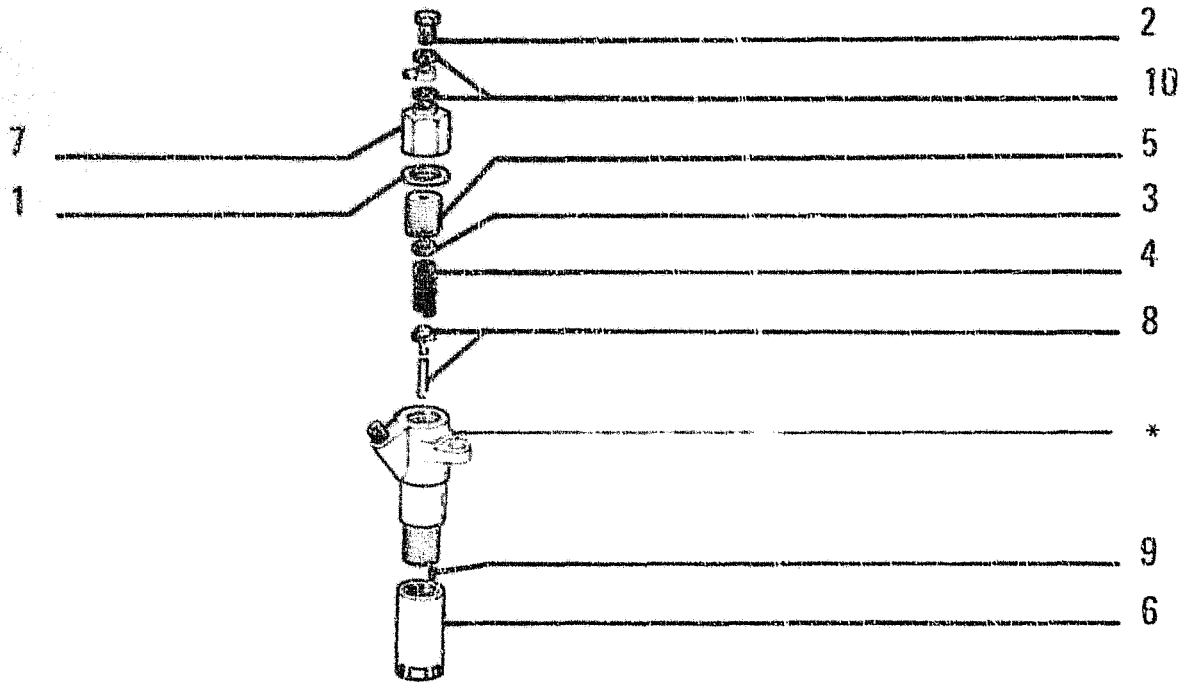

ITEM	PART NUMBER	QTY	TRANS CODE	DESCRIPTION	DESCRIZIONE
1	9928366	1	133R	SEAL	ROSETTA DI TENUTA
	9928367	1	90B	FILLER PLUG	BOCCI ETTONE INTRODUZIONE
3	9928369	1	75D	SPACER	DISTANZIALE
4	9928370	1	100M	SPRING	MOLLA
5	9928371	1	40V	SCREW	VITE
6	9928373	1	51G	THREADED RING	GHIERA FILETTATA
7	9928374	1	51G	THREADED RING	GHIERA FILETTATA
8	9928375	1	90A	ROD	ASTA
9	9928376	2	90G	DOWEL	CRANO
10	9928396	2	133R	SEAL	ROSETTA DI TENUTA

PARTS MARKED * ARE NOT SUPPLIED AS SPARES
 I PARTICOLARI CONTRASSEGNA TI CON * NON
 VENGONO FORNITI DI RICAMBIO

C 1572 → Tel.n. 250904

770899 (C.A.V.)
 NOZZLE HOLDER — PORTAPOLVERIZZATORE — PORTE-INJECTEUR — DUESENHALTER —
 PORTAINJECTOR

A2.35/1
 N.T.R. 200 - 15.10.1990
 604.01.081.05

N13

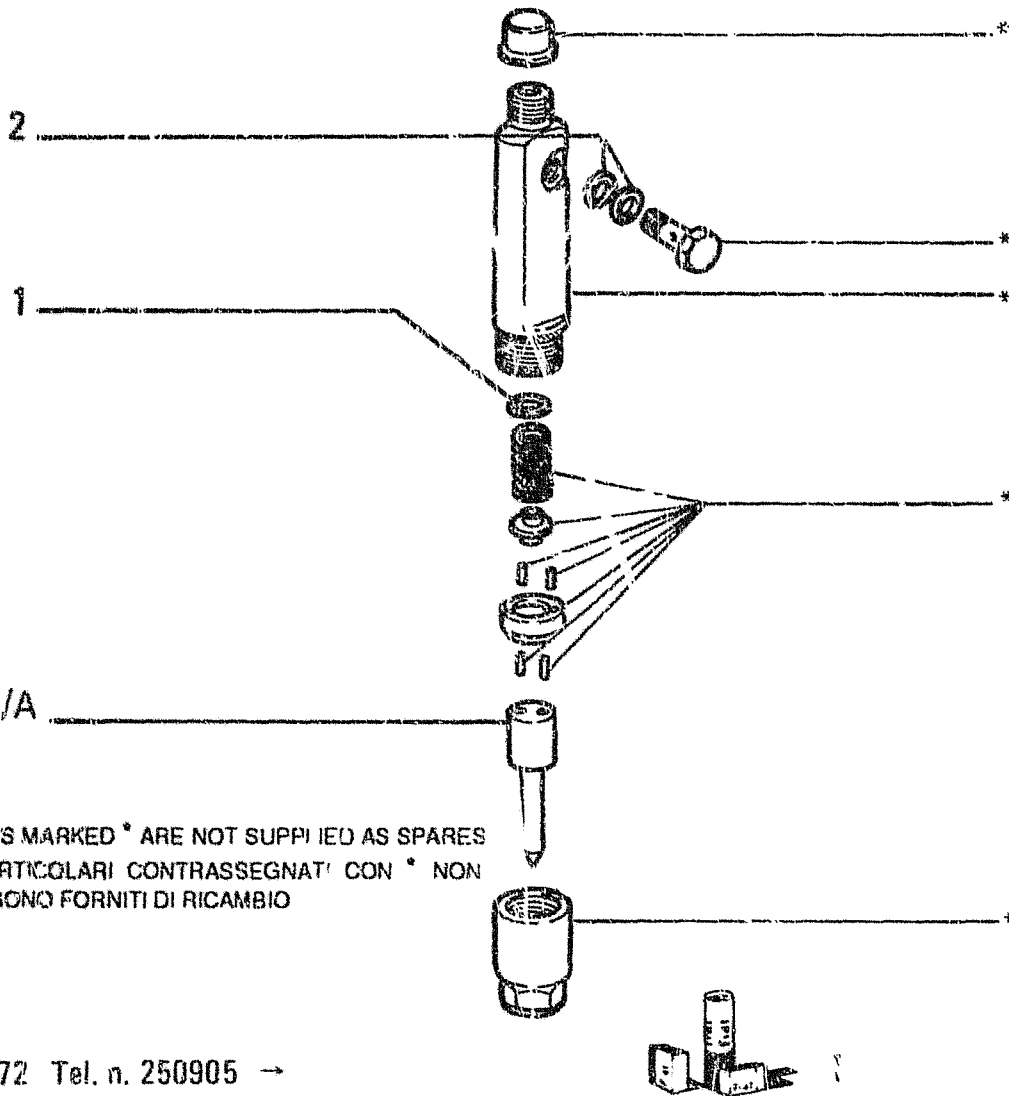

ITEM	PART NUMBER	QTY	TRANS CODE	DESCRIPTION	DESCRIZIONE
1	79067856	1	2K KIT		KIT
2	772051	2	131R WASHER		ROSETT.

A2.24/A

PARTS MARKED * ARE NOT SUPPLIED AS SPARES
 I PARTICOLARI CONTRASSEGNAI CON * NON
 VENGONO FORNITI DI RICAMBIO

D 1572 Tel. n. 250905 →

4791124 (Bosch)

NOZZLE HOLDER - PORTAPOLVERIZZATORE - PORTE-INJECTEUR - DUESENHALTER - PORTA-
 INYECTOR

A2.35/1A

N.T.N. 200 15.10.1990

604.01.081.05

N14

VCA

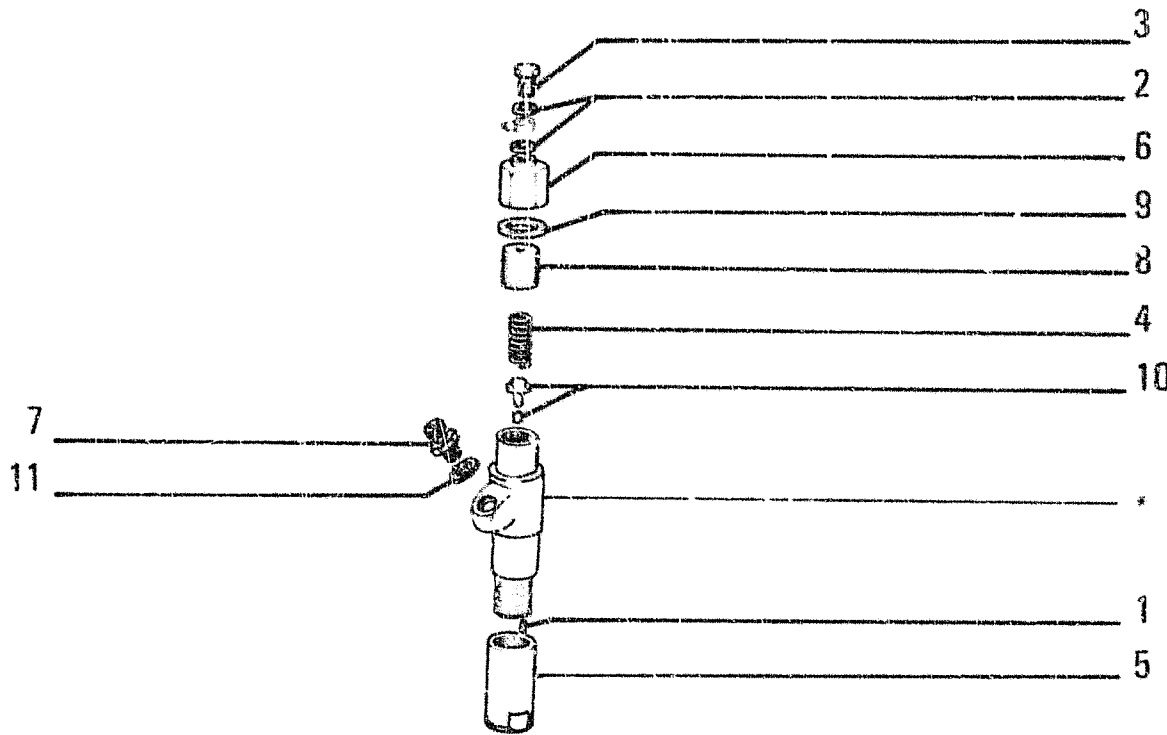

ITEM	PART NUMBER	QTY	TRANS CODE	DESCRIPTION	DESCRIZIONE
1	9931247	2	200S PIN		SPINA
2	9928391	2	1.13R SEAL		ROSETTA DI TENUTA
3	9928392	1	20R FITTING		RACCORDO
4	9930019	1	100M SPRING		MOLLA
5	9930021	1	51G THREADED RING		GHIERA FILETTATA
6	9930022	1	51G THREADED RING		GHIERA FILETTATA
7	9930023	1	20R FITTING		RACCORDO
8	9930024	1	40V SCREW		VITE
9	9930025		158G O-RING		GUARNIZIONE O-R
10	9930026	1	90A ROD		ASTA
11	9930027	1	158G O-RING		GUARNIZIONE O-R

PARTS MARKED * ARE NOT SUPPLIED AS SPARES
 I PARTICOLARI CONTRASSEGNA TI CON * NON
 VENGONO FORNITI DI RICAMBIO

C 1572 → Tel.n. 250904

770958 (OMAP)

NOZZLE HOLDER -- PORTAPOLVERIZZATORE -- PORTE - INJECTEUR -- DUESENHALTER --
 PORTAINJECTOR

A2.35/2

N.T.R. 200 - 15.10.1990

604.01.081.05

N15

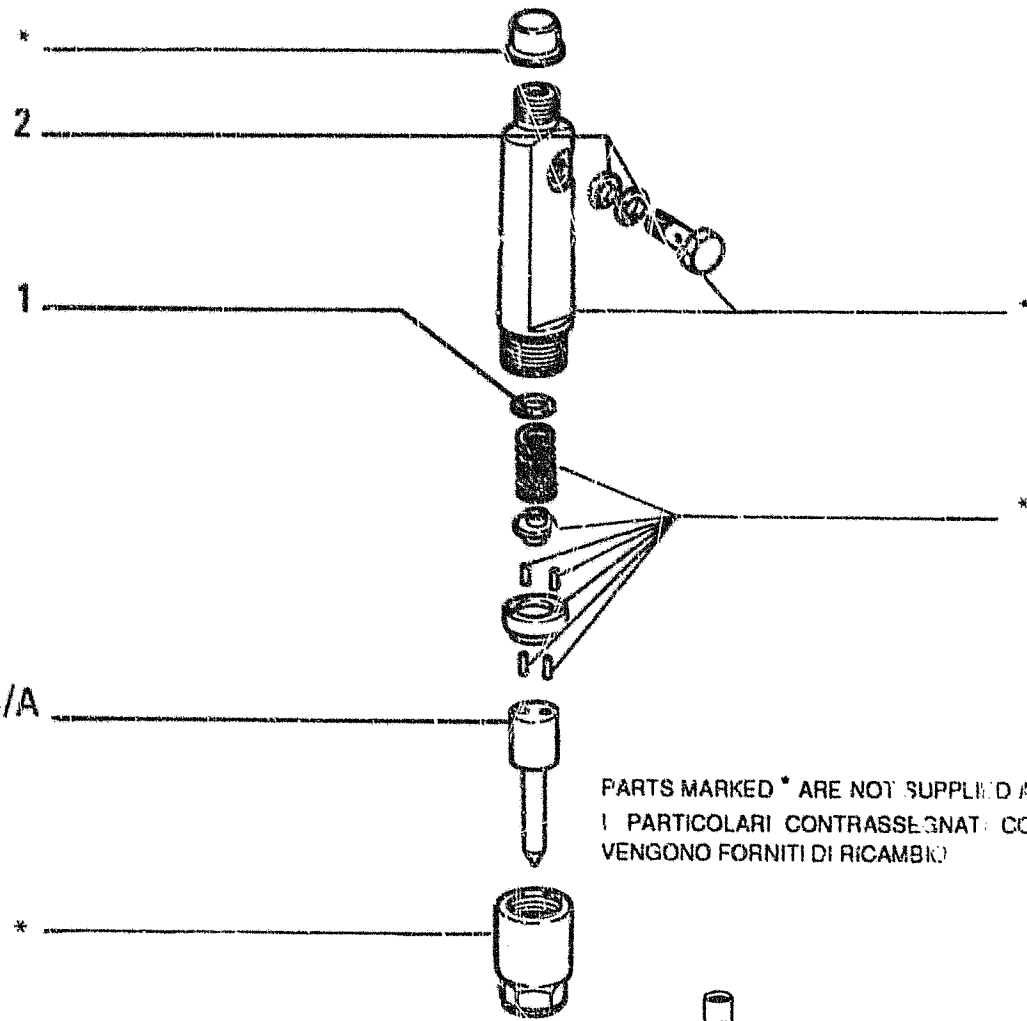

ITEM	PART NUMBER	QTY	TRANS CODE	DESCRIPTION	DESCRIZIONE
1	7906973/3	1	2K	KIT	KIT
2	10297760	2	131R	WASHER	ROSETTA

A2.24/A

D 1572 Tel. n. 250905 →

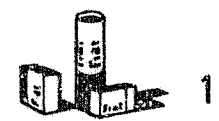

79069718 (OMAP)
NOZZLE HOLDER - PORTAPOLVERIZZATORE - PORTE-INJECTEUR - DUESENHALTER - PORTA-
INYEKTOR

A2 35 2A
N.T.R. 2/00 - 115, 10, 1990
6/4, 04, 08, 1, 05

N16

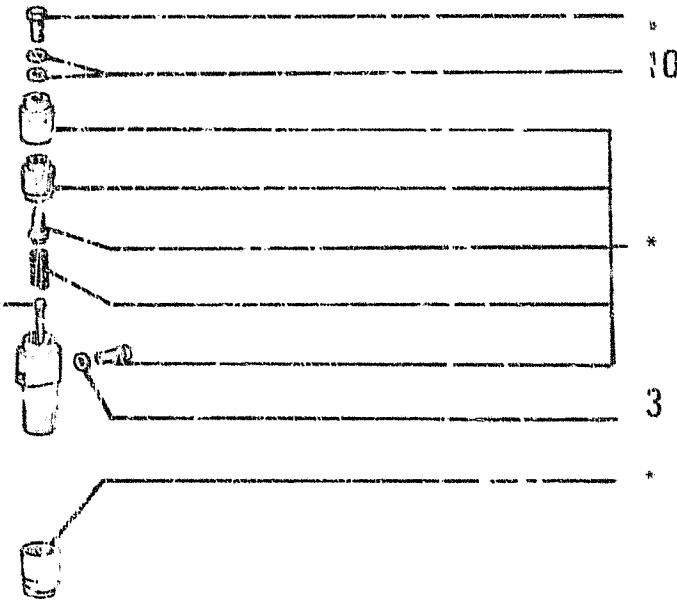

QTY	PART NUMBER	TRANS CODE	DESCRIPTION	DESCRIZIONE
3	79038248	1 131R	WASHER	ROSETTA
10	79038242	2 133R	SEAL	ROSETTA DI TENUTA

PARTS MARKED * ARE NOT SUPPLIED AS SPARES
 I PARTICOLARI CONTRASSEGNA TI CON * NON
 VENGONO FORNITI DI RICAMBIO

C 1572 -> Tel.n. 250904

771065 (BOSCH)

NOZZLE HOLDER - PORTAPOLVERIZZATORE - PORTE INJECTEUR - DUESENHALTER -
 PORTAINJECTOR

A2 35/3

N.T.R. 200 - 15.10.1990

604.01.081.05

N17

	DESIGNAZIONE BASE	BASIC DESIGNATION	DESIGNATIONS-BASES	GRUNDBEZEICHNUNGEN	DE NOMINACIONES BASE
285C	COPPIA DI INGRANAGGI	GEAR SET	COUPLE D'ENGRENA- GES	ZAHNRAOFAAR	PAR DE ENGRANAJES
286C					
286T	TELAIO ANTERIORE	FRONT MAIN FRAME	CHASSIS AVANT	RAHMEN VORN	ARMAZON DELANTERO
287T	TELAIO POSTERIORE	REAR MAIN FRAME	CHASSIS ARRIERE	RAHMEN HINTER	ARMAZON TRASERO
288S	STRUMENTO MULTIPLU	INSTRUMENT CLUSTER	COMBINE DE BORD PLUS INDICAT	KOMBIINSTRUMENT	QUADRO DE INDICACIONES MULTIPL
288T	TROMBA ACOUSTICA	PROJECTOR	TROMPETTE	TROMPETE	TROMPETA
289T	TRATTORE	TRACTOR	TRACTEUR	MASCHINE	TRACTOR
29G1	COMANDI ESTERNI CAMBIO	TRANSMISSION OUTSIDE CONTROL	COMMANDES EXTER BOITE VITESSE	AEUSSERE GETRIEBESCHALTUNG	VARRILAJE CAMBIO VELOCIDADES
29G2	COMANDI ESTERNI RIDUTTORE	LOW SPEED OUTER CONTROLS	COMMANDES EXTER. REDUCTEUR	ZUSATZGETRIEBESCHALTUNG	MANDO DEL REDUCTOR DEL CAMBIO
29G3	DISPOSITIVI SICUREZZA CAMBIO	TRANSMISSION SAFETY DEVICE	BLOCAGE DE BOITE DE VITESSES	GETRIEBESCHALTSPERRE	ENCLAVAMIENTO DEL CAMBIO
29OC	COPRIGIUNTO	FISHPLATE	COUVRE-JOINT	LASCHE	CUBREJUNTAS
29OT	TUBETTO IDENTIFICAVI	CABLE IDENTIF.TUBE			
29IC	COPRIGUARNIZIONE	SEAL COVER	COUVRE-JOINT	HALTER	ABRAZADERA
29IT	TORQUE CONTROL	TORQUE CONTROL			
292C	COPRIPEDALE DI GOMMA	PEDAL RUBBER PAD	GARNITURE CADUTCHOU	FUSSHEBELLEBERZUG	FORRO DE CAUCHO
293C	COPRITAPPO	PLUG COVER	CACHE-BOUCHON	SCHUTZKAPPE	CAPUCHON
294S	SUCCHIERUOLA	SUCTION ROSE	CREPINE	SAUGSIEB	FILTRO DE ASPIRACION
295C	CORNICE	BEZEL	MONTURE	RAHMEN	MARCO
295S	SUGLA	SHOE	PATIN	KETTENPLATTE	ZAPATA
296C	COPRIPULSANTE	BUTTON COVER	CACHE-BOUION	DRUCKKNOFDECKEL	CAPUCHA
297C	CORONA DENTATA	RING GEAR	COUROMNI DENTEE	ZAHNKRANZ	CORONA DENTADA
3G42	CILINDRO POSIZIONATORE	POSITIONER CYLINDER	CYLINDRE POSITION	STELLZYLINDER	
3G44	CILINDRO PENETRAZIONE	PENETRATION CYLINDER	CYLINDRE DE PENETRATION	EINDRINGZYLINDER	
300C	CORPO	BODY	CORPS	GEHAUSE	CUERFO
300S	SUPPORTO	SUPPORT	SUPPORT	TRAEGER	SOPORTE
3007	PNEUMATICI 23.5X25	TIRES 23.5X25	PNEUS 23.5X25	REIFEN 23 5X25	
301S	SUPPORTO ELASTICO	SNUBBER	SUPPORT ELASTIQUE	FEDERTRAEGER	APOYO ELASTICO
3017	PNEUMATICI 20X24	TIRES 20X24		REIFEN 20X24	
302S	SUPPORTO OSCILLANTE	SWIVELING BLOCK	SUPPORT OSCILLANT	KIPPLAGER	APOYO OSCILLANTE
304S	SUPPORTO MASSE CENTRIFUGHE	WEIGHT PLATE	PLAQUE DE MASSE- LOTTE	VERSTELLPLATTE	SOPORTE DEL CON- TRAPESO
304S					
305S	SUPPORTO CON CATADIOTTO	SUPPORT W/REFLEX REFLECTOR	SUPPORT AVEC CATA- DIOPTR	LAGER MIT RUECK- STRAHLER	SOPORTE CON CATA- FAROS
305S					
307C	CORRETORE	CORRECTION	CORRECTEUR	VERSTELLER	CORRECTOR
308C	CORRETORE DI FRENATA	BRAKE COMPENSATOR	REPARTITEUR DE FREINAGE	BREMSVERSTELLER	CORRECTOR DE FRENADO
308C					
310S	SUPPRESSORE FRENI	BRAKE BOOSTER	SURPRESSEUR DE FREINS	DRUCKVERSTELLER	REFORZADOR DE FRENO
312C	CREMAGLIERA	RACK	CREMAILLIERE	ZAHNSTANGE	CREMALLERA
315C	CRISTALLO	GLASS PANE	GLACE	GLASSCHEIBE	CRISTAL
316C	CRISTALLO PROIETTORE	HEADLAMP LENS	GLACE DE PRO- JECTEUR	STREUSCHEIBE	CRISTAL DE PRO- VECTOR

DESIGNAZIONE BASE	BASIC DESIGNATION	DESIGNATIONS-BASES	GRUNDBEZEICHNUNGEN	DENOMINACIONES BASE
232P	PUNTALE	PUSH ROD	EMBOUT	HERRETE
238P	PUNTELLO	STAY	BEQU'LE	PUNTAL
246G4	TUBAZIONI TRASM.IDROSTATICA	HYDROSTATIC DRIVE SYSTEM LINES		
249P	PUNTERIA	TAPPET	POUSSOIR	PERNIO ARTICULADO
241P	PUNTERIA A RULLO	ROLLER TAPPET	POUSSOIR A GALET	EMPUJADOR DE RODILLO
231P				
242P	PUNTA DENTE RIPPER	RIPPER SHANK POINT	POINTE DENT SCARIFICATEUR	PUA DE DIENTE RIPPER
244P	PUNTONE	STRUT	EYAI	LISTON
245C	CONTACHILOMETRI	SPEEDOMETER - KM	COMPTEUR KILOMETRIQUE	CUENTAKILOMETROS
245C				
246C	CONTAMIGLIA	SPEEDOMETER-MILES	COMPTEUR DE MILLES	CUENTAMILLAS
247C	CONTAGIRI	TACHOMETER	COMPTE-TOURS	CUENTAREVOLUCIONES
248C	CONTAGRE	HOURLMETER	HOROMETR.	CUENTAHORAS
248P	PUNZONE	PUNCH	POINCON	PUNZON
25GA	INNESTO TRASMISSIONE	ENGINE/TRANSMISSION COUPLING		
25G1	COLLEGAMENTI CAMBIO	TRANSMISSION CONNECTING	CONNECTIONS DE BOITE VITESSES	
250C	CONTATTO	CONTACT	CONTACT	CONTACTO
254C	CONTENITORE	CONTAINER	CONTAINER	RECIPIENTE
255C	CONTENITORE FILTRO	FILTER SHELL	CUVE DE FILTRE	CAMISA DE FILTRO
257C	CONTRODADO	LOCK NUT	CONTRE-ECROU	CONTRATUERCA
259C	CONVERTITORE DI COPPIA	TORQUE CONVERTER	CONVERTISSEUR DE COUPLE	CONVERTIDOR
260C	CONVOGLIATORE	SHROUD	CONVOYEUR	CANALIZADOR
265C	COPERCHIO	COVER	COUVERCLE	TAPA
270C	COPIGLIA	COTTER PIN	COUPILLE	CHAVETA PARTIDA
271S	STATORE	STATOR	STATOR	ESTATOR
271C	COPPA OLIO	OIL SUMP	CARTER A HUILE	CARTER DE ACEITE
274S	STELO	ROD	TIGE	VASTAGO
275C	COPPA	SUMP	CARTER A HUILE	CARTER DE ACEITE
275S	STERZO	STEERING	DIRECTION	DIRECCION
278C	COPPA DELLA RUOTA	WHEEL CAP	ENJOLIVEUR DE ROUE	EMBELLECEDOR DE RUEDA
278C				
279C	COPPA RACCOGLIOLIO	OIL SHIELD	COLLECTEUR D HUILE	RETENEDOR DE ACEITE
279C				
28G8	DISPOSITIVO LUBRIFIC.CAMBIO	TRANS.LUBRICATION SYSTEM	DISP LUBRIFIC.BOITE VITESSE	GETRIEBESCHMIERSYSTEM
280S	STOPPING	WICK	MECHE	SCHMIERDOCHT
282T	TARCA MANUTENZIONE	SERVICE AND LUBE INSTRUCTION	DECALCOMANIE ENTRETIEN	ABZIEHBILD BETRIEBSANLEITUNG WINKELS
283T	TARGHETTA IDENTIFICAZIONE	IDENTIFICATION PLATE	PLAQUETTE RECAPITULATIVE	TYPENSCHILD
284T	TERGICRISTALLO POSTERIORE	WINDSCREEN WIPER	ESSUIE-GLACE	SCHIBENWISCHERHINTER
285C	COPPIA CONICA	BEVEL BEAR SET	COUPLE CONIQUE	TELLER UND KEGELRAD
285T	TUBO FLESSIBILE	HOSE	TUYAU FLEXIBLE	SCHLAUCH

DESIGNAZIONE BASE	BASIC DESIGNATION	DESIGNATIONS-BASES	GRUNDBEZEICHNUNGEN	DENOMINACIONES BASE
210C	COMMUTATORE	SWITCH	COMMUTATEUR	CONMUTADOR
210P	PRIGIONIERO	STUD	GOUJON	ESPARRAGO
210T	TURBOCOMPRESSORE	TURBOCHARGER	TURBOCOMPRESSEUR	TURBOCOMPRESOR
211T	TUTA	OVERALL	COMBINAISON	MONO DE MECANICO
214C	COMPRENDE	INCLUDES	COMPRENDE	COMPRENDE...
215P	PROFILATO	CHANNEL	PROFILE	PERFIL
215S	SQUADRETTA	CONNECTING PLATE	EQUERRE	ESCUADRA
216C	COMPRESSORE ARIA	AIR COMPRESSOR	COMPRESSEUR D AIR	COMPRESOR
216P	PROFILATO DI GOMMA	RUBBER SECTION	PROFILLE CAOUTCHOUC	PERFIL DE GOMA
218P	PROIETTORE A TRE LUCI	THREE-LIGHT HEADLAMP	PROJECTEUR A TROIS FEUX	PROYECTOR DE TRES LUCES
218P				
220G	ROTAZIONE RETROSCAVATORE	BACKHOE ROTATION	ROTATION PELLE RETRO	ROTACION RETROEXCAVADORA
220C	CONDENSATORE	CONDENSER	CONDENSATEUR	CONDENSADOR
220P	PROIETTORE	FLOODLIGHT	PROJECTEUR	PROYECTOR
220S	STABILIZZATORE	STABILIZER	STABILISATEUR	ESTABILIZADOR
221C	CONDIZIONATORE	AIR CONDITIONER	CLIMATISEUR	CLIMATIZADOR
221P	PROIETTORE SDOPPIATO	DUAL HEADLAMP	PROJECTEUR JUMELE	PROYECTORES GEMELOS
221P				
222P	PROLUNGA	EXTENSION	RALLONGE	EXTENSION
223C	CONDOTTO	DUCT	CONDUIT	CONDUCTO
223P	PROLUNGA PER GONFIAGGIO	TIRE INFLATION EXTENSION	RALLONGE DE GONFLAGE	EXTENSION DE MANGUERA
223P				
223P				
224C	CONDOTTO ARIA	AIR DUCT	CONDUIT D AIR	CONDUCTO DE AIRE
224P	PROTEZIONE	SHIELD	PROTECTION	DEFENSA
225C	COLLETTORE ASPIRAZIONE	INTAKE MANIFOLD	CONDUIT D ADMISSION	COLECTOR DE ASPIRACION
225S	STAFFA	BRACKET	ETRIER	ESTRIBO
226S	STAFFA AD U	U-BOLT	ETRIER PROFILE EN U	BRIDA DE SECCION EN U
226S				
2363	PEDALIERA	PEDAL CONTROL		
2365	TUBAZIONI COMANDO TRASM. IDR.	TRANSMISSION CONTROL LINES		
230C	COLLETTORE DI SCARICO	EXHAUST MANIFOLD	CONDUIT D ECHAPPEMENT	COLECTOR DE ESCAPE
230P	PULEGIA	PULLEY	POULIE	POLEA
230V	VOLTAMPEROMETRO	VOLTAMMETER	VOLTAMPEROMETRE	VOLTAMPERIMETRO
231S	STAFFETTA	CLIP	COLLIER	ABRAZADERA
231V	VERNICE	PAINT	PEINTURE	PINTURA
235C	CONNESSIONE	CONNECTION	CONNEXION	CONEXION
235S	STANTUFFO	PISTON	PISTON	EMBOLO
236P	PULSANTE	PUSH BUTTON	BOITON	PULSADOR
237P	PULSANTIERA	SWITCH PANEL	CLAVIER	DECLADO

A

ENGINE • MOTOFIE • MOTEUR • MOTOR • MOTOR

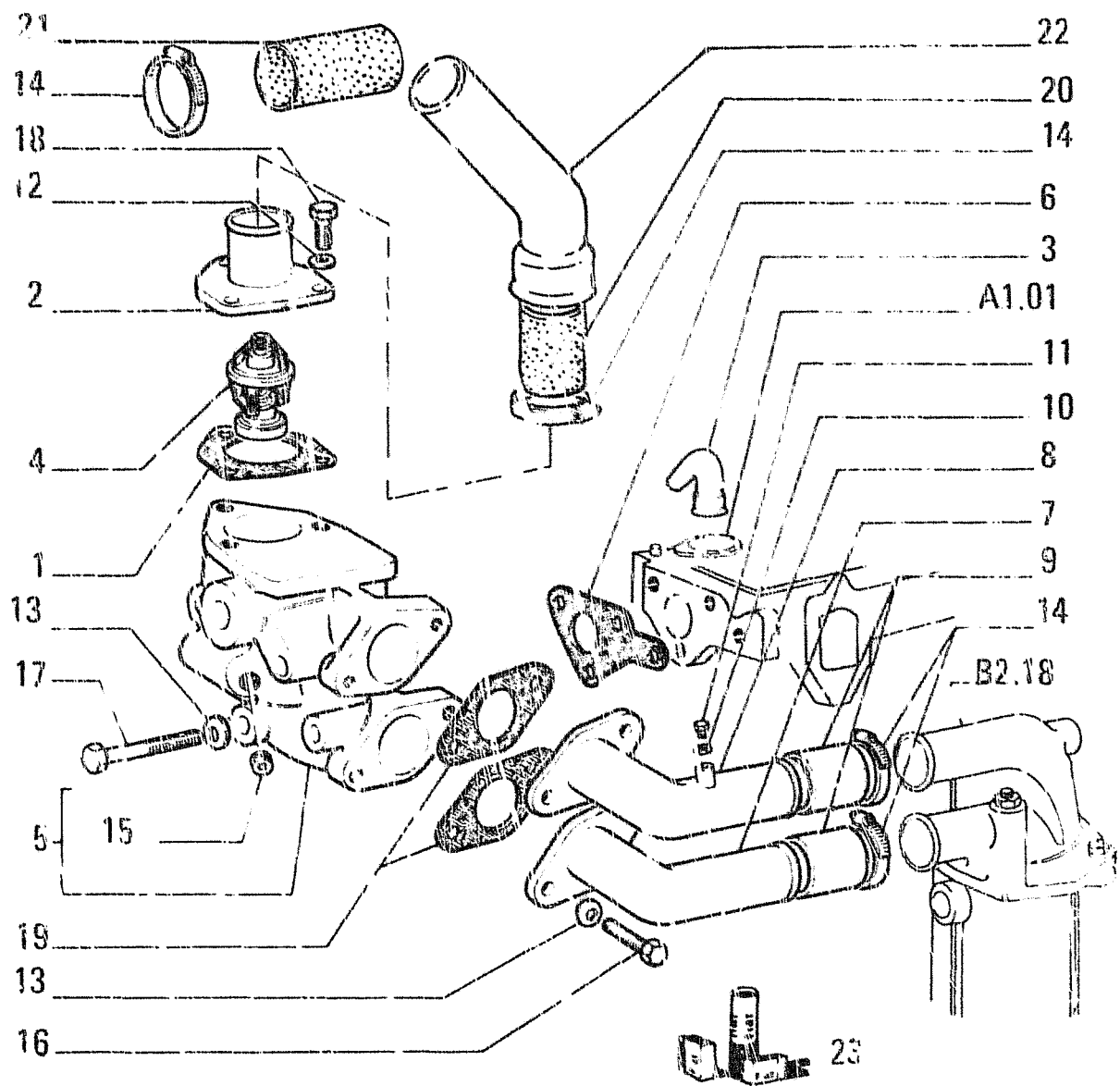

ITEM	PART NUMBER	QTY	TRANS CODE	DESCRIPTION	DESCRIZIONE
1	4599809	1	123G	SEAL ASSY	GUARNIZIONE TENUTA FRONTALE
2	4661543	1	193T	TUBE	TUBO RIGIDO
3	4699155	6	2CD	DEFLECTOR	DEFLETTORI
4	4703088	1	96T	THERMOSTAT	TERMOSTATO
5	4727975	1	186C	MANIFOLD - ASSEMBLY C1572	COLLETTORE - COMPLETO C1572
	4790882	1	20R	FITTING - ASSEMBLY D1572	RACCORDO - COMPLETO D1572
6	4728639	1	133R	SEAL C1572	ROSETTA DI TENUTA C1572
	4770265	1	123G	SEAL ASSY D1572	GUARNIZIONE TENUTA FRONTALE D1572
		1	122G	SEAL C3342	GUARNIZIONE C3342
	4848560	1	122G	SEAL D3342	GUARNIZIONE D3342
7	4733736	2	193T	TUBE C1572	TUBO RIGIDO C1572
	4795702	1	193T	TUBE D1572	TUBO RIGIDO D1572
8	4765392	1	193T	TUBE C1572	TUBO RIGIDO C1572
	4795704	1	193T	TUBE D1572	TUBO RIGIDO D1572
9	10138386	2	30M	SLEEVE 45x60	MANICOTTO 45x60
10	10280060	1	133R	SEAL 14,2x20 C1572	ROSETTA DI TENUTA 14,2x20 C1572
11	10300611	1	50T	PLUG 14x1,5x9 C1572	TAPPO 14x1,5x9 C1572
	10324911	1	50T	PLUG 14x1,5x13 D1572	TAPPO 14x1,5x13 D1572
12	11193871	3	132R	LOCKWASHER 8,4x16	ROSETTA DI SICUREZZA 8,4x16
13	11190571	4	131R	WASHER 10,5x20 D1572	ROSETTA 10,5x20 D1572
	11198371	4	132R	LOCKWASHER 10,5x20	ROSETTA DI SICUREZZA 10,5x20
		3	132R	LOCKWASHER 10,5x20 C1572	ROSETTA DI SICUREZZA 10,5x20 C1572

WATER PUMP AND LINES - POMPA ACQUA E TUBAZIONI - POMPE ET CANALISATIONS D'EAU -
WASSERPUMPE UND LEITUNGEN- BOMBA DE AGUA Y TUBERÍAS

A4.02 1
R.T.R. 200 - 15.10.1990
604.01.081.05

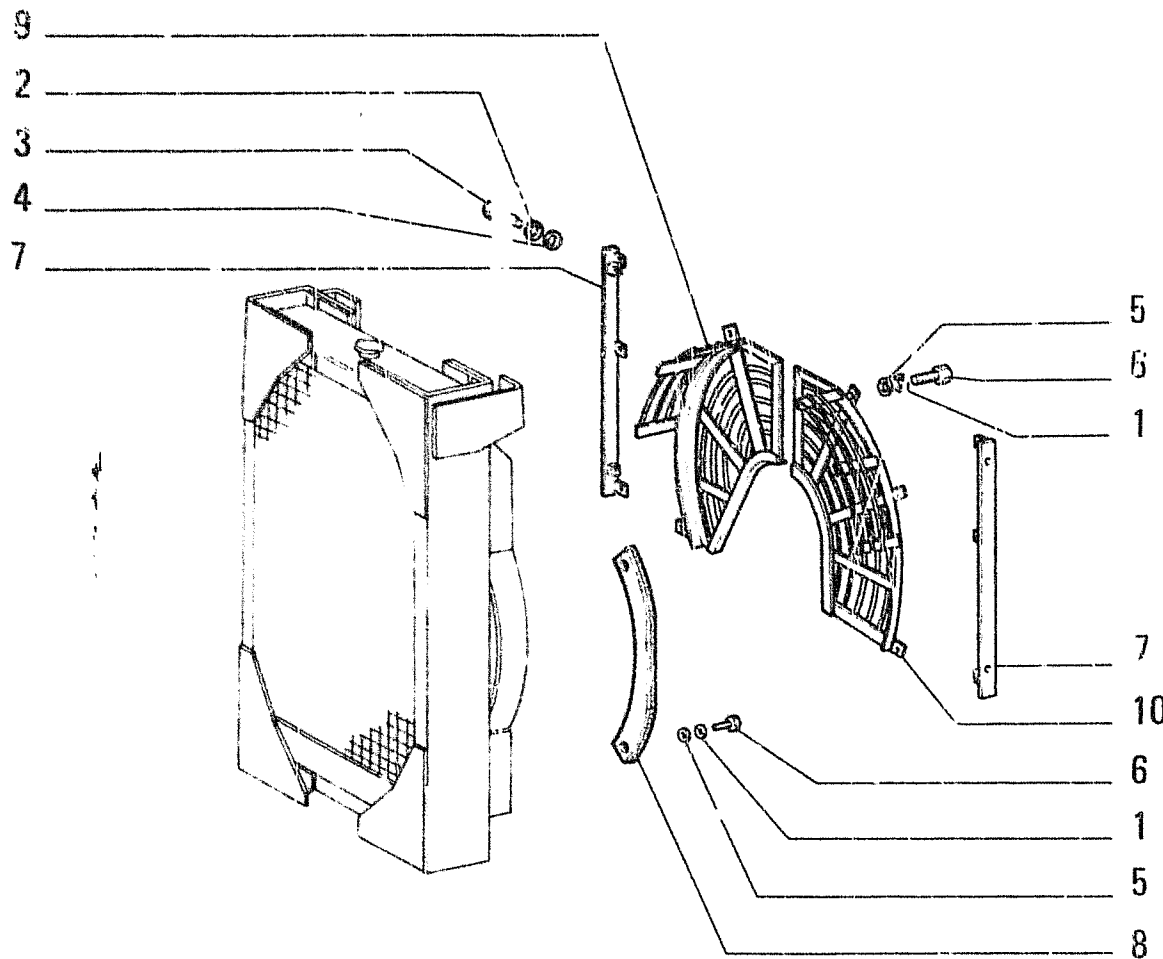

ITEM	PART NUMBER	QTY	TRANS CODE	DESCRIPTION	DESCRIZIONE
1	10516671	11	132R	LOCKWASHER 8,1x2,2	ROSETTA DI SICUREZZA 8,1x2,2
2	10516871	4	132P	LOCKWASHER 10x2,5	ROSETTA DI SICUREZZA 10x2,5
3	11106231	4	40V	SCREW 10x1,5x25	VITE 10x1,5x25
4	12638621	4	131R	WASHER 10,2x18	ROSETTA 10,2x18
5	12646721	11	131R	WASHER 8,15x20	ROSETTA 8,15x20
6	16043331	11	40V	SCREW 8x1,25x18	VITE 8x1,25x18
7	79028069	2	225S	BRACKET	STAFFA
8	79035023	2	123G	SEAL ASSY	GUARNIZIONE TENUTA FRONTALE
9	76010549	1	101G	GRID - RIGHT D1510	GRIGLIA - DESTRO D1510
	79037699	1	101G	GRID - RIGHT C1510	GRIGLIA - DESTRO C1510
10	76010554	1	101G	GRID - LEFT D1510	GRIGLIA - SINISTRO D1510
	79037706	1	101G	GRID - LEFT C1510	GRIGLIA - SINISTRO C1510

RADIATOR - RADIATORE - RADIATEUR - KUEHLER - RADIADOR

A4.01

3

N.T.R. 158 - 13.03.1987
604.01.081.03

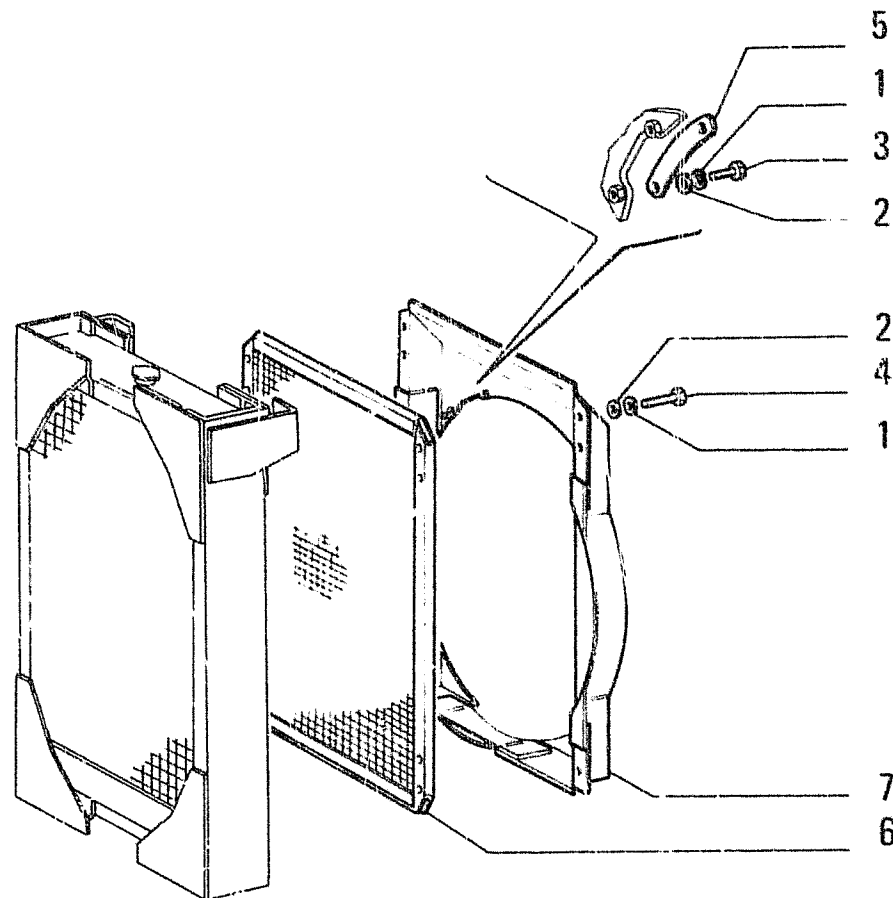

ITEM	PART NUMBER	QTY	TRANS CODE	DESCRIPTION	DESCRIZIONE
1	10516671	8	132R	LOCKWASHER 8,1x2,2	ROSETTA DI SICUREZZA 8,1x2,2
2	12646721	8	131R	WASHER 8,15x20	ROSETTA 8,15x20
3	16043331	2	40V	SCREW 8x1,25x18	VITE 8x1,25x18
4	16043531	8	40V	SCREW 8x1,25x22	VITE 8x1,25x22
5	79035026	1	70T	PROTECTIVE PANEL	TEGOLO
6	79037695	1	100G	RADIATOR GRILLE	GRIGLIA DEL RADIATORE
7	76010546	1	260C	SHROUD D1510	CONVOGLIATORE D1510
	79037745	1	260C	SHROUD C1510	CONVOGLIATORE C1510

RADIATOR - RADIATORE - RADIATEUR - KUEHLER - RADIADOR

A4.01 2

N.T.R. 158 - 13.03.1987
604.01.081.03

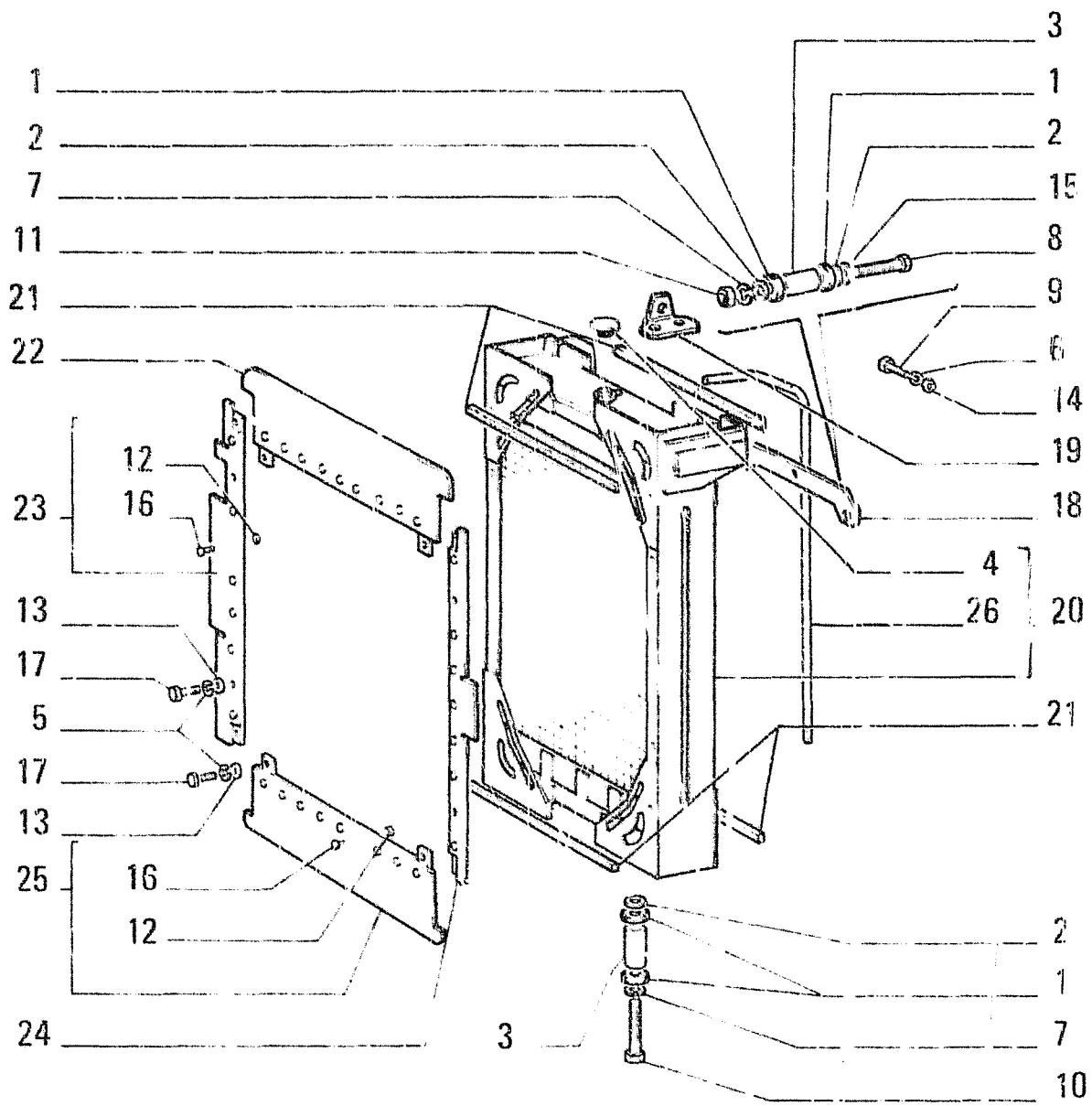

FIATALLIS FD7

A4.01 TAV. 1 PAG.2

ITEM	PART NUMBER	QTY	TRANS CODE	DESCRIPTION	DESCRIZIONE
25	79037744	1	120G	GASKET - LOWER ASSEMBLY	GUARNIZIONE PIANA - INFERIORE COMPLETO
26	19022986	L	285T	HOSE M.1,100 D3446	TUBO FLESSIBILE M.1,100 D3446

RADIATOR - RADIATORE - RADIATEUR - KUEHLER - RADIADOR

A4.01

1

N.T.R. 205 - 30.09.1991
604.01.081.06

0-5

UNA

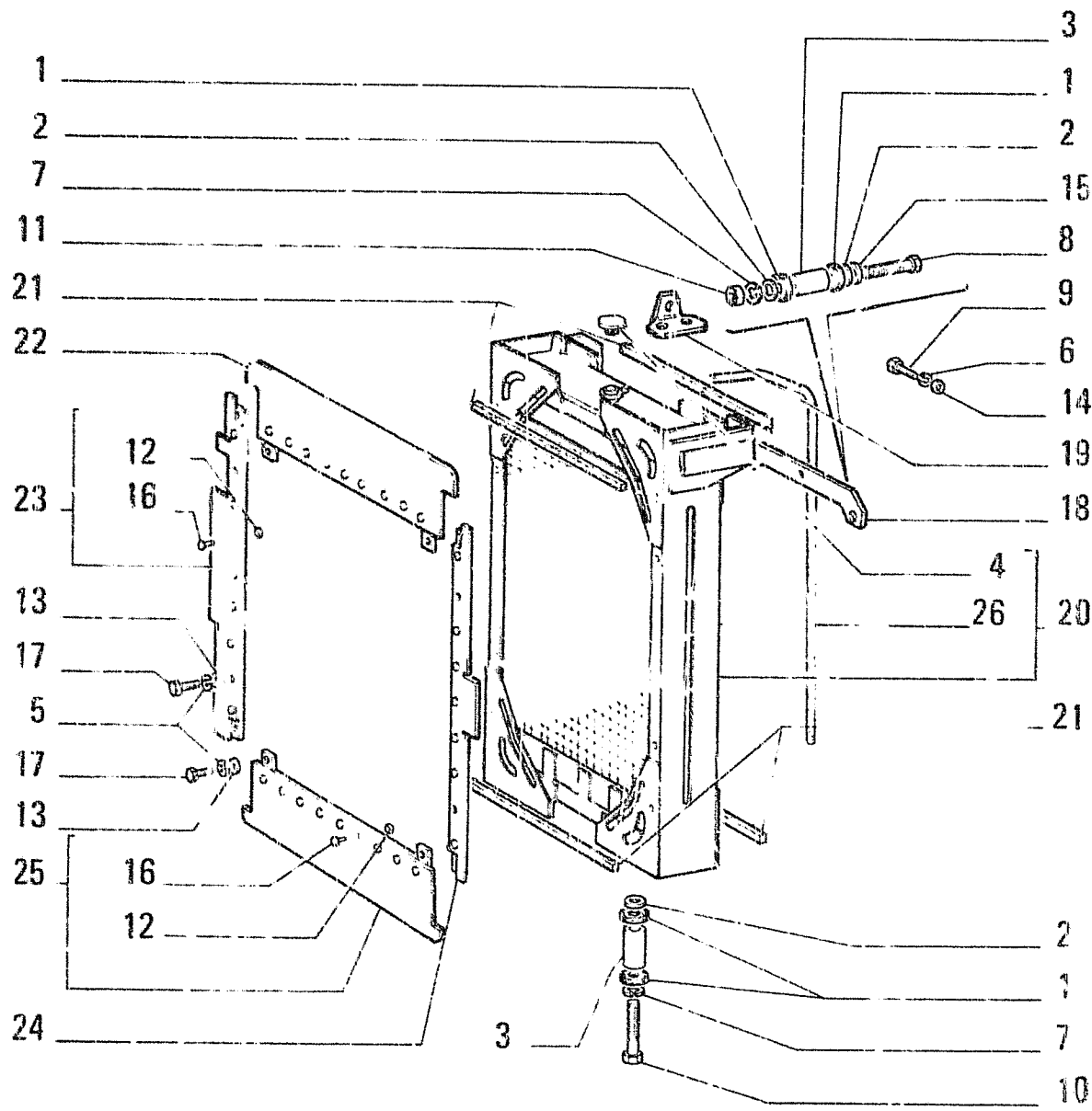

FIATALLIS FD7

ITEM	PART NUMBER	QTY	TRANS CODE	DESCRIPTION	DESCRIZIONE
1	741569	8	61T	CUSHION PAD	TASSELLO ELASTICO
2	741570		131R	WASHER	ROSETTA
3	741571	4	75D	SPACER	DISTANZIALE
4	4959324	1	50T	PLUG	TAPPO
5	10516671	8	132R	LOCKWASHER 8,1x2,2	ROSETTA DI SICUREZZA 8,1x2,2
6	10516871	2	132R	LOCKWASHER 10x2,5	ROSETTA DI SICUREZZA 10x2,5
7	10517071	5	132R	LOCKWASHER 12,2x3,1	ROSETTA DI SICUREZZA 12,2x3,1
8	11106231	2	40V	SCREW 10x1,5x25	VITE 10x1,5x25
9	11112431	2	40V	SCREW 12x1,75x30	VITE 12x1,75x30
10	11113731	3	40V	SCREW 12x1,75x75	VITE 12x1,75x75
11	11702921	4	10D	NUT 12x1,75x10	DADO 12x1,75x10
12	12644401	30	131R	WASHER 6,15x15	ROSETTA 6,15x15
13	12646721	8	131R	WASHER 8,15x20	ROSETTA 8,15x20
14	12646821	2	131R	WASHER 10,2x25	ROSETTA 10,2x25
15	12646921	4	131R	WASHER 12,2x28	ROSETTA 12,2x28
16	13868350	30	55R	RIVET 5x12	RIBATTINO 5x12
17	16043531	8	40V	SCREW 8x1,25x22	VITE 8x1,25x22
18	79017912	1	225S	BRACKET	STAFFA
19	79017913	1	80M	BRACKET	MENSOLA
20	79022096	1	25R	RADIATOR - ASSEMBLY	RADIATORE - COMPLETO
21	79035017	4	120G	GASKET	GUARNIZIONE PIANA
22	79037738	1	120G	GASKET - UPPER ASSEMBLY	GUARNIZIONE PIANA - SUPERIORE COMPLETO
23	79037740	1	120G	GASKET - SIDE RIGHT ASSEMBLY	GUARNIZIONE PIANA - LATERALE DESTRO COMPLETO
24	79037742	1	120G	GASKET - SIDE LEFT ASSEMBLY	GUARNIZIONE PIANA - LATERALE SINISTRO COMPLETO

RADIATOR - RADIATORE - RADIATEUR - KUEHLER - RADIADOR

A4.01

1

N.T.R. 205 - 30.03.1991
604.01.081.06

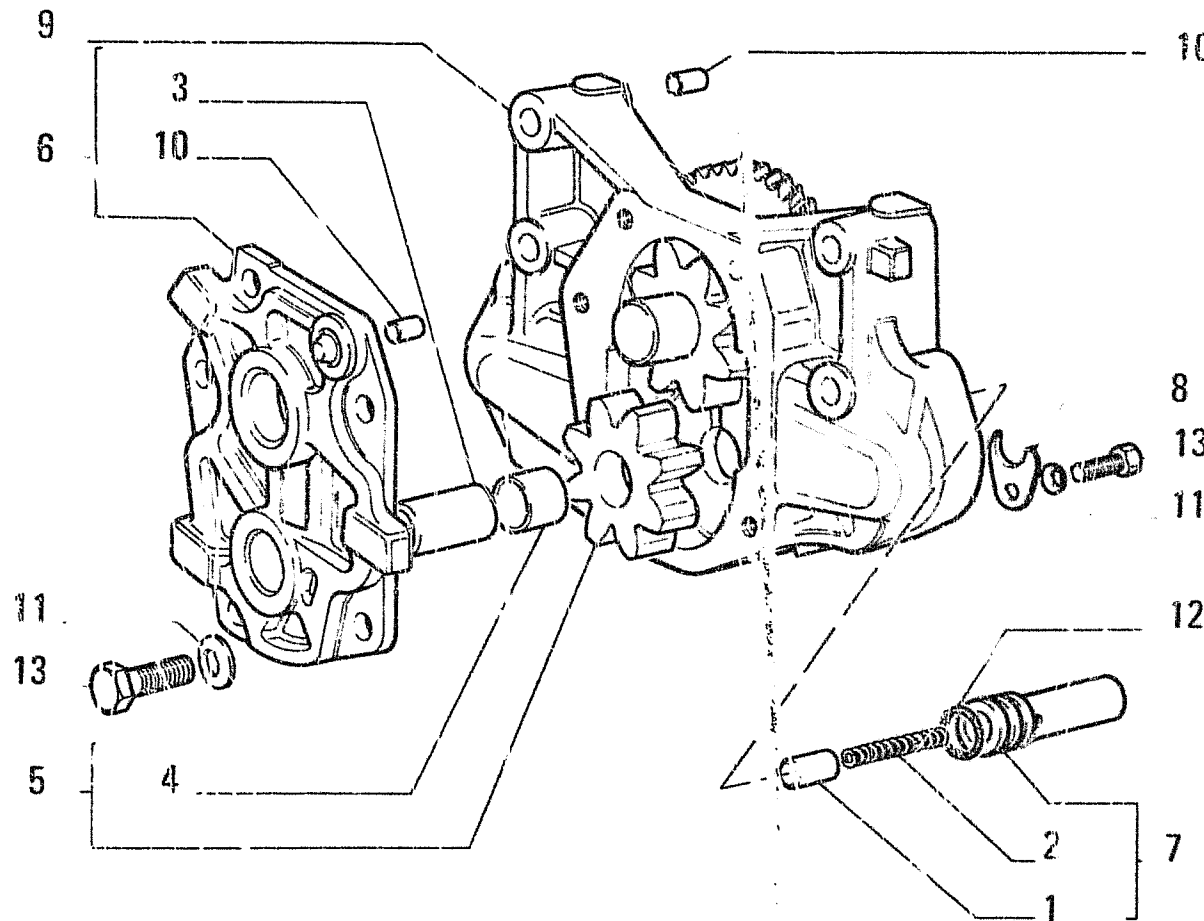

ITEM	PART NUMBER	QTY	TRANS CODE	DESCRIPTION	DESCRIZIONE
1	4587730	1	10V	VALVE	VALVOLA
2	4587731	1	100M	SPRING	MOLLA
3	4613290	1	80P	PIN C1572	PERNO C1572
	4770259	1	80P	PIN D1572	PERNO D1572
4	4613292	1	95B	BUSHING C1572	BOCCOLA C1572
5	4613293	1	50I	GEAR - ASSEMBLY C1572	INGRANAGGIO - COMPLETO C1572
	4770262	1	50I	GEAR - ASSEMBLY D1572	INGRANAGGIO - COMPLETO D1572
6	4613351	1	265C	COVER - ASSEMBLY C1572	COPERCHIO - COMPLETO C1572
	4770254	1	265C	COVER - ASSEMBLY D1572	COPERCHIO - COMPLETO D1572
7	4613352	1	10V	VALVE - ASSEMBLY	VALVOLA - COMPLETO
8	4613353	1	85F	YOKE	FORCELLA
9	4699372	1	300C	BODY C1572	CORPO C1572
	4770253	1	300C	BODY D1572	CORPO D1572
10	10839610	3	90G	DOWEL 8x12	GRANO 8x12
11	4799587	5	131R	WASHER D1572	ROSETTA D1572
	11198071	5	132R	LOCKWASHER 8,2x15 C1572	ROSETTA DI SICUREZZA 8,2x15 C1572
12	14457281	1	158G	O-RING 2,62x15,54	GUARNIZIONE O-R 2,62x15,54
13	16043421	5	40V	SCREW 8x1,25x20	VITE 8x1,25x20

4699371 - 4770250

OIL PUMP - POMPA OLIO - POMPE HUILE -- OELPUMPE - BOMBE DE ACETE

1

A3.02

N.T.R. 158 - 13.03.1987

604.01.081.03

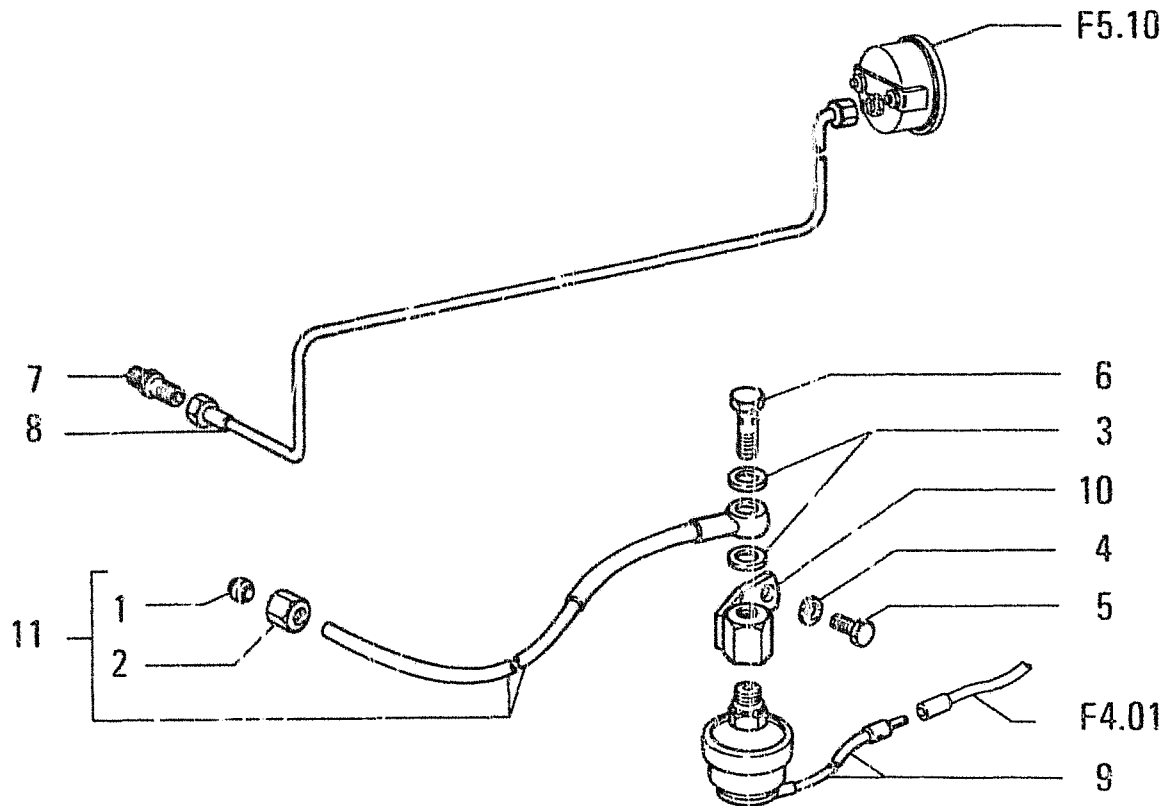

ITEM	PART NUMBER	QTY	TRANS CODE	DESCRIPTION	DESCRIZIONE
1	10165340	1	45A	RING 6,6x7 D1510	ANELLO 6,6x7 D1510
2	10166040	1	10D	NUT 10x1x12 D1510	DADO 10x1x12 D1510
3	10298360	2	120G	GASKET 10,2x16 D1510	GUARNIZIONE PIANA 10,2x16 D1510
4	10571871	1	170R	LOCKWASHER 10,2x2,2 D1510	ROSETTA EL. 10,2x2,2 D1510
5	11106031	1	40V	SCREW 10x1,5x20 D1510	VITE 10x1,5x20 D1510
6	11003817	1	20R	FITTING 10x1,25x19 D1510	RACCORDO 10x1,25x19 D1510
7	79017116	1	20R	FITTING	RACCORDO
8	79043369	1	193T	TUBE C1510	TUBO RIGIDO C1510
9	79051198	1	160T	SENDING UNIT ENGINE OIL PRESSURE D1510	TRASMETTITORE ENGINE OIL PRESSURE D1510
10	79053317	1	300S	SUPPORT D1510	SUPPORTO D1510
11	79053347	1	193T	TUBE - ASSEMBLY D1510	TUBO RIGIDO - COMPLETO D1510

ENGINE LUBRICATION - LUBRIFICAZIONE MOTORE - GRAISSAGE DU MOTEUR - MOTORSCHMIERUNG -
ENGRASE DEL MOTOR

A3.01

3

N.T.R. 158 - 13.03.1987
604.01.081.03

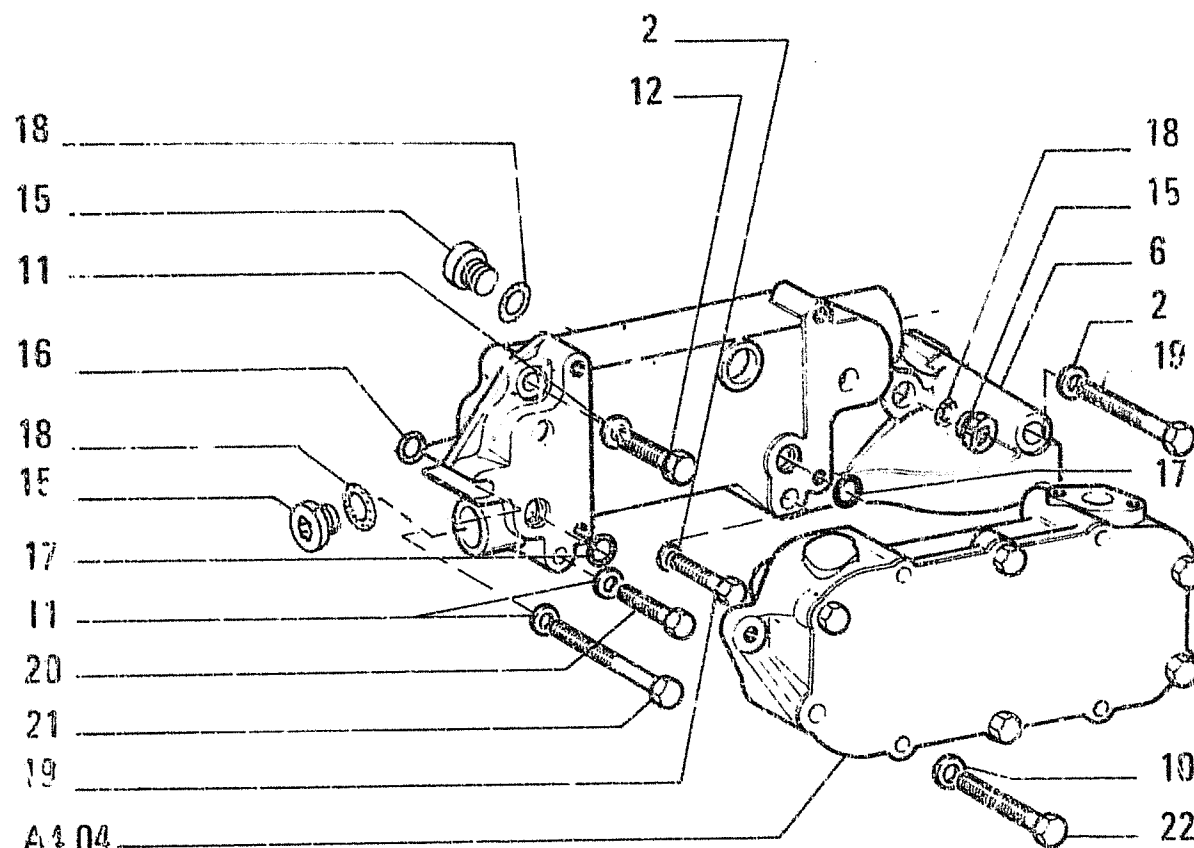

ITEM	PART NUMBER	QTY	TRANS CODE	DESCRIPTION	DESCRIZIONE
2	11198671	3	131R	WASHER 13x24	ROSETTA 13x24
6	4763099	1	300S	SUPPORT	SUPPORTO
10	11193871	4	131R	WASHER 8,4x16	ROSETTA 8,4x16
11	11198371	3	131R	WASHER 10,5x20	ROSETTA 10,5x20
12	11234721	1	40V	SCREW 10x1,25x45	VITE 10x1,25x45
15	10273111	4	50T	PLUG 18x1,5x10	TAPPO 18x1,5x10
16	14457481	3	158G	O-RING 2,62x18,72	GUARNIZIONE O-R 2,62x18,72
17	14457581	2	158G	O-RING 2,62x20,29	GUARNIZIONE O-R 2,62x20,29
18	10263160	4	122G	SEAL 18,2x24	GUARNIZIONE 18,2x24
19	15540721	3	40V	SCREW 12x1,25x45	VITE 12x1,25x45
20	11306921	1	40V	SCREW 10x1,25x30	VITE 10x1,25x30
21	15971921	1	40V	SCREW 10x1,25x105	VITE 10x1,25x105
22	16044821	4	40V	SCREW 8x1,25x80	VITE 8x1,25x80

A4.04

D 1572 Tel. n. 250905 →

ENGINE LUBRICATION - LUBRIFICAZIONE MOTORE - GRAISSAGE DU MOTEUR - MOTORSCHMIERUNG -
 ENGRASE DEL MOTOR

A3.01

2A

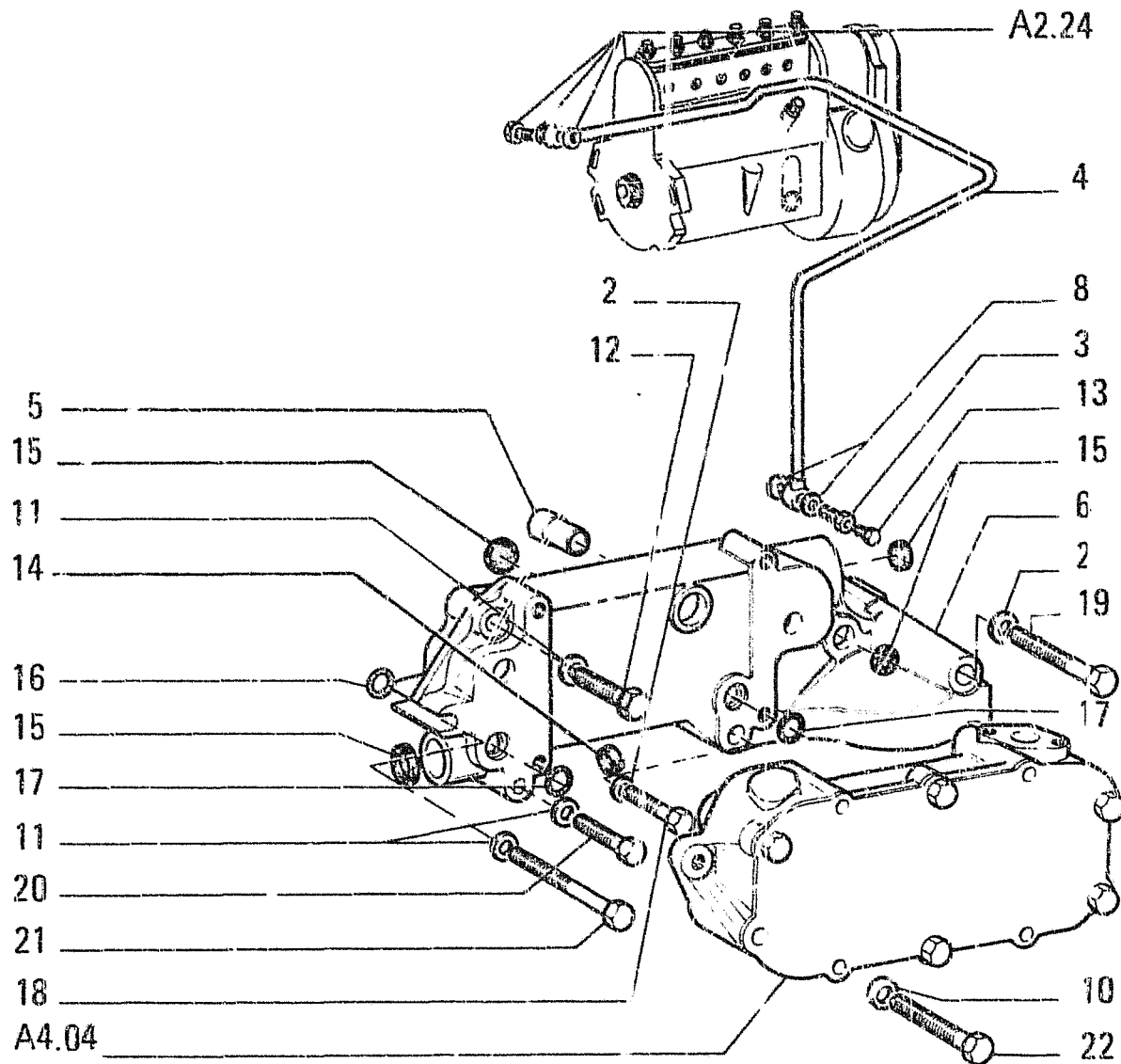

ITEM	PART NUMBER	QTY	TRANS CODE	DESCRIPTION	DESCRIZIONE
2	4585990	3	131R	WASHER	ROSETTA
3	4607792	1	20R	FITTING	RACCORDO
4	4653346	1	193T	TUBE	TUBO RIGIDO
5	4724554	1	193T	TUBE	TUBO RIGIDO
6	4757576	1	300S	SUPPORT	SUPPORTO
8	10298360	2	133R	SEAL 10,2x16	ROSETTA DI TENUTA 10,2x16
10	11198071	4	131R	WASHER 8,2x15	ROSETTA 8,2x15
11	11198371	3	131R	WASHER 10,5x20	ROSETTA 10,5x20
12	11234721	1	40V	SCREW 10x1,25x45	VITE 10x1,25x45
13	11902111	1	50T	PLUG 10x1,25x12	TAPPO 10x1,25x12
14	14328501	1	50T	PLUG 16x5	TAPPO 16x5
15	14328701	5	50T	PLUG 20x6	TAPPO 20x6
16	14457481	3	158G	O-RING 2,62x18,72	GUARNIZIONE O-R 2,62x18,72
17	14457581	2	158G	O-RING 2,62x20,29	GUARNIZIONE O-R 2,62x20,29
18	15541021	1	40V	SCREW 12x1,25x60	VITE 12x1,25x60
19	15541521	2	40V	SCREW 12x1,25x90	VITE 12x1,25x90
20	15888721	1	40V	SCREW 10x1,25x55	VITE 10x1,25x55
21	15972121	1	40V	SCREW 10x1,25x115	VITE 10x1,25x115
22	16044721	4	40V	SCREW 8x1,25x75	VITE 8x1,25x75

C 1572 → Tel.n. 250904

ENGINE LUBRICATION - LUBRIFICAZIONE MOTORE - GRAISSAGE DU MOTEUR - MOTORSCHMIERUNG - ENGRASE DEL MOTOR

A3.01

2

N.T.R. 205 - 30.09.1991
604.01.081.06

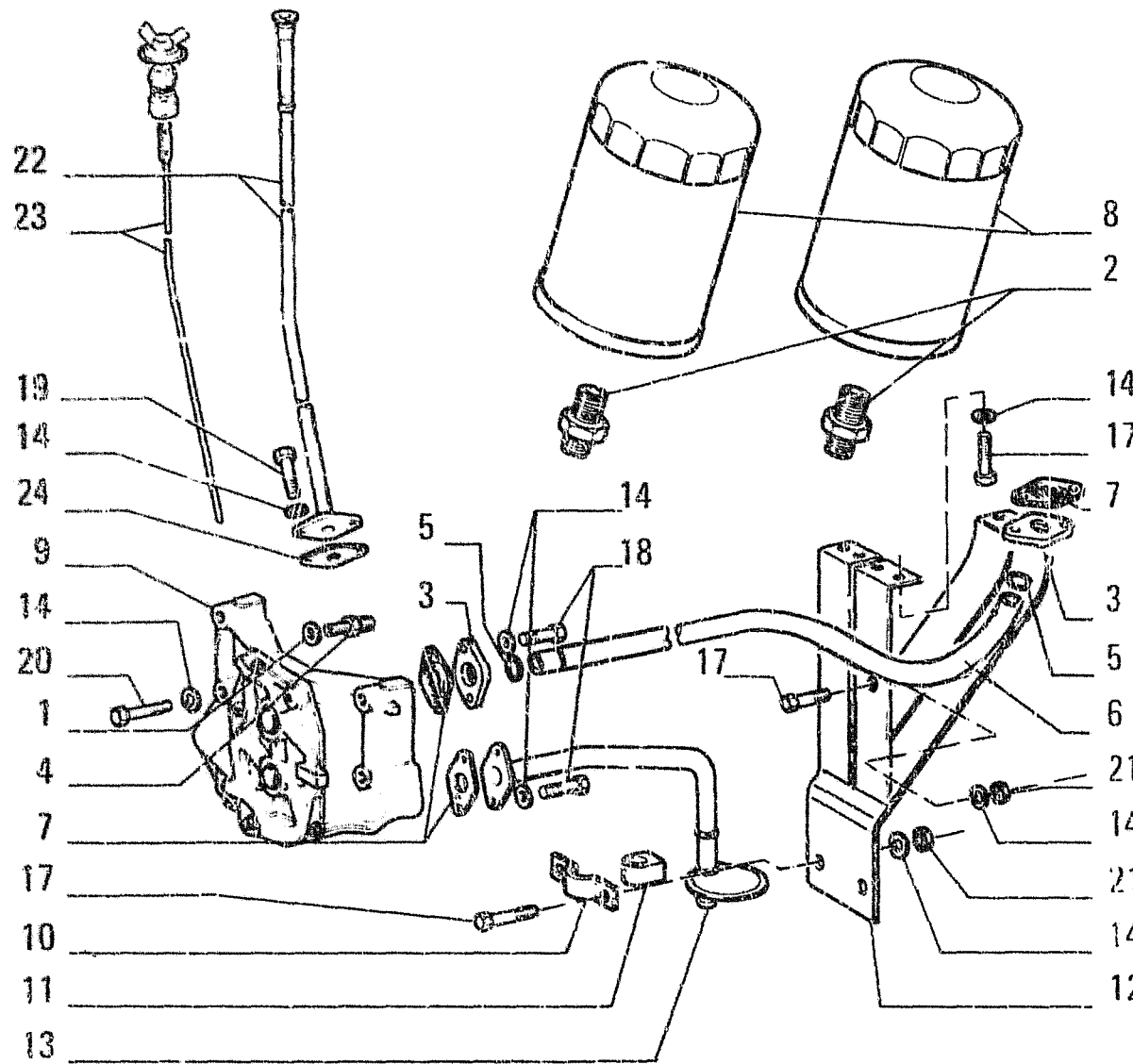

ITEM	PART NUMBER	QTY	TRANS CODE	DESCRIPTION	DESCRIZIONE
1	561293	1	158G	O-RING	GUARNIZIONE O-RING
2	4782453	2	20R	FITTING	RACCORDO
3	4773265	2	20R	FITTING	RACCORDO
4	4785501	1	20R	FITTING	RACCORDO
5	14457681	4	158G	O-RING 2,62x21,89	GUARNIZIONE O-RING 2,62x21,89
6	4773064	1	193T	TUBE	TUBO RIGIDO
7	4617482	3	123G	SEAL ASSY C3341	GUARNIZIONE TENUTA FRONTALE C3341
	4858083	3	122G	SEAL D3341	GUARNIZIONE D3341
8	4630787	2	20E	FILTERING ELEMENT	ELEMENTO FILTRANTE
9	4770250	1	153P	OIL PUMP - ASSEMBLY SEE SGR. A3.02	POMPA OLIO - COMPLETO VEDERE SGR. A3.02
10	4719705	1	231S	CLIP	STAFFETTA
11	4719706	1	30M	SLEEVE	MANICOTTO
12	4739213	1	225S	BRACKET	STAFFA
13	4779685	1	193T	TUBE	TUBO RIGIDO
14	11193871	18	132R	LOCKWASHER 8,4x16	ROSETTA DI SICUREZZA 8,4x16
17	16043221	4	40V	SCREW 8x1,25x16	VITE 8x1,25x16
18	16043421	6	40V	SCREW 8x1,25x20	VITE 8x1,25x20
19	16043631	2	40V	SCREW 8x1,25x25	VITE 8x1,25x25
20	16044321	4	40V	SCREW 8x1,25x55	VITE 8x1,25x55
21	14048217	6	10V	NUT 8x1,25x8,8	DADO 8x1,25x8,8
22	79050381	1	193T	TUBE	TUBO RIGIDO
23	79050442	1	91A	DIPSTICK	ASTA LIVELLO
24	599777		123G	SEAL ASSY	GUARNIZIONE TENUTA FRONTALE

D 1572 Tel. n. 250905 →

ENGINE LUBRICATION -- LUBRIFICAZIONE MOTORE -- GRAISSAGE DU MOTEUR -- MOTORSCHMIERUNG --
ENGRASE DEL MOTOR

A3.01

1A

N.T.R. 200 - 15.10.1990

604.01.001.05

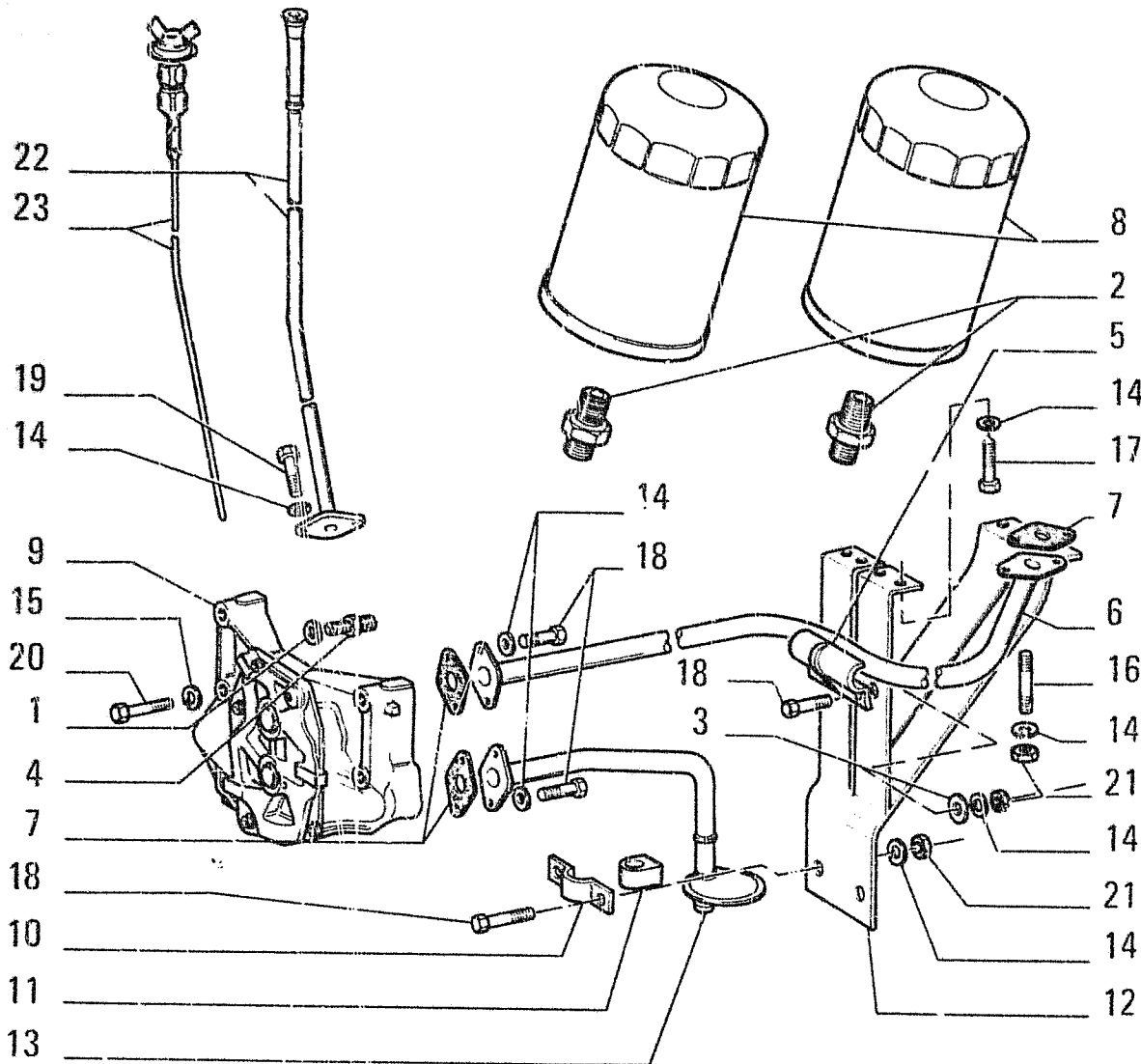

C 1572 → Tel.n. 250904

ITEM	PART NUMBER	QTY	TRANS CODE	DESCRIPTION	DESCRIZIONE
1	561293	1	150G	O-RING	GUARNIZIONE O-R
2	4262887	2	20R	FITTING	RACCORDO
3	4598124	2	131R	WASHER	ROSETTA
4	4607670	1	90B	FILLER PLUG	BOCCHETTONE INTRODUZIONE
5	4614111	1	110C	COLLAR	COLLARE
6	4617481	1	133T	TUBE	TUBO RIGIDO
7	4617482	3	123G	SEAL ASSY	GUARNIZIONE TENUTA FRONTALE
8	4630787	2	20E	FILTERING ELEMENT	ELEMENTO FILTRANTE
9	4699371	1	153P	OIL PUMP - ASSEMBLY SEE SGR. A3.02	POMPA OLIO - COMPLETO VEDERE SGR. A3.02
10	4719705	1	231S	CLIP	STAFFETTA
11	4719706	1	30M	SLEEVE	MANICOTTO
12	4731816	1	225S	BRACKET	STAFFA
13	4731819	1	193T	TUBE	TUBO RIGIDO
14	11193871	16	132P	LOCKWASHER 8,4x16	ROSETTA DI SICUREZZA 8,4x16
15	11198071	4	132R	LOCKWASHER 8,2x15	ROSETTA DI SICUREZZA 8,2x15
16	13516821	2	210P	STUD 8x1,25x32	PRIGIONIERO 8x1,25x32
17	16043221	4	40V	SCREW 8x1,25x16	VITE 8x1,25x16
18	16043421	7	40V	SCREW 8x1,25x20	VITE 8x1,25x20
19	16043631	2	40V	SCREW 8x1,25x25	VITE 8x1,25x25
20	16044321	4	40V	SCREW 8x1,25x55	VITE 8x1,25x55
21	16100811	6	10D	NUT 8x1,25x6,5	DADO 8x1,25x6,5
22	79037665	1	193T	TUBE C1611	TUBO RIGIDO C1611
	79050381	1	193T	TUBE D1611	TUBO RIGIDO D1611
23	79037668	1	91A	DIPSTICK C1611	ASTA LIVELLO C1611
	79050442	1	91A	DIPSTICK D1611	ASTA LIVELLO D1611

ENGINE LUBRICATION - LUBRIFICAZIONE MOTORE - GRAISSAGE DU MOTEUR - MOTORSCHMIERUNG - ENGRASE DEL MOTOR

A3.01

1

N.T.R. 158 - 13.03.1987

604.01.081.03

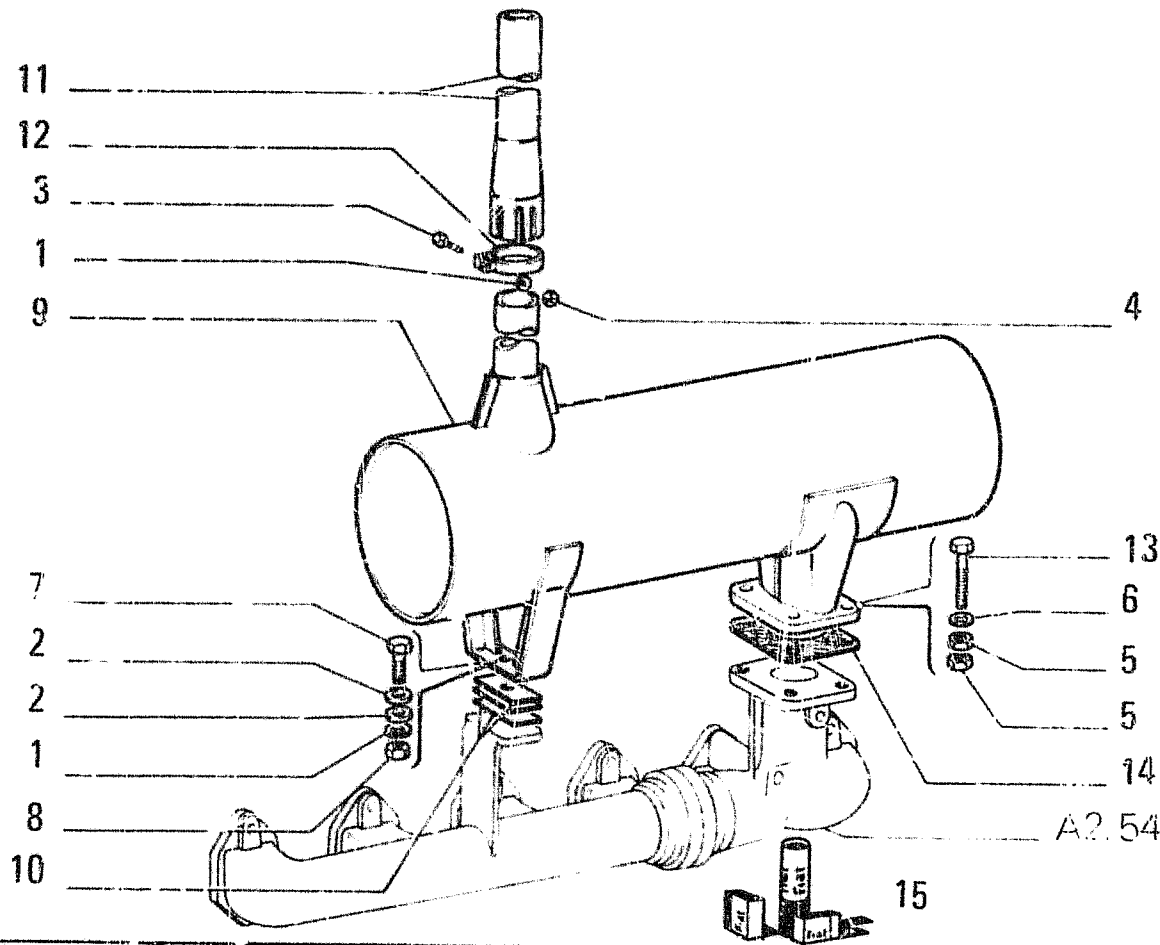

ITEM	PART NUMBER	QTY	TRANS CODE	DESCRIPTION	DESCRIZIONE
1	10517071	2	132R	LOCKWASHER 12,2x3,1	ROSETTA DI SICUREZZA 12,2x3,1
2	10520001	2	131R	WASHER 12,2x22	ROSETTA 12,2x22
3	11112431	1	40V	SCREW 12x1,75x30	VITE 12x1,75x30
4	11702921	1	10D	NUT 12x1,75x10	DAVVO 12x1,75x10
5	12164721	8	10D	NUT 10x1,25x8	DAVVO 10x1,25x8
6	12638601	4	131R	WASHER 10,2x18	RIVSETTA 10,2x18
7	15540631	1	40V	SCREW 12x1,25x40	VITE 12x1,25x40
8	16101521	1	10D	NUT 12x1,25x10	DAVVO 12x1,25x10
9	79014524	1	160S	MUFFLER	SILENZIATORE
10	79014536		198S	SHIM	SPESSORE
11	79025853	1	193T	TUBE	TUBO RIGIDO
12	79026197	1	180C	COLLAR	COLLARE
13	79030132	4	40V	SCREW	VITE
14	79032209	1	123G	SEAL ASSY	GUARNIZIONE TENUTA FRONTALE
15	79055596	1	1K	KIT SEE PAGE 9 C1572	KIT VED PAG 9 C1572
	79086428	1	1K	KIT SEE PAGE 9 D1572	KIT VED PAG 9 D1572

EXHAUST PIPE - TUBAZIONE DI SCARICO - CANALISATION D'ECHAPPEMENT - AUSPUFFROHR -
TUBERÍA DE ESCAPE

A2.56

N.T.R. 191 - 20.02.1990

604.01.081.04

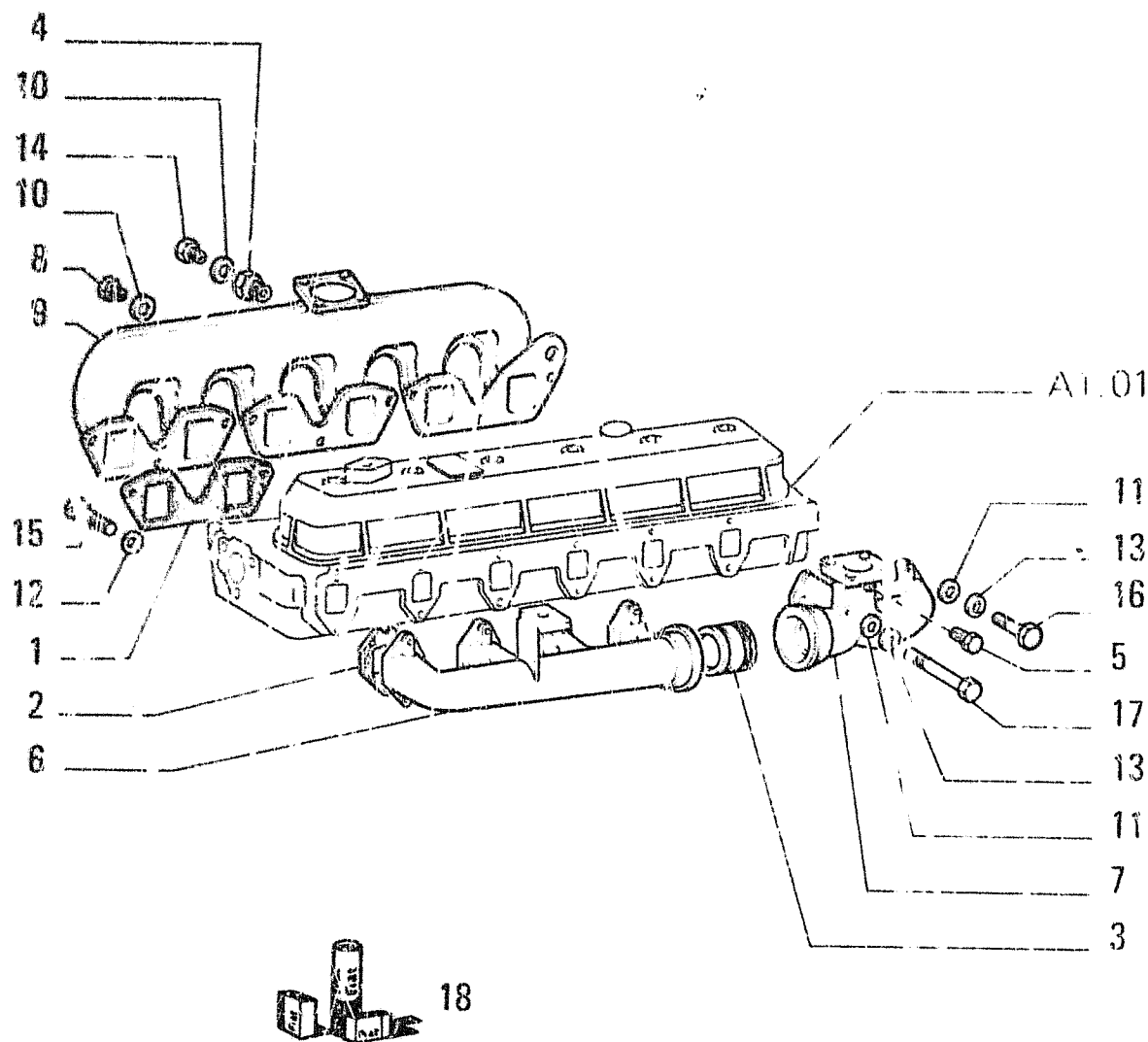

ITEM	PART NUMBER	QTY	TRANS CODE	DESCRIPTION	DESCRIZIONE
15	16043621	9	40V SCREW 8x1.25x25	D1572	VITE 8x1.25x25 D1572
16	4799275	3	40V SCREW	D1572	VITE D1572
	4800842	8	40V SCREW	D1572	VITE D1572
	16043821	11	40V SCREW 8x1.25x30	C1572	VITE 8x1.25x30 C1572
17	4800844	1	40V SCREW	D1572	VITE D1572
	16045021	1	40V SCREW 9x1.25x90	C1572	VITE 9x1.25x90 C1572
18	79055596	1	1K KIT SEE PAGE 9	C1572	KIT VED. PAG.9 C1572
	79036428	1	1K KIT SEE PAGE 9	D1572	KIT VED. PAG.9 D1572

INTAKE AND EXHAUST MANIFOLDS - CONDOTTI ASPIRAZIONE E SCARICO - TUBULURES D'ADMISSION ET D'ECHAPPEMENT - SAUGROHR UND AUSPUFFKUEHMEN - COLECTORES DE ADMISION Y ESCAPE

1
A2.54
N.T.R. 191 - 20.02.1990
604.01.081.04

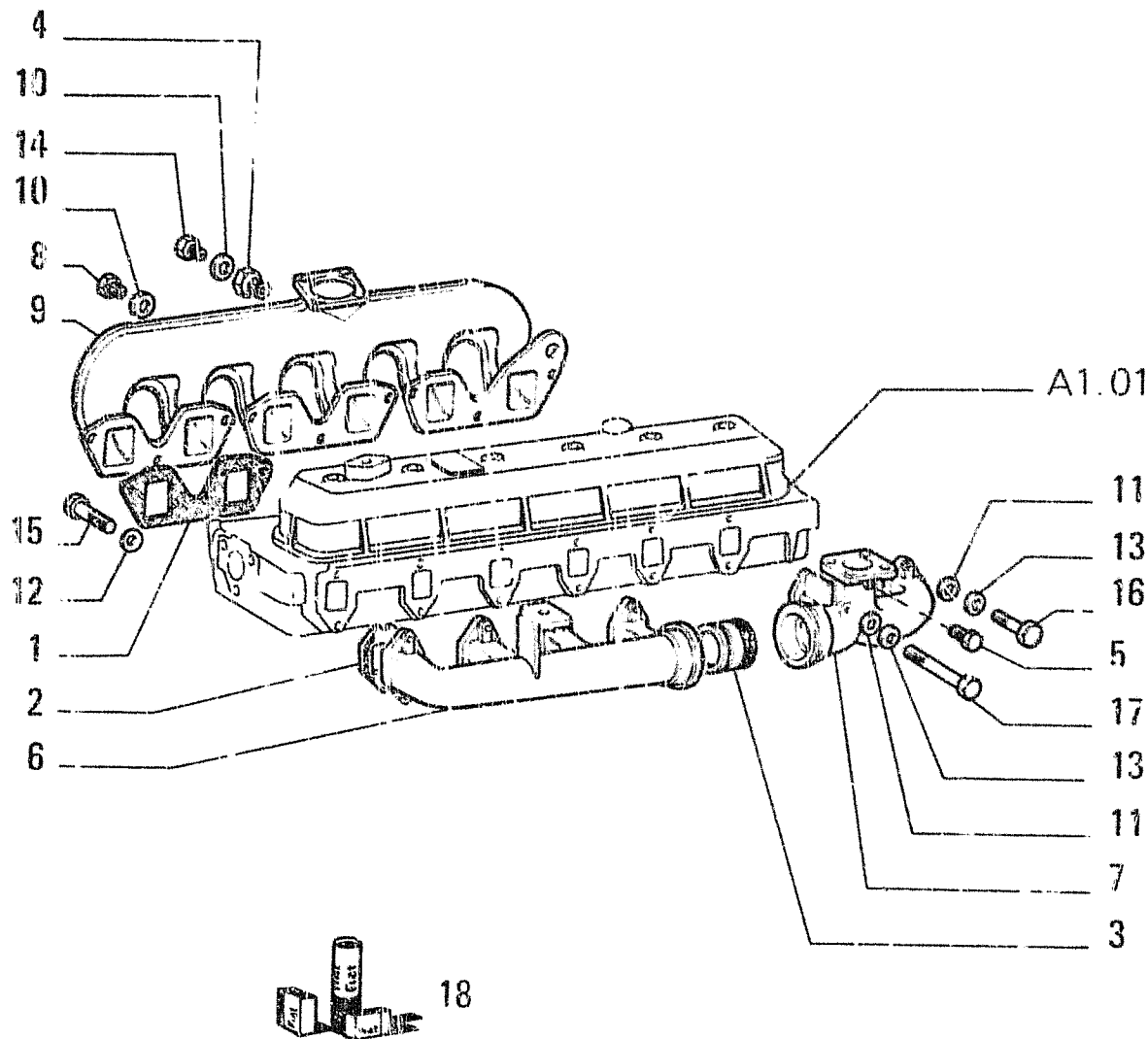

I T E M	PART NUMBER	Q T Y	TRANS CODE	DESCRIPTION	DESCRIZIONE
	4601827	3	123G	SEAL ASSY C1572	GUARNIZIONE TENUTA FRONTALE C1572
	4776544	3	123G	SEAL ASSY D1572	GUARNIZIONE TENUTA FRONTALE D1572
2	4601981	6	123G	SEAL ASSY C1572	GUARNIZIONE TENUTA FRONTALE C1572
	4813566	6	123G	SEAL ASSY D1572	GUARNIZIONE TENUTA FRONTALE D1572
3	4602270	1	45A	RING	ANELLO
4	4663081	1	20R	FITTING	RACCORDO
5	4723150	1	50T	PLUG C1572	TAPPO C1572
	4817522	1	50T	PLUG D1572	TAPPO D1572
6	4730554	1	188C	MANIFOLD - FRONT	COLLETTORE - ANTERIORE
7	4730555	1	188C	MANIFOLD - REAR	COLLETTORE - POSTERIORE
8	4753563	1	50T	PLUG	TAPPO
9	4754492	1	188C	MANIFOLD C1572	COLLETTORE C1572
	4786900	1	188C	MANIFOLD D1572	COLLETTORE D1572
10	10260160	2	133R	SEAL 10,2x14	ROSETTA DI TENUTA 10,2x14
11	10519601	12	131R	WASHER 8,15x17	ROSETTA 8,15x17
12	10519601	9	131R	WASHER 8,15x17 D1572	ROSETTA 8,15x17 D1572
	11193871	9	132R	LOCKWASHER 8,4x16 C1572	ROSETTA DI SICUREZZA 8,4x16 C1572
13	4800841	12	131R	WASHER D1572	ROSETTA D1572
	11198071	12	132R	LOCKWASHER 8,2x15 C1572	ROSETTA DI SICUREZZA 8,2x15 C1572
14	11903011	1	50T	PLUG 10x1x7	TAPPO 10x1x7
15	16043421	9	40V	SCREW 8x1,25x20 C1572	VITE 8x1,25x20 C1572

INTAKE AND EXHAUST MANIFOLDS - CONDOTTI ASPIRAZIONE E SCARICO -- TUBULURES D'ADMISSION
ET D'ECHAPPEMENT - SAUGROHR UND AUSPUFFKRUEMMER - COLECTORES DE ADMISION Y ESCAPE

1

A2.54

N.T.R. 191 - 20.02.1990

604.01.081.04

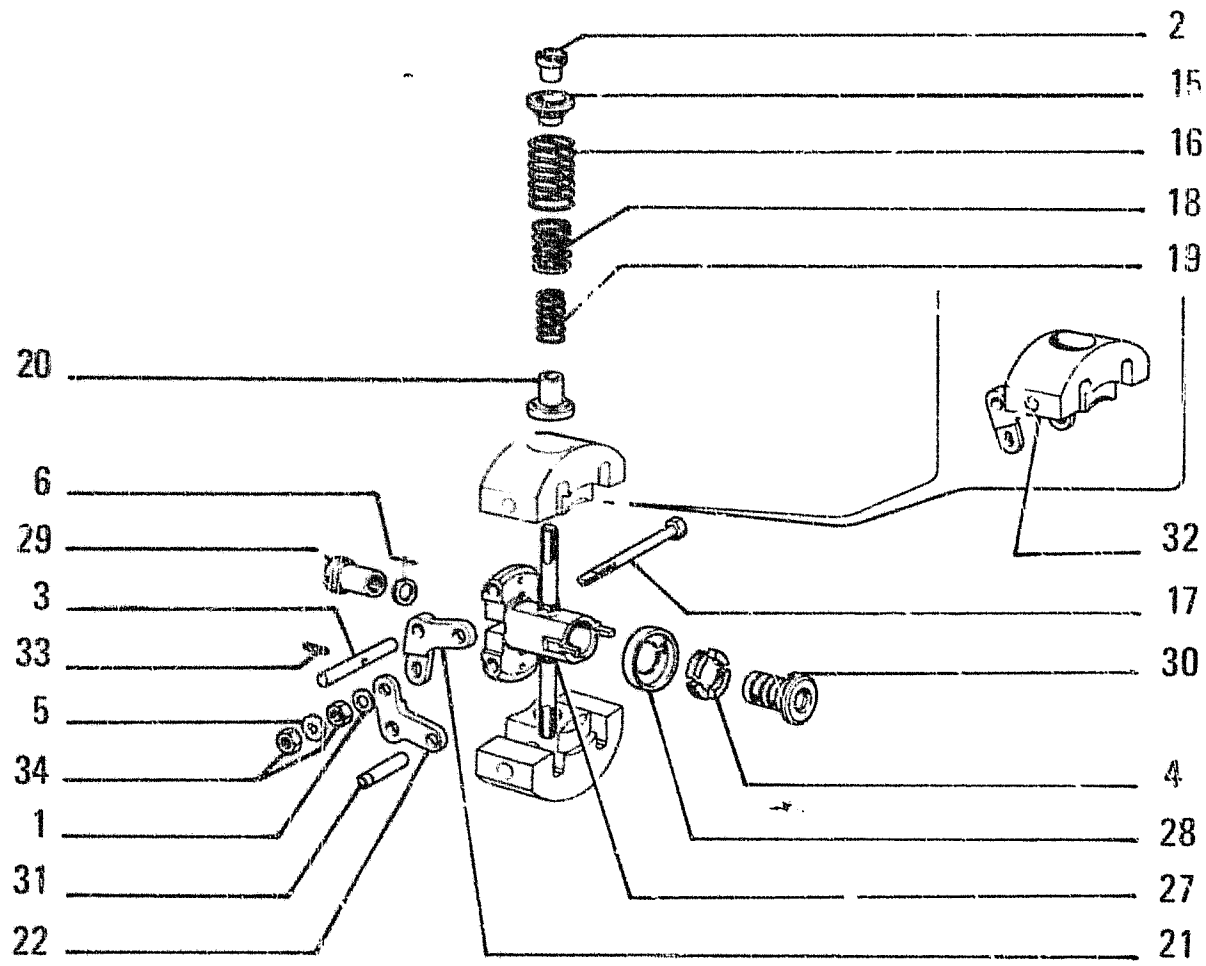

ITEM	PART NUMBER	QTY	TRANS CODE	DESCRIPTION	DESCRIZIONE
28	766299	1	60S	CUP	SCODFLINO
29	766300	1	50G	RING NUT	GHIERA
30	766642	1	67G	COUPLING	GIUNTO
31	766645	4	80P	PIN	PERNO
32	768069	2	67M	FLYWEIGHT	MASSA CENTRIFUGA
33	14159670	2	200S	PIN 2,8x14	SPINA 2,8x14
34	15896211	2	10D	NUT 6x1x5	DADO 6x1x5

C 1572 → Tel.n. 250904

766662

GOVERNOR REGULATING ASSY - DISPOSITIVO DI REGOLAZIONE - DISPOSITIF DE REGLAGE -
 REGELVORRICHTUNG - DISPOSITIVO DE REGULACIÓN

A2.37

N.T.R. 158 - 15.03.1987

604.01.081.03

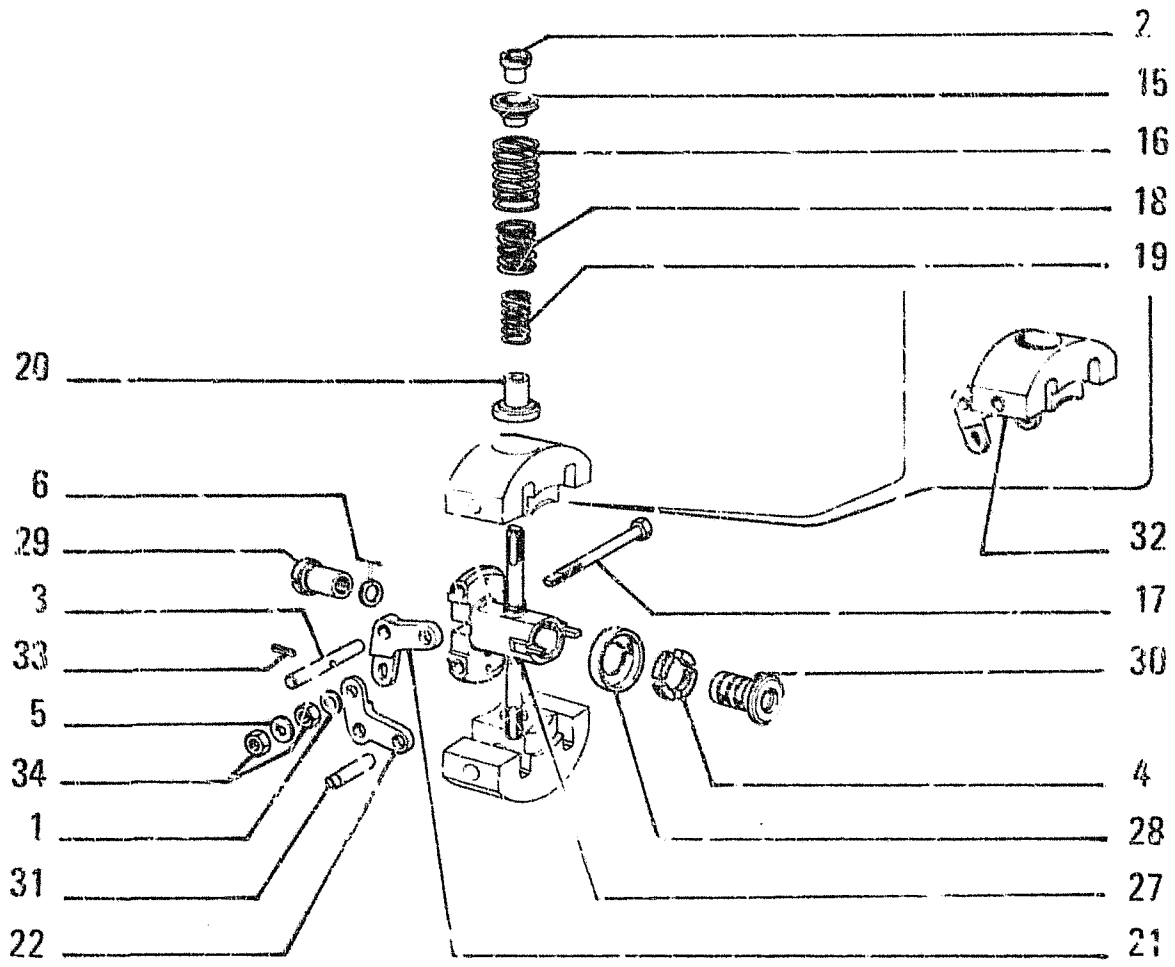

C 1572 → Tel.n. 250904

ITEM	PART NUMBER	QTY	TRANS CODE	DESCRIPTION	DESCRIZIONE
1	705726	1	131R	WASHER	ROSETTA
2	706210	2	50G	RING NUT	GHIERA
3	722353	2	80P	PIN	PERNO
4	723857	4	60T	BLOCK	TASSELLO
5	752758	1	131R	WASHER	ROSETTA
6	758880	1	131R	WASHER - THICKNESS 2,00	ROSETTA - SPESSORE 2,00
	758881	1	131R	WASHER - THICKNESS 1,90	ROSETTA - SPESSORE 1,90
	758882	1	131R	WASHER - THICKNESS 1,80	ROSETTA - SPESSORE 1,80
	758883	1	131R	WASHER - THICKNESS 1,70	ROSETTA - SPESSORE 1,70
	758884	1	131R	WASHER - THICKNESS 1,75	ROSETTA - SPESSORE 1,75
	758885	1	131R	WASHER - THICKNESS 1,85	ROSETTA - SPESSORE 1,85
	758886	1	131R	WASHER - THICKNESS 1,95	ROSETTA - SPESSORE 1,95
	758887	1	131R	WASHER - THICKNESS 1,60	ROSETTA - SPESSORE 1,60
	758888	1	131R	WASHER - THICKNESS 1,65	ROSETTA - SPESSORE 1,65
	766093	1	131R	WASHER - THICKNESS 1,40	ROSETTA - SPESSORE 1,40
	766094	1	131R	WASHER - THICKNESS 1,45	ROSETTA - SPESSORE 1,45
	766095	1	131R	WASHER - THICKNESS 1,50	ROSETTA - SPESSORE 1,50
	766096	1	131R	WASHER - THICKNESS 1,55	ROSETTA - SPESSORE 1,55
15	759073	2	95B	BUSHING	BOCCOLA
16	759074	2	100M	SPRING	MOLLA
17	760157	1	80P	PIN	PERNO
18	763638	2	100M	SPRING	MOLLA
19	763714	2	100M	SPRING	MOLLA
20	763754	2	120P	PLATE	PIATTELLO
21	765290	2	45L	LEVER	LEVA
22	765291	2	45L	LEVER	LEVA
27	766298	1	320C	SPIDER	CROCIERA

766662

GOVERNOR REGULATING ASSY - DISPOSITIVO DI REGOLAZIONE - DISPOSITIF DE REGLAGE -
 REGELVORRICHTUNG - DISPOSITIVO DE REGULACIÓN

A2.37

N.T.R. 158 - 13.03.1987
 604.01.081.03

DESIGNAZIONE BASE	BASIC DESIGNATION	DESIGNATIONS-BASES	GRUNDZEICHNUNGEN	DENOMINACIONES BASE
319C	CRISTALLO ATERMICO	ATHERMIC GLASS PANE	GLACE ATHERMIQUE	CRISTAL ATERMICO
326A	TRASMISSIONE POSTERIORE	REAR TRANSMISSION	TRANSMISSION ARRIERE	
320C	CROCIERA	SPIDER	CROISILLON	CRUCETA
3201	PNEUMATICI 14.00X24	TIRES 14.00X24	PNEUS 14.00X24	
3208	PNEUMATICI 15.5X25	TIRES 15.5X25	PNEUS 15.5X25	
3209	PNEUMATICI 17.5X25	TIRES 17.5X25	PNEUS 17.5X25	
321C	CRONOGIOMETRO	TACHOMETER	TACHYMETRE	CUENTAREVOLUCIONES
3210	PNEUMATICI 22X25	TIRES 22X25	PNEUS 22X25	
3211	PNEUMATICI 20.5X25	TIRES 20.5X25	PNEUS 20.5X25	
3213	PNEUMATICI 26.5X25	TIRES 26.5X25	PNEUS 26.5X25	
3219	PNEUMATICI 29.5X25	TIRES 29.5X25	PNEUS 29.5X25	
322C	CRONOTACHIMETRO	SPEEDOMETER	CHRONOTACHYMETRE	CRONOTACOMETRO
325C	CRUSCOTTO	DASHBOARD	PLANCHE DE BORD	TABLERO
330C	CUFFIA RADIATORE	RADIATOR GUARD	CAPOT	CAPUCHON
331C	CUFFIA DI GOMMA	RUBBER BOOT	CAPUCHON CAOUT- CHOUC	CAPUCHON DE CAUCIHO
331C				
332C	CUFFIA PER PROIETTORE	HEADLAMP BOOT	CALOTTE DE PRO- JECTEUR	SOPORTE DEL PROYECTOR
332C				
333C	CUNEO	WEDGE	COIN	CUNA
334C	CUFFIA PARAPOLVERE	DUST BOOT	CAPUCHON POUR POUSSIER	CAPUCHON GUARDAPOLVO
3402	RUOTE CON CERCHIO 14.00-25	WHEELS W/RIM 14.00-25		
3403	RUOTE CON CERCHIO 8.00TG-24	WHEELS W/RIM 8.00TG-24		
341C	CUSCINETTO	BEARING	ROULEMENT	RODAMIENTO
345C	CUSCINO	CUSHION	COUSSIN	ALMOHADA
346C	CUSTODIA PER LIBRETTI	PORTFOLIO	POCHETTE A PAPIERS	FUNDA PARA MAPAS
3665	BLOCCAGGIO IDRAULICO	HYDRAULIC LOCK	BLOCAGE HYDRAULIQUE	ANCLAJE HIDRAULICO
3763	COMANDO FRENI SERVIZIO	BRAKE PEDALS		
3764	COMANDO FRENI STAZIONAMENTO	PARKING BRAKE	FREINS DE STATIONNEMENT	
3962	COMANDO FRIZIONI DI STERZO	STEERING CONTROL		
3966	TUBAZIONI EST FRIZIONI STERZO	STEERING OUTER PIPING		
3967	TUBAZIONI COLLEG.FRIZ.STERZO	STEERING CONNECTING PIPING		
390C	CORNICE DELLA TARGA	NUMBER PLATE FRAME	MONTURE DE PLAQUE	MARCO DE MATRICULA
390C				
391C	CORNICE DEL PROIETTORE	HEADLAMP RIM	MONTURE DE PRO- JECTEUR	MARCO DE PROYECTOR
391C				
392C	CORNICE DI GOMMA	WEATHERSEAL STRIP	CONTOUR CAOUTCHOUC	BORILETE DE GOMA
393C	CABINA SICUREZZA	ROPS CAB	CABINE DE SECURITE	CABINA DE SEGURIDAD
394C	CASSETTO DISTRIBUTORE	CONTROL VALVE SPOOL	BOITE DISTRIBUTEUR	CORREDERA DEL DISTRIBUIDOR
395C	COLORE	COLOR	COULEUR	COLOR
396C	CORPO TRATTORE	TRACTOR BODY	CORPS TRACTEUR	CUERPO TRACTOR

DESIGNAZIONE BASE	BASIC DESIGNATION	DESIGNATIONS-BASES	GRUNDZEICHNUNGEN	DENOMINACIONES BASE
397C	CORPO CARRELLO	TRACK FRAME	LAUFWERKSRAHMEN	CARRO DE ORUGA
398C	CRISTALLO COLORATO	TINTED ATHERMIC GLASS PANE	SCHEIBE,GETOENT	CRISTAL COLOREADO
399C	CONVERTITTORE PNEUMOIDRAULICO	POVER CLUSTER	HYDROPNEUMATISCHE SERVO/BREMSE	SERVOFRENO NEUMOHIDRAULICO
400C	COMBUSTIBILE	FUEL	KRAFTSTOFF	COMBUSTIBLE
401C	COSTAMPATO	MOLD-ON CONNECTOR		
401S	SARACINESCA	GATE VALVE	VANNE	COMPUERTA
402S	SCATOLA CAMBIO	TRANSMISSION HOUSING	BOITE DE VITESSES	CAJA DE CAMBIO
403S	SCATOLA RIDUTTORE FINALE	FINAL DRIVE HOUSING	CARTER DE REDUCTEUR FINAL	CAJA DE REDUCTOR
404S	SCATOLA TRASMISSIONE	REAR HOUSING	CARTER PONT ARRIERE	CAJA DE TRANSMISION
405S	SIGILLANTE	SEALANT	PRODUIT D'ETANCHEITE	SELLADOR
406S	SPRUZZATORE	NOZZLE	GICLEUR	INYECTOR
407S	STRISCIA ANTISDRUCCIOLIO	ANTI-SKID	BANDE ANTIDERAPANTE	TIRA CONTRA-DESLIZAMIENTO
408S	STRUTTURA PROTEZIONE	RIPS CANOPY	STRUCTURE DE PROTECTION	ESTRUCTURA DE PROTECCION
409S	SEGMENTO FRENO	BRAKE LINING	SEGMENT DE FREIN	ZAPATA DE FRENO
410S	SERBATOIO OLIO IMP. IDRAULICO	HYDRAULIC TANK	RESERVOIR HYDRAULIQUE	DEPOSITO ACEITE SISTEMA HIDR.
411S	SERBATOIO COMBUSTIBILE E OLIO	FUEL AND OIL TANK	RESERVOIR COMBUSTIBLE/HUILE	TANQUE COMBUSTIBLE Y ACEITE
412S	SEMIMAGLIA CINGOLO	HALF TRACK LINK	DEMI-MAILLON	SEMIMALLA DE ORUGA
413S	SEMIFRANIERA	HALF MINGE	DEMI-CHARNIERE	SEMIBISAGRA
414S	SCHEMA	SCHEMATIC	SCHEME	ESQUEMA
415S	SEMIFASCIA	HALF BAND	DEMI-BANDE	SEMIFAJA
416S	SGRINATORE	DEFROSTER	DESIVREUR	DESCONGELADOR
417S	SEMIFLANGIA	HALF FLANGE	DEMI-BRIDE	SEMIBRIDA
418S	SERIE	SET	JEU	JUEGO
419S	SGANCIO SOLLEVAMENTO	LIFT RELEASE VALVE		
420S	SERBATOIO ARIA	AIR RESERVOIR	RESERVOIR A AIR	DEPOSITO DE AIRE
421S	SOLVENTE	SOLVENT	SOLVANT	
429P	PER VARIANTE	FOR SPECIAL EQUIPMENT	POUR VARIANTE	PARA VARIANTE
489A	REDUTTORE LATERALE	FINAL DRIVE	REDUCTEUR LATERAL	
490P	PERNO A SFERA	BALL PIN	AXE SPHERIQUE	ROTULA
491P	POZZETTO	WELL	ETUI	DEPOSITO
492P	PUNTA DENTE BENNA	BUCKET TOOTH POINT	POINTE DENT DE GODET	PUA DE DIENTE CUCHARA
493P	PIATTAFORMA	PLATFORM	PLATE-FORME	PLATAFORMA
50G1	RUOTE CARRELLO CINGOLO	TRACK ROLLERS	ROUF PORTEUR DE CHENILLE	RUEDA DE APOYO DE LA ORUGA
50G2	TENDICINGOLO	TRACK IDLER	TENDEUR DE CHENILLE	
50G3	RULLO SOSTEGNO CINGOLO	TRACK CARRIER ROLLER	GALET DE RETOUR DE CHENILLE	RUEDA DE SOPORTE DE LA ORUGA
50G4	RIPARI CINGOLO	TRACK COVERS	PROTECTIONS DE CHENILLE	BLINDAJE DE CADENAS
56G1	SOSPENSIONE ANT CINGOLO	TRACK FRONT SUSPENSION	SUSPENSION AV. CHENILLE	
56G3	COLLEGAMENTO CARRELLI	TRACK GUIDING PLATES		
56G5	SOSPENSIONE POST CINGOLO	REAR SUSPENSION	SUSPENSION AR. CHENILLE	
600J	VARIANTE A RICHIESTA	SPECIAL EQUIPMENT	EQUIPEMENT SPECIAL	EQUIPO SPECIALE

DESIGNAZIONE BASE	BASIC DESIGNATION	DESIGNATIONS-BASES	GRUNDBEZEICHNUNGEN	DENOMINACIONES BASE
600U	PROVEDERE IN LOCO	OBTAIN LOCALLY	A PROCURER SER	CONSEGUIR LOCALMENTE
600W	TAGLIARE DI MISURA	CUT AT ASSEMBLY	COUPER SELON BESOIN	CORTAR SEGUN NECESARIO
600X	FINO AL TELAIO...	UP TO SERIAL NO...	JUSQUAU CHASSIS	HASTA EL ARMAZON...
600Y	DAL TELAIO...	FROM THE SERIAL NO...	A PARTIR DU CHASSIS	A PARTIR DEL ARMAZON...
601E	VEDERE NOTA	SEE NOTE	VOIR REMARQUE	VEASE NOTA
63G0	COMANDI DIREZIONALI	STEERING SYSTEM	COMMANDE DE DIRECTION	MANDO DE LA DIRECTION
65G3	COMANDI FRENO	BRAKE CONTROLS	COMMANDE DE FREINS	MANDO DEL FRENO
7117	LEVERAGGI	CONTROL LEVERS	TRINGLERIES	TIMONIERA
7211	TELAIO INFERIORE	LOWER MAIN FRAME	CHASSIS INFERIOR	ARMAZON INFERIOR
7215	TELAIO SUPERIORE	UPPER MAIN FRAME	CHASSIS SUPERIOR	ARMAZON SUPERIOR
74G0	BATTERIE, SEDE E RIPARI	BATTERY, SEAT AND SUPPORT	BATTERIE, SIEGE ET PROTECTION	
7480	MOTORIDUTTORE TRASLAZIONE	DRIVE MOTOREDUCTION		
7482	MOTORIDUTTORE ROTAZIONE	SWING MOTOREDUCTION		
75GA	IMPIANTO ELETTRICO	ELECTRICAL SYSTEM	SYSTEME ELECTRIQUE	
75G0	COMANDI ELETTRICI	ELECTRIC CONTROLS	COMMANDES ELECTRIQUE	ELECTRISCHE STEUERUNG
75G1	APPARECCHI ELETTRICI	ELECTRICAL INSTRUMENTS	DISPOSITIFS ELECTRIQUES	ELEKTRISCHE ANZEIGENSTRUMENTE
75G3	CAVI AVVIAMENTO	STARTING CABLES	CABLES DEMARRAGE	STARTERKABEL
75G4	CAVI VARI	VARIOUS CABLES	CABLE DIVERSES	MEHRERE KABEL
75G5	APPARECCHI ILLUMINAZIONE	LIGHTS	ECLAIRAGE	BELEUCHTUNG
75G9	TERMOMETRI E MANOMETRI	TEMPERATURE-PRESSURE GAUGES	THERMOMETRES ET MANOMETRES	THERMOMETER UND MANOMETER
7874	BLOCCAGGIO TORRETTA	SUPERSTRUCTURE LOCKING	BLOCAGE SUPERSTRUCTURE	
8079	BENNA SCARICO BILATERALE	BILATERAL DISCHARGE BUCKET	GODET VIDAGE BILATERAL	SEITENKIPPSCHAUFEL
82GA	IMPIANTO IDRAULICO	HYDRAULIC SYSTEM	SYSTEME HYDRAULIQUE	SISTEMA DE ALUMBRADO
82GD	TUBAZIONI	PIPING		
82G1	FILTRI SERBATOIO OLIO	OIL TANK FILTERS		LEITUNGEN
82G3	POMPA ATTREZZO	EQUIPMENT PUMP	POMPE OUTIL	HYDR FILTER
82G4	DISTRIBUTORE ATTREZZO	EQUIPMENT CONTROL VALVE	DISTRIBUTEUR DE L'OUTIL	HYDRAULIKPUMPE
82G5	COMANDO DISTRIBUTORE ATTREZZO	CONTROL VALVE DRIVE	COMMANDE DE OUTIL	STEUERGERAET (ARBEITSHYDRAULIK)
82G6	TUBAZIONI IMPIANTO IDRAULICO	HYDRAULIC SYSTEM PIPING		HYDRAULIK-STEUERUNG
83G0	COFANI	HOODS	CAPOTS	LEITUNGEN FUER HYDRAULIKSYSTEM
83G6	RIPARI LATERALI COFANO	HOOD SIDE GUARDS	PROTECTIONS LATERALES CAPOT	MOTORHAUBEN
85G0	SEDILE CONDUTTORE	OPERATOR SEAT	SIEGE OPERATEUR	SEITENBLECHE
85G2	SOSTEGNO E RIPARI SEDILE	SEAT SUPPORT AND GUARD	SUPPORT ET PROTECTION SIEGE	FAHRERSITZ
8501	CATENARIA ANTIPOLVERE	SEALED TRACK CHAIN	CHENILLE SCLEE	SITZBEFESTIGUNG UND VERKLEIDUNG
8582	CABINA CORAZZATA	BULLETPROOF CAB	CABINE BLINDEE	KETTENZUG MIT STAUBDICHTUNG
87GA	POSTO GUIDA	OPERATORS COMPARTMENT		FAHRERHAUS GEPANZERT
87G0	PARAFANGHI-PEDANE	FENDERS-FLOORS	AILES - PLANCHERS	KOTFLUEGEL-TRITTBLECH
87G1	PROTEZIONI INFERIORI	BOTTOM GUARDS	PROTECTION INFERIEURS	PANZERWANNE
8877	STRUTTURA ROPS RIVESTITA			ROPS RAHMEN VERKLEIDET
9005	SOSTITUZIONE RAPIDA OLIO MOTORE	ENGINE OIL QUICK CHANGE		

A	ENGINE • MOTORE • MOTEUR • MOTOR • MOTOR
B	MECHANICAL TRANSMISSION • CLUTCH • TRANSMISSION • TRANSMISSION SHAFT • AXLES TRASMISSIONE MECCANICA • FRIZIONE • CAMBIO • ALBERO DI TRASMISSIONE • PONTI TRANSMISSION MECANIQUE • ENBRAYAGE • BOITE DE VITESSES • ARBRE DE TRANSMISSION • PONTS MECHANISCHE KRAFTÜBERTRAGUNG • KUPPLUNG • GETRIEBE • GELENKWELLE • AXISEN TRANSMISSION MECANICA • EMBRAGLE • CAMBIO • ARBOL DE TRANSMISSION • PUENTES

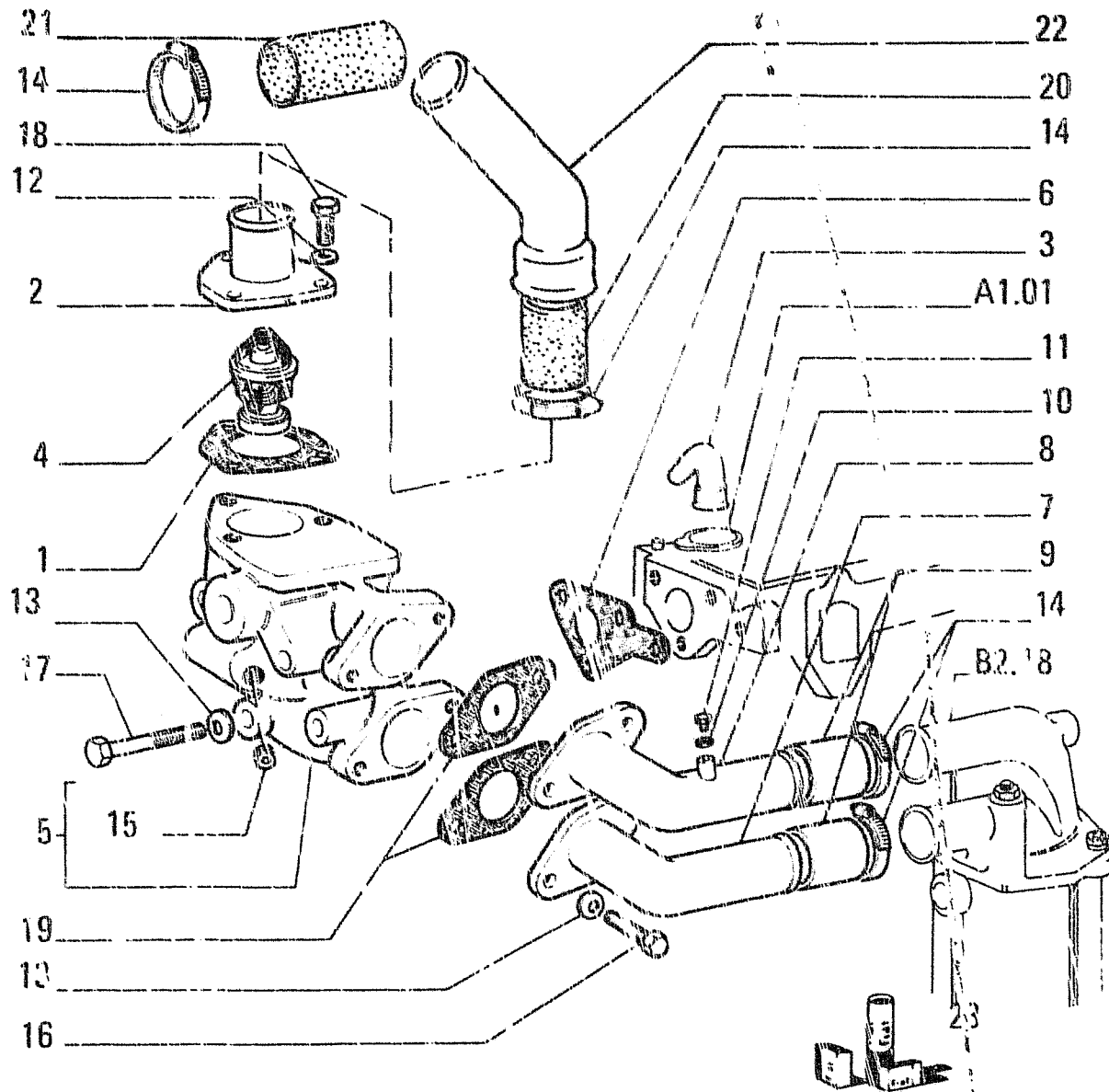

ITEM	PART NUMBER	QTY	TRANS CODE	DESCRIPTION	DESCRIZIONE
14	12174790	6	180C	COLLAR 47/67x14 C1572	COLLARE 47/67x14 C1572
	12182290	6	180C	COLLAR 50,5/56 D1572	COLLARE 50,5/56 D1572
		6	180C	COLLAR 50,5/56 C2906	COLLARE 50,5/56 C2906
	79083846	6	180C	COLLAR D2906	COLLARE D2906
15	14325211	1	50T	PLUG 20x1,5x13	TAPPO 20x1,5x13
16	15970721	4	40V	SCREW 10x1,25x25	VITE 10x1,25x25
17	15971621	4	40V	SCREW 10x1,25x90	VITE 10x1,25x90
18	16043621	3	40V	SCREW 8x1,25x25	VITE 8x1,25x25
19	4854715	2	122G	SEAL D3344	GUARNIZIONE D3344
	38824001	2	123G	SEAL ASSY C3344	GUARNIZIONE TENUTA FRONTALE C3344
20	76015587	1	30M	SLEEVE D2906	MANICOTTO D2906
	79028055	1	30M	SLEEVE C2906	MANICOTTO C2906
21	76015591	1	30M	SLEEVE D2906	MANICOTTO D2906
	79028056	1	30M	SLEEVE C2906	MANICOTTO C2906
22	79028058	1	193T	TUBE	TUBO RIGIDO
23	79055596	1	1K	KIT SEE PAGE 9 C1572	KIT VED. PAG.9 C1572
	79086428	1	1K	KIT SEE PAGE 9 D1572	KIT VED. PAG.9 D1572

WATER PUMP AND LINES - POMPA ACQUA E TUBAZIONI - POMPE ET CANALISATIONS D'EAU -
WASSERPUMPE UND LEITUNGEN- BOMBA DE AGUA Y TUBERIAS

A4.02

1

N.T.R. 200- 15. .J.1990

604.01.031.05

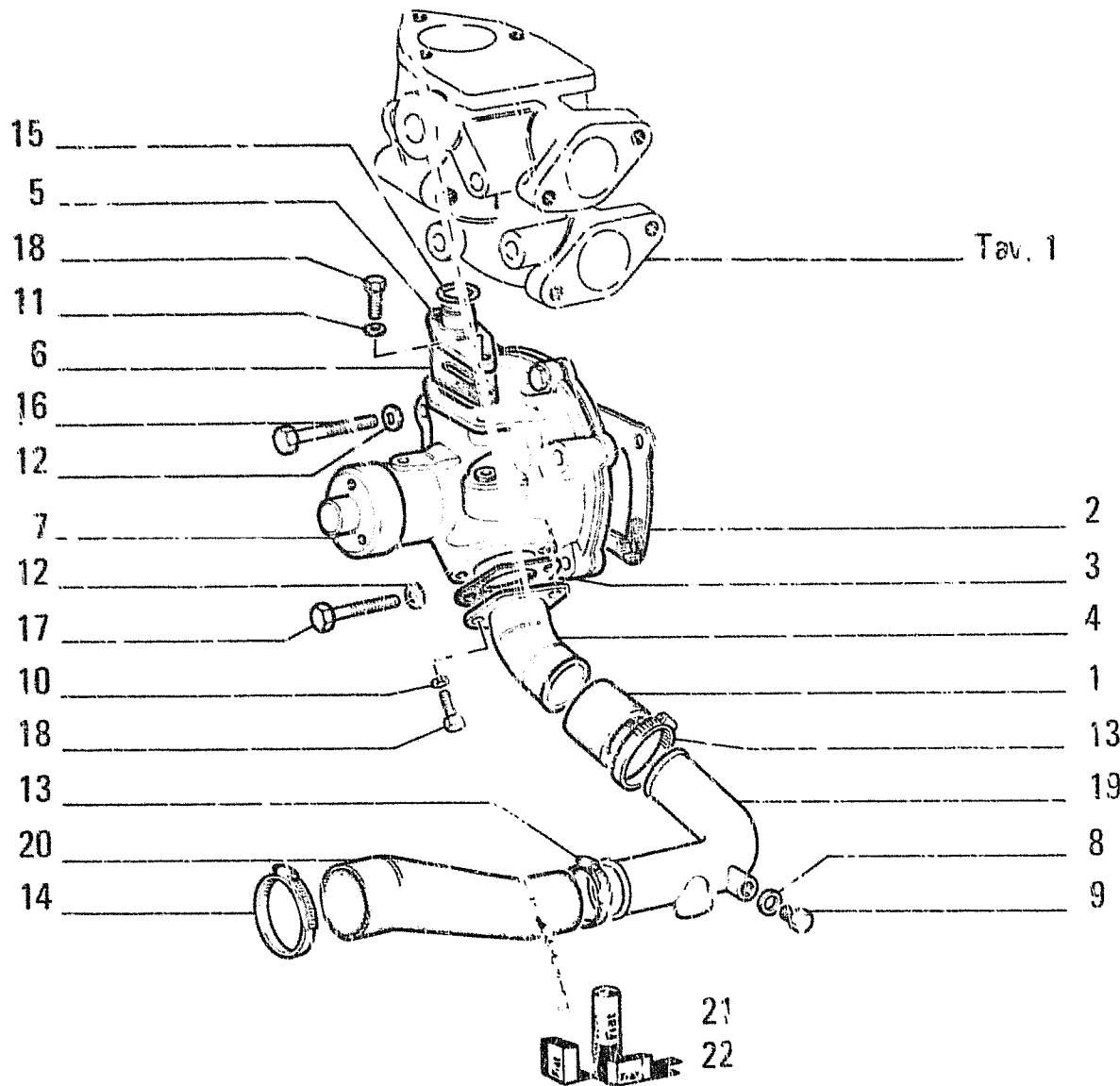

ITEM	PART NUMBER	QTY	TRANS CODE	DESCRIPTION	DESCRIZIONE
1	596152	1	30M	SLEEVE C2906	MANICOTTO C2906
	76014937	L	285T	HOSE 0,071M D2900	TUBO FLESSIBILE 0,071M D2900
2	4599561	1	123G	SEAL ASSY C3342	GUARNIZIONE TENUTA FRONTALE C3342
	4858073	1	122G	SEAL D3342	GUARNIZIONE D3342
3	4599562	1	123G	SEAL ASSY	GUARNIZIONE TENUTA FRONTALE
4	4615459	1	193T	TUBE - UPPER C1572	TUBO RIGIDO - SUPERIORE C1572
	4697838	1	193T	TUBE D1572	TUBO RIGIDO D1572
		1	193T	TUBE C2958	TUBO RIGIDO C2958
	4800147	1	193T	TUBE D2958	TUBO RIGIDO D2958
5	4673807	1	193T	TUBE C1572	TUBO RIGIDO C1572
	4774405	1	193T	TUBE D1572	TUBO RIGIDO D1572
		1	193T	TUBE C3350	TUBO RIGIDO C3350
6	4673810	1	123G	SEAL ASSY C1572	GUARNIZIONE TENUTA FRONTALE C1572
	4770435	1	123G	SEAL ASSY D1572	GUARNIZIONE TENUTA FRONTALE D1572
		1	122G	SEAL C3348	GUARNIZIONE C3348
	4848840	1	122G	SEAL D3348	GUARNIZIONE D3348
		1	122G	SEAL C3350	GUARNIZIONE C3350
7	4679242	1	152P	WATER PUMP - ASSEMBLY SEE SGR. A4.03 C1572	POMPA ACQUA - COMPLETO VEDI RE SGR. A4.03 C1572
	4784454	1	152P	WATER PUMP - ASSEMBLY SEE SGR. A4.03 D1572	POMPA ACQUA - COMPLETO VEDI RE SGR. A4.03 D1572
		1	152P	WATER PUMP - ASSEMBLY SEE	POMPA ACQUA - COMPLETO VEDI RE

WATER PUMP AND LINES -- POMPA ACQUA E TUBAZIONI -- POMPE ET CANALISATIONS D'EAU --
 WASSERPUMPE UND LEITUNGEN -- BOMBA DE AGUA Y TUBERIAS

A4.02

2

N.T.R. 200 - 15.10.1990

604.01.081.05

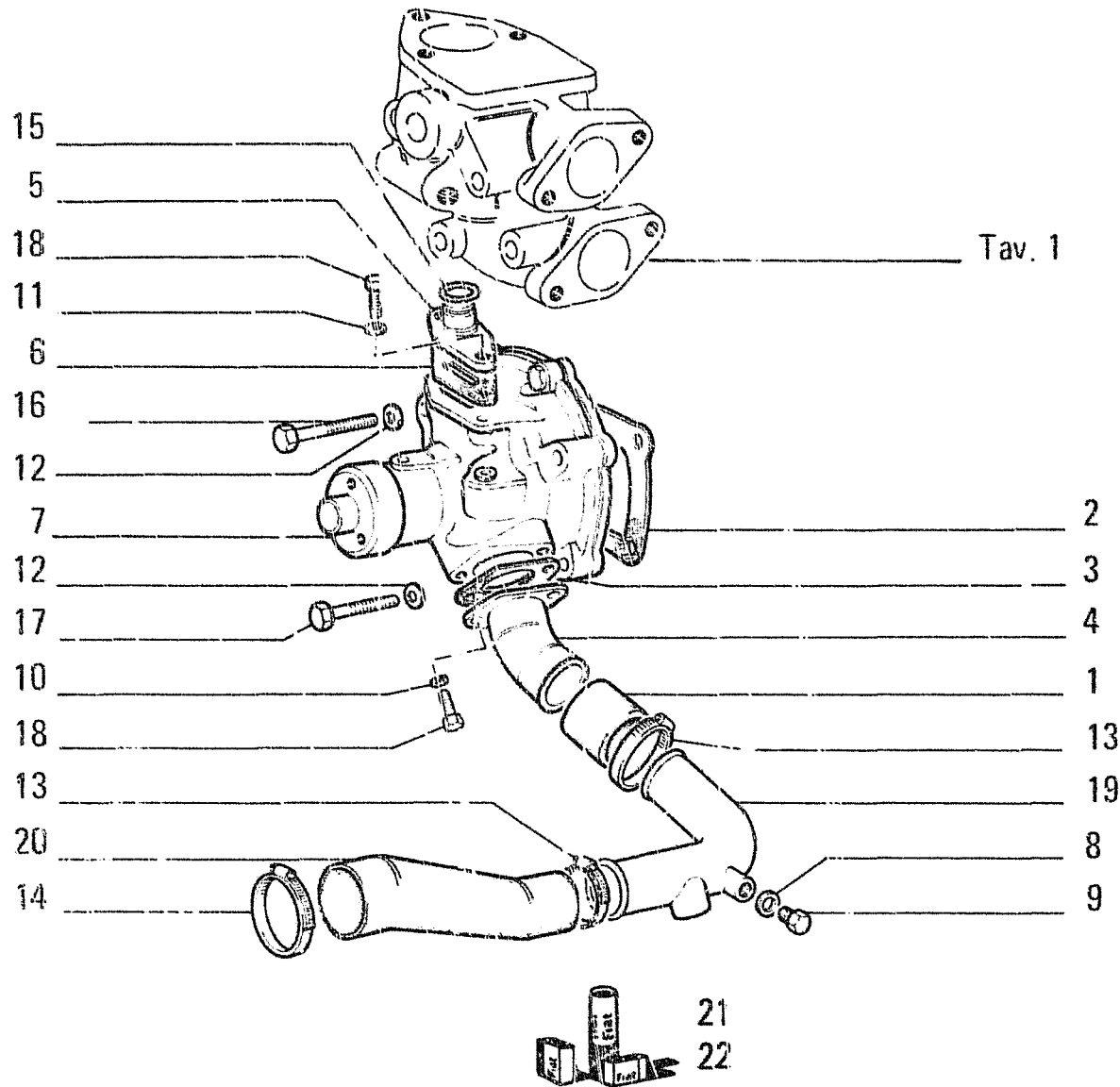

ITEM	PART NUMBER	QTY	TRANS CODE	DESCRIPTION	DESCRIZIONE
7	4784454 4813370	1	152P	SCR. A4.03 C3334 WATER PUMP - ASSEMBLY SEE SGR. A4.03/A D3334	SGR. A4.03 C3334 POMPA ACQUA - COMPLETO VEDERE SGR. A4.03/A D3334
8	10296685	1	133R	SEAL 16,2x22	ROSETTA DI TENUTA 16,2x22
9	10300711	1	50T	PLUG 16x1,5x9	TAPPO 16x1,5x9
10	10519621	2	131R	WASHER 8,45x17	ROSETTA 8,45x17
11	11193871	2	132R	LOCKWASHER 8,4x16 C3350	ROSETTA DI SICUREZZA 8,4x16 C3350
12	11190571 11198371	4 3	131R 132R	WASHER 10,5x20 D1572 LOCKWASHER 10,5x20 C1572	ROSETTA 10,5x20 D1572 ROSETTA DI SICUREZZA 10,5x20 C1572
13	12174090	3	180C	COLLAR 32/52x14 C2906	COLLARE 32/52x14 C2906
12	79083845	3	180C	COLLAR D2906	COLLARE D2906
14	12174790	1	180C	COLLAR 47/67x14 C2906	COLLARE 47/67x14 C2906
17	79083846	1	180C	COLLAR D2906	COLLARE D2906
10	14462881	1	158G	O-RING 3,53x18,64 C1572	GUARNIZIONE O-R 3,53x18,64 C1572
18	14463281	1	158G	O-RING 3,53x24,99 D1572	GUARNIZIONE O-R 3,53x24,99 D1572
13		1	158G	O-RING 3,53x24,99 C3350	GUARNIZIONE O-R 3,53x24,99 C3350
20	15888721	2	40V	SCREW 10x1,25x55	VITE 10x1,25x55
17	4605853	1	40V	SCREW D1572	VITE D1572
	15970921	1	40V	SCREW 10x1,25x35	VITE 10x1,25x35
18	16043421	4	40V	SCREW 8x1,25x20 C3350	VITE 8x1,25x20 C3350
19	79022242	1	193T	TUBE	TUBO RIGIDO
20	76015592	1	30M	SLEEVE D2906	MANICOTTO D2906

WATER PUMP AND LINES - POMPA ACQUA E TUBAZIONI - POMPE ET CANALISATIONS D'EAU -
WASSERPUMPE UND LEITUNGEN -- BOMBA DE AGUA Y TUBERIAS

A4.02

2

N.T.R. 200 - 15.10.1990

604.01.081.05

FIATALLIS FD7

A4.02 TAV. 2 PAG.3

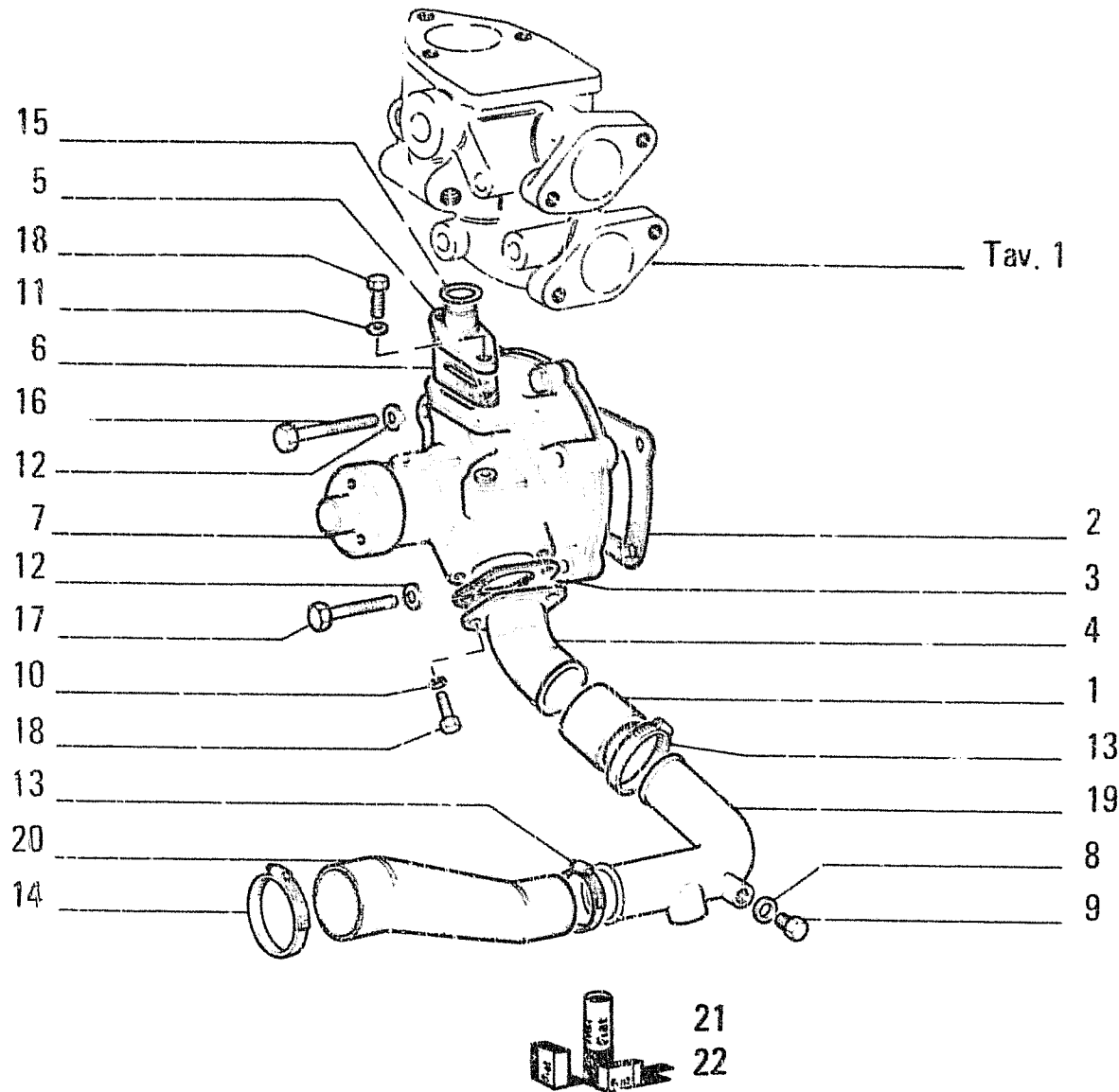

ITEM	PART NUMBER	QTY	TRANS CODE	DESCRIPTION	DESCRIZIONE
20	79028057	1	30M SLEEVE	C2906	MANICOTTO C2906
21	79055596	1	1K KIT SEE PAGE 9	C1572	KIT VED PAG 9 C1572
22	79046186	1	1K KIT SEE PAGE 9	C1572	KIT VED PAG 9 C1572
	79086428	1	1K KIT SEE PAGE 9	D1572	KIT VED PAG 9 D1572

WATER PUMP AND LINES - POMPA ACQUA E TUBAZIONI - POMPE ET CANALISATIONS D'EAU -
WASSERPUMPE UND LEITUNGEN - BOMBA DE AGUA Y TUBERIAS

A4.02

2

N.T.R. 200 - 15.10.1990

604.01.081.05

P5

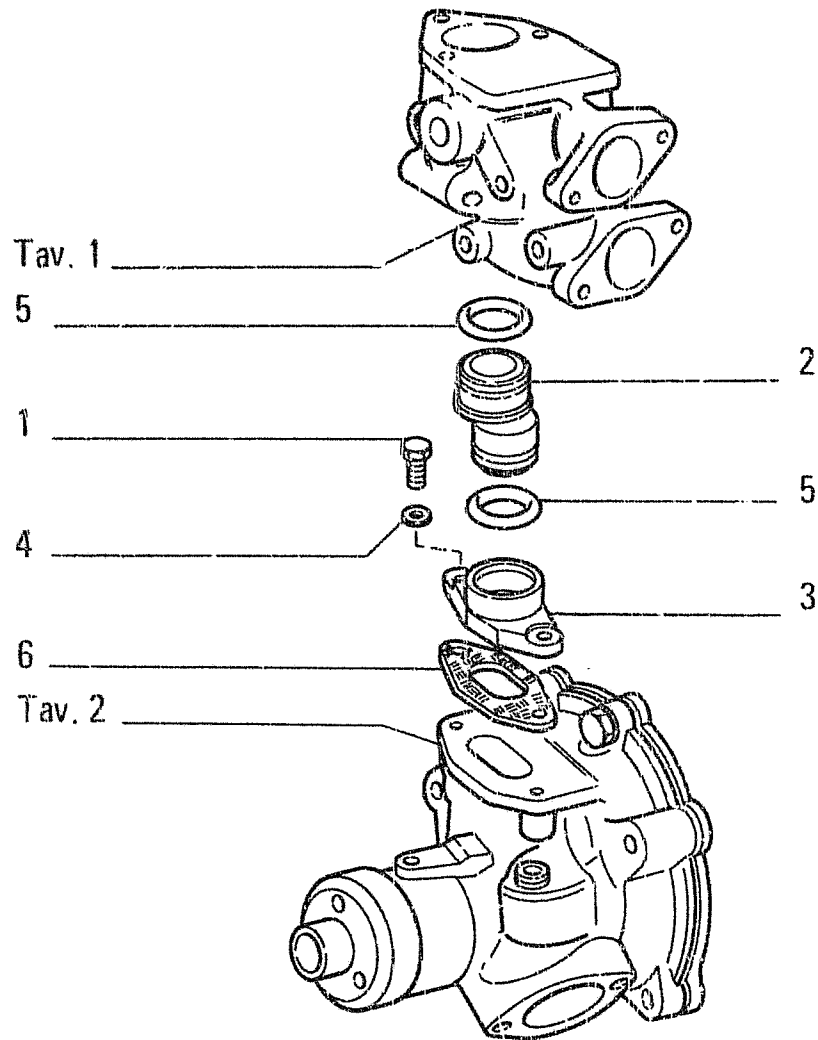

ITEM	PART NUMBER	QTY	TRANS CODE	DESCRIPTION	DESCRIZIONE
1	4798845	2	40V	SCREW	VITE
2	4859907	1	20R	FITTING - UPPER	RACCORDO - SUPERIORE
3	4859908	1	20R	FITTING - LOWER	RACCORDO - INFERIORE
4	14496521	2	131R	WASHER 8.4x17	ROSETTA 8.4x17
5	17288681	2	158G	O-RING	GUARNIZIONE O-R
6	98417182	1	122G	SEAL	GUARNIZIONE

D3350 Mot.n. 472392 →

WATER PUMP AND LINES - POMPA ACQUA E TUBAZIONI - POMPE ET CANALISATIONS D'EAU -
 WASSERPUMPE UND LEITUNGEN - BOMBA DE AGUA Y TUBERIAS

A4.02

2A

N.T.R. 205 - 30.09.1991
 604.111.081.06

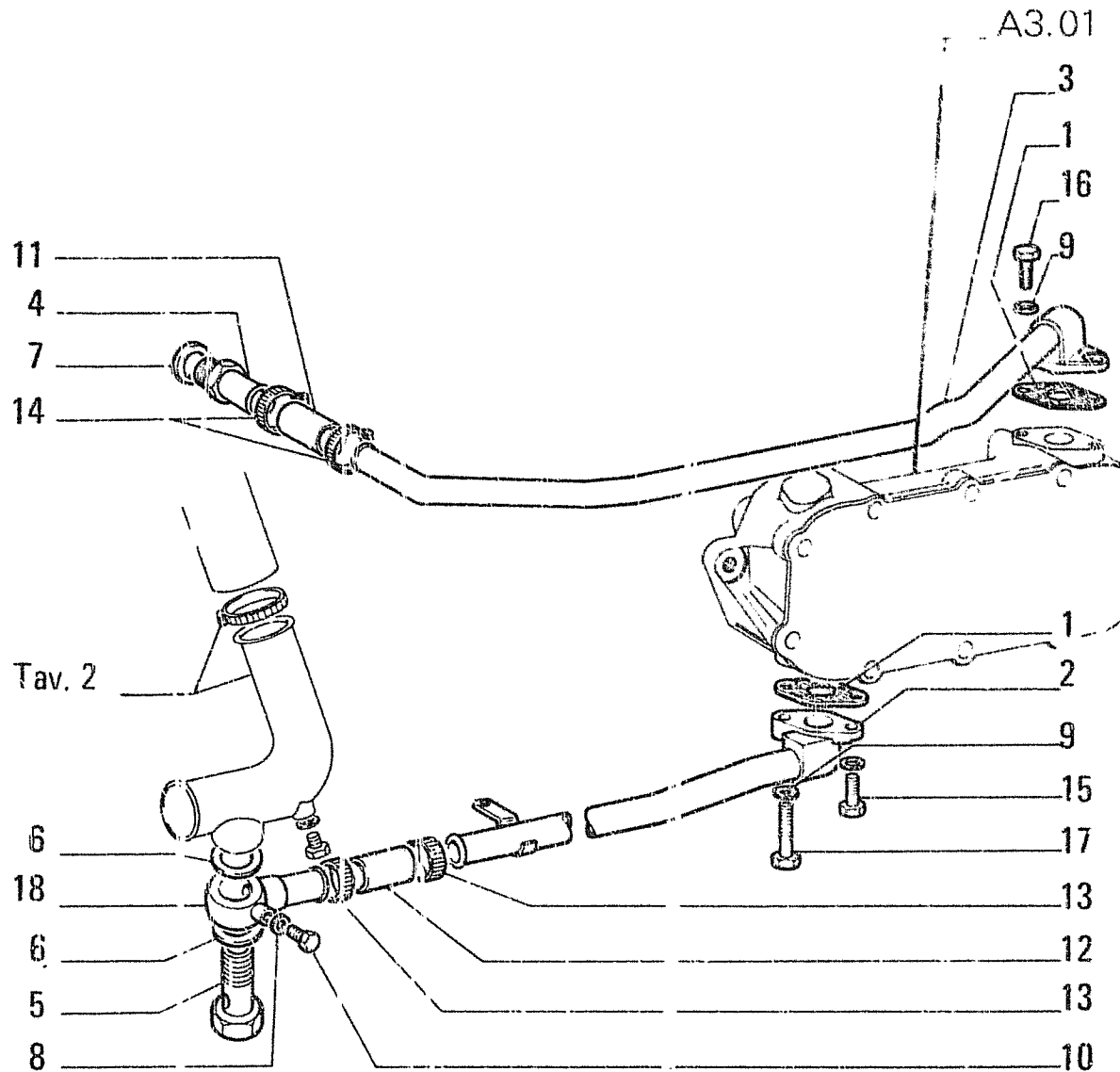

ITEM	PART NUMBER	QTY	TRANS CODE	DESCRIPTION	DESCRIZIONE
1	4724814	2	122G SEAL C3341	GUARNIZIONE C3341	
	4858087	2	122G SEAL D3341	GUARNIZIONE D3341	
2	4757577	1	193T TUBE C1572	TUBO RIGIDO C1572	
	4784790	1	193T TUBE D1572	TUBO RIGIDO D1572	
3	4757617	1	193T TUBE C1572	TUBO RIGIDO C1572	
	4784788	1	193T TUBE D1572	TUBO RIGIDO D1572	
4	4760312	1	20R FITTING	RACCORDO	
5	10184517	1	20R FITTING 24x1,5x14,5	RACCORDO 24x1,5x14,5	
6	10257385	2	133R SEAL 24x32	ROSETTA DI TENUTA 24x32	
7	10257460	1	133R SEAL 20,2x26	ROSETTA DI TENUTA 20,2x26	
8	10287385	1	133R SEAL 12,2x18	ROSETTA DI TENUTA 12,2x18	
9	11193871	4	132P LOCKWASHER 8,4x16	ROSETTA DI SICUREZZA 8,4x16	
10	11903211	1	50T PLUG 12x1,25x8	TAPPO 12x1,25x8	
11	12077086	2	30M SLEEVE 18x60 C2906	MANICOTTO 18x60 C2906	
	76014938	1	2P5T HOSE 0,080M D2906	TUBO FLESSIBILE 0,080M D2906	
12	12077186	1	30M SLEEVE 18x80	MANICOTTO 18x80	
13	12173890	1	180C COLLAR 24/36x14 C1572	COLLARE 24/36x14 C1572	
	12182190	4	180C COLLAR 27/23,5 D1572	COLLARE 27/23,5 D1572	
14	12179990	2	180C COLLAR 18/28x8 C2906	COLLARE 18/28x8 C2906	
	79083842	2	180C COLLAR D2906	COLLARE D2906	
15	16043421	1	40V SCREW 8x1,25x20	VITE 8x1,25x20	
16	16043621	2	40V SCREW 8x1,25x25	VITE 8x1,25x25	
17	16043921	1	40V SCREW 8x1,25x35	VITE 8x1,25x35	
18	79022226	1	20R FITTING	RACCORDO	

WATER PUMP AND LINES — POMPA ACQUA E TUBAZIONI — POMPE ET CANALISATIONS D'EAU —
 WASSERPUMPE UND LEITUNGEN — BOMBA DE AGUA Y TUBERÍAS

A4.02

3

N.T.R. 200 - 15.10.1990

604.01.081.05

P7

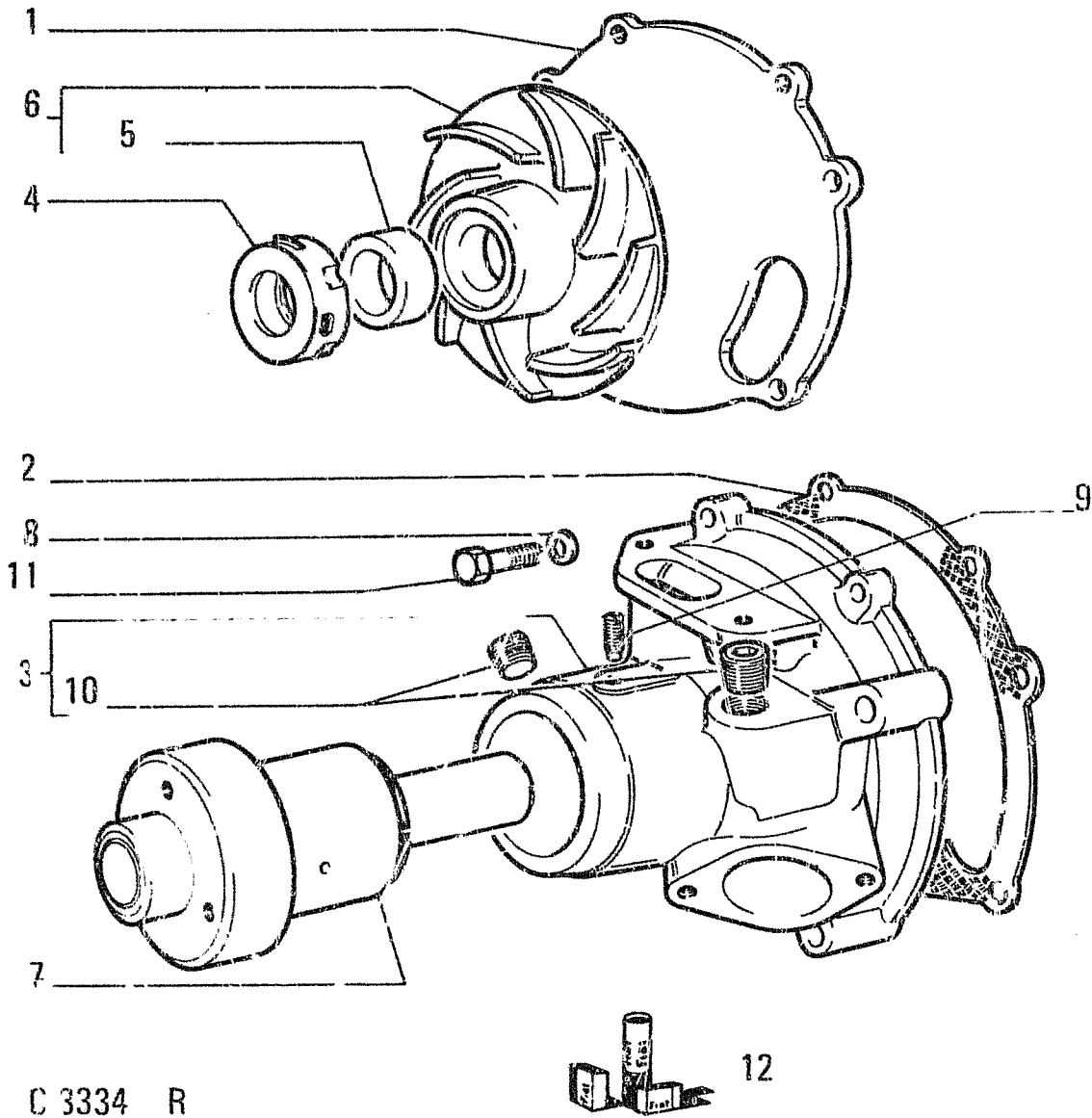

C 3334 R

4679242 - 4784454

WATER PUMP - POMPA ACQUA - POMPE A EAU - WASSERPUMPE - BOMBA DE AGUA

ITEM	PART NUMBER	QTY	TRANS CODE	DESCRIPTION	DESCRIZIONE
1	4599557	1	265C	COVER	COP. CH.
2	4599560	1	123G	SEAL ASSY C3342	GUARNIZIONE TENUTA FRONTALE C3342
	4858074	1	122G	SEAL D3342	GUARNIZIONE D3342
3	4603862	1	300C	BODY - ASSEMBLY C1572	CORPO - COMPLETO C1572
	4784008	1	300C	BODY - ASSEMBLY D1572	CORPO - COMPLETO D1572
4	4603870	1	158G	O-RING C1572	GUARNIZIONE O-R C1572
	4706880	1	158G	O-RING D1572	GUARNIZIONE O-R D1572
5	4639096	1	35B	BUSHING C1572	BOCCOLA C1572
	4706879	1	35B	BUSHING D1572	BOCCOLA D1572
6	4639097	1	60G	IMPELLER - ASSEMBLY C1572	GIRANTE - COMPLETO C1572
	4770614	1	60G	IMPELLER - ASSEMBLY D1572	GIRANTE - COMPLETO D1572
7	4655011	1	16A	SHAFT C1572	ALBERO C1572
	4724078	1	16A	SHAFT D1572	ALBERO D1572
8	11193871	2	132R	LOCKWASHER 8,4x16	ROSETTA DI SICUREZZA 8,4x16
9	13748610	1	40V	SCREW 8x1,25x16 C1572	VITE 8x1,25x16 C1572
	13748710	1	40V	SCREW D1572	VITE D1572
10	14325011	2	50T	PLUG 16x1,5x13	TAPPO 16x1,5x13
11	16043421	2	40V	SCREW 8x1,25x20	VITE 8x1,25x20
12	79046186	1	1K	KIT SEE PAGE 9 C1572	KIT VED. PAG 9 C1572

A4.03

N.T.R. 200-15.10.1990

604.01.031.05

FIATALLIS FD7

A4.03/ A TAV. 1 PAG.1

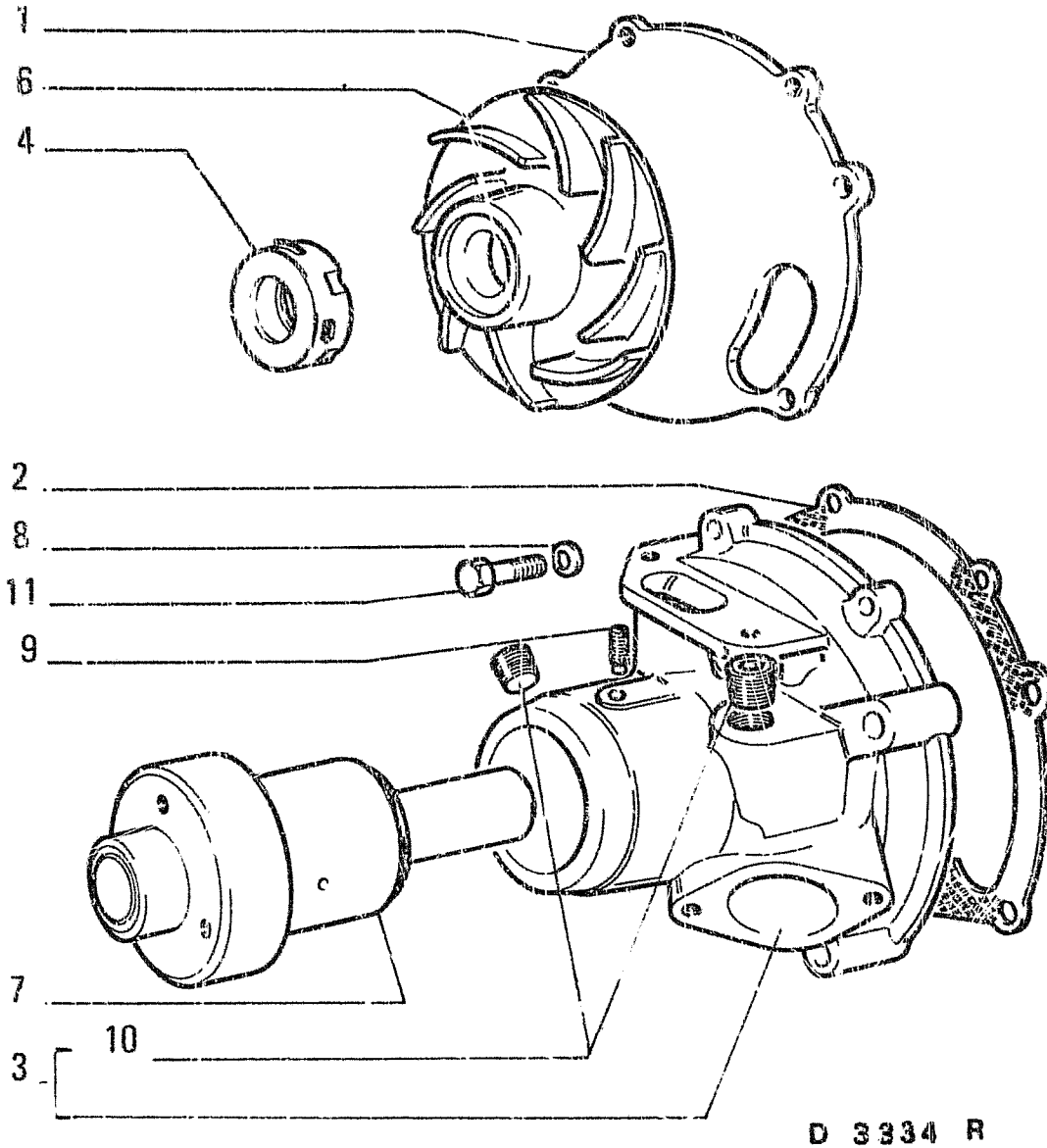

ITEM	PART NUMBER	QTY	TRANS CODE	DESCRIPTION	DESCRIZIONE
1	4599557	1	265C	COVER	COPERCHIO
2	4858074	1	120G	GASKET	GUARNIZIONE PIANA
3	4801610	1	300C	BODY - ASSEMBLY	CORPO - COMPLETO
4	7302756	1	122G	SEAL - IN ALTERNATIVE	GUARNIZIONE - IN ALTERNATIVA
	7302776	1	122G	SEAL - IN ALTERNATIVE	GUARNIZIONE - IN ALTERNATIVA
6	4813442	1	60G	IMPELLER	GI-FANTE
7	4829218	1	16A	SHAFT	ALBERO
8	11193871	2	131R	WASHER 8,4x16	ROSETTA 8,4x16
9	13739811	1	40V	SCREW	VITE
10	14325011	2	50T	PLUG 16x1,5x13	TAPPO 16x1,5x13
11	16043421	2	40V	SCREW 8x1,25x20	VITE 8x1,25x20

4813370

WATER PUMP - POMPA ACQUA -- POMPE A EAU -- WASSERPUMPE -- BOMBA DE AGUA

A4.03/A

N.T.R. 200 - 15.10.1990

604.01.081.05

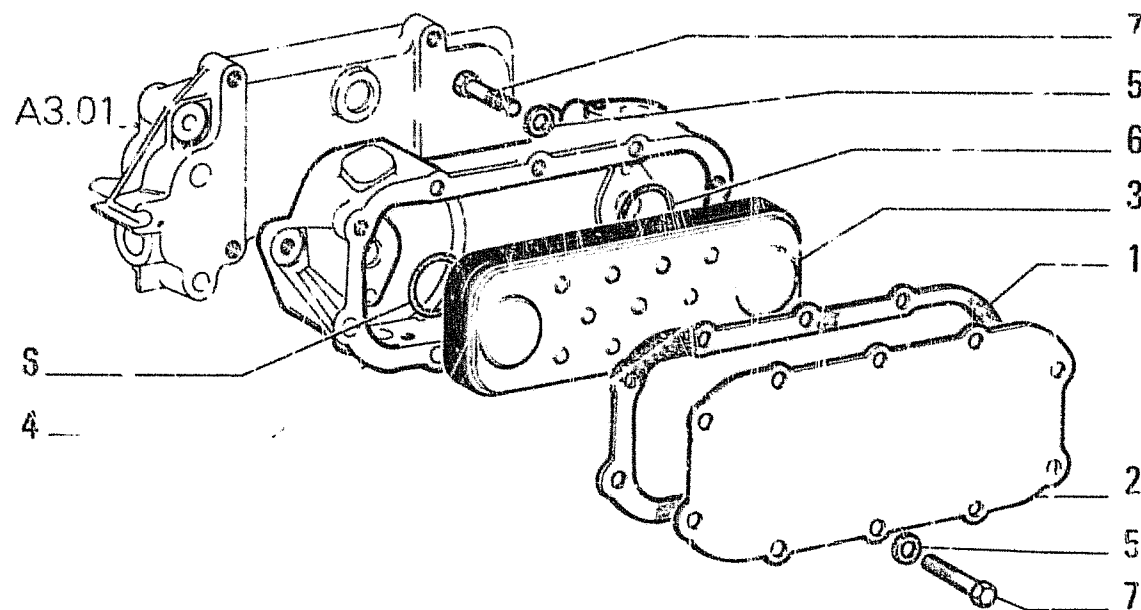

ITEM	PART NUMBER	QTY	TRANS CODE	DESCRIPTION	DESCRIZIONE
1	4724223	1	123G	SEAL ASSY C3341	GUARNIZIONE TENUTA FRONTALE C3341
	4858089	1	122G	SEAL D3341	GUARNIZIONE D3341
2	4724224	1	265C	COVER	COPRICHIO
3	4724553	1	300C	BODY - INNER	CORPO - INTERNO
4	4757575	1	35S	CASE C1572	SCATOLA C1572
	4784793	1	35S	CASE D1572	SCATOLA D1572
5	10519601	4	131R	WASHER 8,15x17 D1572	ROSETTA 8,15x17 D1572
	11193871	5	131R	WASHER 8,4x16 D1572	ROSETTA 8,4x16 D1572
	11198071	9	132R	LOCKWASHER 8,2x15 C1572	ROSETTA DI SICUREZZA 8,2x15 C1572
6	14458281	2	158G	O-RING 2,62x31,42	GUARNIZIONE O-R 2,62x31,42
7	16043221	9	40V	SCREW 8x1,25x16	VITE 8x1,25x16

HEAT EXCHANGER - SCAMBIATORE DI CALORE - ECHANGEUR DE CHALEUR - WAERMETAUSCHER - CAMBIADOR DE CALOR

A4.04

N.T.R. 200 - 15.10.1990

604.01.081.05

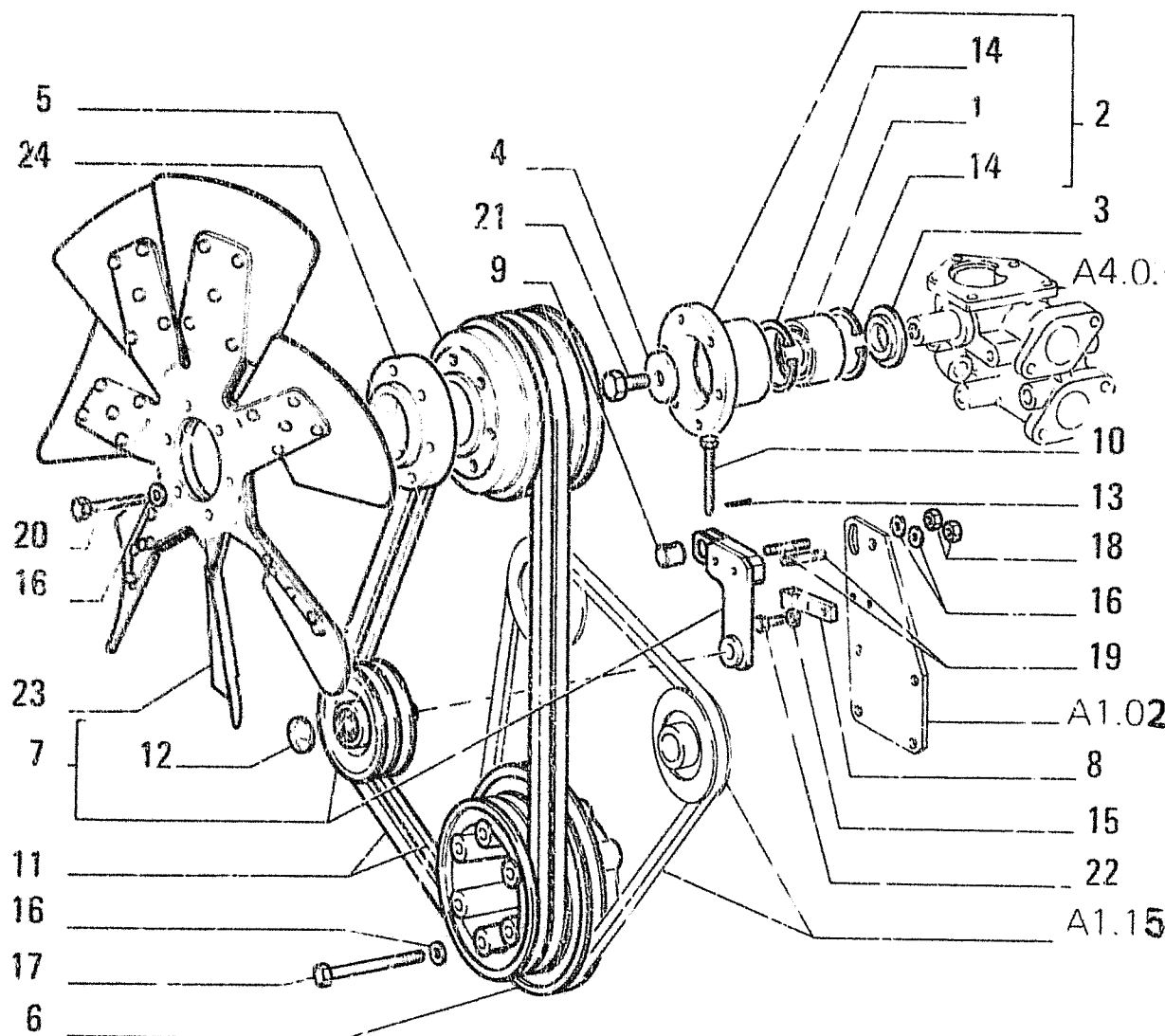

ITEM	PART NUMBER	QTY	TRANS CODE	DESCRIPTION	DESCRIZIONE
1	4318965	1		341C BEARING	CUSCINETTO
2	4747161	1		135M HUB - ASSEMBLY C1572	MOZZO - COMPLETO C1572
	4772229	1		135M HUB - ASSEMBLY D1572	MOZZO - COMPLETO D1572
3	4747163	1		131R WASHER C1572	ROSETTA C1572
	4772231	1		131R WASHER D1572	ROSETTA D1572
4	4747164	1		131R WASHER	ROSETTA
5	4758241	1		230P PULLEY C1572	PULEGGIA C1572
	4812091	1		230P PULLEY D1572	PULEGGIA D1572
6	4764863	1		230P PULLEY	PULEGGIA
7	4765344	1		87T BELT STRETCHER - ASSEMBLY C1572	TENDICINGHIA - COMPLETO C1572
	4809354	1		87T BELT STRETCHER - ASSEMBLY D1572	TENDICINGHIA - COMPLETO D1572
8	4765345	1		231S CLIP	STAFFETTA
9	4765346	1		80P PIN	PERNO
10	4765347	1		40V SCREW	VITE
11	4765504	S		174C BELTS C1572	CINGHIE C1572
	4795708	S		174C BELTS D1572	CINGHIE D1572
		S		174C BELTS C2958	CINGHIE C2958
		1		174C BELTS D3343	CINGHIE D3343
	4813541	S		174C BELTS D2958	CINGHIE D2958
		1		174C BELTS C3343	CINGHIE C3343
12	10160401	1		50T PLUG 35x2	TAPPO 35x2
13	10734308	1		270C COTTER PIN 1,7x24,5	COPIGLIA 1,7x24,5
14	11061576	2		51A LOCKRING 76,5x2,5	ANELLO DI SICUREZZA 76,5x2,5
15	11193871	2		132R LOCKWASHER 8,4x16	ROSETTA DI SICUREZZA 8,4x16
16	11198371	14		132R LOCKWASHER 10,5x20	ROSETTA DI SICUREZZA 10,5x20

FAN AND FAN DRIVE - VENTILATORE E SUO COMANDO - VENTILATEUR ET SA COMMANDE - LUEFTER UND LUEFTERANTRIEB - VENTILADOR Y SU MANDO

A4.09
N.T.R. 200 - 15.10.1990
604.01.081.05

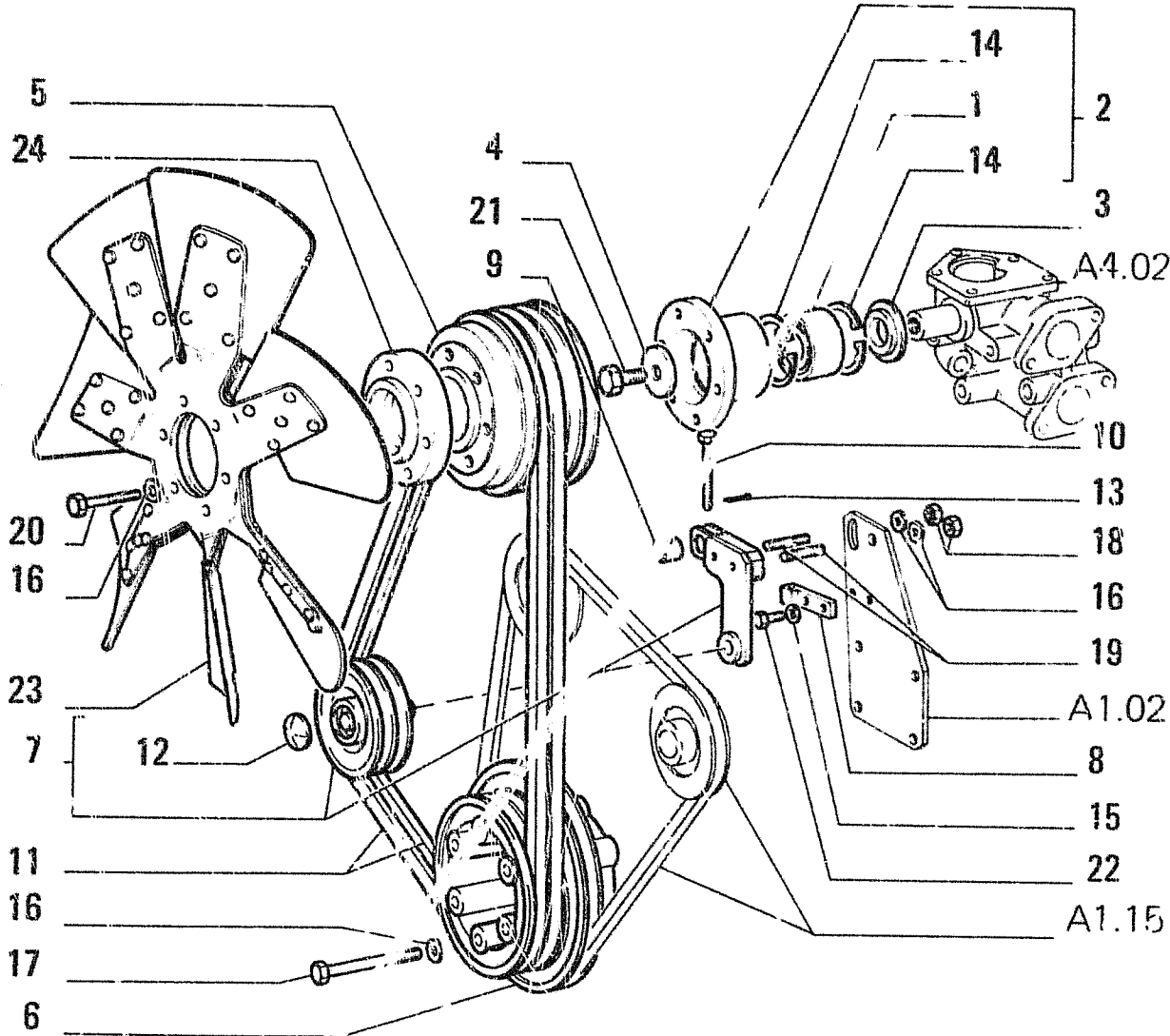

ITEM	PART NUMBER	QTY	TRANS CODE	DESCRIPTION	DESCRIZIONE
	17	6	40V	SCREW 10x1,25x65 C1572	VITE 10x1,25x65 C1572
	15971924	6	40V	SCREW 10x1,25x105 D1572	VITE 10x1,25x105 D1572
	18	2	10D NU	10x1,25x8	DADO 10x1,25x8
	19	2	210P	STUD 10x1,25x40	PRIGIONIERO 10x1,25x40
	20	6	40V	SCREW 10x1,25x70	VITE 10x1,25x70
	21	1	40V	SCREW 20x1,5x40	VITE 20x1,5x40
	22	2	40V	SCREW 8x1,25x20	VITE 8x1,25x20
	23	1	30V	FAN D1586	VENTILATORE D1586
	79035170	1	30V	FAN C1586	VENTILATORE C1586
	24	1	75D	SPACER	DISTANZIALE

FAN AND FAN DRIVE – VENTILATORE E SUO COMANDO – VENTILATEUR ET SA COMMANDE – LUEFTER UND LUEFTERANTRIEB – VENTILADOR Y SU MANDO

1
A4.09
N.T.R. 200 - 15.10.1990
604.01.081.05

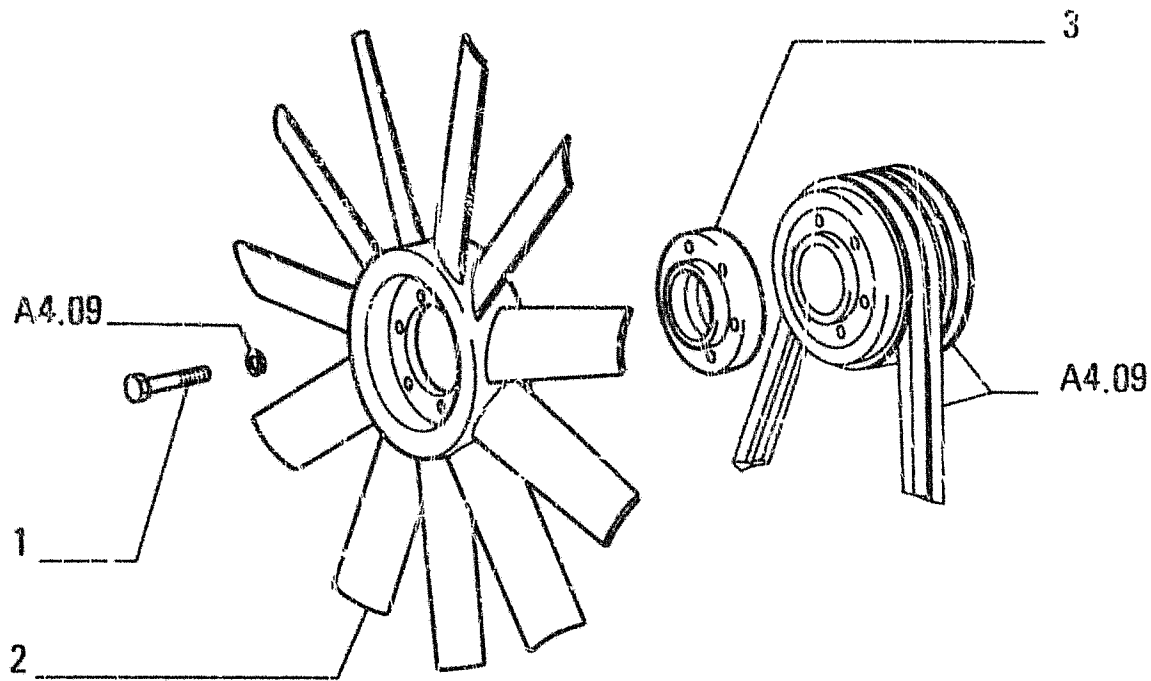

ITEM	PART NUMBER	QTY	TRANS CODE	DESCRIPTION	DESCRIZIONE
1	15971731	6	40V	SCREW 10x1,25x95	VITE 10x1,25x95
2	76018081	1	30V	FAN	VENTILATORE
3	79035175	1	75D	SPACER	DISTANZIALE

OPTIONAL VARIANTE 30.0022.31.1

D 3214 Tel.n. 251871 →

FAN AND FAN DRIVE – VENTILATORE E SUO COMANDO – VENTILATEUR ET SA COMMANDE – LUEFTER UND LUEFTERANTRIEB – VENTILADOR Y SU MANDO

A4.09/1
N.T.R. 200 - 15.10.1990
604.01.081.05

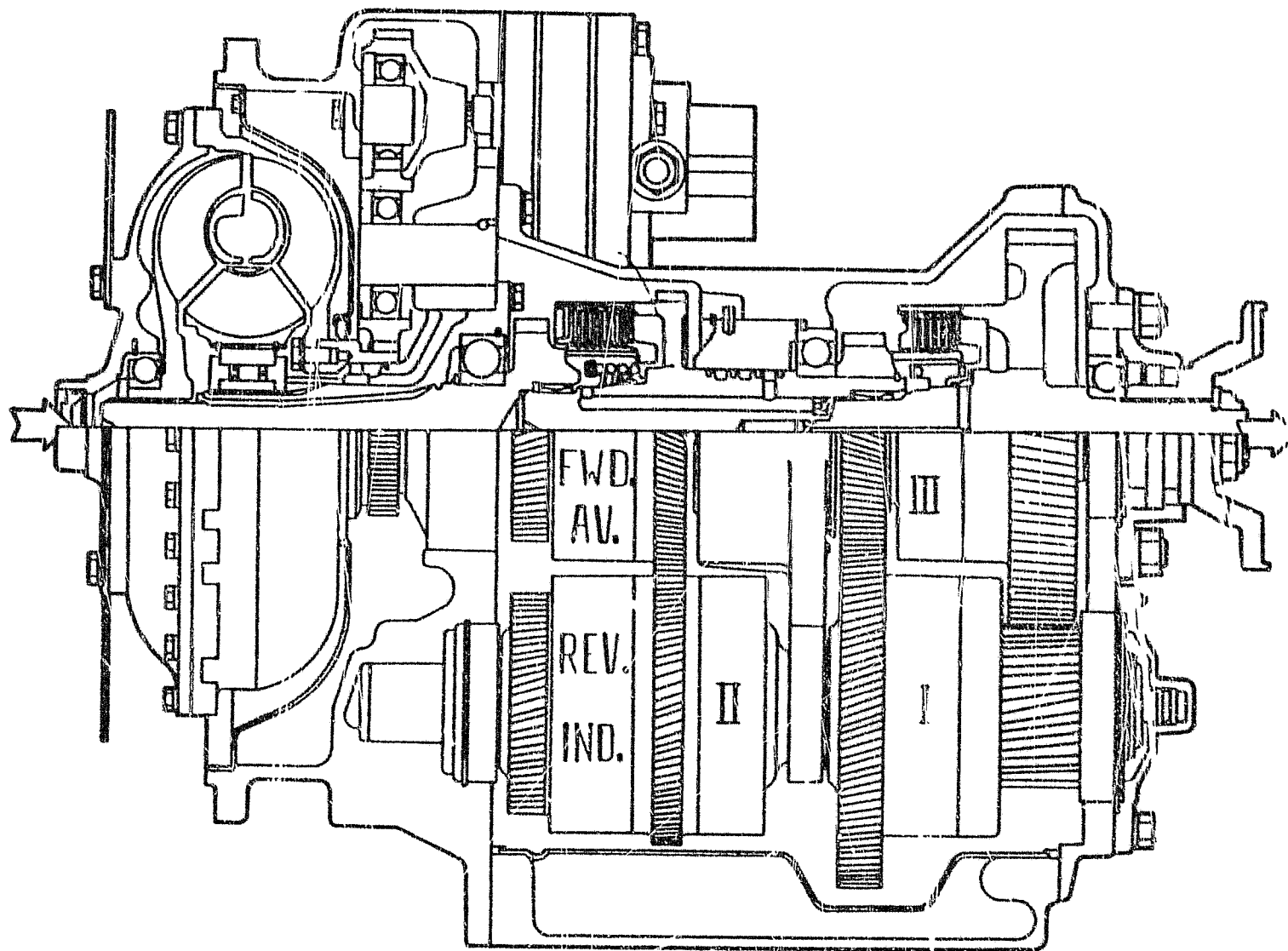

TRANSMISSION - CAMBIO DI VELOCITA' - BOITE DE VITESSES - WECHSELGETRIEBE - CAMBIO DE VELOCIDADES

B2.00

1

N.T.R. 205 30.09.1951
604.01.181.06

P14

210 A

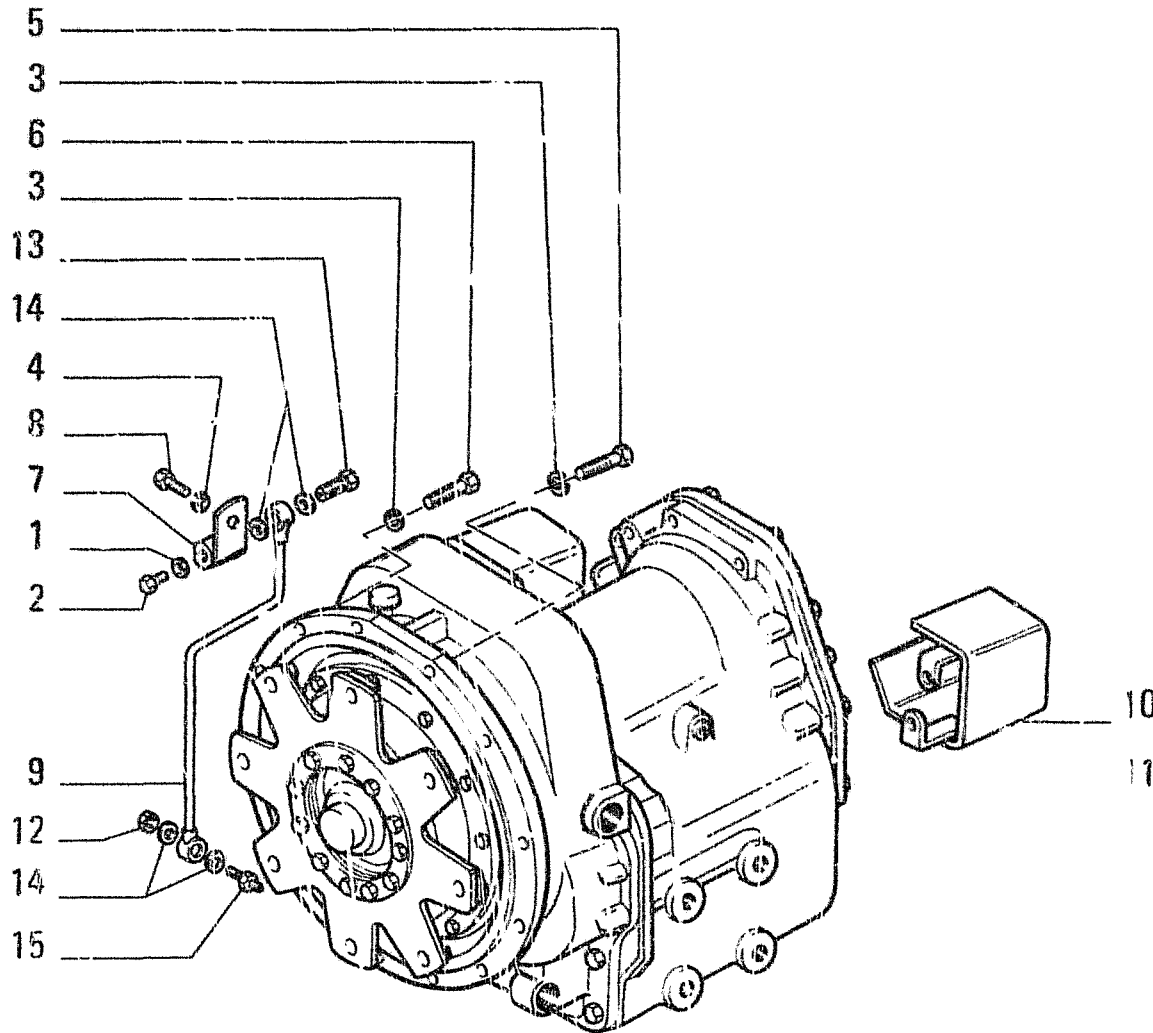

ITEM	PART NUMBER	QTY	TRANS CODE	DESCRIPTION	DESCRIZIONE
1	10296160	1	133R	SEAL 12,2x18	ROSETTA DI TENUTA 12,2x18
2	10300511	1	50T	PLUG 12x1,5x8	TAPPO 12x1,5x8
3	10516871	11	132R	LOCKWASHER 10x2,5	ROSETTA DI SICUREZZA 10x2,5
4	10517171	1	132R	LOCKWASHER 14,2x3,5	ROSETTA DI SICUREZZA 14,2x3,5
5	11307031	10	40V	SCREW 10x1,25x40	VITE 10x1,25x40
6	15970931	1	40V	SCREW 10x1,25x35	VITE 10x1,25x35
7	76002365	1	231S	CLIP	STAFFETTA
8	79020334	1	40V	SCREW	VITE
9	79020337	1	193T	TUBE	TUBO RIGIDO
10	79024798	1	70R	GUARE (*)	RIPARO (*)
11	79028189	1	30C	TRANSMISSION - ASSEMBLY SEE SGR. B2.01/1 (*) C1510	CAMBIO VELOCITA' - COMPLETO VEDERE SGR. B2.01/1 (*) C1510
		1	30C	TRANSMISSION - ASSEMBLY SEE SGR. B2.01 C1532	CAMBIO VELOCITA' - COMPLETO VEDERE SGR. B2.01 C1532
	79057724	1	30C	TRANSMISSION - ASSEMBLY SEE SGR. B2.01/A D1532	CAMBIO VELOCITA' - COMPLETO VEDERE SGR. B2.01/A D1532
		1	30C	TRANSMISSION - ASSEMBLY SEE SGR. B2.01/A C1510	CAMBIO VELOCITA' - COMPLETO VEDERE SGR. B2.01/A C1510
	79064264	1	30C	TRANSMISSION - ASSEMBLY SEE SGR. B2.01/1A (*) D1510	CAMBIO VELOCITA' - COMPLETO VEDERE SGR. B2.01/1A (*) D1510
	79064265	1	30C	TRANSMISSION - ASSEMBLY SEE SGR. B2.01/B D1510	CAMBIO VELOCITA' - COMPLETO VEDERE SGR. B2.01/B D1510

TRANSMISSION - CAMBIO DI VELOCITA' - BOITE DE VITESSES WECHSELGETRIEBE - CAMBIO DE VELOCIDADES

1

B2.00

2

N.T.F. 205 - 30.09.1991
604.01.081.06

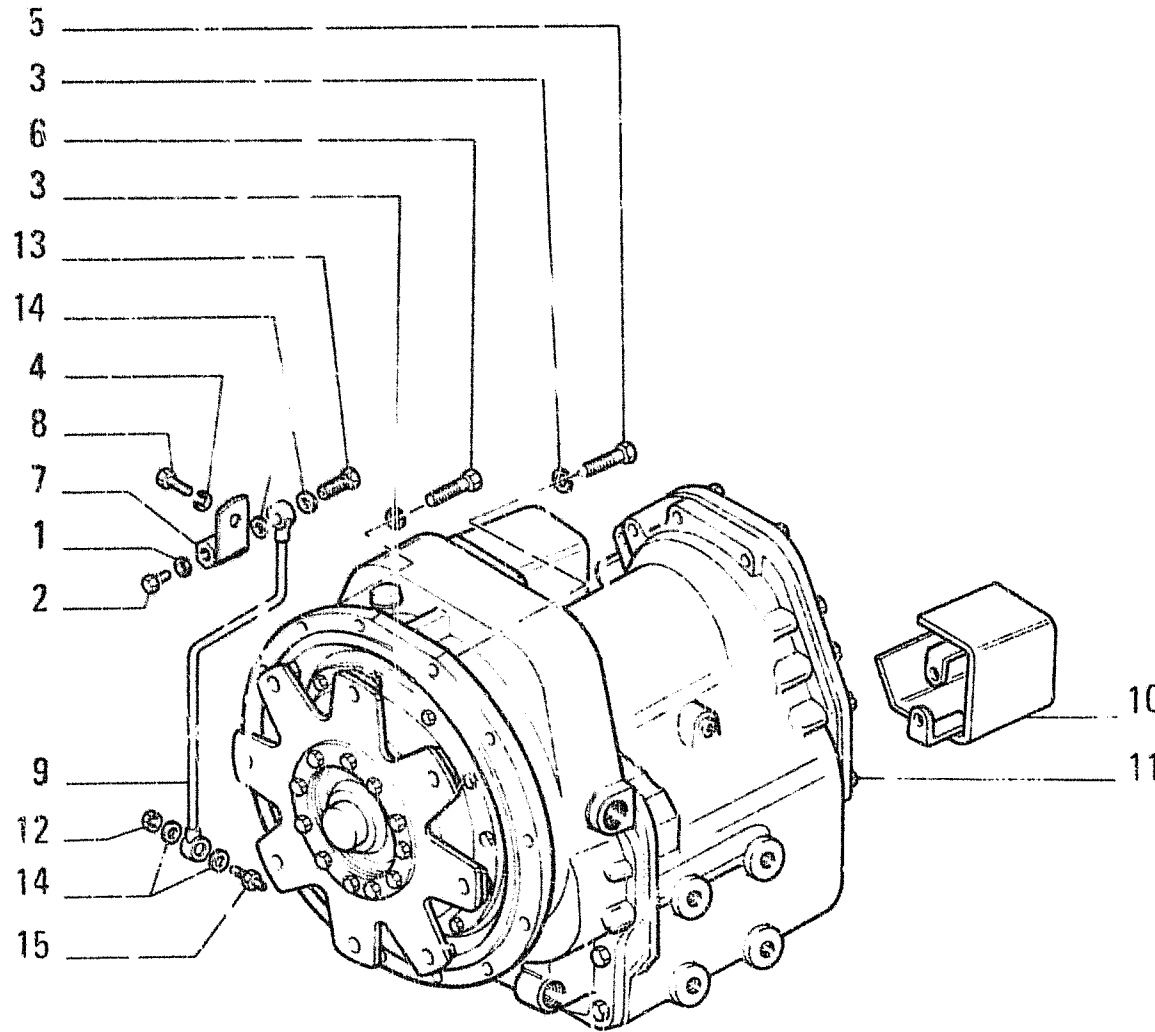

ITEM	PART NUMBER	QTY	TRANS CODE	DESCRIPTION	DESCRIZIONE
12	11902017	1	50T	PLUG 8x1,25x11	TAPPO 8x1,25x11
13	11903717	1	20R	FITTING 8x1,25x16	RACCORDO 8x1,25x16
14	14330260	4	133R	SEAL 8,2x12	ROSETTA DI TENUTA 8,2x12
15	79014681	1	20R	FITTING	RACCORDO
(*)			469P	FOR SPECIAL EQUIPMENT	PER VARIANTE 30.0289.02.1
				30.0289.02.1	

TRANSMISSION - CAMBIO DI VELOCITA' - BOITE DE VITESSES WECHSELGETRIEBE - CAMBIO DE VELOCIDADES

B2.00 2
 N.T.R. 205 - 30.09.1991
 604.01.081.06

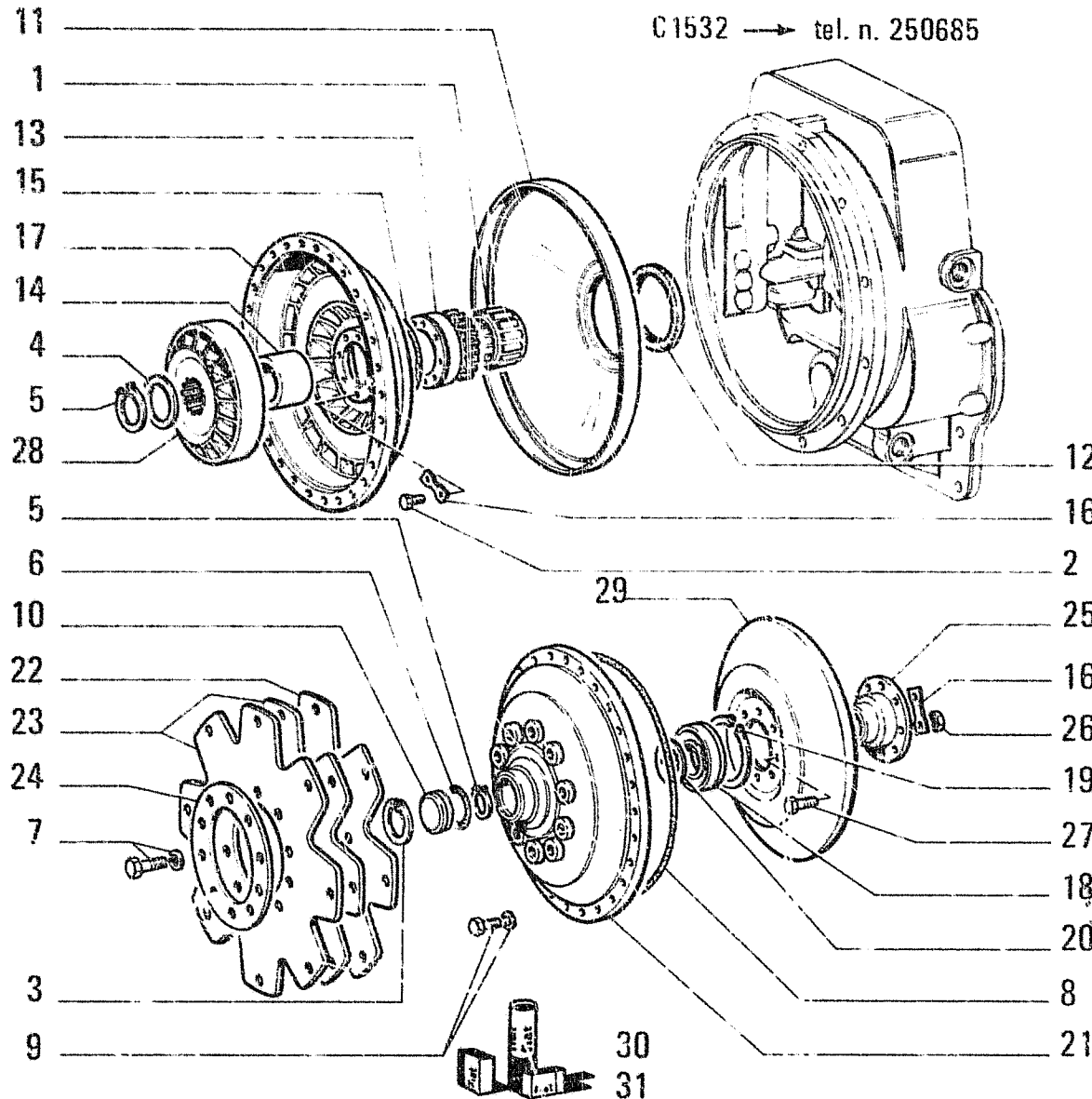

ITEM	PART NUMBER	QTY	TRANS CODE	DESCRIPTION	DESCRIZIONE
1	70873970	1	341C BEARING		CUSCINETTO
2	70927211	8	40V SCREW		VITE
3	70927696	1	51A LOCKRING C1169		ANELLO DI SICUREZZA C1169
	70935974	1	51A LOCKRING D1169		ANELLO DI SICUREZZA D1169
4	70927747	1	45A RING		ANELLO
5	70928720	2	51A LOCKRING		ANELLO DI SICUREZZA
6	14458580	1	158G O-RING 2.62x36.17 D1171		GUARNIZIONE O-R 2,62x36,17 D1171
	70933876	1	158G O-RING C1171		GUARNIZIONE O-R C1171
7	71004835	10	44V SCREW AND WASHER ASSY		VITE CON ROSETTA
8	71005536	1	153G O-RING		GUARNIZIONE O-R
9	71008468	24	44V SCREW AND WASHER ASSY		VITE CON ROSETTA
10	73117963	1	50T PLUG		TAPPO
11	73118063	1	20D DEFLECTOR		DEFLETTORE
12	73118064	1	123G SEAL ASSY		GUARNIZIONE TLUATA FRONTALE
13	73118065	1	50I GEAR		INGRANAGGIO
14	73118066	1	75D SPACER		DISTANZIALE
15	73118067	1	158G O-RING		GUARNIZIONE O-R
16	73118068	8	110P PLAQUE		PIASTRINA
17	73118069	1	60G IMPELLER		GIRANTE
18	73118072	1	341C BEARING		CUSCINETTO
19	73118073	1	51A LOCKRING		ANELLO DI SICUREZZA
20	73118074	1	131R WASHER		ROSETTA
21	73118075	1	265C COVER C1169		COPERCHIO C1169
	73132674	1	265C COVER D1169		COPERCHIO D1169

79028189

9

TRANSMISSION - CAMBIO DI VELOCITA' - BOITE DE VITESSES - WECHSELGETRIEBE - CAMBIO DE VELOCIDADES

B2.01

1

N.T.R. 191 - 20.02.1990

604.01.081.04

DESIGNAZIONE BASE	BASIC DESIGNATION	DESIGNATION-BASES	GRUNDBEZEICHNUNGEN	DEMINICACIONES BASE	
9007	IMP. PROTEZIONE MOTORE	ENGINE PROTECTION			
9016	ALLESTIMENTO USAF	USAF PROVISION			
9119	SENZA CILINDRI SOLLIVAMENTO	LIFT CYLINDERS DEDUCTION	SANS CYLINDRES SOULEVEMENT	OHNE HUBZYLINDER	
9113	SENZA TUBAZ E CILINDRI SOLLEV	LIFT CYLINDERS & PIPING DEDUCT	SANS TUYAUT ET SYL SOUL.	OHNE LEITUNGEN UND HUBZYLINDER	
9115	BLOCCAGGIO ART COLAZ BRACCI	BOOM LINKAGE LOCK	BLOCCAGE ARTICULATION BRAS	MÜHDESTÄNGEGARRETIERUNG	
9118	ALLESTIMENTO FINA	FINA PROVISION			
0117	PREPARAZIONE R SPEDIZIONE	SHIPPING PREPARATION			
9130	SENZA DISPOSITIVO EQUISTATIC	EQUISTATIC DEVICE DEDUCTION	SANS DISPOSITIF EQUISTATIQUE	OHNE EQUISTATIK	
9150	SENZA VERNICIATURA A SMALTO				
9200	SENZA BOZZELLI GANCIO	HOOK SHEAVES DEDUCTION	SANS MOULE DE CROCHET	OHNE HAKENSEILBLOCK	
9206	SPECIAL CONTRACT	SPECIAL CONTRACT			
9220	SENZA ZAVORRE POSTERIORI	REAR COUNTERWEIGHT DEDUCTION	SANS LESTS ARRIERES	OHNE KONTERGEWICHT HINTER	
9225	SENZA COMANDO FREE FALL	FREE FALL CONTROL DEDUCTION	SANS COMMANDE FREE FALL	OHNE FREIFALL-EINRICHTUNG	
9230	SENZA ZAVORRA E SOPPORTO (ANT)		SANS LEST ET SUPP (AV)	OHNE KONTERGEWICHT/KONSOLE VOR	
9232	SENZA ZAVORRE LATERALI	SIDE COUNTERWEIGHT DEDUCTION	SANS LESTS LATERAUX	OHNE SEITLICHES KONTERGEWICHT	
9242	SENZA PNEUMATICI	TIRE OMISSION	SANS PNEUS	OHNE REIFEN	
9491	SENZA PNEUMATICI E CERCHI	TIRE AND WHEEL OMISSION	SANS PNEUS ET CERCLES	OHNE REIFEN UND FELGEN	
9506	SENZA SUOLE	SHOES DEDUCTION	SANS PATINS	OHNE KETTENPLATTEN	
9512	SENZA CATENARIA E SUOLE	TRACK CHAIN & SHOES DEDUCTION	SANS CHENILLE ET PATINS	OHNE KETTENZUG UND PLATTEN	
9580	SENZA CABIN	CAB OMISSION			
9602	SENZA RISCALDATORE	HEATER DEDUCTION	SANS CHAUFFAGE	OHNE HEIZUNG	
9633	SENZA EMERGENCY STEERING	EMERGENCY STEERING DEDUCTION	SANS DIRECTION D'EMERGENCE	OHNE NOTLENKUNG	
9764	FORNITURE ESTERNE	PURCHASED FINISH (P.F.)			
9765	COMANDO MOTORE (PF MOTORE)	ENGINE CONTROLS (ENGINE PF)		MOTORSTEUERUNG	
9761	SENZA BACK UP ALARM	BACK UP ALARM DEDUCTION	SANS BACK UP ALARM	OHNE RUECKFAHRWARNANLAGE	
9860	TARGHE E MANUALI	MANUALS AND DECALS	PLAQUES ET MANUELS	KLEBESCHILDER UND HANDBÜCHER	
9861	TARGHE D'IDENTIFICAZIONE	IDENTIFICATION PLATES	PLAQUE D'IDENTIFICATION	TYPENSCHILDER	
9862	MARCHI DELLA DITTA	TRADE MARKS		FIRMENZEICHEN	
9868	SENZA INNESTAMENTO SEDILE				
9850	SENZA SEDILE	SEAT DEDUCTION	SANS SIEGE	OHNE SITZ	
9851	SENZA SEDILE E SOPPORTO	SEAT AND PEDESTAL DEDUCTION	SANS SIEGE ET SUPPORT	OHNE SITZ UND KONSOLE	
9876	SENZA STRUTTURA PROTEZIONE	ROPS CANOPY DEDUCTION	SANS STRUCTURE DE PROTECTION	OHNE SCHUTZRAHMEN	SIN ESTRUCTURA DE PROTECCION
9890	SENZA BARRA DI TRAINO	SWINGING DRAWBAR DEDUCTION	SANS BARRE D'ATTelage	OHNE ZUGPENDEL	
9891	SENZA GANCIO TRAINO	DRAWBAR DEDUCTION	SANS CROCHET D'ATTALAGE	OHNE ZUGHAKEN	
9983	DOTAZIONI FINALI	FINAL PREPARATION			
9988	LUBRIFICANTI	LUBRICANTS	LUBRIFIANTS		

B

MECHANICAL TRANSMISSION • CLUTCH • TRANSMISSION • TRANSMISSION SHAFT • AXLES
TRASMISSIONE MECCANICA • FRIZIONE • CAMBIO • ALBERO DI TRASMISSIONE • PONTI
TRANSMISSION MECANIQUE • EMBRAYAGE • BOITE DE VITESSES • ARBRE DE TRANSMISSION • PONTS
MECHANISCHE KRAFTÜBERTRAGUNG • KUPPLUNG • GETRIEBE • GELENKWELLE • AXSEN
TRANSMISSION MECANICA • EMBRAGUE • CAMBIO • ARBOL DE TRANSMISSION • PUENTES

Q1

FITALLIS FD7

B2.01/ A Tav. 2 PAG.2

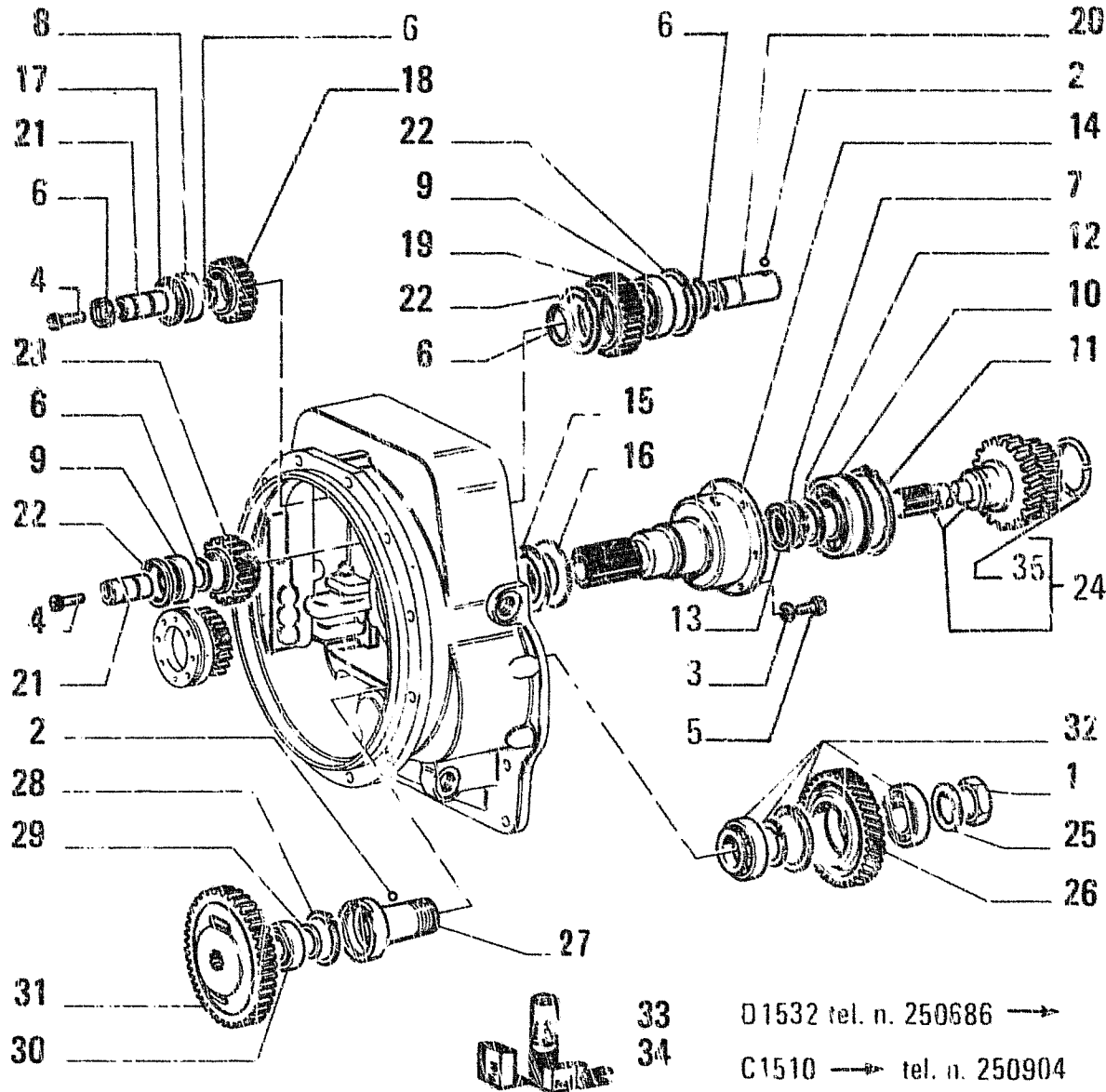

ITEM	PART NUMBER	QTY	TRANS CODE	DESCRIPTION	DESCRIZIONE
27	7900249	1	16A	SHAFT	ALBERO
28	79031250	1	51A	LOCKRING	ANELLO DI SICUREZZA
29	79030251	1	45A	RING	ANELLO
30	79030152	1	341C	BEARING	CUSCINETTO
31	79030253	1	50I	GEAR	INGRANAGGIO
32	79030261	1	341C	BEARING	CUSCINETTO
33	79055150	1	1K	KIT SEE PAGE 9	KIT VED. PAG.9
34	79055160	1	1K	KIT SEE PAGE 9	KIT VED. PAG.9
35	79064449	1	51A	LOCKRING	ANELLO DI SICUREZZA

33 D1532 tel. n. 250686 →
 34 C1510 → tel. n. 250904

79057724

TRANSMISSION - CAMBIO DI VELOCITA' - BOITE DE VITESSES - WECHSELGETRIEBE - CAMBIO DE VELOCIDADES

9
 B2.01/A 2
 N.T.R. 191 - 20.02.1990
 604.01.081.04

Q2

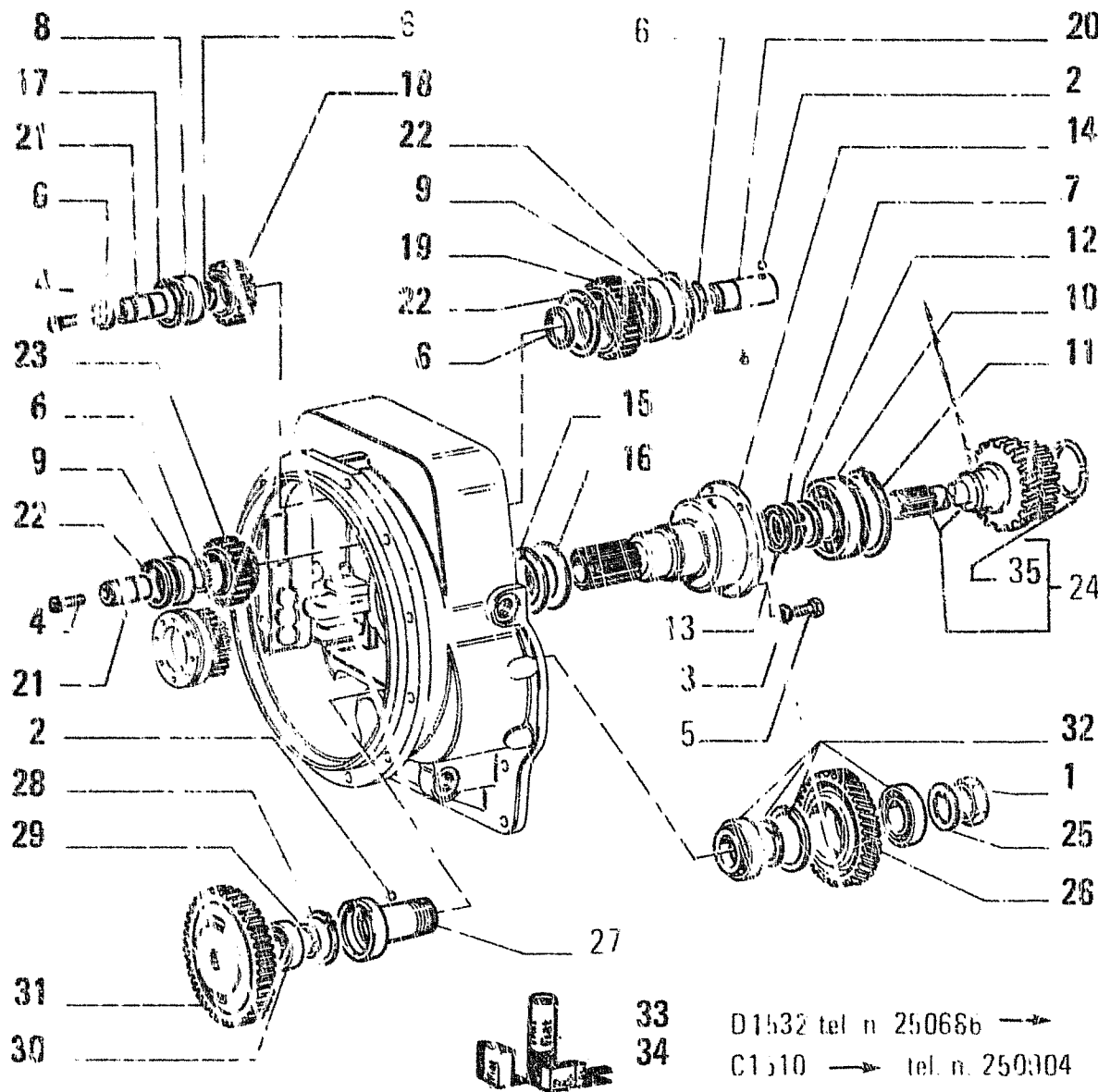

ITEM	PART NUMBER	QTY	TRANS CODE	DESCRIPTION	DESCRIZIONE
1	70059946	1	10D NUT		DADO
2	70673856	1	140S BALL		SFERA
3	10516879	6	170R LOCKWASHER 10,2x2,5		ROSETTA EL. 10,2x2,5
4	70921076	4	40V SCREW		VITE
5	70922763	6	40V SCREW		VITE
6	70929166	5	45A RING		ANELLO
7	73116957	1	51A LOCKRING		ANELLO DI SICUREZZA
8	73116959	1	341C BEARING		CUSCINETTO
9	73116971	2	341C BEARING		CUSCINETTO
10	73132932	1	341C BEARING		CUSCINETTO
11	73118057	1	51A LOCKRING		ANELLO DI SICUREZZA
12	73113058	2	131R WASHER		ROSETTA
13	73118059	1	45A RING		ANELLO
14	79059927	1	300S SUPPORT		SUPPORTO
15	73118061	1	45A RING C2911		ANELLO C2911
	79064451	1	45A RING D2911		ANELLO D2911
16	73118062	1	100M SPRING		MOLLA
17	73118080	1	45A RING		ANELLO
18	73118081	1	50I GEAR		INGRANAGGIO
19	73118082	1	50I GEAR		INGRANAGGIO
20	73118083	1	16A SHAFT		ALBERO
21	73118262	2	300S SUPPORT		SUPPORTO
22	73118320	3	45A RING		ANELLO
23	79030242	1	50I GEAR		INGRANAGGIO
24	79052635	1	16A SHAFT - ASSEMBLY		ALBERO - COMPLETO
25	79030247	2	131R WASHER		ROSETTA
26	79051101	1	50I GEAR		INGRANAGGIO

79057724

D1532 tel n 250686 →
 C1510 → tel. n. 250304

TRANSMISSION - CAMBIO DI VELOCITA' - BOITX DE VITESSES - WECHSELGETRIEBE - CAMBIO DE VELOCIDADES

9

B2.01/A

2

N.T.R. 191 - 20.02.1990
 604.01.081.04

01532 tel. n. 250686 →

01510 → tel. n. 250904

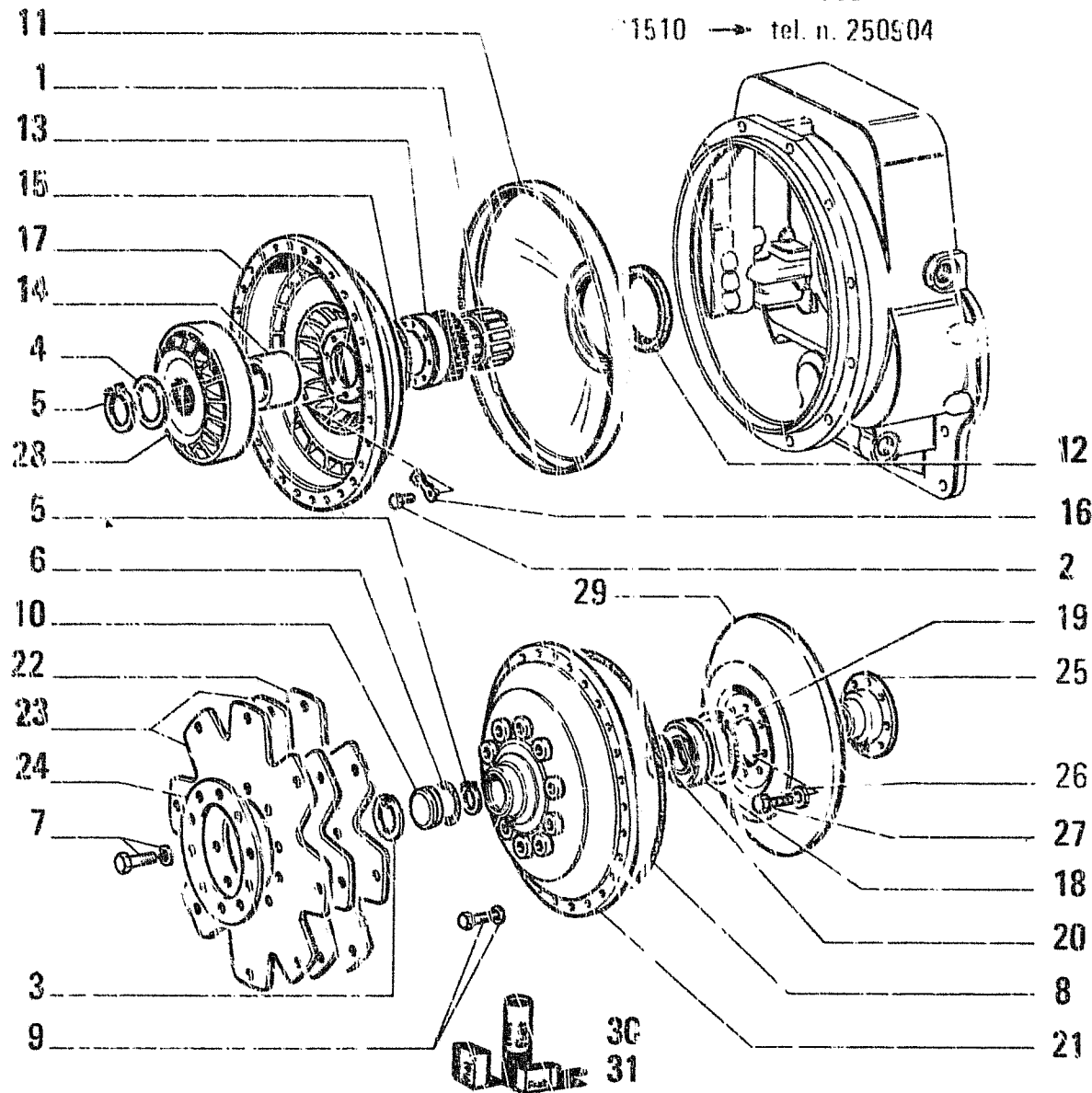

ITEM	PART NUMBER	QTY	TRANS CODE	DESCRIPTION	DESCRIZIONE
28	79)60011	1	271S	STATOR	STATORE
29	79)56360	1	60G	IMPELLER	DIRANTE
30	79)55159	1	1K	KIT SEE PAGE 9	KIT VED. PAG.9
31	79)55160	1	1K	KIT SEE PAGE 9	KIT VED. PAG.9

79057724

9

TRANSMISSION -- CAMBIO DI VELOCITA' -- BOITE DE VITESSES -- WEGSELGETRIEBE -- CAMBIO DE VELOCIDADES

B2.01/A

1

N.T.R. 191 - 20.02.1990

604.01.081.04

Q4

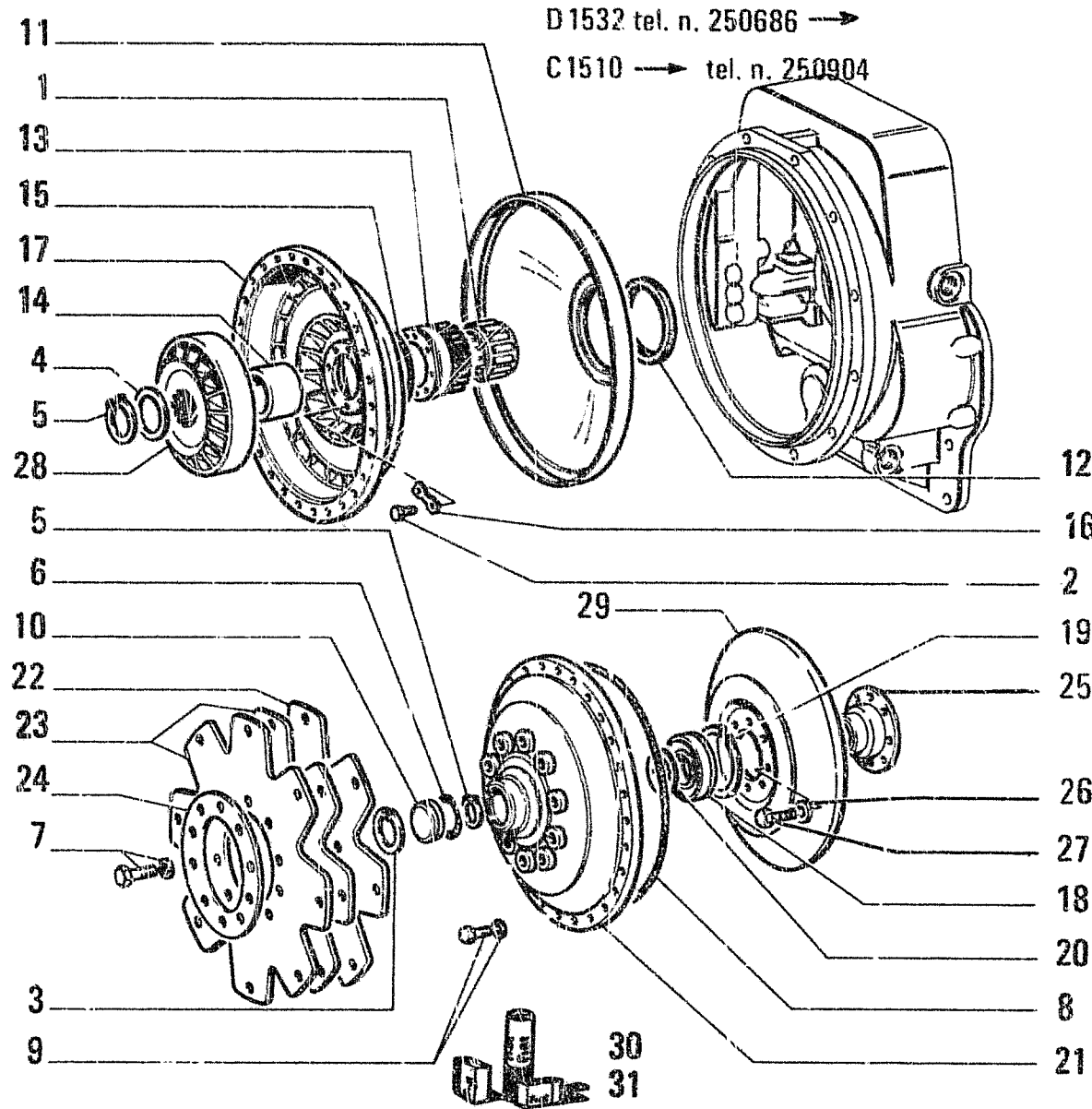

ITEM	PART NUMBER	QTY	TRANS CODE	DESCRIPTION	DESCRIZIONE
1	70673970	1	341C	BEARING	CUSCINETTO
2	79051207	8	40V	SCREW	VITE
3	70935974	1	187A	SNAP RING	ANELLO ELASTICO
4	70927747	1	45A	RING	ANELLO
5	70928720	2	51A	LOCKRING	ANELLO DI SICUREZZA
6	14458580	1	158G	O-RING 2,62x35,17	GUARNIZIONE O-R 2,62x36,17
7	71004835	10	44V	SCREW AND WASHER ASSY	VITE CON ROSETTA
8	71005536	1	158G	O-RING	GUARNIZIONE O-R
9	71008468	24	44V	SCREW AND WASHER ASSY	VITE CON ROSETTA
10	73117963	1	50T	PLUG	TAPPO
11	73118063	1	20D	DEFLECTOR	DEFLETTORE
12	73118064	1	123G	SEAL ASSY	GUARNIZIONE TENUTA FRONTALE
13	73118065	1	50I	GEAR	INGRANAGGIO
14	73118066	1	75D	SPACER	DISTANZIALE
15	73118067	1	158G	O-RING	GUARNIZIONE O-R
16	73118068	4	110P	PLAQUE	PIASTRINA
17	73118069	1	60G	IMPELLER	GIRANTE
18	73118072	1	341C	BEARING	CUSCINETTO
19	73118073	1	51A	LOCKRING	ANELLO DI SICUREZZA
20	73118074	1	131R	WASHER	ROSETTA
21	73132674	1	265C	COVER	COPERCHIO
22	73118173	1	75M	DIAPHRAGM	MEMBRANA
23	73118174	2	75M	DIAPHRAGM	MEMBRANA
24	73118175	1	45A	RING	ANELLO
25	79051688	1	135M	HUB	MOZZO
26	71004797	12	131R	WASHER	ROSETTA
27	71004795	12	40V	SCREW	VITE

79057724
 TRANSMISSION - CAMBIO DI VELOCITA' - BOITE DE VITESSES - WECHSELGETRIEBE - CAMBIO DE VELOCIDADES

9

B2.01/A 1
 N.T.R. 191 - 20.02.1990
 604.01.081.04

Q5

45A

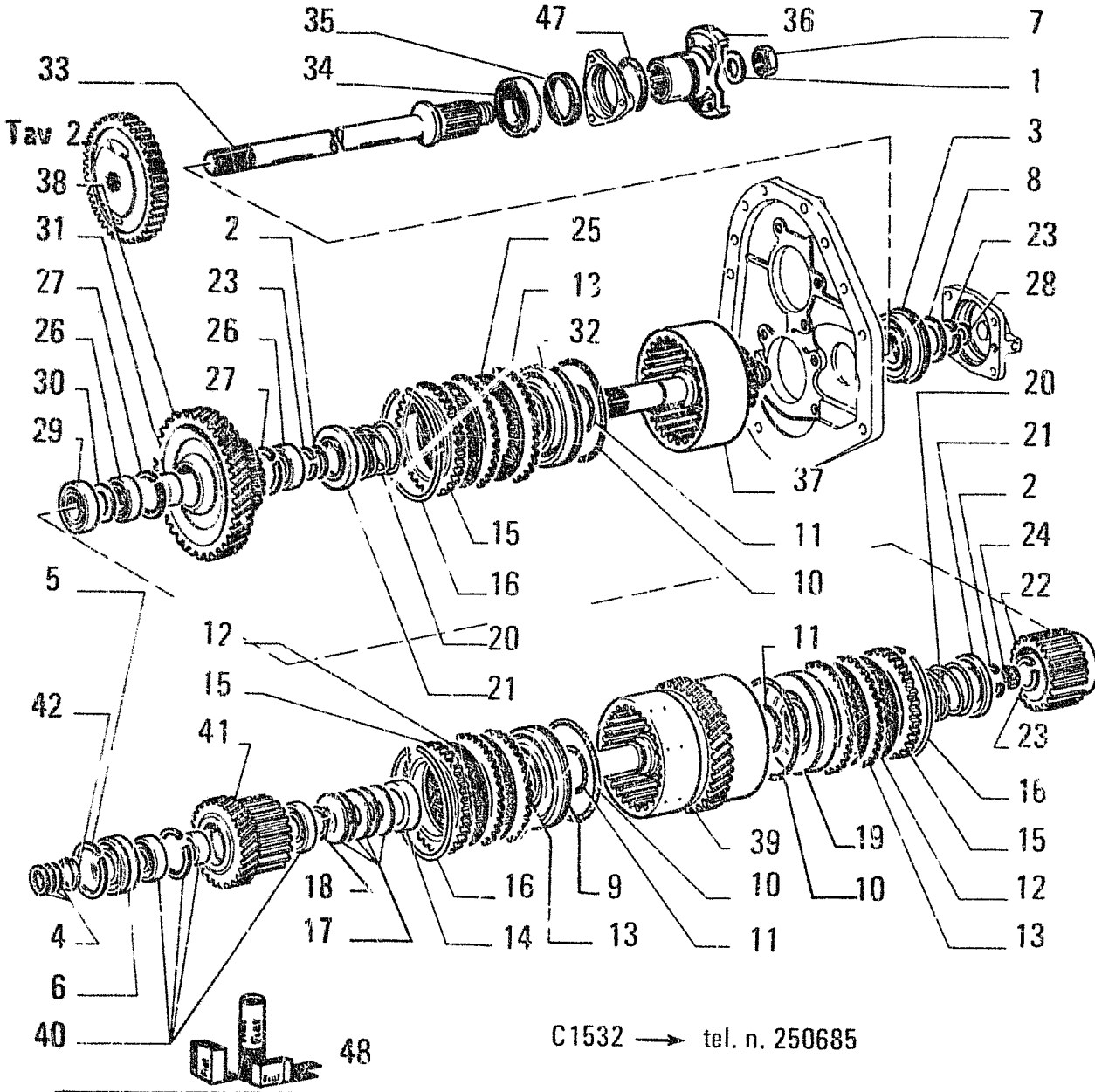

FIATALLIS FD7

ITEM	PART NUMBER	QTY	TRANS CODE	DESCRIPTION	DESCRIZIONE
27	73118135	2	51A	LOCKRING	ANELLO DI SICUREZZA
28	73118136	1	45A	RING	ANELLO
29	73118137	1	341C	BEARING	CUSCINETTO
30	73118138	1	75D	SPACER	DISTANZIALE
31	73118139	1	75D	SPACER	DISTANZIALE
32	73118236	1	130P	PLUNGER	PISTONCINO
33	79030218	1	16A	SHAFT	ALBERO
34	79030219	1	341C	BEARING	CUSCINETTO
35	79030222	1	123G	SEA/ ASSY	GUARNIZIONE TENUTA FRONTALE
36	79030223	1	70F	FLANGE	FLANGIA
37	79030228	1	16A	SHAFT	ALBERO
38	79030229	1	50I	GEAR	INGRANAGGIO
39	79030233	1	16A	SHAFT	ALBERO
40	79030234	1	341C	BEARING	CUSCINETTO
41	79030235	1	50I	GEAR	INGRANAGGIO
42	79030236	1	45A	RING	ANELLO
	79030237	1	45A	RING	ANELLO
	79030238	1	45A	RING	ANELLO
	79030239	1	45A	RING	ANELLO
	79030240	1	45A	RING	ANELLO
47	79031008	1	158G	O-RING	GUARNIZIONE O-R
48	79055160	1	1K	KIT SEE PAGE 9	KIT VED. PAG.9

C1532 -> tel. n. 250685

79028189

TRANSMISSION - CAMBIO DI VELOCITA' - BOITE DE VITESSES - WECHSELGETRIEBE - CAMBIO DE VELOCIDADES

9

B2.01

7

N.T.R. 191 - 20.02.1990

604.01.081.04

Q6

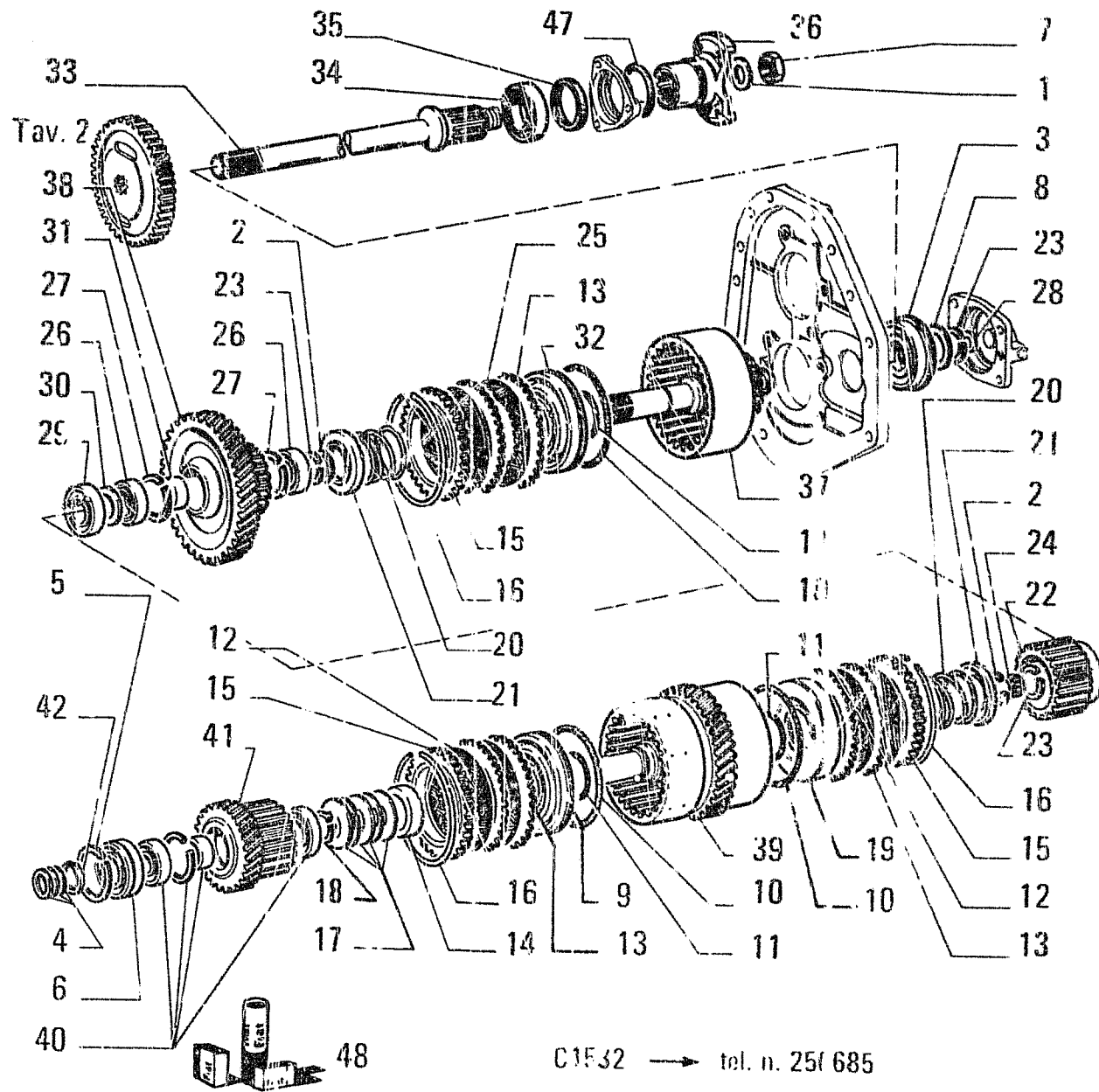

FIATALLIS FD7

B2.01 YAV. 7 PAG.1

ITEM	PART NUMBER	QTY	TRANS CODE	DESCRIPTION	DESCRIZIONE
1	70673871	1	131R	WASHER	ROSETTA
2	70926000	2	51A	LOCKRING	ANELLO DI SICUREZZA
3	71004777	1	341C	BEARING C1169	CUSCINETTO C1169
	73132784	1	341C	BEARING D1169	CUSCINETTO D1169
4	71004926	3	45A	RING	ANELLO
5	71004961	1	51A	LOCKRING	ANELLO DI SICUREZZA
6	71004962	1	341C	BEARING	CUSCINETTO
7	73109871	1	10D	NUT	DADO
8	73118058	1	131R	WASHER	ROSETTA
9	73118085	1	130F	PLUNGER	PISTONCINO
10	73118086	3	123/3	SEAL ASSY	GUARNIZIONE TENUTA FRONTALE
11	73118087	3	123/3	SEAL ASSY	GUARNIZIONE TENUTA FRONTALE
12	73118088	14	60D	DISC	DISCO
13	73118089	22	60D	DISC	DISCO
14	73118090	1	75D	SPACER	DISTANZIALE
15	73118091	3	60D	DISC	DISCO
16	73118092	3	45A	RING	ANELLO
17	73118093	5	100M	SPRING	MOLLA
18	73118094	1	51A	LOCKRING	ANELLO DI SICUREZZA
19	73118106	1	130P	PLUNGER	PISTONCINO
20	73118107	2	100M	SPRING	MOLLA
21	73118108	2	60S	CUP	SCODELLINO
22	73118109	1	135M	HUB	MOZZO
23	73118110	3	51A	LOCKRING	ANELLO DI SICUREZZA
24	73118111	1	341C	BEARING	CUSCINETTO
25	73118133	8	60D	DISC	DISCO
26	73118134	2	341C	BEARING	CUSCINETTO

79028189

TRANSMISSION - CAMBIO DI VELOCITA' - BOITE DE VITESSES - WECHSELGETRIEBE - CAMBIO DE VELOCIDADES

9

B2.01

7

N.T.R. 191 - 20.02.1990

604.01 081.04

Q7

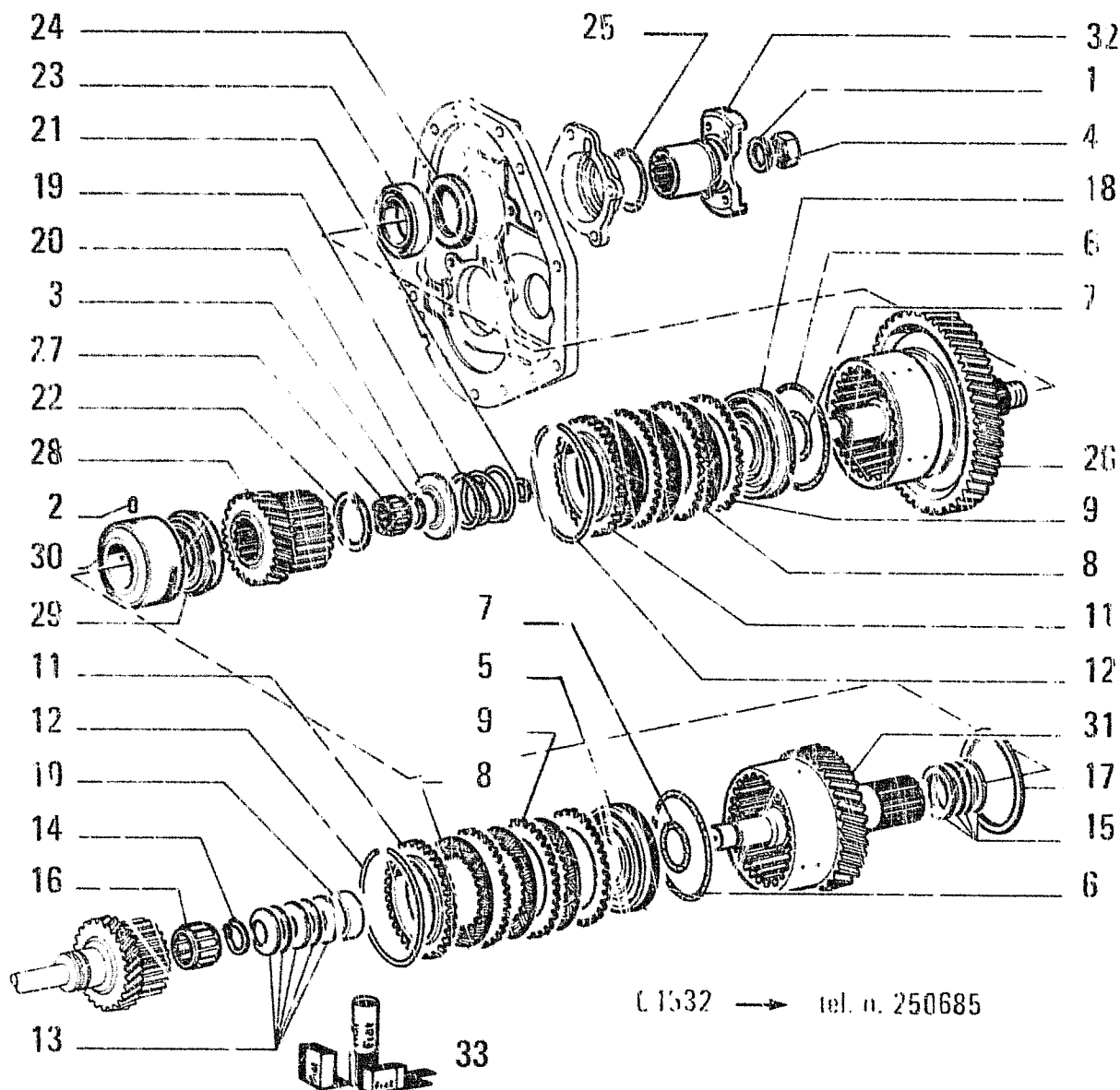

ITEM	PART NUMBER	QTY	TRANS CODE	DESCRIPTION	DESCRIZIONE
25	79030214	1	158G	O-RING C1171	GUARNIZIONE O-R C1171
26	79030225	1	16A	SHAFT	ALBERO
27	79030226	1	341C	BEARING	CUSCINETTO
28	79030227	1	5C	GEAR	INGRANAGGIO
29	79030230	1	341C	BEARING	CUSCINETTO
30	79030231	1	135M	HUB	MOZZO
31	79030232	1	16A	SHAFT	ALBERO
32	79031240	1	70F	FLANGE	FLANGIA
33	79055160	1	1K	KIT SEE PAGE 9	KIT VED. PAG.9

79028189
 TRANSMISSION - CAMBIO DI VELOCITA' - BOITE DE VITESSES - WECHSELGETRIEBE - CAMBIO DE VELOCIDADES

9
 B2.01 6
 N.T.R. 191 - 20.02.1990
 604.01.081.04



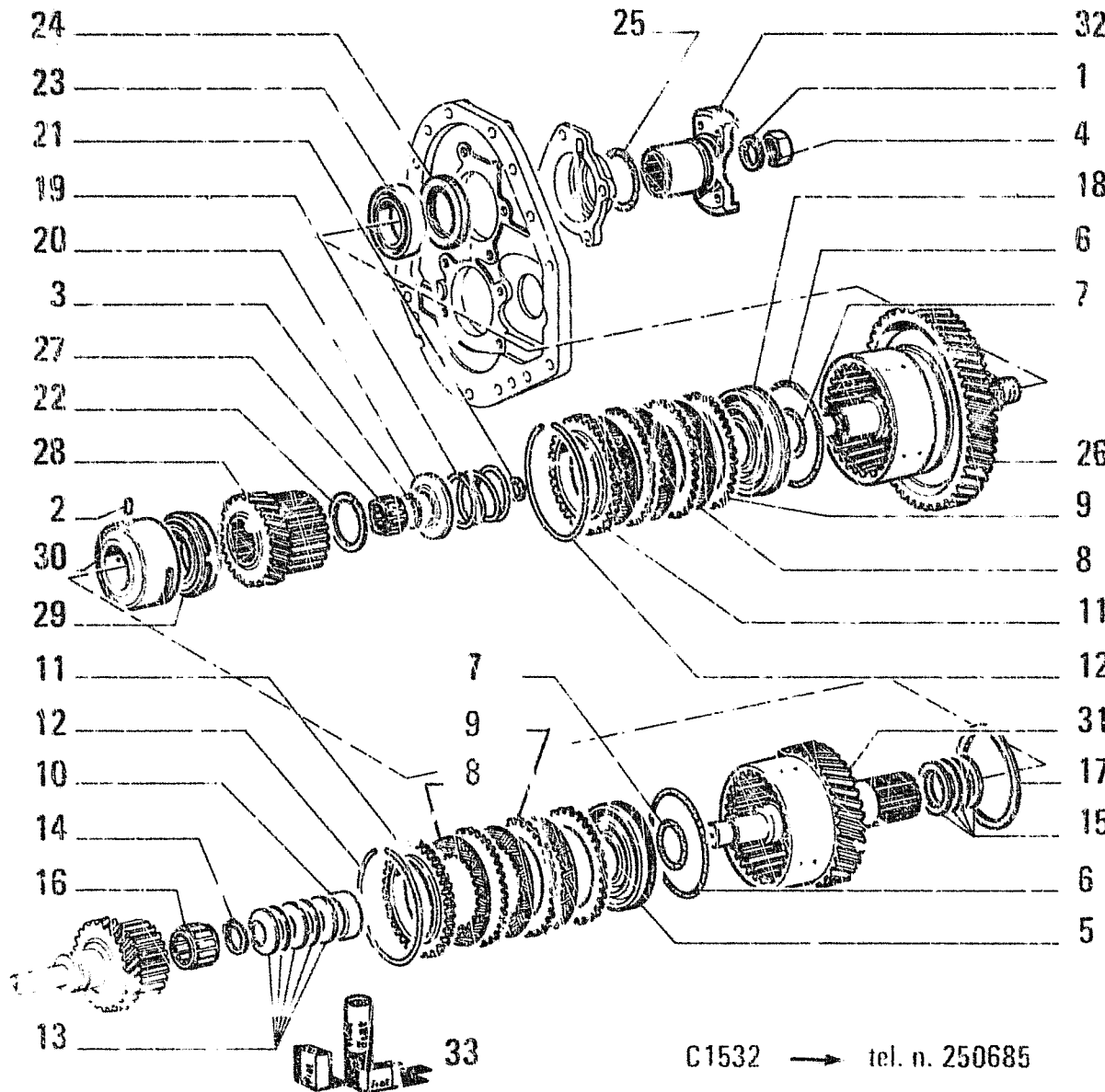

C1532 → tel. n. 250685

ITEM	PART NUMBER	QTY	TRANS CODE	DESCRIPTION	DESCRIZIONE
1	70673871	1	131R	WASHER	ROSETTA
2	14603470	1	80P	PIN 6x16 D1171	PERNO 6x16 D1171
	70919347	1	80P	PIN C1171	PERNO C1171
3	70926000	1	51A	LOCKRING	ANELLO DI SICUREZZA
4	73109871	1	10D	NUT	DAPO
5	73118085	1	130P	PLUNGER	PISTONCINO
6	73118086	2	123G	SEAL ASSY	GUARNIZIONE TENUTA FRONTALE
7	73118087	2	123G	SEAL ASSY	GUARNIZIONE TENUTA FRONTALE
8	73118088	14	60D	DISC	DISCO
9	73118089	14	60D	DISC	DISCO
10	73118090	1	75D	SPACER	DISTANZIALE
11	73118091	2	60D	DISC	DISCO
12	73118092	2	45A	RING	ANELLO
13	73118093	5	100M	SPRING	MOLLA
14	73118094	1	51A	LOCKRING	ANELLO DI SICUREZZA
15	73118096	4	45A	RING	ANELLO
16	73118097	1	341C	BEARING	CUSCINETTO
17	73118098	1	51A	LOCKRING	ANELLO DI SICUREZZA
18	73118106	1	130P	PLUNGER	PISTONCINO
19	73118107	1	100M	SPRING	MOLLA
20	73118108	1	60G	CUP	SCODELLINO
21	73118136	1	45A	RING	ANELLO
22	73118369	1	51A	LOCKRING	ANELLO DI SICUREZZA
23	79030209	1	341C	BEARING	CUSCINETTO
24	79030210	1	123G	SEAL ASSY	GUARNIZIONE TENUTA FRONTALE
25	14463880	1	155G	O-RING 3,53x4,52 D1171	GUARNIZIONE O-R 3,53x34,52 D1171

79028129

TRANSMISSION - CAMBIO DI VELOCITA' - BOITE JE VITESSES - WECHSELGETRIEBE - CAMBIO DE VELOCIDADES

9

B2.01

6

IV.T.R. 191 - 20.02.1990

604.01.081.04

C1532 → tel. n. 250685

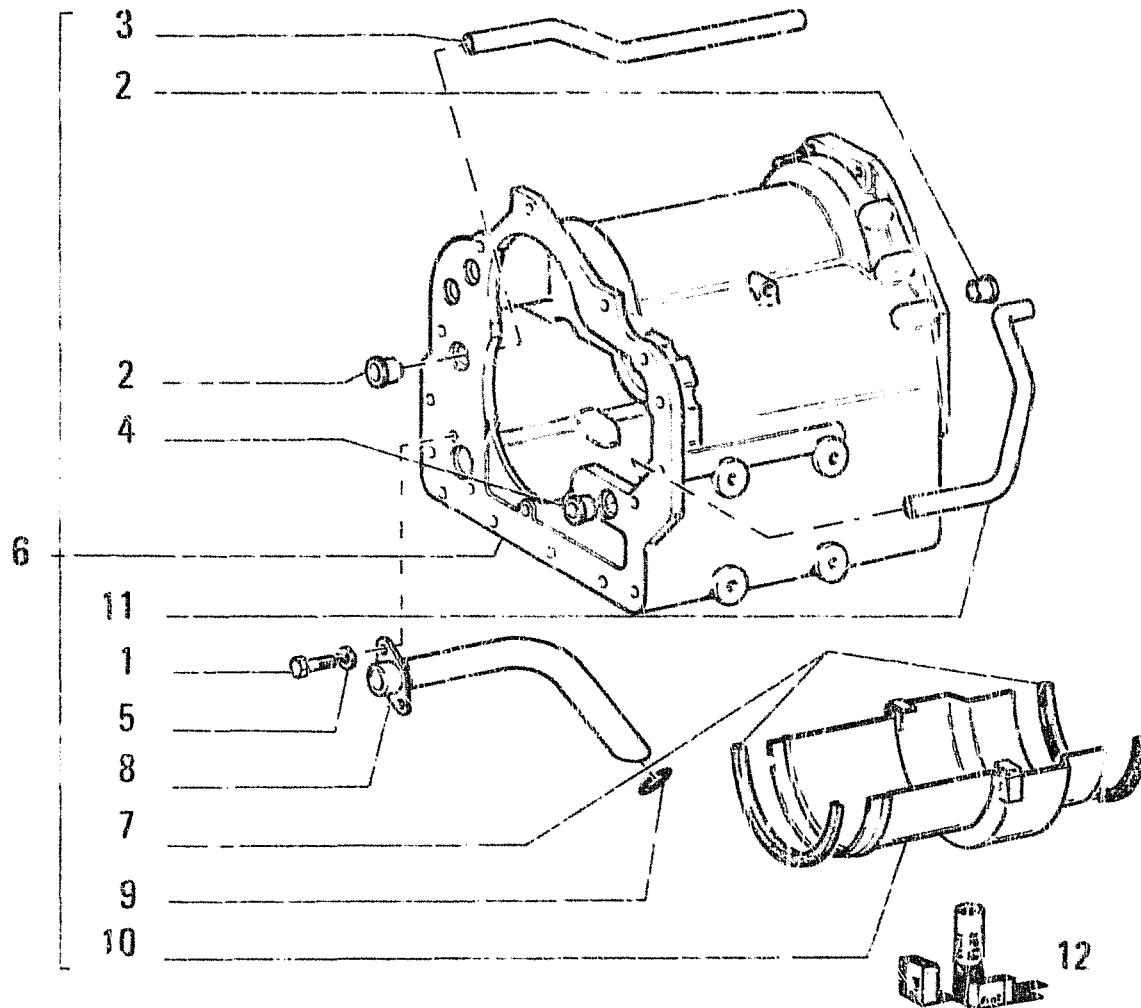

ITEM	PART NUMBER	QTY	TRANS CODE	DESCRIPTION	DESCRIZIONE
1	70927612	2	40V	SCREW	VITE
2	71004820	2	135M	HUB	MOZZO
3	73118043	1	193T	TUBE	TUBO RIGIDO
4	73118044	1	135M	HUB	MOZZO
5	10571779	2	131R	WASHER 8,1x2 D1171	ROSETTA 8,1x2 D1171
	74052780	2	131R	WASHER C1171	ROSETTA C1171
6	79030265	1	35S	CASE - ASSEMBLY	SCATOLA - COMPLETO
7	79030268	2	123G	SEAL ASSY	GUARNIZIONE TENUTA FRONTALE
8	79030269	1	193T	TUBE	TUBO RIGIDO
9	79030270	1	158G	O-RING	GUARNIZIONE O-R
10	79030271	1	20D	DEFLECTOR	DEFLETTORE
11	79030277	1	193T	TUBE	TUBO RIGIDO
12	79055160	1	1K	KIT SEE PAGE 9	KIT VED PAG.9

79028189

TRANSMISSION - CAMBIO DI VELOCITA' - BOITE DE VITESSES - WECHSELGETRIEBE - CAMBIO DE VELOCIDADES

9

B2.01

5

N.T.R. 191 - 20.02.1990

604.01.081.04

Q10

C1532 → tel. n 250685

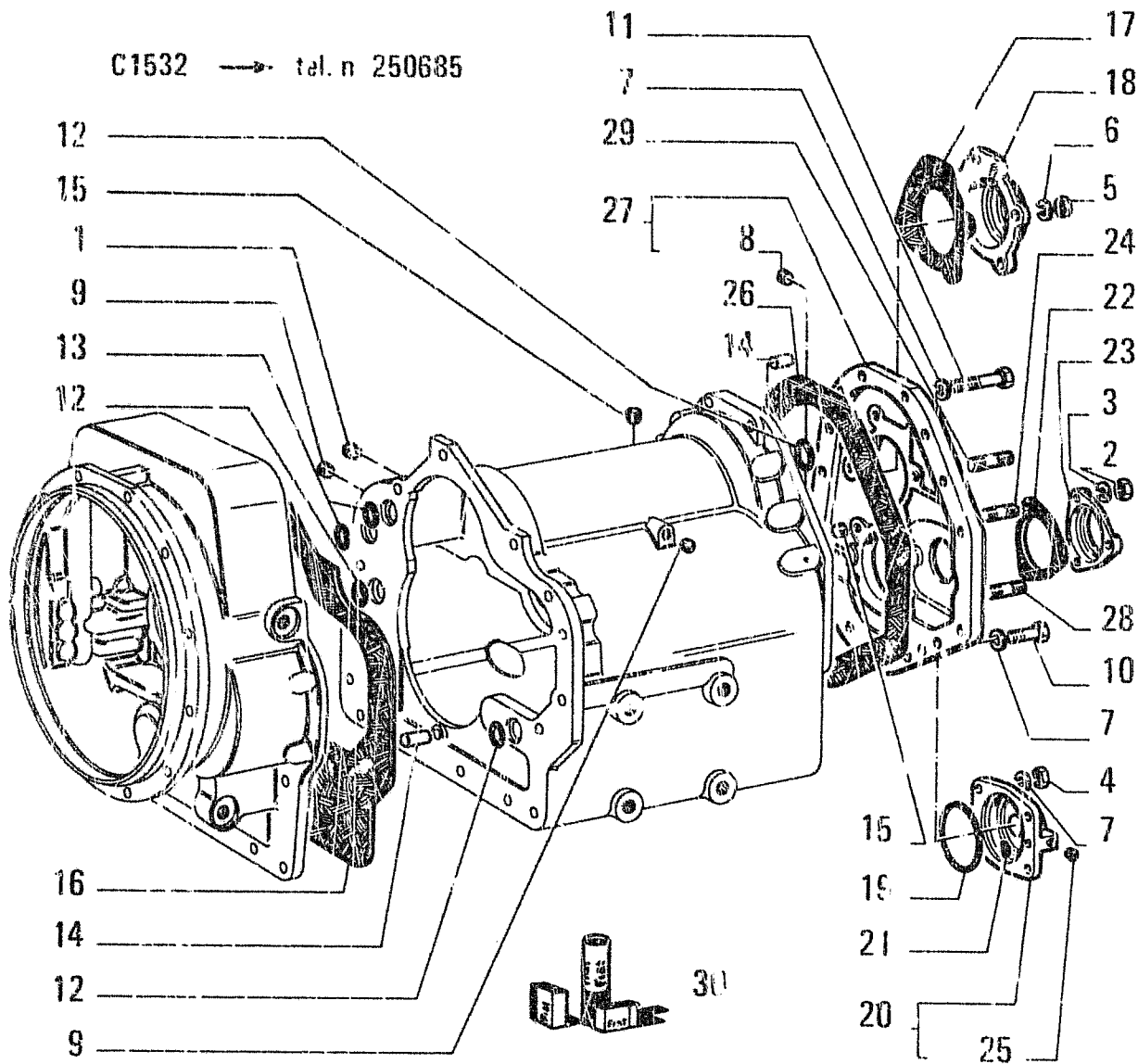

ITEM	PART NUMBER	QTY	TRANS CODE	DESCRIPTION	DESCRIZIONE
23	79030221	1	265C	COVER	COPERCHIO
24	79030224	3	210P	STUD	PRIGIONIERO
25	79030241	1	50T	PLUG	TAPPO
26	79030266	1	123G	SEAL ASSY	GUARNIZIONE TENUTA FRONTALE
27	79030267	1	265C	COVER - ASSEMBLY	COPERCHIO - COMPLETO
28	79031001	4	210P	STUD	PRIGIONIERO
29	79031002	4	210P	STUD	PRIGIONIERO
30	79055160	1	1K	KIT SEE PAGE 9	KIT VED. PAG.9

79028189

9

TRANSMISSION - CAMBIO DI VELOCITA' - BOITE DE VITESSES - WECHSELGETRIEBE -- CAMBIO DE VELOCIDADES

B2.01

4

N.T.R. 191 - 20.02.1990

604.01.081.04

C1532 → tel. n. 250685

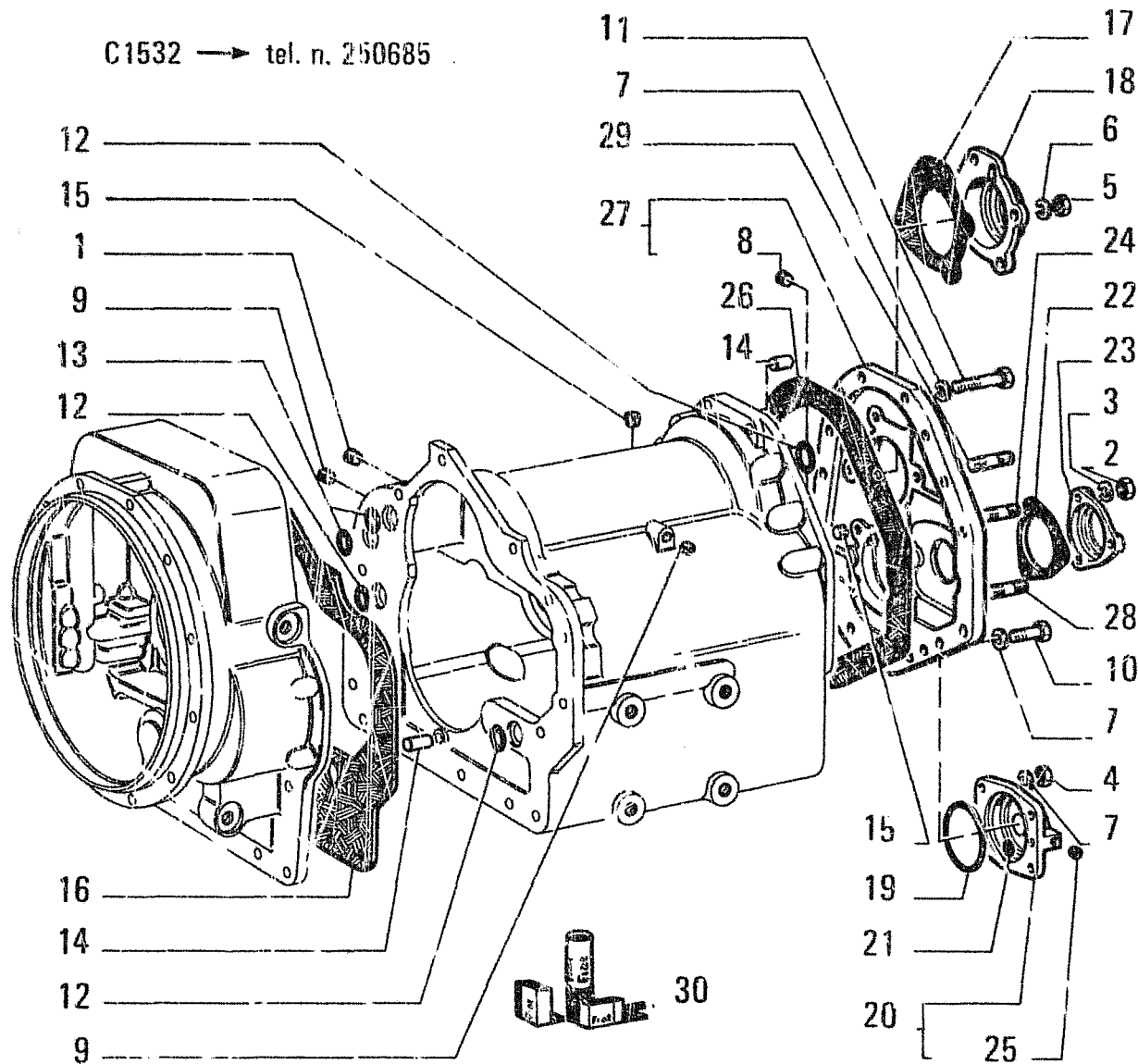

FRONTALIS FD7

B2.01 "AV. 4" PAG.1

ITEM	PART NUMBER	QTY	TRANS CODE	DESCRIPTION	DESCRIZIONE
1	70673860	1	50T	PLUG	TAPPO
2	70910123	3	10D	NUT	DADO
3	70273916	3	131R	WASHER D1171	ROSETTA D1171
	70910287	3	131R	WASHER C1171	ROSETTA C1171
4	70910986	4	10D	NUT	DADO
5	70911331	4	10D	NUT	DADO
6	70912433	4	131R	WASHER	ROSETTA
7	70914678	19	131R	WASHER	ROSETTA
8	70917673	1	50T	PLUG	TAPPO
9	70918850	2	50T	PLUG	TAPPO
10	70921569	6	40V	SCREW	VITE
11	70927583	9	40V	SCREW	VITE
12	14462980	3	158G	O-RING 3,53x20,22 D1171	GUARNIZIONE (O-R 3,53x20,22 D1171
	70929217	3	158G	O-RING C1171	GUARNIZIONE O-R C1171
13	14467180	2	158G	O-RING 2,62x13,94 C1171	GUARNIZIONE O-R 2,62x13,94 D1171
	70933875	2	158G	O-RING C1171	GUARNIZIONE O-R C1171
14	71004838	3	80P	PIN	PERNO
15	73066768	2	50T	PLUG	TAPPO
16	73118040	1	123G	SEAL ASSY	GUARNIZIONE TENUTA FRONTALE
17	79030211	1	123G	SEAL ASSY	GUARNIZIONE TENUTA FRONTALE
18	79030212	1	265C	COVER	COPERCHIO
19	79030215	1	158G	O-RING	GUARNIZIONE O-R
20	79030216	1	265C	COVER - ASSEMBLY	COPERCHIO - COMPLETO
21	79030217	1	158G	O-RING	GUARNIZIONE O-R
22	79030220	1	123G	SEAL ASSY	GUARNIZIONE TENUTA FRONTALE

79028189

9

TRANSMISSION - CAMBIO DI VELOCITA' - BOITE DE VITESSES -- WECHSELGETRIEBE - CAMBIO DE VELOCIDADES

B2.01

4

N.T.R. 191 - 20.02.1990

604.01.081.04

Q12

C1532 → tel. n. 250625

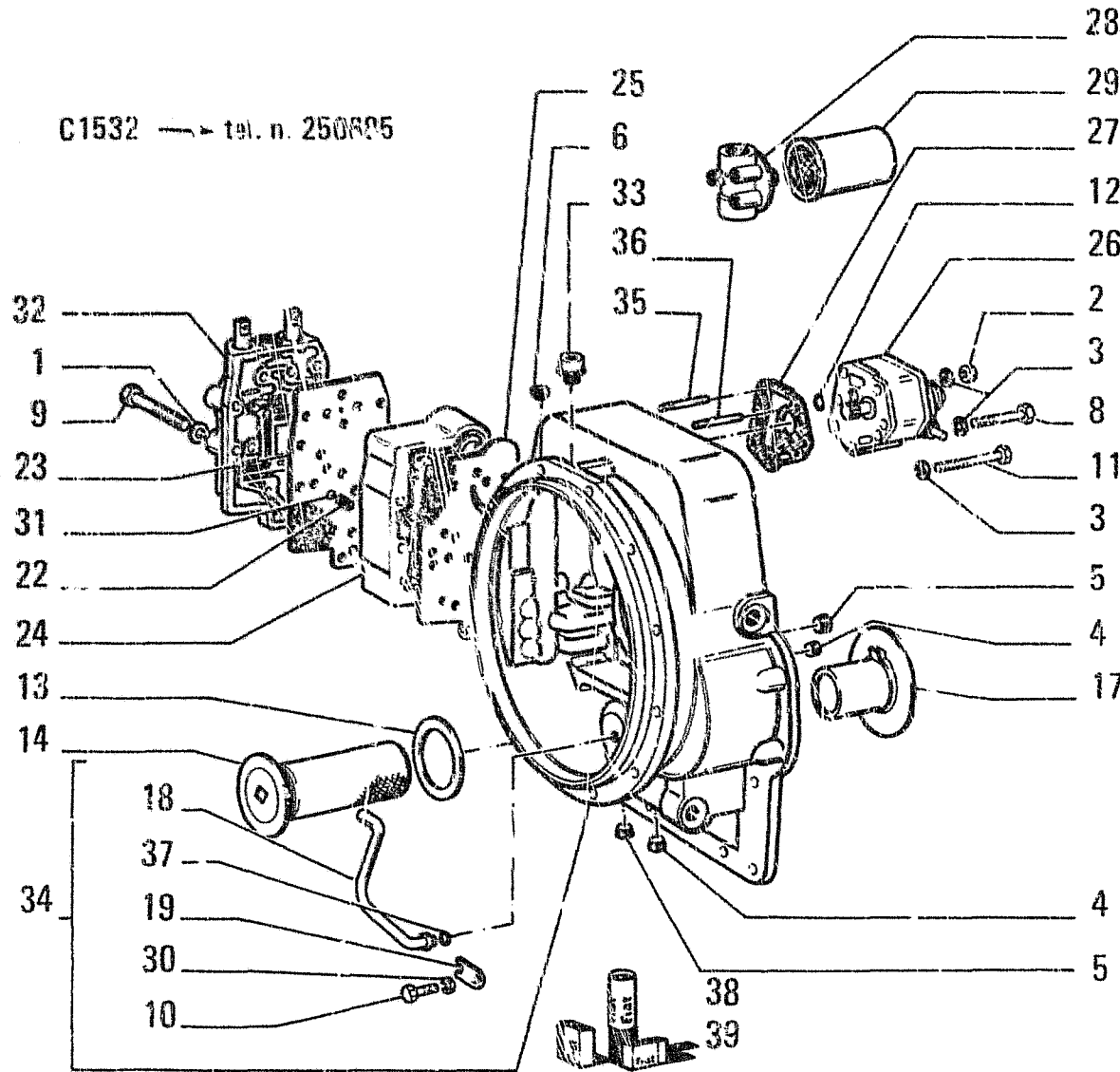

ITEM	PART NUMBER	QTY	TRANS CODE	DESCRIPTION	DESCRIZIONE
27	73118167	1	123G	SEAL ASSY	GUARNIZIONE TENUTA FRONTALE
28	73118170	1	300S	SUPPORT	SUPPORTO
29	73118171	1	65F	FILTER	FILTRO
30	10571779	1	131R	WASHER 8,1x2 D1171	ROSETTA 8,1x2 D1171
	74052780	1	31R	WASHER C1171	ROSETTA C1171
31	70905350	2	10S	BALL D1171	SFERA D1171
	74055100	2	14JS	BALL C1171	SFERA C1171
32	79030262	1	83D	CONTROL VALVE - ASSEMBLY SEE SGR. B2.33	DISTRIBUTORE - COMPLETO VEDERE SGR. B2.33
33	79030263	1	50T	PLUG	TAPPO
34	79030264	1	35S	CASE - ASSEMBLY	SCATOLA - COMPLETO
35	79030999	1	210P	STUD	PRIGIONIERO
36	79031000	1	210P	STUD	PRIGIONIERO
37	79031003	1	158G	O-RING	GUARNIZIONE O-R
38	79055159	1	1K	KIT SEE PAGE 9	KIT VED. PAG.9
39	79055160	1	1K	KIT SEE PAGE 9	KIT VED. PAG.9

79028189

TRANSMISSION - CAMBIO DI VELOCITA' - BOITE DE VITESSES - WECHSELGETRIEBE -
CAMBIO DE VELOCIDADES

9

B2.01

3

N.T.R. 191 - 20.02.1990

604.01.081.04

Q13

C1532 → tel. n. 250685

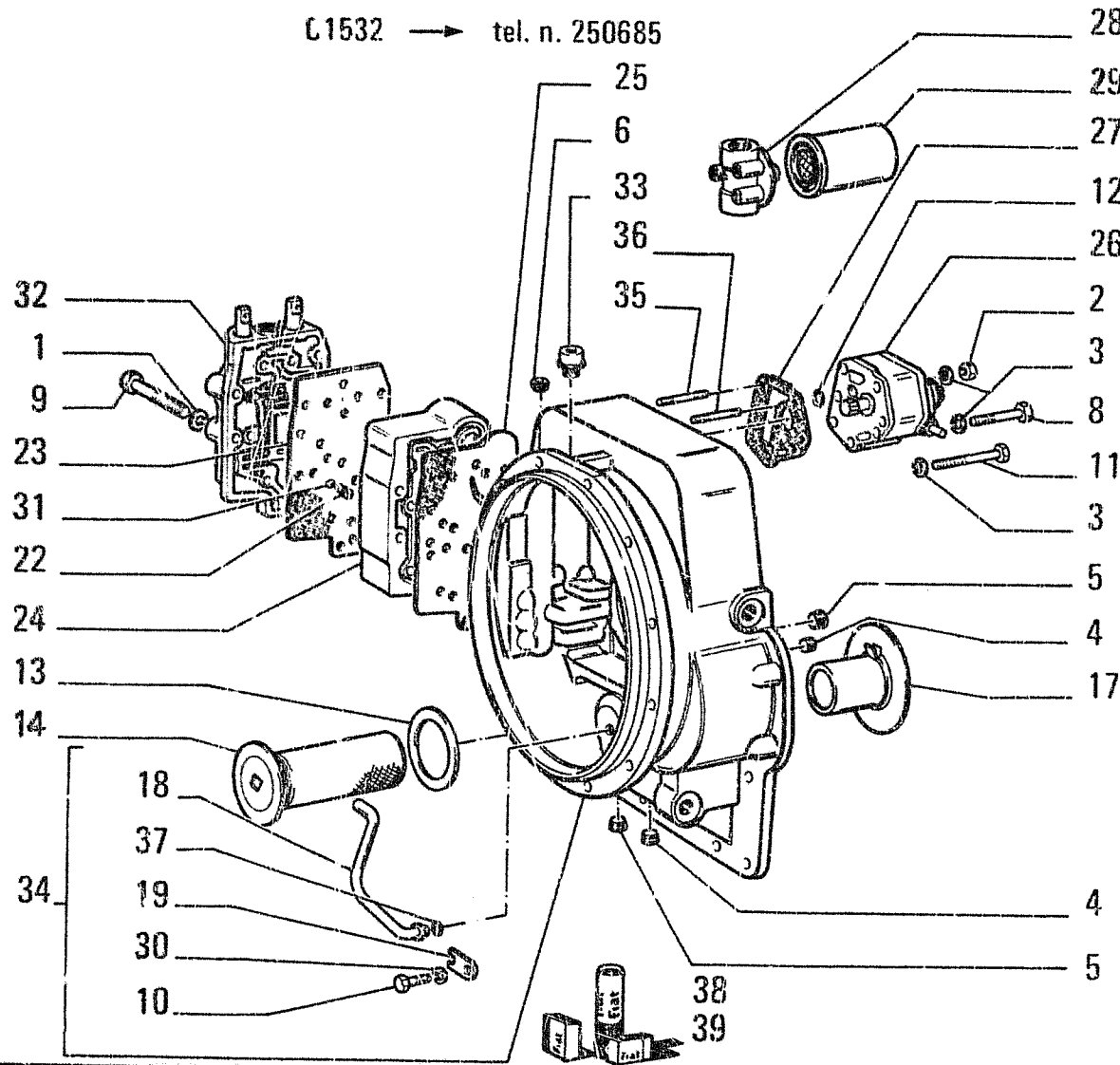

ITEM	PART NUMBER	QTY	TRANS CODE	DESCRIPTION	DESCRIZIONE
1	8273916	9	131R	WASHER D1171	ROSETTA D1171
	70910287	9	131R	WASHER C1171	ROSETTA C1171
2	70910986	2	10D	NUT	DADO
3	70914678	5	131R	WASHER	ROSETTA
4	70917673	2	50T	PLUG	TAPPO
5	70917970	2	50T	PLUG	TAPPO
6	70918850	1	50T	PLUG	TAPPO
8	70925821	2	40V	SCREW	VITE
9	70927536	9	40V	SCREW	VITE
10	70927612	1	40V	SCREW	VITE
11	70928527	1	40V	SCREW	VITE
12	14457180	1	158G	O-RING 2,62x13,94 D1171	GUARNIZIONE O-R 2,62x13,94 D1171
	70933875	1	158G	O-RING C1171	GUARNIZIONE O-R C1171
13	71004848	1	123G	SEAL ASSY	GUARNIZIONE TENUTA FRONTALE
14	71004849	1	65F	FILTER	FILTRO
17	73118039	1	135M	HUB	MOZZO
18	73118053	1	193T	TUBE	TUBO RIGIDO
19	73118054	1	45F	CLIP	FERMAGLIO
22	73118121	2	100M	SPRING	MOLLA
23	73118122	1	123G	SEAL ASSY C2911	GUARNIZIONE TENUTA FRONTALE C2911
	79086375	1	122C	SEAL D2911	GUARNIZIONE D2911
24	73118123	1	10V	VALVE - ASSEMBLY SEE SGR. B2.34	VALVOLA - COMPLETO VEDERE SGR. B2.34
25	73118124	1	123G	SEAL ASSY	GUARNIZIONE TENUTA FRONTALE
26	73118166	1	155P	PUMP	POMPA

79028189

TRANSMISSION - CAMBIO DI VELOCITA' - BOITE DE VITESSES - WECHSELGETRIEBE - CAMBIO DE VELOCIDADES

9

B2.01

3

N.T.R. 191 - 20.02.1990

604.01.081.04

Q14

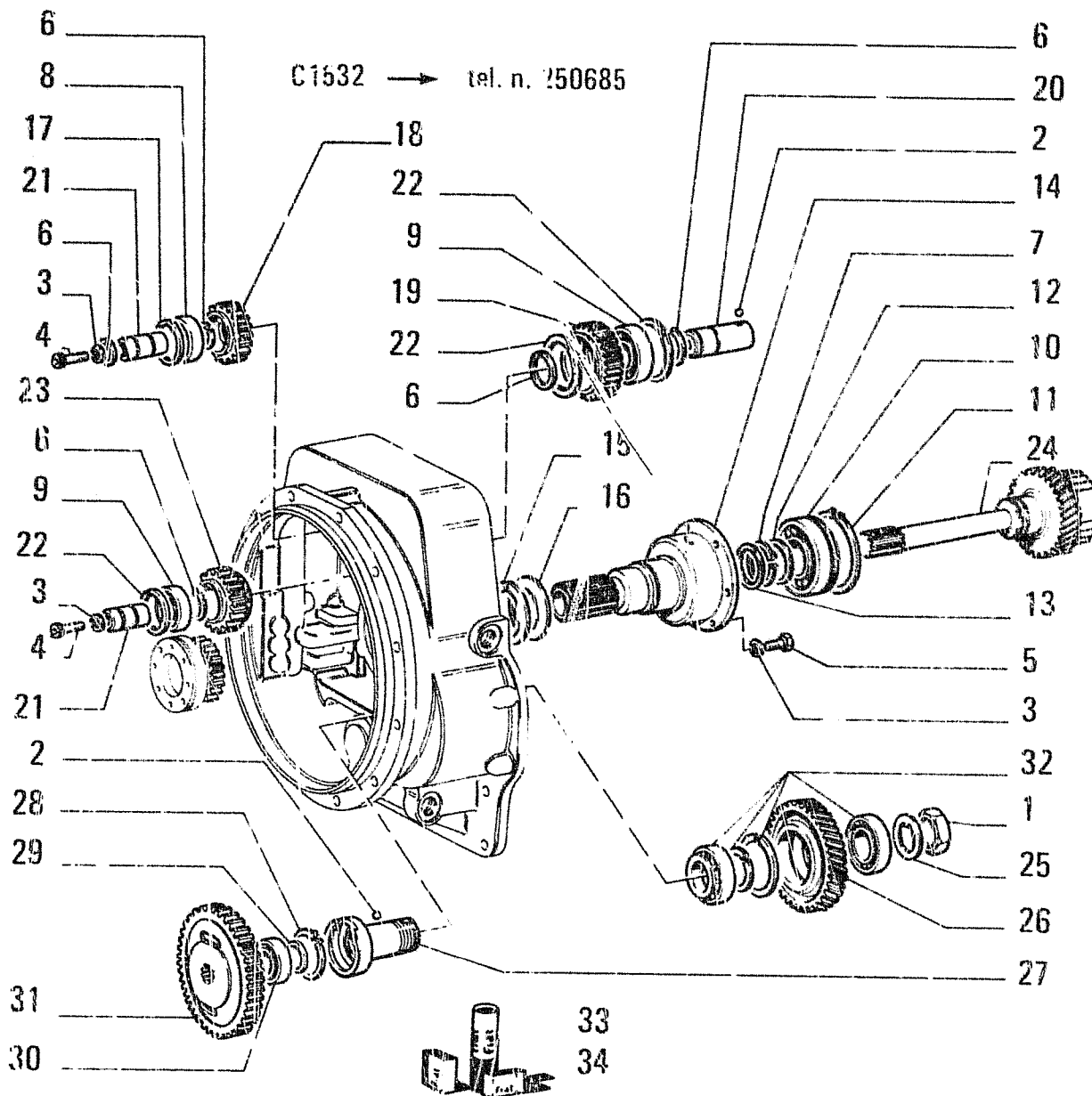

FIATALLIS FD7

QTY	PART NUMBER	TRANS CODE	DESCRIPTION	DESCRIZIONE
1	79030246	16A	SHAFT	ALBERO
2	79030247	131R	WASHER	ROSETTA
1	79030248	50I	GEAR	INGRANAGGIO
1	79030249	16A	SHAFT	ALBERO
1	79030250	51A	LOCKRING	ANELLO DI SICUREZZA
1	79030251	45A	RING	ANELLO
1	79030252	341C	BEARING	CUSCINETTO
1	79030253	50I	GEAR	INGRANAGGIO
1	79030261	341C	BEARING	CUSCINETTO
1	79055159	1K	KIT SEE PAGE 9	KIT VED. PAG.9
1	79055160	1K	KIT SEE PAGE 9	KIT VED. PAG.9

79028189
 TRANSMISSION - CAMBIO DI VELOCITA' - BOITE DE VITESSES - WECHSELGETRIEBE - CAMBIO DE VELOCIDADES

9
 B2.01 2
 N.T.R 200 15.10.1990
 604.01.081 05

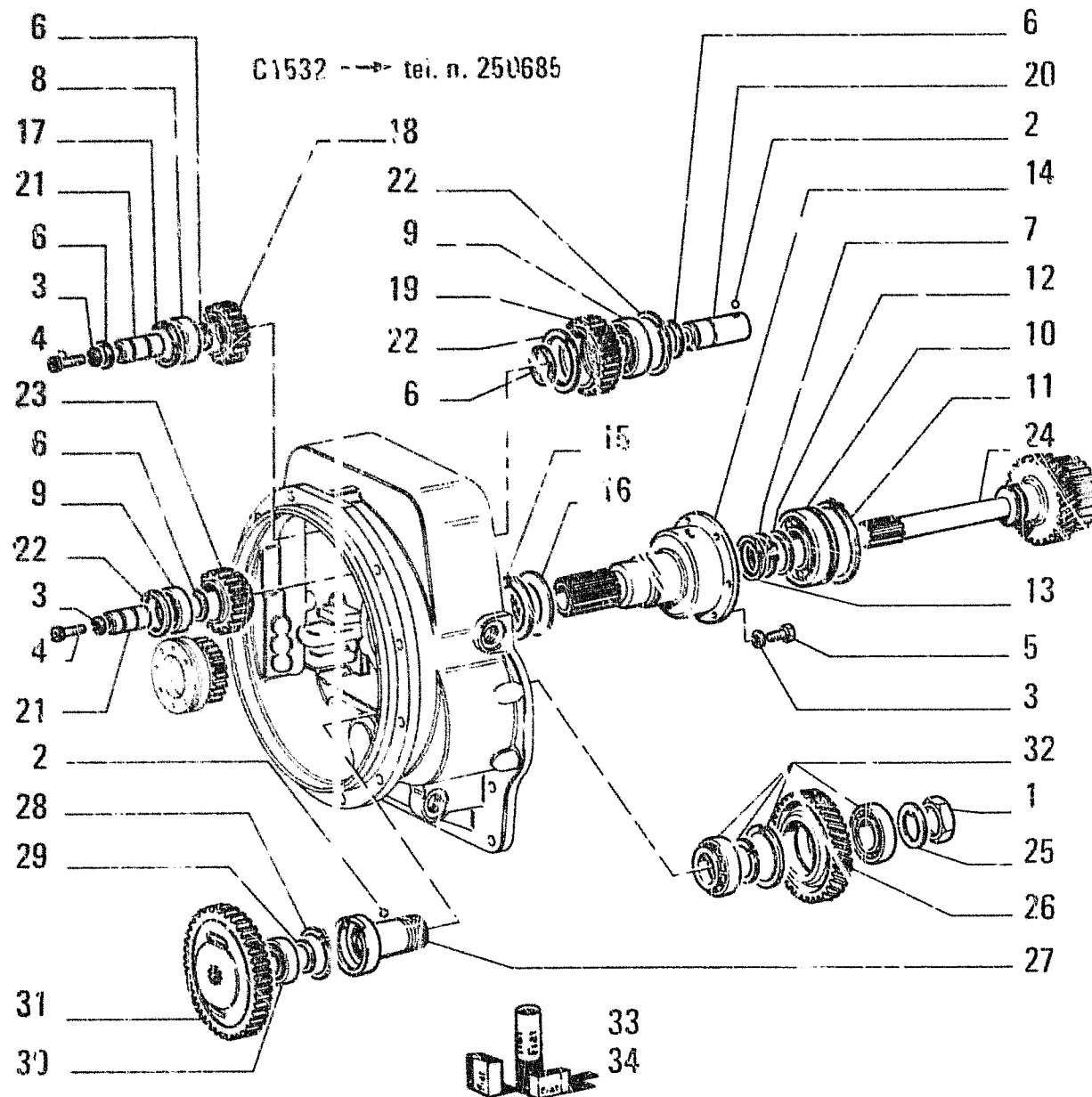

FIATALLIS F07

B2.01 TAV. 2 PAG.1

ITEM	PART NUMBER	QTY	TRANS CODE	DESCRIPTION	DESCRIZIONE
1	70059943	1	10D	NUT	DADO
2	70073856	2	140S	BALL	SFERA
3	8273916	0	131R	WASHER D1171	ROSETTA D1171
	70910287	1	131R	WASHER C1171	ROSETTA C1171
4	70921076	4	40V	SCREW	VITE
5	70922763	6	40V	SCREW	VITE
6	70929166	5	15A	RING	ANELLO
7	73116957	1	51A	LOCKRING	ANELLO DI SICUREZZA
8	73116959	1	341C	BEARING	CUSCINETTO
9	73116971	2	341C	BEARING	CUSCINETTO
10	73118056	1	341C	BEARING C1169	CUSCINETTO C1169
	73132932	1	341C	BEARING D1169	CUSCINETTO D1169
11	73118057	1	51A	LOCKRING	ANELLO DI SICUREZZA
12	73118058	2	131R	WASHER	ROSETTA
13	73118059	1	45A	RING	ANELLO
14	73118060	1	300S	SUPPORT C3213	SUPPORTO C3213
	79059927	1	300S	SUPPORT D3213	SUPPORTO D3213
15	73118061	1	45A	RING C2911	ANELLO C2911
	79064451	1	45A	RING D2911	ANELLO D2911
16	73118062	1	100M	SPRING	MOLLA
17	73118080	1	45A	RING	ANELLO
18	73118081	1	50I	GEAR	INGRANAGGIO
19	73118082	1	50I	GEAR	INGRANAGGIO
20	73118083	1	16A	SHAFT	ALBERO
21	73118262	2	300S	SUPPORT	SUPPORTO
22	73118320	3	45A	RING	ANELLO
23	79030242	1	50I	GEAR	INGRANAGGIO

79028189

TRANSMISSION - CAMBIO DI VELOCITA' - BOITE DE VITESSES - WECHSELGETRIEBE - CAMBIO DE VELOCIDADES

Q16

9

B2.01

2

N.T.R. 200 - 15.10.1990

604.01.081.05

C1537 → tel. n. 250685

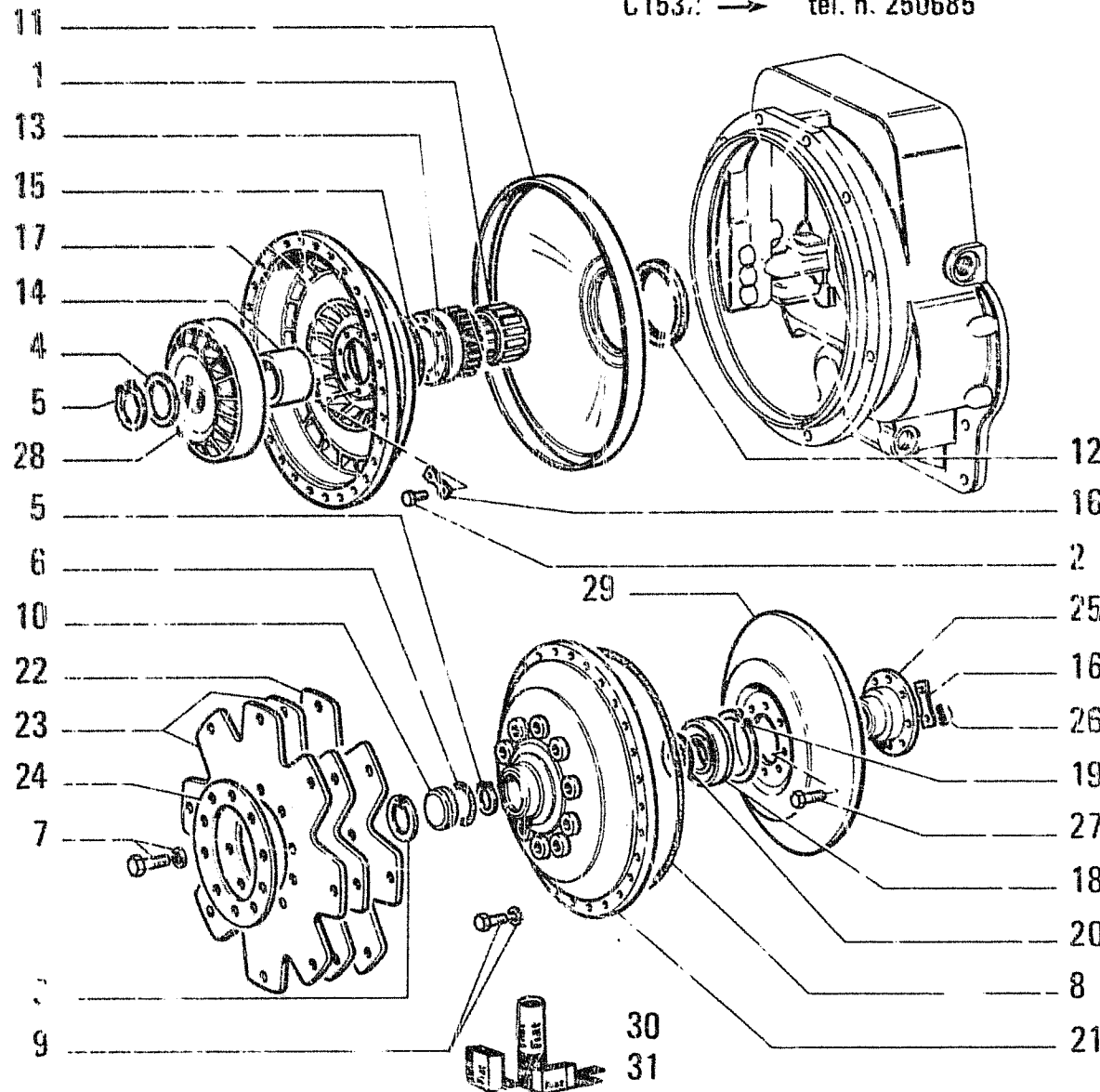

ITEM	PART NUMBER	QTY	TRANS CODE	DESCRIPTION	DESCRIZIONE
22	73118173	1	75M	DIAPHRAGM	MEMBRANA
23	73118174	2	75M	DIAPHRAGM	MEMBRANA
24	73118175	1	45A	RING	ANELLO
25	79030255	1	135M	HUB	MOZZO
26	79030256	8	10D	NUT	CAPO
27	79030257	8	40V	SCREW	VITE
28	79031238	1	271S	STATOR	STATORE
29	79031239	1	60G	IMPELLER	GIRANTE
30	79055159	1	1K	KIT SEE PAGE 9	KIT VED. PAG.9
31	79055160	1	1K	KIT SEE PAGE 9	KIT VED. PAG.9

79028189

9

TRANSMISSION - CAMBIO DI VELOCITA' - BOITE DE VITESSES - WECHSELGETRIEBE - CAMBIO DE VELOCIDADES

B2 01

1

N.T.R. 191 - 20.02.1990

604.01.081.04

Q17

B

MECHANICAL TRANSMISSION • CLUTCH • TRANSMISSION • TRANSMISSION SHAFT • AXLES
TRANSMISSIONE MECCANICA • FRIZIONE • CAMBIO • ALBERO DI TRANSMISSIONE • PONTI
TRANSMISSION MECANIQUE • EMBRAYAGE • BOITE DE VITESSES • ARBRE DE TRANSMISSION • PONTS
MECHANISCHE KRAFTÜBERTRAGUNG • KUPPLUNG • GETRIEBE • GELENKWELLE • ACHSEN
TRANSMISSION MECANICA • EMBRAGUE • CAMBIO • ARBOL DE TRANSMISSION • PUENTES

R1

D.1532 tel. n. 250986 →

C.I. 10 → tel. n. 250904

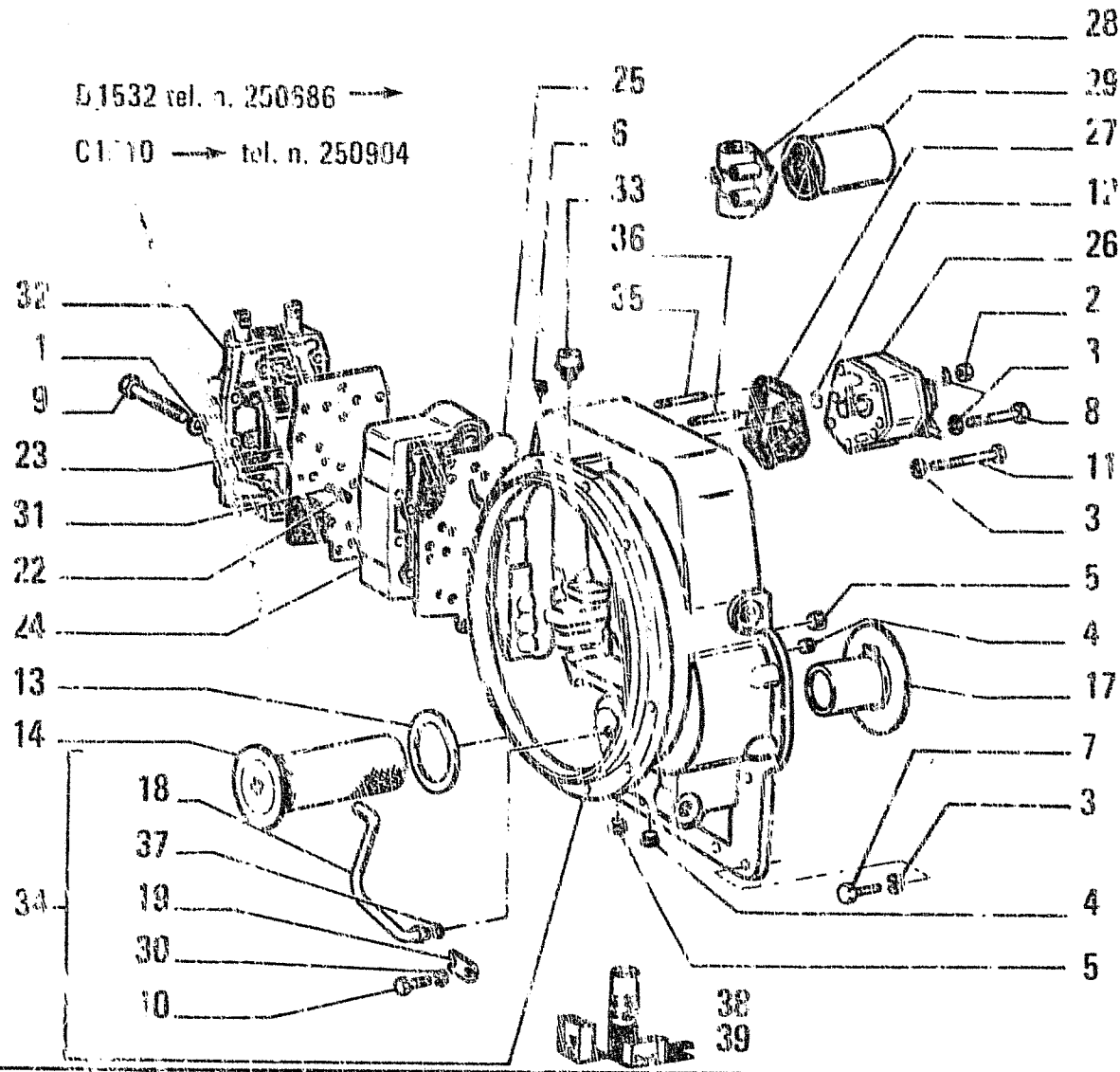

ITEM	PART NUMBER	QTY	TRANSM CODE	DESCRIPTION	DESCRIZIONE
1	10516079	9	170R	LOC. WASHER 10,2x2,5	ROSETTA EL. 10,2x2,5
2	70910926	2	OD	NUIT	DADO
3	709114673	21	131R	WASHER	ROSETTA
4	7313167	2	51T	PLUG	TAPPO
5	70917970	2	51T	PLUG	TAPPO
6	79051077	1	51T	PLUG	TAPPO
7	70921569	10	40V	SCREW	VITE
8	70925821	2	41A	SCREW	VITE
9	70927536	3	40V	SCREW	VITE
10	70927612	1	40V	SCREW	VITE
11	70928527	1	40V	SCREW	VITE
12	14457180	1	158G	O-RING 2,62x13,94	GUARNIZIONE O-R 2,62x13,94
13	71004848	1	123G	SEAL ASSY	GUARNIZIONE TENUTA FRONTALE
14	71004849	1	65F	FILTER	FILTRO
15	73118039	1	135M	HUB	MUZZO
16	73118053	1	193T	TUBE	TUBO RIGIDO
17	73118054	1	45F	CLIP	FER-MAGLIO
18	73118121	2	100M	SPRING	MOLLA
19	73118122	1	123G	SEAL ASSY C2911	GUARNIZIONE TENUTA FRONTALE C2911
20	79086375	1	122G	SEAL D2911	GUARNIZIONE D2911
21	79083010	1	10V	VALVE - ASSEMBLY SEE SGR. B2.34/A	VALVOLA - COMPLETO VEDFRE SGR. B2.34/A
22	73118124	1	123G	SEAL ASSY	GUARNIZIONE TENUTA FRONTALE
23	73118166	1	155P	PUMP	PCMPA
24	73118167	1	123G	SEAL ASSY	GUARNIZIONE TENUTA FRONTALE
25	73118170	1	20R	FITTING	RACCORDO

79057724

TRANSMISSION - CAMBIO DI VELOCITA' - BOITE DE VITESSES - WECHSELGETRIEBE - CAMBIO DE VELOCIDADES

9	B2.01/ A	3
N.T.F. 191 - 20.02.1990		
004 01.081.04		

D1532 tel. n. 25068t →

C1510 → tel. n. 250904

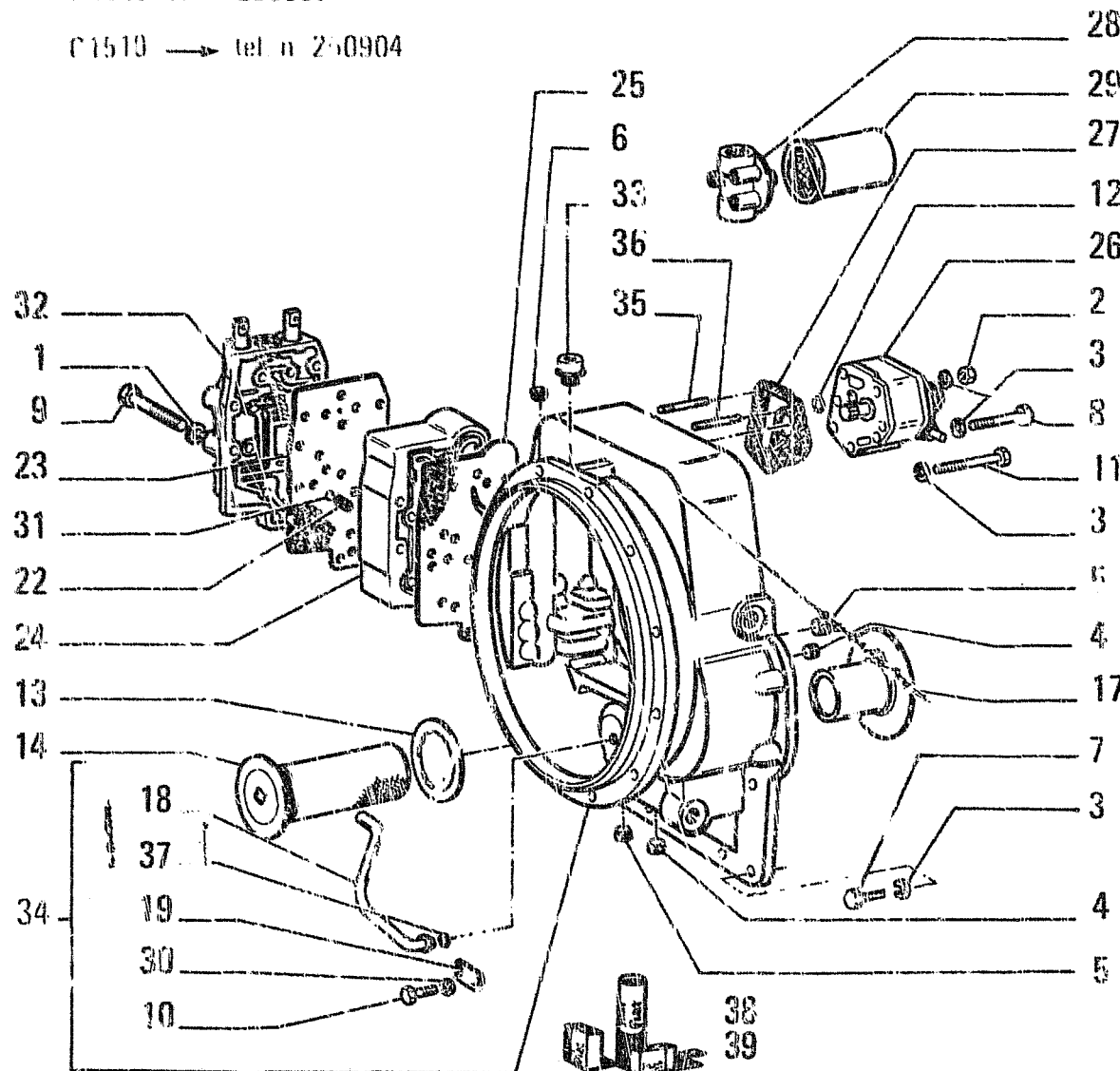

ITEM	PART NUMBER	QTY	TRANS CODE	DESCRIPTION	DESCRIZIONE
29	73118171	1	5F	FILTER	FILTRO
30	10571779	1	13 R	WASHER 8,1x2	ROSETTA 8,1x2
31	70905360	2	14G	BALL	SFERA
32	73060012	1	83C	CONTROL VALVE - ASSEMBLY SEE SGR. B2.33/A	DISTRIBUTORE - COMPLETO VEDERE SGR. B2.33/A
33	79030263	1	50T	PLUG	TAPPO
34	79034264	1	35S	CASE - ASSEMBLY	SCATOLA - COMPLETO
35	79030999	1	21CP	STUD	PRIGIONIERO
36	79031000	1	21CP	STUD	PRIGIONIERO
37	79031003	1	113G	O-RING	GUARNIZIONE O-R
38	79055159	1	1K	KIT SEE PAGE 9	KIT VED. PAG.9
39	79055160	1	1K	KIT SEE PAGE 9	KIT VED. PAG.9

7905/724

TRANSMISSION - CAMBIO DI VELOCITA' - BOITE DE VITESSES - WECHSELGETRIEBE
 CAMBIO DE VELOCIDADES

B2.01/ A 3
 N.T.R. 191 - 20.02.1990
 604.01.081.04

R3

D1532 tel. n. 250680

C1516 tel. n. 250504

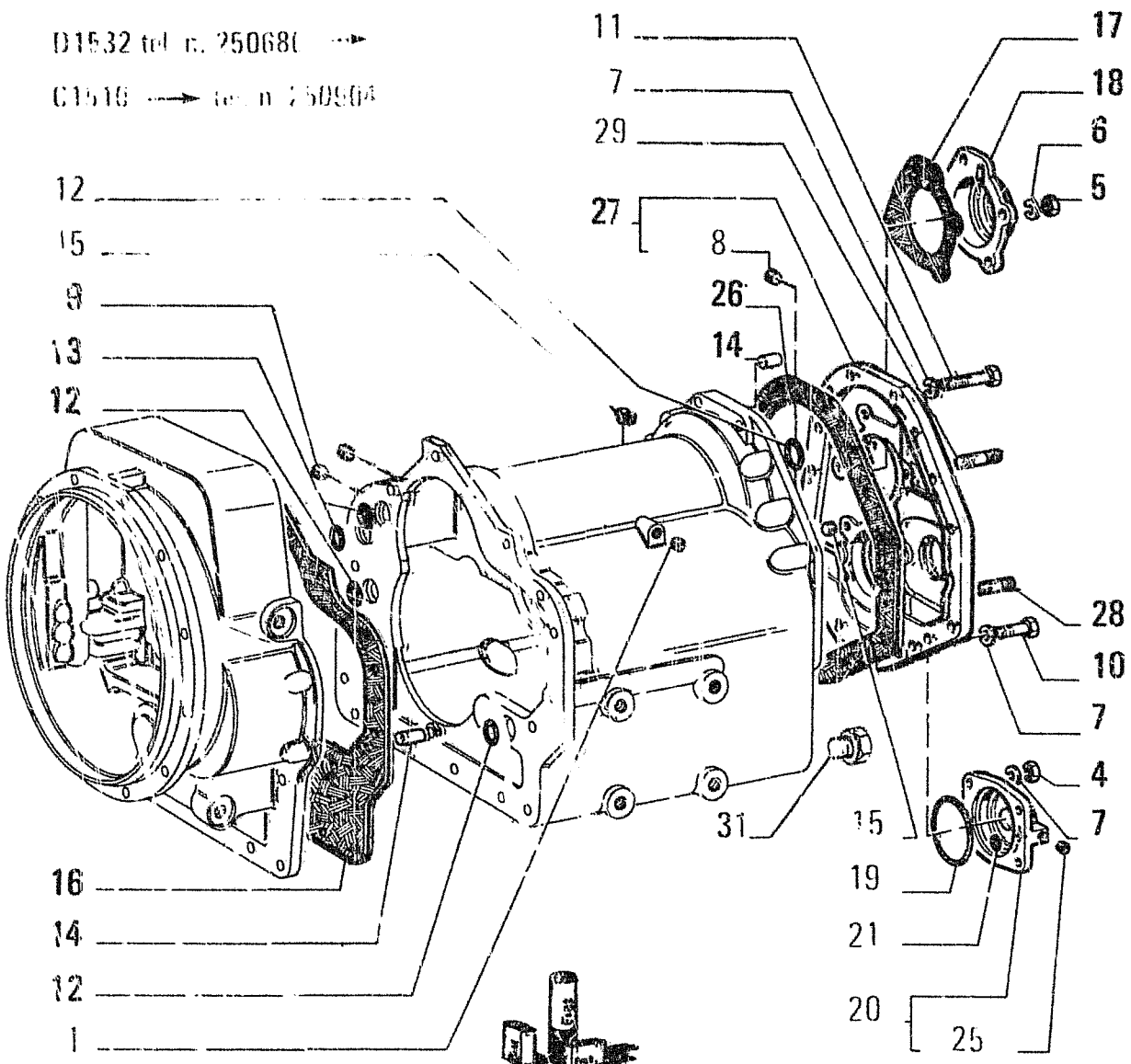

FIAT ALJIS FD7

ITEM	PART NUMBER	QTY	TRANS CODE	DESCRIPTION	DESCRIZIONE
1	70673860	1	50T	PLUG	TAPPO
4	70910986	4	10D	NUT	DADO
5	70911331	4	10D	NUT	LADO
6	70912433	4	131R	WASHER	ROSETTA
7	70914678	19	131R	WASHER	ROSETTA
8	73131677	1	50T	PLUG	TAPPO
9	79051077	2	50T	PLUG	TAPPO
10	70921569	6	40V	SCREW	VITE
11	70927583	9	40V	SCREW	VITE
12	14462980	3	158G	O-RING 3.53x20,22	GUARNIZIONE O-R 3,53x20,22
13	14457180	2	120G	GASKET 2,62x13,94	GUARNIZIONE PIANA 2,62x13,94
14	71014838	3	80P	PIN	PERNO
15	73061768	2	50T	PLUG	TAPPO
16	73118040	1	123G	SEAL ASSY	GUARNIZIONE TENUTA FRONTALE
17	79030211	1	123G	SEAL ASSY	GUARNIZIONE TENUTA FRONTALE
18	79030212	1	265C	COVER	COPERCHIO
19	79030215	1	158G	O-RING	GUARNIZIONE O-R
20	79030216	1	265C	COVER - ASSEMBLY	COPERCHIO - COMPLETO
21	79030217	1	158G	O-RING	GUARNIZIONE O-R
25	79030241	1	50T	PLUG	TAPPO
26	79030266	1	123G	SEAL ASSY	GUARNIZIONE TENUTA FRONTALE
27	79053435	1	265C	COVER - ASSEMBLY	COPERCHIO - COMPLETO
28	79031001	4	210P	STUD	PRIGIONIERO
29	79031002	4	210P	STUD	PRIGIONIERO
30	79055160	1	K	KIT SEE PAGE 9	KIT VED. PAG.9
31	79060009	1	50T	PLUG	TAPPO

79057724

TRANSMISSION - CAMBIO DI VELOCITA' - BOITE DE VITESSES - WECHSELGETRIEBE - CAMBIO DE VELOCIDADES

9

B2.01/A

4

N.T.R. 191 - 20.02.1990

604.01.081.04

FIATALLIS FD7

B2.01/ A TAV. 5 PAG.1

D1532 tel. n. 250686 -->

C1510 --> tel. n. 250904

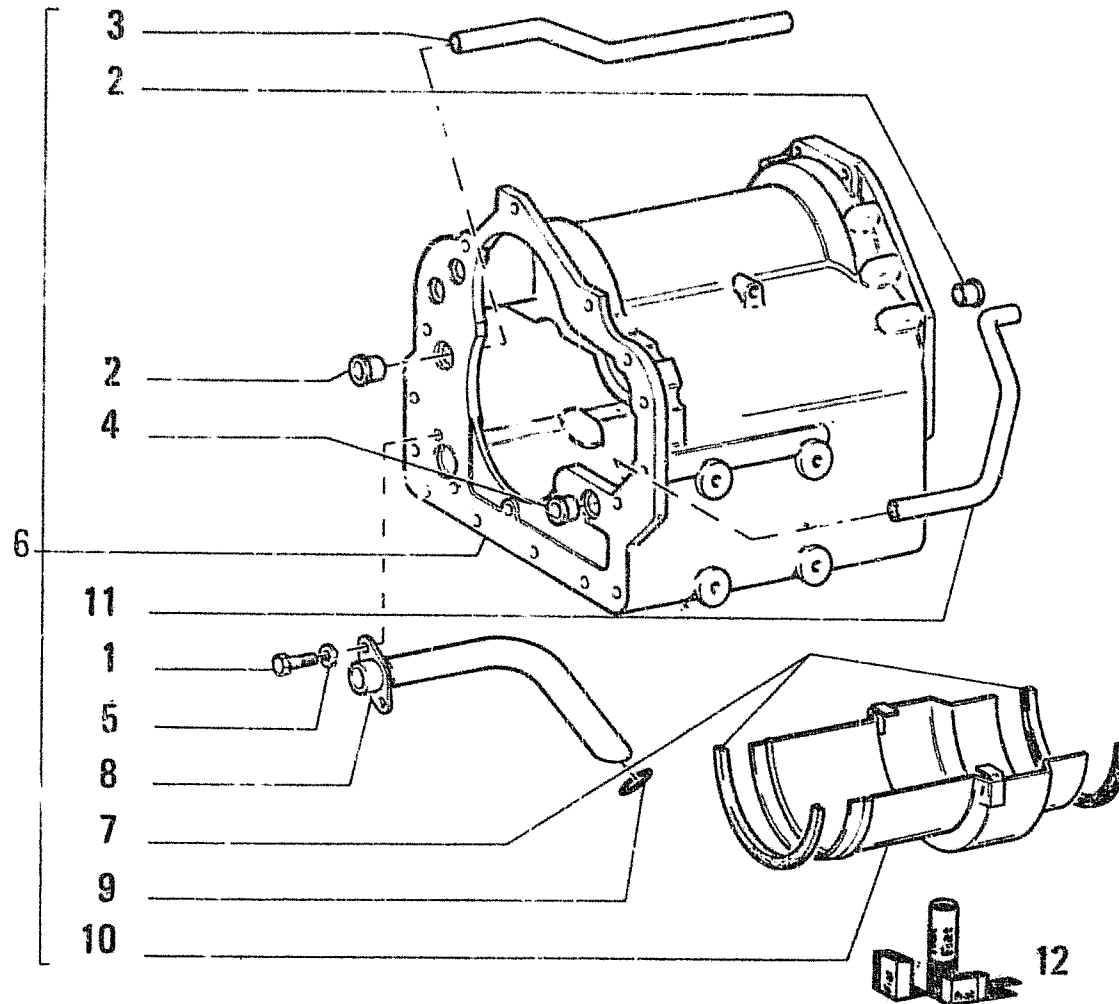

ITEM	PART NUMBER	QTY	TRANS CODE	DESCRIPTION	DESCRIZIONE
1	70927612	2	40V	SCREW	VITE
2	71004820	2	135M	HUB	MOZZO
3	73118043	1	193T	TUBE	TUBO RIGIDO
4	73118044	1	135M	HUB	MOZZO
5	10571779	2	131R	WASHER 8,1x2	ROSETTA 8,1x2
6	79056362	1	35S	CASE - ASSEMBLY	SCATOLA - COMPLETO
7	79030268	2	123G	SEAL ASSY	GUARNIZIONE TENUTA FRONTALE
8	79030269	1	193T	TUBE	TUBO RIGIDO
9	79030270	1	158G	O-RING	GUARNIZIONE O-R
10	79030271	1	20D	DEFLECTOR	DEFLETTORE
11	79030277	1	193T	TUBE	TUBO RIGIDO
12	79055160	1	1K	KIT SEE PAGE 9	KIT VED PAG.9

79057724

TRANSMISSION - CAMBIO DI VELOCITA' - BOITE DE VITESSES - WECHSELGETRIEBE - CAMBIO DE VELOCIDADES

9

B2.01/A

5

N.T.R. 191 - 20.02.1990

604.01.081.04

R5

D1532 tel. n. 250686 →

C1510 → tel. n. 250904

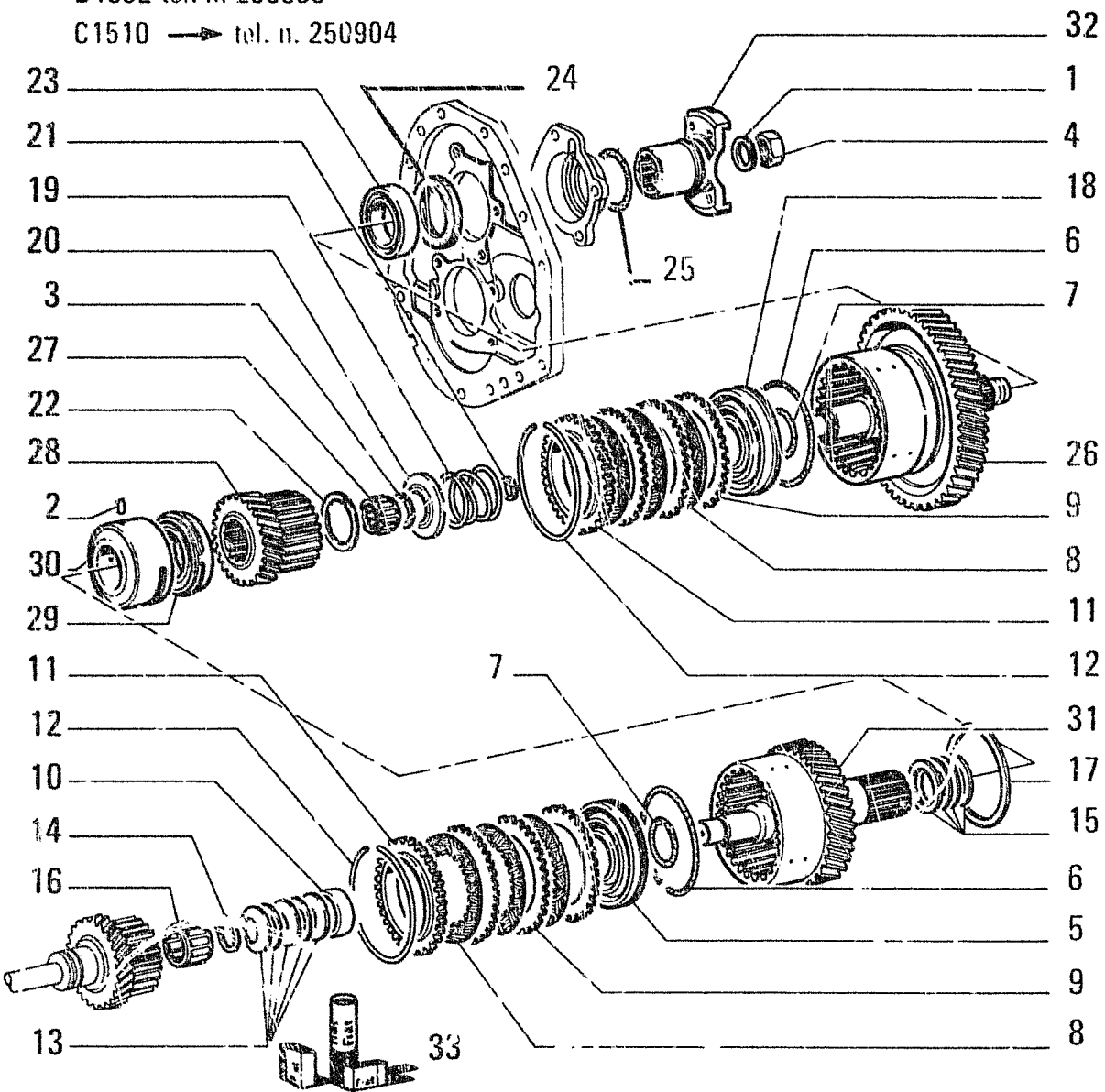

FIATALLIS FD7

I T E M	PART NUMBER	Q T Y	TRANS CODE	DESCRIPTION	DESCRIZIONE
1	70673871	1	131R	WASHER	ROSETTA
2	79063942	1	80P	PIN	PERNO
3	70926000	1	51A	LOCKRING	ANELLO DI SICUREZZA
4	73109871	1	10D	NUT	DADO
5	73118085	1	130P	PLUNGER	PISTONCINO
6	73118086	1	123G	SEAL ASSY	GUARNIZIONE TENUTA FRONTALE
7	73118087	2	123G	SEAL ASSY	GUARNIZIONE TENUTA FRONTALE
8	73118088	14	60D	DISC	DISCO
9	73118089	14	60D	DISC	DISCO
10	73118090	1	75D	SPACER	DISTANZIALE
11	73118091	2	60D	DISC	DISCO
12	73118092	2	45A	RING	ANELLO
13	73118093	5	100M	SPRING	MOLLA
14	73118094	1	51A	LOCKRING	ANELLO DI SICUREZZA
15	73118096	4	45A	RING	ANELLO
16	73118097	1	341C	BEARING	CUSCINETTO
17	73118098	1	51A	LOCKRING	ANELLO DI SICUREZZA
18	73118106	1	130P	PLUNGER	PISTONCINO
19	73118107	1	100M	SPRING	MOLLA
20	73118108	1	60S	CUP	SCODELLINO
21	73118136	1	45A	RING	ANELLO
22	79051090	1	51A	LOCKRING	ANELLO DI SICUREZZA
23	79030209	1	341C	BEARING	CUSCINETTO
24	79030210	1	123G	SEAL ASSY	GUARNIZIONE TENUTA FRONTALE
25	14463880	1	158G	O-RING 3,53x34,52	GUARNIZIONE O-R 3,53x34,52
26	79030225	1	16A	SHAFT	ALBERO
27	79030226	1	341C	BEARING	CUSCINETTO

79057724

TRANSMISSION - CAMBIO DI VELOCITA' - BOITE DE VITESSES - WECHSELGETRIEBE - CAMBIO DE VELOCIDADES

9	B2.01 / A	6
N.T.R. 191 - 20.02.1990		
604.01.081.04		

R6

D1532 tel. n. 250686 →
 C1510 → tel. n. 250904

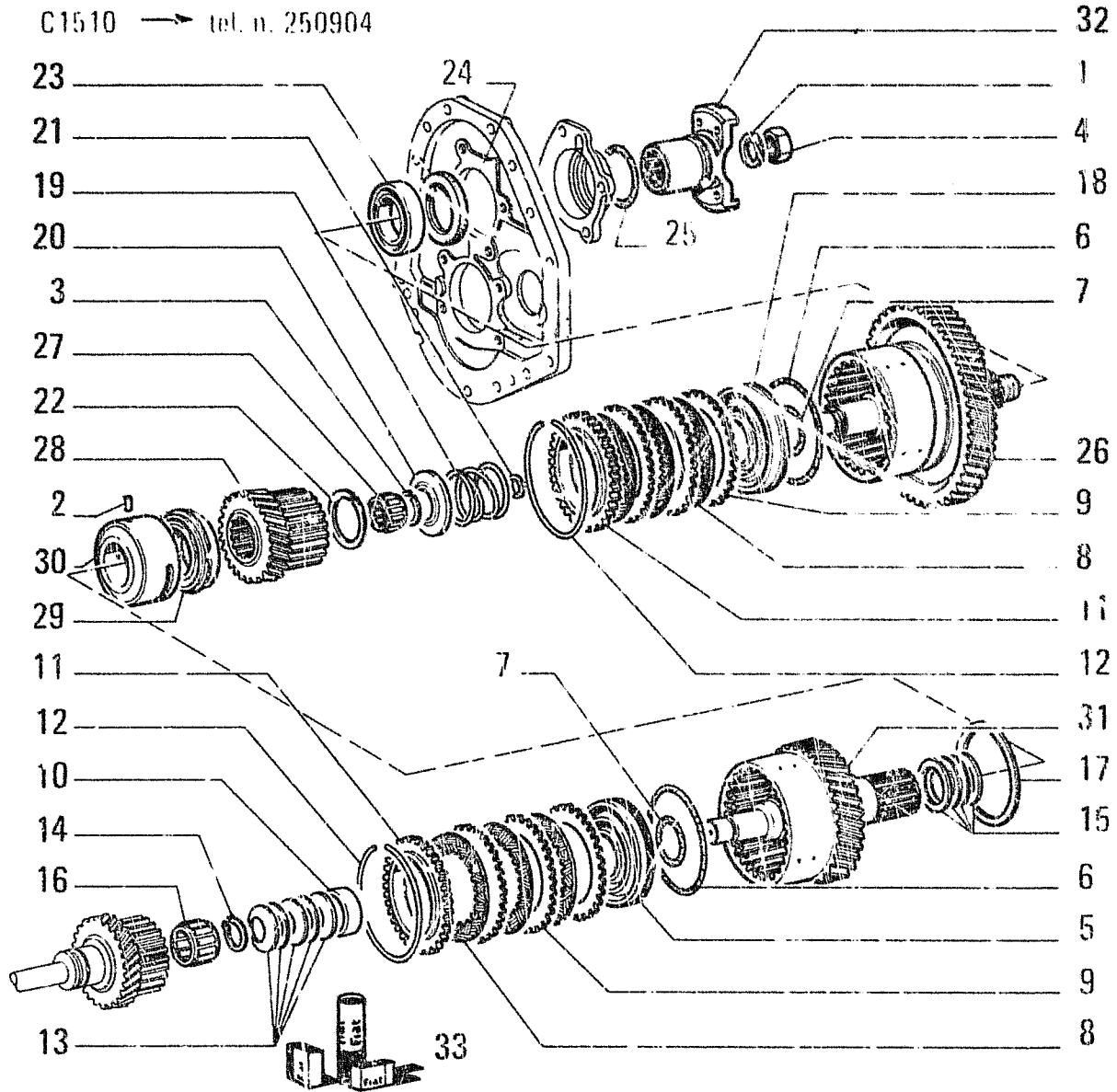

FIATALLIS FD7

B2.01/ A TAV. 6 PAG.2

ITEM	PART NUMBER	QTY	TRANS CODE	DESCRIPTION	DESCRIZIONE
					32
					1
					4
28	79060005	1	50I GEAR		18
29	79030230	1	341C BEARING		6
30	79064245	1	135M HUB		7
31	79030232	1	16A SHAFT		26
32	79031240	1	70F FLANGE		9
33	79055160	1	1K KIT SEE PAGE 9		8

790:774

TRANSMISSION - CAMBIO DI VELOCITA' - BOITE DE VITESSES - WECHSELGETRIEBE - CAMBIO DE VELOCIDADES

9
 B2.01 / A 6
 N.T.R. 191 - 20.02.1990
 604.01.081.04

R7

D1532 tel. n. 250686 →

C1510 → tel. n. 250904

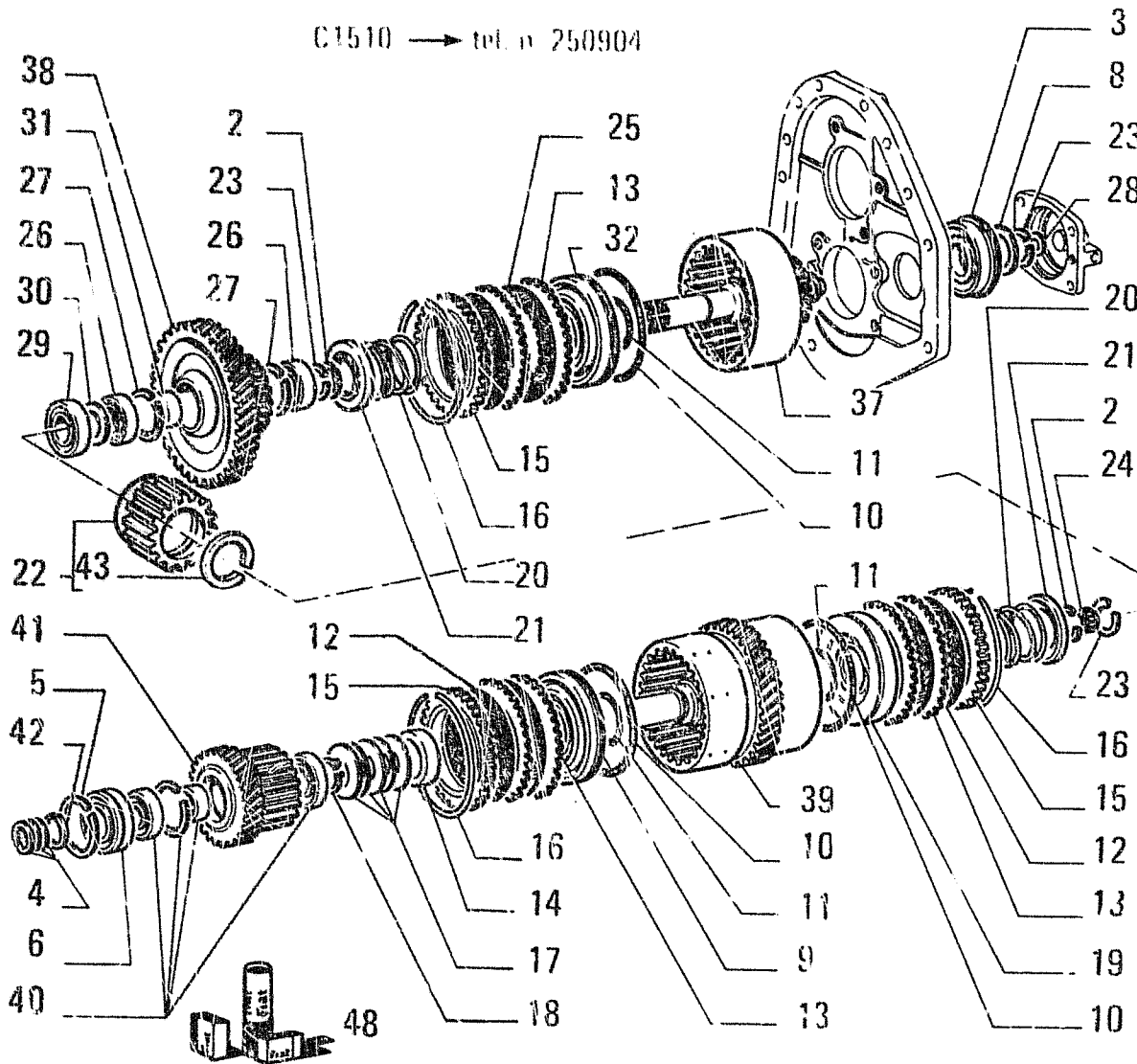

ITEM	PART NUMBER	QTY	TRANS CODE	DESCRIPTION	DESCRIZIONE
2	70926000	2	51A	LOCKRING	ANELLO DI SICUREZZA
3	73132784	1	341C	BEARING	CUSCINETTO
4	71004926	3	45A	RING	ANELLO
5	71004961	1	51A	LOCKRING	ANELLO DI SICUREZZA
6	71004962	1	341C	BEARING	CUSCINETTO
8	73118058	1	131R	WASHER	ROSETTA
9	73118085	1	130P	PLUNGER	PISTONCINO
10	73118086	3	123G	SEAL ASSY	GUARNIZIONE TENUTA FRONTALE
11	73118087	3	123G	SEAL ASSY	GUARNIZIONE TENUTA FRONTALE
12	73118089	14	60D	DISC	DISCO
13	73118089	22	60D	DISC	DISCO
14	73118090	1	75D	SPACER	DISTANZIALE
15	73118091	3	60D	DISC	DISCO
16	73118092	3	45A	RING	ANELLO
17	73118093	5	100M	SPRING	MOLLA
18	73118094	1	51A	LOCKRING	ANELLO DI SICUREZZA
19	73118106	1	130P	PLUNGER	PISTONCINO
20	73118107	2	100M	SPRING	MOLLA
21	73118108	2	60S	CUP	SCODELLING
22	79052636	1	135M	HUB - ASSEMBLY	MOZZO - COMPLETO
23	73118110	3	51A	LOCKRING	ANELLO DI SICUREZZA
24	73118111	1	341C	BEARING	CUSCINETTO
25	73118133	8	60D	DISC	DISCO
26	73118134	2	341C	BEARING	CUSCINETTO
27	73118135	2	51A	LOCKRING	ANELLO DI SICUREZZA
28	73118136	1	45A	RING	ANELLO
29	73118137	1	341C	BEARING	CUSCINETTO

79057724

TRANSMISSION -- CAMBIO DI VELOCITA' -- BOITE DE VITESSES -- WECHSELGETRIEBE -- CAMBIO DE VELOCIDADES

9
B2.01/A 7
N.T.R. 191 - 20.02.1990
604.01.081.04

FIATALLIS FD7

D1532 tel. n. 250686 →

C1510 → tel. n. 250904

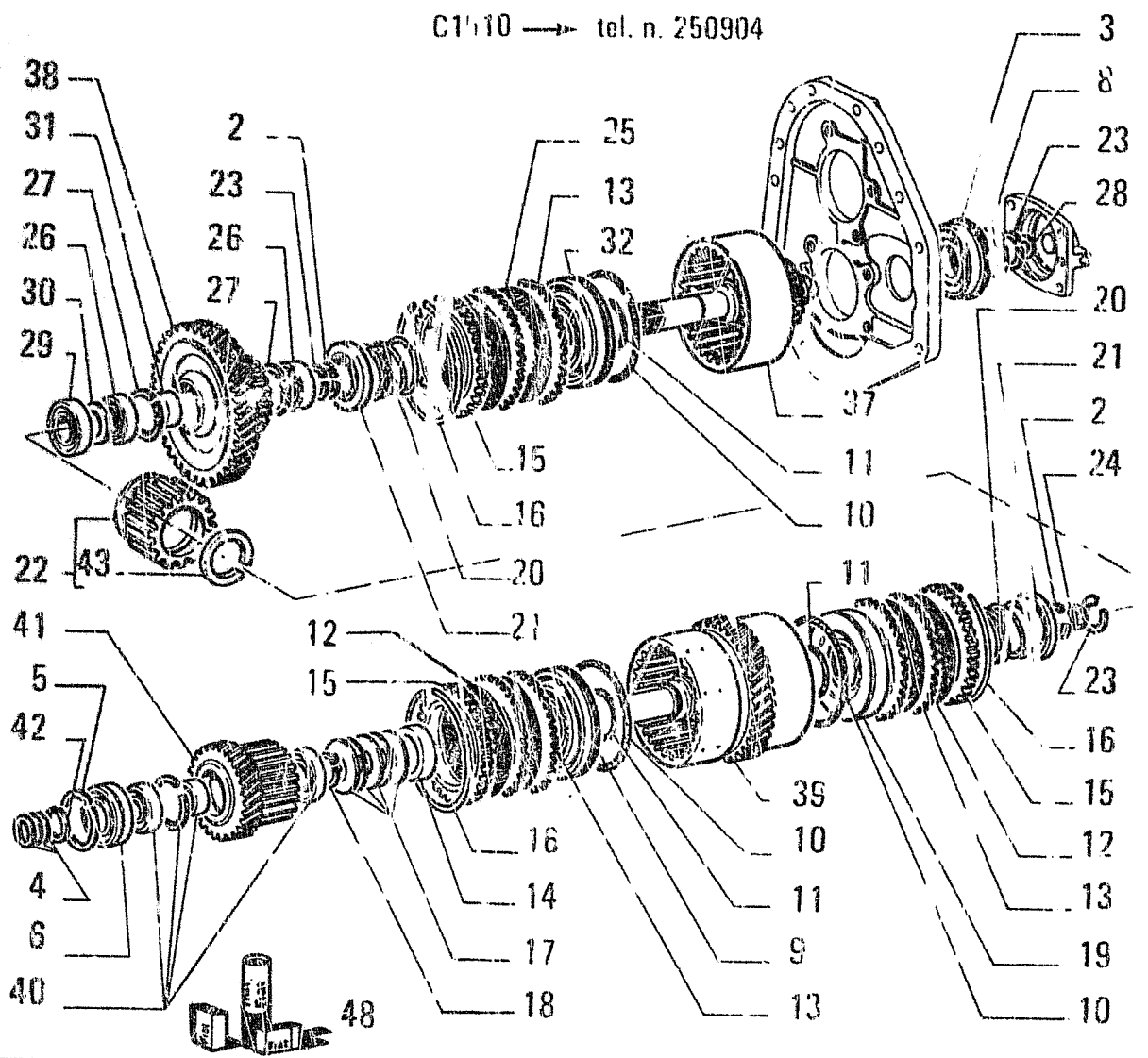

ITEM	PART NUMBER	QTY	TRANS CODE	DESCRIPTION	DESCRIZIONE
	30	1	75D	SPACER	DISTANZIALE
	31	1	75D	SPACER	DISTANZIALE
	32	1	130P	PLUNGER	PISTONCINO
	37	1	16A	SHAFT	ALBERO
	38	1	50I	GEAR	INGRANAGGIO
	39	1	16A	SHAFT	ALBERO
	40	1	341C	BEARING	CUSCINETTO
	41	1	50I	GEAR	INGRANAGGIO
	42		45A	RING	ANELLO
	79030237		45A	RING	ANELLO
	79030238		45A	RING	ANELLO
	79030239		45A	RING	ANELLO
	79030240		45A	RING	ANELLO
	43	1	51A	LOCKRING	ANELLO DI SICUREZZA
	48	1	1K	KIT SEE PAGE 9	KIT VED. PAG 9

79057724

TRANSMISSION - CAMBIO DI VELOCITA' - BOITE DE VITESSES - WECHSELGETRIEBE - CAMBIO DE VELOCIDADES

9 B2.01/A 7
 N.T.R. 191 - 20.02.1990
 604.01.081.04



D1510 tel. n. 250905 →

CASINGS AND COVERS
SCATOLE E COPERCHI

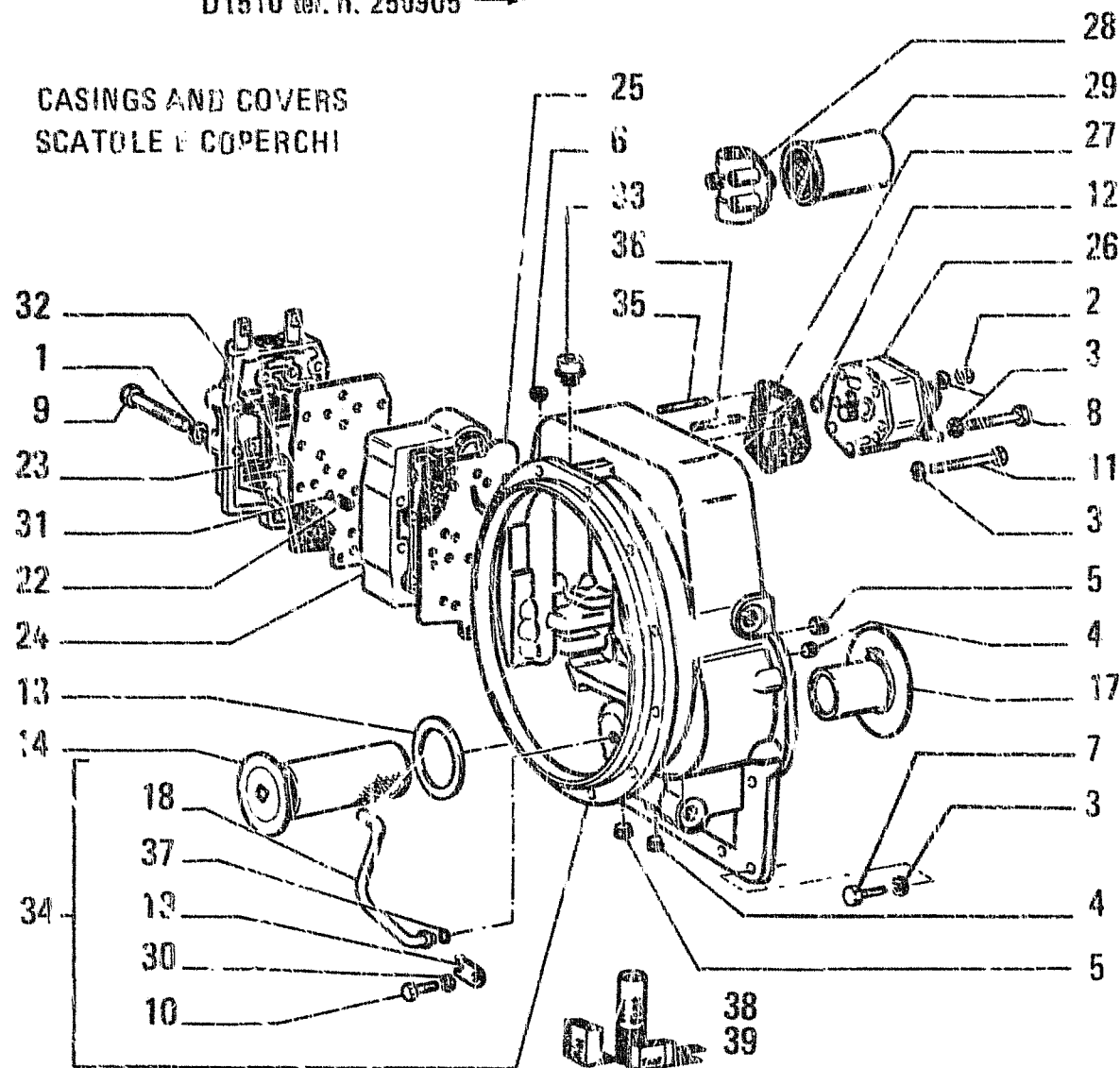

FIATALLIS FD7

B2.01/ B TAV. 1 PAG.1

QTY	PART NUMBER	TRANS CODE	DESCRIPTION	DESCRIZIONE
9	10516879	170R	LOCKWASHER 10,2x2,5	ROSETTA EL. 10,2x2,5
2	70910986	10D	NUT	DADO
21	70914678	131R	WASHER	ROSETTA
2	73131677	50T	PLUG	TAPPO
2	70917970	50T	PLUG	TAPPO
1	79051077	50T	PLUG	TAPPO
16	70921569	40V	SCREW	VITE
2	70925321	40V	SCREW	VITE
9	70927536	40V	SCREW	VITE
1	70927612	40V	SCREW	VITE
1	70928527	40V	SCREW	VITE
1	14457180	158G	O-RING 2,62x13,94	GUARNIZIONE O-R 2,62x13,94
1	71004343	123G	SEAL ASSY	GUARNIZIONE TENUTA FRONTALE
1	71004849	65F	FILTER	FILTRO
1	73118033	135M	HUB	MOZZO
1	73118051	133T	TUBE	TUBO RICICLO
1	73118054	45F	CLIP	FERMAGLIO
2	73118121	100M	SPRING	MOLLA
1	73118122	123G	SEAL ASSY C2911	GUARNIZIONE TENUTA FRONTALE C2911
1	79086375	122G	SEAL D2911	GUARNIZIONE D2911
1	79060010	10V	VALVE - ASSEMBLY SEE SGR. 92.34/A	VALVOLA - COMPLETO VEDERIE SGR. B2.34/A
1	73118124	123G	SEAL ASSY	GUARNIZIONE TENUTA FRONTALE
1	79051076	155P	PUMP	POMPA
1	73118167	123G	SEAL ASSY	GUARNIZIONE TENUTA FRONTALE
1	73118170	20R	FITTING	RACCORDO

79064265

9

TRANSMISSION -- CAMBIO DI VELOCITA' -- BOITE DE VITESSES -- WECHSELGETRIEBE --
CAMBIO DE VELOCIDADES

B2.01/B

1

N.T.R. 205 - 30.09.1991

604.01.081.03

R10

D1510 tel. n. 250505 -->

CASING AND COVERS
SCATOLE E COPERCHI

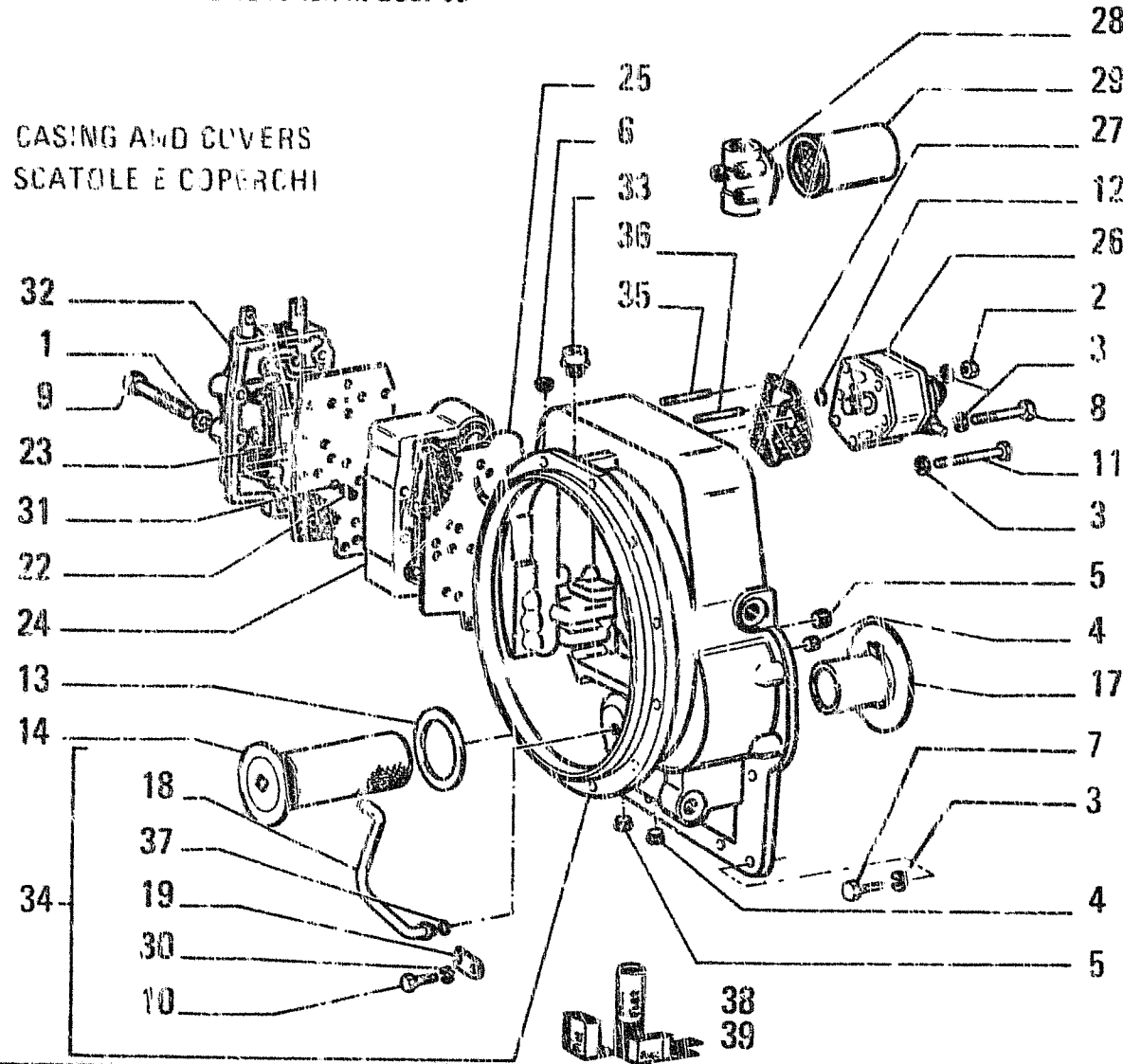

FIATALLIS FD7

B2.01/ B TAV. 1 PAG.2

ITEM	PART NUMBER	QTY	TRANS CODE	DESCRIPTION	DESCRIZIONE
29	73118171	1	65F	FILTER C2951	FILTRO C2951
	79104646	1	35F	FILTER D2951	FILTRO D2951
30	10571779	1	131R	WASHER 8.1x2	ROSETTA 8.1x2
31	70905360	2	140S	BALL	SFERA
32	79060012	1	83D	CONTROL VALVE - ASSEMBLY SEE SGR B2.33/A	DISTRIBUTORE - COMPLETO VEDERE SGR B2.33/A
33	79030263	1	50I	PLUG	TAPPO
34	79056361	1	35S	CASE - ASSEMBLY	SCATOLA - COMPLETO
35	79030999	1	210F	STUD	PRIGIONIERO
36	79031000	1	210F	STUD	PRIGIONIERO
37	79031003	1	158G	O-RING	GUARNIZIONE O-R
38	79055159	1	1K	KIT SEE PAGE 9	KIT VED PAG 9
39	79055160	1	1K	KIT SEE PAGE 9	KIT VED PAG 9

79054265

TRANSMISSION - CAMBIO DI VELOCITA' - BOITE DE VITESSES - WECHSELGETRIEBE -
CAMBIO DE VELOCIDADES

9

B2.01/B

N.T.R. 205 30.09.1991

604 01 081.06

R11

D1510 tel. n. 25NS/05

CASINGS AND COVERS
SCATOLE E COPERCHI

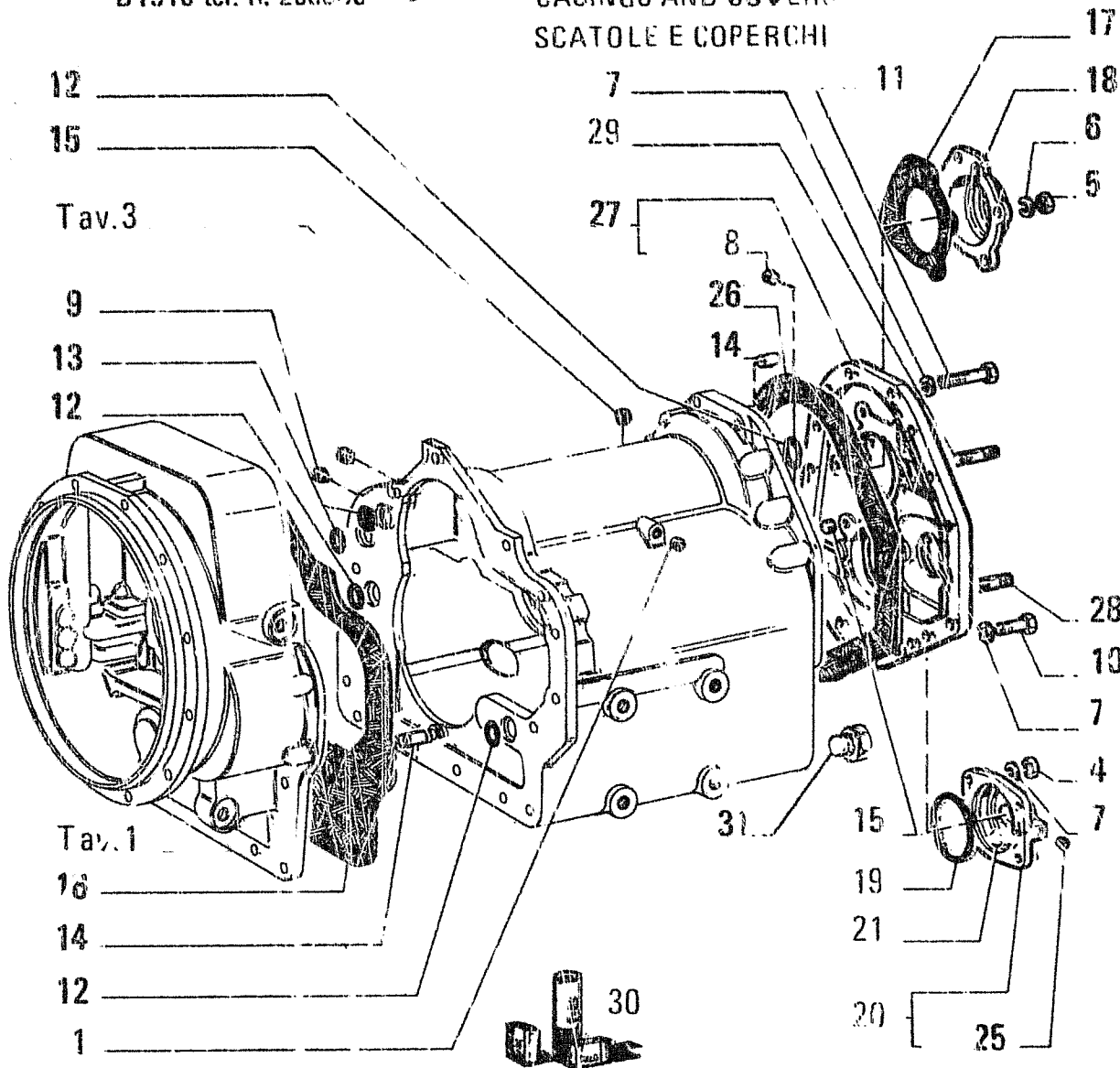

FIATALLIS FD7

FR.01/ B TAV. 2 PAG.1

ITEM	PART NUMBER	QTY	TRANS CODE	DESCRIPTION	DESCRIZIONE
1	70673860	1	50T PLUG	TAPPO	TAPPO
4	70910986	4	10D NUT	DADO	DADO
5	70911931	4	10D NUT	DADO	DADO
6	70912433	4	131R WASHER	ROSETTA	ROSETTA
7	70914678	19	131F WASHER	ROSETTA	ROSETTA
8	73111677	1	5F PLUG	TAPPO	TAPPO
9	79051077	2	5T PLUG	TAPPO	TAPPO
10	70521569	6	40V SCREW	VITE	VITE
11	70527583	9	40V SCREW	VITE	VITE
12	14-62980	3	158G O-RING 3.53x20,22	GUARNIZIONE O-R 3.53x20,22	GUARNIZIONE O-R 3.53x20,22
13	14-157180	2	120G CASKET 2,62x13,94	GUARNIZIONE PIANA 2,62x13,94	GUARNIZIONE PIANA 2,62x13,94
14	71004838	3	80P PIN	PERNO	PERNO
15	73066768	1	50T PLUG	TAPPO	TAPPO
16	79118040	1	123G SEAL ASSY	GUARNIZIONE TENUTA FRONTALE	GUARNIZIONE TENUTA FRONTALE
17	79030211	1	123G SEAL ASSY	GUARNIZIONE TENUTA FRONTALE	GUARNIZIONE TENUTA FRONTALE
18	79065193	1	265C COVER	COPERCHIO	COPERCHIO
19	79030215	1	158G O-RING	GUARNIZIONE O-R	GUARNIZIONE O-R
20	79030215	1	265C COVER - ASSEMBLY C2950	COPERCHIO - COMPLETO C2950	COPERCHIO - COMPLETO C2950
	79102690	1	265C COVER - ASSEMBLY D2950	COPERCHIO - COMPLETO D2950	COPERCHIO - COMPLETO D2950
21	79030217	1	158G O-RING	GUARNIZIONE O-R	GUARNIZIONE O-R
25	79031241	1	50T PLUG	TAPPO	TAPPO
26	79030266	1	123G SEAL ASSY	GUARNIZIONE TENUTA FRONTALE	GUARNIZIONE TENUTA FRONTALE
27	79053435	1	265C COVER - ASSEMBLY	COPERCHIO - COMPLETO	COPERCHIO - COMPLETO
28	79031001	4	210P STUD	PRIGIONIERO	PRIGIONIERO
29	79031002	4	210P STUD	PRIGIONIERO	PRIGIONIERO

79064265

TRANSMISSION - CAMBIO DI VELOCITA -- BOITE DE VITESSES - WECHSELGETRIEBE - CAMBIO DE VELOCIDADES

B2.01/B

2

M.T.R. 205 - 30.09.1991
604.01.081.06

R12

D1510 tel. n. 250905 →

CASING AND COVERS
SCATOLE E COPERCHI

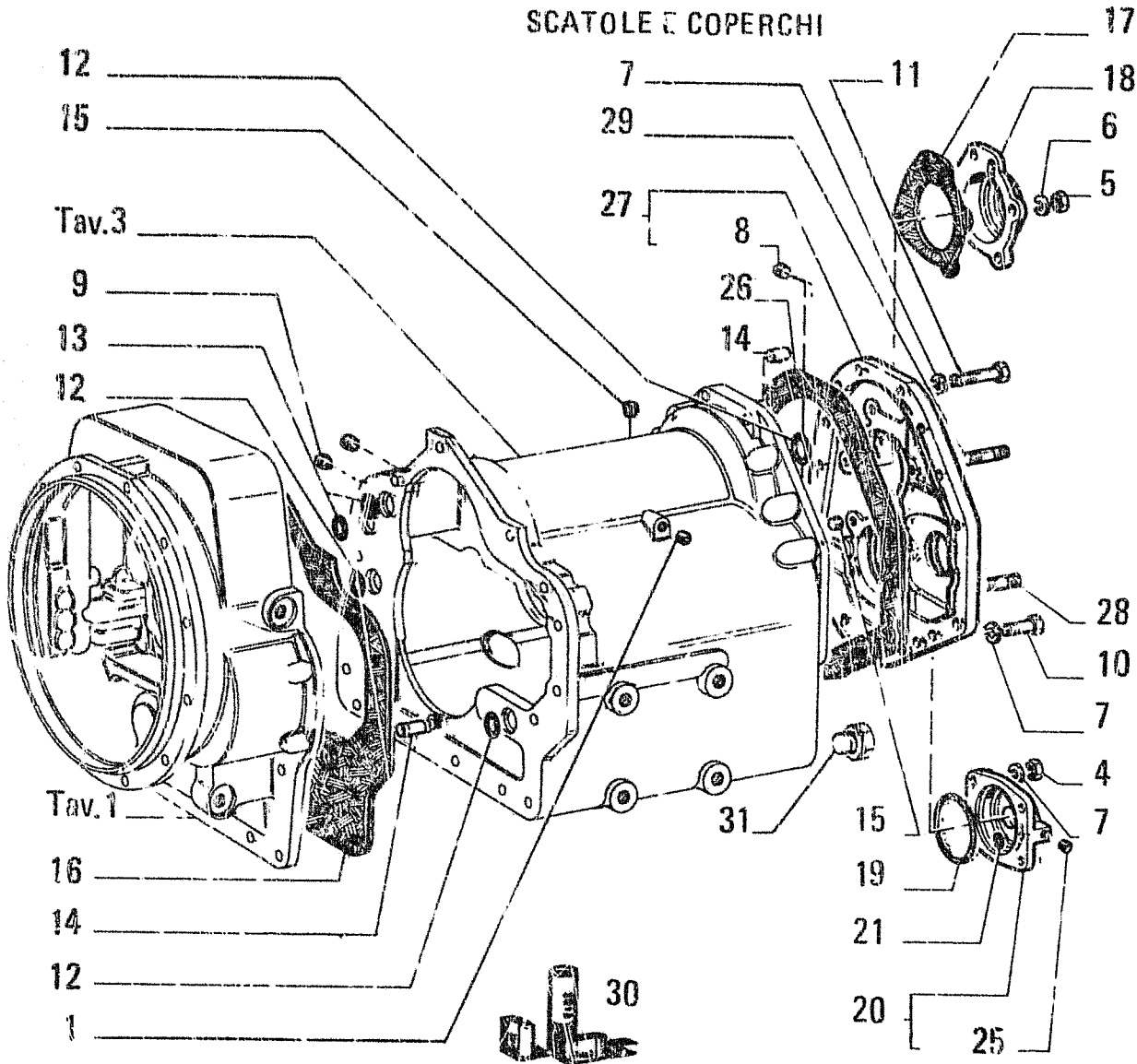

FIATALLIS FD7

B2.01/ B TAV 2 PAG.2

ITEM	PART NUMBER	QTY	TRANS CODE	DESCRIPTION	DESCRIZIONE
30	79055160	1	1K	SEE PAGE 9	KIT VER PAG 9
31	79060009	1	50T	PLUG	TAPPO

79064265

TRANSMISSION - CAMBIO DI VELOCITA - BOITE DE VITESSES - WECHSELGETRIEBE - CAMBIO DE VELOCIDADES

9

B2.01/B

2

N.T.R. 205 - 30.09.1991
604.01.081.06

R13

D1510 tel. n. 250905 →

CASINGS AND COVERS
SCATOLE E COPERCHI

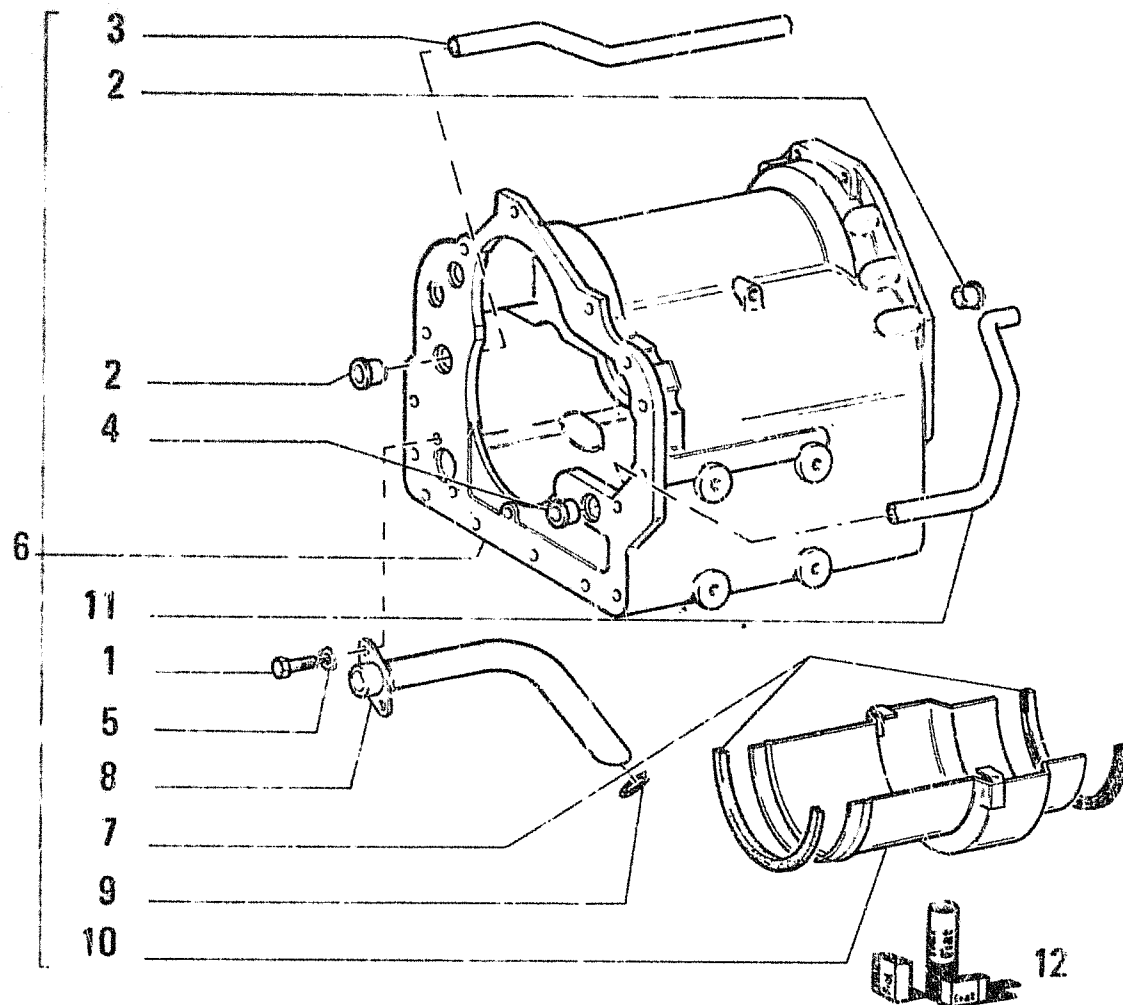

FIATALLIS FD7

B2.01/ B TAV. 3 PAG.1

I T E M	PART NUMBER	Q T Y	TRANS CODE	DESCRIPTION	DESCRIZIONE
1	70927612	2	40V	SCREW	VITE
2	71004820	2	135M	HUB	MOZZO
3	73118043	1	193T	TUBE	TUBO RIGIDO
4	73118044	1	135M	HUB	MOZZO
5	10571779	2	131R	WASHER 8,1x2	ROSETTA 8,1x2
6	79056362	1	35S	CASE - ASSEMBLY	SCATOLA - COMPLETO
7	79030268	2	123G	SEAL ASSY	GUARNIZIONE TENUTA FRONTALE
8	79030269	1	193T	TUBE	TUBO RIGIDO
9	79030270	1	158G	O-RING	GUARNIZIONE O-R
10	79030271	1	20D	DEFLECTOR	DEFLETTORE
11	79030277	1	193T	TUBE	TUBO RIGIDO
12	79055160	1	1K	KIT SEE PAGE 9	KIT VED PAG.9

79064265

TRANSMISSION - CAMBIO DI VELOCITA' - BOITE DE VITESSES - WECHSELGETRIEBE - CAMBIO DE VELOCIDADES

e

B2.01/B

3

N.T.R. 205 - 30.09.1991

604.01.081.06

R14

V8A

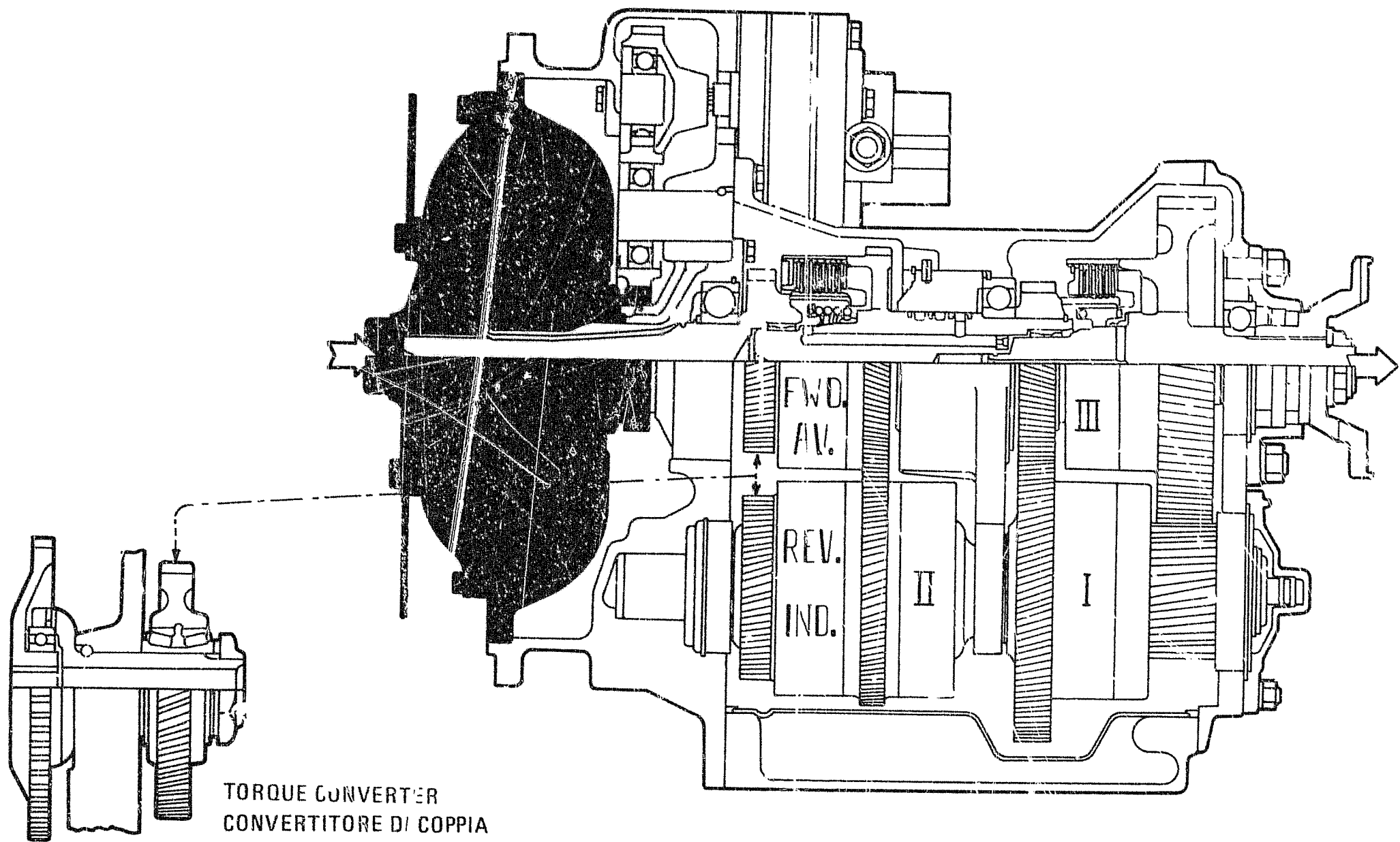

TORQUE CONVERTER
CONVERTITORE DI COPPIA

79064265

TRANSMISSION - CAMBIO DI VELOCITA' - BOITE DE VITESSES - WECHSELGETRIEBE - CAMBIO DE VELOCIDADES

B2 01 B

4

N.T.R. 205 - 30.09.1991
604.91.081.06

R15

TORQUE CONVERTER
CONVERTITORE DI COPPIA

D 15 10 tel. n. 250905 →

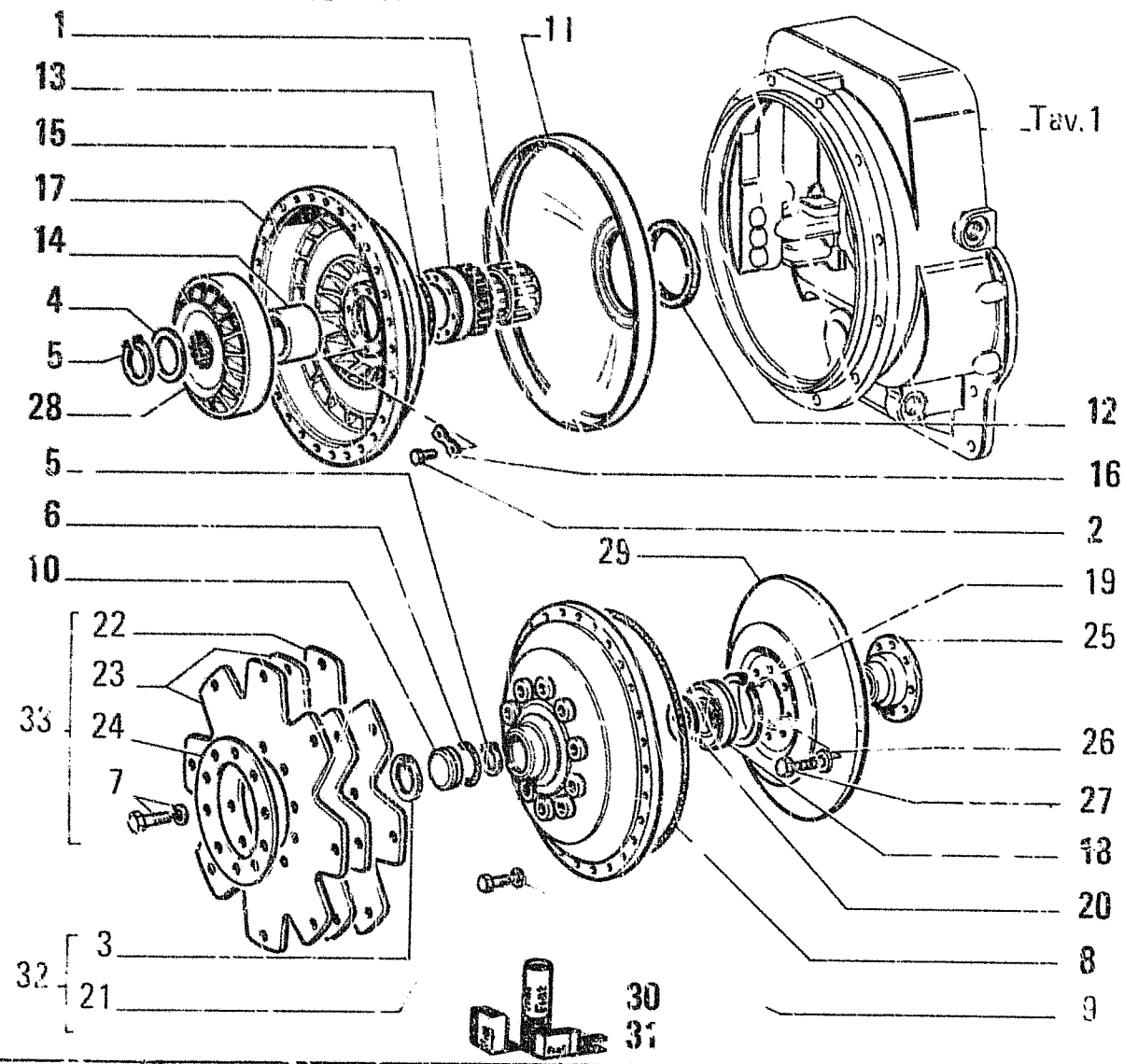

Tav. 1

FIATALLIS FD7

ITEM	PART NUMBER	QTY	TRANS CODE	DESCRIPTION	DESCRIZIONE
1	70673970	1	341C	BEARING	CUSCINETTO
2	79051207	8	40V	SCREW	VITE
3	79111658	1	187A	SNAP RING C2950	ANELLO ELASTICO C2950
4	70927747	1	45A	RING	ANELLO
5	70928720	2	51A	LOCKRING	ANELLO DI SICUREZZA
6	14458580	1	158G	O-RING 2,62x36,17	GUARNIZIONE O-R 2.62x36.17
7	71004835	10	44V	SCREW AND WASHER ASSY C2950	VITE CON ROSETTA C2950
8	71005536	1	159G	O-RING	GUARNIZIONE O-R
9	71008468	24	44V	SCREW AND WASHER ASSY	VITE CON ROSETTA
10	73117963	1	50T	PLUG	TAPPO
11	73113063	1	29D	DEFLECTOR	DEFLETTORE
12	73118064	1	122G	SEAL	GUARNIZIONE
13	73118065	1	50I	GEAR	INGRANAGGIO
14	73118066	1	75D	SPACER	DISTANZIALE
15	73118067	1	158G	O-RING	GUARNIZIONE O-R
16	73118068	8	110P	PLAQUE	PIASTRINA
17	73118069	1	60G	IMPELLER	GIRANTE
18	73118072	1	341C	BEARING	CUSCINETTO
19	73118073	1	51A	LOCKRING	ANELLO DI SICUREZZA
20	73118074	1	131R	WASHER	ROSETTA
21	73132674	1	265C	COVER C2950	COPERCHIO C2950
22	73118173	1	75M	DIAPHRAGM C2950	MEMBRANA C2950
23	73118174	2	75M	DIAPHRAGM C2950	MEMBRANA C2950
24	73118175	1	45A	RING C2950	ANELLO C2950
25	79051688	1	135M	HUB	MOZZO
26	71004797	12	131R	WASHER	ROSETTA

79064265

9

TRANSMISSION - CAMBIO DI VELOCITA' - BOITE DE VITESSES - WECHSELGETRIEBE - CAMBIO DE VELOCIDADES

B2.01/B

5

N.T.R. 205 - 30.09.1991
604.01.081.06

R16

TORQUE CONVERTER
CONVERTITORE DI COPPIA

D 1510 Tel.n. 250905 →

Tav. 1

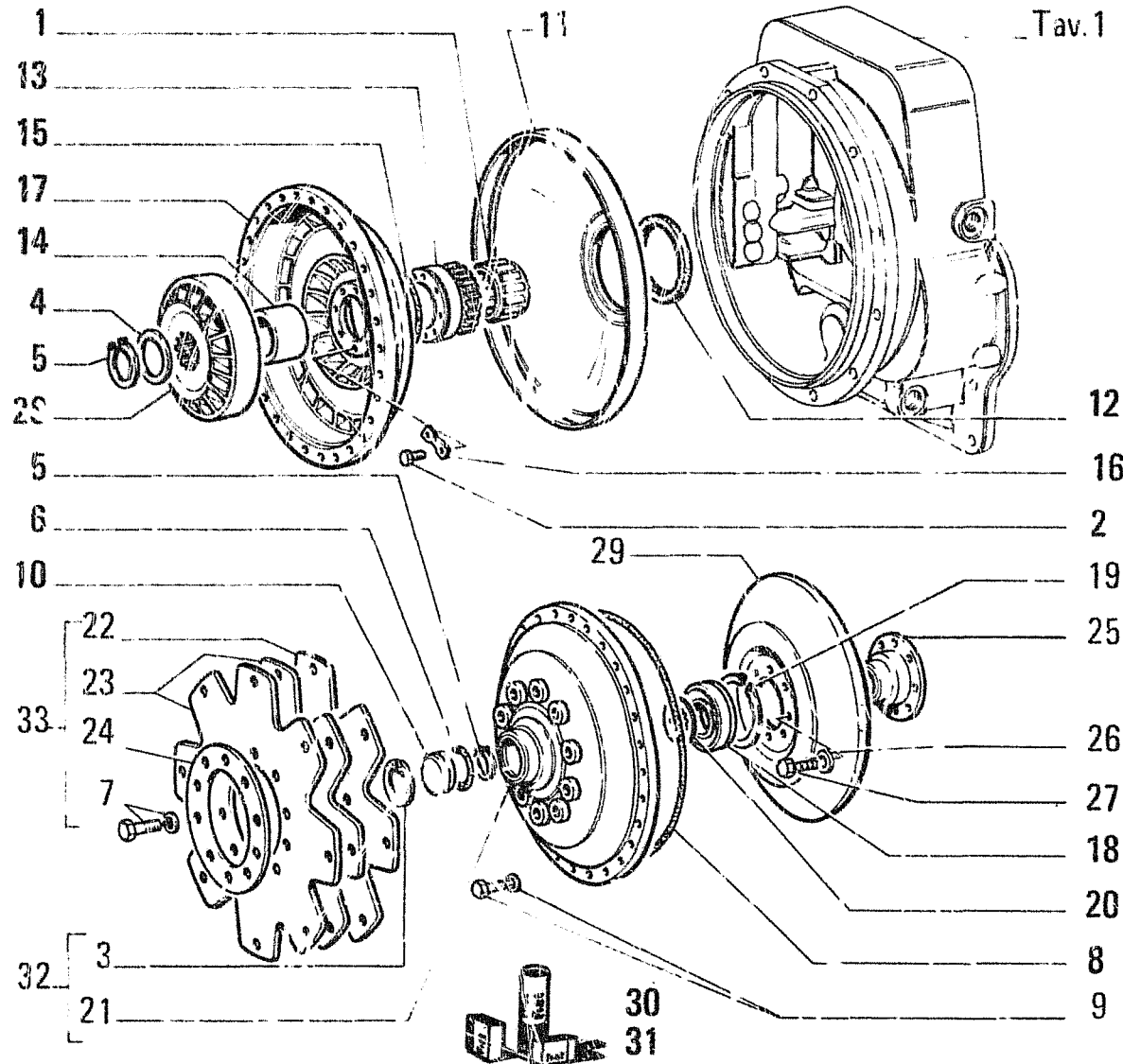

FIATALLIS FD7

B2.01/ B TAV. 5 PAG.2

ITEM	PART NUMBER	QTY	TRANS CODE	DESCRIPTION	DESCRIZIONE
27	71004795	12	40V	SCREW	VITE
28	79060011	1	271S	STATOR	STATORE
29	79056360	1	60G	IMPELLER	GIRANTE
30	79055159	1	1K	KIT SEE PAGE 9	KIT VED. PAG. 9
31	79055160	1	1K	KIT SEE PAGE 9	KIT VED. PAG. 9
32	79086374	1	265C	COVER D2950	COPERCHIO D2950
33	79102227	1	75M	DIAPHRAGM D2950	MEMBRANA D2950

TRANSMISSION
VELOCIDADES

- CAMBIO DI VELOCITA'

79064265

- BOITE DE VITESSES

- WECHSELGETREBE

- CAMBIO DE

9

B2.01/B

5

N.T.R. 205 - 30.09.1991

604.01.081.06

R17

B

MECHANICAL TRANSMISSION • CLUTCH • TRANSMISSION • TRANSMISSION SHAFT • AXLES
TRASMISSIONE MECCANICA • FRIZIONE • CAMBIO • ALBERO DI TRASMISSIONE • PONTI
TRANSMISSION MECANIQUE • EMBRAYAGE • BOITE DE VITESSES • ARBRE DE TRANSMISSION • PONTS
MECHANISCHE KRAFTÜBERTRAGUNG • KUPPLUNG • GETRIEBE • GELINKWELLE • ACHSEN
TRANSMISSION MECANICA • EMBRAQUE • CAMBIO • ARBOL DE TRANSMISSION • PUENTES

OPTIONAL
VARIANTE 30 0289.02.1

C 1510 → tel. n. 250904

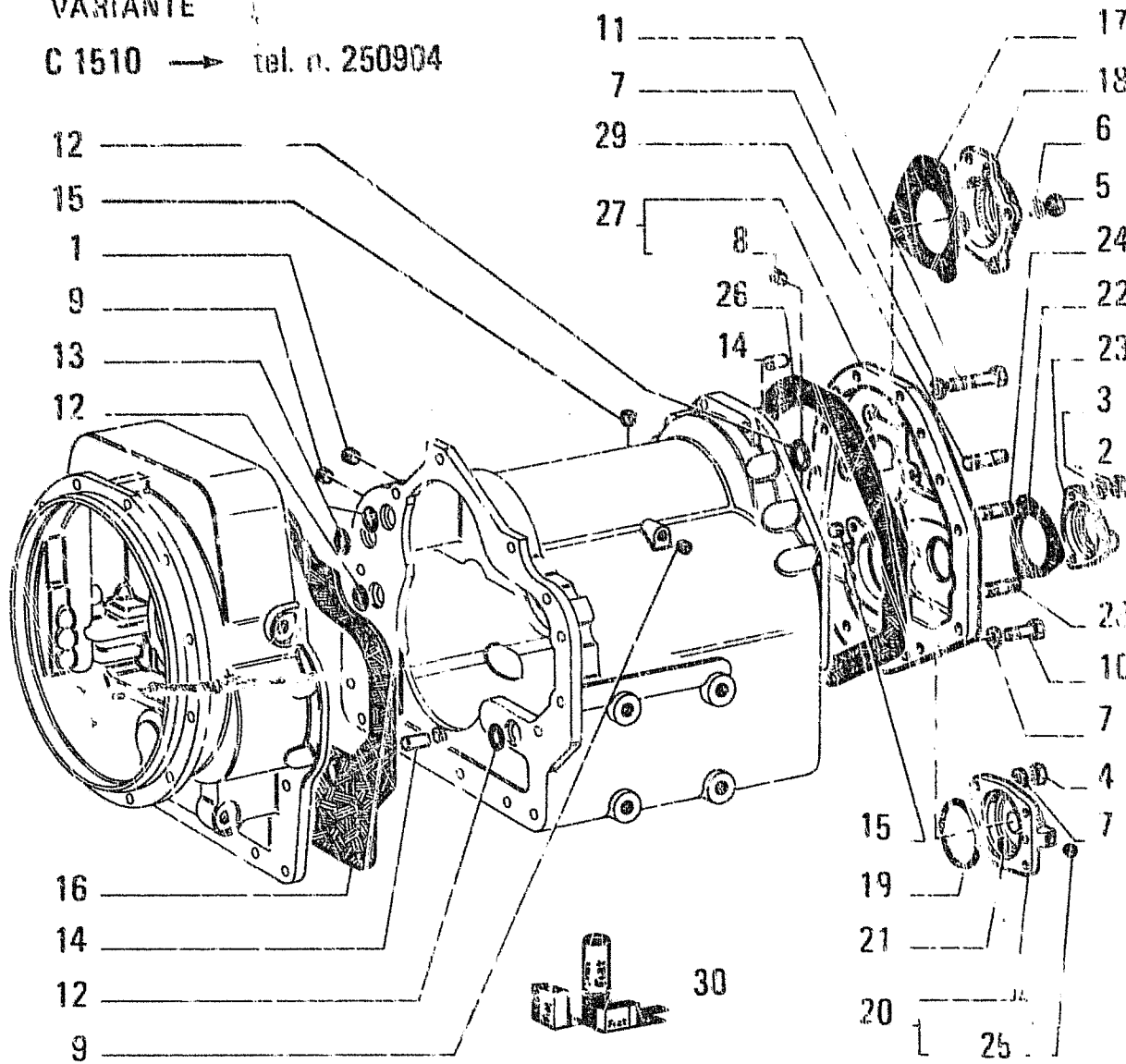

FIATALLIS FD7

B2.01/ 1 TAV. 4 PAG.1

QTY	PART NUMBER	TRANS CODE	DESCRIPTION	DESCRIZIONE
1	70673860	50T PLUG	TAPPO	
3	70910123	10D NUT	DADO	
3	8273916	131R WASHER	ROSETTA	
4	70910986	10D NUT	DADO	
4	70911331	10D NUT	DADO	
4	70912433	131R WASHER	ROSETTA	
19	70314678	131R WASHER	ROSETTA	
1	70917673	50T PLUG	TAPPO	
2	70918850	50T PLUG	TAPPO	
5	70921569	40V SCREW	VITE	
9	70927583	46V SCREW	VITE	
3	14462080	158G O-RING 3,55x20,22	GUARNIZIONE O-R 3,55x20,22	
2	14457130	156G O-RING 2,62x13,94	GUARNIZIONE O-R 2,62x13,94	
3	71004838	80P PIN	PERNO	
2	73066768	50T PLUG	TAPPO	
1	73118040	123G SEAL ASSY	GUARNIZIONE TENUTA FRONTALE	
1	79030211	123G SEAL ASSY	GUARNIZIONE TENUTA FRONTALE	
1	79030212	265C COVER	COFFRICHIO	
1	79030215	158G O-RING	GUARNIZIONE O-R	
1	79030216	265C COVER - ASSEMBLY	COFFRICHIO - COMPLETO	
1	79030217	158G O-RING	GUARNIZIONE O-R	
1	79030220	123G SEAL ASSY	GUARNIZIONE TENUTA FRONTALE	
1	79030221	265C COVER	COFFRICHIO	
3	79030224	210P STUD	PRIGONIERI	
1	79030241	50T PLUG	TAPPO	
1	79030266	123G SEAL ASSY	GUARNIZIONE TENUTA FRONTALE	
1	79030267	265C COVER - ASSEMBLY	COFFRICHIO - COMPLETO	

79028189

9

TRANSMISSION - CAMBIO DI VELOCITA' - BOITE DE VITESSES - WECHSELGETRIEBE - CAMBIO DE VELOCIDADES

B2.01/1 4
N.T.R. 191 - 20.0.1990
604.01.031.04

C1510 → tel. n. 250904

OPTIONAL
VARIANTE 30.0289 02.1

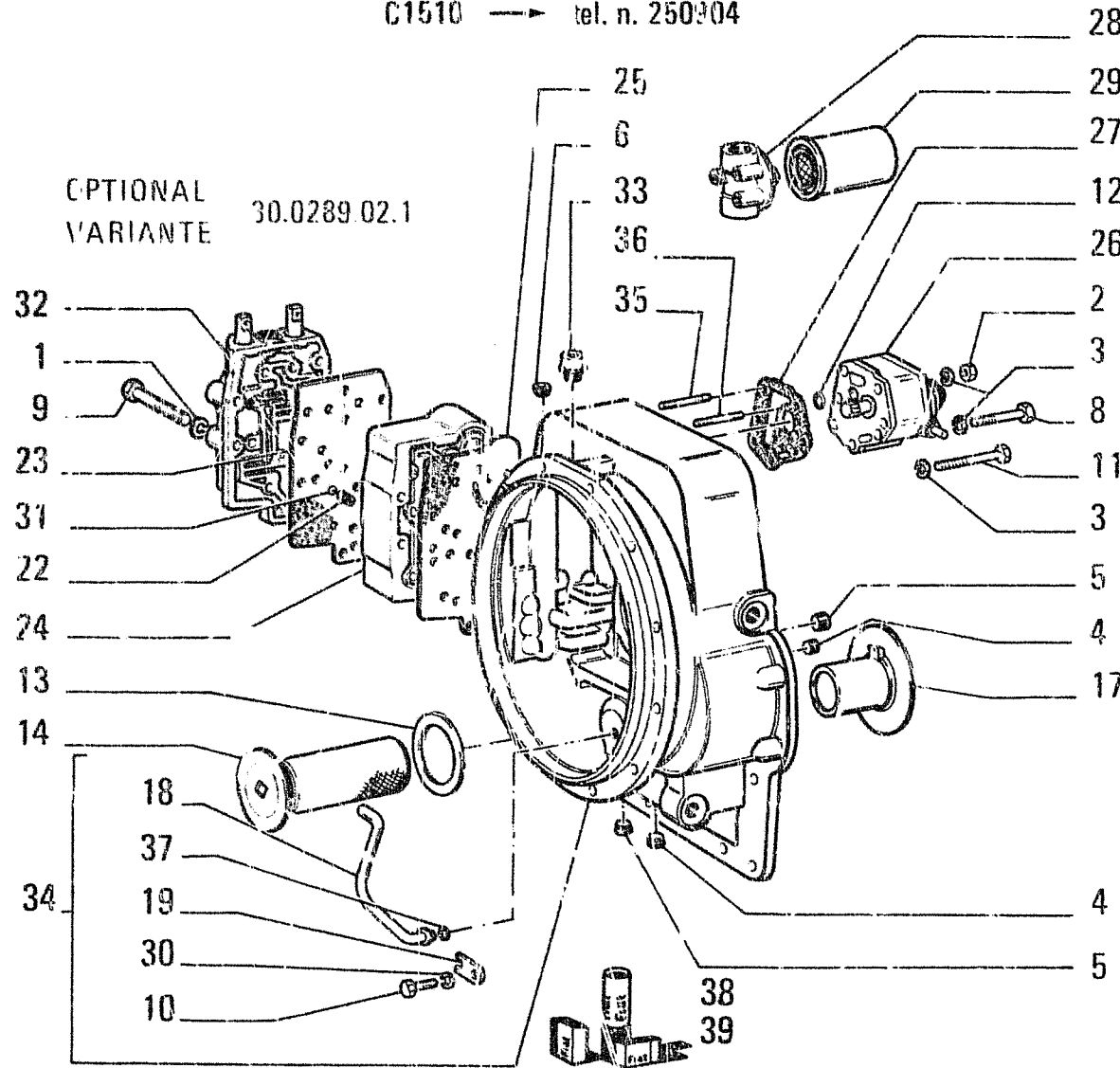

ITEM	PART NUMBER	QTY	TRANS CODE	DESCRIPTION	DESCRIZIONE
30	10571779	1	131R	WASHER 8,1x2	ROSETTA 8 1x2
32	7903026	1	83D	CONTROL VALVE - ASSEMBLY SEE SGR. B2 33	DISTRIBUTORE - COMPLETO VEDERE SGR. B2 33
33	7903026	1	50T	PLUG	TAPPO
34	7903026	1	35S	CASE - ASSEMBLY	SCATOLA - COMPLETO
35	7903099	1	210P	STUD	PIGIONE
36	7903100	1	210P	STUD	PIGIONE
37	79031003	1	158G	O-RING	GUARNIZIONE O-R
38	7905159	1	1K	KIT SEE PAGE 9	KIT VED. PAG. 9
39	7905160	1	1K	KIT SEE PAGE 9	KIT VED. PAG. 9

79028189

TRANSMISSION - CAMBIO DI VELOCITA' - BOITE DE VITESSES - WECHSELGETRIEBE -
CAMBIO DE VELOCIDADES

9 B2.01/1 3
N.T.R. 191-20.02.1990
G04.01.'81.04

C1510 → tel. n. 250904

OPTIONAL
VARIANTE 30 0289.02.1

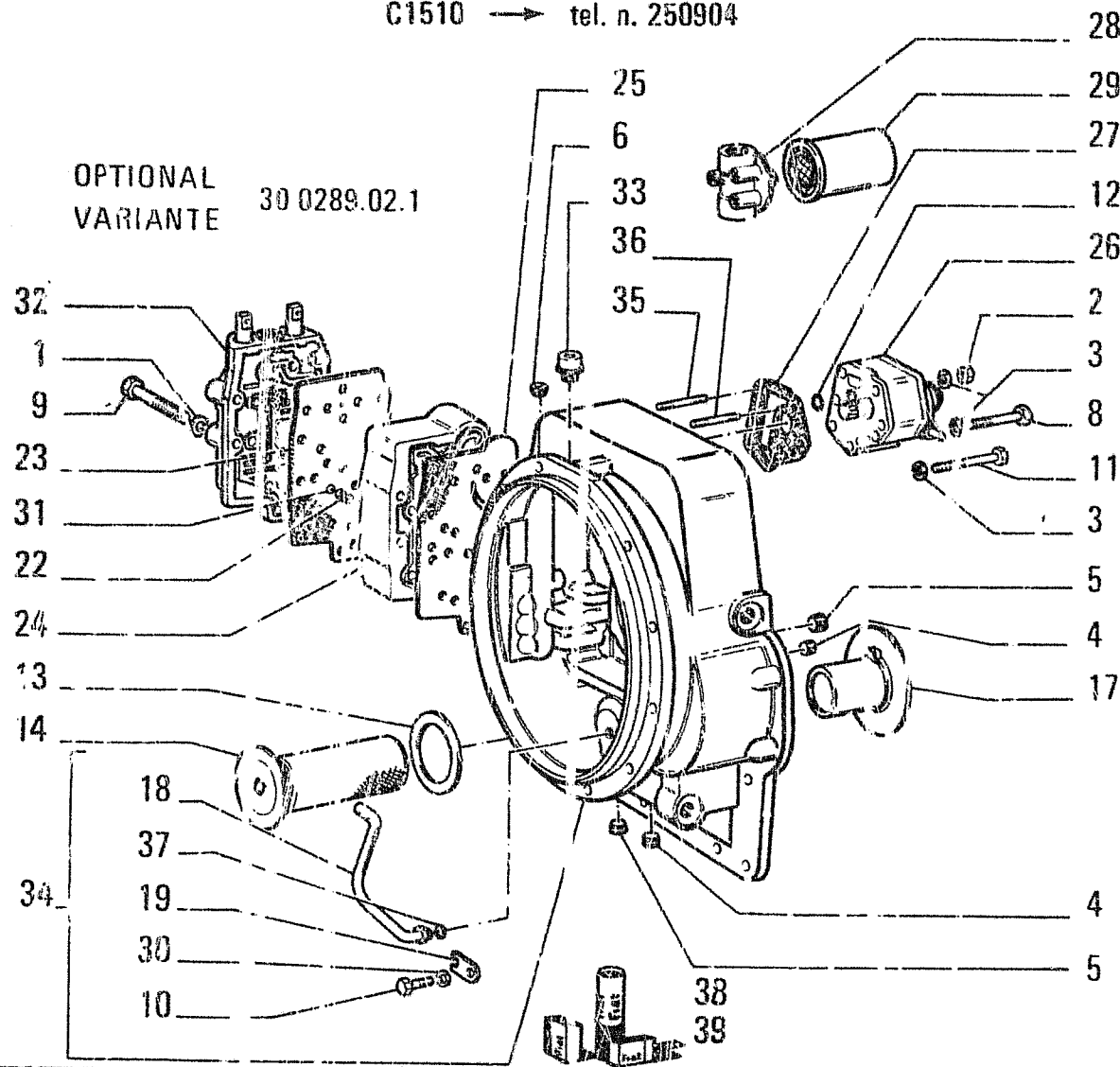

I T E M	PAR NUMBER	Q T Y	TRANS CODE	DESCRIPTION	DESCRIZIONE
1	8273916	9	131R	WASHER	ROSETTA
2	70910986	2	10D	NUT	DADO
3	70914678	1	131R	WASHER	ROSETTA
4	70917673	2	50T	PLUG	TAPPO
5	70917970	2	50T	PLUG	TAPPO
6	70918850	1	50T	PLUG	TAPPO
8	70925821	2	40V	SCREW	VITE
9	70927536	9	40V	SCREW	VITE
10	70927612	1	40V	SCREW	VITE
11	70928527	1	40V	SCREW	VITE
12	14457180	1	158G	O-RING 2.62x13.94	GUARNIZIONE O-R 2.62x13.94
13	71004848	1	123G	SEAL ASSY	GUARNIZIONE TENUTA FRONTALE
14	71004849	1	65F	FILTER	FILTRO
17	73118039	1	135M	HUE	MOZZO
18	73118053	1	193T	TUBE	TUBO RIGIDO
19	73118054	1	45F	CLIP	FERMAGLIO
22	73118121	2	100M	SPRING	MOLLA
23	73118122	1	123G	SEAL ASSY C2911	GUARNIZIONE TENUTA FRONTALE C2911
	79086375	1	122G	SEAL D2911	GUARNIZIONE D2911
24	73118123	1	10V	VALVE - ASSEMBLY SEE SGR. B2.34	VALVOLA - COMPLETO VEDERE SGR. B2.34
25	73118124	1	123G	SEAL ASSY	GUARNIZIONE TENUTA FRONTALE
26	73118126	1	155P	PUMP	POMPA
27	73118127	1	123G	SEAL ASSY	GUARNIZIONE TENUTA FRONTALE
28	73118170	1	300C	SUPPORT	SUPPORTO
29	73118171	1	65F	FILTER	FILTRO

79028189

TRANSMISSION - CAMBIO DI VELOCITA' - BOITE DE VITESSES - WECHSELGETRIEBE -
CAMBIO DE VELOCIDADES

9

B2.01 1 3

N.T.R. 191 - 20.12.1990

604.01.081.04

C1510 → tel. n. 250904

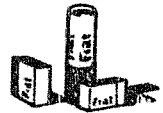
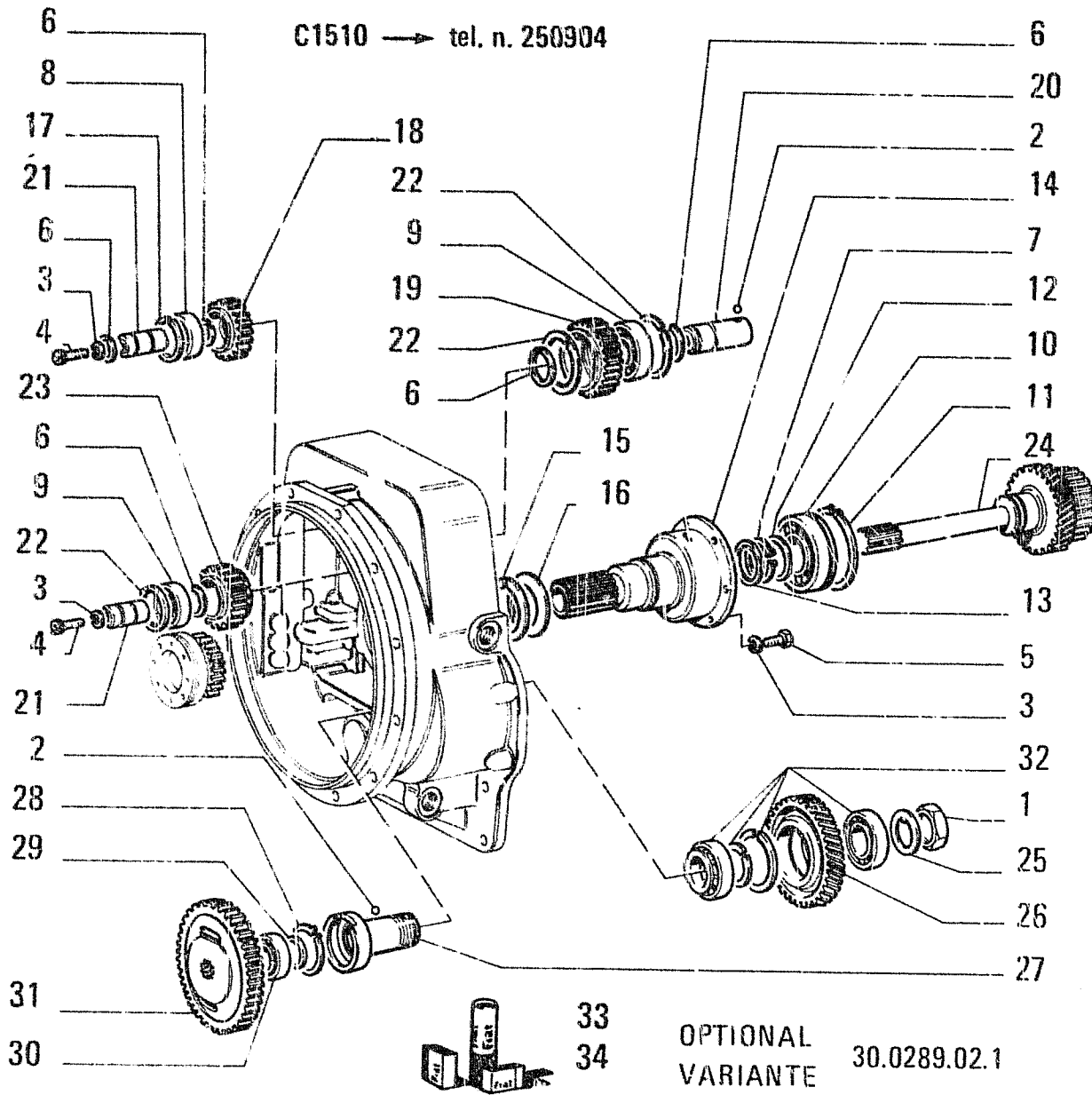

33
34
OPTIONAL
VARIANTE 30.0289.02.1

FIATALLIS FD7

ITEM	PART NUMBER	QTY	TRANS CODE	DESCRIPTION	DESCRIZIONE
26	79030248	1	50I GEAR		INGRANAGGIO
27	79030249	1	16A SHAFT		ALBERO
28	79030250	1	51A LOCKRING		ANELLO DI SICUREZZA
29	79030251	1	45A RING		ANELLO
30	79030252	1	341C BEARING		CUSCINETTO
31	79030253	1	50I GEAR		INGRANAGGIO
32	79030261	1	341C BEARING		CUSCINETTO
33	79055159	1	1K KIT SEE PAGE 9		KIT VED. PAG.9
34	79055160	1	1K KIT SEE PAGE 9		KIT VED. PAG.9

79028189
TRANSMISSION - CAMBIO DI VELOCITA' - BOITE DE VITESSES - WECHSELGETRIEBE - CAMBIO DE VELOCIDADES

9
B2.01/1 2
N.T.R. 200 - 15.10.1990
604.01.081.05

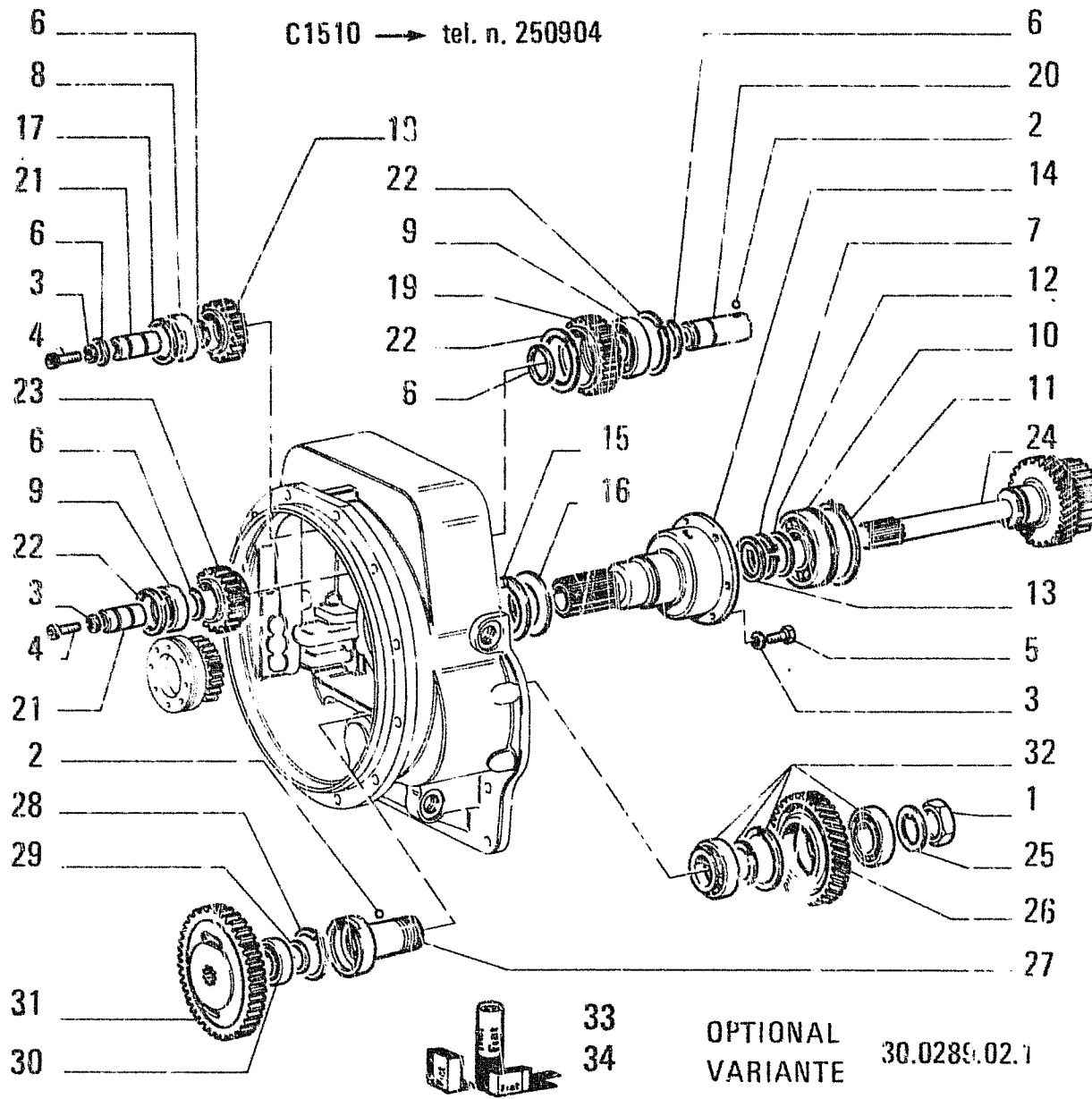

FIAT LUIS FD7

92.01/ 1 TAV. 2 PAG.1

ITEM	PART NUMBER	QTY	TRANS CODE	DESCRIPTION	DESCRIZIONE
1	70059946	1	10D NUT	DADO	
2	70673856	2	140S BALL	SFERA	
3	8273916	10	131R WASHER	ROSETTA	
4	70921076	4	40V SCREW	VITE	
5	70922763	6	40V SCREW	VITE	
6	70929166	5	45A RING	ANELLO	
7	73116957	1	51A LOCKRING	ANELLO DI SICUREZZA	
8	73116959	1	341C BEARING	CUSCINETTO	
9	73116971	2	341C BEARING	CUSCINETTO	
10	73132932	1	341C BEARING	CUSCINETTO	
11	73118057	1	51A LOCKRING	ANELLO DI SICUREZZA	
12	73118058	2	131R WASHER	ROSETTA	
13	73118059	1	45A RING	ANELLO	
14	73118060	1	300S SUPPORT C3213	SUPPORTO C3213	
	79059927	1	300S SUPPORT D3213	SUPPORTO D3213	
15	73118061	1	45A RING C2911	ANELLO C2911	
	79064451	1	45A RING D2911	ANELLO D2911	
16	73118062	1	100M SPRING	MOLLA	
17	73118080	1	45A RING	ANELLO	
18	73118081	1	50I GEAR	INGRANAGGIO	
19	73118082	1	50I GEAR	INGRANAGGIO	
20	73118083	1	16A SHAFT	ALBERO	
21	73118262	2	300S SUPPORT	SUPPORTO	
22	73118320	3	45A RING	ANELLO	
23	79030242	1	50I GEAR	INGRANAGGIO	
24	79030246	1	16A SHAFT	ALBERO	
25	79030247	2	131R WASHER	ROSETTA	

TRANSMISSION - CAMBIO DI VELOCITA' - BOITE DE VITESSES - WECHSELGETRIEBE - CAMBIO DE VELOCIDADES

79028189

9

B2.01/1

2

N.T.R. 200 - 15.10.1990

604.01.081.05

S6

OPTIONAL
VARIANTE

30.0289.02.1

C 1510 → tel. n. 250904

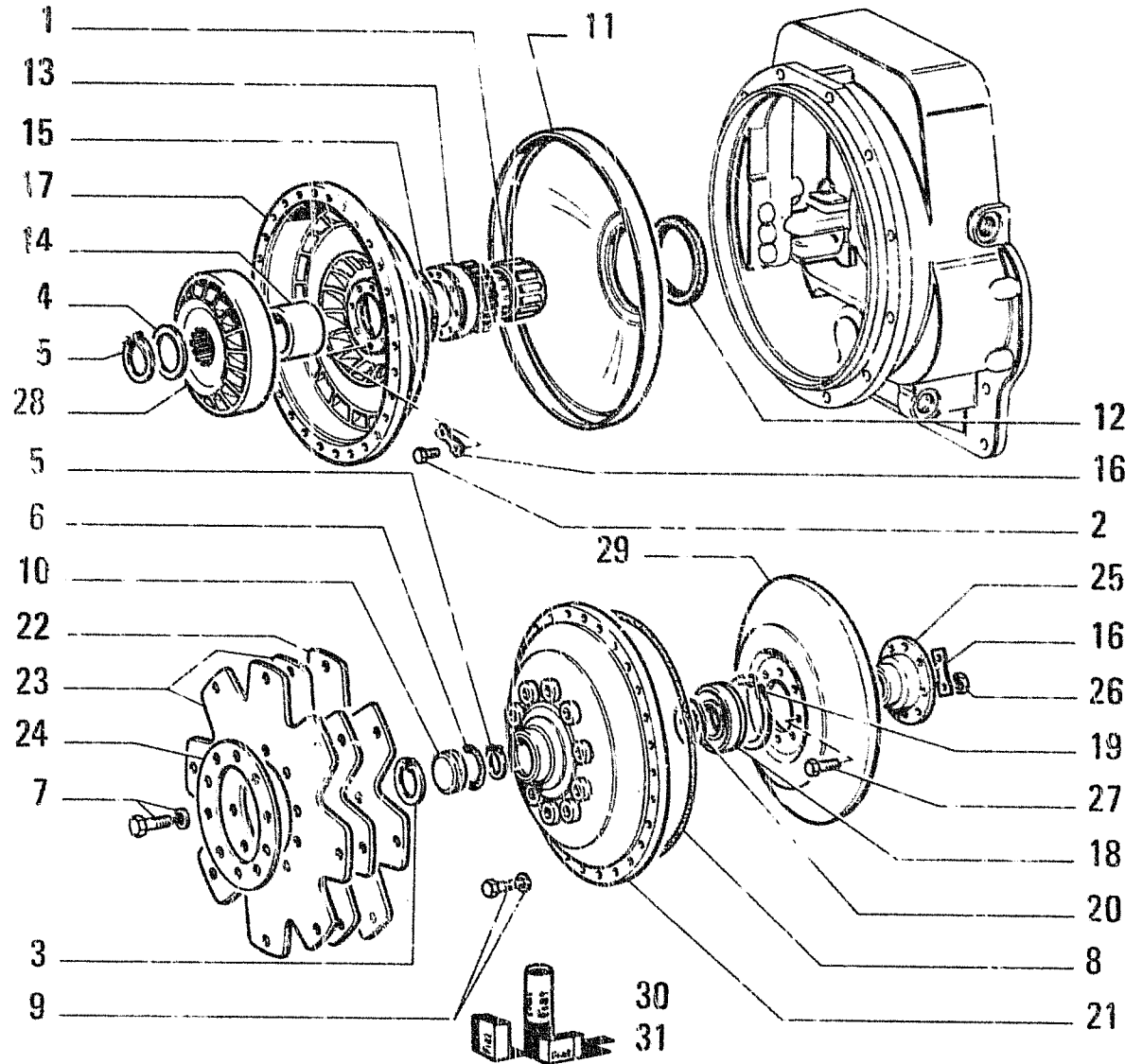

FIATALLIS FD7

B2.01/ 1 TAV. 1 PAG.2

ITEM	PART NUMBER	QTY	TRANS CODE	DESCRIPTION	DESCRIZIONE
28	79031238	1	271S	STATOR	STATORE
29	79031239	1	60G	IMPELLER	GIRANTE
30	79055159	1	1K	KIT SEE PAGE 9	KIT VED. PAG.9
31	79055160	1	1K	KIT SEE PAGE 9	KIT VED. PAG.9

79028189

9

TRANSMISSION - CAMBIO DI VELOCITA' - BOITE DE VITESSES - WECHSELGETRIEBE - CAMBIO DE VELOCIDADES

B2.01/1

1

N.T.R. 191 - 20.02.1990

604.01.081.04

S7

OPTIONAL
VARIANTE 30 0289 02 1

C 1510 → tel. n. 250904

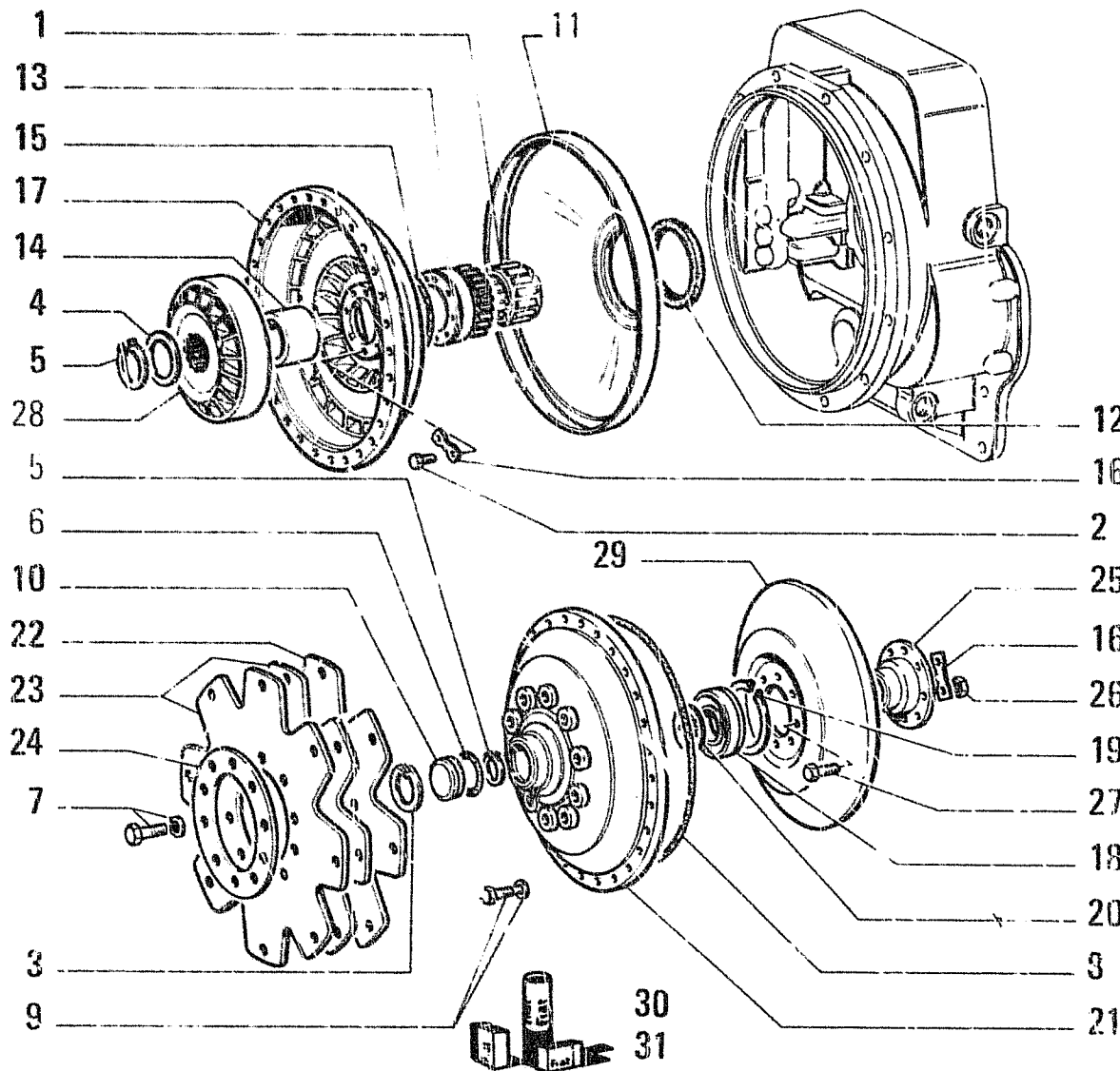

FIATALLIS FD7

B2.01/ 1 TAV. 1 PAG.1

ITEM	PART NUMBER	QTY	TRANS CODE	DESCRIPTION	DESCRIZIONE
1	70673970	1	341C	BEARING	CUSCINETTO
2	70927211	8	40V	SCREW	VITE
3	70935974	1	51A	LOCKRING	ANELLO DI SICUREZZA
4	70927747	1	45A	RING	ANELLO
5	70928720	2	51A	LOCKRING	ANELLO DI SICUREZZA
6	14458580	1	153G	O-RING 2,62x36,17	GUARNIZIONE O-R 2,62x36,17
7	71004835	10	44V	SCREW AND WASHER ASSY	VITE CON ROSETTA
8	71005536	1	153G	O-RING	GUARNIZIONE O-R
9	71008465	24	44V	SCREW AND WASHER ASSY	VITE CON ROSETTA
10	73117963	1	50T	PLUG	TAPPO
11	73118063	1	20D	DEFLECTOR	DEFLETTORE
12	73118064	1	123C	SEAL ASSY	GUARNIZIONE TENUTA FRONTALE
13	73118065	1	50I	GEAR	INGRANAGGIO
14	73118066	1	75D	SPACER	DISTANZIALE
15	73118067	1	158G	O-RING	GUARNIZIONE O-R
16	73118068	8	110P	PLAQUE	PIASTRINA
17	73118069	1	60G	IMPELLER	GIRANTE
18	73118072	1	341C	BEARING	CUSCINETTO
19	73118073	1	51A	LOCKRING	ANELLO DI SICUREZZA
20	73118074	1	131R	WASHER	ROSETTA
21	73132674	1	265C	COVER	COPERCHIO
22	73118173	1	75M	DIAPHRAGM	MEMBRANA
23	73118174	2	75M	DIAPHRAGM	MEMBRANA
24	73118175	1	45A	RING	ANELLO
25	79030255	1	135K	HUB	MOZZO
26	79030256	8	10D	NUT	DADO
27	79030257	8	40V	SCREW	VITE

79028189

TRANSMISSION - CAMBIO DI VELOCITA' - BOITE DE VITESSES - WECHSELGETRIEBE - CAMBIO DE VELOCIDADES

9

B2.01 1 1

N.T.R. 205 - 30.09.1991

604.01.001.06

D1510 tel. n. 25030E →

REVERSE SECOND AND LOW SPEED GEAR
 RETROMARCIA, 2a e 1a MARCIA

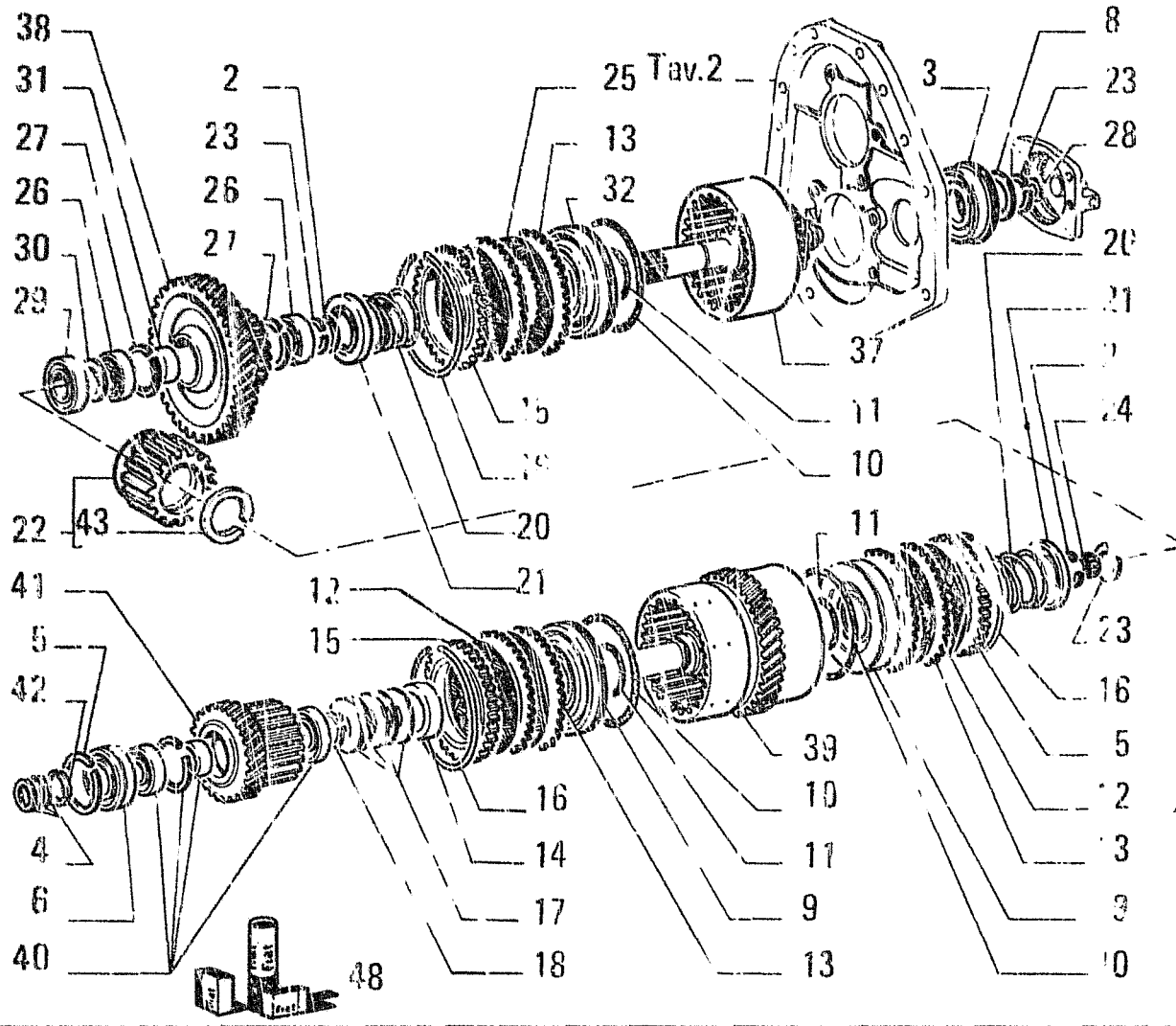

ITEM	PART NUMBER	QTY	TRANS CODE	DESCRIPTION	DESCRIZIONE
30	73118138	1	75D	SPACER	DISTANZIALE
31	73118139	1	75D	SPACER	DISTANZIALE
32	73118236	1	110P	PLUNGER	PISTONINO
37	79030228	1	16A	SHAFT	ALBERO
38	79060006	1	10I	GEAR	INGRANAGGIO
39	79065194	1	16A	SHAFT	ALBERO
40	79030234	1	341C	BEARING	CUSCINETTO
41	79060008	1	10I	GEAR	INGRANAGGIO
42	79030236		191S	SHIM	SPESSORE
	79030237		191S	SHIM	SPESSORE
	79030238		195S	SHIM	SPESSORE
	79030239		195S	SHIM	SPESSORE
	79030240		193S	SHIM	SPESSORE
43	79064449	1	51A	LOCKRING	ANELLO DI SICUREZZA
48	79055160	1	1K	KIT SEE PAGE 9	KIT VED. PAG.9

79064265

TRANSMISSION -- CAMBIO DI VELOCITA' -- BOITE DE VITESSES -- WECHSELGETRIEBE -- CAMBIO DE VELOCIDADES

9

B2.01 / B

11

N.T.R. 205 - 30.09.1991
 604.01.001.06

D1510 tel. n. 250905 →

REVERSE, SECOND AND LOW SPEED GEAR
RETROMARCIA, 2a e 1a MARCIA

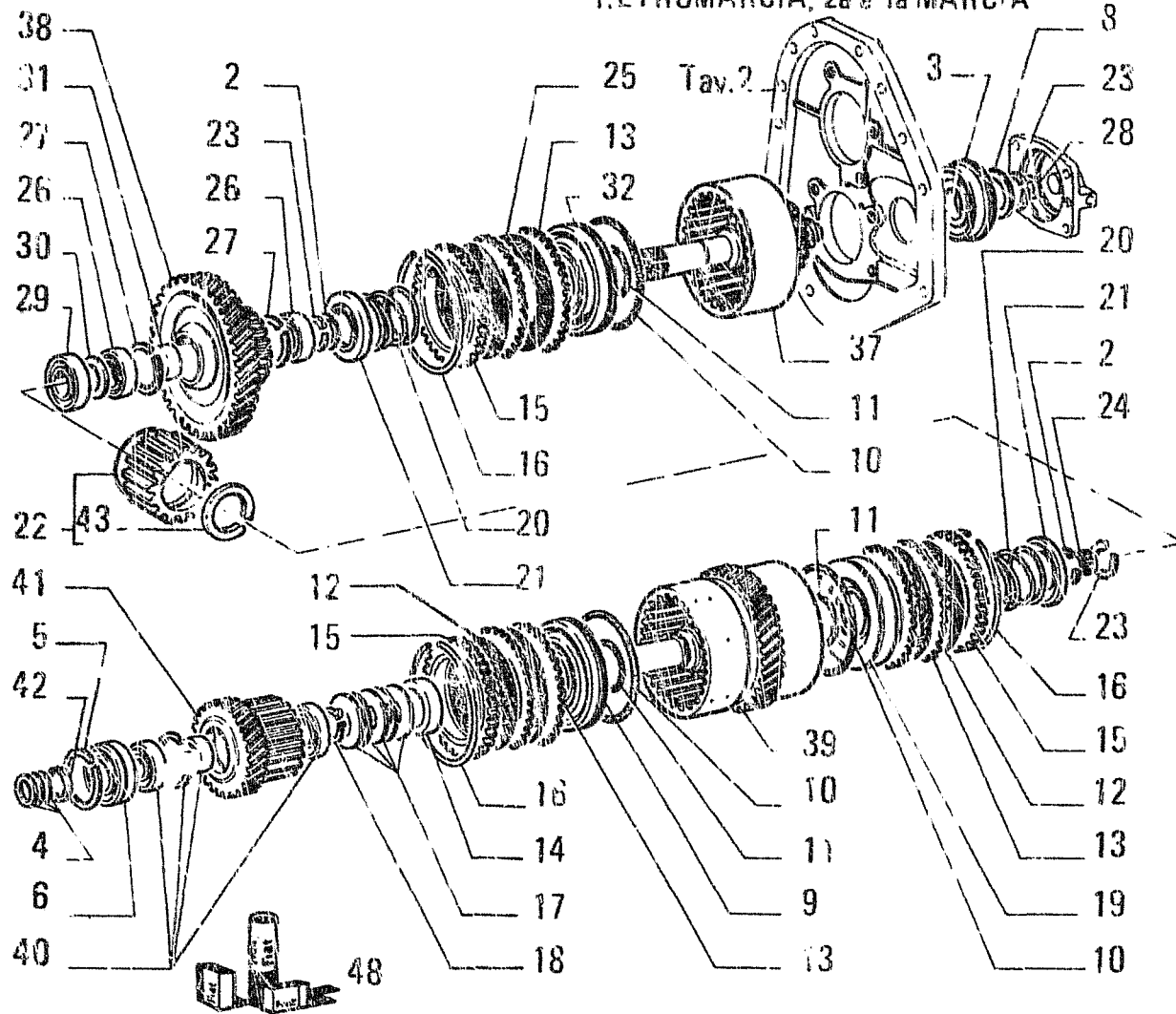

FIATALLIS FD7

B2.01/ B TAV.11 PAG.1

ITEM	PART NUMBER	QTY	TRANS CODE	DESCRIPTION	DESCRIZIONE
2	70926000	2	51A	LOCKRING	ANELLO DI SICUREZZA
3	73132784	1	341C	BEARING	CUSCINETTO
4	71004926	3	45A	RING	ANELLO
5	71004961	1	51A	LOCKRING	ANELLO DI SICUREZZA
6	71004962	1	341C	BEARING	CUSCINETTO
8	73118058	1	131R	WASHER	ROSETTA
9	73118065	1	130P	PLUNGER	PISTONCINO
10	73118086	3	123G	SEAL ASSY	GUARNIZIONE TENUTA FRONTALE
11	73118087	3	123G	SEAL ASSY	GUARNIZIONE TENUTA FRONTALE
12	73118088	14	60D	DISC	DISCO
13	73118089	22	60D	DISC	DISCO
14	73118090	1	75D	SPACER	DISTANZIALE
15	73118091	3	60D	DISC	DISCO
16	73118092	3	45A	RING	ANELLO
17	73118093	5	100M	SPRING	MOLLA
18	73118094	1	51A	LOCKRING	ANELLO DI SICUREZZA
19	73118106	1	130P	PLUNGER	PISTONCINO
20	73118107	2	100M	SPRING	MOLLA
21	73118108	2	60S	CUP	SCODELLINO
22	79052636	1	135M	HUB - ASSEMBLY	MOZZO - COMPLETO
23	73118110	3	51A	LOCKRING	ANELLO DI SICUREZZA
24	73118111	1	341C	BEARING	CUSCINETTO
25	73118133	8	60D	DISC	DISCO
26	73118134	2	341C	BEARING	CUSCINETTO
27	73118135	2	51A	LOCKRING	ANELLO DI SICUREZZA
28	73118136	1	45A	RING	ANELLO
29	73118137	1	341C	BEARING	CUSCINETTO

73.064265

9

TRANSMISSION - CAMBIO DI VELOCITA' - BOITE DE VITESSES - WECHSELGETRIEBE - CAMBIO DE VELOCIDADES

B2.01/B

11

N.T.R. 205 - 30.09.1991

604.01.081.06

S10

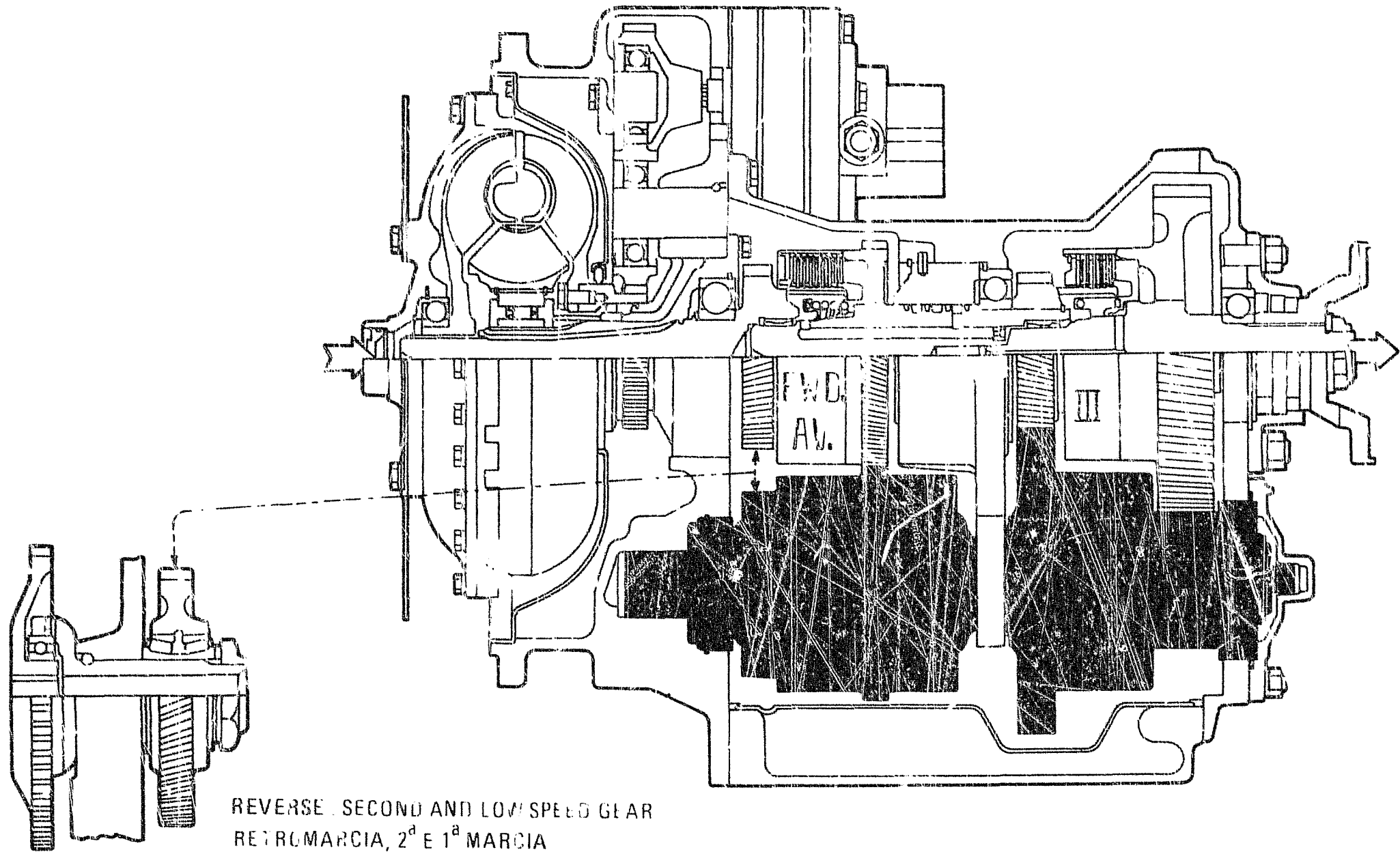

75064/55

TRANSMISSION - CAMBIO DI VELOCITA' - BOITE DE VITESSES - WECHSELGETRIEBE - CAMBIO DE VELOCIDADES

B2.01/B

10

N.T.R. 205 - 30.09.1991
604.01.081.06

S11

D1510 tel. n. 250905 →

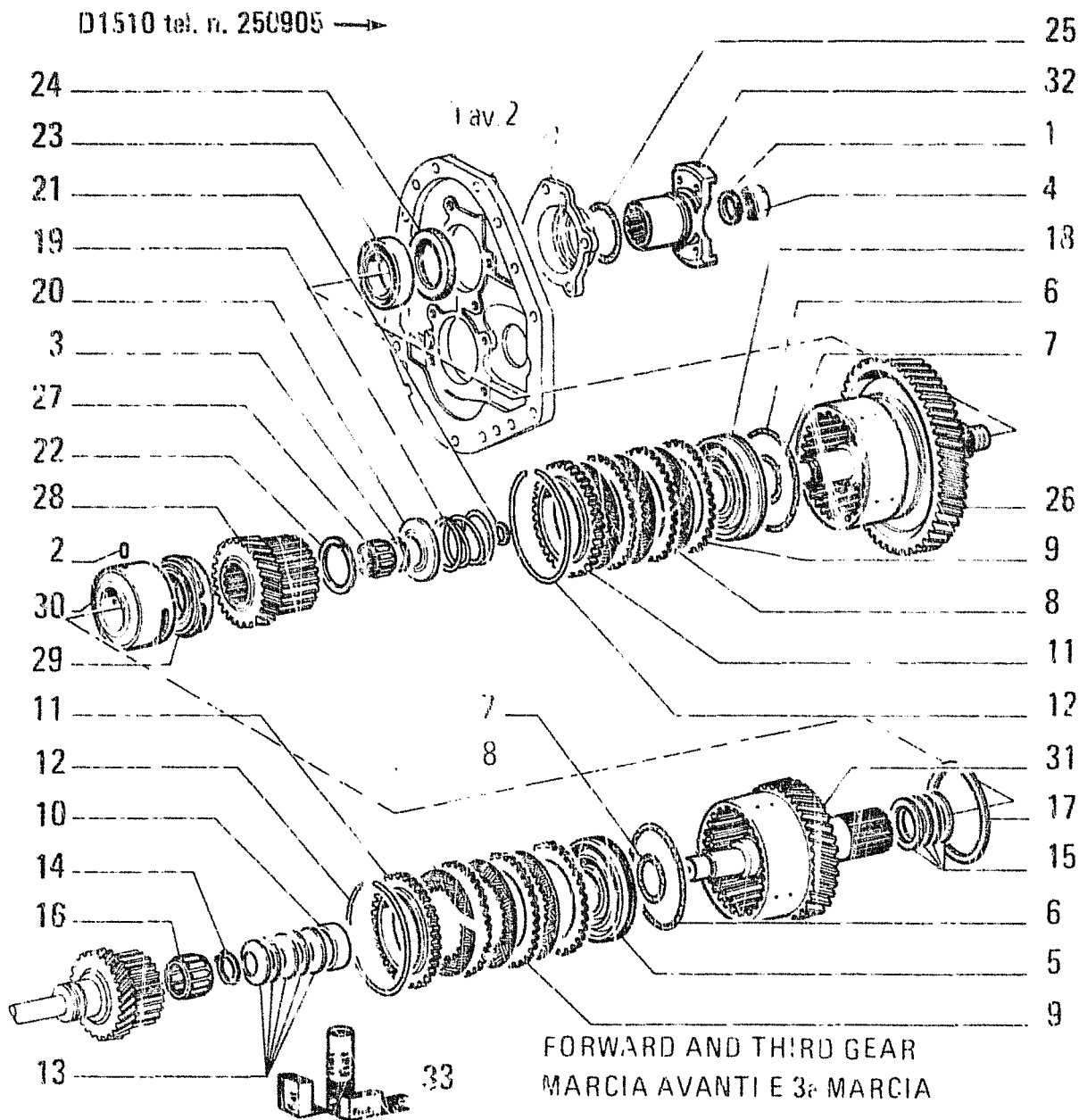

FIATALLIS F67

B2 01 B TAV. 9 PAG.2

ITEM	PART NUMBER	QTY	TRANS CODE	DESCRIPTION	DESCRIZIONE
28	79060005	1	50	GEAR	INGRANAIGIO
29	79030230	1	341	BEARING	CUSCINETTO
30	79064245	1	131M	HUB	MOZZO
31	79030232	1	16A	SHAFT	ALBERO
32	79031240	1	71F	FLANGE	FLANGIA
33	79055160	1	1K	KIT SEE PAGE 9	KIT VE. PAG.9

79064265

TRANSMISSION - CAMBIO DI VELOCITA' - BOITE DE VITESSES - WECHSELGETRIEBE - CAMBIO DE VELOCIDADES

B2.01 / B 9

N.T.N. 205 - 30.09.1991
604.01.081.06

D1510 tel. n. 250905 →

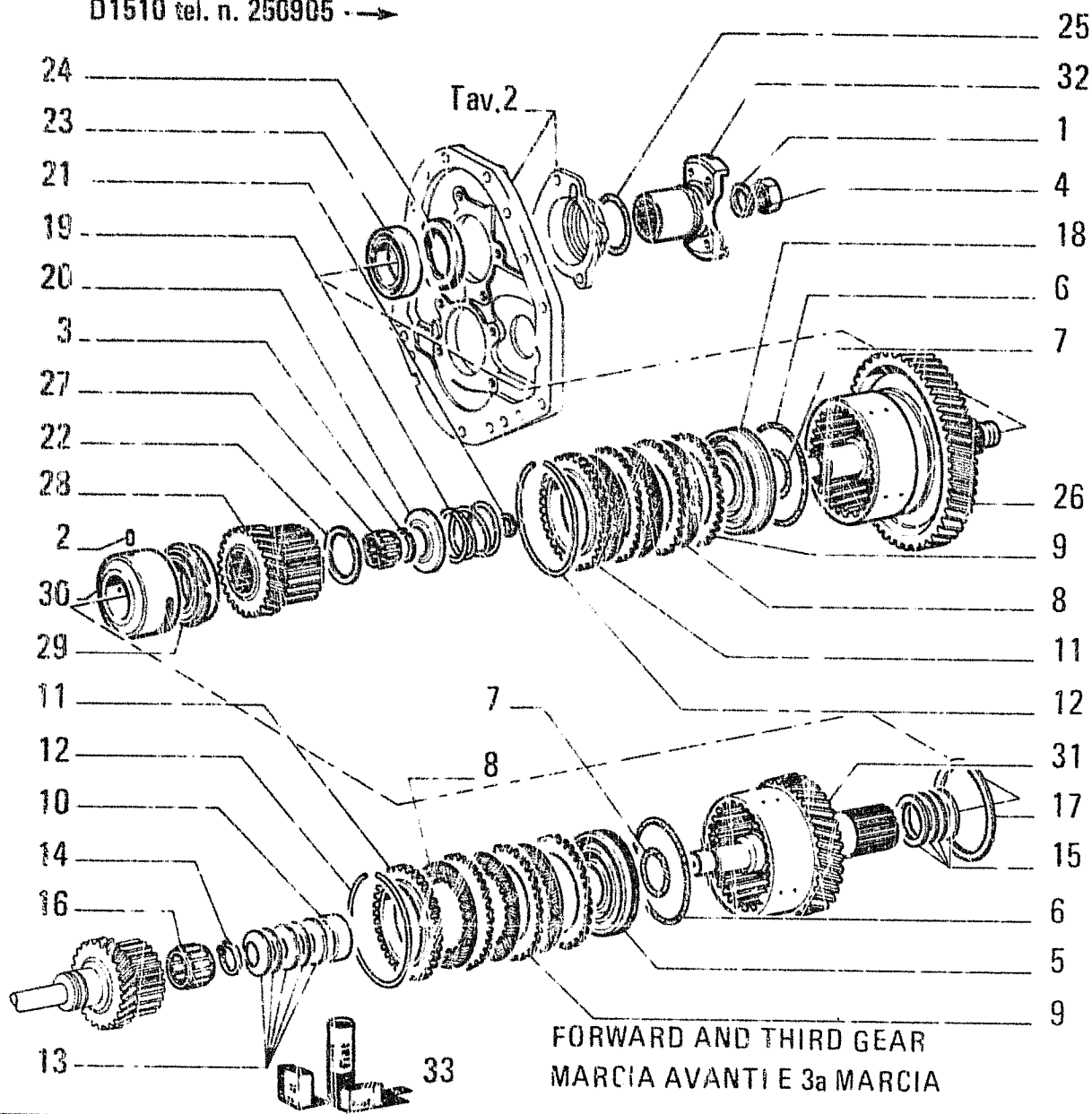

FORWARD AND THIRD GEAR
MARCIA AVANTI E 3a MARCIA

79064265

FIATALLIS FD7

F 2.01/ B TAV. 9 PAC 1

ITEM	PART NUMBER	QTY	TRANS CODE	DESCRIPTION	DESCRIZIONE
1	70673871	1	131R	WASHER	ROSETTA
2	79063942	1	80P	PIN	PERNO
3	70926000	1	51A	LOCKRING	ANELLO DI SICUREZZA
4	73109871	1	10D	NUT	DADO
5	73118085	1	130P	PLUNGER	PISTONCINO
6	73118086	2	123G	SEAL ASSY	GUARNIZIONE TENUTA FRONTALE
7	73118087	2	123G	SEAL ASSY	GUARNIZIONE TENUTA FRONTALE
8	73118088	14	60D	DISC	DISCO
9	73118089	14	60D	DISC	DISCO
10	73118090	1	75D	SPACER	DISTANZIALE
11	73118091	2	60D	DISC	DISCO
12	73118092	2	45A	RING	ANELLO
13	73118093	5	100M	SPRING	MOLLA
14	73118094	1	51A	LOCKRING	ANELLO DI SICUREZZA
15	73118096	4	45A	RING	ANELLO
16	73118097	1	341C	BEARING	CUSCINETTO
17	73118098	1	51A	LOCKRING	ANELLO DI SICUREZZA
18	73118106	1	130P	PLUNGER	PISTONCINO
19	73118107	1	100M	SPRING	MOLLA
20	73118108	1	60S	CUP	SCODELLINO
21	73118136	1	45A	RING	ANELLO
22	79051090	1	51A	LOCKRING	ANELLO DI SICUREZZA
23	79030209	1	341C	BEARING	CUSCINETTO
24	79030210	1	123G	SEAL ASSY	GUARNIZIONE TENUTA FRONTALE
25	14463880	1	158G	O-RING 3,53x34,52	GUARNIZIONE O-R 3,53x34,52
26	79030225	1	16A	SHAFT	ALBERO
27	79030226	1	341C	BEARING	CUSCINETTO

TRANSMISSION - CAMBIO DI VELOCITA' - BOITE DE VITESSES - WECHSELGETRIEBE - CAMBIO DE VELOCIDADES

9
B2.01/B 9
N.T. A. 205 - 30.09.1991
604.01.081.06

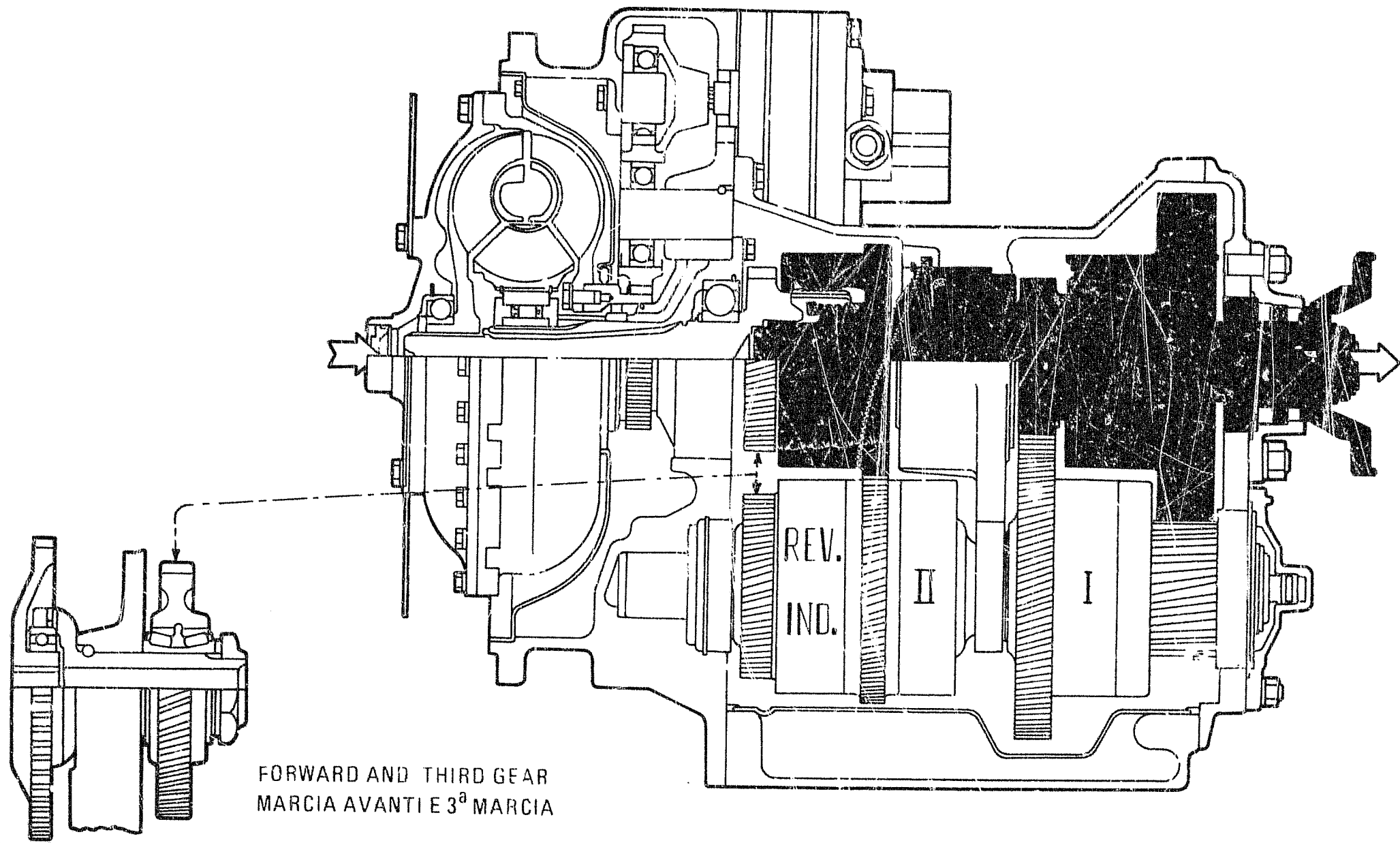

FORWARD AND THIRD GEAR
MARCIA AVANTI E 3ª MARCIA

79064265

TRANSMISSION - CAMBIO DI VELOCITA' - BOITE DE VITESSES - WECHSELGETRIEBE - CAMBIO DE VELOCIDADES

B2.01/B

8

N.T.R. 205 - 30.09.1991
604.01.081.06

S14

D1510 tel. n. 250905 →

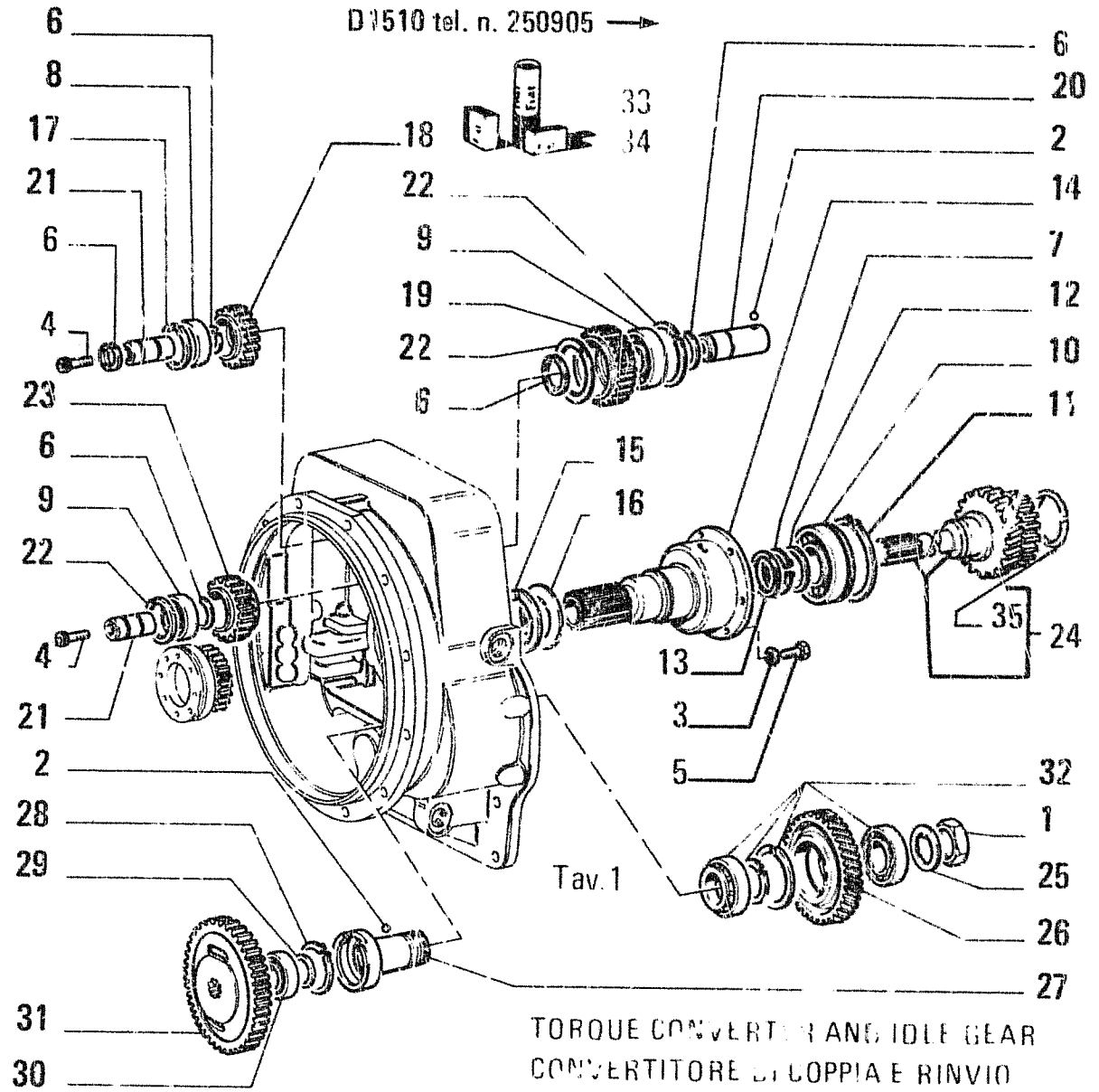

TORQUE CONVERTER AND IDLE GEAR
 CONVERTITORE DI COPPIA E RINVIO

FIATALLIS F07

B2.01/ B TAV. 7 PAG.2

ITEM	PART NUMBER	QTY	TRANS CODE	DESCRIPTION	DESCRIZIONE
26	79030248	1	50I GEAR		INGRANAGGIO
27	79030249	1	16A SHAFT		ALBERO
28	79030250	1	51A LOCKRING		ANELLO DI SICUREZZA
29	79030251	1	45A RING		ANELLO
30	79030252	1	341C BEARING		CUSCINETTO
31	79030253	1	50I GEAR		INGRANAGGIO
32	79030261	1	341C BEARING		CUSCINETTO
33	79055159	1	1K KIT SEE PAGE 9		KIT VED. PAG 9
34	79055160	1	1K KIT SEE PAGE 9		KIT VED. PAG 9
35	79064449	1	51A LOCKRING		ANELLO DI SICUREZZA

79064265

TRANSMISSION - CAMBIO DI VELOCITA' - BOITE DE VITESSES - WECHSELGETRIEBE - CAMBIO DE VELOCIDADES

9

B2.01/B 7

N.T.R. 205 - 30.09.1991
 604.01.081.06

D1510 tel. n. 250905 →

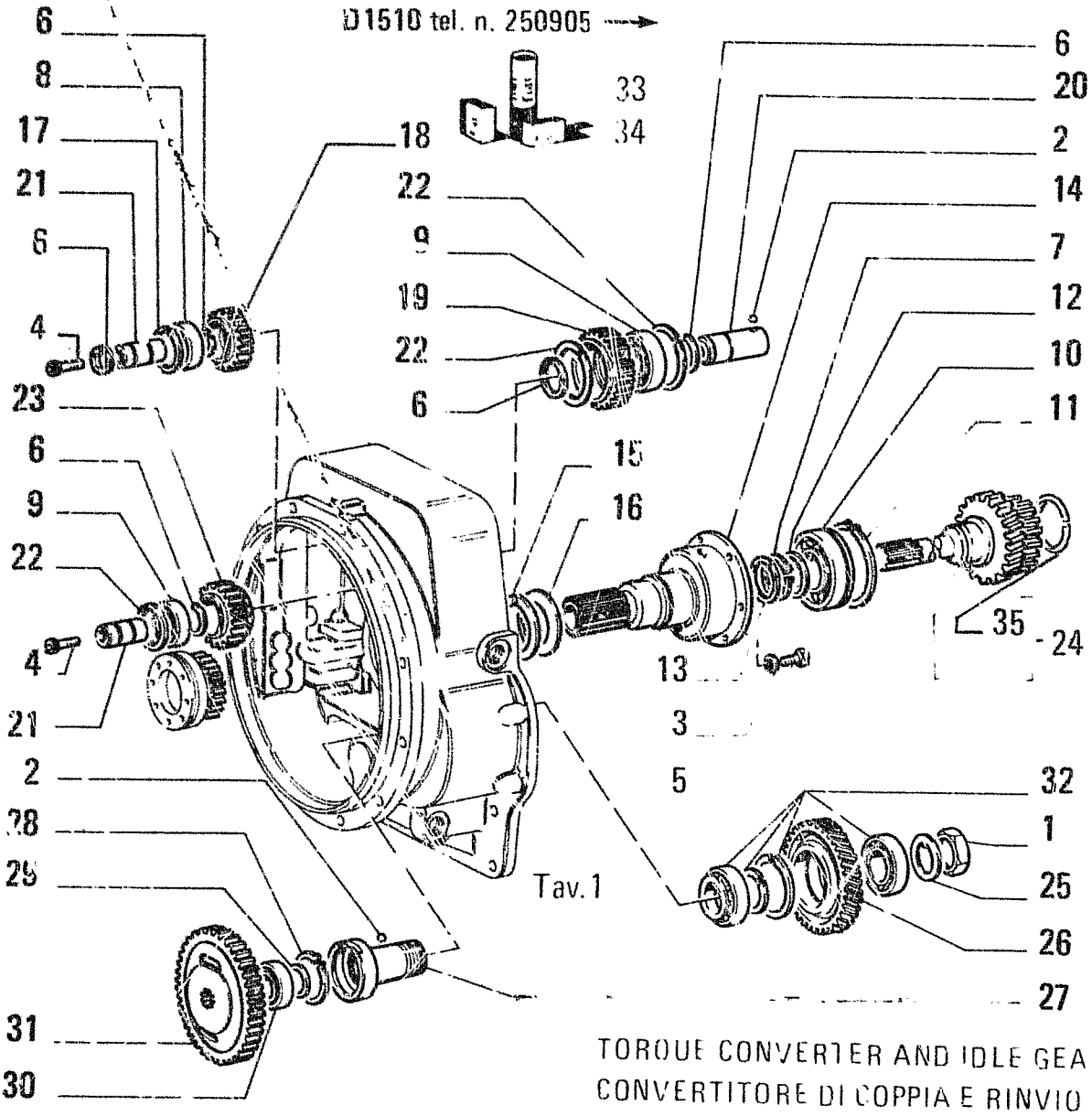

FIATALLIS FD7

B2.01/ B TAV. 7 PAG.1

ITEM	PART NUMBER	QTY	TRANS CODE	DESCRIPTION	DESCRIZIONE
1	70059946	1	10D NUT	DADO	
2	70673856	2	140S BALL	SFERA	
3	10516879	6	170R LOCKWASHER 10,2x2,5	ROSETTA EL 10,2x2,5	
4	70921076	4	40V SCREW	VITE	
5	70922763	6	40V SCREW	VITE	
6	70929166	5	45A RING	ANELLO	
7	73116957	1	51A LOCKRING	ANELLO DI SICUREZZA	
8	73116959	1	341C BEARING	CUSCINETTO	
9	73116971	2	341C BEARING C2950	CUSCINETTO C2950	
	79064455	2	341C BEARING D2950	CUSCINETTO D2950	
10	73132932	1	341C BEARING	CUSCINETTO	
11	73118057	1	51A LOCKRING	ANELLO DI SICUREZZA	
12	73118058	2	131R WASHER	ROSETTA	
13	73118059	1	45A RING	ANELLO	
14	79059927	1	300S SUPPORT	SUPPORTO	
15	73118061	1	45A RING C2911	ANELLO C2911	
	79064451	1	45A RING D2911	ANELLO D2911	
16	73118062	1	100M SPRING	MOLLA	
17	73118080	1	45A RING	ANELLO	
18	73118081	1	50I GEAR	INGRANAGGIO	
19	73118082	1	50I GEAR	INGRANAGGIO	
20	73118083	1	16A SHAFT	ALBERO	
21	73118262	2	300S SUPPORT	SUPPORTO	
22	73118320	3	45A RING	ANELLO	
23	79030242	1	50I GEAR	INGRANAGGIO	
24	79052635	1	16A SHAFT - ASSEMBLY	ALBERO - COMPLETO	
25	79030247	2	131R WASHER	ROSETTA	

79064265

TRANSMISSION - CAMBIO DI VELOCITA' - BOITE DE VITESSES - WECHSELGETRIEBE - CAMBIO DE VELOCIDADES

9

B2.01/B 7

N.T.R. 205 - 30.09.1991
 604.01.061.06

S16

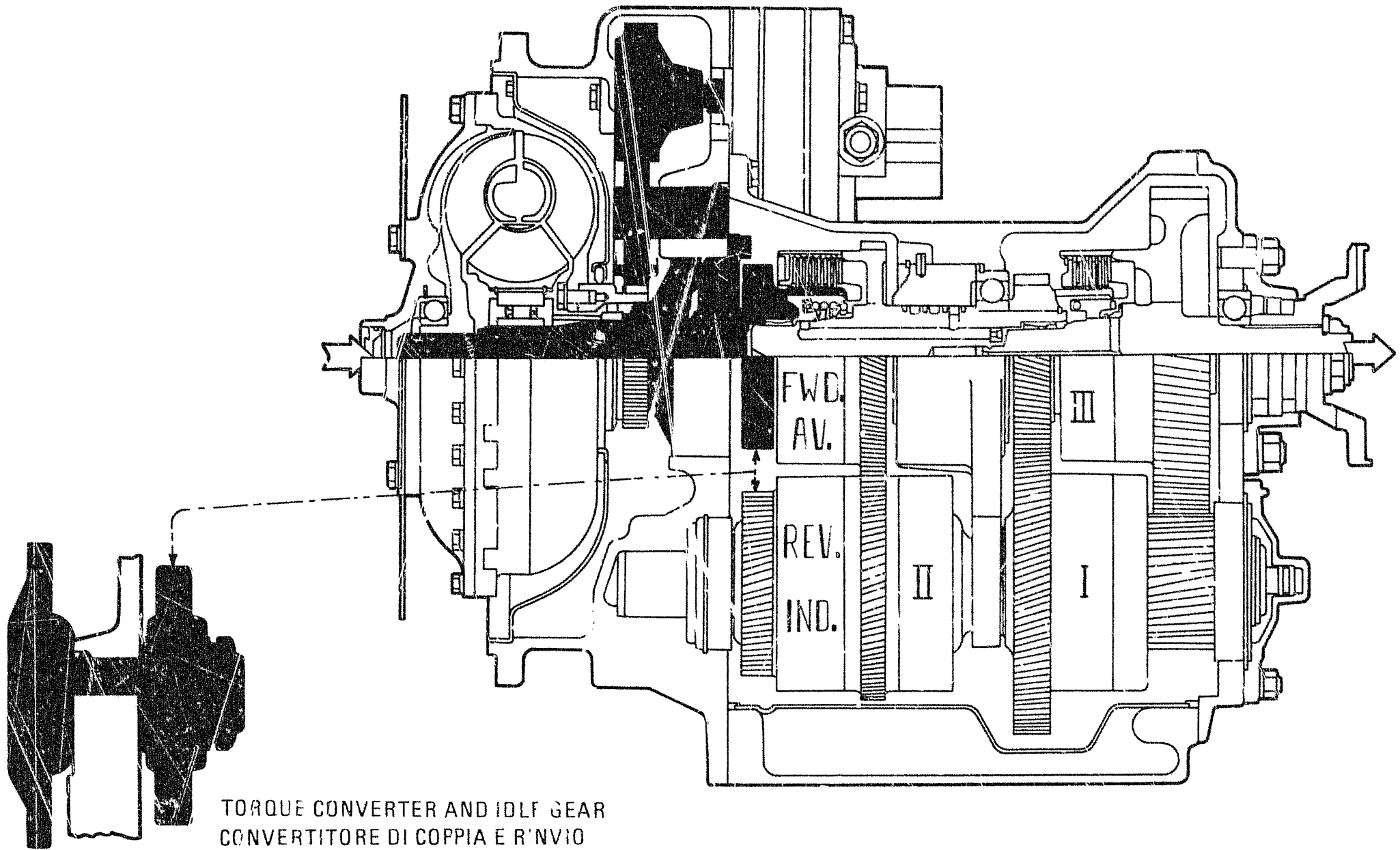

TORQUE CONVERTER AND IDLER GEAR
 CONVERTITORE DI COPPIA E RINVIO

79064265

B.2.01/B

6

TRANSMISSION - CAMBIO DI VELOCITA' - BOITE DE VITESSES - WECHSELGETRIEBE - CAMBIO DE VELOCIDADES

N.T.R. 205 - 30.09.1991

874.01.081.00

S17

B

MECHANICAL TRANSMISSION • CLUTCH • TRANSMISSION • TRANSMISSION SHAFT • AXLES
TRASMISSIONE MECCANICA • FRIZIONE • CAMBIO • ALBERO DI TRASMISSIONE • PONTI
TRANSMISSION MECANIQUE • EMBRAYAGE • BOITE DE VITESSES • ARBRE DE TRANSMISSION • PONTS
MECHANISCHE KRAFTÜBERTRAGUNG • KUPPLUNG • GETRIEBE • GELENKWELLE • ACHSEN
TRANSMISSION MECANICA • EMBRAGUE • CAMBIO • ARBOL DE TRANSMISSION • PUENTES

OPTIONAL
VARIANTE 39.0289.02.1

C 1510 → tel. n. 250904

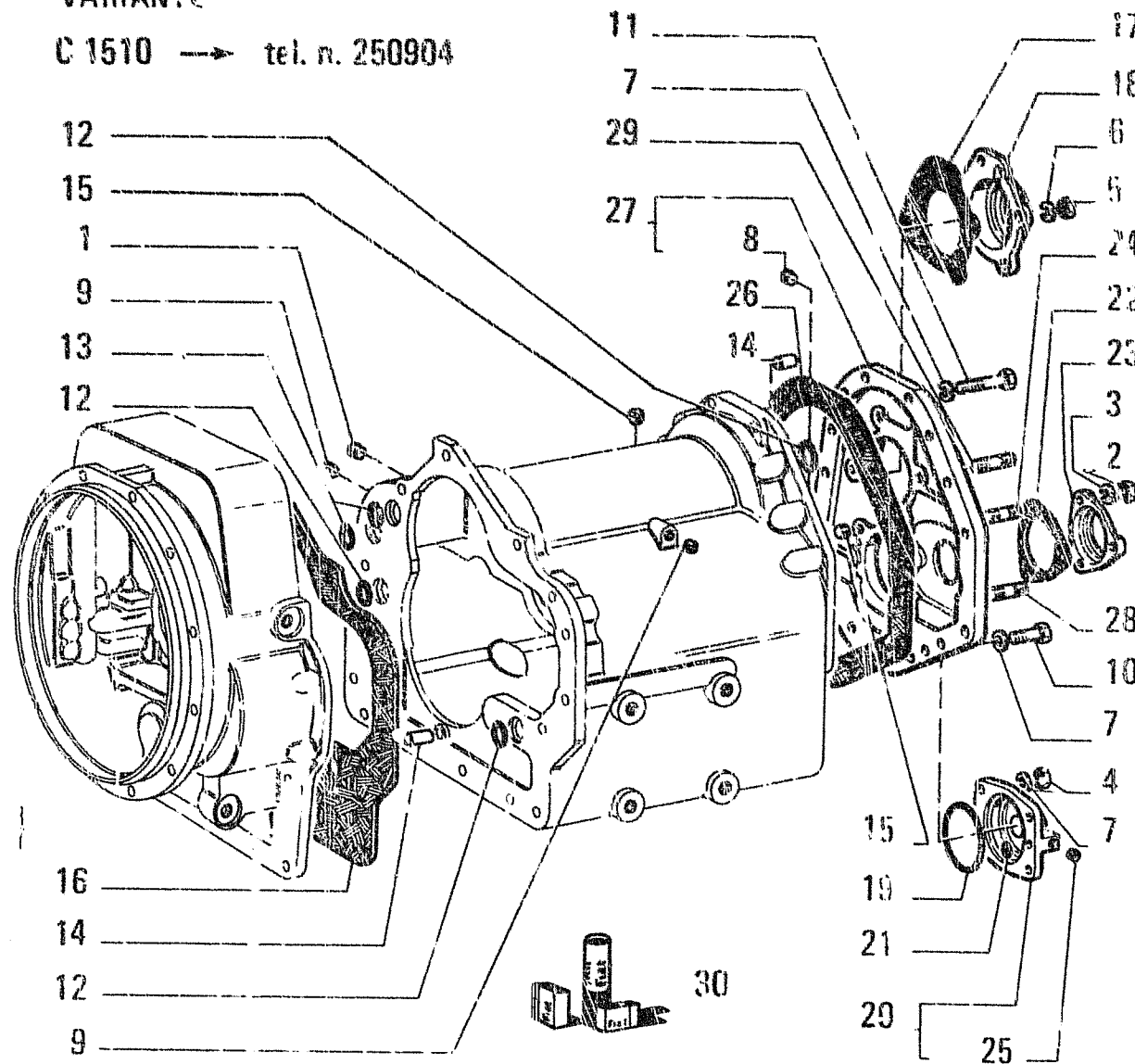

FIATALLIS FD7

B2.01/ 1 TAV. 4 PAG.2

ITEM	PART NUMBER	QTY	TRANS CODE	DESCRIPTION	DESCRIZIONE
28	79031001	4	210P STUD		PRIGIONIERO
29	79031002	4	210P STUD		PRIGIONIERO
30	79055160	1	1K KIT SEE PAGE 9		KIT VED. PAG 9

79028189

TRANSMISSION - CAMBIO DI VELOCITA' - BOITE DE VITESSES - WECHSELGETRIEBE - CAMBIO DE VELOCIDADES

9

B2.01/1

4

N.T.R. 191 - 20.02.1990

604.01.001.04

T2

OPTIONAL
VARIANTE 30.0289 02 1

C1510 → tel. n. 250904

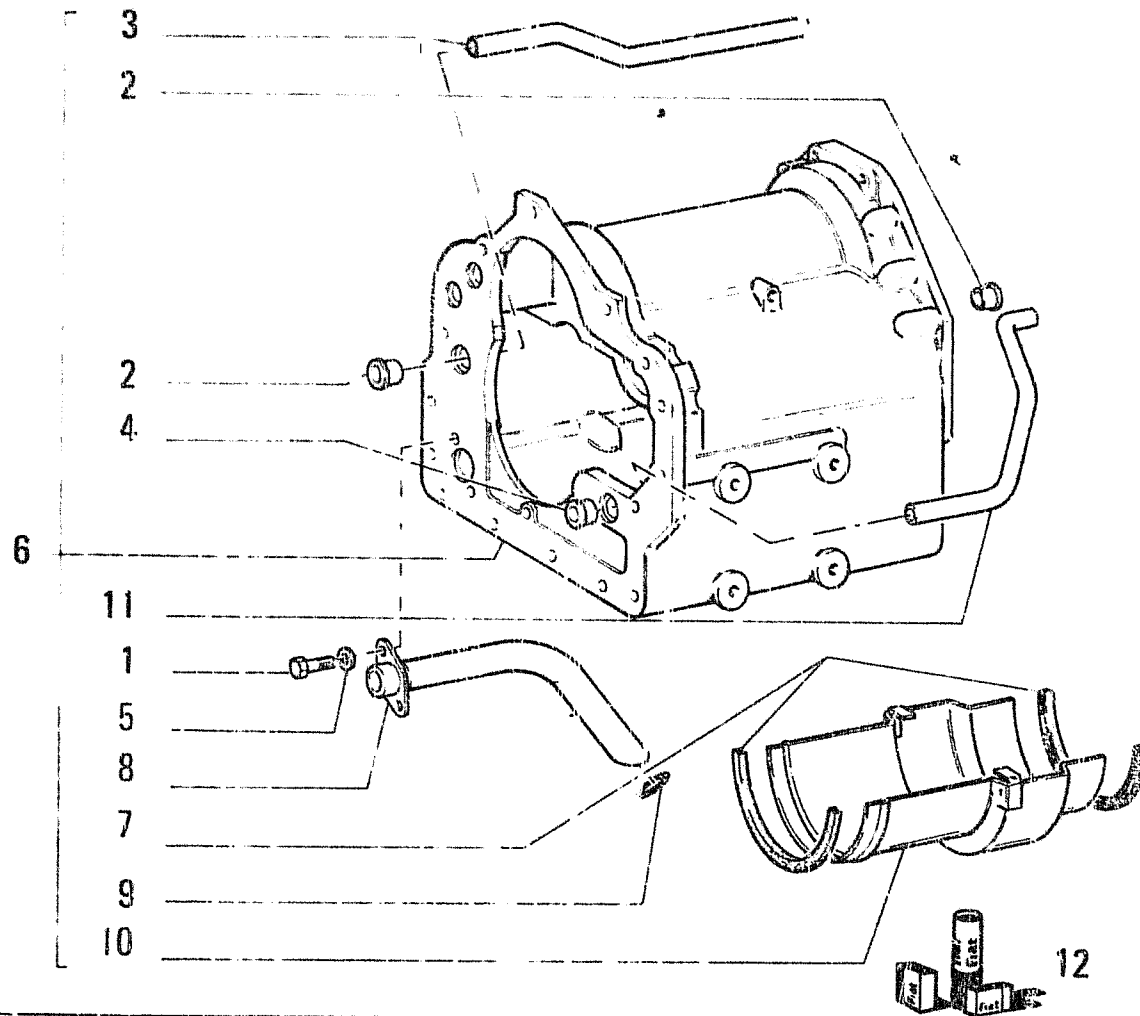

ITEM	PART NUMBER	QTY	TRANS CODE	DESCRIPTION	DESCRIZIONE
1	70927612	2		4V SCREW	VITE
2	71004820	2		135M HUB	MOZZO
3	73118043	1		193T TUBE	TUBO RIGIDO
4	73118044	1		135M HUB	MOZZO
5	10571779	2		131R WASHER 8.1x2	ROSETTA 8.1x2
6	79030265	1		35S CASE - ASSEMBLY	SCATOLA - COMPLETO
7	79030268	2		123G SEAL ASSY	GUARNIZIONE TENUTA FRONTALE
8	79030269	1		193T TUBE	TUBO RIGIDO
9	79030270	1		158G O-RING	GUARNIZIONE O-R
10	79030271	1		20D DEFLECTOR	DEFLETTORE
11	79030277	1		193T TUBE	TUBO RIGIDO
12	79055160	1		PK KIT SEE PAGE 9	KIT VED. PAG. 9

79028139

TRANSMISSION -- CAMBIO DI VELOCITA' -- BOITE DE VITESSES -- WECHSELGETRIEBE -- CAMBIO DE VELOCIDADES

9

B2.01/1

5

N.T.R. 191 - 20.02.1990

604.01.081.04

T3

C1510 → tel. n. 250904

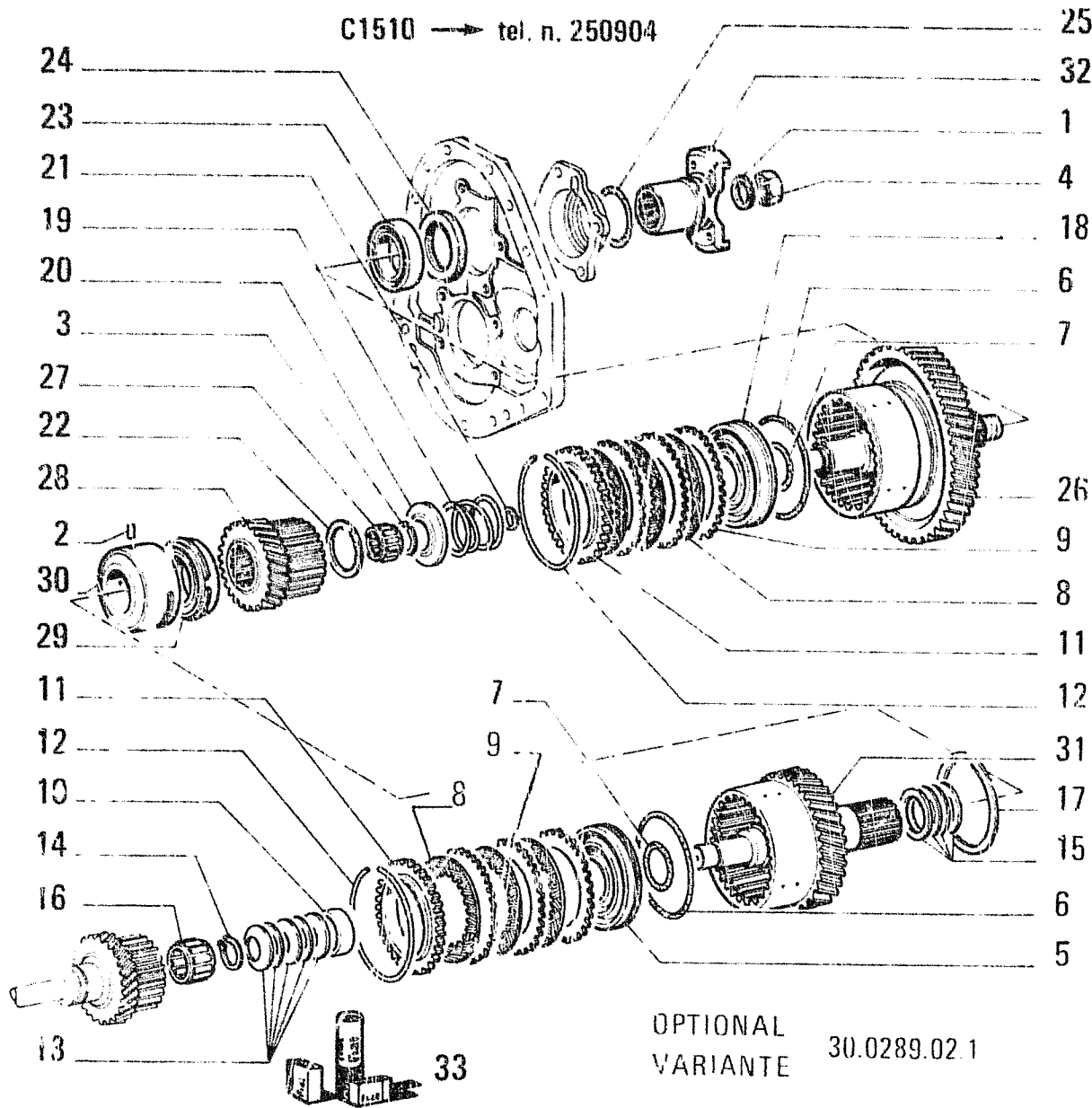

FIATALLIS FD7

FI2.01/ 1 TAV. 6 PAG.1

ITEM	PART NUMBER	QTY	TRANS CODE	DESCRIPTION	DESCRIZIONE
1	70673871	1	131R	WASHER	ROSETTA
2	14603470	1	80P	PIN 6x16	PERNO 6x16
3	70926000	1	51A	LOCKRING	ANELLO DI SICUREZZA
4	73109871	1	10D	NUT	DADO
5	73118085	1	130P	PLUNGER	PISTONCINO
6	73118086	2	123G	SEAL ASSY	GUARNIZIONE TENUTA FRONTALE
7	73118087	2	123C	SEAL ASSY	GUARNIZIONE TENUTA FRONTALE
8	73118088	14	60D	DISC	DISCO
9	73118089	14	60D	DISC	DISCO
10	73118090	1	75D	SPACER	DISANZIALE
11	73118091	2	60D	DISC	DISCO
12	73118092	2	45A	RING	ANELLO
13	73118093	5	100M	SPRING	MOLLA
14	73118094	1	51A	LOCKRING	ANELLO DI SICUREZZA
15	73118096	4	45A	RING	ANELLO
16	73118097	1	341C	BEARING	CUSCINETTO
17	73118098	1	51A	LOCKRING	ANELLO DI SICUREZZA
18	73118106	1	130P	PLUNGER	PISTONCINO
19	73118107	1	100M	SPRING	MOLLA
20	73118108	1	60S	CUP	SCODELLINO
21	73118136	1	45A	RING	ANELLO
22	73118369	1	51A	LOCKRING	ANELLO DI SICUREZZA
23	79030209	1	341C	BEARING	CUSCINETTO
24	79030210	1	123G	SEAL ASSY	GUARNIZIONE TENUTA FRONTALE
25	14463880	1	158G	O-RING 3,53x34,52	GUARNIZIONE O-R 3,53x34,52
26	79030225	1	16A	SHAFT	ALBERO
27	79030226	1	341C	BEARING	CUSCINETTO

OPTIONAL VARIANTE 30.0289.02.1

79028189
 TRANSMISSION - CAMBIO DI VELOCITA' - BOITE DE VITESSES - WECHSELGETRIEBE - CAMBIO DE VELOCIDADES

9
 B2.01/1 6
 N.T.R. 191 - 20.02.1990
 604.01.081.04

C1510 → tel. n. 2-0904

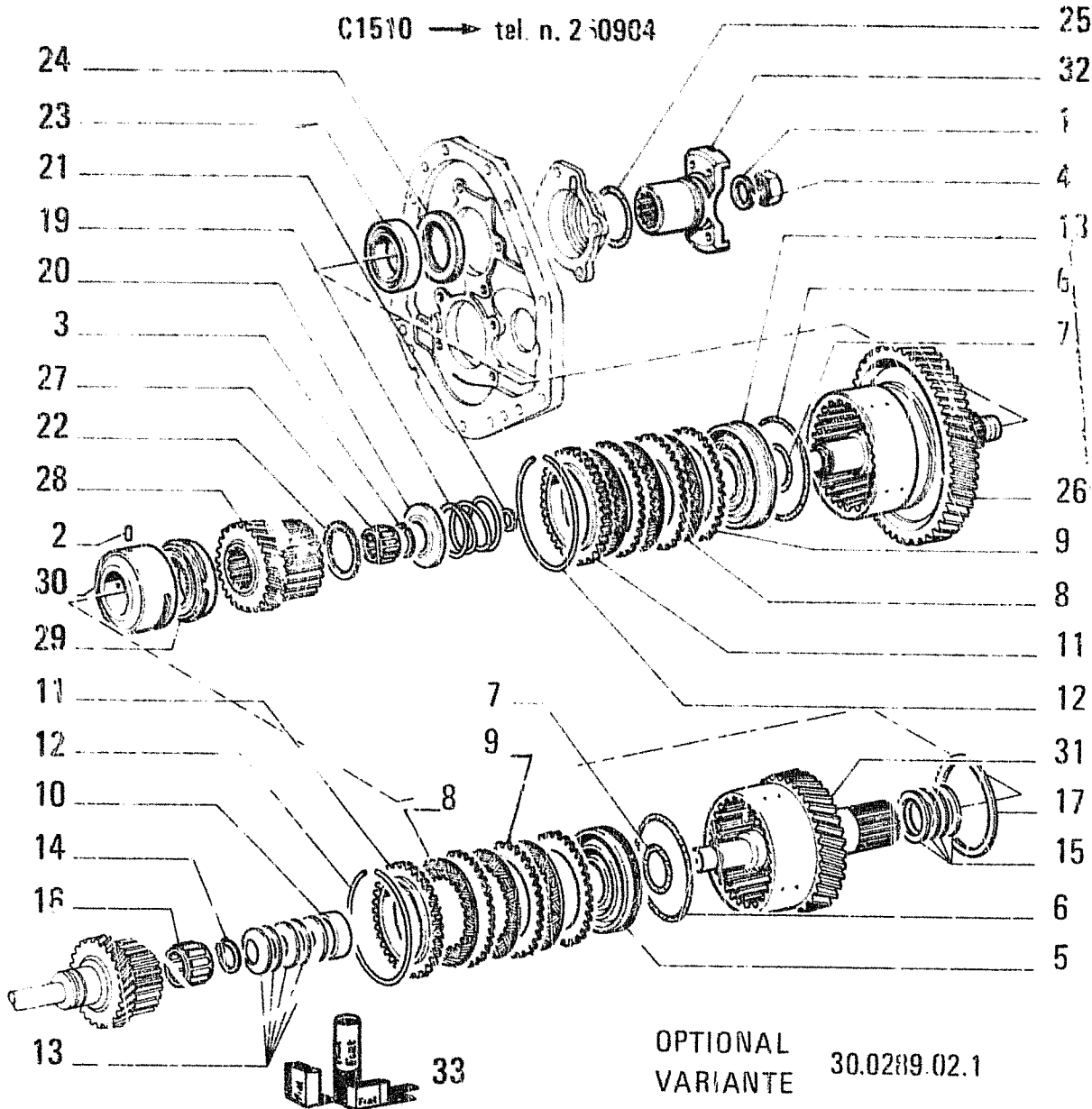

FIATALLIS FD7

B2.01/ 1 TAV. 6 PAG.2

ITEM	PART NUMBER	QTY	TRANS CODE	DESCRIPTION	DESCRIZIONE
28	79030227	1	50I GEAR		INGRANAGGIO
29	79030230	1	341C BEARING		CUSCINETTO
30	79030231	1	135M HUB		MOZZO
31	79030232	1	16A SHAFT		ALBERO
32	79031240	1	70F FLANGE		FLANGIA
33	79055160	1	1K KIT SEE PAGE 9		KIT VED PAG 9

79028189
 TRANSMISSION — CAMBIO DI VELOCITA' — BOITE DE VITESSES — WECHSELGETRIEBE — CAMBIO DE VELOCIDADES

9
 B2.01/1 6
 N.T.R. 191 - 20.02.1990
 604.01.081.04

T5

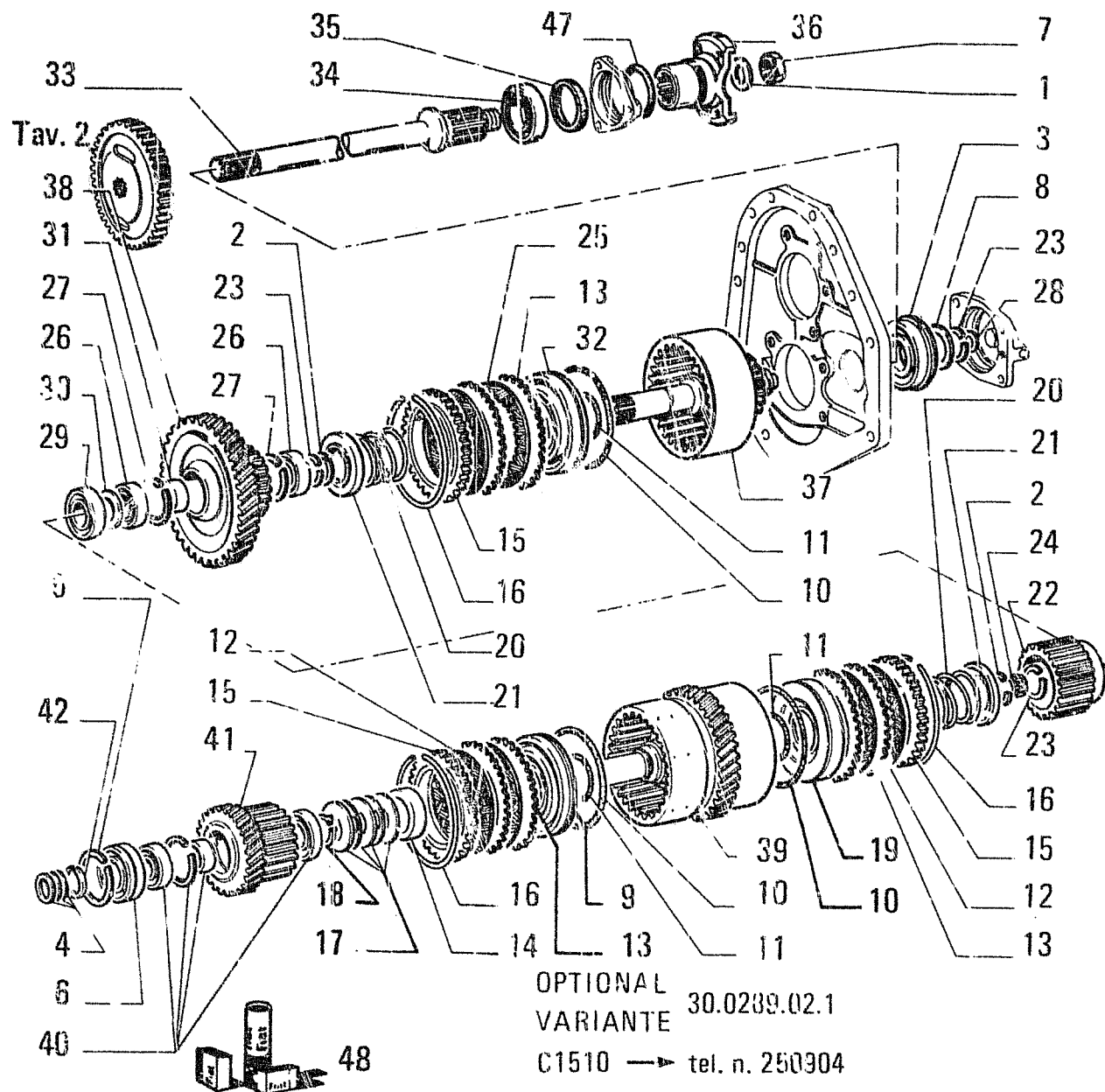

FIATALLIS FB7

B2.01/1 TAV. 7 PAG.1

ITEM	PART NUMBER	QTY	TRANS CODE	DESCRIPTION	DESCRIZIONE
1	70673871	1	131R	WASHER	ROSETTA
2	70926000	2	51A	LOCKRING	ANELLO DI SICUREZZA
3	73132784	1	341C	BEARING	CUSCINETTO
4	71004926	3	45A	RING	ANELLO
5	71004961	1	51A	LOCKRING	ANELLO DI SICUREZZA
6	71004962	1	341C	BEARING	CUSCINETTO
7	73109871	1	10D	NUT	DADO
8	73118058	1	131R	WASHER	ROSETTA
9	73118085	1	130P	PLUNGER	PISTONCINO
10	73118086	3	123G	SEAL ASSY	GUARNIZIONE TENUTA FRONTALE
11	73118087	3	123G	SEAL ASSY	GUARNIZIONE TENUTA FRONTALE
12	73118088	14	60D	DISC	DISCO
13	73118089	22	60D	DISC	DISCO
14	73118090	1	75D	SPACER	DISTANZIALE
15	73118091	3	60D	DISC	DISCO
16	73118092	3	45A	RING	ANELLO
17	73118093	5	100M	SPRING	MOLLA
18	73118094	1	51A	LOCKRING	ANELLO DI SICUREZZA
19	73118106	1	130P	PLUNGER	PISTONCINO
20	73118107	2	100M	SPRING	MOLLA
21	73118108	2	60S	CUP	SCODELLINO
22	73118109	1	135M	HUB	MOZZO
23	73118110	3	51A	LOCKRING	ANELLO DI SICUREZZA
24	73118111	1	341C	BEARING	CUSCINETTO
25	73118133	8	60D	DISC	DISCO
26	73118134	2	341C	BEARING	CUSCINETTO
27	73118135	2	51A	LOCKRING	ANELLO DI SICUREZZA

79028189

9

TRANSMISSION - CAMBIO DI VELOCITA' - BOITE DE VITESSES - WECHSELGETRIEBE - CAMBIO DE VELOCIDADES

B2.01/1

7

N.T.R. 191 - 20.02.1990

604.01.081.04

T6

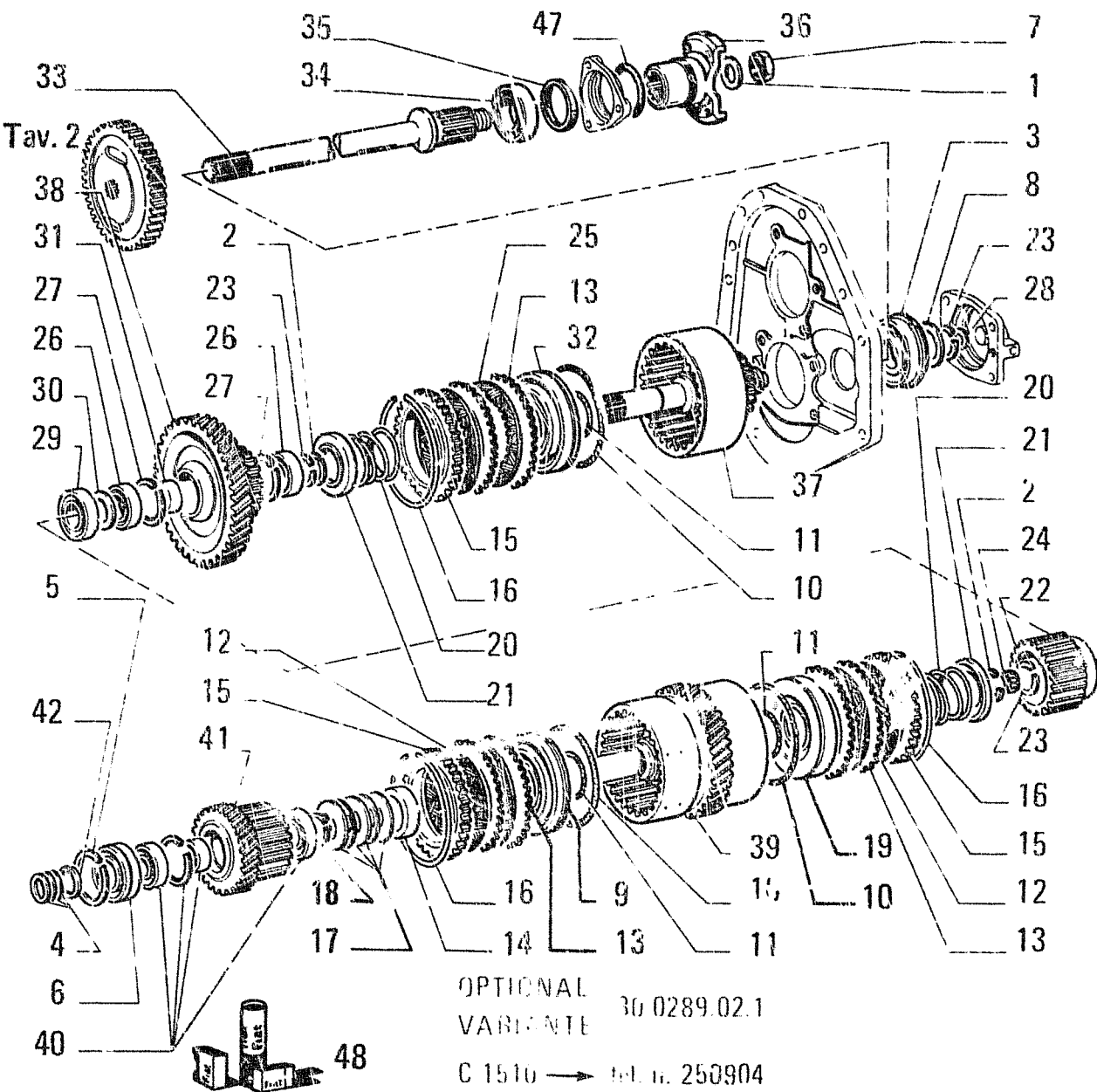

FIATALLIS FD7

ITEM	PART NUMBER	QTY	TRANS CODE	DESCRIPTION	DESCRIZIONE
28	73118136	1	45A	RING	ANELLO
29	73118137	1	341C	BEARING	CUSCINETTO
30	73118138	1	75D	SPACER	DISTANZIALE
31	73118133	1	75D	SPACER	DISTANZIALE
32	73118236	1	130P	PLUNGER	PISTONCINO
33	79030218	1	16A	SHAFT	ALBERO
34	79030219	1	341C	BEARING	CUSCINETTO
35	79030222	1	123G	SEAL ASSY	GUARNIZIONE TENUTA FRONTALE
36	79030223	1	70F	FLANGE	FLANGIA
37	79030228	1	16A	SHAFT	ALBERO
38	79030229	1	50I	GEAR	INGRANAGGIO
39	79030233	1	15A	SHAFT	ALBERO
40	79030234	1	341C	BEARING	CUSCINETTO
41	79030235	1	50I	GEAR	INGRANAGGIO
42	79030236	1	45A	RING	ANELLO
	79030237	1	45A	RING	ANELLO
	79030238	1	45A	RING	ANELLO
	79030239	1	45A	RING	ANELLO
	79030240	1	45A	RING	ANELLO
47	79031008	1	158G	O-RING	GUARNIZIONE O-RING
48	79055160	1	1K	KIT SEE PAGE 9	KIT VED. PAG 9

OPTIONAL VARIANTE 30 0289.02.1
 C 1510 → tel. n. 250904

79028189

9

TRANSMISSION - CAMBIO DI VELOCITA' - BOITE DE VITESSES - WECHSELGETRIEBE - CAMBIO DE VELOCIDADES

B2.01/1

7

N.T.R. 191 - 20.02.1990
 604.01.081.04

OPTIONAL
VARIANTE 30.0289 02.1

D 1510 tel. n. 250905 →

CASINGS AND COVERS
SCATOLE E COPLRCHI

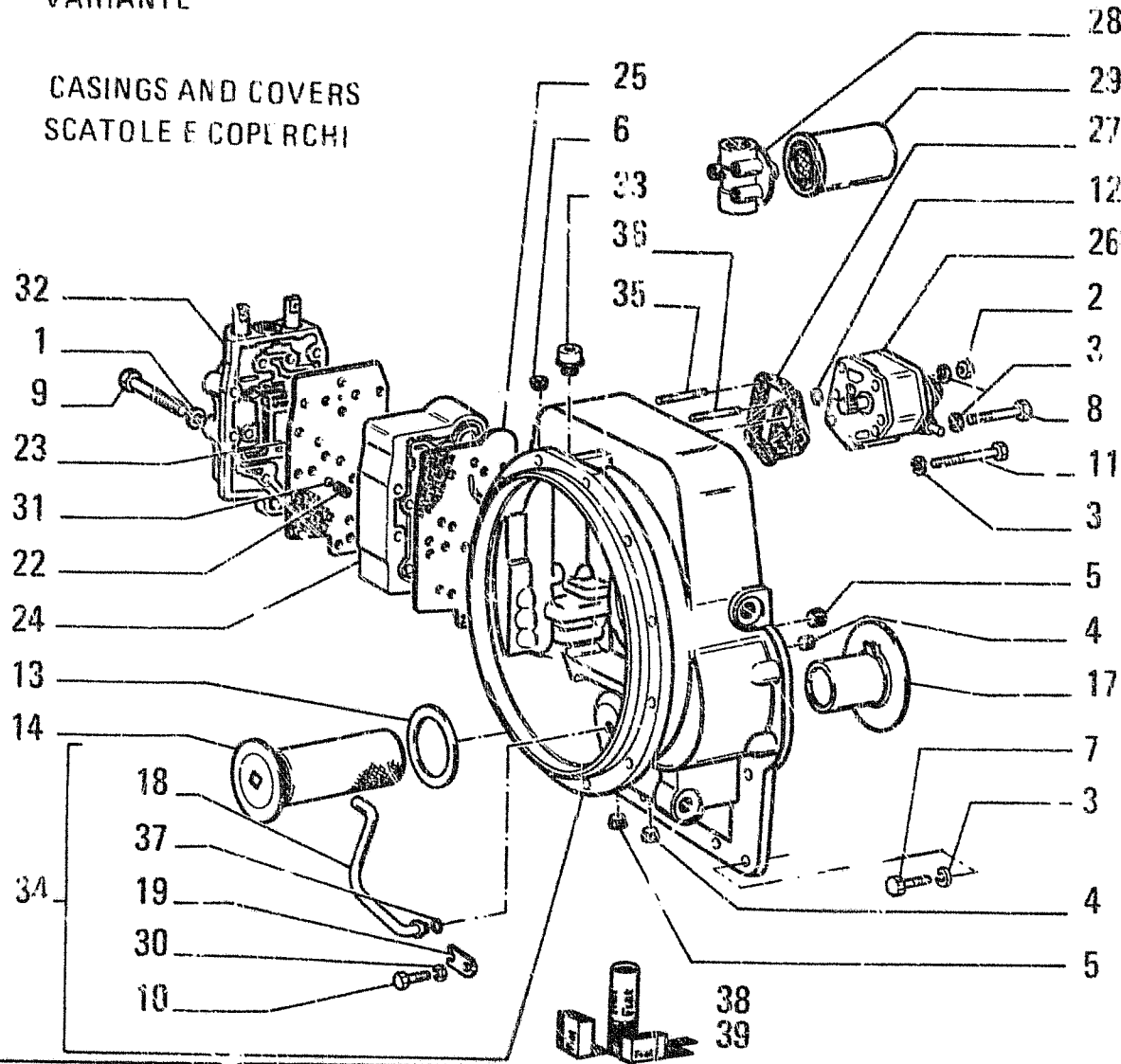

ITEM	PART NUMBER	QTY	TRANS CODE	DESCRIPTION	DESCRIZIONE
1	10516879	9	170R	LOCKWASHER 10,2x2,5	ROSETTA EL 10,2x2,5
2	70910986	2	10D	NUT	DADO
3	70914678	21	131R	WASHER	ROSETTA
4	73131677	2	50T	PLUG	TAPPO
5	70917970	2	50T	PLUG	TAPPO
6	79051077	1	50T	PLUG	TAPPO
7	70921569	16	40V	SCREW	VITE
8	70925821	2	40V	SCREW	VITE
9	70927536	9	40V	SCREW	VITE
10	70927612	1	40V	SCREW	VITE
11	70928527	1	40V	SCREW	VITE
12	14457180	1	158G	O-RING 2,62x13,94	GUARNIZIONE O-R 2,62x13,94
13	71004848	1	123G	SEAL ASSY	GUARNIZIONE TENUTA FRONTALE
14	71004849	1	65F	FILTER	FILTRO
17	73118039	1	135M	HUB	MOZZO
18	73118053	1	193T	TUBE	TUBO RIGIDO
19	73118054	1	45F	CLIP	FERMAGLIO
22	73118121	2	100M	SPRING	MOLLA
23	73118122	1	123G	SEAL ASSY C2911	GUARNIZIONE TENUTA FRONTALE C2911
	79086375	1	122G	SEAL D2911	GUARNIZIONE D2911
24	79060010	1	10V	VALVE - ASSEMBLY SEE SGR. B2.34/A	VALVOLA - COMPLETO VEDERE SGR. B2.34/A
25	73118124	1	123G	SEAL ASSY	GUARNIZIONE TENUTA FRONTALE
26	79051076	1	155P	PUMP	POMPA
27	73118167	1	123G	SEAL ASSY	GUARNIZIONE TENUTA FRONTALE
28	73118170	1	20R	FITTING	RACCORDO

79064264

TRANSMISSION - CAMBIO DI VELOCITA' - BOITE DE VITESSES - WECHSELGETRIEBE - CAMBIO DE VELOCIDADES

9	B2.01/1A	1
N.T.R. 205 - 30.09.1991		
604.01.081.06		

OPTIONAL
VARIANTE 30.0289 02.1

D 1510 tel. n. 250905 →

CASING AND COVERS
SCATOLE E COPERCHI

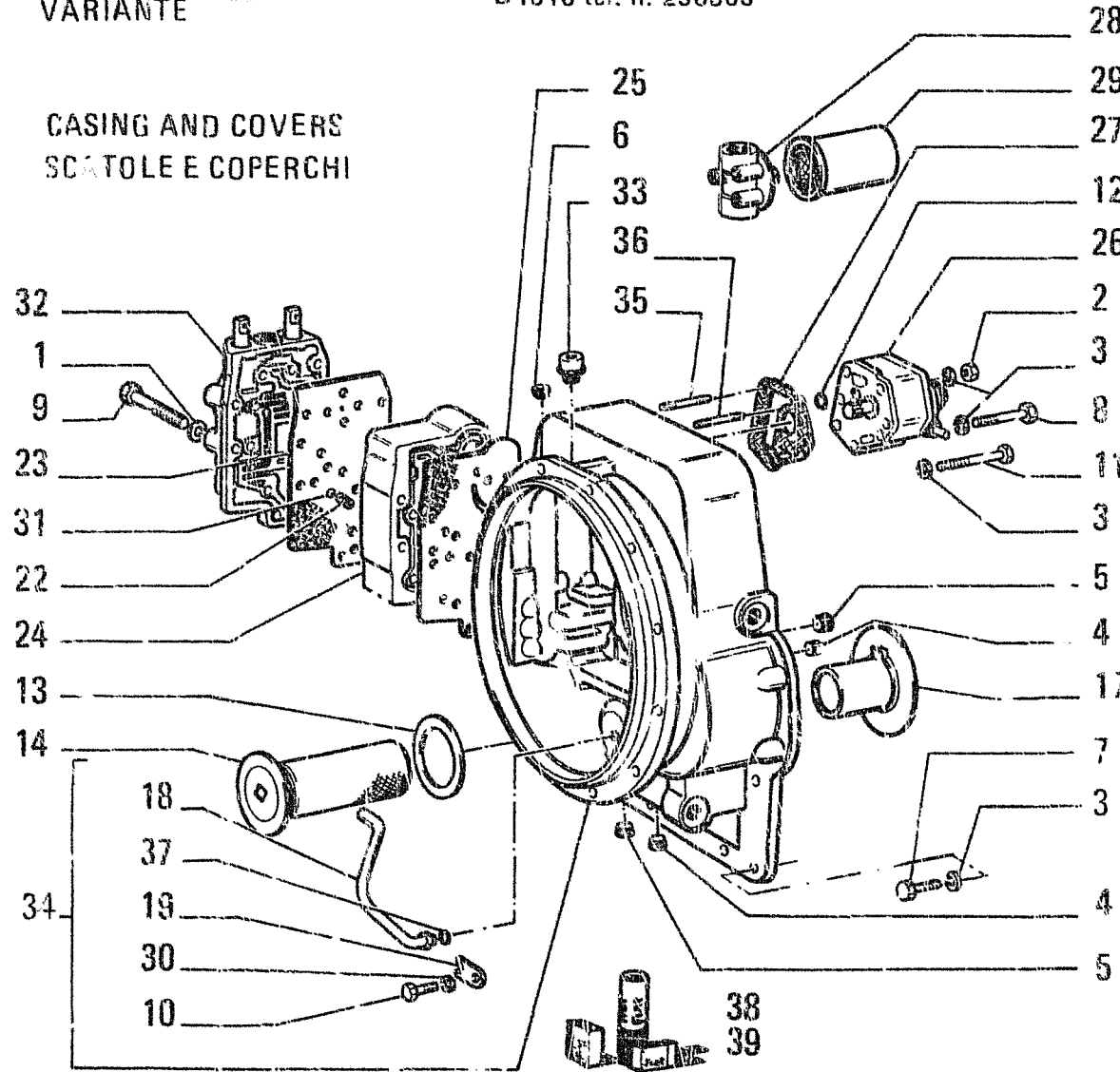

ITEM	PART NUMBER	QTY	TRANS CODE	DESCRIPTION	DESCRIZIONE
29	3118171	1	65F	FILTER G2951	FILTRO C2951
	9104646	1	65F	FILTER D2951	FILTRO D2951
30	10571779	1	131R	WASHER 8,1x2	ROSETTA 8,1x2
31	70905360	2	140S	BALL	SFERA
32	79060012	1	R3D	CONTROL VALVE - ASSEMBLY SEE SGR. B2.33 A	DISTRIBUTORE COMPLETO VEDEPESGR. B2.33/A
33	79030263	1	50T	PLUG	TAPPO
34	79056361	1	35S	CASE - ASSEMBLY	SCATOLA - COMPLETO
35	79030999	1	210P	STUD	PRIGIONIERO
36	79031000	1	210P	STUD	PRIGIONIERO
37	79031003	1	153G	O-RING	GUARNIZIONE O-R
38	79055159	1	1K	KIT SEE PAGE 9	KIT VED. PAG.9
39	79055160	1	1K	KIT SEE PAGE 9	KIT VED. PAG.9

79064264

9

TRANSMISSION - CAMBIO DI VELOCITA' - BOITE DE VITESSES - WECHSELGETRIEBE -
CAMBIO DE VELOCIDADES

B2.01/ A 1

N.T.R. 205 - 30.09.1991
604.00181.06

T9

OPTIONAL
VARIANTE 30.0289.02.1

☎ 1519 tel. n. 250905 →

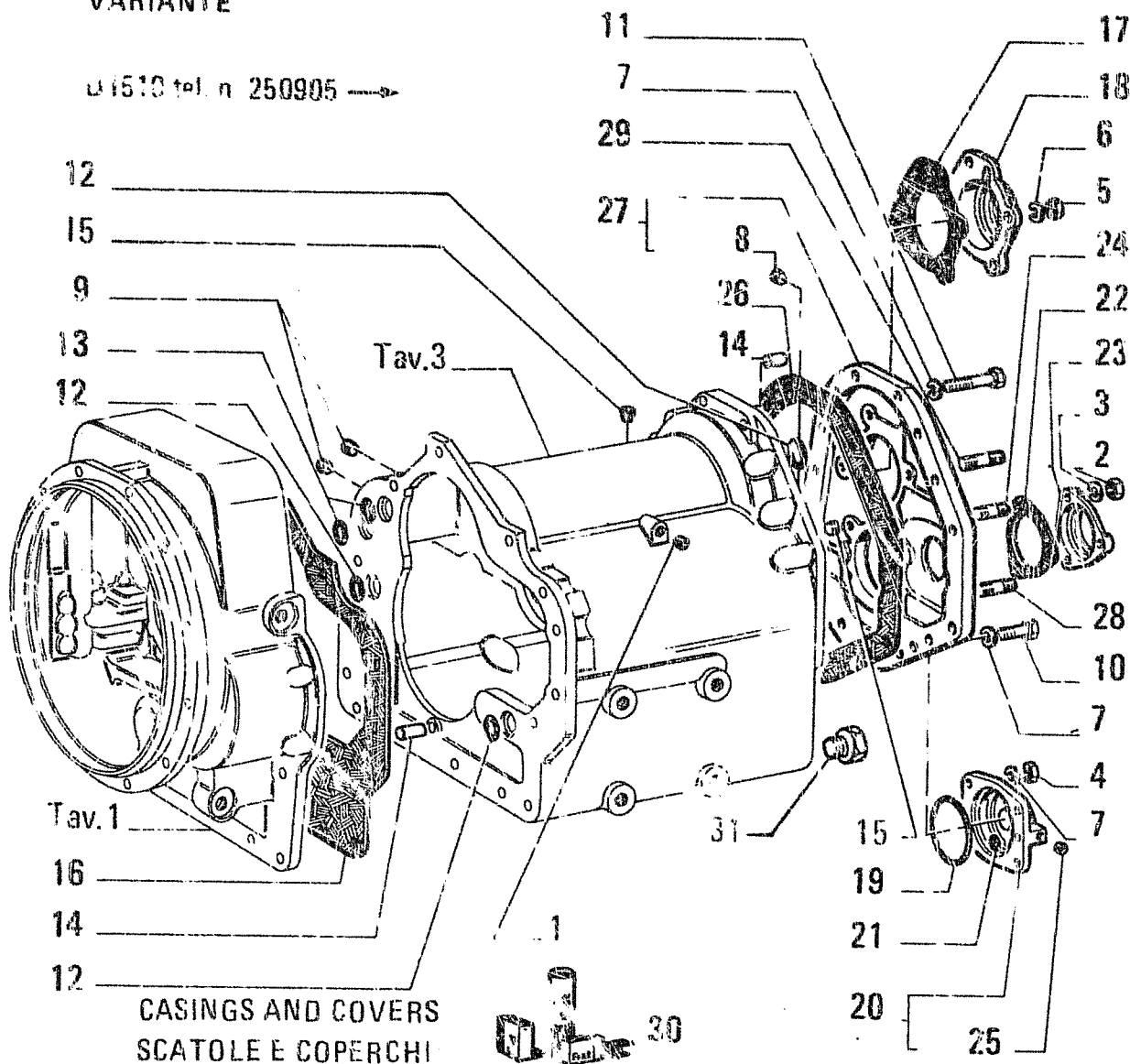

FIATALLIS FD7

92.01/ 1A TAV. 2 PAG.1

ITEM	PART NUMBER	QTY	TRANS CODE	DESCRIPTION	DESCRIZIONE
1	70673860	1	50T P.UG		TAPPO
2	70910123	3	10D NJT		DAJO
3	10516879	3	170R LOCKWASHER 10,2x2,5		ROSETTA EL. 10,2x2,5
4	70910986	4	10D NJT		DAJO
5	70911331	4	10D NJT		DAJO
6	70912433	4	131R WASHER		ROSETTA
7	70914678	19	131R WASHER		ROSETTA
8	70917673	1	50T P.UG		TAPPO
9	79051077	2	50T P.UG		TAPPO
10	70921589	6	40V SCREW		VITE
11	70927583	9	40V SCREW		VITE
12	14462980	3	158G C-RING 3,53x20,22		GIARNIZIONE O-R 3,53x20,22
13	14457180	2	158G C-RING 2,62x13,94		GIARNIZIONE O-R 2,62x13,94
14	71004838	3	83P PIN		PIGILINO
15	73066768	2	50T P.UG		TAPPO
16	73118040	1	123G SEAL ASSY		GIARNIZIONE TENUTA FRONTALE
17	79030211	1	123G SEAL ASSY		GIARNIZIONE TENUTA FRONTALE
18	79030212	1	265C COVER		COPERCHIO
19	79030215	1	158G C-RING		GIARNIZIONE O-R
20	79030216	1	265C COVER - ASSEMBLY C2950		COPERCHIO - COMPLETO C2950
	79102690	1	265C COVER - ASSEMBLY D2950		COPERCHIO - COMPLETO D2950
21	79030217	1	158G C-RING		GIARNIZIONE O-R
22	79030220	1	123G SEAL ASSY		GIARNIZIONE TENUTA FRONTALE
23	79030221	1	265C COVER		COPERCHIO
24	79060004	3	210P STUD		PIGIONIERO

79064264

TRANSMISSION - CAMBIO DI VELOCITA' - BOITE DE VITESSES - WECHSELGETRIEBE - CAMBIO DE VELOCIDADES

92.01/1A 2

N. F. R. 205 - 30.09.1991
604.01.081.06

T10

OPTIONAL
VARIANTE 30.0289.02.1

D1510 tel. n. 250905 →

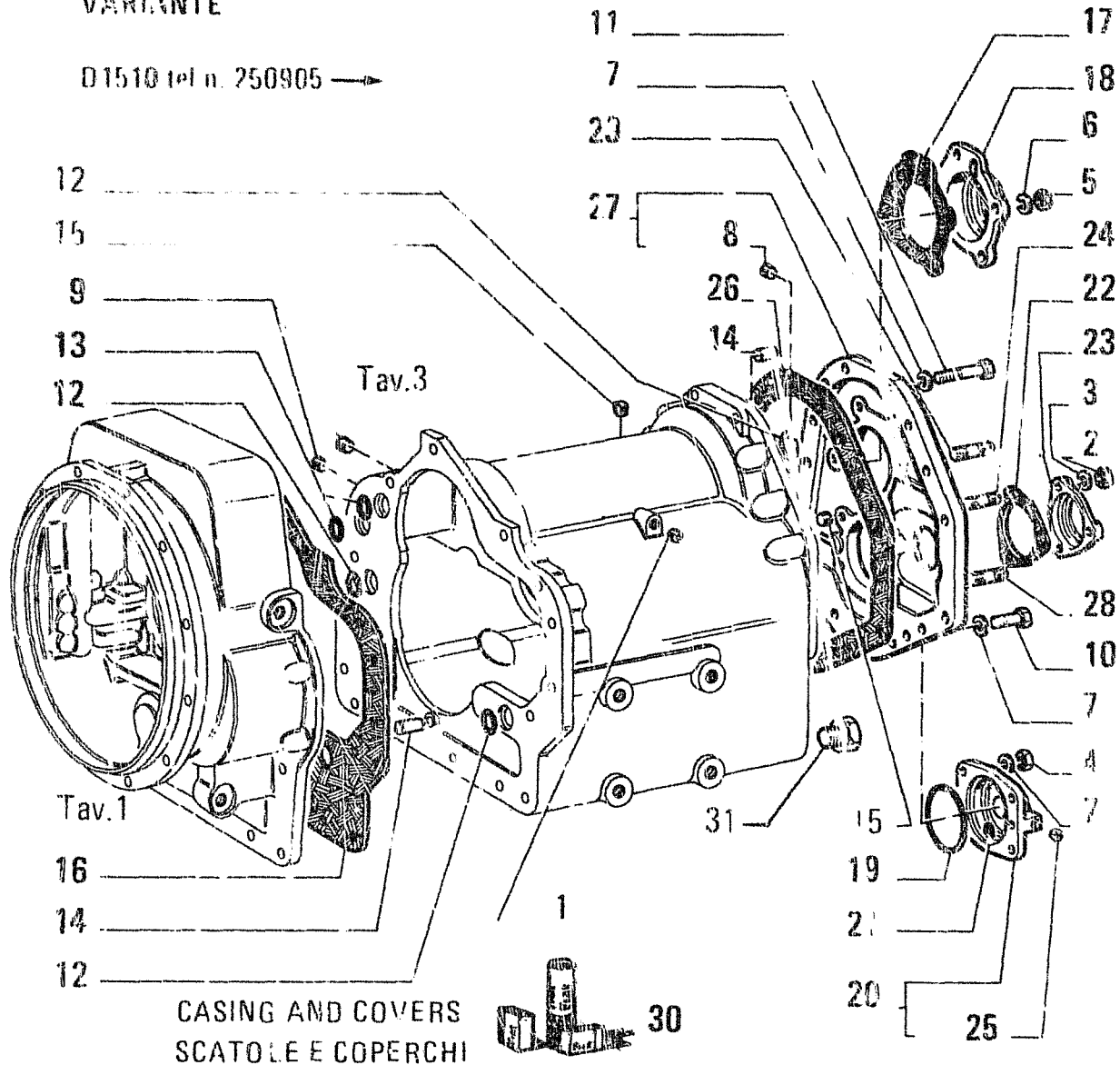

CASING AND COVERS
SCATOLE E COPERCHI

FIATALLIS FD7

B2.01/ 1A TAV. 2 PAG.2

ITEM	PART NUMBER	QTY	TRANS CODE	DESCRIPTION	D. SCRIZIONE
25	79030241	1	50T PLUG	TAPPO	
26	79030266	1	1233 SEAL ASSY	GUARNIZIONE TEUTA FRONTALE	
27	79030267	1	265C COVER - ASSEMBLY	COPERCHIO - COMPLETO	
28	79031001	4	210P STUD	PRIGIONIERO	
29	79031002	4	210P STUD	PRIGIONIERO	
30	79055160	1	1K KIT SEE PAGE 9	KIT VED PAG 9	
31	79060009	1	50T PLUG	TAPPO	

79064264

TRANSMISSION - CAMBIO DI VELOCITA' - BOITE DE VITESSES - WECHSELGETRIEBE - CAMBIO DE VELOCIDADES

B2.01/1A

2

N.T.R. 205 - 30.09.1991
604.01.081.06

T11

OPTIONAL
VARIANTE

30.0289.02.1

D 1510 tel. n. 250905 →

CASINGS AND COVERS
SCATOLE E COPERCHI

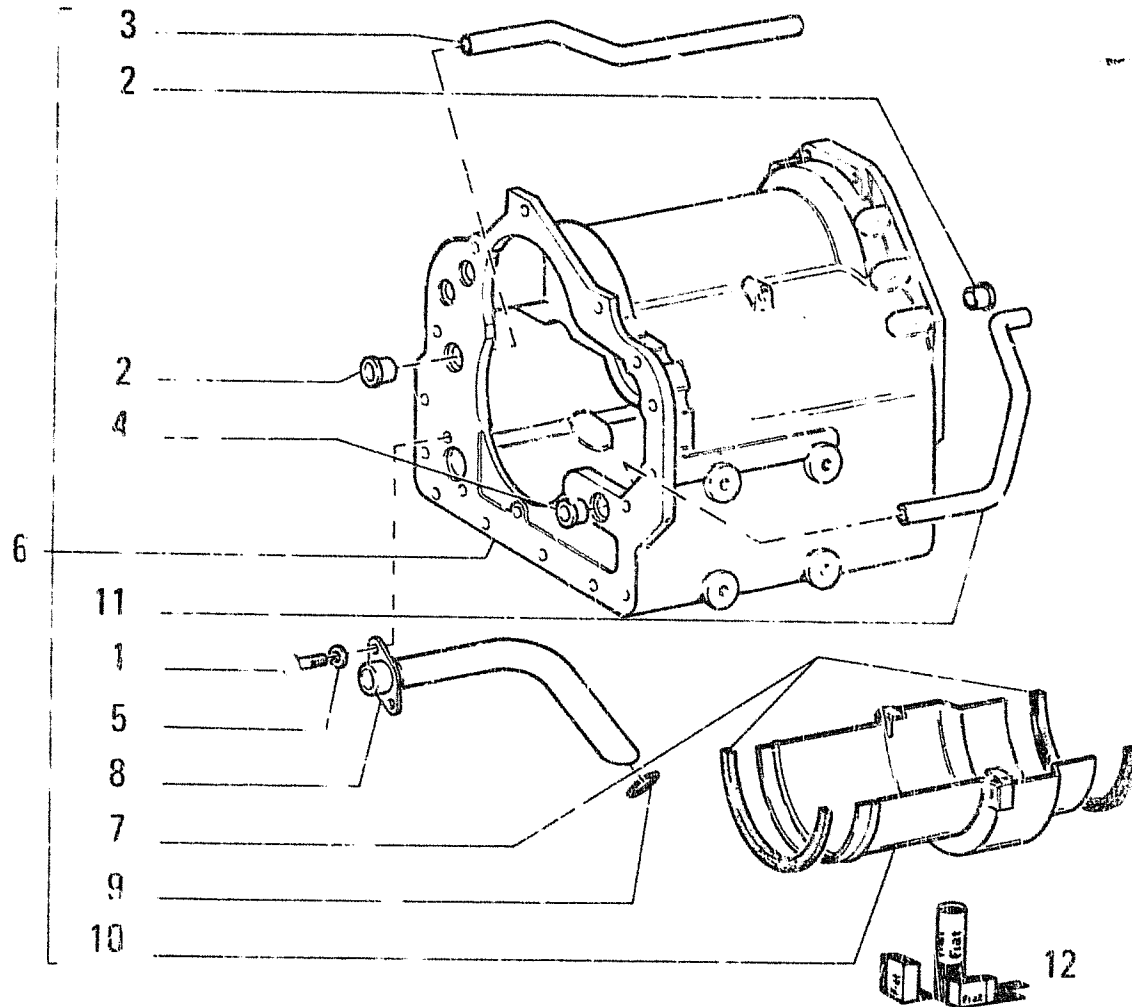

ITEM	PART NUMBER	QTY	TRANS CODE	DESCRIPTION	DESCRIZIONE
1	70027612	2	40V	SCREW	VITE
2	71004820	2	135M	HUB	MOZZO
3	73118043	1	193T	TUBE	TUBO RIGIDO
4	73118044	1	135M	HUB	MOZZO
5	10571779	2	131R	WASHER 8,1x2	ROSETTA 8,1x2
6	79056362	1	36S	CASE - ASSEMBLY	SCATOLA - COMPLETO
7	79030268	2	123G	SEAL ASSY	GUARNIZIONE TENUTA FRONTALE
8	79030269	1	193T	TUBE	TUBO RIGIDO
9	79030270	1	158G	O-RING	GUARNIZIONE O-R
10	79030271	1	20D	D FLECTOR	DEFLETTOR
11	79030277	1	193T	TUBE	TUBO RIGIDO
12	79055160	1	1K	KIT SEE PAGE 9	KIT VED. PAG.9

79064264

TRANSMISSION - CAMBIO DI VELOCITA' - BOITE DE VITESSES - WECHSELGETRIEBE - CAMBIO DE VELOCIDADES

9

B2.01/1A 3

N.T.R. 203 - 30.09.1991
604.01.081.06

T12

OPTIONAL
VARIANTE 30.0289.02.1

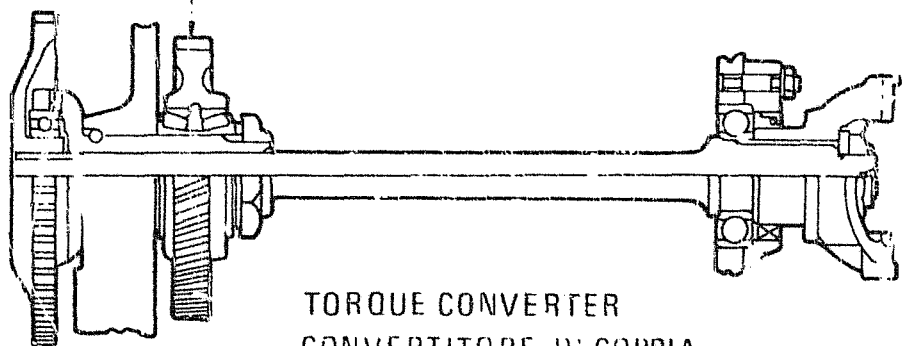
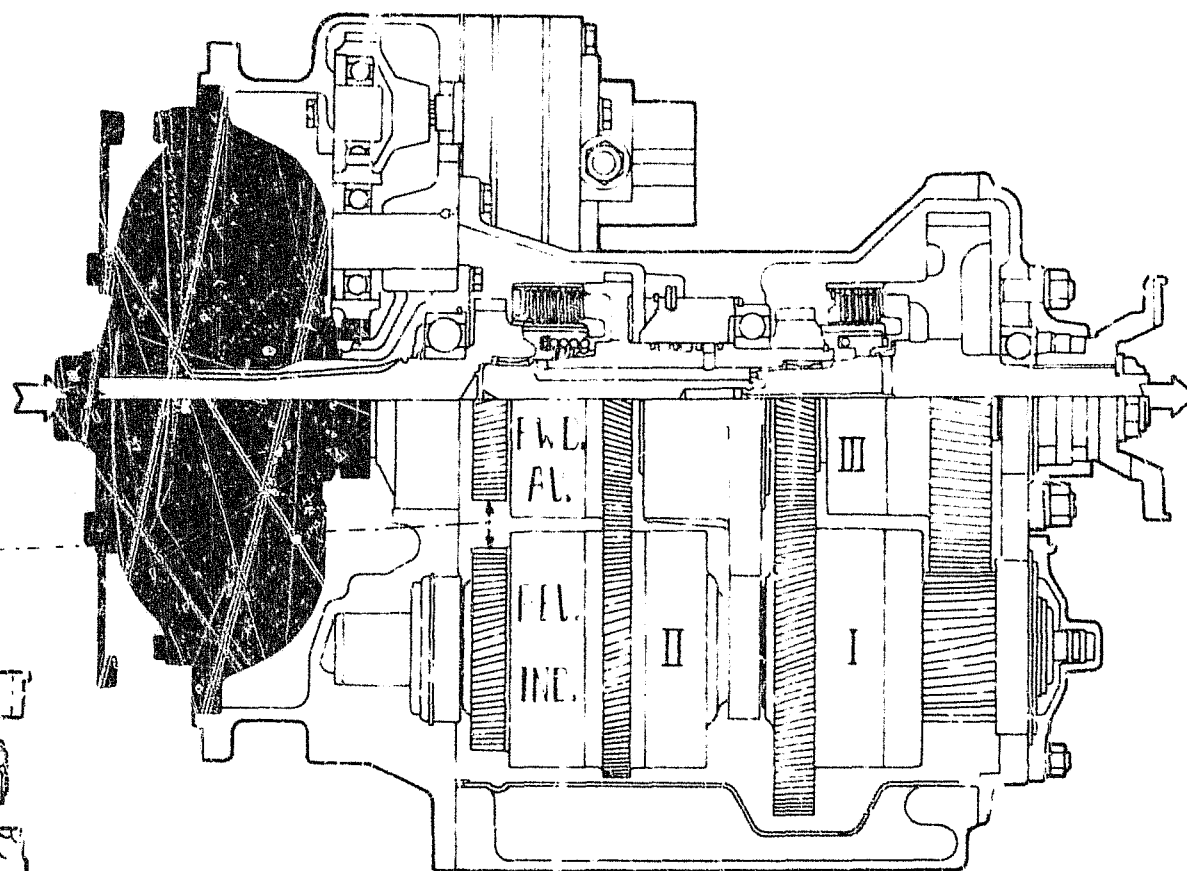

TORQUE CONVERTER
CONVERTITORE DI COPPIA

79064264

TRANSMISSION -- CAMBIO DI VELOCITA' - BOITE DE VITESSES - WECHSELGETRIEBE - CAMBIO DE VELOCIDADES

T13

B2.01/1A

4

N.T.R. 205 - 30.09.1997
604.01.081.06

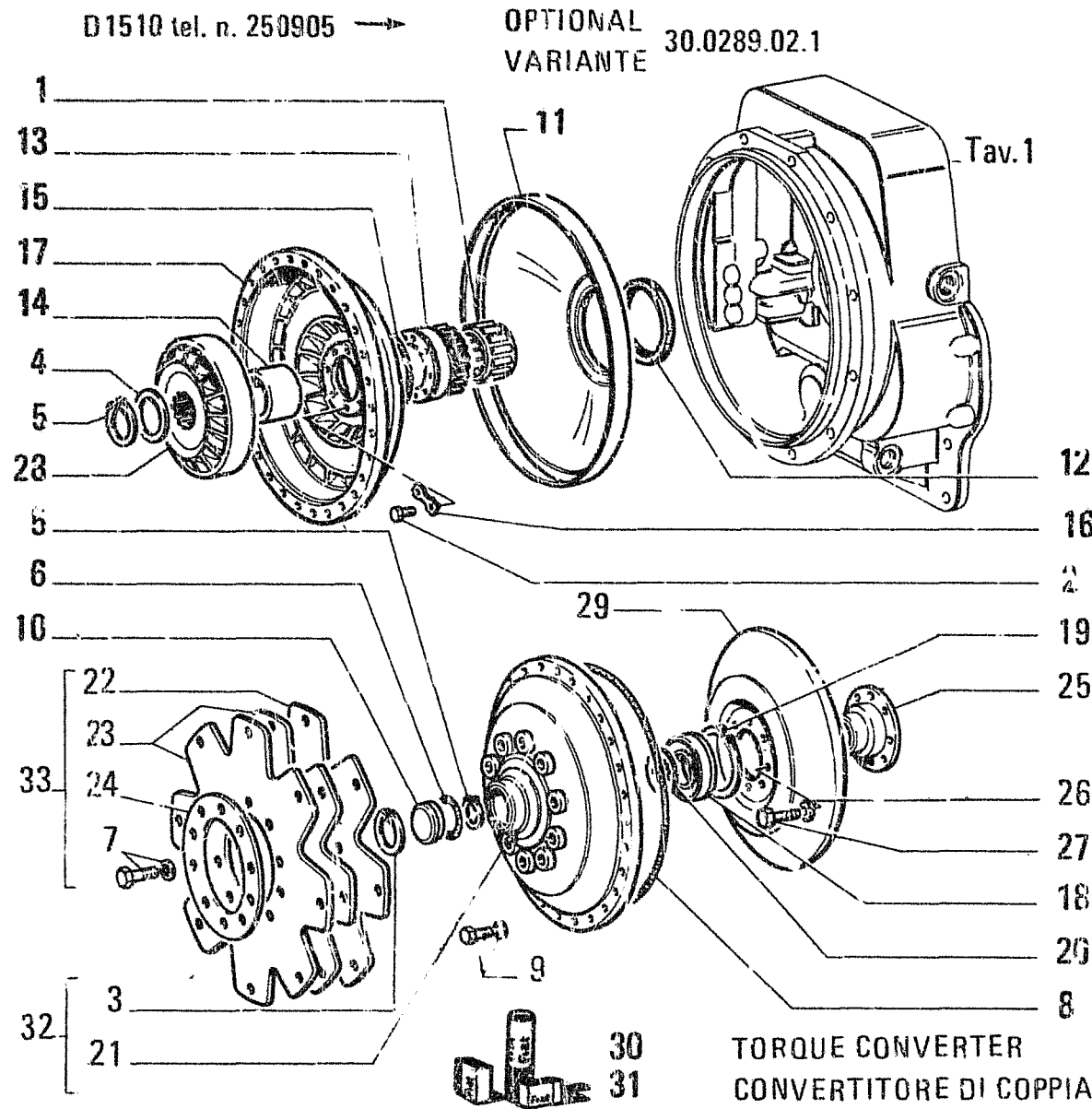

ITEM	PART NUMBER	QTY	TRANS CODE	DESCRIPTION	DESCRIZIONE
1	70673970	1	341C	BEARING	CUSCINETTO
2	79051207	8	40V	SCREW	VITE
3	79111658	1	51A	LOCKRING C2950	ANELLO DI SICUREZZA C2950
4	70927747	1	45A	RING	ANELLO
5	70928720	2	51A	LOCKRING	ANELLO DI SICUREZZA
6	14458580	1	158G	O-RING 2,62x36,17	GUARNIZIONE O-R 2,62x36,17
7	71004835	10	44V	SCREW AND WASHER ASSY C2950	VITE CON ROSETTA C2950
8	71005536	1	158G	O RING	GUARNIZIONE O-R
9	71008468	24	44V	SCREW AND WASHER ASSY	VITE CON ROSETTA
10	73117963	1	50T	PLUG	TAPPO
11	73118063	1	20D	DEFLECTOR	DEFLETTORE
12	73118064	1	122G	SEAL	GUARNIZIONE
13	73118065	1	50I	GEAR	INGRANAGGIO
14	73118066	1	75D	SPACER	DISTANZIALE
15	73118067	1	158G	O-RING	GUARNIZIONE O-R
16	73118068	8	110P	PLAQUE	PIASTRINA
17	73118069	1	60G	IMPELLER	GIRANTE
18	73118072	1	341C	BEARING	CUSCINETTO
19	73118073	1	51A	LOCKRING	ANELLO DI SICUREZZA
20	73118074	1	131R	WASHER	ROSETTA
21	73132674	1	265C	COVER C2950	COPRICHIO C2950
22	73118173	1	75M	DIAPHRAGM C2950	MEMBRANA C2950
23	73118174	2	75M	DIAPHRAGM C2950	MEMBRANA C2950
24	73118175	1	45A	RING C2950	ANELLO C2950
25	79051688	1	135M	HUB	MOZZO

79064264

TRANSMISSION - CAMBIO DI VELOCITA' - BOITE DE VITESSES - WECHSELGETRIEBE - CAMBIO DE VELOCIDADES

B2.01/1A 5

N.Y.R. 205 - 30.03.1991
604.01.081.06

10A

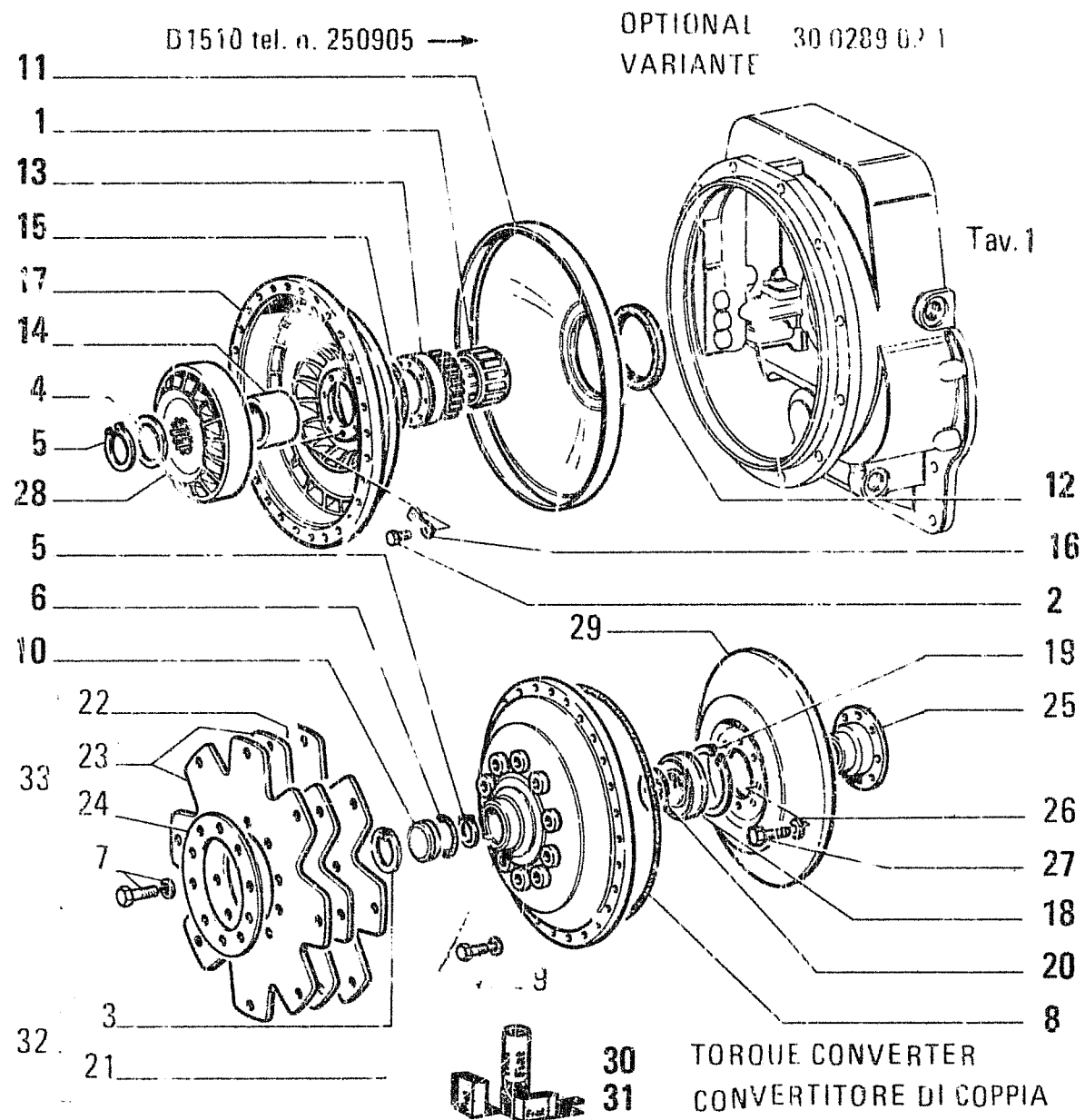

FIAT/LIS FD7

B2.01/1A TAV. 5 PAG.2

ITEM	PART NUMBER	QTY	TRANS CODE	DESCRIPTION	DESCRIZIONE
26	71004797	12	131S	WASHER	ROSETTA
27	71004795	12	407	SCREW	VITE
28	79060011	1	271S	STATOR	STATORE
29	79056360	1	60G	IMPELLER	GIRANTE
30	79055159	1	1K	KIT SEE PAGE 9	KIT VED. PAG.9
31	79055160	1	1K	KIT SEE PAGE 9	KIT VED. PAG.9
32	79086374	1	265C	COVER D2950	COPERCHIO D2950
33	79102227	1	75M	DIAPHRAGM D2950	MEMBRANA D2950

79064264

TRANSMISSION - CAMBIO DI VELOCITA' - BOITE DE VITESSES - WECHSELGETRIEBE - CAMBIO DE VELOCIDADES

B2.01/1A 5

N.T.R. 205 - 30.09.1991
604.01.081.06

T15

OPTIONAL
VARIANTE 30.0289.02.

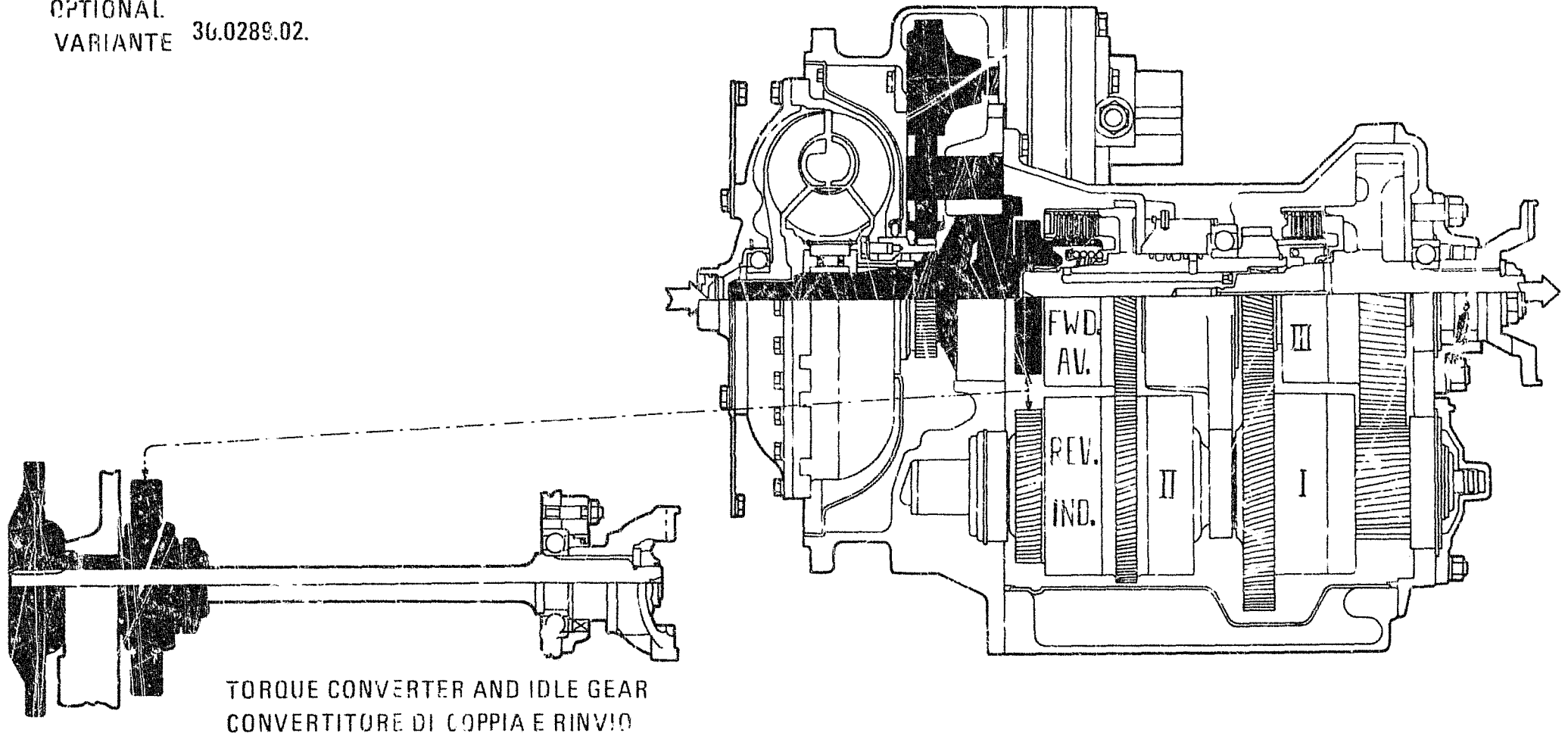

TORQUE CONVERTER AND IDLE GEAR
CONVERTITORE DI COPPIA E RINVIO

79064264

TRANSMISSION – CAMBIO DI VELOCITA' – BOITE DE VITESSES – WECHSELGETRIEBE – CAMBIO DE VELOCIDADES

B2.01/1A

6

N.T.R. 205 - 30.09.1991
604.01.081.06

T16

TORQUE CONVERTER AND IDLE GEAR
 CONVERTITORE DI COPPIA E RINVIO

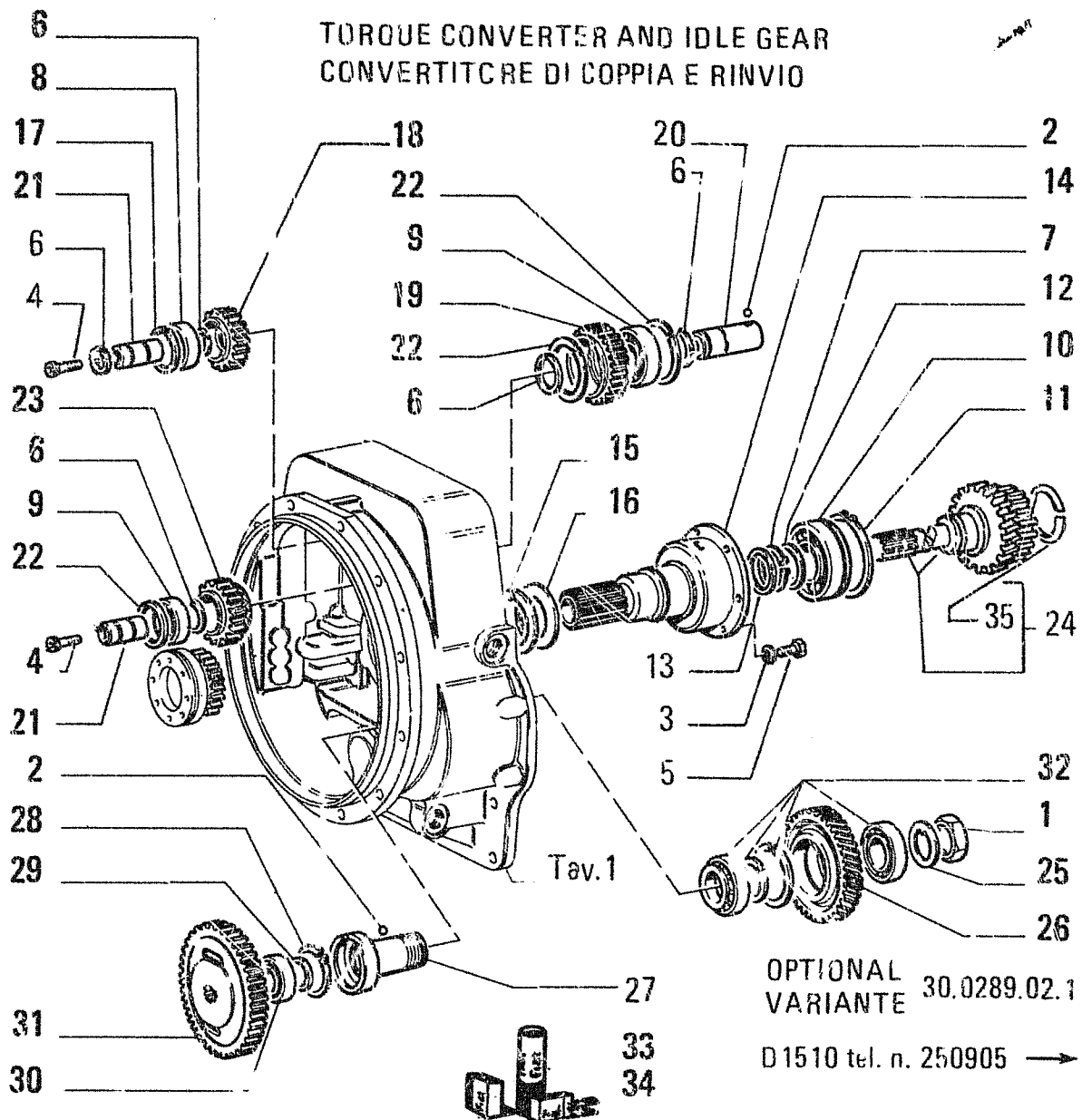

FIATALLIS FD7

ITEM	PART NUMBER	QTY	TRANS CODE	DESCRIPTION	DESCRIZIONE
1	70059946	1	10D NUT	DADO	
2	70673856	2	140S BALL	SFERA	
3	10516879	6	170R LOCKWASHER 10,2x2,5	ROSETTA EL. 10,2x2,5	
4	70921076	4	40V SCREW	VITE	
5	70922763	6	40V SCREW	VITE	
6	70929166	6	45A RING	ANELLO	
7	73116957	1	51A LOCKRING	ANELLO DI SICUREZZA	
8	73116959	1	311C BEARING	CUSCINETTO	
9	73116971	2	341C BEARING C2950	CUSCINETTO C2950	
	79064455	2	341C BEARING D2950	CUSCINETTO D2950	
10	73132932	1	341C BEARING	CUSCINETTO	
11	73118057	1	51A LOCKRING	ANELLO DI SICUREZZA	
12	73118058	2	131R WASHER	ROSETTA	
13	73118059	1	45A RING	ANELLO	
14	79059927	1	300S SUPPORT	SUPPORTO	
15	73118061	1	45A RING C2911	ANELLO C2911	
	79064451	1	45A RING D2911	ANELLO D2911	
16	73118062	1	100M SPRING	MOLLA	
17	73118080	1	45A RING	ANELLO	
18	73118081	1	50I GEAR	INGRANAGGIO	
19	73118082	1	50I GEAR	INGRANAGGIO	
20	73118083	1	16A SHAFT	ALBERO	
21	73118262	2	300S SUPPORT	SUPPORTO	
22	73118320	3	45A RING	ANELLO	
23	79030242	1	50I GEAR	INGRANAGGIO	
24	79052635	1	16A SHAFT - ASSEMBLY	ALBERO - COMPLETO	
25	79030247	2	131R WASHER	ROSETTA	

79064264

9

TRANSMISSION - CAMBIO DI VELOCITA' - BOITE DE VITESSES - WECHSELGETRIEBE - CAMBIO DE VELOCIDADES

B2.01 / 1A

7

N.T.R. 205 - 30.09.1991
 604.01.081.06

T17

B

MECHANICAL TRANSMISSION • CLUTCH • TRANSMISSION • TRANSMISSION SHAFT • AXLES
TRASMISSIONE MECCANICA • FRIZIONE • CAMBIO • ALBERO DI TRASMISSIONE • PONTI
TRANSMISSION MECANIQUE • EMBRAYAGE • BOITE DE VITESSES • ARBRE DE TRANSMISSION • PONTS
MECHANISCHE KRAFTÜBERTRAGUNG • KUPPLUNG • GETRIEBE • GELENKWEILE • AXSEN
TRANSMISSION MECANICA • EMBRAGUE • CAMBIO • ARBOL DE TRANSMISSION • PUENTES

TORQUE CONVERTER AND IDLE GEAR
CONVERTITORE DI COPPIA E RINVIO

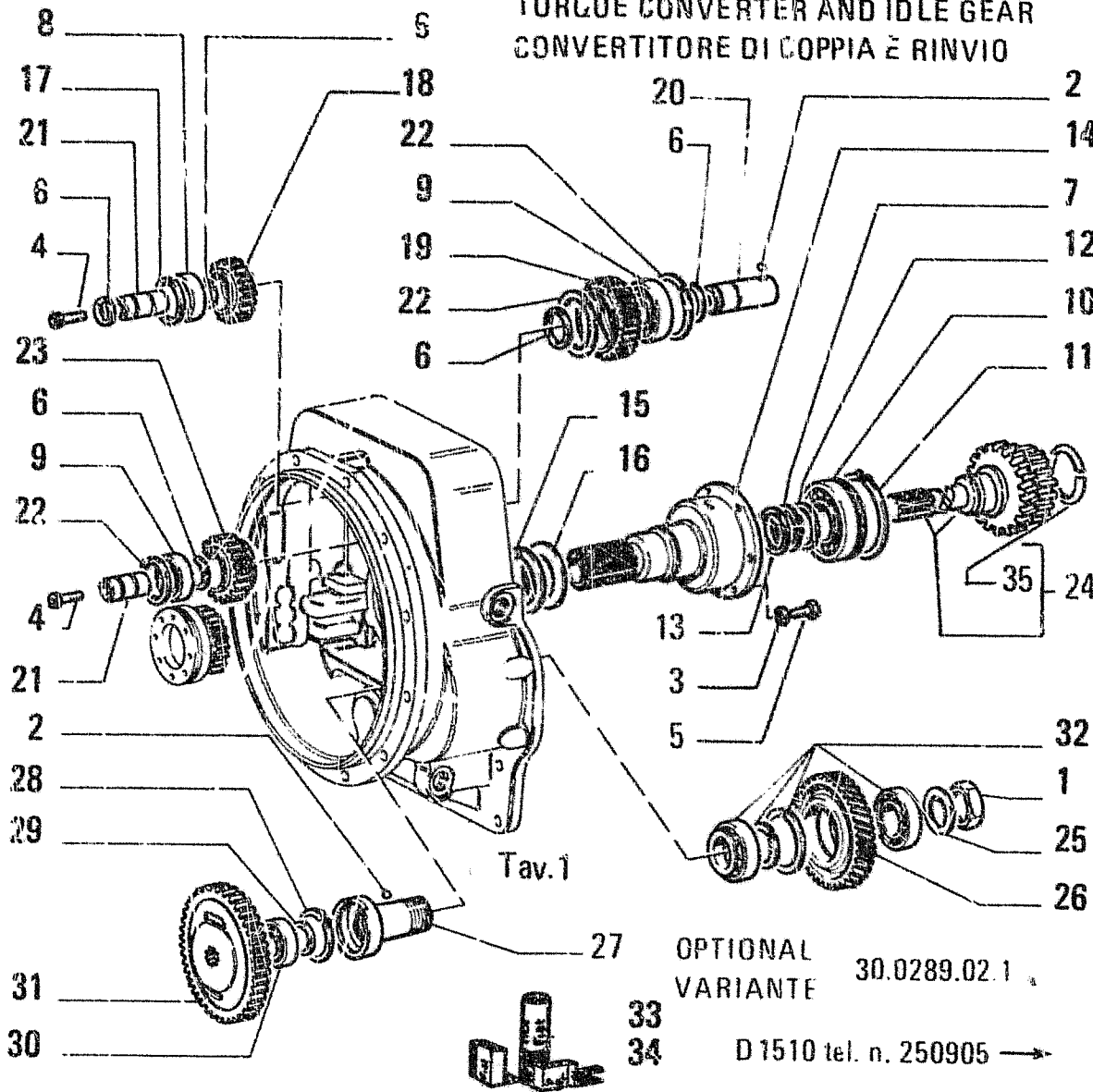

ITEM	PART NUMBER	QTY	TRANS CODE	DESCRIPTION	DESCRIZIONE
26	79030248	1	50I GEAR		INGRANAGGIO
27	79030249	1	16A SHAFT		ALBERO
28	79030250	1	51A LOCKRING		ANELLO DI SICUREZZA
29	79030251	1	45A RING		ANILLO
30	79030252	1	341C BEARING		CUSCINETTO
31	79030253	1	50I GEAR		INGRANAGGIO
32	79030261	1	341C BEARING		CUSCINETTO
33	79055159	1	1K KIT SEE PAGE 9		KIT VED. PAG.9
34	79055160	1	1K KIT SEE PAGE 9		KIT VED. PAG.9
35	79064449	1	51A LOCKRING		ANELLO DI SICUREZZA

OPTIONAL VARIANTE 30.0289.02.1

D 1510 tel. n. 250905 →

79064264

TRANSMISSION - CAMBIO DI VELOCITA' - BOITE DE VITESSES - WECHSELGETRIEBE - CAMB'IO DE VELOCIDADES

9

B2.01 / 1A 7

N.T.R. 205 - 30.09.1991
604.01.081.06

OPTIONAL
VARIANTE

30.0289.02.1

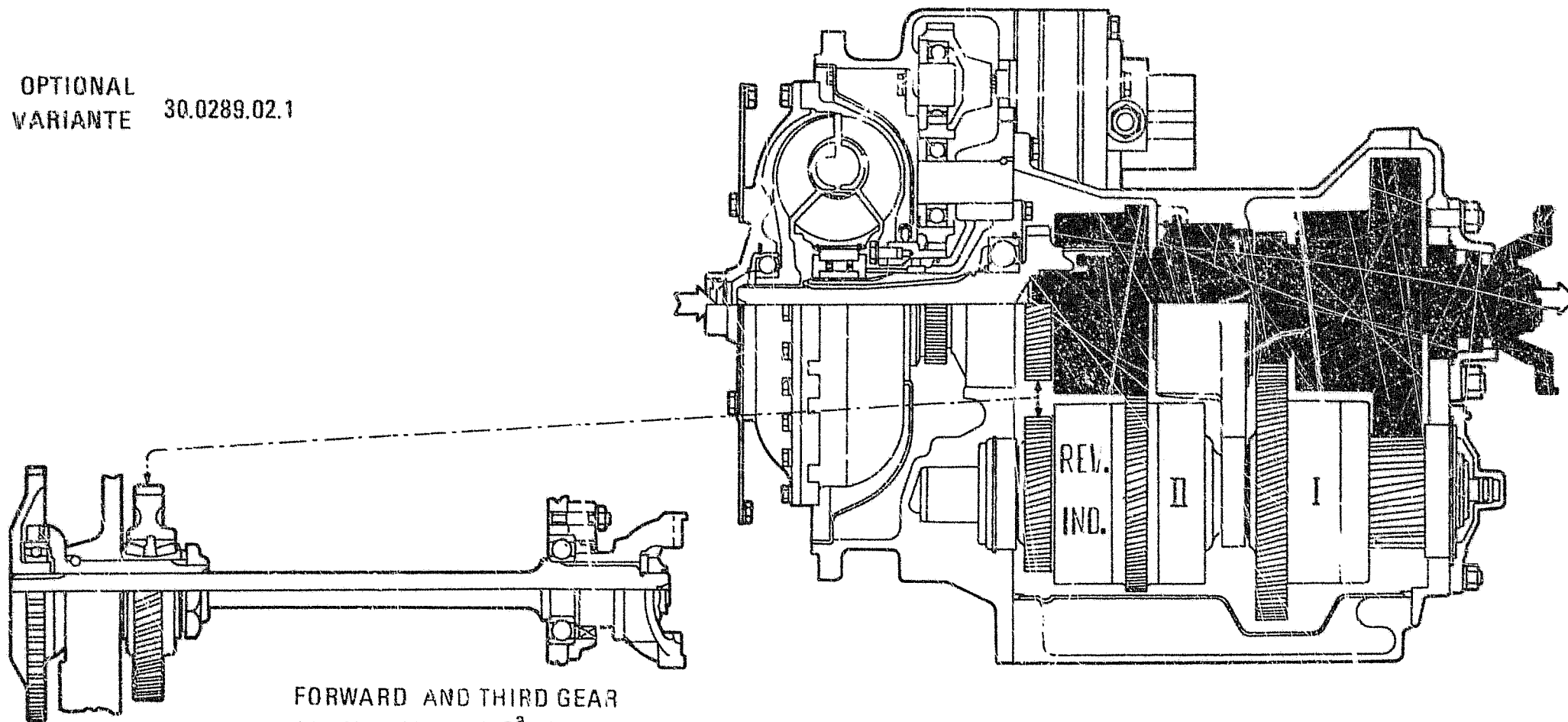

FORWARD AND THIRD GEAR
MARCIA AVANTI E 3^a MARCIA

79064264

B2.01/1A

8

TRANSMISSION - CAMBIO DI VELOCITA' -- BOITE DE VITESSES - WECHSELGETRIEBE - CAMBIO DE VELOCIDADES

N.T.R. 205 - 30.09.1991
604.01.081.06

H3

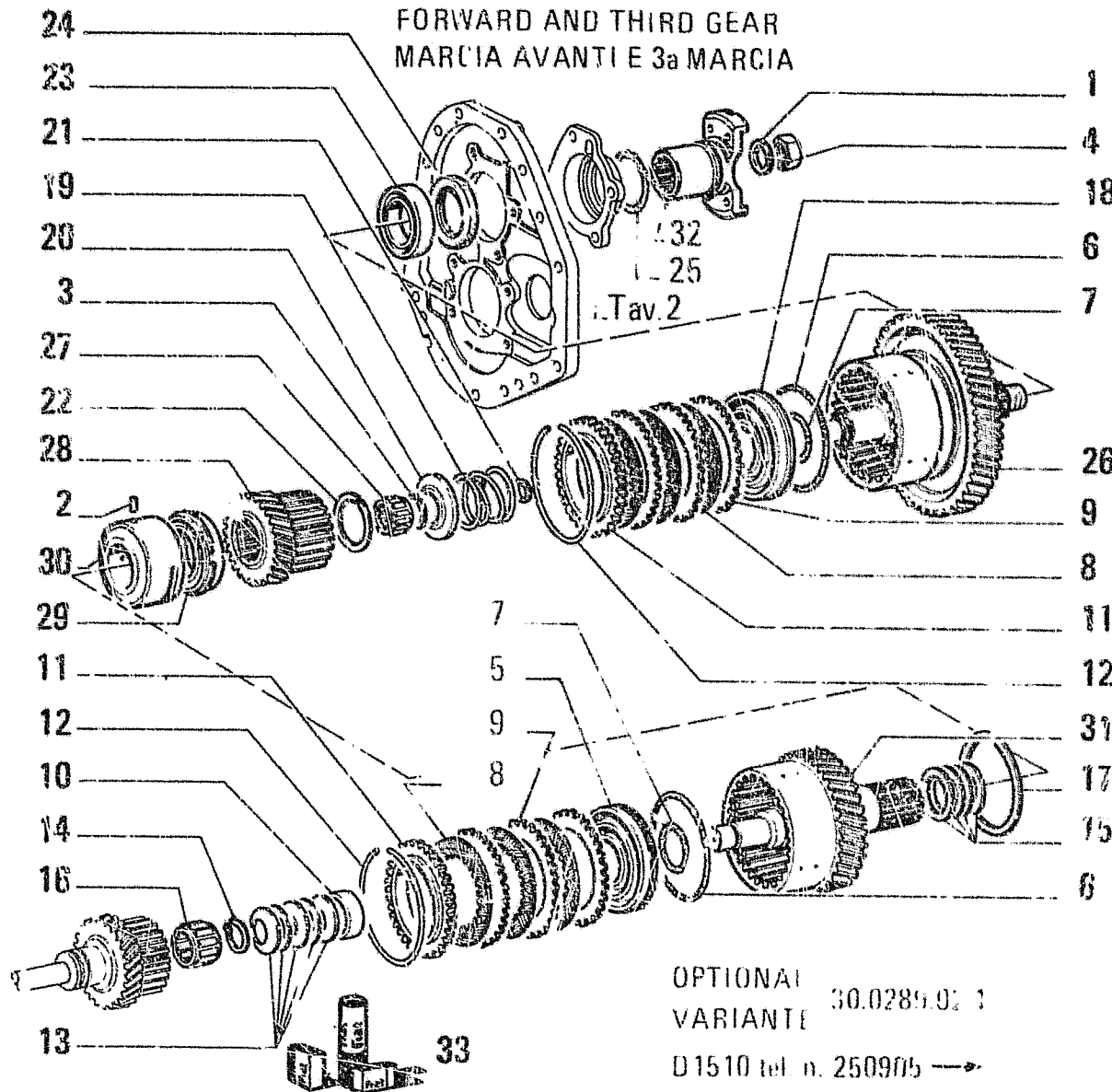

ITEM	PART NUMBER	QTY	TRANS CODE	DESCRIPTION	DESCRIZIONE
1	70673871	1	121R	WASHER	ROSETTA
2	79063942	1	80F	PIN	PERNO
3	70926000	1	51A	LOCKRING	ANELLO DI SICUREZZA
4	73109871	1	10D	NUT	DADO
5	73118085	1	130P	PLUNGER	PISTONCINO
6	73118086	2	123C	SEAL ASSY	GUARNIZIONE TENUTA FRONTALE
7	73118087	2	123G	SEAL ASSY	GUARNIZIONE TENUTA FRONTALE
8	73118088	14	60D	DISC	DISCO
9	73118089	14	60D	DISC	DISCO
10	73118090	1	75D	SPACER	DISTANZIALE
11	73118091	2	60D	DISC	DISCO
12	73118092	2	45A	RING	ANELLO
13	73118093	5	100M	SPRING	MOLLA
14	73118094	1	51A	LOCKRING	ANELLO DI SICUREZZA
15	73118096	4	45A	RING	ANELLO
16	73118097	1	341C	BEARING	CUSCINETTO
17	73118098	1	51A	LOCKRING	ANELLO DI SICUREZZA
18	73118106	1	130P	PLUNGER	PISTONCINO
19	73118107	1	100M	SPRING	MOLLA
20	73118108	1	60S	CUP	SCODELLINO
21	73118136	1	45A	RING	ANELLO
22	79051090	1	51A	LOCKRING	ANELLO DI SICUREZZA
23	79030209	1	341C	BEARING	CUSCINETTO
24	79030210	1	123G	SEAL ASSY	GUARNIZIONE TENUTA FRONTALE
25	14463880	1	158G	O-RING 3,53x34,52	GUARNIZIONE O-R 3,53x34,52
26	79030225	1	16A	SHAFT	ALBERO
27	79030226	1	341C	BEARING	CUSCINETTO

79064264

TRANSMISSION - CAMBIO DI VELOCITA' - BOITE DE VITESSES - WECHSELGETRIEBE -- CAMBIO DE VELOCIDADES

9

B2 01/1A 9

N.T.R. 205 - 30.09.1991
604.01.081.06

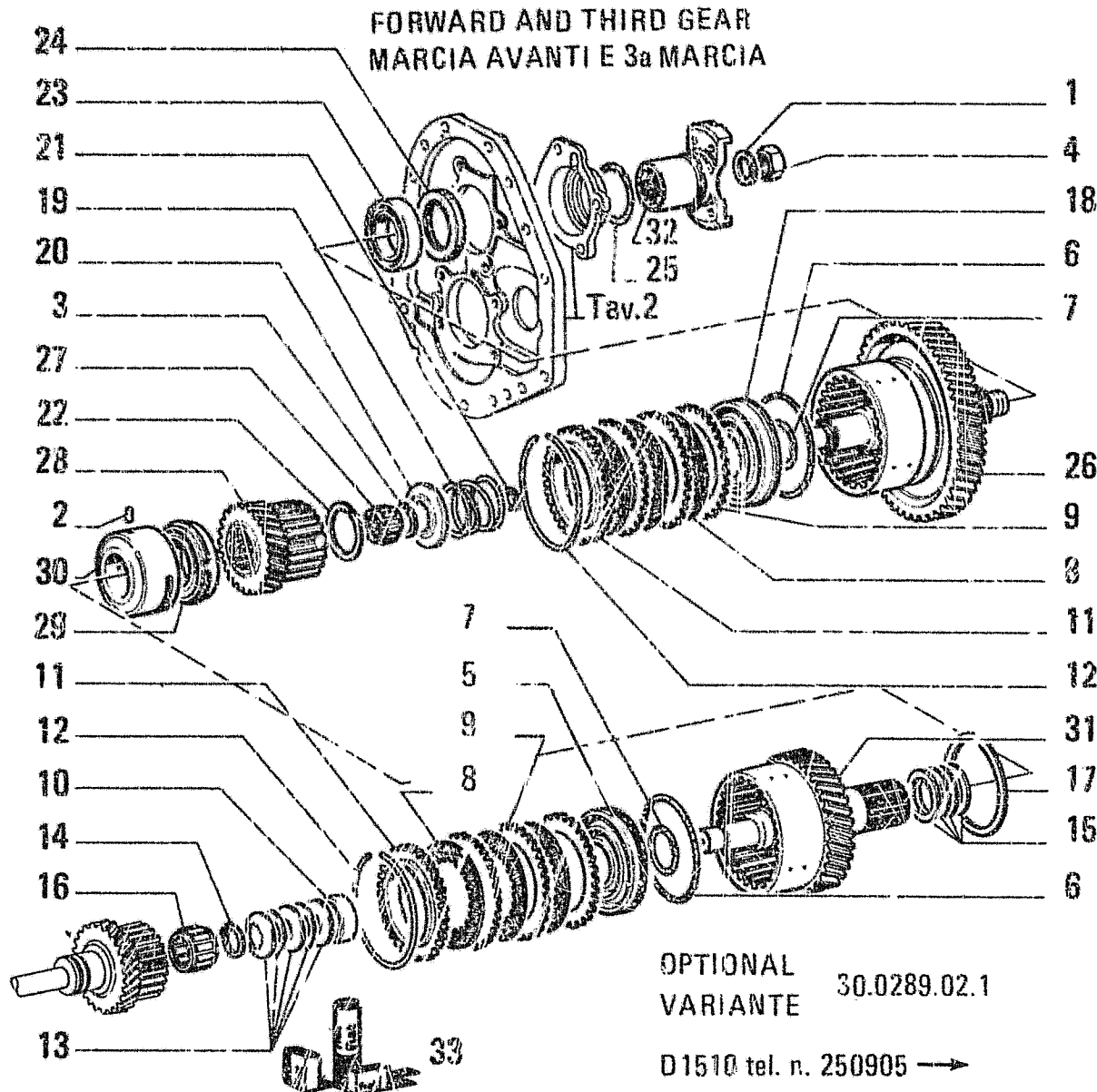

ITEM	PART NUMBER	QTY	TRANS CODE	DESCRIPTION	DESCRIZIONE
28	790600J5	1	50I GEAR		INGRANAGGIO
29	79030230	1	341C BEARING		CUSCINETTO
30	79064245	1	135M HUB		MOZZO
31	79030232	1	16A SHAFT		ALBERO
32	79031240	1	70F FLANGE		FLANGIA
33	79055160	1	1K KIT SEE PAGE 9		KIT VED. PAG.9

TRANSMISSION - CAMBIO DI VELOCITA' - BOITE DE VITESSES - WECHSELGETRIEBE - CAMBIO DE VELOCIDADES

79064264

9

B2.01/1A

9

N.T.R. 205 - 30.09.1991
604.01.081.06

H5

OPTIONAL
VARIANTE 30.0289.02.1

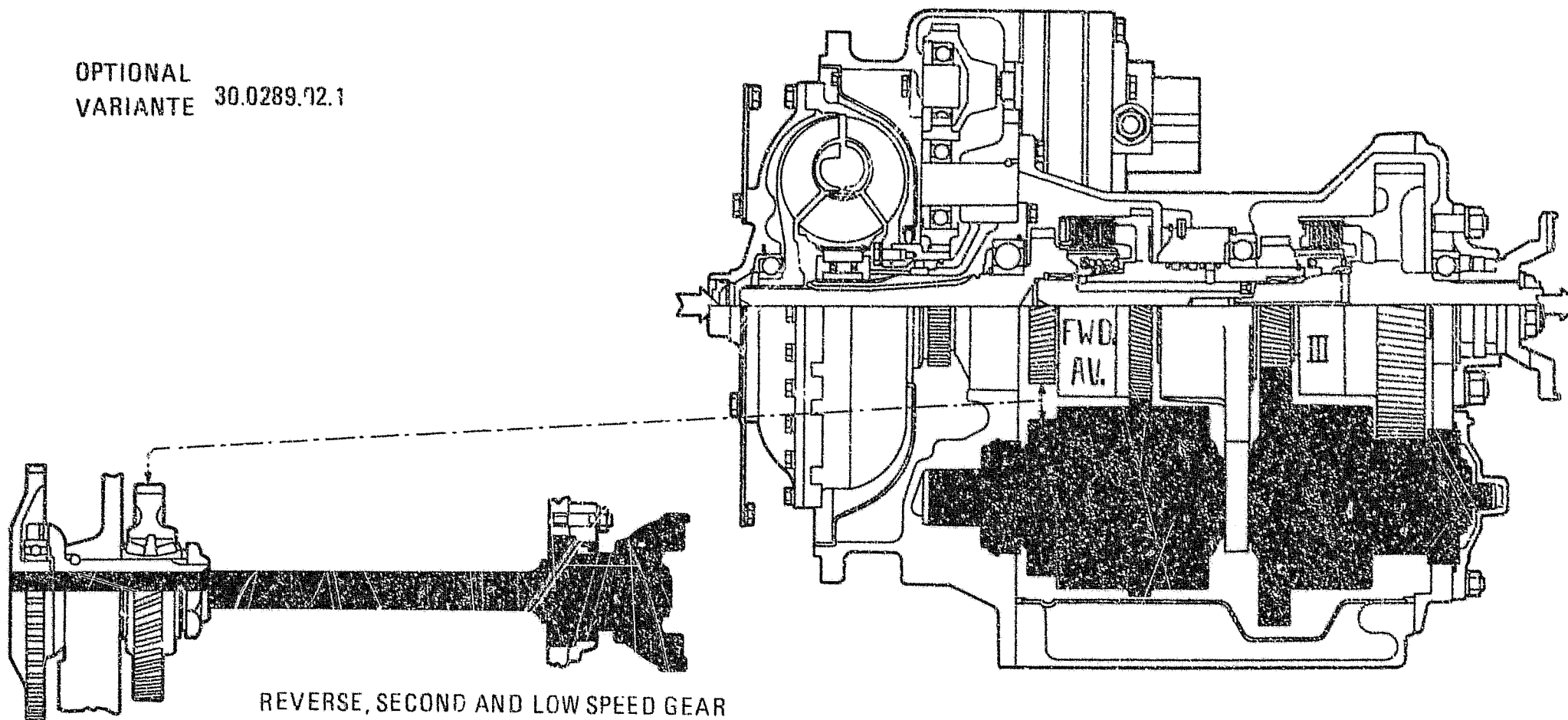

REVERSE, SECOND AND LOW SPEED GEAR
RETROMARCIA, 2^a E 1^a MARCIA

79064264

TRASMISSION – CAMBIO DI VELOCITA' – BIOTE DE VITESSES – WECHSELGETRIEBE – CAMBIO DE VELOCIDADES

B2.01/1A

10

N.T.R. 205 - 30.09.1991
604.01.081.06

H6

OPTIONAL
VARIANTE 30.0289.02.1

D1510 tel. n. 250905 →

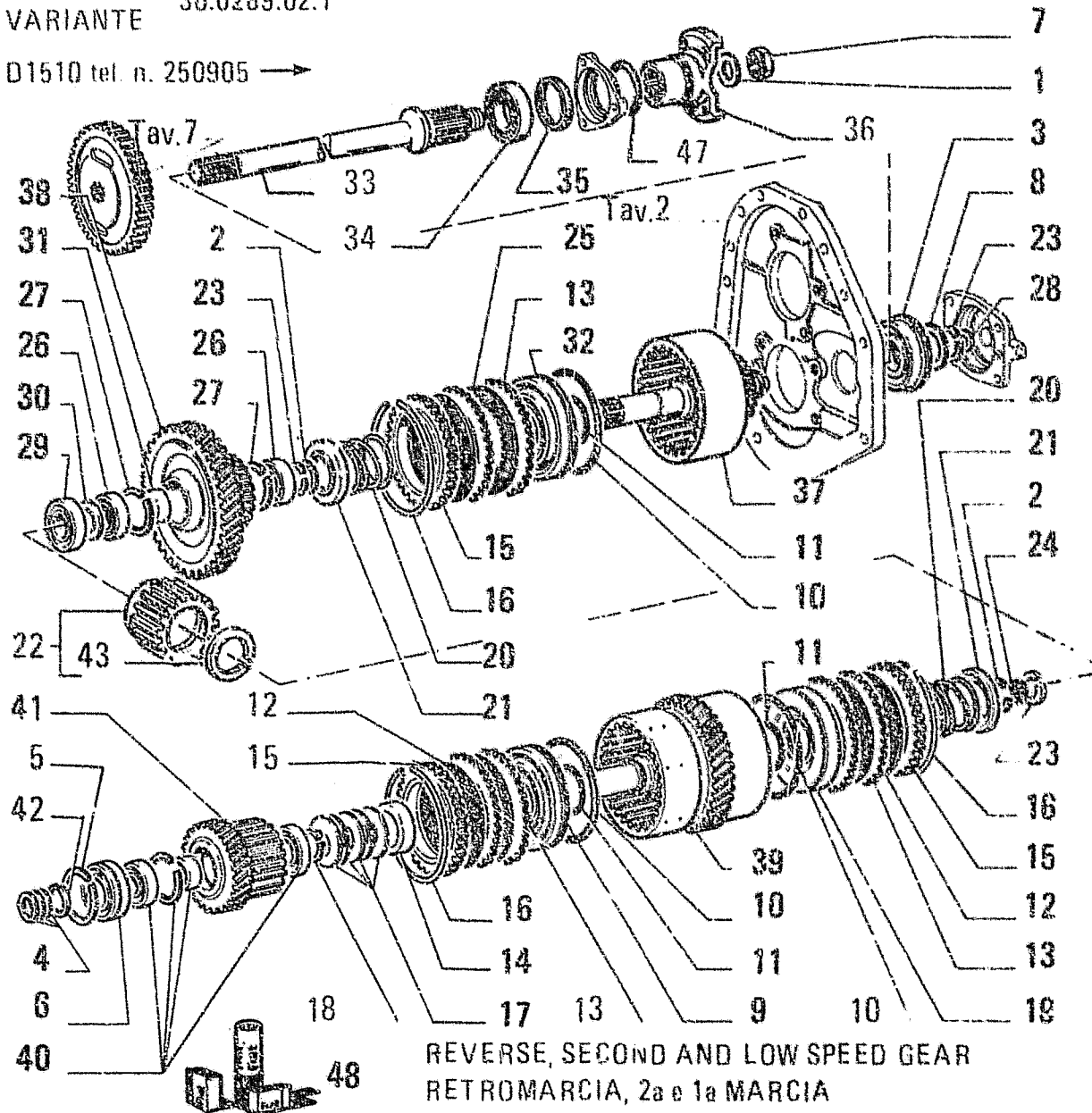

REVERSE, SECOND AND LOW SPEED GEAR
RETROMARCIA, 2a e 1a MARCIA

FIATALLIS FD7

B2.01/ 1A TAV.11 PAG.1

ITEM	PART NUMBER	QTY	TRANS CODE	DESCRIPTION	DESCRIZIONE
1	70673871	1	131R	WASHER	ROSETTA
2	70926000	2	51A	LOCKRING	ANELLO DI SICUREZZA
3	73132784	1	341C	BEARING	CUSCINETTO
4	71004926	3	45A	RING	ANELLO
5	71004961	1	51A	LOCKRING	ANELLO DI SICUREZZA
6	71004962	1	341C	BEARING	CUSCINETTO
7	73109871	1	10D	NIJT	DADO
8	73118058	1	131R	WASHER	ROSETTA
9	73118085	1	130P	PLUNGER	PISTONCINO
10	73118086	3	123G	SEAL ASSY	GUARNIZIONE TENUTA FRONTALE
11	73118087	3	123G	SEAL ASSY	GUARNIZIONE TENUTA FRONTALE
12	73118088	14	60D	DISC	DISCO
13	73118089	22	60D	DISC	DISCO
14	73118090	1	75D	SPACER	DISTANZIALE
15	73118091	3	60D	DISC	DISCO
16	73118092	3	45A	RING	ANELLO
17	73118093	5	100M	SPRING	MOLLA
18	73118094	1	51A	LOCKRING	ANELLO DI SICUREZZA
19	73118106	1	130P	PLUNGER	PISTONCINO
20	73118107	2	100M	SPRING	MOLLA
21	73118108	2	60S	CUP	SCODELLINO
22	79052636	1	135M	HUB - ASSEMBLY	MOZZO - COMPLETO
23	73118110	3	51A	LOCKRING	ANELLO DI SICUREZZA
24	73118111	1	341C	BEARING	CUSCINETTO
25	73118133	8	60D	DISC	DISCO
26	73118134	2	341C	BEARING	CUSCINETTO
27	73118135	2	51A	LOCKRING	ANELLO DI SICUREZZA

79064264

9

TRANSMISSION - CAMBIO DI VELOCITA' - BOITE DE VITESSES - WECHSELGETRIEBE - CAMBIO DE VELOCIDADES

B2.01/1A

11

N.T.R. 205 - 30.09.1991
604.01.081.06

H7

OPTIONAL
VARIANTE 30.0289.02.1

D151G rel n 250905 →

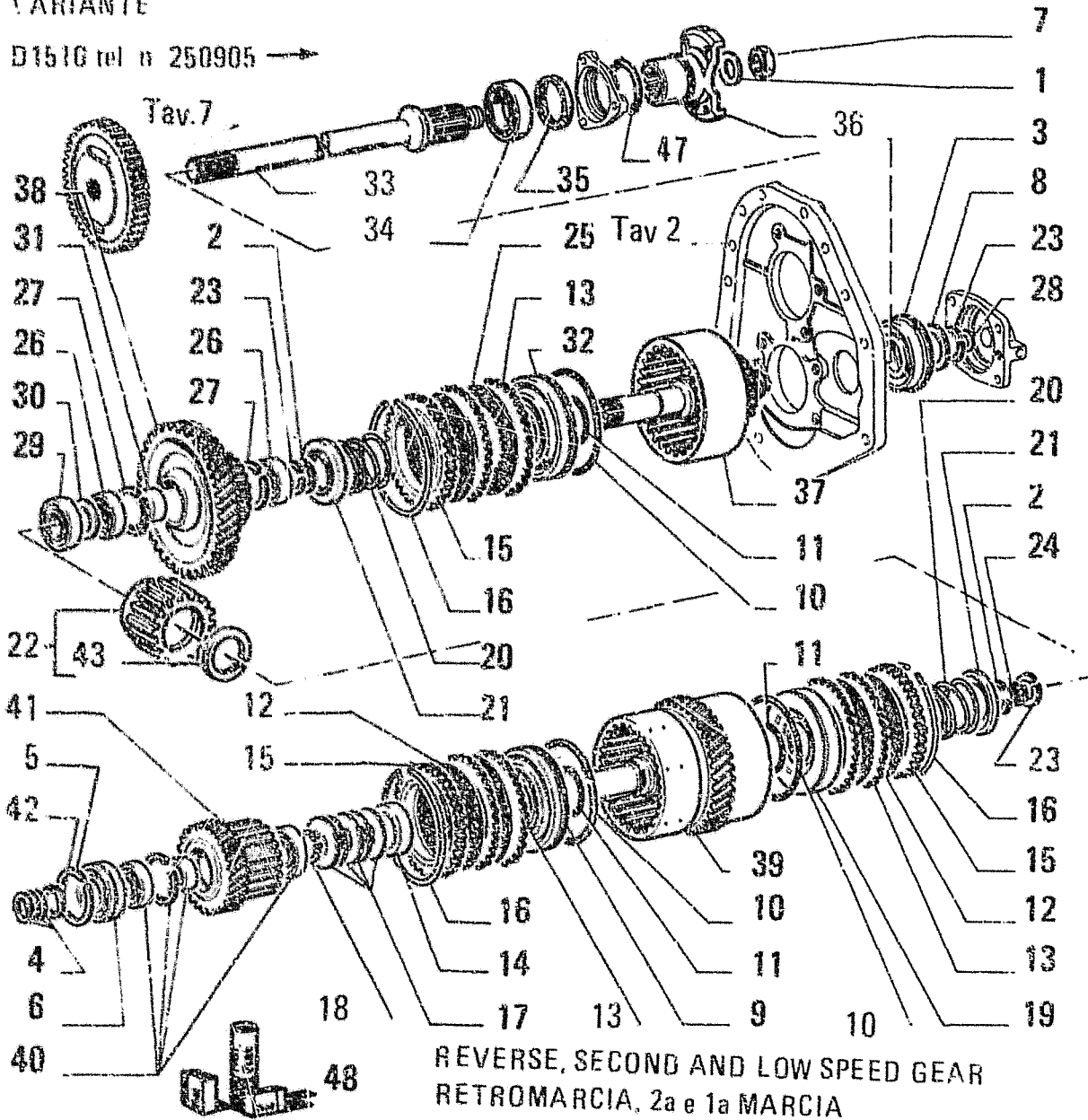

FIATALLIS FD7

B2.01/ 1A TAV.11 PAG.2

ITEM	PART NUMBER	QTY	TRANS CODE	DESCRIPTION	DESCRIZIONE
28	73118136	1	45A	RING	ANELLO
29	73118137	1	341C	BEARING	CUSCINETTO
30	73118138	1	75D	SPACER	DISTANZIALE
31	73118139	1	75D	SPACER	DISTANZIALE
32	73118236	1	130P	PLUNGER	PISTONCINO
33	79030218	1	16A	SHAFT	ALBERO
34	79030219	1	341C	BEARING	CUSCINETTO
35	79030222	1	123G	SEAL ASSY	GUARNIZIONE TENUTA FRONTALE
36	79030223	1	70F	FLANGE	FLANGIA
37	79030228	1	16A	SHAFT	ALBERO
38	79060006	1	50I	GEAR	INGRANAGGIO
39	79030233	1	16A	SHAFT	ALBERO
40	79030234	1	341C	BEARING	CUSCINETTO
41	79060008	1	50I	GEAR	INGRANAGGIO
42	79030236		198S	SHIM	SPESSORE
	79030237		198S	SHIM	SPESSORE
	79030238		198S	SHIM	SPESSORE
	79030239		198S	SHIM	SPESSORE
	79030240		198S	SHIM	SPESSORE
43	79064449	1	51A	LOCKRING	ANELLO DI SICUREZZA
47	14463880	1	158G	O-RING 3.53x34.52	GUARNIZIONE O R 3.53x34.52
48	79055160	1	TK	KIT SEE PAGE 9	KIT VED. PAG 9

REVERSE, SECOND AND LOW SPEED GEAR
RETROMARCIA, 2a e 1a MARCIA

79064264.

TRANSMISSION - CAMBIO DI VELOCITA' - BOITE DE VITESSES - WECHSELGETRIEBE - CAMBIO DE VELOCIDADES

9 B2.01 1A 11
N.T.R. 205 - 30.09.1991
604.01.081.06

H8

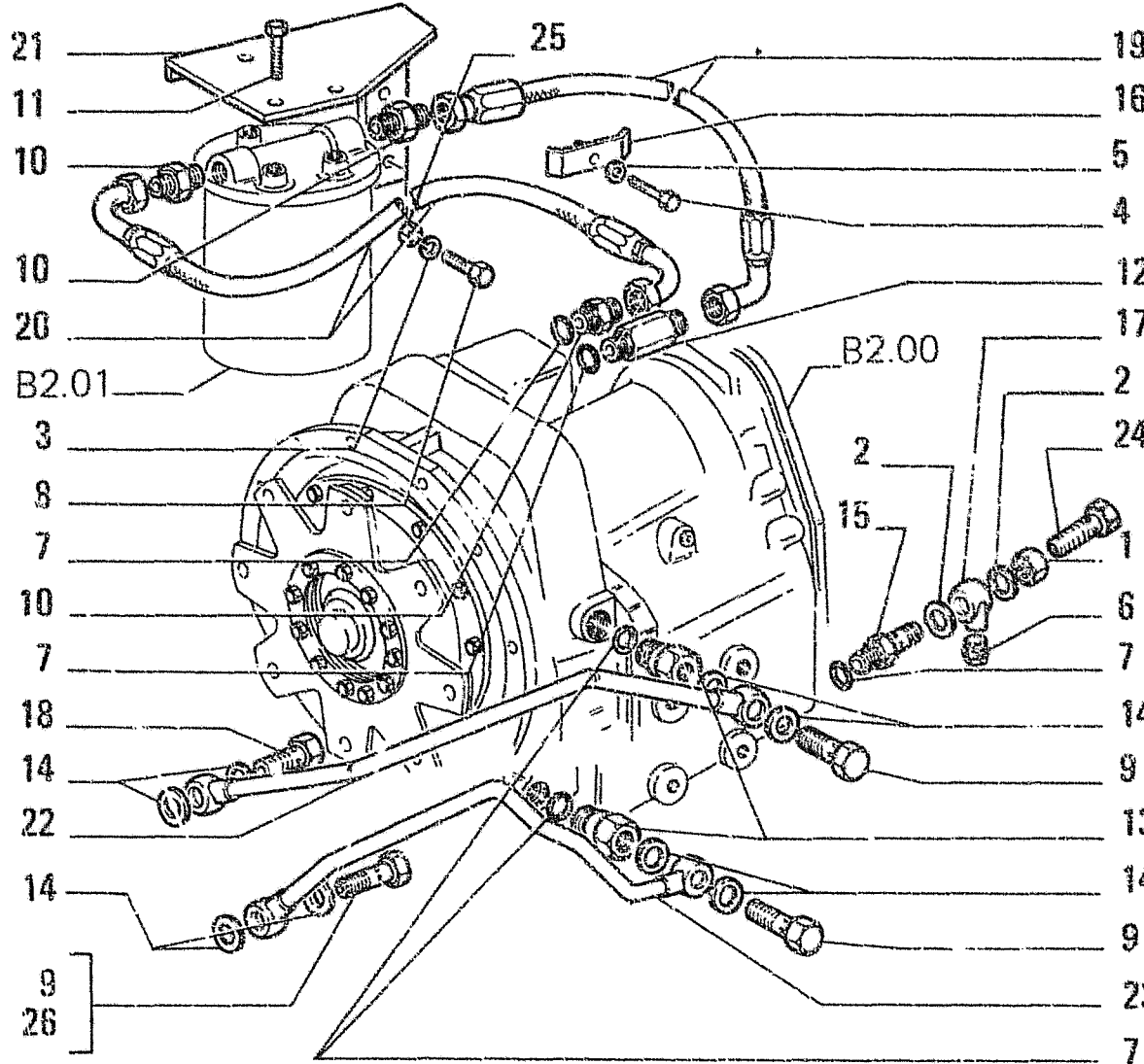

ITEM	PART NUMBER	QTY	TRANS CODE	DESCRIPTION	DESCRIZIONE
1	10183717	2	56T	DRAIN PLUG 28x1,5x18 C1158	TAPPO DI SCARICO 28x1,5x18 C1158
2	10296260	4	122G	SEAL 28,3x36	GUARNIZIONE 28,3x36
3	10518871	2	170R	LOCKWASHER 10x2,5 C1510	ROSETTA EL. 10x2,5 C1510
4	11107031	1	40V	SCREW 10x1,5x45 C1165	VITE 10x1,5x45 C1165
5	12638601	1	131R	WASHER 10,2x18 C1165	ROSETTA 10,2x18 C1165
6	14326213	1	56T	DRAIN PLUG 22x1,5x21	TAPPO DI SCARICO 22x1,5x21
7	14457781	2	158G	O-RING 2,62x23,47	GUARNIZIONE O-R 2,62x23,47
		1	158G	O-RING 2,62x23,47 C1158	GUARNIZIONE O-R 2,62x23,47 C1158
		2	158G	O-RING 2,62x23,47 C1510	GUARNIZIONE O-R 2,62x23,47 C1510
8	11106631	2	40V	SCREW 10x1,5x35 D1165	VITE 10x1,5x35 D1165
		2	40V	SCREW 10x1,5x35 C1510	VITE 10x1,5x35 C1510
	15970731	2	40V	SCREW 10x1,25x25 C1165	VITE 10x1,25x25 C1165
9	79013310	2	50B	FILLER PLUG	BOCCHETTONE INRODUZIONE
		1	20R	FITTING C1510	RACCORDO C1510
10	79013319	3	20R	FITTING C1510	RACCORDO C1510
11	79013324	3	40V	SCREW C1510	VITE C1510
12	79018945	1	20R	FITTING C1510	RACCORDO C1510
13	76007483	2	20R	FITTING D1505	RACCORDO D1505
	79022153	2	20R	FITTING C1505	RACCORDO C1505
14	79022167	8	133R	SEAL	ROSETTA DI TENUTA
15	79024729	1	26R	FITTING C1158	RACCORDO C1158
16	79025182	1	225S	BRACKET C1165	STAFFA C1165
17	79028146	1	21R	BANJO UNION D1585	RACCORDO ORIENTABILE D1585

TRANSMISSION LUBRICATION SYSTEM - LUBRIFICAZIONE CAMBIO - GRAISSAGE DE B.V. -
GETRIEBESCHMIERUNG - ENGRASE DEL CAMBIO

1 B2.06 1

N.T.R. 205 - 30.09.1991
684.01.081.06

H9

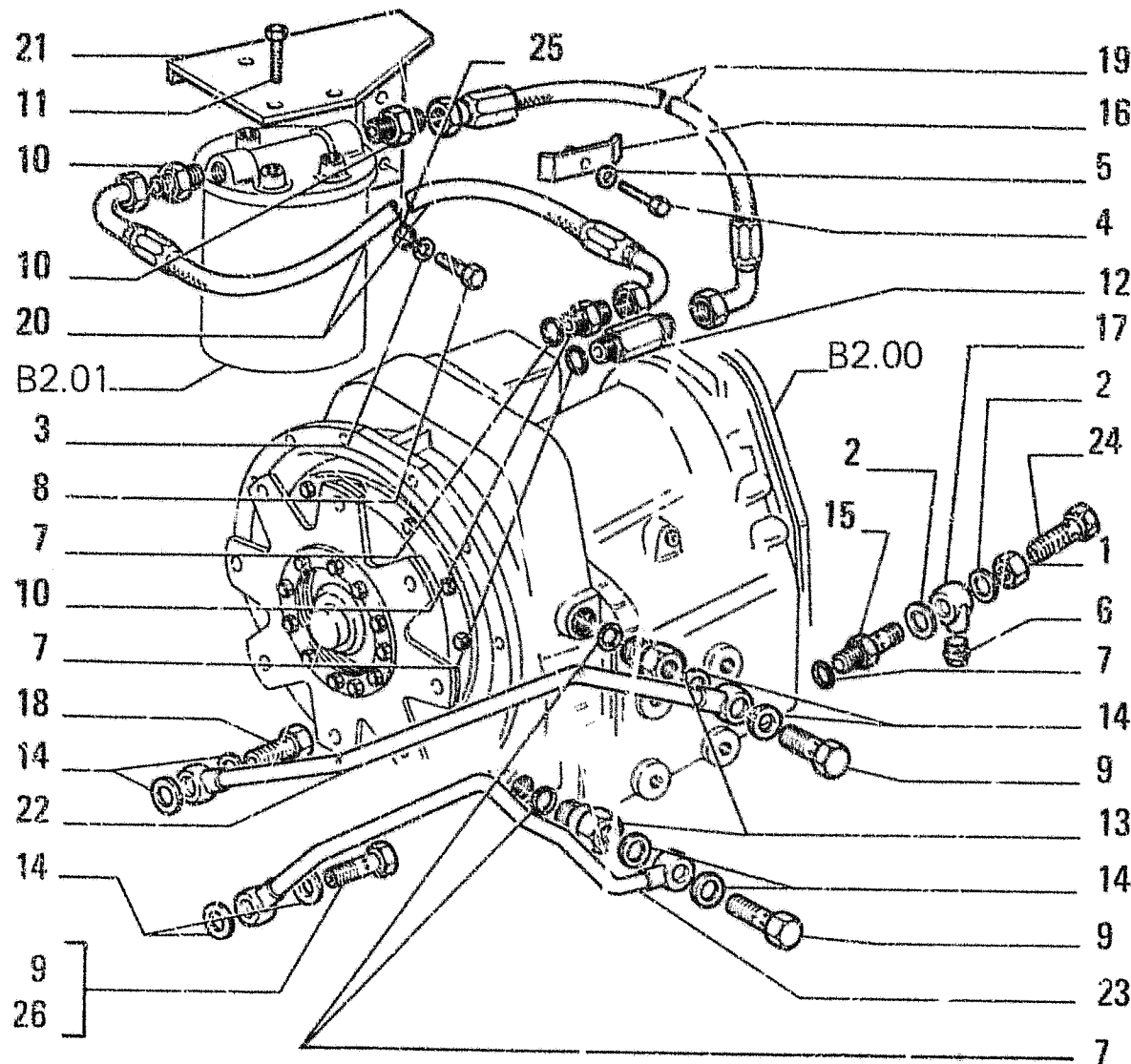

ITEM	PART NUMBER	QTY	TRANS CODE	DESCRIPTION	DESCRIZIONE
17	79028382	1	21R	BANJO UNION C1505	RACCORDO ORIENTABILE C1585
18	79028983	1	20R	FITTING	RACCORDO
19	79035760	1	192T	HOSE ASSY C1510	TUBO FLESS.C/RACCORDI C1510
20	79035763	1	192T	HOSE ASSY C1510	TUBO FLESS.C/RACCORDI C1510
21	79036733	1	225S	BRACKET C1510	STAFFA C1510
22	79038143	1	193T	TUBE C1510	TUBO RIGIDO C1510
	79049511	1	193T	TUBE D1510	TUBO RIGIDO D1510
23	79038145	1	193T	TUBE	TUBO RIGIDO
24	10182217	1	20R	FITTING 28x1,5x19 D1506	RACCORDO 28x1,5x19 D1506
	79043444	1	20R	FITTING D1158	RACCORDO D1158
		1	20R	FITTING C1506	RACCORDO C1506
25	11701721	2	10D	NUT 10x1,5x8 D1165	DADO 10x1,5x8 D1165
		2	10D	NUT 10x1,5x8 C1510	DADO 10x1,5x8 C1510
26	79022154	1	20R	FITTING D1510	RACCORDO D1510

TRANSMISSION LUBRICATION SYSTEM - LUBRIFICAZIONE CAMBIO - GRAISSAGE DE B.V. -
 GETRIEBESCHMIERUNG - ENGRASE DEL CAMBIO

1

B2.06

1

N.T.R. 205 - 30.09.1991
 604.01.081.06

H10

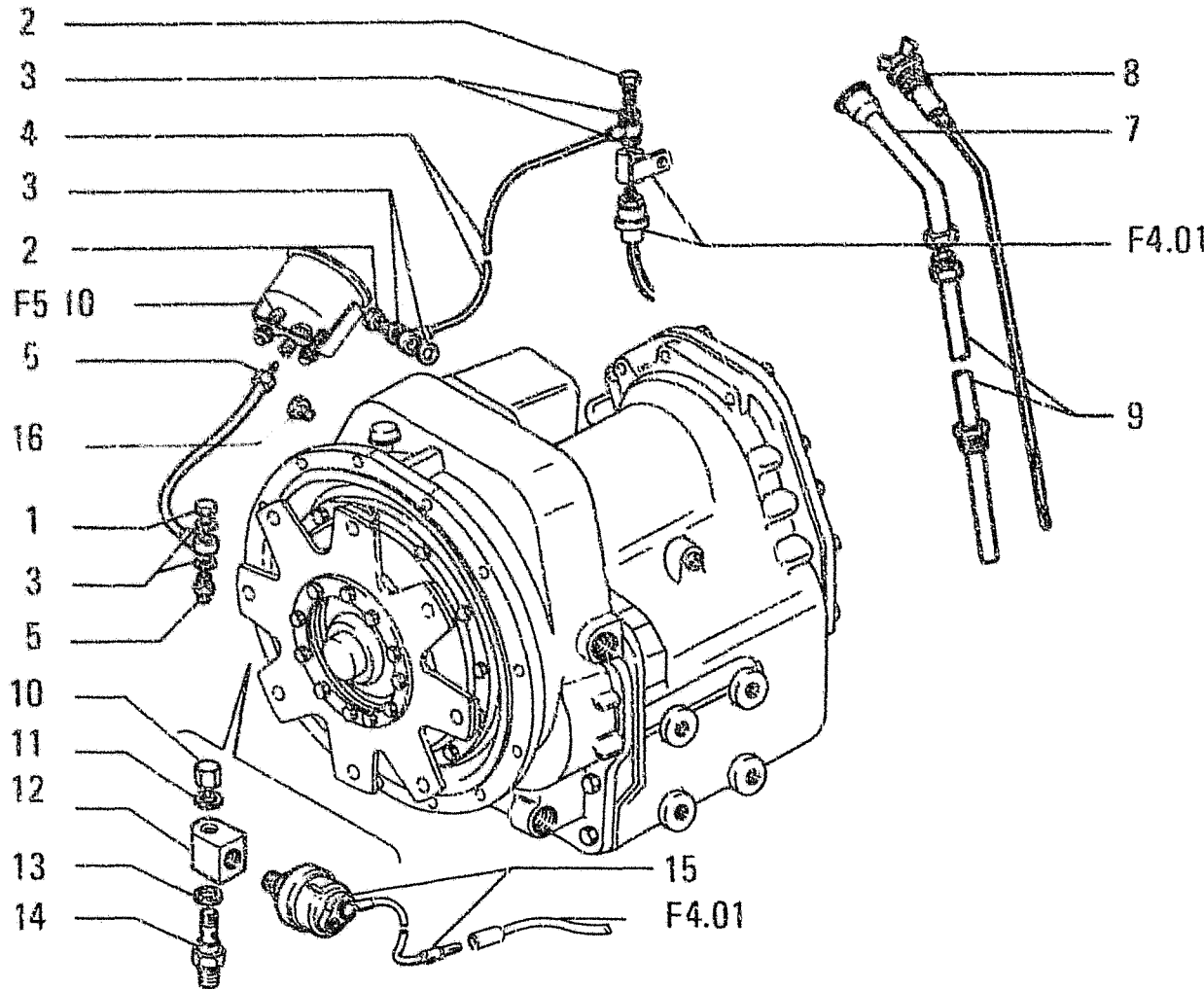

ITEM	PART NUMBER	QTY	TRANS CODE	DESCRIPTION	DESCRIZIONE
1	11902017	1	50T	PLUG 8x1,25x11 C1510	TAPPO 8x1,25x11 C1510
2	11903717	2	20R	FITTING 8x1,25x16 C2954	RACCORDO 8x1,25x16 C2954
3	14330260	4	120G	GASKET 8,2x12 C2954	GUARNIZIONE PIANA 8,2x12 C2954
		2	120G	GASKET 8,2x12 C1510	GUARNIZIONE PIANA 8,2x12 C1510
4	79004919	1	193T	TUBE C1510	TUBO RIGIDO C1510
	79049513	1	193T	TUBE D1510	TUBO RIGIDO D1510
		1	193T	TUBE C2954	TUBO RIGIDO C2954
5	79014718	1	20R	FITTING C1510	RACCORDO C1510
6	79014722	1	193T	TUBE C1510	TUBO RIGIDO C1510
7	79024738	1	193T	TUBE - UP 5R	TUBO RIGIDO - SUPERIORE
8	79028190	1	53I	DIPSTICK W/ CAP	TAPPO DI INTRODUZIONE OLIO CON ASTA LIVELLO
9	79028193	1	193T	TUBE - LOWER	TUBO RIGIDO - INFERIORE
10	10183217	1	50T	PLUG 12x1,5x14 D1510	TAPPO 12x1,5x14 D1510
11	10296160	1	120G	GASKET 12,2x18 D1510	GUARNIZIONE PIANA 12,2x18 D1510
12	79053321	1	20R	FITTING D1510	RACCORDO D1510
13	10257060	1	120G	GASKET 16,2x22 D1510	GUARNIZIONE PIANA 16,2x22 D1510
14	79053320	1	20R	FITTING D1510	RACCORDO D1510
15	79051192	1	160T	SENDING UNIT TRANSMISSION FLUID PRESSURE D1510	TRASMETTITORE TRANSMISSION FLUID PRESSURE D1510
16	10300911	1	50T	PLUG D2954	TAPPO D2954

TRANSMISSION LUBRICATION SYSTEM - LUBRIFICAZIONE CAMBIO - GRAISSAGE DE B.V. -
GETRIEBESCHMIERUNG - ENGRASE DEL CAMBIO

B2.06

2

N.T.R. 191 - 20.02.1990

604.01.081.04

H11

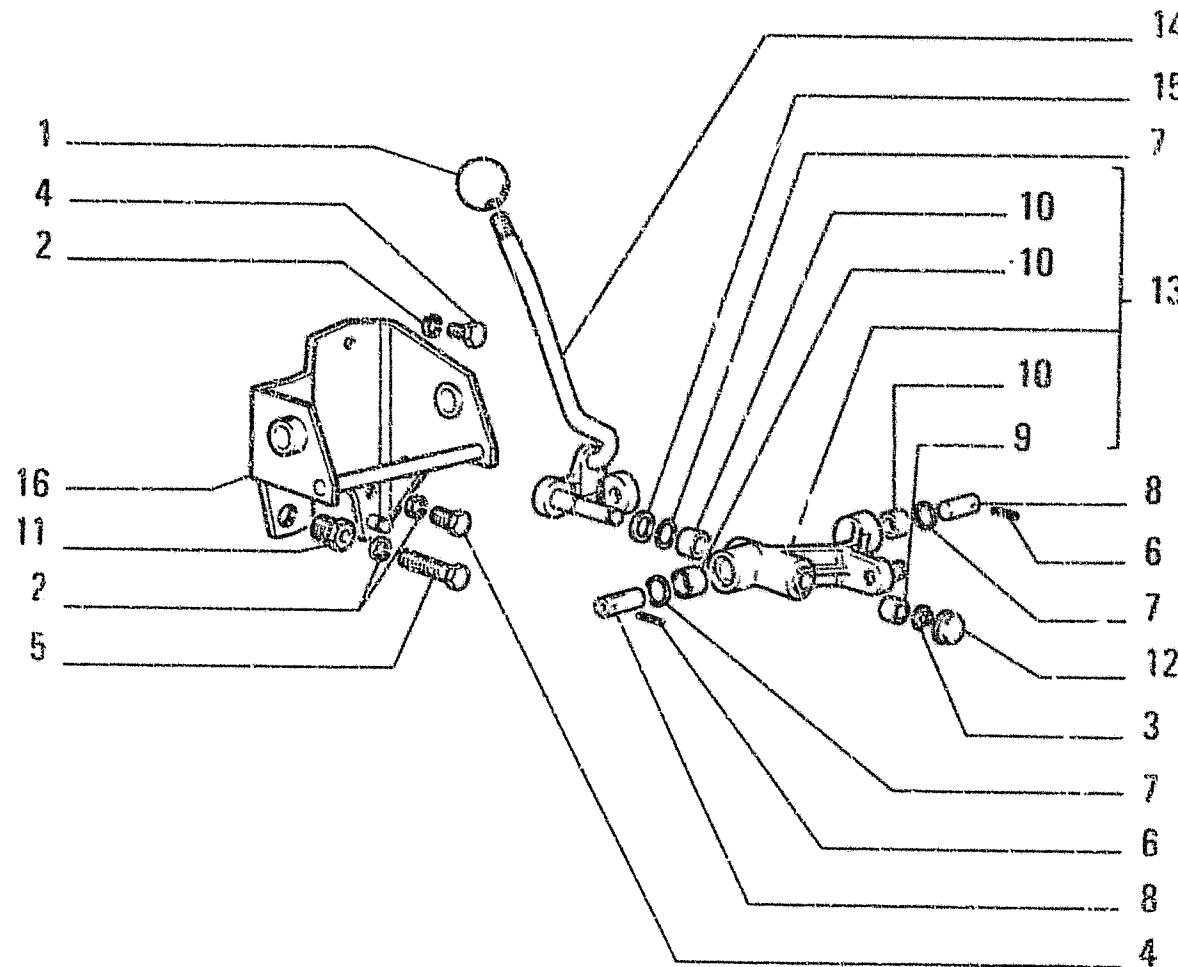

ITEM	PART NUMBER	QTY	TRANS CODE	DESCRIPTION	DESCRIZIONE
1	4970504	1	2SI	HANDGRIP	IMPUGNATURA
2	10571871	3	132R	LOCKWASHER 10,2x2,2	ROSETTA DI SICUREZZA 10,2x2,2
3	11088076	1	51A	LOCKRING 9x18,5	ANELLO DI SICUREZZA 9x18,5
4	11103031	2	40V	SCREW 10x1,5x18	VITE 10x1,5x18
5	11108631	1	40V	SCREW 10x1,5x35	VITE 10x1,5x35
6	12181370	2	20GS	PIN 4,4x30	SPINA 4,4x30
7	14457280	3	158G	O-RING 2,62x15,54	GUARNIZIONE O-R 2,62x15,54
8	79005594	2	80P	PIN	PERNO
9	79005596	1	95B	BUSHING	BOCCOLA
10	79005597	3	95B	BUSHING	BOCCOLA
11	79005598	1	40V	SCREW	VITE
12	79005599	1	60S	CUP	SCODELLINO
13	79005607	1	45L	LEVER - ASSEMBLY	LEVA - COMPLETO
14	79005610	1	45L	LEVER C1574	LEVA C1574
	79043491	1	45L	LEVER D1574	LEVA D1574
15	79006339	1	75D	SPACER	DISTANZIALE
16	79022777	1	30GS	SUPPORT	SUPPORTO

GEARSHIFT OUTER CONTROLS - COMANDI ESTERNI CAMBIO DI VELOCITA' - COMMANDES
 EXTERIEURES DE BOITE DE VITESSES - AEUSSERE GETRIEBESCHALTUNG - VARILLAJE DEL CAMBIO
 DE VELOCIDADES

1 B2.07
 N.T.R. 158 - 13.03.1987
 604.01.081.03

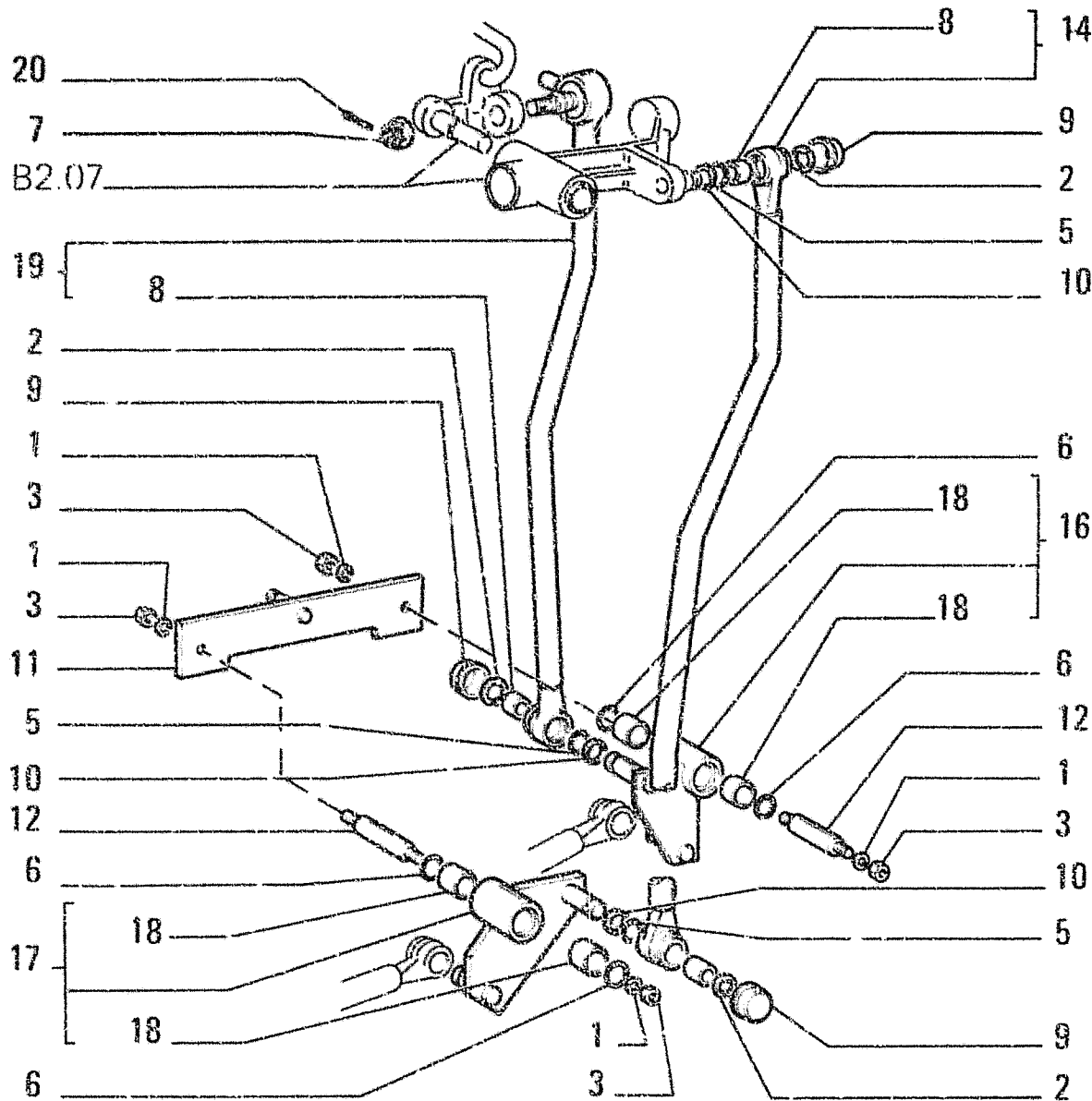

FIATALLIS FD7

B2.10 TAV. 1 PAG.1

ITEM	PART NUMBER	QTY	TRANS CODE	DESCRIPTION	DESCRIZIONE
1	10571871	4	132R	LOCKWASHER 10,2x2,2	ROSETTA DI SICUREZZA 10,2x2,2
2	11088076	3	51A	LOCKRING 9x18,5	ANELLO DI SICUREZZA 9x18,5
3	11701721	4	10D	NUT 10x1,5x8	DADO 10x1,5x8
5	14457080	3	158G	O-RING 2,62x12,37	GUARNIZIONE O-R 2,62x12,37
6	14457280	4	158G	O-RING 2,62x15,54	GUARNIZIONE O-R 2,62x15,54
7	16105621	1	10D	NUT 8x1,25x9,5	DADO 8x1,25x9,5
8	79005596	1	95B	BUSHING	BOCCOLA
9	79005599	3	60S	CUP	SCODELLINO
10	79005601	3	75D	SPACER	DISTANZIALE
11	79013633	1	300S	SUPPORT - REAR	SUPPORTO - POSTERIORE
12	79018505	2	80P	PIN	PERNO
14	79026649	1	142T	TIEROD - UPPER ASSEMBLY	TIRANTE - SUPERIORE COMPLETO
16	79027925	1	45L	LEVER - ASSEMBLY	LEVA - COMPLETO
17	79027926	1	45L	LEVER - REAR ASSEMBLY	LEVA - POSTERIORE COMPLETO
18	79027927	2	95B	BUSHING	BOCCOLA
19	79033634	1	142T	TIEROD - UPPER ASSEMBLY	TIRANTE - SUPERIORE COMPLETO
20	10734401	1	270C	COTTER PIN 1,7x28,5	COPIGLIA 1,7x28,5

GEARSHIFT INNER CONTROLS - COMANDI INTERNI CAMBIO DI VELOCITA' - COMMANDES INTERNES DE BOITE DE VITESSES - INNERE GETRIEBESCHALTUNG - BARRAS DEL CAMBIO DE VELOCIDADES

1

B2.10

1

N.T.R. 205 - 30.09.1991
604.01.081.06

H13

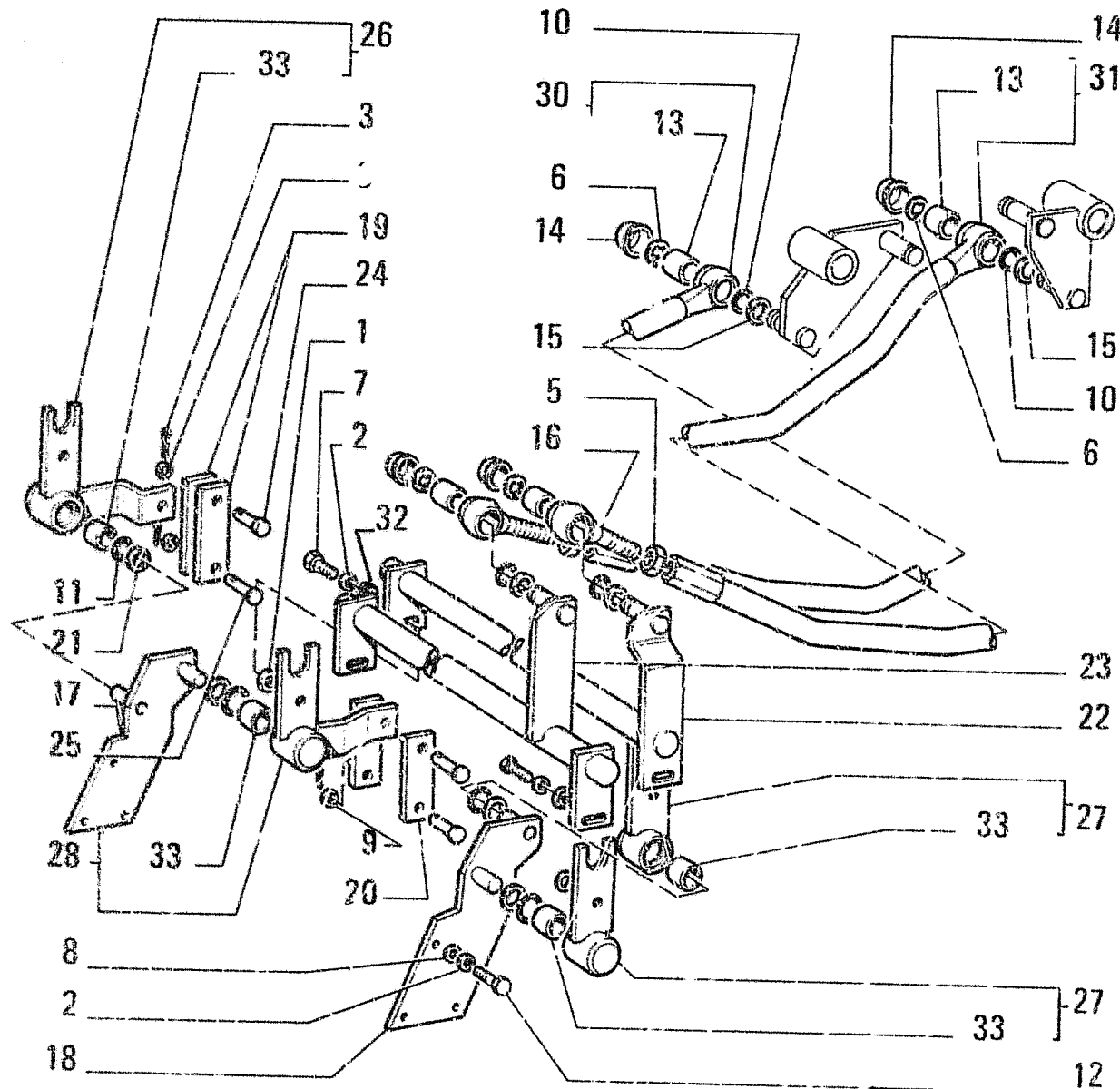

FIATALLIS FD7

ITEM	PART NUMBER	QTY	TRANS CODE	DESCRIPTION	DESCRIZIONE
1	4967724		198S SHIM		SPESSORE
2	10571871	10	132R LOCKWASHER 10,2x2,2		ROSETTA DI SICUREZZA 10,2x2,2
3	10734201	4	270C COTTER PIN 1,7x18,5		COPIGLIA 1,7x18,5
5	10791221	2	10D NUT 11x1,25x7		DADO 11x1,25x7
6	11088076	4	51A LOCKRING 9x18,5		ANELLO DI SICUREZZA 9x18,5
7	11106231	4	40V SCREW 10x1,5x25		VITE 10x1,5x25
8	12638601	8	131R WASHER 10,2x18		ROSETTA 10,2x18
9	12646701	2	131R WASHER 8,15x20		ROSETTA 8,15x20
10	14457080	4	158G O-RING 2,62x12,37		GUARNIZIONE O-R 2,62x12,37
11	14457280	4	158G O-RING 2,62x15,54		GUARNIZIONE O-R 2,62x15,54
12	15070931	6	40V SCREW 10x1,25x35		VITE 10x1,25x35
13	79005596	1	95B BUSHING		BOCCOLA
14	79005599	4	60S CUP		SCODELLINO
15	79005601	4	75D SPACER		DISTANZIALE
16	79005602	2	62E TIEROD HEAD		ESTREMITA' DEL TIRANTE
17	79013628	1	300S SUPPORT - RIGHT		SUPPORTO - DESTRO
18	79013631	1	300S SUPPORT - LEFT		SUPPORTO - SINISTRO
19	79013637	2	60B SHACKLE		BISCOTTINO
20	79013638	2	60B SHACKLE		BISCOTTINO
21	79013702	4	75D SPACER		DISTANZIALE
22	76016328	1	16A SHAFT D2910		ALBERO D2910
	79022760	1	16A SHAFT C2910		ALBERO C2910
23	79022764	1	16A SHAFT		ALBERO
24	79022768	2	80P PIN		PERNO
25	79025361	2	80P PIN		PERNO
26	79027929	1	45L LEVER - RIGHT ASSEMBLY		LEVA - DESTRO COMPLETO
27	79027931	2	45L LEVER - LEFT ASSEMBLY		LEVA - SINISTRO COMPLETO

GEARSHIFT INNER CONTROLS - COMANDI INTERNI CAMBIO DI VELOCITA' - COMMANDES INTERNES DE
BOITE DE VITESSES - INNERE GETRIEBESCHALTUNG - BARRAS DEL CAMBIO DE VELOCIDADES

B2.10

2

N.T.R. 205 - 30.09.1991
604.01.081.06

H14

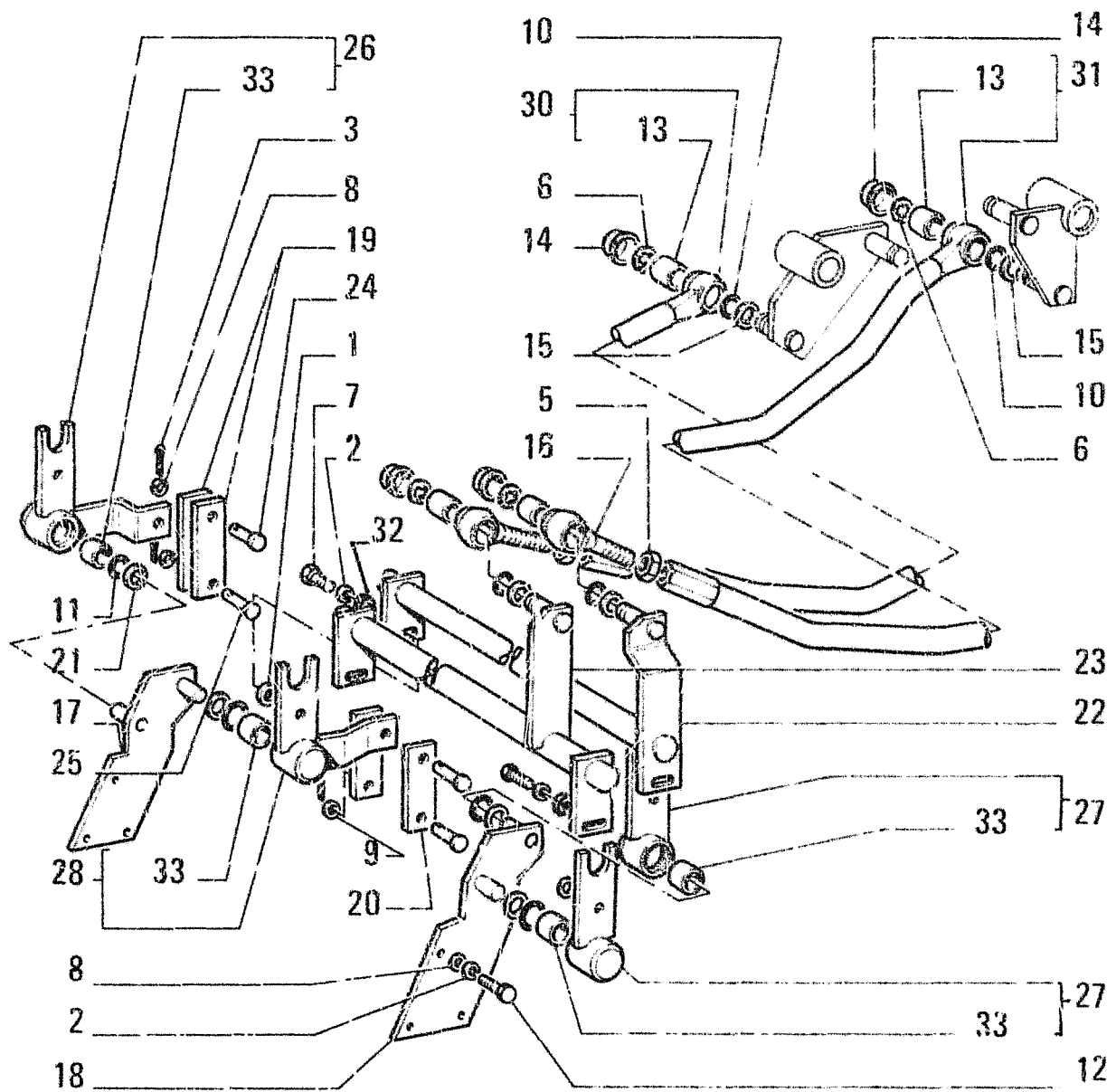

FIATALLIS FD7

B2.10 TAV. 2 PAC.2

ITEM	PART NUMBER	QTY	TRANS CODE	DESCRIPTION	DESCRIZIONE
26	79027933	1	45L	LEVER - RIGHT ASSEMBLY	LEVA - DESTRO COMPLETO
30	79026650	1	142T	TIEROD - LOWER ASSEMBLY	TIRANTE - INFERIORE COMPLETO
31	79026646	1	142T	TIEROD - LOWER ASSEMBLY	TIRANTE - INFERIORE COMPLETO
32	12646821	4	131R	WASHER 10,2x25	ROSETTA 10,2x25
33	79005597	1	95B	BUSHING	BOCCOLA

GEARSHIFT INNER CONTROLS - COMANDI INTERNI CAMBIO DI VELOCITA' - COMMANDES INTERNES DE BOITE DE VITESSES - INNERE GETRIEBESCHALTUNG - BARRAS DEL CAMBIO DE VELOCIDADES

1 B2.10 2
 N.T.R. 205 - 30.09.1991
 604.01.081.06

H15

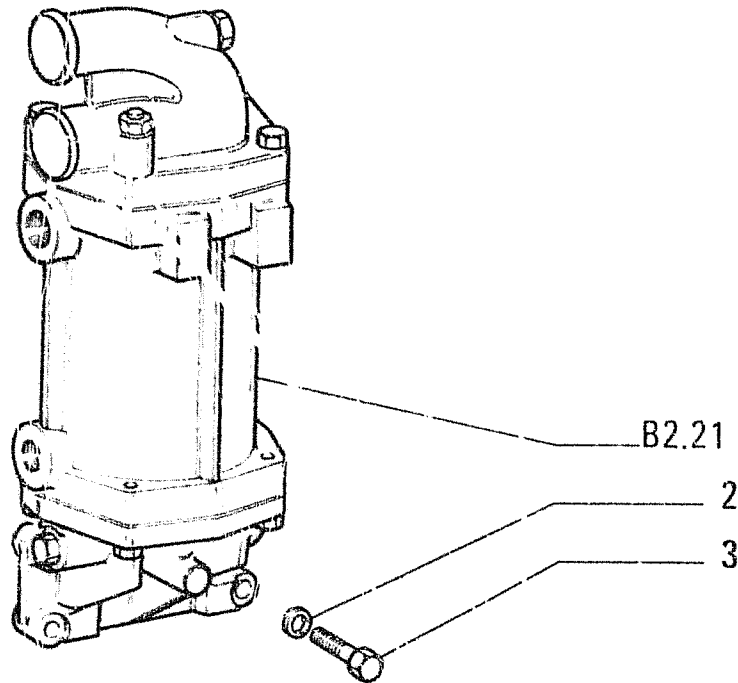

ITEM	PART NUMBER	QTY	TRANS CODE	DESCRIPTION	DESCRIZIONE
2	11198371	4	132R	LOCKWASHER 10,5x20 C1572	ROSETTA DI SICUREZZA 10,5x20 C1572
	11198374	4	131R	WASHER 10,9x20 D1572	ROSETTA 10,9x20 D1572
3	11307021	4	40V	SCREW 10x1,25x40 C1572	VITE 10x1,25x40 C1572
	11307024	4	40V	SCREW D1572	VITE D1572

CONVERTER HEAT EXCHANGER – SCAMBIATORE DI CALORE CONVERTITORE – ECHANGEUR DE TEMPERATURE DU CONVERTISSEUR – WAERMETAUSCHER FUER DREHMOMENTWANDLER – CAMBIADOR DE CALOR DEL CONVERTIDOR

2

B2.18

N.T.R. 205 - 30.09.1991
604.01.081.06

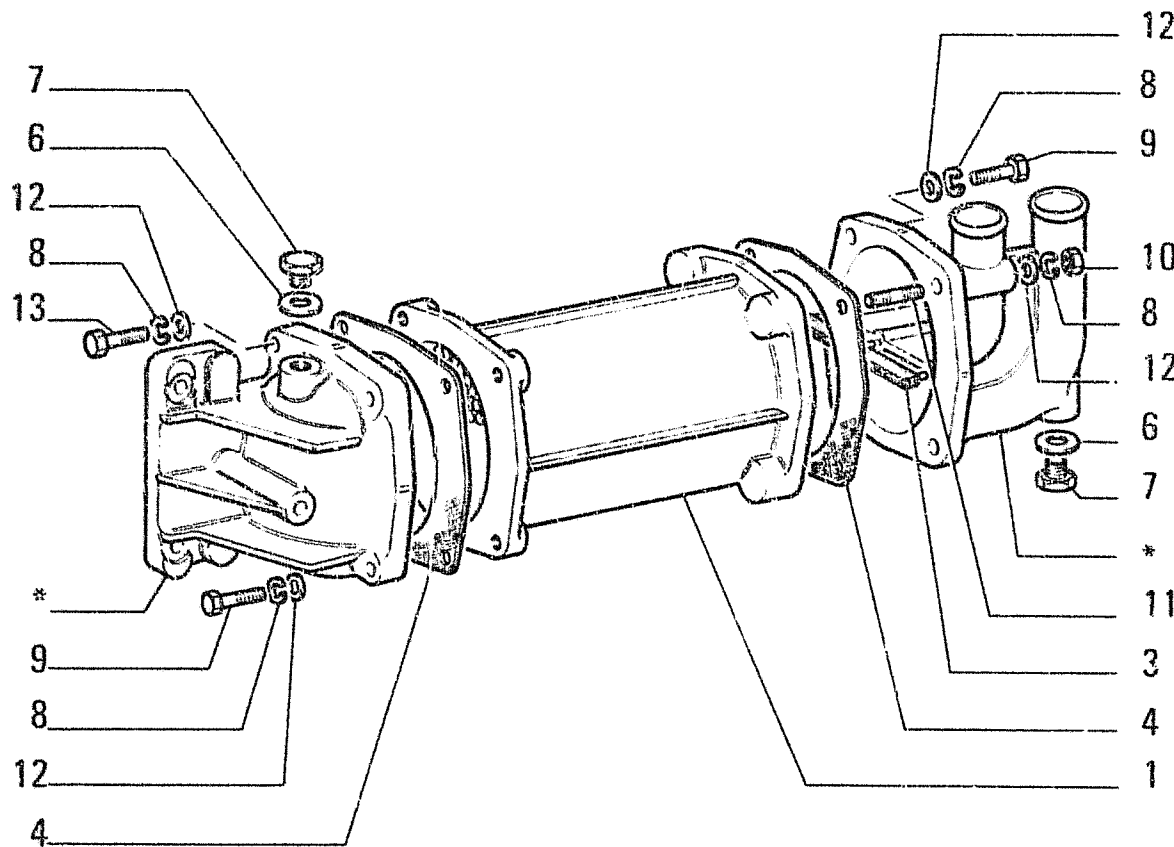

PARTS MARKED * ARE NOT SUPPLIED AS SPARES
 I PARTICOLARI CONTRASSEGNA TI CON * NON
 VENGONO FORNITI DI RICAMBIO

ITEM	PART NUMBER	QTY	TRANS CODE	DESCRIPTION	DESCRIZIONE
1	4727187	1	300C	BODY	CORPO
3	4727848	1	123G	SEAL ASSY	GUARNIZIONE TENUTA FRONTALE
4	4727849	2	123G	SEAL ASSY	GUARNIZIONE TENUTA FRONTALE
6	10257050	4	133R	SEAL 16,2x22	ROSETTA DI TENUTA 16,2x22
7	10300711	4	50T	PLUG 16x1,5x9	TAPPO 16x1,5x9
8	10516870	8	132R	LOCKWASHER 10,2x2,5 C1572	ROSETTA DI SICUREZZA 10,2x2,5 C1572
	10571871	8	131R	WASHER 10,2x2,2 D1572	ROSETTA 10,2x2,2 D1572
9	11307021	5	40V	SCREW 10x1,25x40	VITE 10x1,25x40
10	12164711	1	10D	NUT 10x1,25x8	DADO 10x1,25x8
11	13547521	1	210P	STUD 10x1,25x100	PRIGIONIERO 10x1,25x100
12	13550401	8	131R	WASHER 10,2x20	ROSETTA 10,2x20
13	15970921	2	40V	SCREW 10x1,25x35	VITE 10x1,25x35

HEAT EXCHANGER - SCAMBIATORE DI CALORE - ECHANGEUR DE TEMPERATURE - WAERMETAUSCHER -
 CAMBIADOR DE CALOR

B2.21

N.T.R. 205 - 30.09.1991
 604.01.081.06

H17

DESIGNAZIONE BASE	BASIC DESIGNATION	DESIGNATIONS-BASES	GRUNDBEZEICHNUNGEN	DENOMINACIONES BASE	
107G	GRUPPO ACCENSIONE ELETTRONICO	ELECTRONIC IGNITION SYSTEM	GRUPE D'ALLUMAGE	ELEKTRONISCHE	SISTEMA DE ENCEN-
107G		UNIT	ELECTRONIQUE	ZUENDUNGS-AUS-	DIDO ELECTRONICO
107G				RUESTUNG	
107S	SEMIPULEGGIA	HALF PULLEY	DEMI-POULIE	SCHEIBENHAELFTE	SEMIPOLEA
1070	CILINDRO INCLINAZIONE	TILT CYLINDER	CYLINDRE DE TILT	TILT ZYLINDER	CILINDRO TILT
1071	CILINDRO TILT (HS-L)	TILT CYLINDER (HS-L)	CYLINDRE DE TILT (HS-L)	TILT ZYLINDER (HS-L)	CILINDRO TILT (HS-L)
1072	CILINDRO TILT (HS)	TILT CYLINDER (HS)	CYLINDRE DE TILT (HS)	TILT ZYLINDER (HS)	
1078	COMANDO ATTREZZO POST.	REAR EQUIPMENT CONTROL	COMMANDE D'OUTIL POSTERIEUR	STEUERUNG HECKANBAUGERAETE	MANDO DEL UTIL. POSTERIOR
1080	BORDO	EDGE	PROFILE	PROFIL	PERFIL
108G	GRUPPO DI RINVIO	IDLER UNIT	GROUPE DE RENVOI	ZWISCHENGETRIEBE	REENVIO-REDUCTOR
108M	MOLTIPLICATORE	OVERDRIVE	SURMULTIPLIFICATEUR	DREHMOMENTVERSTAERKER	MULTIPLICADOR
108R	RITARDATORE IDRAULICO	HYDRAULIC RETARDER	RETARDATEUR HY-	HYDRAULISCHE VERZO-	RETARDADOR HIDRAU-
108R			DRAULIQUE	GERUNGSVORRICHTUNG	LICO
108S	SEMISTANTUFFO	HALF PISTON	DEMI-PISTON	KOLBENHAELFTE	SEMIEMBOLO
1082	COMANDO E TUBAZIONI	PIPING AND CONTROL	COMMANDE ET TUYANTERIE	STEUERUNG UND LEITUNGEN	
1083	COMANDO II CASSETTO	2ND SPOOL CONTROL	COMMANDE DU 2ME TIROIR	BETAETIGUNG DES 2 STEUERKREISE	
1084	COMANDO III CASSETTO	3RD SPOOL CONTROL	COMMANDE DU 3ME TIROIR	BETAETIGUNG DES 3 STEUERKREISE	
1087	COMANDO E TUBAZIONI (DAL DEVIATORE)	PIPING AND CONTR(DIVERT VALVE)	COMMANDE ET TUYANTERIE (DEVIAT)	STEUERUNG LEITUNG (VOM UMSCHALT)	MANDO DE LA 3A CARRETES
109B	BORSA PORTACARTE	UTILITY RECESS	VIDE-POCHES	ABLEGEFACH	BOLSA PARA MAPAS
109G	GRUPPO INIEZIONE	INJECTION EQUIPMENT	GROUPE D'INJECTION	EINSPRITZAUS-	GRUPO DE INYECCION
109G				RUESTUNG	
1095	MENSOLE INCERNIERAM	TRUNNIONS	CONSOLES	KUCELBOLZEN	REFUEFLOS
116A	ATTREZZO ANTERIORE	FRONT IMPLEMENT	EQUIPEMENT AVANT	VORNEINRICHTUNG	IMPLEMENTO ANTERIOR
1160	BRACCI E ARTICOLAZIONI	BOOM/LINKAGE	ARTICULATION DE FLECHE	HUBARM UND UMLENKHEBEL	ARTICULACION DEL AIGULON
1161	CILINDRI SOLLEVAMENTO	LIFT CYLINDERS	CYLINDRES LEVAGE	HUBZYLINDER	CILINDRO ALCE
1162	CILINDRI ROTAZIONE BENNA	DUMP CYLINDERS	CYLINDRES DECHARGE	KIPPZYLINDER	CILINDRO DESCARGA
1163	TUBAZIONI CILINDRI SOLLEV	LIFT CYLINDERS PIPING	CONDUITES CYLINDRES LEVAGE	LEITUNGEN FUER HUBZYLINDER	TUBERIA CILINDRO ALCE
1164	TUBAZIONI CILINDRI ROTAZIONE	DUMP CYLINDERS PIPING	TUYAUTERIE CYLINDRES BASCULAGE	LEITUNGEN FUER KIPPZYLINDER	
1165	COMANDI ATTREZZO	EQUIPMENT CONTROLS	COMMANDES D'OUTIL		MANDO DEL UTIL
1168	LIMITAZIONE SOLLEV. BRACCI	LIFTING KICK-OUT		HUBBEGRENZUNG	
110A	AVVOLGIMENTO	WINDING	ENROULEMENT	WICKLUNG	BOBINA
110F	FUSIBILE	FUSE	FUSIBLE	SICHERUNG	FUSIBLE
110G	GRUPPO OTTICO	LENS/REFLECTOR UNIT	GROUPE OPTIQUE	EINSATZ	GRUPO OPTICO
110P	PIASTRINA	PLAQUE	PLAQUETTE	PLAETTCHEN	CHAPITA
110T	TESTA A SNODO	ARTICULATED JOINT	JOINT A ROTULE	GELENKKOPF	ARTICULACION
1103	TUBAZ. CON VALVOLA DEFUSSO	PIPING W/DOWNFLOW VALVE	TUYAUTERIE AVEC SOUPAPE DE DEF		
1107	VALVOLA DISCESA	QUICK RELEASE VALVE	SOUFRAGE DESCENTE RAPIDE	SCHNELLENKVENTIL	
1108	VALVOLA DI BLOCC.	LOCK VALVE	SOUFRAGE DE BLOCAGE	RUECKSCHLAGVENTIL	
111C	CAVO	CABLE	CABLE	ELEKTROKABEL	CABLE
111G	GRUPPO DI REGOLAZIONE	GOVERNOR ASSEMBLY	GROUPE REGULATEUR	REGLERGRUPPE	REGULADOR

DESIGNAZIONE BASE	BASIC DESIGNATION	DESIGNATIONS-BASES	GRUNDBEZEICHNUNGEN	DENOMINACIONES BASE
101G	GRIGLIA	GRID	GRILLE	
1011	FORCELLE	STRUTS	FOURCHES	REJILLA
1012	FORCELLE RINFORZATE	STRUTS H.D	FOURCHES RENFORCEES	
102B	BOMBOLETTA	BOTTLE	BOUTEILLE	
102E	ELEVATORE	ELEVATOR	ELEVATEUR	ENVASE DE GAS
102G	GRU	CRANE	GRUE	ELEVADOR
102P	PIANALE	PLATFORM	PLATEAU	GRUA
1022	LASERPLANE-TRASMETTITORE		LASERPLANE TRANSMETTEUR	PLATAFORMA
1023	LASERPLANE-RICEVITORE		LASERPLANE RECEPTEUR	
103A	ASTUCCIO PORTARULLI	ROLLER CASING	LASERPLANE EMPFAENGER	
103A			HUELSE	CARTER PORTARRO- DILLOS
103E	ESPULSORE	EJECTOR		
103M	MOLLA A DIAFRAMMA	DISC SPRING	RONDELLE-RESSORT	
103M			FEDERSCHEIBE	DIAFRAGMA DE MUE- LLE
103P	PIANTONE	STEERING COLUMN	COLONNE DIRECTION	COLUMNA DIRECCION
103S	SEMICUSCINETTO	HALF BEARING	DEMI-ROULEMENT	SEMIRODAMIENTO
1030	CILINDRI ANGOLAZIONE	ANGLE CYLINDERS	CYLINDRES AD	
104A	ATTACCO PER ATTREZZI	EQUIPMENT MOUNTING	ATTELAGE DES OU- TILS	ENGANCHE DE LOS UTILES
104A			JEU DE COMMANDE DE DISTRIBUTION	JUEGO DE PINONES DE LA DISTRIBUCION
104G	GRUPPO COMANDO DI DISTRIBUZIONE	CAMSHAFT DRIVE SET	DEMI-DISQUE	SEMIDISCO
104G			BRAS ET TIRANTS (HSU-HS)	BRAZOS Y TIRANTES (HSU-HS)
104S	SEMIDISCO	HALF DISC	BRAS ET TIRANTS (HS-L)	BRAZOS Y TIRANTES (HS-L)
104D	BRACCI E TIRANTI (HSU-HS)	PUSHBEAMS AND STRUTS (HSU-HS)	BRAS ET TIRANTS (HS)	BRAZOS Y TIRANTES (HS)
1041	BRACCI E TIRANTI (HS-L)	PUSHBEAMS AND STRUTS (HS-L)	BRAS ET TIRANTS (HS)	BRAZOS Y TIRANTES (HS)
1042	BRACCI E TIRANTI (HS)	PUSHBEAMS AND STRUTS (HS)	BRAS ET TIRANTS (TILT-PITCH)	BRAZOS Y TIRANTES (TILT-PITCH)
1043	BRACCI E TIRANTI (TILT-PITCH)	PUSHBEAMS & STRUTS(TILT-PITCH)	AVVERTISSEUR	BOCINA
105A	AVVISATORE ACUSTICO	HORN	CABLE	CABLE
105F	FUNE	CABLE	GROUPE DE ROTATION	GRUPO DE ROTACION
105G	GRUPPO DI ROTAZIONE	ROTATION UNIT	AGRAFE	SUJETADOR
105M	MOLLETTA	SPRING FASTENER	PLAQUE	PLACA
105P	PIASTRA	PLATE	RECHAUFFEUR	CALENTADOR
105R	RISCALDATORE	HEATER	DEMI-JOINT	SEMIACOPLAMIENTO
105S	SEMIGIUNTO	HALF COUPLING	PROFILE	PERFIL
106B	BORDINO	MOLDING	GROUPE AMORTISSEUR	GRUPO AMORTIGUADOR
106G	GRUPPO AMMORTIZZANTE	SHOCK ABSORBING UNIT	RECHAUFFEUR ELEC- TRIQUE	RESISTENCIA DE CALDEO
106R	RISCALDATORE ELETTRICO	HEATING ELEMENT	DEMI-JOINT	SEMIGUARNICION
106R			CYLINDRE DE TILT(ALL-HYDRAULIC)	
106S	SEMIGUARNIZIONE	HALF GASKET	CAOUTCHOUC	
1065	CILINDRO TILT (ALL-HYDRAULIC)	TILT CYLINDER (ALL-HYDRAULIC)		
107B	BORDO DI GOMMA	WEATHERSTRIP		GOMA

DESIGNAZIONE BASE	BASIC DESIGNATION	DESIGNATIONS-BASES	GRUNDBEZEICHNUNGEN	DENOMINACIONES BASE
EL	ELIMINATO	DELETED	ELIMINE	ELIMINADO
ERR	ERRATA	WRONG	ERRATA	DONDE DICE
EST	ESTERNO	OUTER	EXTERIOR	EXTERIOR
FA00	AGRICOLA A CINGOLI	AGRICULTURAL CRAWLER	TRACT.AGRICOLE SUR CHENILLES	TRACTOR AGR.COLO SOBRE ORUGAS
FB00	TERNA	BACKHOE LOADER	CHARGEUSE-PELLEUSE	TERNA SOBRE RUEDAS
FD0V	APRIPISTA CINGOLI LGP	CRAWLER DOZER-LGP	BOUTEUR SUR CHENILLES LGP	ABRETROCHAS LGP
FD00	APRIPISTA CINGOLI	CRAWLER DOZER	BOUTEUR SUR CHENILLES	ABRETROCHAS
FE0P	ESCAVATORE A CINGOLI LC	CRAWLER EXCAVATOR-LC	PELLE SUR CHENILLES LC	EXCAVADORA SOBRE ORUGAS LC
FE0R	ESCAVATORE A CINGOLI HD	CRAWLER EXCAVATOR-HD	PELLE SUR CHENILLES HD	EXCAVADORA SOBRE ORUGAS HD
FE0W	ESCAVATORE A RUOTE	WHEEL EXCAVATOR	PELLE SUR PNEUS	EXCAVADORA SOBRE RUEDAS
FE00	ESCAVATORE A CINGOLI	CRAWLER EXCAVATOR	PELLE SUR CHENILLES	EXCAVADORA SOBRE ORUGAS
FG00	MOTOLIVELLATRICE	MOTOR-GRADER	NIVELEUSE SUR PNEUS	MOTONIVELADORA
FLOP	CARICATORE A CINGOLI LGP	CRAWLER LOADER-LGP	CHARGEUSE SUR CHENILLES LGP	CARGADORA SOBRE ORUGAS LGP
FLO0	CARICATORE A CINGOLI	CRAWLER LOADER	CHARGEUSE SUR CHENILLES	CARGADORA SOBRE ORUGAS
FP00	POSATUBI	PIPE-LAYER	POSEUR DE TUBES	TIENDETUBOS
FR0C	COMPATTATORE A RUOTE	WHEEL COMPACTOR		
FR00	CARICATORE ART RUOTE	WHEEL LOADER	CHARGEUSE SUR PNEUS	CARGADORA SOBRE RUEDAS
FS00	MOTORUSPA	MOTOR-SCRAPER	DECAPEUSE SUR PNEUS	MOTOTRAILLA
G214	TRASLAZIONE RETROESCAVATORE	BACKHOE TRASLATION		
INF	INFERIORE	LOWER	INFERIEUR	INFERIOR
INT	INTERNO	INNER	INTERIEUR	INTERIOR
LAT	LATERALE	SIDE	LATERAL	LATERAL
POST	POSTERIORE	REAR	ARRIERE	POSTERIOR
SALD	DA SALDARE	TO BE WELDED	A SOLDER	SOLDAR
SEM	SEMILAVORATO	SEMIFINISHED	MI-OUVRE	SEMILABORADO
SN	SINISTRO	LEFT	GAUCHE	IZQUIERDO
SP	SPESSORE	THICKNESS	EPAISSEUR	GRUESO
SUP	SUPERIORE	UPPER	SUPERIOR	SUPERIOR
VED	VEDERE SGR	SEE SGR	VOIR SGR	VEASE SGR
10G3	ARRESTO MOTORE	ENGINE STOP	ARRET DU MOTEUR	PARO DEL MOTOR
100B	BICCOLA DI GOMMA	RUBBER BUSH	BAGUE CAOUTCHOUC	COJINETE DE CAUCHO
100C	CAYALLOTTO	RETAINER	ARRETOIR	SUJETADOR
100G	GRIGLIA DEL RADIATORE	RADIATOR GRILLE	GRILLE DE RADIA- TEUR	CORAZA DEL RADIA- DOR
100M	MOLLA	SPRING	RESSORT	MUELLE
100R	RIPOSTIGLIO CRUSCOTTO	RECESS	BOITE A CANTS	GUANTERA
100S	SEMICONO	LOCK CONE	DEMI-CONE	CHAVETA CONICA
1003	ARCONI (ALL-HYDRAULIC)	C-FRAME (ALL-HYDRAULIC)	ETRIER (ALL-HYDRAULIC)	ARCON (ALL-HYDRAULIC)
101A	ASTUCCIO	CASING	ETUI	ESTUCHE
101E	ELETTROLITO	ELECTROLYTE	ELECTROLYTE	ELECTROLYTE

B

MECHANICAL TRANSMISSION • CLUTCH • TRANSMISSION • TRANSMISSION SHAFT • AXLES
TRASMISSIONE MECCANICA • FRIZIONE • CAMBIO • ALBERO DI TRASMISSIONE • PONTI
TRANSMISSION MECANIQUE • EMBRAYAGE • BOITE DE VITESSES • ARBRE DE TRANSMISSION • PONTS
MECHANISCHE KRAFTÜBERTRAGUNG • KUPPLUNG • GETRIEBE • GELENKWELLE • ACHSEN
TRANSMISION MECANICA • EMBRAGUE • CAMBIO • ARBOL DE TRANSMISSION • PUENTES

F-1

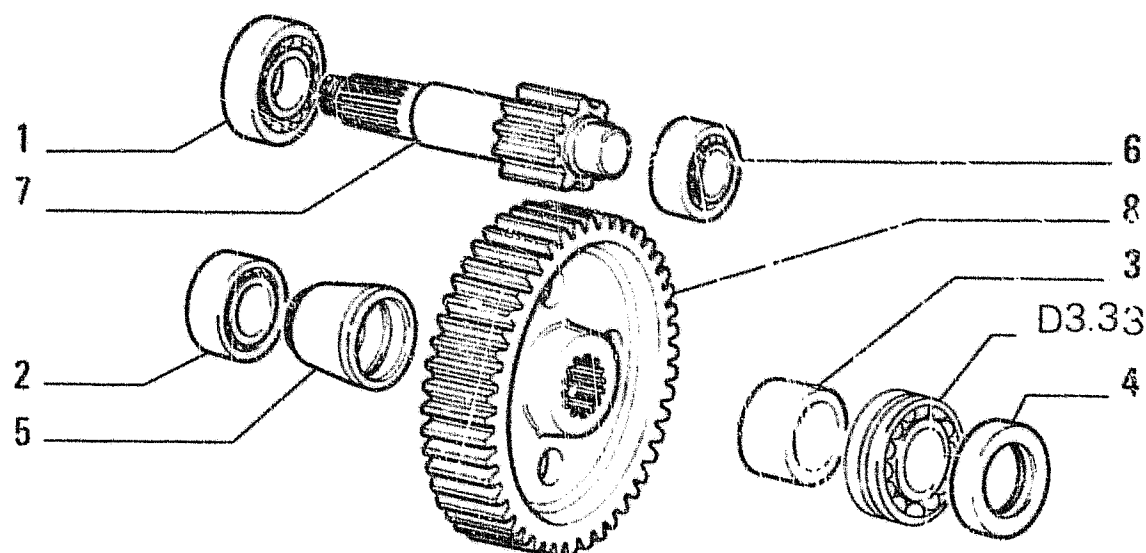

ITEM	PART NUMBER	QTY	TRANS CODE	DESCRIPTION	DESCRIZIONE
1	20147000	2	341C	BEARING - INNER 55x120	CUSCINETTO - INTERNO 55x120
2	26797000	2	341C	BEARING - INNER 50x110	CUSCINETTO - INTERNO 50x110
3	79012997	2	75D	SPACER - OUTER	DISTANZIALE - ESTERNO
4	79012999	2	45A	RING C1579	ANELLO C1579
	79058654	2	45A	RING D1579	ANELLO D1579
5	79024824	2	75D	SPACER - INNER	DISTANZIALE - INTERNO
6	79026476	2	341C	BEARING - OUTER	CUSCINETTO - ESTERNO
7	79031654	2	50I	GEAR	INGRANAGGIO
8	79031655	2	50I	GEAR	INGRANAGGIO

REAR SIDE FINAL DRIVE GEARS - RUOTISMI RIDUTTORI LATERALI POSTERIORI - ENGRANAJES DE REDUCTORES LATERALES POSTERIORES

3

B4.12

N.T.R. 158 - 13.03.1987
604.01.081.03

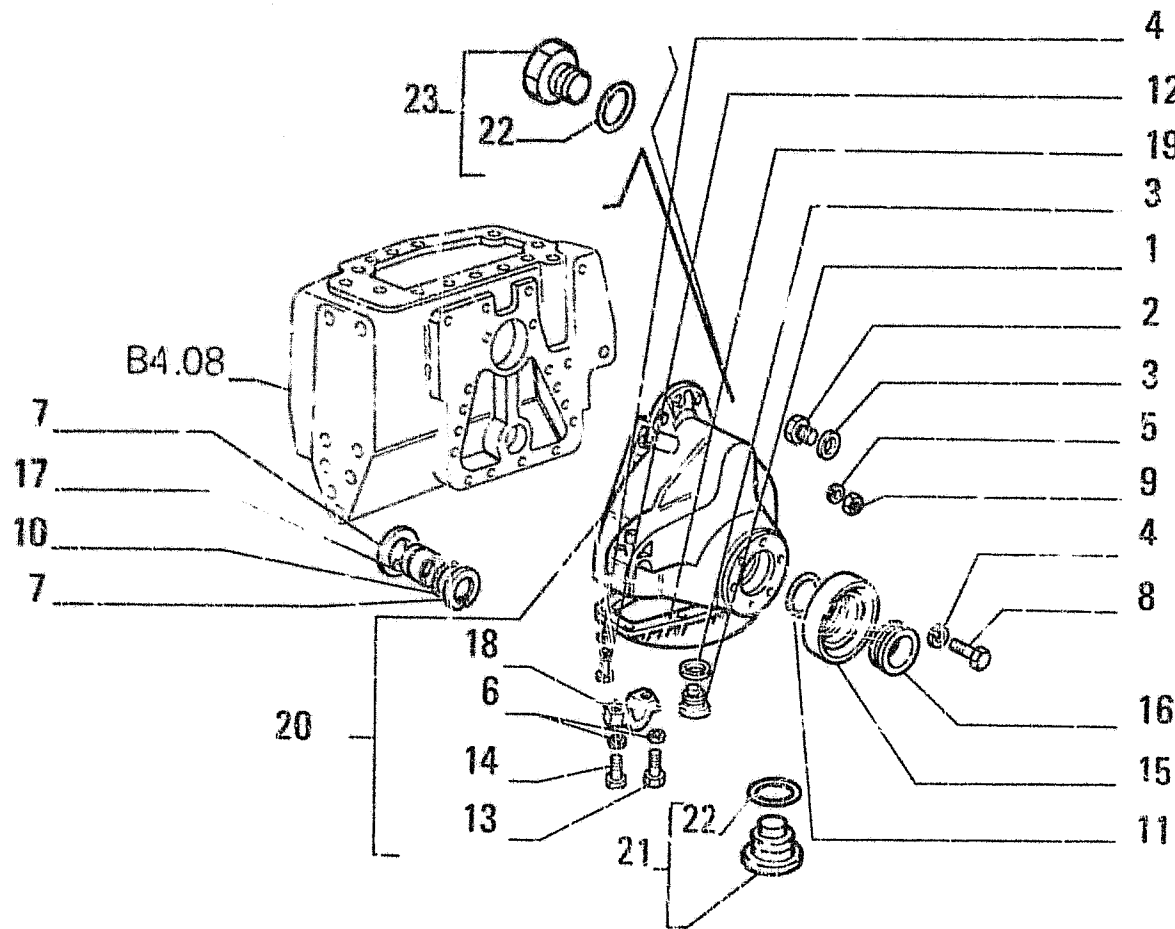

ITEM	PART NUMBER	QTY	TRANS CODE	DESCRIPTION	DESCRIZIONE
	23	10119140			
			D2836		
				D2836	

REAR SIDE FINAL DRIVE CASES - SCATOLE RIDUTTORI LATERALI POSTERIORI - CARTERS DE REDU- 3
 CTEURS LATERAUX AR - GEHAEUSE DER HINTEREN ENDANTRIEBE - CAJAS DE REDUCTORES LATERA-
 LES POSTERIORES -

B4.11
 N.T.R. 191 - 20.02.1990
 604.01.081.04

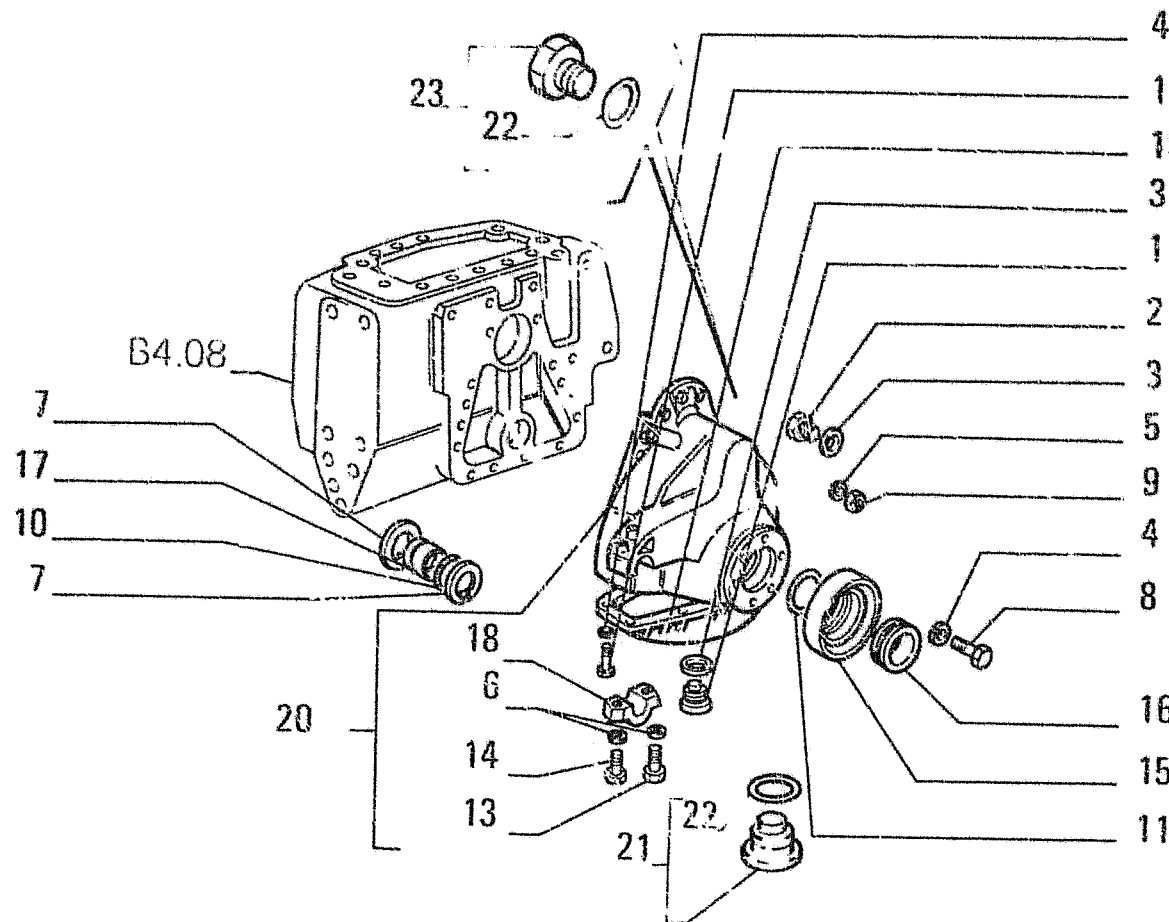

ITEM	PART NUMBER	QTY	TRANS CODE	DESCRIPTION	DESCRIZIONE
1	739124	2	57T	MAGNETIC PLUG C2836	TAPPO MAGNETICO C2836
2	10273011	2	50T	PLUG 40x1,5x13 C2836	TAPPO 40x1,5x13 C2836
3	10297080	4	133R	SEAL 40,3x48 C2836	ROSETTA DI TENUTA 40,3x48 C2836
4	10516871	32	132R	LOCKWASHER 10x2,5	ROSETTA DI SICUREZZA 10x2,5
5	10517171	34	132R	LOCKWASHER 14,2x3,5	ROSETTA DI SICUREZZA 14,2x3,5
6	10517371	4	132R	LOCKWASHER 18,2x4,2	ROSETTA DI SICUREZZA 18,2x4,2
7	11075476	4	45A	RING 117x4	ANELLO 117x4
8	11343831	12	40V	SCREW 10x1,25x50	VITE 10x1,25x50
9	12164021	34	10D	NUT 14x1,5x11	DADO 14x1,5x11
10	14466090	2	158G	O-RING 3,53x101,19	GUARNIZIONE O-R 3,53x101,19
11	14467680	2	158G	O-RING 3,53x152	GUARNIZIONE O-R 3,53x152
12	15970931	20	40V	SCREW 10x1,25x35	VITE 10x1,25x35
13	15985637	2	40V	SCREW 18x1,5x120	VITE 18x1,5x120
14	15986837	2	40V	SCREW 18x1,5x180	VITE 18x1,5x180
15	79012989	2	300S	SUPPORT	SUPPORTO
16	78012991	2	158G	O-RING	GUARNIZIONE O-R
17	79012992	2	265C	COVER	COPERCHIO
18	79023991	2	64C	CAP	CAPPELLO
19	79030120	2	265C	COVER	COPERCHIO
20	79030122	1	35S	CASE - ASSEMBLY LEFT	SCATOLA - COMPLETO SINISTRO
	79030124	1	35S	CASE - ASSEMBLY RIGHT	SCATOLA - COMPLETO DESTRO
21	10231240	2	57T	MAGNETIC PLUG - ASSEMBLY 42x2x16 D2836	TAPPO MAGNETICO - COMPLETO 42x2x16 D2836
22	14438385	4	158G	O-RING 3x39 D2836	GUARNIZIONE O-R 3x39 D2836
23	10119140	2	50T	PLUG - ASSEMBLY 42x2x16	TAPPO - COMPLETO 42x2x16

REAR SIDE FINAL DRIVE CASES - SCATOLE RIDUTTORI LATERALI POSTERIORI - CARTERS DE REDUCTEURS LATERAUX AR -- GEHAEUSE DER HINTEREN ENDANTRIEBE - CAJAS DE REDUCTORES LATERALES POSTERIORES

3

B4 11

N.T.R. 191 - 20.02.1990

604.01.081.04

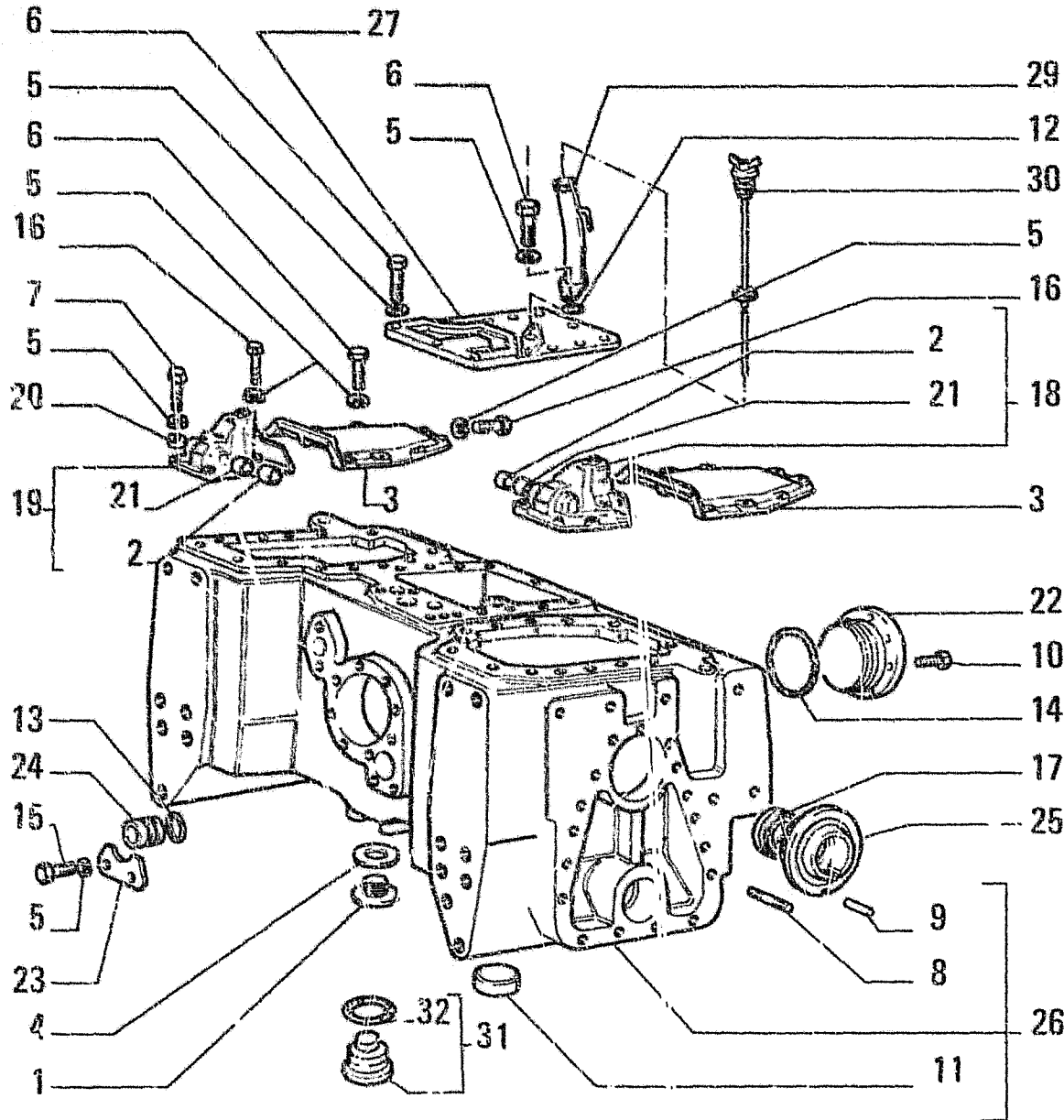

ITEM	PART NUMBER	QTY	TRANS CODE	DESCRIPTION	DESCRIZIONE
26	79044942	1	35S	CASE - ASSEMBLY D1519	SCATOLA - COMPLETO D1519
		1	35S	CASE - ASSEMBLY C1520	SCATOLA - COMPLETO C1520
	79050503	1	35S	CASE - ASSEMBLY D1520	SCATOLA - COMPLETO D1520
27	79023989	1	265C	COVER CENTR.	COPERCHIO CENTR.
29	79040490	1	193T	TUBE	TUBO RIGIDO
30	79040491	1	53T	DIPSTICK W/CAP	TAPPO DI INTRODUZIONE OLIO CON ASTA LIVELLO
31	10231240	1	57T	MAGNETIC PLUG - ASSEMBLY 42x2x16 D2836	TAPPO MAGNETICO - COMPLETO 42x2x16 D2836
32	14438385	1	158G	O-RING 3x39 D2836	GUARNIZIONE O-R 3x39 D2836

REAR DRIVE BODY CASINGS AND COVERS - CORPO TRASMISSIONE POSTERIORE, SCATOLE E COPERCHI -
 CHASSIS-BERCEAU AR, CARTERS ET COUVEROLES - HINTERACHSUEBERTRAGUNG, GEHAUSE UND DECKEL -
 CUERPO DE TRANSMISION POSTERIOR, CAJAS Y TAPAS

B/4.08
 N.T.R. 191 - 26.02.1990
 604.01.081.04

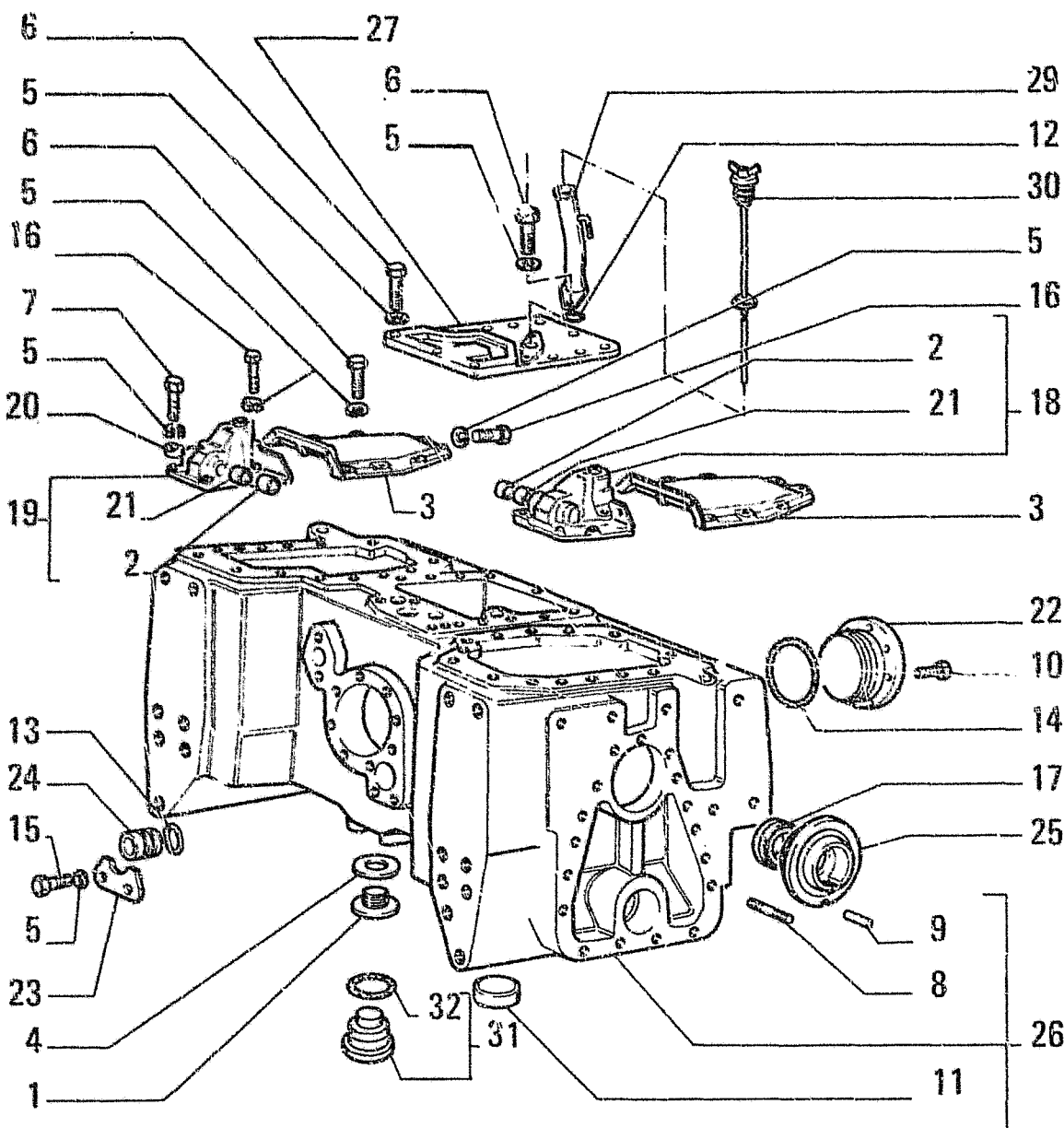

FIATALLIS FD7

B4.08 TAV. 1 PAG.1

ITEM	PART NUMBER	QTY	TRANS CODE	DESCRIPTION	DESCRIZIONE
1	739124	1	57I	MAGNETIC PLUG C2836	TAPPO MAGNETICO C2836
2	4967729	2	95B	BUSHING - INNER	BOCCOLA - INTERNO
3	4983464	2	265C	COVER	COPERCHIO
4	10297080	1	133R	SEAL 40,3x48 C2836	ROSETTA DI TENUTA 40,3x48 C2836
5	10516871	43	132R	LOCKWASHER 10x2,5	ROSETTA DI SICUREZZA 10x2,5
6	11306931	29	40V	SCREW 10x1,25x30	VITE 10x1,25x30
7	11307031	4	40V	SCREW 10x1,25x40	VITE 10x1,25x40
8	13555530	34	210V	STUD 14x1,5x63	PRIGIONIERO 14x1,5x63
9	14167770	2	200S	PIN 6,4x16	SPINA 6,4x16
10	14233630	4	40V	SCREW 10x1,25x30	VITE 10x1,25x30
11	14329701	4	50T	PLUG 60x18 C1520	TAPPO 60x18 C1520
12	14458780	1	158G	O-RING 2,62x39,34	GUARNIZIONE O-R 2,62x39,34
13	14464280	1	158G	O-RING 3,53x44,04	GUARNIZIONE O-R 3,53x44,04
14	14467180	1	158G	O-RING 3,53x136,1	GUARNIZIONE O-R 3,53x136,1
15	15970531	2	40V	SCREW 10x1,25x20	VITE 10x1,25x20
16	15970931	8	40V	SCREW 10x1,25x35	VITE 10x1,25x35
17	40000150	2	158G	O-RING 90x120	GUARNIZIONE O-R 90x120
18	76000589	1	265C	COVER - LEFT ASSEMBLY	COPERCHIO - SINISTRO COMPLETO
19	76000591	1	265C	COVER - RIGHT ASSEMBLY	COPERCHIO - DESTRO COMPLETO
20	79005244	4	131R	WASHER	ROSETTA
21	79007711	2	95B	BUSHING - OUTER	BOCCOLA - ESTERNO
22	79012295	1	265C	COVER - REAR	COPERCHIO - POSTERIORE
23	79012304	1	110P	PLAQUE	PIASTRINA
24	79012305	1	50T	PLUG	TAPPO
25	79013328	2	35S	CASE	SCATOLA
26	79023988	1	35S	CASE - ASSEMBLY C1519	SCATOLA - COMPLETO C1519

REAR DRIVE BODY CASINGS AND COVERS - CORPO TRASMISSIONE POSTERIORE, SCATOLE E COPERCHI -
 CHASSIS-BERCEAU AR. CARTERS ET COUVEROLES - HINTERACHSUEBERTRAGUNG, GEHAUSE UND DECKEL -
 CUERPO DE TRANSMISION POSTERIOR, CAJAS Y TAPAS

B4.08

N.T.R. 191 - 20.02.1990

604.01.081.04

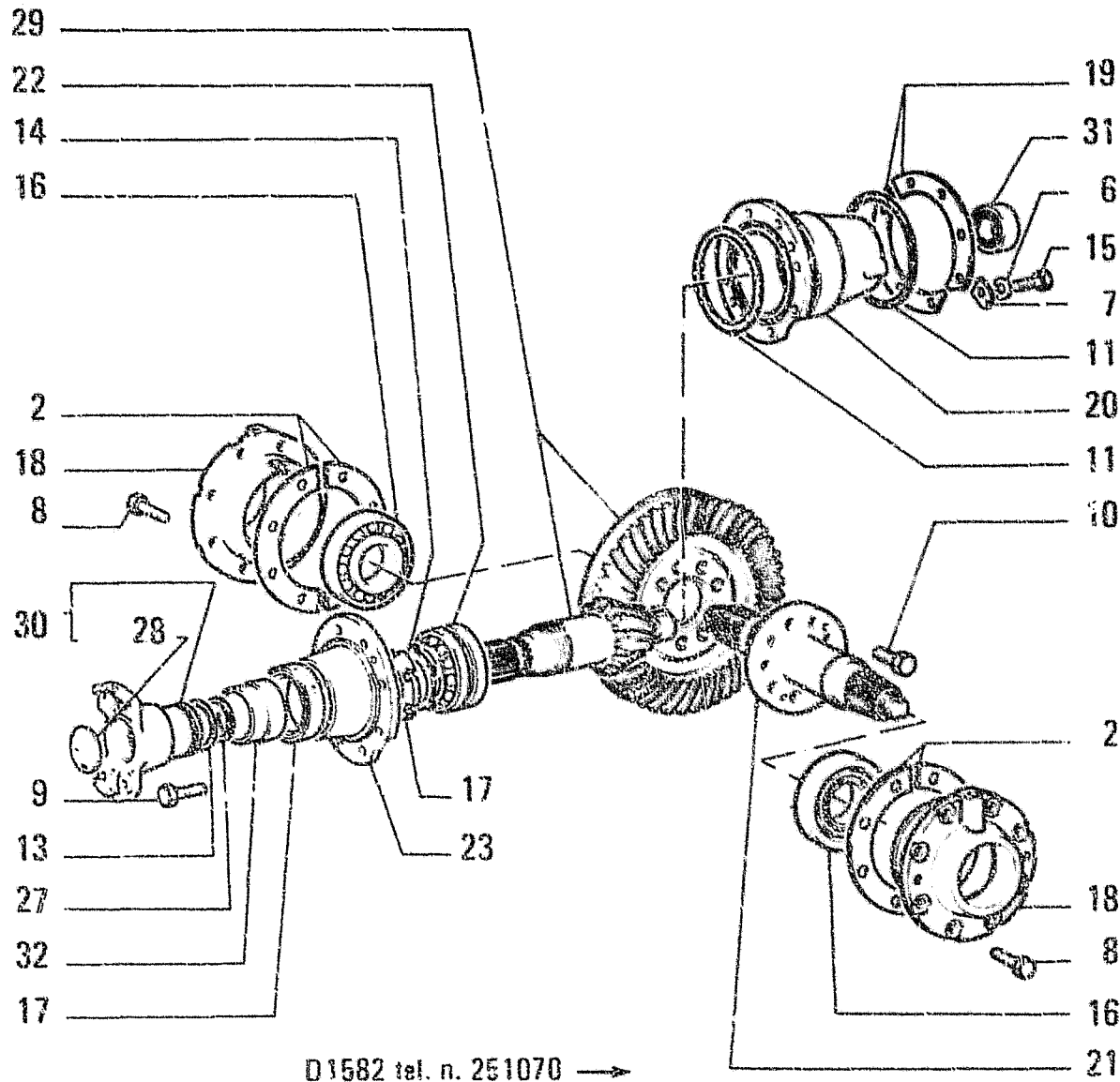

ITEM	PART NUMBER	QTY	TRANS CODE	DESCRIPTION	DESCRIZIONE
29	79058650	1	285C	BEVEL GEAR SET	COPPIA CONICA
30	79058651	1	30M	SLEEVE - ASSEMBLY	MANICOTTO - COMPLETO
31	79037536	1	341C	BEARING	CUSCINETTO
32	79058649	1	45A	RING	ANELLO

CENTRAL DRIVE GEARS - RUOTISM! RIDUZIONE CENTRALE - ENGRENAGES DE REDUCTION CENTRALE
 ZAHNRAEDER F.MITTELACHSUNTERSETZUNG - ENGRANAJES DE REDUCCION CENTRAL

B4.04/A

N.T.R. 158 - 13.03.1987
 604.01.081.03

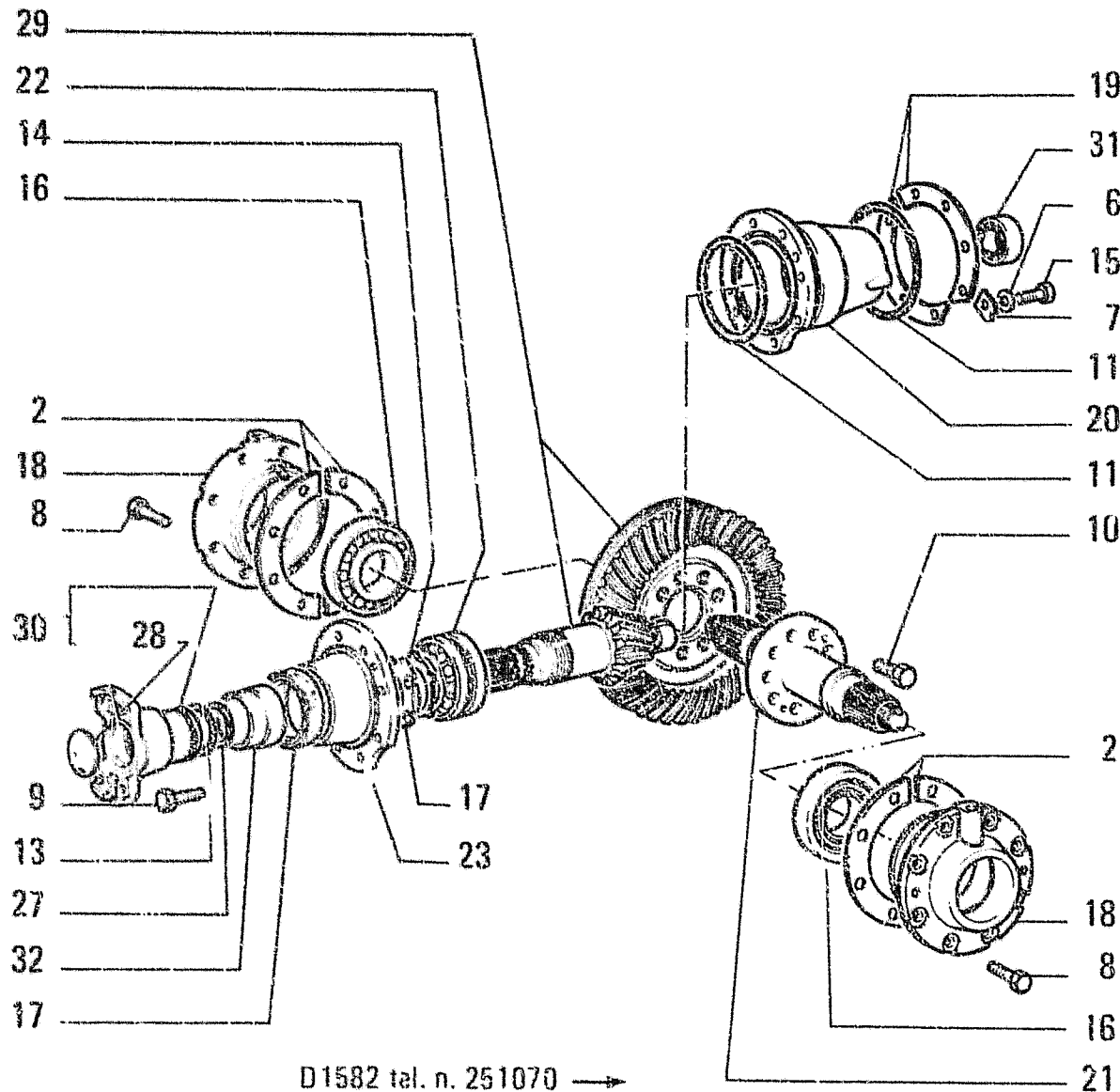

ITEM	PART NUMBER	QTY	TRANS CODE	DESCRIPTION	DESCRIZIONE
2	4967707		198S	SHIM 0,15	SPESSORE 0,15
	4967708		198S	SHIM 0,3	SPESSORE 0,3
	4967709		198S	SHIM 0,5	SPESSORE 0,5
	4967710		198S	SHIM 0,7	SPESSORE 0,7
6	10516671	1	170R	LOCKWASHER 8,1x2,2	ROSETTA EL. 8 1x2,2
7	12647001	1	113P	LOCKPLATE 8,15x25	PIASTRINA DI SICUREZZA 8,15x25
8	14233630	16	40V	SCREW 10x1,25x30	VITE 10x1,25x30
9	14254930	8	40V	SCREW 14x1,5x55	VITE 14x1,5x55
10	14271530	9	40V	SCREW 18x1,5x40	VITE 18x1,5x40
11	14486880	2	158G	O-RING 3,53x126,59	GUARNIZIONE O-R 3,53x126,59
12	10212210	1	50G	RING NUT 60x1,5x80	GHIERA 60x1,5x80
13	14471480	1	158G	O-RING 5,33x56,52	GUARNIZIONE O-R 5,33x56,52
14	12948810	1	131R	WASHER 60x72	ROSETTA 60x72
15	16043231	1	40V	SCREW 8x1,25x16	VITE 8x1,25x16
16	26800390	2	341C	BEARING 55x120	CUSCINETTO 55x120
17	40001670	1	157G	LIP SEAL 80x110	GUARNIZIONE ALBERO ROTANTE 80x110
18	79012293	2	300S	SUPPORT	SUPPORTO
19	79012300		198S	SHIM 1	SPESSORE 1
	79012301		198S	SHIM 0,5	SPESSORE 0,5
	79012302		198S	SHIM 0,2	SPESSORE 0,2
20	79013289	1	300S	SUPPORT	SUPPORTO
21	79013334	1	16A	SHAFT	ALBERO
22	79013339	1	341C	BEARING	CUSCINETTO
23	79058647	1	265C	COVER	COPERCHIO
27	11069376	1	187A	SNAP RING 45,8x2	ANELLO ELASTICO 45,8x2
28	10160500	1	50T	PLUG 55x2	TAPPO 55x2

CENTRAL DRIVE GEARS – RUOTISMI RIDUZIONE CENTRALE – ENGRNAGES DE REDUCTION CENTRALE
 ZAHNRAEDER F. MITTELACHSUNTERSETZUNG – ENGRANAJES DE REDUCCION CENTRAL

B4.04/A

N.T.R. 158 - 13.03.1987
 604.01.081.03

C1582 → tel. n. 251069

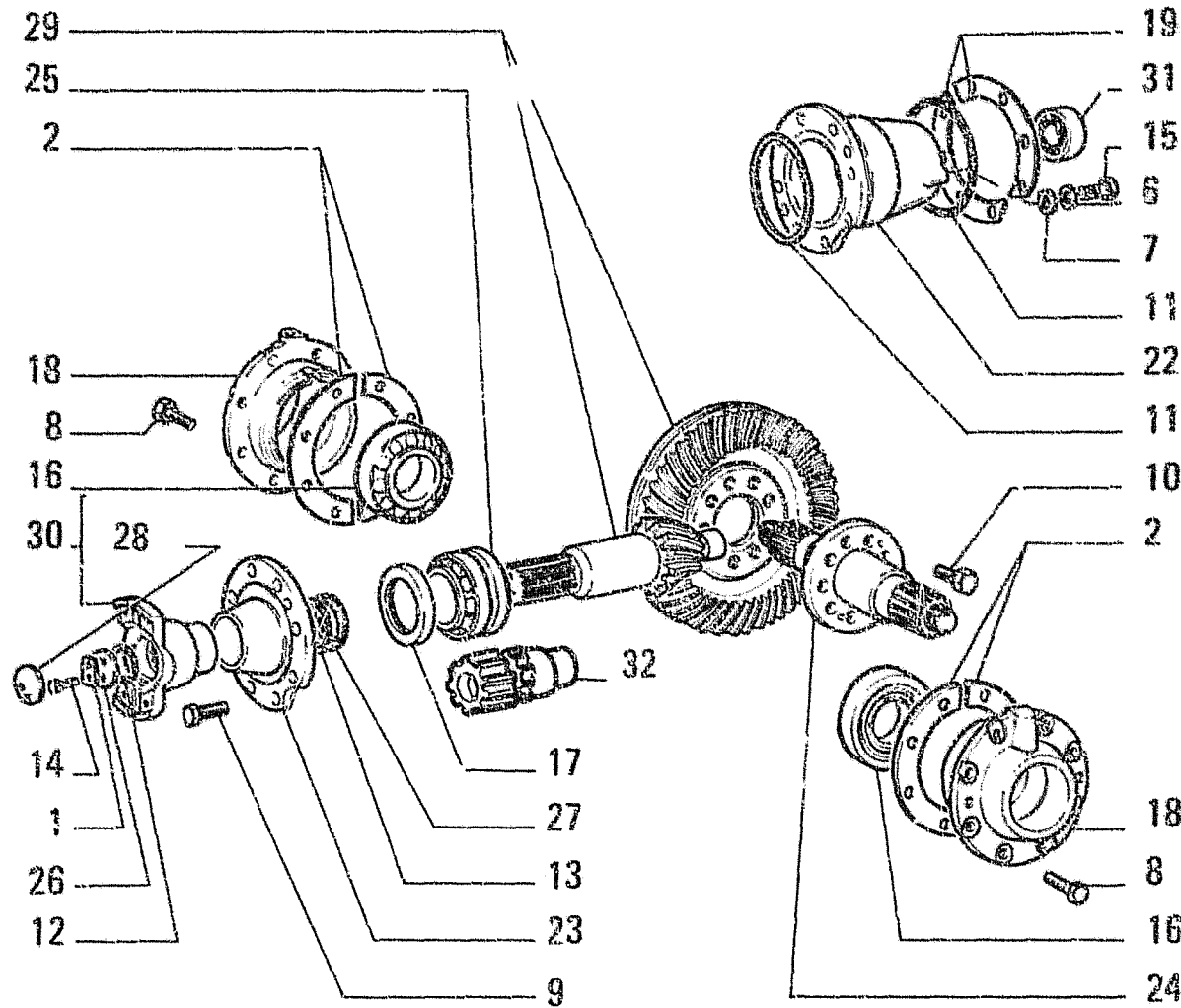

ITEM	PART NUMBER	QTY	TRANS CODE	DESCRIPTION	DESCRIZIONE
26	79013340	1	131R	WASHER C1558	ROSETTA C1558
	79061879	1	131R	WASHER D1558	ROSETTA D1558
27	79013342	2	45A	RING	ANELLO
28	79020868	1	58T	PLUG	TAPPO
29	79026346	1	205C	BEVEL GEAR SET	COPPIA CONICA
30	79028394	1	30M	SLEEVE - ASSEMBLY	MANICOTTO - COMPLETO
31	79037536	1	341C	BEARING	CUSCINETTO
32	79013338	1	30M	SLEEVE	MANICOTTO

CENTRAL DRIVE GEARS - RUOTISMI RIDUZIONE CENTRALE - ENGRENAJES DE REDUCCION CENTRAL 4
 ZAHNRAEDER F.MITTELACHSUNTERSETZUNG - ENGRANAJES DE REDUCCION CENTRAL

B4.04

N.T.R. 158 - 13.03.1987
 604.01.081.03

C1582 → tel. n. 251069

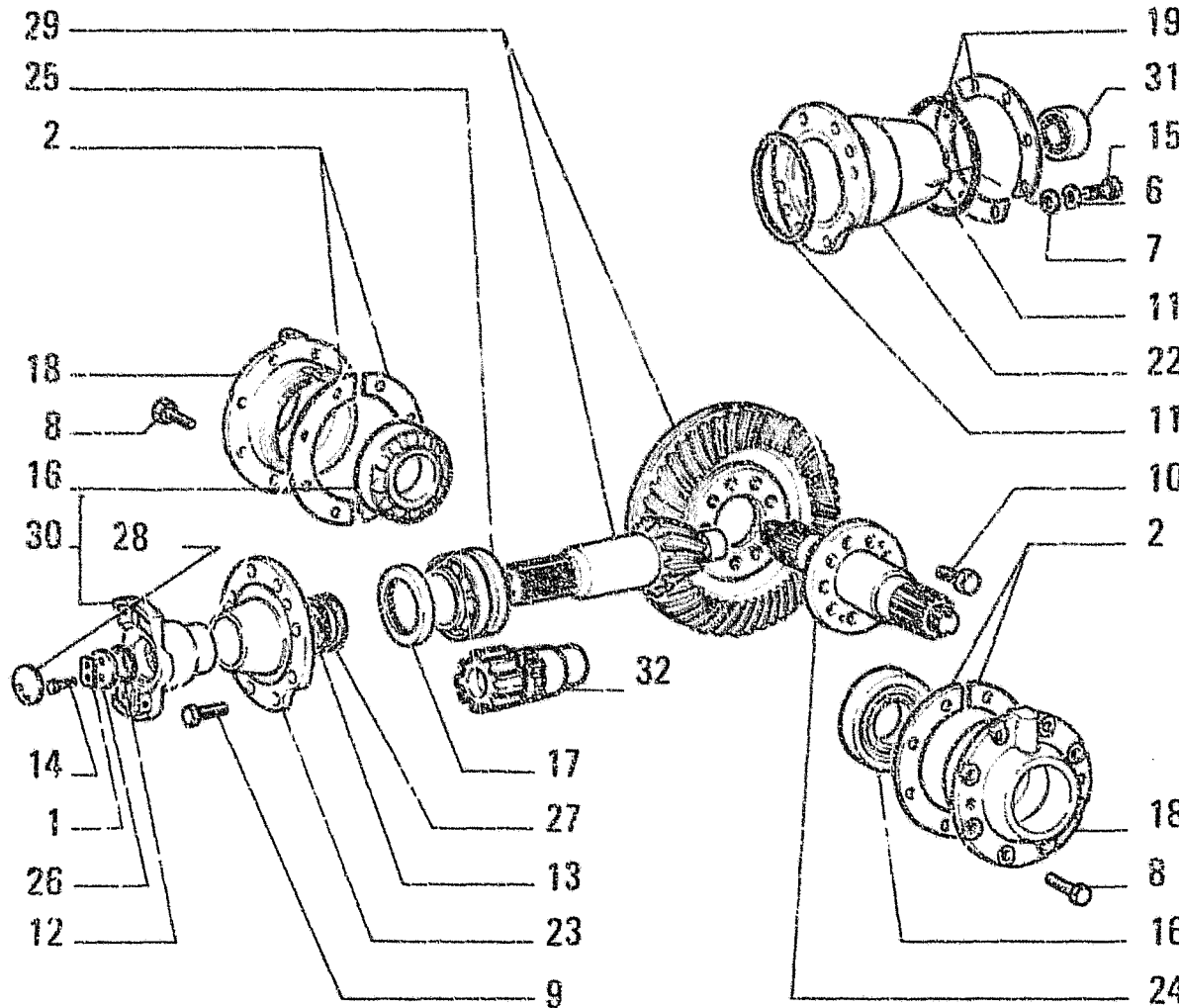

ITEM	PART NUMBER	QTY	TRANS CODE	DESCRIPTION	DESCRIZIONE
1	592915	1	113P	LOCKPLATE C1558	PIASTRINA DI SICUREZZA C1558
2	4967707		198S	SHIM 0,15	SPESSORE 0,15
	4967708		198S	SHIM 0,3	SPESSORE 0,3
	4967709		196S	SHIM 0,5	SPESSORE 0,5
	4967710		198S	SHIM 0,7	SPESSORE 0,7
6	10516671	1	132R	LOCKWASHER 8,1x2,2	ROSETTA DI SICUREZZA 8,1x2,2
7	12647001	1	131R	WASHER 8,15x25	ROSETTA 8,15x25
8	14233630	10	40V	SCREW 10x1,25x30	VITE 10x1,25x30
9	14254930	8	40V	SCREW 14x1,5x55	VITE 14x1,5x55
10	14271530	9	40V	SCREW 18x1,5x40	VITE 18x1,5x40
11	14466880	2	158G	O-RING 3,53x126,59	GUARNIZIONE O-R 3,53x126,59
12	14470980	1	158G	O-RING 5,33x40,64	GUARNIZIONE O-R 5,33x40,64
13	14472080	1	158G	O-RING 5,33x75,56	GUARNIZIONE O-R 5,33x75,56
14	14233430	2	40V	SCREW 10x1,25x25 D1558	VITE 10x1,25x25 D1558
	15970731	2	40V	SCREW 10x1,25x25 C1558	VITE 10x1,25x25 C1558
15	16043231	1	40V	SCREW 8x1,25x16	VITE 8x1,25x16
16	26800390	2	341C	BEARING 55x120	CUSCINETTO 55x120
17	40000410	1	158G	O-RING 70x100	GUARNIZIONE O-R 70x100
18	79012293	2	300S	SUPPORT	SUPPORTO
19	79012300		198S	SHIM 1	SPESSORE 1
	79012301		198S	SHIM 0,5	SPESSORE 0,5
	79012302		198S	SHIM 0,2	SPESSORE 0,2
22	79013289	1	300S	SUPPORT	SUPPORTO
23	79013293	1	265C	COVER	COPERCHIO
24	79013334	1	16A	SHAFT	ALBERO
25	79013339	1	341C	BEARING	CUSCINETTO

CENTRAL DRIVE GEARS – RUOTISMI RIDUZIONE CENTRALE – ENGRENAGES DE REDUCTION CENTRALE 4
 ZAHNRAEDER F. MITTELACHSUNTERSETZUNG – ENGRANAJES DE REDUCCION CENTRAL

B4.04

N.T.R. 158 - 13.03.1987
 604.01.081.03

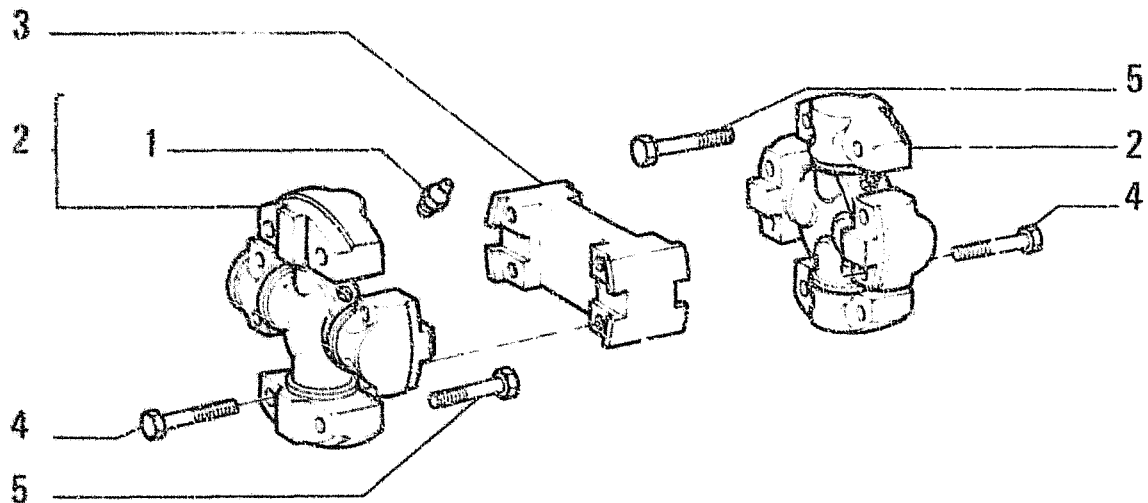

I T E M	PART NUMBER	Q T Y	TRANS CODE	DESCRIPTION	DESCRIZIONE
1	13407211	1	60I	GREASE FITTING 10x1	INGRASSATORE 10x1
2	76002604	2	320C	SPIDER - ASSEMBLY	CROCIERA - COMPLETO
3	79017076	1	85F	YOKE	FORCELLA
4	79017077	8	40V	SCREW	VITE
5	70929049	8	40V	SCREW D1160	VITE D1160
	79028402	8	40V	SCREW C1160	VITE C1160

79028904

PROPELLER SHAFT - ALBERO DI TRASMISSIONE - ARBRE DE TRANSMISSION -
 UERBERTRAGUNGSWELLE - ARBOL DE TRANSMISION

B3.16

N.T.R. 191 - 20.02.1990

604.01.081.04

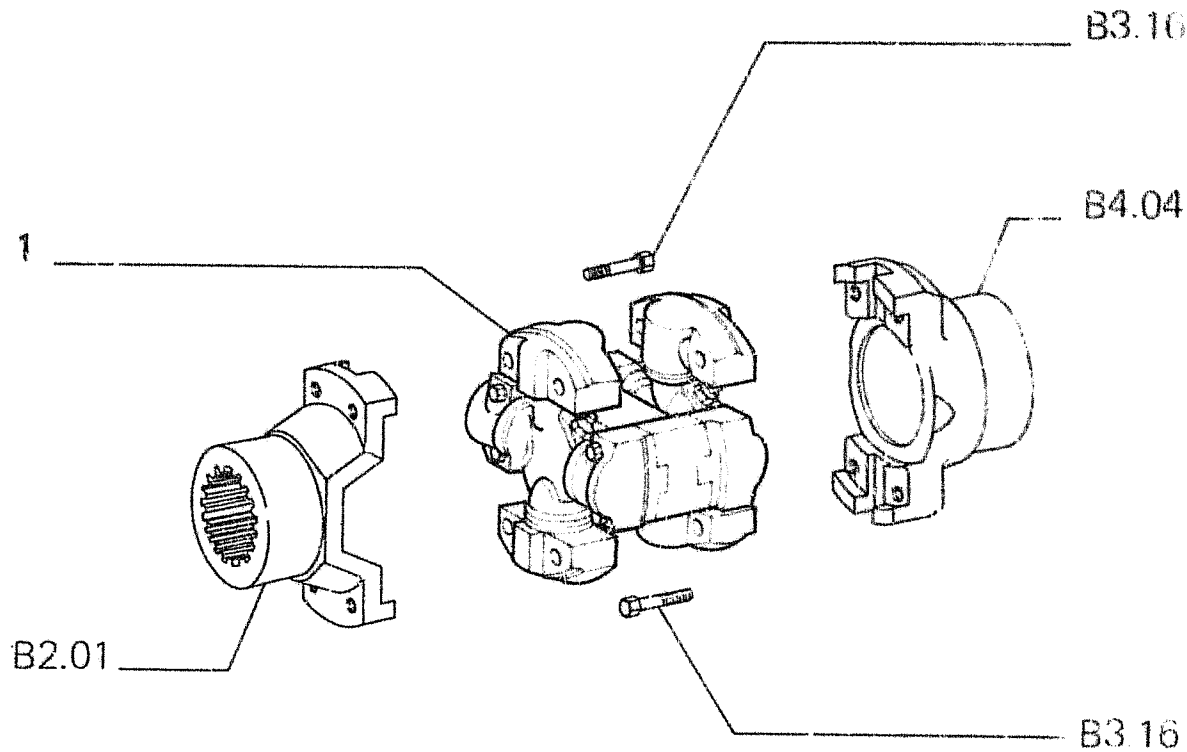

ITEM	PART NUMBER	QTY	TRANS CODE	DESCRIPTION	DESCRIZIONE
1	79028904	1	23A	DRIVE SHAFT - ASSEMBLY SEE SGP. B3.16	ALBERO TRASMISSIONE - COMPLETO VEDERE SGR. B3.16

TRANSMISSION TO AXLE PROPELLER SHAFT - TRASMISSIONE TRA CAMBIO E PONTE - TRANSMISSION ENTRE B.V. ET PONT - UEBERTRAGUNG ZWISCHEN GETRIEBE UND HINTERACHSE - ARBOL DE TRANSMISION DEL CAMBIO AL PUENTE

1

B3.01

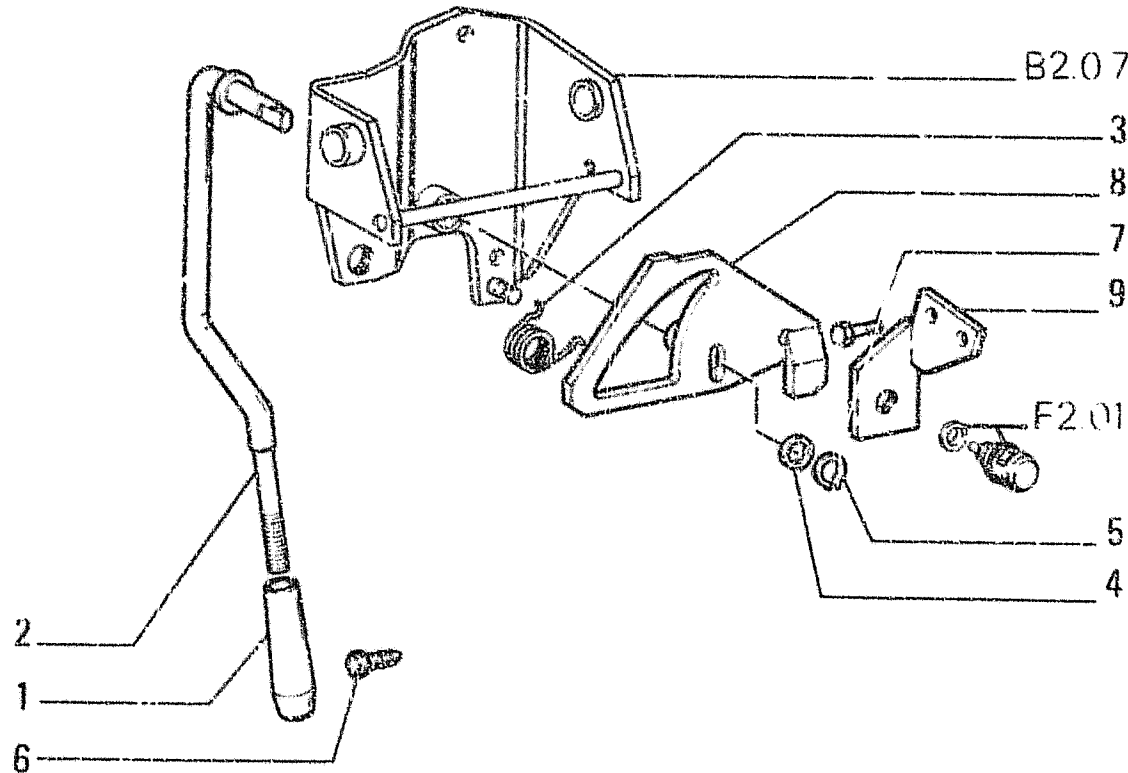

ITEM	PART NUMBER	QTY	TRANS CODE	DESCRIPTION	DESCRIZIONE
1	4977072	1	25I	HANDGRIP C1168	IMPUGNATURA C1168
	76006064	1	25I	HANDGRIP D1168	IMPUGNATURA D1168
2	4984830	1	45L	LEVER	LEVA
3	4985332	1	100M	SPRING	MOLLA
4	10520101	1	131R	WASHER 14,4x26	ROSETTA 14,4x26
5	11066276	1	51A	LOCKRING 12,9x1	ANELLO DI SICUREZZA 12,9x1
6	14567080	1	121B	RUBBER STUD 8,5x14	BOTTONE DI GOMMA 8,5x14
7	16043131	2	40V	SCREW 8x1,25x14	VITE 8x1,25x14
8	79022803	1	105P	PLATE	PIASTRA
9	79022804	1	300S	SUPPORT	SUPPORTO

TRANSMISSION LOCK-UP DEVICE - DISPOSITIVO BLOCCAGGIO CAMBIO - DISPOSITIF DE BLOCAGE DE BOITE DE VITESSES - GETRIEBESPERRE - ENCLAVAMIENTO DEL CAMBIO

B2.38

N.T.R. 152 - 28.11.1986
604.01.081.02

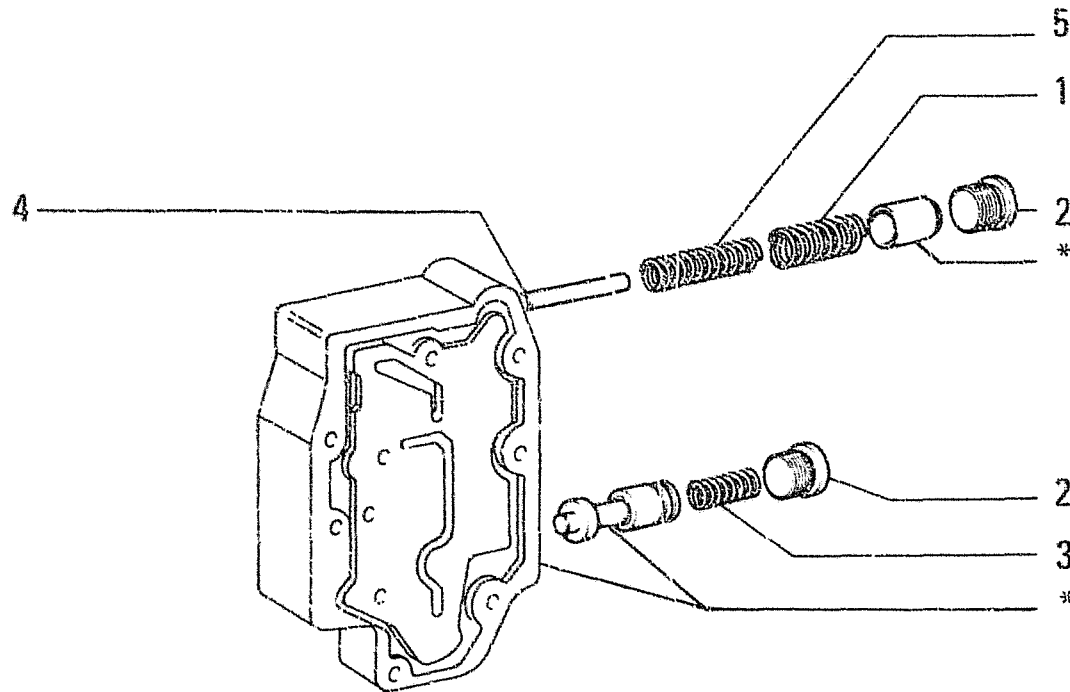

ITEM	PART NUMBER	QTY	TRANS CODE	DESCRIPTION	DESCRIZIONE
1	73118128	2	10GM	SPRING	MOLLA
2	73118329	4	50T	PLUG	TAPPO
3	79060003	2	100M	SPRING	MOLLA
4	79060016	2	80P	PIN	PERNO
5	79060017	2	100M	SPRING	MOLLA

PARTS MARKED * ARE NOT SUPPLIED AS SPARES
 I PARTICOLARI CONTRASSEGNA TI CON * NON
 VENGONO FORNITI DI RICAMBIO

D1510 tel. n. 250905 →

79060010
 MODULATING VALVE - VALVOLA MODERATRICE - VALVE MODERATRICE - HEMMVENTIL -
 VALVULA MODERADORA

B2.34/A

N.T.R. 200 - 15.10.1990
 604.01.081.05

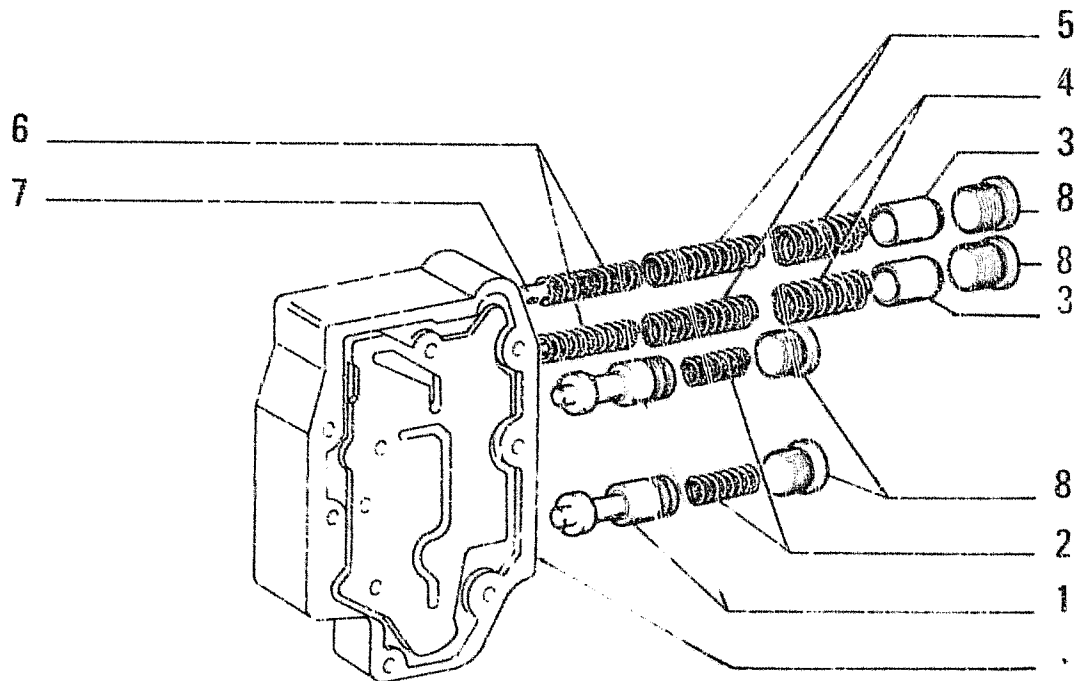

ITEM	PART NUMBER	QTY	TRANS CODE	DESCRIPTION	DESCRIZIONE
1	73118125	2	90A ROD		ASTA
2	73118126	2	100M SPRING		MOLLA
3	73118127	2	10V VALVE		VALVOLA
4	73118128	2	100M SPRING		MOLLA
5	73118129	2	100M SPRING		MOLLA
6	73118130	2	100M SPRING		MOLLA
7	73118131	2	80P PIN		PERNO
8	73118329	4	50T PLUG		TAPPO

PARTS MARKED * ARE NOT SUPPLIED AS SPARES
 I PARTICOLARI CONTRASSEGNA TI CON * NON
 VENGONO FORNITI DI RICAMBIO

C1510 → tel. n. 250904

73118123
 MODULATING VALVE - VALVOLA MODERATRICE - VALVE MODERATRICE - HEMMVENTIL -
 VALVULA MODERADORA

B2 34
 N.T.R. 200 - 15.10.1990
 604.01.081.05

D1510 tel. n. 250905 →

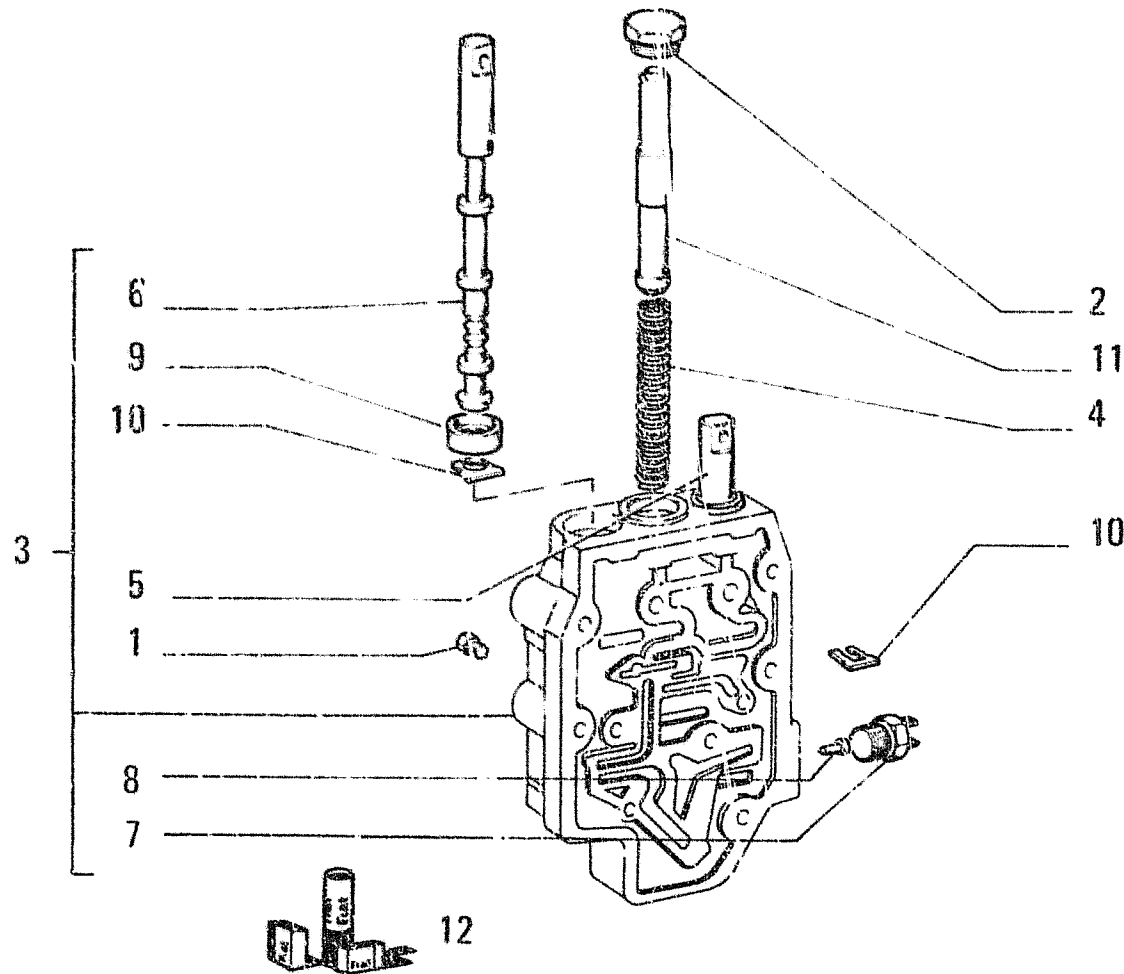

ITEM	PART NUMBER	QTY	TRANS CODE	DESCRIPTION	DESCRIZIONE
1	70919134	3	50T PLUG		TAPPO
2	70924290	1	50T PLUG		TAPPO
3	79060013	1	300C BODY - ASSEMBLY		CORPO - COMPLETO
4	73117875	1	100M SPRING		MOLLA
5	79060014	1	90A ROD		ASTA
6	79060015	1	90A ROD		ASTA
7	73118115	1	75I SWITCH		INTERRUTTORE
8	73118116	1	80P PIN		PERNO
9	73118117	2	158G O-RING		GUARNIZIONE O-R
10	73118118	3	45F CLIP		FERMATILLO
11	73118119	1	90A ROD		ASTA
12	79055160	1	1K KIT SEE PAGE 9		KIT V.L.D PAG 9

79060012

CONTROL VALVE - DISTRIBUTORE -- DISTRIBUTEUR -- STEUERGERAET - DISTRIBUIDOR

B2.33/A

N.T.R. 191 - 20.02.1990

604.01.081.04

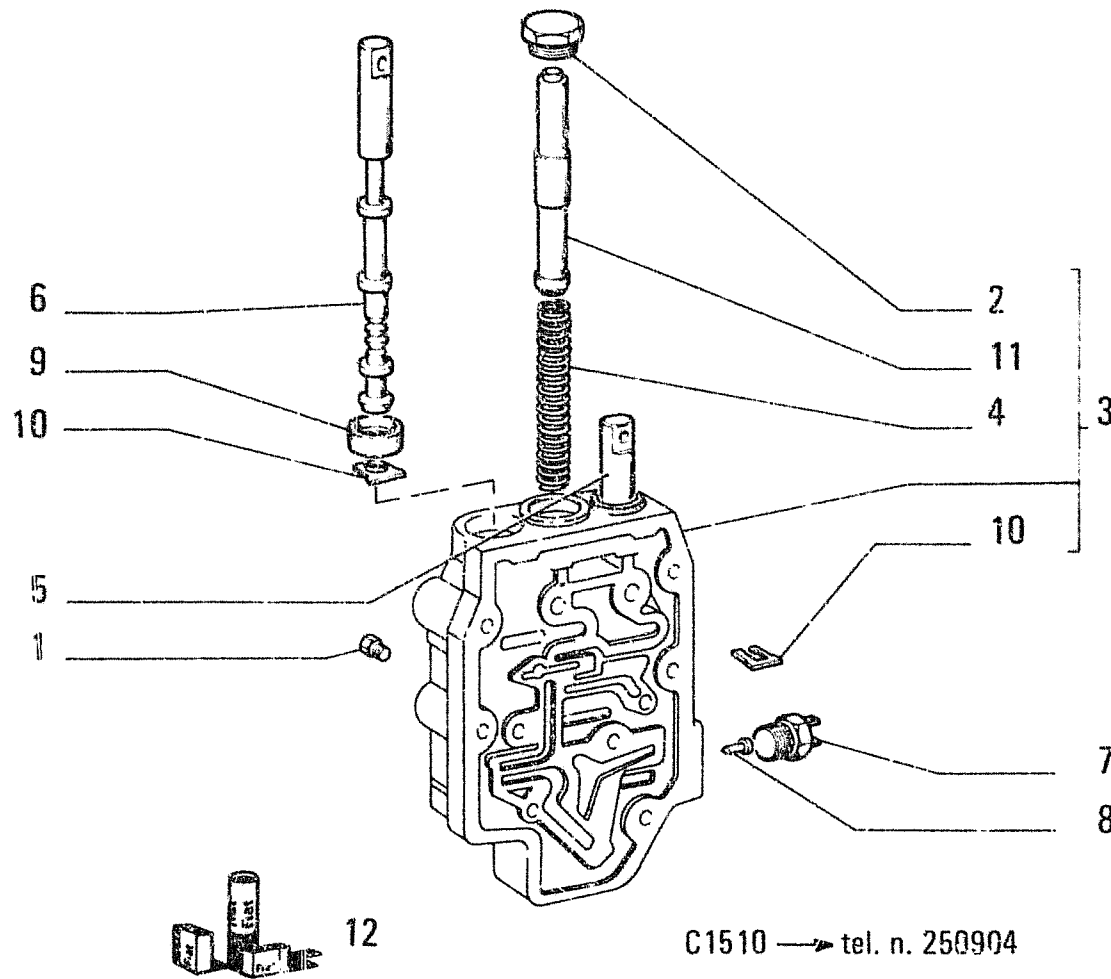

ITEM	PART NUMBER	QTY	TRANS CODE	DESCRIPTION	DESCRIZIONE
1	70919134	5	50T PLUG		TAPPO
2	70924290	1	50T PLUG		TAPPO
3	73117074	1	300C BODY - ASSEMBLY		CORPO - COMPLETO
4	73117875	1	100M SPRING		MOLLA
5	73118113	1	90A ROD		ASTA
6	73118114	1	90A ROD		ASTA
7	73118115	1	75I SWITCH		INTERRUTTORE
8	73118116	1	80P PIN		PERNO
9	73118117	2	158G O-RING		GUARNIZIONE O-R
10	73118118	3	45F CLIP		FERMAGLIO
11	73118119	1	90A ROD		ASTA
12	79055160	1	1K KIT SEE PAGE 9		KIT VED. PAG 9

79030262
 CONTROL VALVE - DISTRIBUTORE - DISTRIBUTEUR - STEUERGERAET - DISTRIBUIDOR

1 B2.33
 N.T.R. 191 - 20.02.1990
 604.01.081.04

DESIGNAZIONE BASE	BASIC DESIGNATION	DESIGNATIONS-BASES	GRUNDBEZEICHNUNGEN	DENOMINACIONES BASE
111V	VALVOLA ASPIRAZIONE	INTAKE VALVE	SOUPAPE DE ADMISSION	VALVULA DE ASPIRACION
1118	BRACCIO ABBATTIMENTO (AD)		BRAS ABATTAGE (AD)	
1119	BRACCIO ABBATTIMENTO (BD)		BRAS ABATTAGE (BD)	
112C	CAVO MASSA	GROUND CABLE	FIL DE MAS	CABLE DE MASA
112F	FUSO A SNODO	STEERING KNUCKLE	FLISEE	PUNTA DE EJE
112P	PIASTRINA ISOLANTE	INSULATING PLATE	PLAQUETTE ISOLANTE	PLACA AISLANTE
112S	SEPARATORE D'ARIA E VAPORE	AIR AND STEAM SEGREGATOR	SEPARATEUR D AIR ET DE VAPEUR	SEPARADOR DE AIRE Y VAPOR
112S			SCHUBPLATTE (AD)	VALVULA DE DESCARGA
112V	VALVOLA SCARICO	EXHAUST VALVE	SOUPAPE D'ECHAPPEMENT	
1120	PIASTRA DI SPINTA PER AD		PLAQUE DE POUSSEE POUR AD	
1124	TILT IDRAULICO (HA)	HYDRAULIC TILT (HA)	TILT HYDRAULIQUE (HA)	TILT IDRAULICO (HA)
1128	TILT-PITCH (HA)	TILT-PITCH (HA)	TILT-PITCH (HA)	
113B	BOZZELLO CARRUCOLA	SHEAVE BLOCK	POULIE	GARRUCHA
113F	FUSO	STUB SHAFT	FUSEE	MANGUETA
113G	GUANTI	GLOVES	GANTS	GUANTES
113M	MONOLEVA	SINGLE LEVER	LEVIER UNIQUE	MONOPALANCA
113P	PIASTRINA DI SICUREZZA	LOCKPLATE	PLAQUETTE FREIN	CHAPITA DE SEGURIDAD
113S	SERBATOIO OLIO	OIL RESERVOIR	RESERVOIR D HUILE	DEPOSITO ACEITE
113T	TESTA CILINDRI	CYLINDER HEAD	CULASSE DE CYLINDRE	TAPA DE CILINDROS
113V	VALVOLA DI ANTICIPO	ADVANCE VALVE	SOUPAPE D AVANCE	VALVULA DE AVANCE
1130	ATTACCO RAPIDO			
1135	PIASTRA DI SPINTA PER BD		PLAQUE DE POUSSEE POUR BD	
1138	TILT-PITCH	TILT-PITCH	TILT-PITCH	
114P	PIASTRINA DI COMANDO	DRIVE LINK	PLAQUE DE COMMANDE	PLACA DE ARRASTRE
114S	SERBATOIO COMBUSTIBILE	FUEL TANK	RESERVOIR DE COMBUSTIBLE	TANQUE COMBUSTIBLE
115G	GUARDONE PER BENNA	SPILL GUARD	REHAUSSE DE GODET	PLACA DE EXTENSION DEL CUCHARON
115G				
115M	MONTANTE	PILLAR	MONTANTE	MONTANTE
115S	SERBATOIO	TANK	RESERVOIR	DEPOSITO
116M	MONTATOIO	STEP PLATE	MARCHEPIED	ESTRIBO
116R	RIVESTIMENTO	COVERING	REVETEMENT	REVESTIMIENTO
116S	SERBATOIO CON VALVOLE	RESERVOIR W/VALVE	RESERVOIR ET SOU- PAPES	DEPOSITO CON VAL- VULAS
116S				
116T	TESTA DEL GIUNTO SFERICO	SOCKET	JOINT A ROTULE	ARTICULACION DE BOTULA
116T				
1160	BLOCCAGGIO BRACCI	BOOM LOCK	BLOCAGE BRAS	ANCLAJE DE BRAZO
1161	BLOCCAGGIO BENNA	BUCKET LOCK	BLOCAGE DU GODET	ANCLAJE DE LA CUCHARA
117R	RIVESTIMENTO ISOLANTE	INSULATION	REVETEMENT ISOLANT	FORRO AISLANTE
117S	SERBATOIO A DEPRESSIONE	VACUUM TANK	RESERVOIR DEPRES- SEUR	DEPOSITO DE VACIO
117S				

	DESIGNAZIONE BASE	BASIC DESIGNATION	DESIGNATIONS-BASES	GRUNDBEZEICHNUNGEN	DENOMINACIONES BASE
1170	INDICATORE POSIZIONE BENNA	BUCKET LEVEL INDICATOR	MISE A NIVEAU DU GODET	SCHAUFELSTELLUNGSANZEIGER	NIVELACION DE LA CUCHARA
1171	POSIZIONATORE AUTOMATICO BENNA	BUCKET LEVELER	MISE A NIVEAU AUTOMAT GODET	AUTOMAT SCHAUFEL-RUECKSTELLUNG	NIVELACION AUTOMATICA CUCHARA
118P	PIASTRINA MAGNETICA	MAGNETIC PLAQUE	PLAQUETTE MAGNETIQUE	MAGNETBLECH	IMAN
118P					
118S	SERRAFILO	TERMINAL SCREW	SERRE-FIL	ANSCHLUSSKLEMME	BORNE
1181	DISPOSITIVO KICK-OUT	BOOM KICK-OUT	ARRET AUTOMATIQUE BRAS	AUTOMAT HUBAB-SCHALTUNG	LIMITE AUTOMATICO DEL BRAZO
119M	MORSETTIERA	CONNECTION BLOCK	PLAQUE DE JONCTION	KLEMMLEISTE	CAJA DE CONTACTOS
119T	TESTA	HEAD	TETE	KOPF	CABEZA
120A	AUTOPILOTA	AUTOPILOT	AUTOPILOTE	SCHALTSTEUERGRUPPE	AUTOPILOTO
120B	BOTTONE	BUTTON	BOUTON	KNOPF	BOTON
120G	GUARNIZIONE PIANA	GASKET	JOINT	FLACHDICHTUNG	GUARNICION
120M	MORSETTO ELETTRICO	TERMINAL CONNECTOR	BORNE	KABELKLEMME	AGARRADERA
120P	PIATTELLO	PLATE	COUPELLE	TELLERSCHEIBE	PLATILLO
120R	ROCCETTO	HEEL	BOBINE	ZUENDSPULE	BOBINA
120S	SERRATURA	LOCK	SERRURE	SCHLOSS	CERRADURA
120T	TESTA DI REGISTRO	ADJUSTING SLEEVE	EMBOUT DE REGLAGE	EINSTELLBUECHSE	TUERCA DE REGLAJE
1200	BRACC. CARICATORE LUNGHI	LONG BOOM	BRAS LONG	LANGER LADEARM	
121B	BOTTONE DI GOMMA	RUBBER STUD	BOUTON CAOUTCHOUC	GUMMIBOLZEN	PITON DE CAUCHO
121C	CHIUSURA LAMPO	SNIP FASTENER	FERMETURE ECLAIR	REISSVERSCHLUSS	CIERRE DE CREMALLERA
121C					
121M	MORSETTO \ MANO	HAND VICE	ETAU A MAIN	KLEMMBACKE	TORNILLO DE MANO
121P	PIATTELLO DELLA PUNTERIA	TAPPET PLATE	PASTILLE DE	DIS"ANZSCHEIBE	PLATILLO DE EMPU
121P					
121S	SEPARATORE DI CONDENSA	WATER SEGREGATOR	SEPARATEUR D'EAU	KONDENSWASSER-	SEPARADOR DE AGUA
121S					
122F	FINO AL MOTORE IDRAULICO...	UP TO HYDRAULIC MOTOR...	JUSQU'AU MOTEUR HYDRAULIQUE	ABSCHIEDER	HASTA EL MOTOR HIDRAULICO
122G	GUARNIZIONE	SEAL	GARNITURE	BIS HYDRAULIKMOTOR	GUARNICION
122P	PIGNONE	PINION	PIGNON	DICHTUNG	PINON
123F	FINO AL RIDUTTORE...	UP TO REDUCTION GEAR...	JUSQU'AU REDUCTEUR	RITZEL	HASTA EL REDUCTOR
123G	GUARNIZIONE TENUTA FRONTALE	SEAL ASSY	GARNITURE FRONTAL	BIS UNTERSETZUNGSGETRIEBE	SELLO
123P	PIGNONE CONICO	BEVEL PINION	PIGNON CONIQUE	LIFE TIME-DICHTUNG	PINON CONICO
123S	SERVOCOMANDO	SERVO-CONTROL	SERVO-COMMANDE	KEGELRITZEL	SERVOMANDO
124B	BRACCIOLO SEDILE	ARMREST	ACCOUDOIR DE SIEGE	SERVOSTEUERUNG	APOYABRAZO
124F	FINO AL ...	UP TO ...	JUSQU'AU ...	ARMLEHNE	HASTA EL
124M	MOTOPOMPA	MOTOR PUMP	POMPE A MOTEUR	BIS	BOMBA DE MOTOR
124P	PINZA AUTOCENTRANTE	COLLET	PINCE FENDUE	PUMPENAGGREGAT	PASADOR DE MUELLE
124S	SERVODISTRIBUTORE	SERVO-VALVE	SERVO-DISTRIBUTEUR	SPANNZANGE	SERVOVALVULA
125F	FORCA	FORK		VORSTEUERVENTIL	
125P	PINZA	PLIERS	PINCES	ZANGE	ALICATES
125S	SERVOFRENO	BRAKE BOOSTER	SERVO-FREIN	SERVOBREMSE	SERVOFRENO

DESIGNAZIONE BASE	BASIC DESIGNATION	DESIGNATIONS-BASES	GRUNDBEZEICHNUNGEN	DENOMINACIONES BASE
126F	FINO ALLA POMPA ...	UP TO PUMP ...	JUSQUA LA POMPE	HASTA LA BOMBA ...
126P	PINZA FRENO	CALIPER	ETRIER DE FREIN	ZAPATA DE FRENO
126S	SERVOFRIZIONE	CLUTCH-SERVO	SERVO-EMBRAYAGE	SERVOEMBRAGUE
127M	MOTORE IDRAULICO	HYDRAULIC MOTOR	MOTEUR HYDRAULIQUE	MOTOR HIDRAULICO
127P	PIOMBINO	LEAD SEAL	PLOMB	PRECINTO
127S	SERVOFRENO PNEUMO-IDRAULICO	AIR-HYDRAULIC ASSISTED BRAKE	SERVO-FREIN HYDRO-PNEUMATIQUE	SERVOFRENO PNEUMO-HIDRAULICO
127T				
1279	TUBAZ E COMANDO ATTREZZO ANT	FRONT ATTACH PIPING AND CONTR	TUYAUTERIE ET C DE OUTIL AV	
1280	TUBAZIONI POST (DAL DEVIATORE)	REAR PIPE (FROM DIVERTER VALV)		
1281	TUBAZIONI POST (DAL DISTRIB)	REAR PIPE (FROM CONTROL VALVE)		
1288	TUBAZIONI ATTREZZO ANT	FRONT ATTACHEMENT PIPING	CONDUITES D OUTIL AVANT	TUBERIA DEL UTIL ANTERIOR
129P	PISTA	RACE	PISTE	PISTA
130B	BRACCIO	ARM	BRAS	BRAZO
130C	CENTRALINA	CONTROL UNIT	DISPOSITIVE DE COMMANDE	CENTRAL
130F	FUNZIONE IDRAUL SUPPL	ADDITIONAL HYDRAULIC FUNCTION		
130M	MOTORE TERMICO	ENGINE	MOTEUR	MOTOR
130P	PISTONCINO	PLUNGER	PISTON	KOLBEN
130S	SERVOSTERZO	SERVODIRECTION	SERVODIRECTION	SERVOLENKUNG
130T	TESTATA	END PLATE	CULASSE	KOPFSTUECK
131F	FIRE SLEEVE	FIRE SLEEVE		
131R	ROSETTA	WASHER	RONDELLE	ARANDELA
131T	TESTATA CASSONE	END GATES	HAYON	TESTERO
132B	BRACCIO OSCILLANTE	SWINGING ARM	BALANCIER	BRAZO OSCILANTE
132F	FONDELLO ANT	HEAD	BOUT AVANT	TAPA ANTERIOR
132P	PISTONE	PISTON	PISTON	EMBOLO
132R	ROSETTA DI SICUREZZA	LOCKWASHER	RONDELLE FREIN	ARANDELA DE FRENO
132S	SENSORE	INDUCTIVE PROXIMITY SWITCHES	CAPTEUR	SENSORIO
133B	BRACCIO SOLLEVAMENTO	LIFT BOOM	BRAS DE LEVAGE	BRAZO LEVANTAMIENTO
133F	FONDELLO POST	BOTTOM	BOUT ARRIERE	TAPA POSTERIOR
133M	MOTORINO AVVIAMENTO	STARTER MOTOR	DEMARRIUR	MOTOR DE ARRANQUE
133R	ROSETTA DI TENUTA	SEAL	JOINT D ETANCHEITE	JUNTA HERMETICA
134M	MOTORINO	MOTOR	MOTEUR	MOTOR
135C	CERCHIO RUOTA	RIM	JANTE	LLANTA
135M	MOZZO	HUB	MOYEU	CUBO
135P	PLAFONIERA	CEILING LAMP	PLAFONNIER	PANTALLA
135S	SETTORE DENTATO	TOOTHED SECTOR	SECTEUR D'ENTEE	SECTOR RUEDA DENTADA
136S	SETTORE RUOTA MOTRICE	SPROCKET SECTOR	SECTEUR BARBOTIN MOTEUR	SECTOR RUEDA MOTRIZ
137M	MOTORINO ELETTRICO	ELECTRIC MOTOR	MOTEUR ELECTRIQUE	MOTOR ELECTRICO
138S	SETTORE DI RIFERIMENTO	REFERENCE SECTOR	CAPTEUR DE REFERENCE	PLACA DE REFERENCIAS
138S				

B

MECHANICAL TRANSMISSION • CLUTCH • TRANSMISSION • TRANSMISSION SHAFT • AXLES
TRASMISSIONE MECCANICA • FRIZIONE • CAMBIO • ALBERO DI TRASMISSIONE • PONTI
TRANSMISSION MECANIQUE • EMBRAYAGE • BOITE DE VITESSES • ARRIERE DE TRANSMISSION • PONTS
MECHANISCHE KRAFTÜBERTRAGUNG • KUPPLUNG • GETRIEBE • GELENKWELLE • ACHSEN
TRANSMISSION MECANICA • EMBRAGUE • CAMBIO • ARBOL DE TRANSMISSION • PUENTES

C

BRAKES (MECHANICAL OR HYDRAULIC) • FRENI (MECCANICI O IDRAULICI) • FREINS (MECANIQUES OU HYDRAULIQUES) • BREMSEN
(MECHANISCHE ODER HYDRAULISCHE) • FRENOS (MECANICOS O HYDRAULICOS)

D

FRAME • STEERING • SUSPENSIONS • WHEELS • UNDERCARRIAGE • HYDRAULIC TRANSMISSION
TELAIO • STERZO • SOSPENSIONI • RUOTE • CINGOLATURA • TRASMISSIONE IDRAULICA
CADRE • DIRECTION • SUSPENSIONS • ROUES • TRAIN DE ROULEMENT • TRANSMISSION HYDRAULIQUE
RAHMEN • LENKUNG • AUFHÄNGUNGEN • RÄDER • KETTENLAUFWERK • HYDRAULISCHER ANTRIEB
BASTIDOR • DIRECCIÓN • SUSPENSIÓN • RUEDAS • TREN DE RODAJE • TRANSMISSION HYDRAULICA

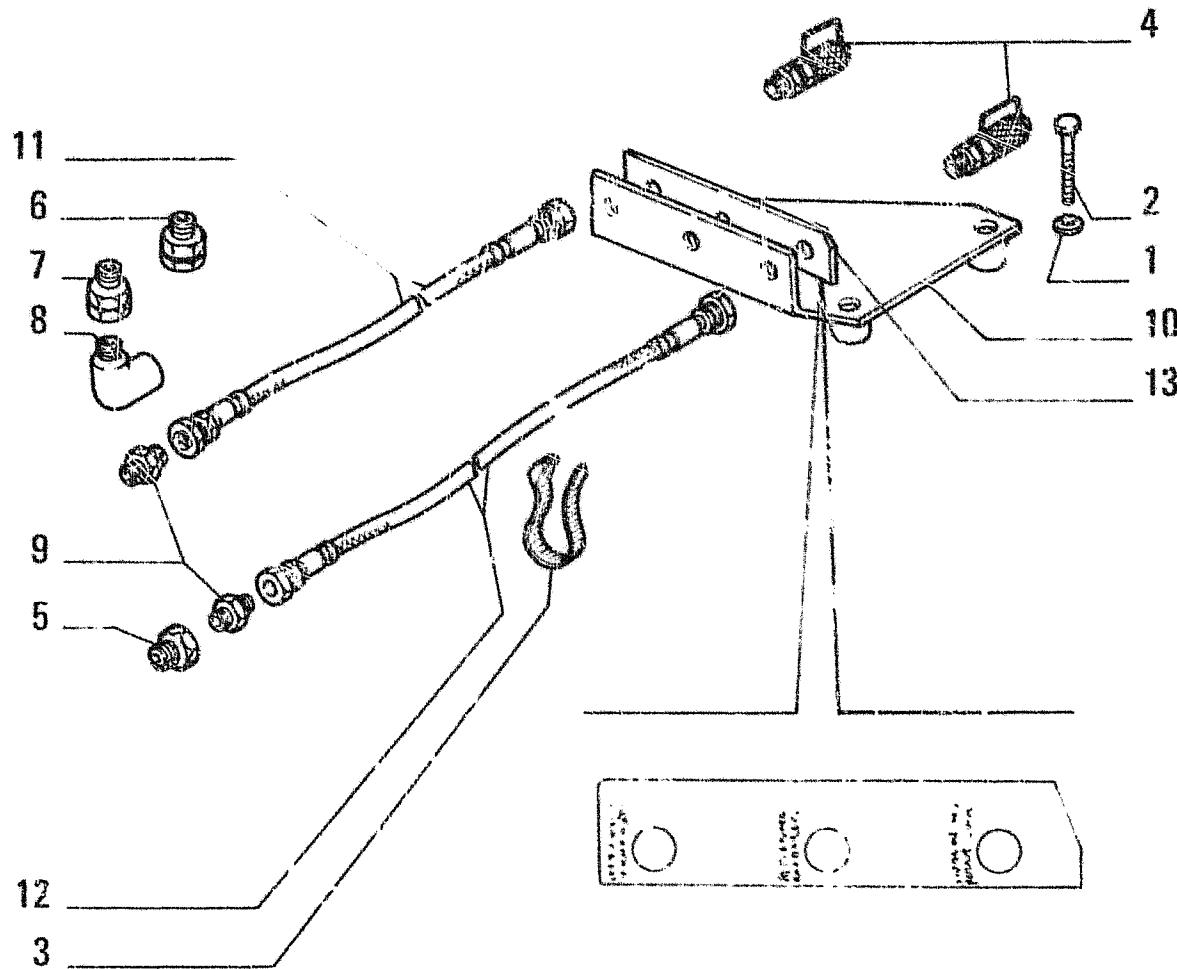

OPTIONAL
VARIANTE 30.0780.01.1

ITEM	PART NUMBER	QTY	TRANS CODE	DESCRIPTION	DESCRIZIONE
1	10571871	2	132R	LOCKWASHER 10,2x2,2	ROSETTA DI SICUREZZA 10,2x2,2
2	15970931	2	40V	SCREW 10x1,25x35	VITE 10x1,25x35
3	79013422	4	31F	CLAMP	FASCETTA
4	79032699	3	20°	FITTING	RACCORDO
5	79036507	1	20H	FITTING	RACCORDO
6	79036548	1	20F	FITTING	RACCORDO
7	79036549	1	20M	FITTING	RACCORDO
8	79036550	2	20P	FITTING	RACCORDO
9	79036564	3	20R	FITTING	RACCORDO
10	79036588	1	105P	PLATE	PIASTRA
11	79036591	1	192T	HOSE ASSY	TUBO FLESS.C/RACCORDI
12	79036592	2	192T	HOSE ASSY	TUBO FLESS.C/RACCORDI
13	79047637	1	65T	DECAL	TARGA

DIAGNOSTIC SYSTEM – DIAGNOSTICA CENTRALIZZATA – DIAGNOSTIC CENTRALISE' – ZENTRALE
FEHLERSUCHANLAGE – DIAGNOSTICO CENTRAL

B5.01

N.T.R. 114 - 16-01-1984
604.01.081.01

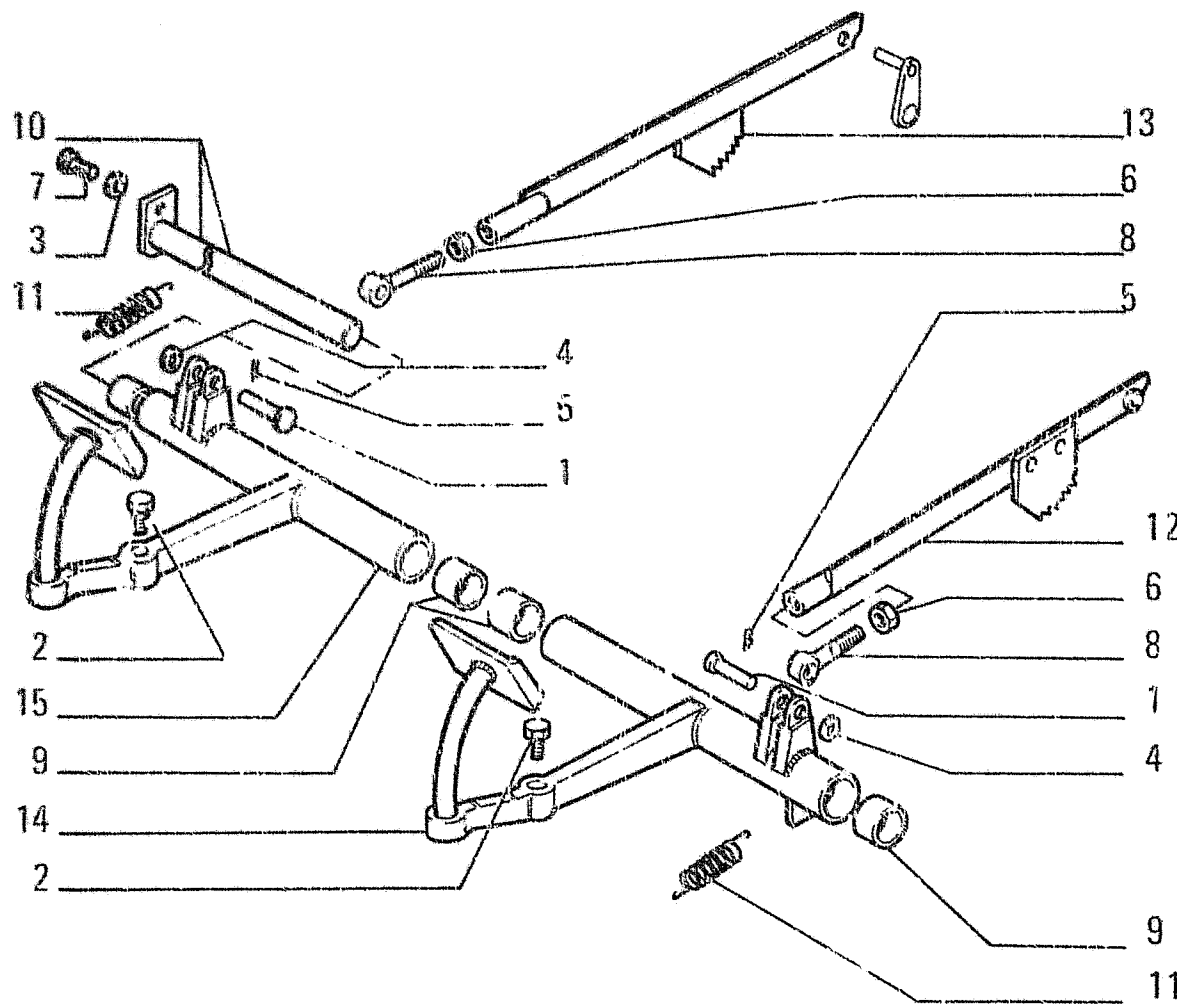

ITEM	PART NUMBER	QTY	TRANS CODE	DESCRIPTION	DESCRIZIONE
1	584009	2	80P	PIN C2939	PERNO C2939
	76016782	2	80P	PIN D2939	PERNO D2939
2	591420	2	61T	CUSHION PAD - IN ALTERNATIVE	TASSELLO ELASTICO - IN ALTERNATIVA
	79037282	2	60T	BLOCK - IN ALTERNATIVE B3335	TASSELLO - IN ALTERNATIVA B3335
3	10516671	1	132R	LOCKWASHER 8,1x2,2	ROSETTA DI SICUREZZA 8,1x2,2
4	10520101	2	324R	WASHER 14,4x26	ROSETTA 14,4x26
5	10734601	2	270C	COTTER PIN 2,7x27,6	COPIGLIA 2,7x27,6
6	10791321	2	10D	NUT 14x1,5x8	DADO 14x1,5x8
7	16043631	1	40V	SCREW 6x1,25x25	VITE 6x1,25x25
8	79003622	2	62E	TIEROD HEAD	ESTREMITA' DEL TIRANTE
9	79004903	4	95B	BUSHING	BOCCOLA
10	79012399	1	16A	SHAFT	ALBERO
11	79026134	2	100M	SPRING	MOILA
12	79027110	1	142T	TIEROD - LEFT	TIRANTE - SINISTRO
13	76016784	1	142T	TIEROD - RIGHT D2939	TIRANTE - DESTRO D2939
	79027126	1	142T	TIEROD - RIGHT C2939	TIRANTE - DESTRO C2939
14	76017737	1	60P	PEDAL - LEFT D2939	PEDALE - SINISTRO D2939
	79027197	1	60P	PEDAL - LEFT ASSEMBLY C2939	PEDALE - SINISTRO COMPLETO C2939
15	76017739	1	60P	PEDAL - RIGHT D2939	PEDALE - DESTRO D2939
	79027198	1	60P	PEDAL - RIGHT ASSEMBLY C2939	PEDALE - DESTRO COMPLETO C2939

BRAKE FOOT CONTROL - COMANDO A PEDALE FRENI - COMMANDE AU PIED DE FREINS -
 BREMSFUSSHEBEL - MANDO DEL FRENO DE PIE

C1.01

1

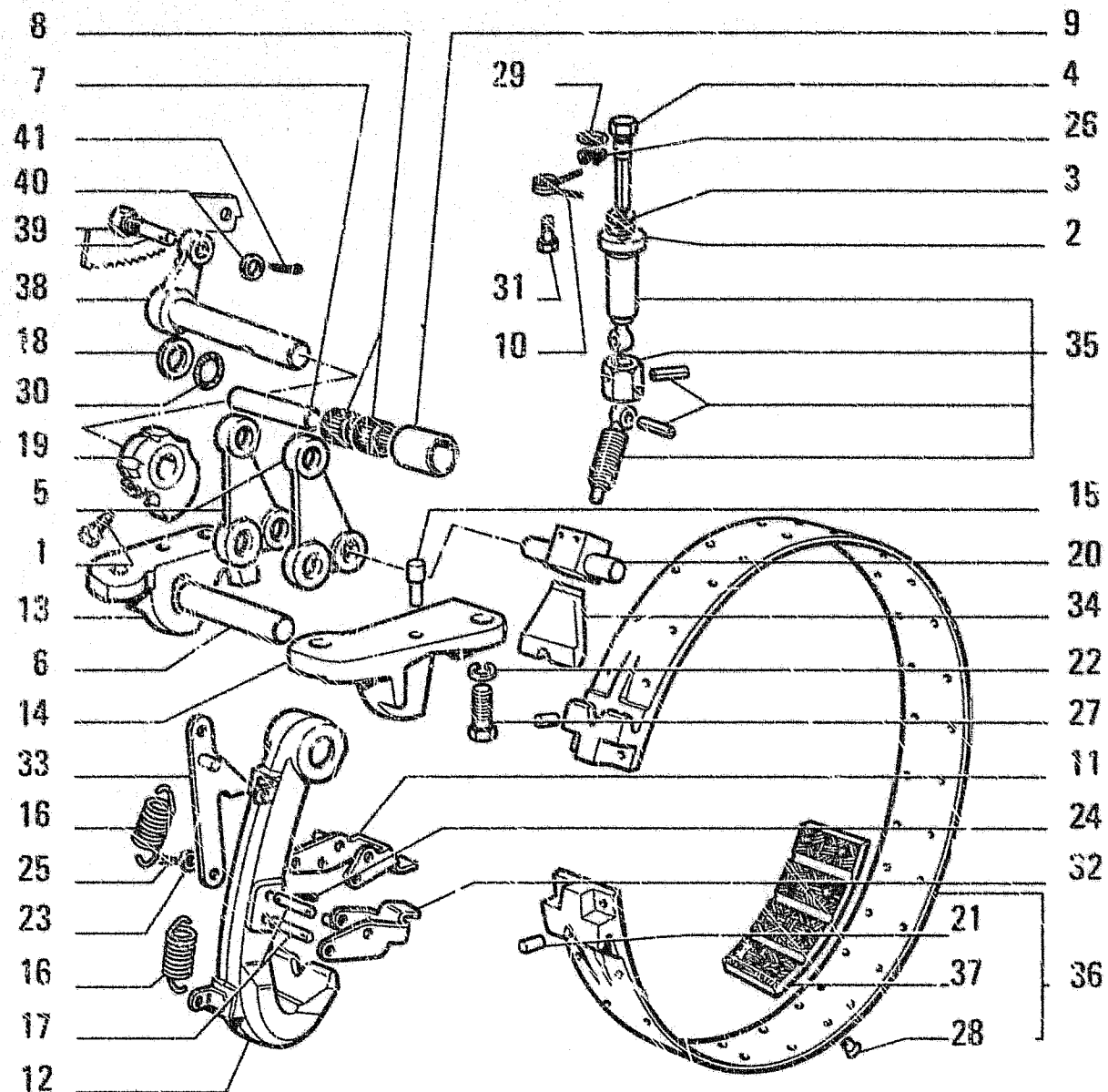

FIATALLIS FLY

ITEM	PART NUMBER	QTY	TRANS CODE	DESCRIPTION	DESCRIZIONE
1	586707	2	40V	SCREW	VITE
2	589320	2	131R	WASHER	ROSETTA
3	590523	2	132R	LOCKWASHER	ROSETTA DI SICUREZZA
4	597768	2	120T	ADJUSTING SLEEVE	TESTA DI REGISTRO
5	599305	4	45L	LEVER	LEVA
6	599307	2	80P	PIN	PERNO
7	4958134	2	80P	PIN - UPPER	PERNO - SUPERIORE
8	4958138	4	15G	CAGE	GARBIA
9	4958139	2	157R	ROLLER	RULLO
10	4958144	2	100M	SPRING	MOLLA
11	4966833	2	85F	YOKE - UPPER	FORCELLA - SUPERIORE
12	4966912	2	142T	TIEROD	TIRANTE
13	4966917	2	300S	SUPPORT - RIGHT	SUPPORTO - DESTRO
14	4966918	2	300S	SUPPORT - LEFT	SUPPORTO - SINISTRO
15	4966929	4	90G	DOWEL	GRANO
16	4967633	4	100M	SPRING	MOLLA
17	4968342	4	80P	PIN	PERNO
18	4970225	2	45A	RING	ANELLO
19	4982768	2	10E	ECCENTRIC C2939	ECCENTRICO C2939
20	79062223	2	10E	ECCENTRIC D2939	ECCENTRICO D2939
21	4983613	2	80P	PIN	PERNO
22	10489510	4	80P	PIN 6x12	PERNO 6x12
23	10517171	4	132R	LOCKWASHER 14,2x3,5	ROSETTA DI SICUREZZA 14,2x3,5
24	10519601	2	131R	WASHER 8,15x17	ROSETTA 8,15x17
25	10733601	8	270C	COTTER PIN 2,7x31,6	COPIGLIA 2,7x31,6
26	10734201	2	270C	COTTER PIN 1,7x18,5	COPIGLIA 1,7x18,5
27	11066376	2	51A	LOCKRING 13,8x1	ANELLO DI SICUREZZA 13,8x1

BRAKE FOOT CONTROL - COMANDO A PEDALE FRENI - COMMANDE AU PIED DE FREINS -
 BREMSFUSSHEBEL - MANDO DEL FRENO DE PIE

C1.01 2
 N.T.R. 191 - 20.02.1990
 604.01.081.04

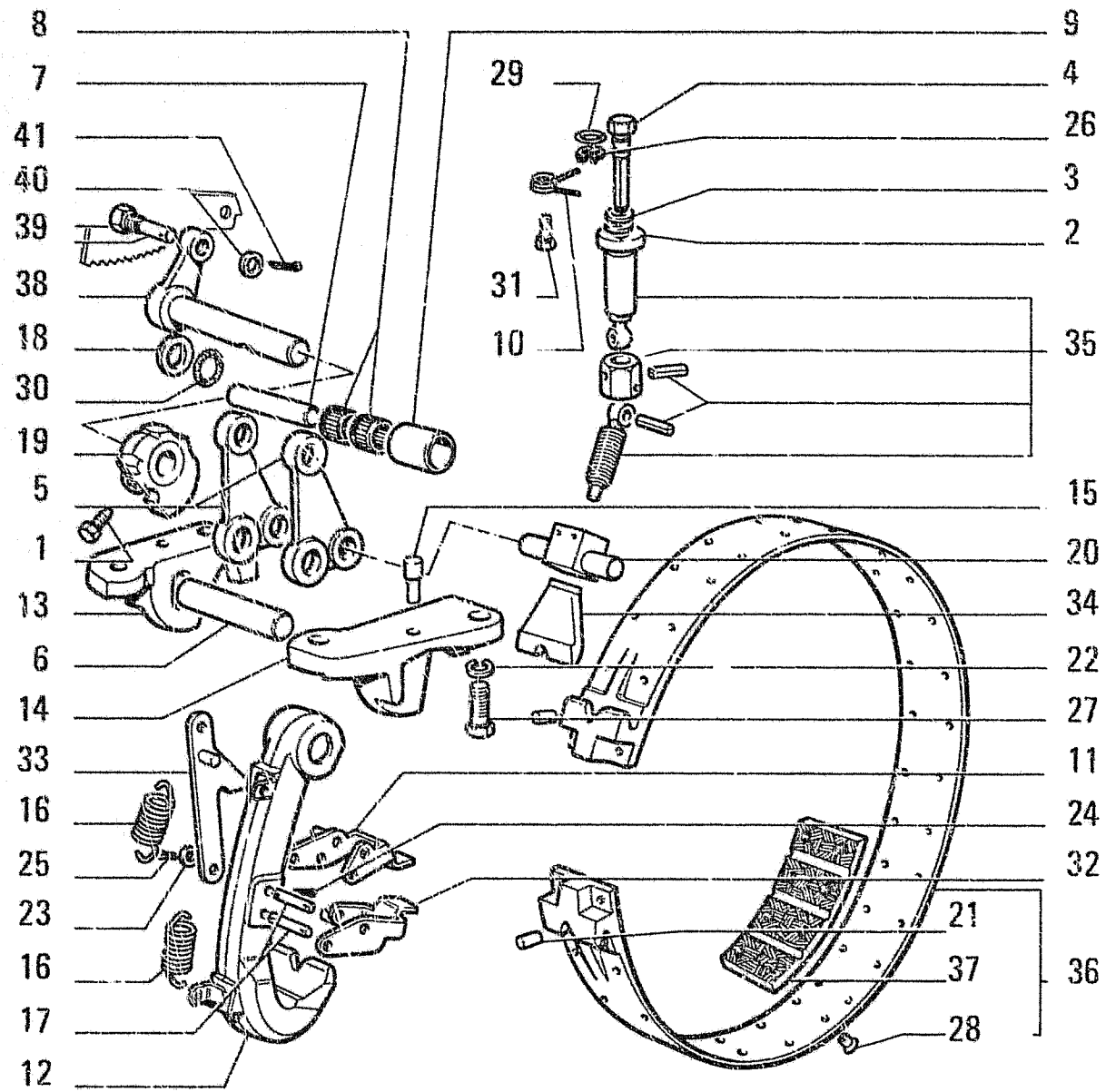

FIATALLIS FD7

ITEM	PART NUMBER	QTY	TRANS CODE	DESCRIPTION	DESCRIZIONE
27	11394331	4	40V	SCREW 14x1,5x40	VITE 14x1 5x40
28	13879640	100	55R	RIVET 4x10	RIBATTINO 4x10
29	14453180	2	158G	O-RING 1,78x12,42	GUARNIZIONE O-R 1 78x12,42
30	14463180	2	158G	O-RING 3,53x23,39	GUARNIZIONE O-R 3,53x23,39
31	15540431	2	40V	SCREW 12x1,25x30	VITE 12x1,25x30
32	76001883	2	85F	YOKE - LOWER	FORCELLA - INFERIORE
33	76001884	2	45L	LEVER	LEVA
34	76001885	2	238P	PUSH ROD	PUNTALE
35	76001887	2	40V	SCREW	VITE
36	79011575	2	24N	BRAKE BAND - ASSEMBLY	NASTRO FRENO - COMPLETO
37	79011576	10	24N	BRAKE BAND	NASTRO FRENO
38	79012426	2	45L	LEVER	LEVA
39	79025347	2	40V	SCREW	VITE
40	10520101	2	131R	WASHER 14,4x26	ROSETTA 14,4x26
41	10734601	2	270C	COTTER PIN 2,7x37,6	COPIGLIA 2,7x37,6

BRAKE FOOT CONTROL - COMANDO A PEDALE FRENI - COMMANDE AU PIED DE FREINS -
 BREMSFUSSHEBEL - MANDO DEL FRENO DE PIE

C1.01 2
 N.T.R. 191 - 20.02.1990
 604.01.081.04

L5

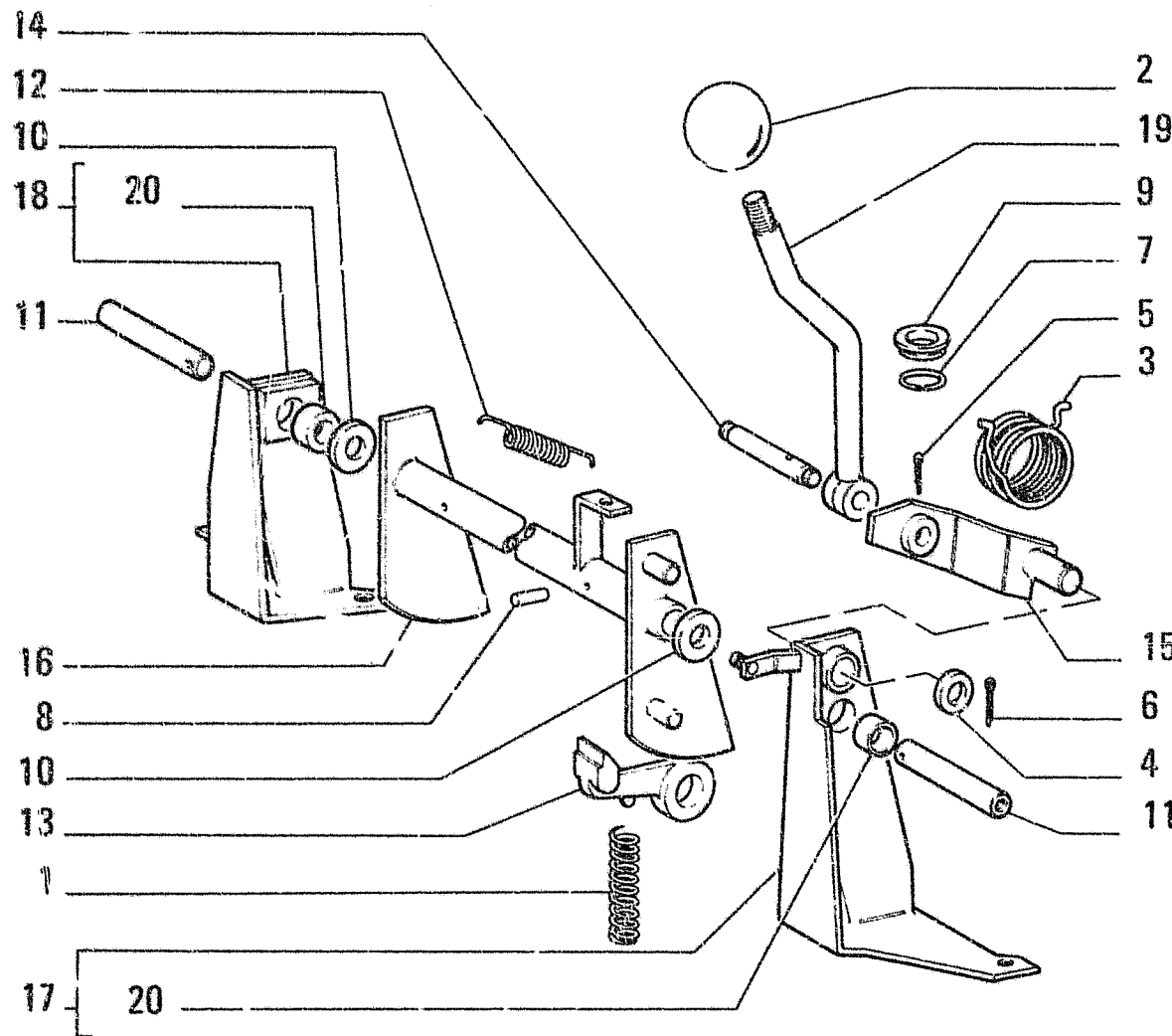

ITEM	PART NUMBER	QTY	TRANS CODE	DESCRIPTION	DESCRIZIONE
1	15480	2	100M	SPRING	MOLLA
2	4985147	1	25I	HANDGRIP	IMPUGNATURA
3	4985332	1	100M	SPRING	MOLLA
4	10520201	1	131R	WASHER 16,4x28	ROSETTA 16,4x28
5	10733601	1	270C	COTTER PIN 2,7x31,6	COPIGLIA 2,7x31,6
6	10734301	1	270C	COTTER PIN 2,7x37,6	COPIGLIA 2,7x37,6
7	13401176	1	51A	LOCKRING 20,2x24,2	ANELLO DI SICUREZZA 20,2x24,2
8	14168070	2	200S	PIN 6,4x22	SPINA 6,4x22
9	76004839	1	145G	GUIDE	GUIDA
10	79005965		198S	SHIM	SPESSORE
11	79012435	2	16A	SHAFT	ALBERO
12	79012869	1	100M	SPRING	MOLLA
13	79013164	2	83A	LATCHET	ARPIONE
14	79027107	1	80P	PIN	PERNO
15	79027136	1	45L	LEVER	LEVA
16	79027140	1	45L	LEVER	LEVA
17	79027146	1	300S	SUPPORT - LEFT ASSEMBLY	SUPPORTO - SINISTRO COMPLETO
18	79027147	1	300S	SUPPORT - RIGHT ASSEMBLY	SUPPORTO - DESTRO COMPLETO
19	79027160	1	45L	LEVER	LEVA
20	14549270	2	95B	BUSHING 16x22	BOCCOLA 16x22

C 2957 → Tel.n. 251767

HAND BRAKE CONTROL - COMANDO A MANO FRENI - COMMANDE DE FREINS A MAIN -
 HANDBREMSBETAETIGUNG - FRENO DE MANO

1

C1.35

N.T.R. 191 - 20.02.1990

604.01.081.04

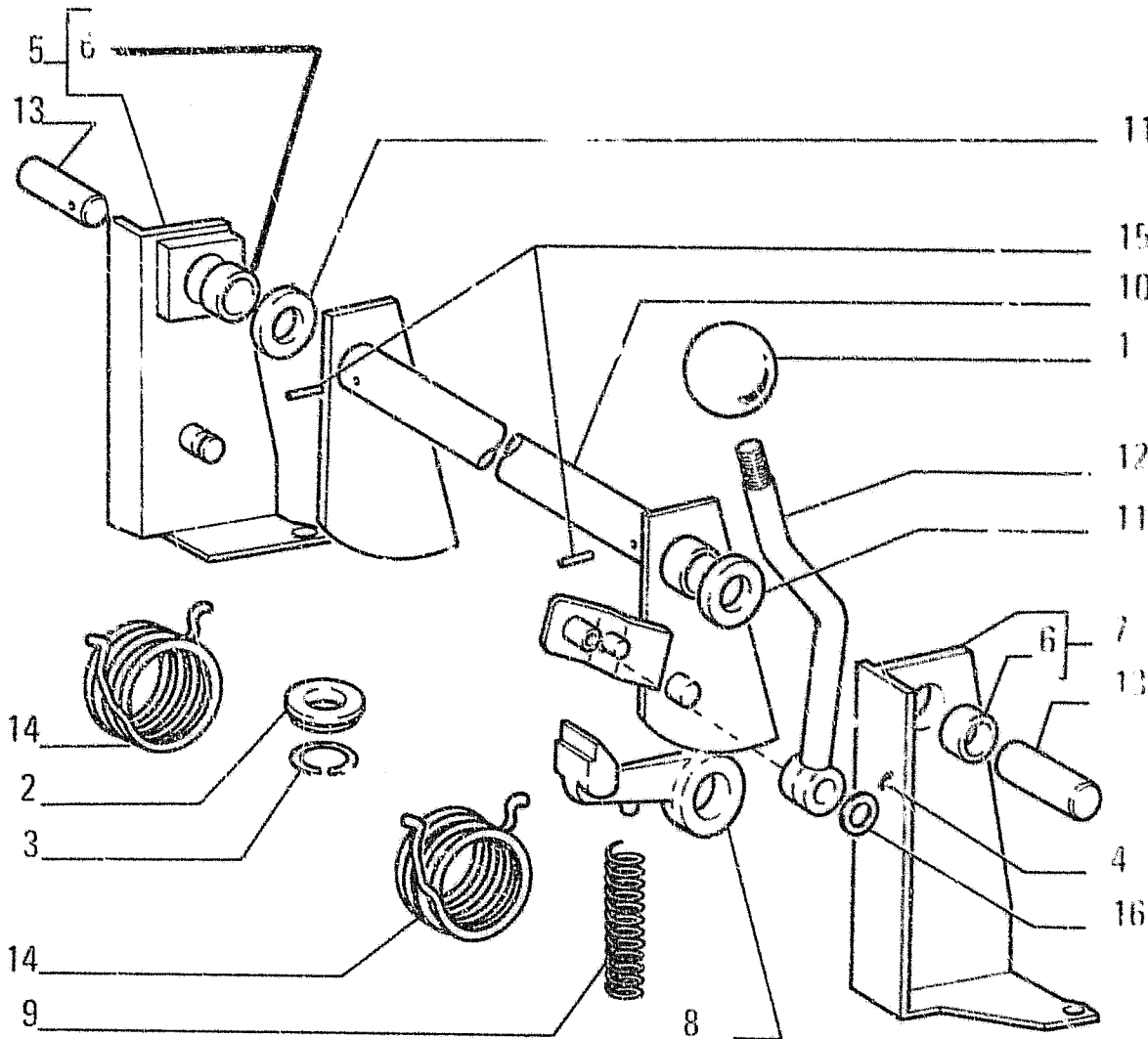

FIATALLIS FD7

C1.35/ A TAV. 1 PAG.1

ITEM	PART NUMBER	QTY	TRANS CODE	DESCRIPTION	DESCRIZIONE
1	4985147	1	25I	HANDGRIP	IMPUGNATURA
2	76004839	1	145G	GUIDE	GUIDA
3	13401176	2	51A	LOCKRING 20,2x24,2	ANELLO DI SICUREZZA 20,2x24,2
4	10733601	1	270C	COTTER PIN 2,7x31,6	COPIGLIA 2,7x31,6
5	76018203	1	300S	SUPPORT - RIGHT ASSEMBLY	SUPPORTO - DESTRO COMPLETO
6	14549270	2	95B	BUSHING 16x22	BOCCOLA 16x22
7	76018199	1	300S	SUPPORT - LEFT ASSEMBLY	SUPPORTO - SINISTRO COMPLETO
8	79013164	2	83A	RATCHET	ARPIONE
9	15480	2	100M	SPRING	MOLLA
10	76018207	1	45L	LEVER	LEVA
11	79005965	2	198S	SHIM	SPESSORE
12	76018214	1	45L	LEVER	LEVA
13	79012435	2	16A	SHAFT	ALBERO
14	4985332	1	100M	SPRING	MOLLA
15	14168070	2	200S	PIN 6,4x22	SPINA 6,4x22
16	10520001	1	131R	WASHER 12,2x22	ROSETTA 12,2x22

D 2957 Tel.n. 251768

HAND BRAKE CONTROL
HANDBREMSBETAETIGUNG

COMANDO A MANO FRENI
FRENO DE MANO

COMMANDE DE FREINS A MAIN

L7

C135 A

N.T.R. 191 - 20.02.1990

604.01.081.04

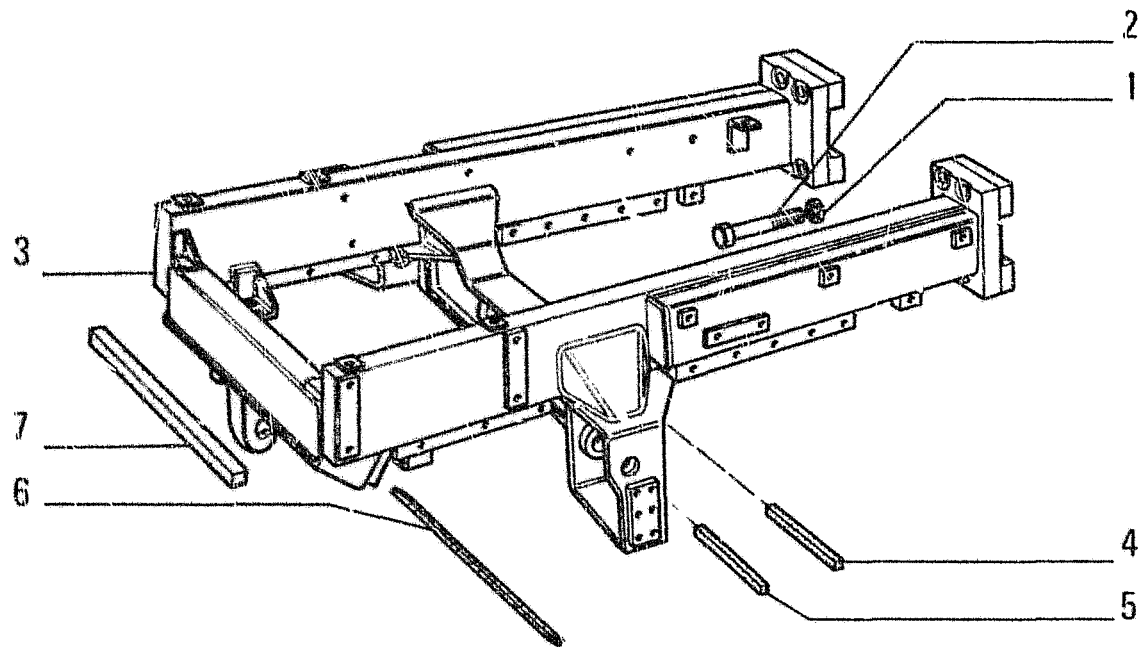

ITEM	PART NUMBER	QTY	TRANS CODE	DESCRIPTION	DESCRIZIONE
1	10572371	8	132R	LOCKWASHER 20,2x4	ROSETTA DI SICUREZZA 20,2x4
2	10960637	8	40V	SCREW 20x1,5x35	VITE 20x1,5x35
3	79029872	1	77T	MAIN FRAME - ASSEMBLY	TELAIO TRATTORE - COMPLETO
4	79029877	2	120G	GASKET	GUARNIZIONE PIANA
5	79029878	2	120G	GASKET	GUARNIZIONE PIANA
6	79029879	1	120G	GASKET	GUARNIZIONE PIANA
7	79029880	1	120G	GASKET	GUARNIZIONE PIANA

FRAME - TELAI0 - CHASSIS - RAHMEN - BASTIDOR

D1.01

L8

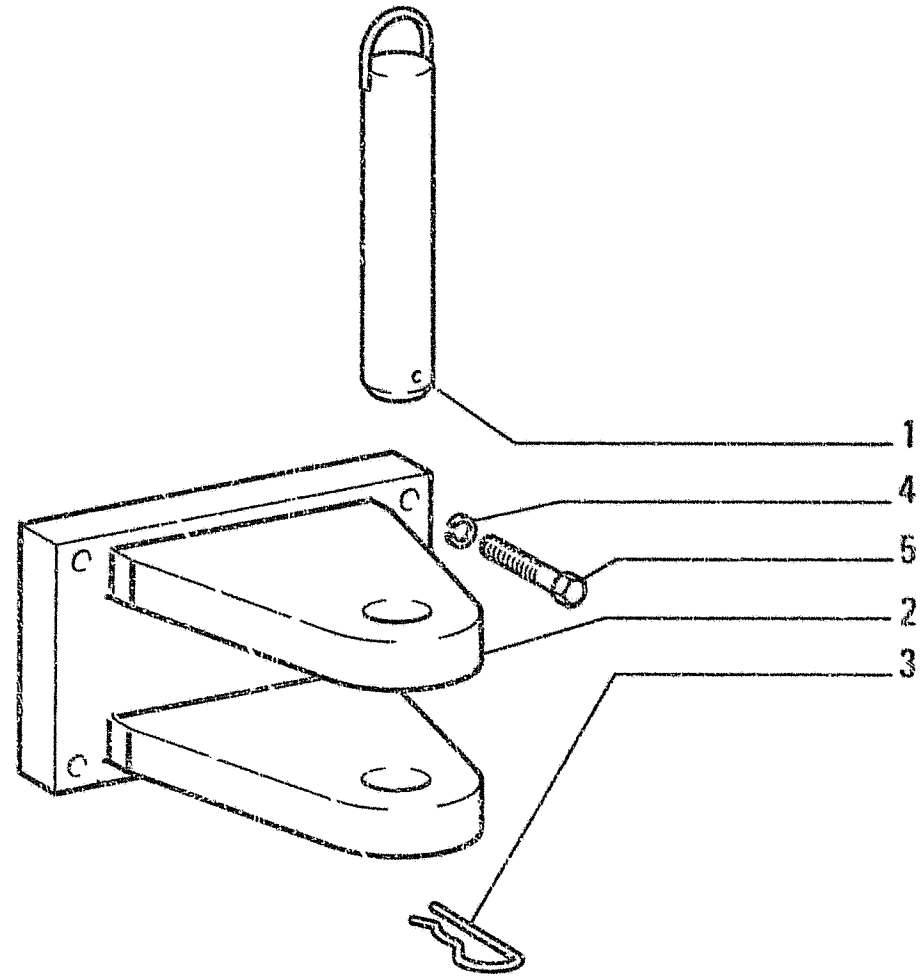

ITEM	PART NUMBER	QTY	TRANS CODE	DESCRIPTION	DESCRIZIONE
1	4966230	1	80P	PIN	PERNO
2	4976140	1	32G	TOW HOOK	GANCIO DI TRAINO
3	8268534	1	270C	COTTER PIN	COPIGLIA
4	10517471	4	132R	LOCKWASHER 20,2x1,5	ROSETTA DI SICUREZZA 20,2x1,5
5	15996037	4	40V	SCREW 20x1,5x240	VITE 20x1,5x240

TOWING DEVICE - ORGANO DI TRAINO - ORGANE D'ATTELAGE - ANHAENGERKUPPLUNG - BARRA DE ARRASTRE

D1.03

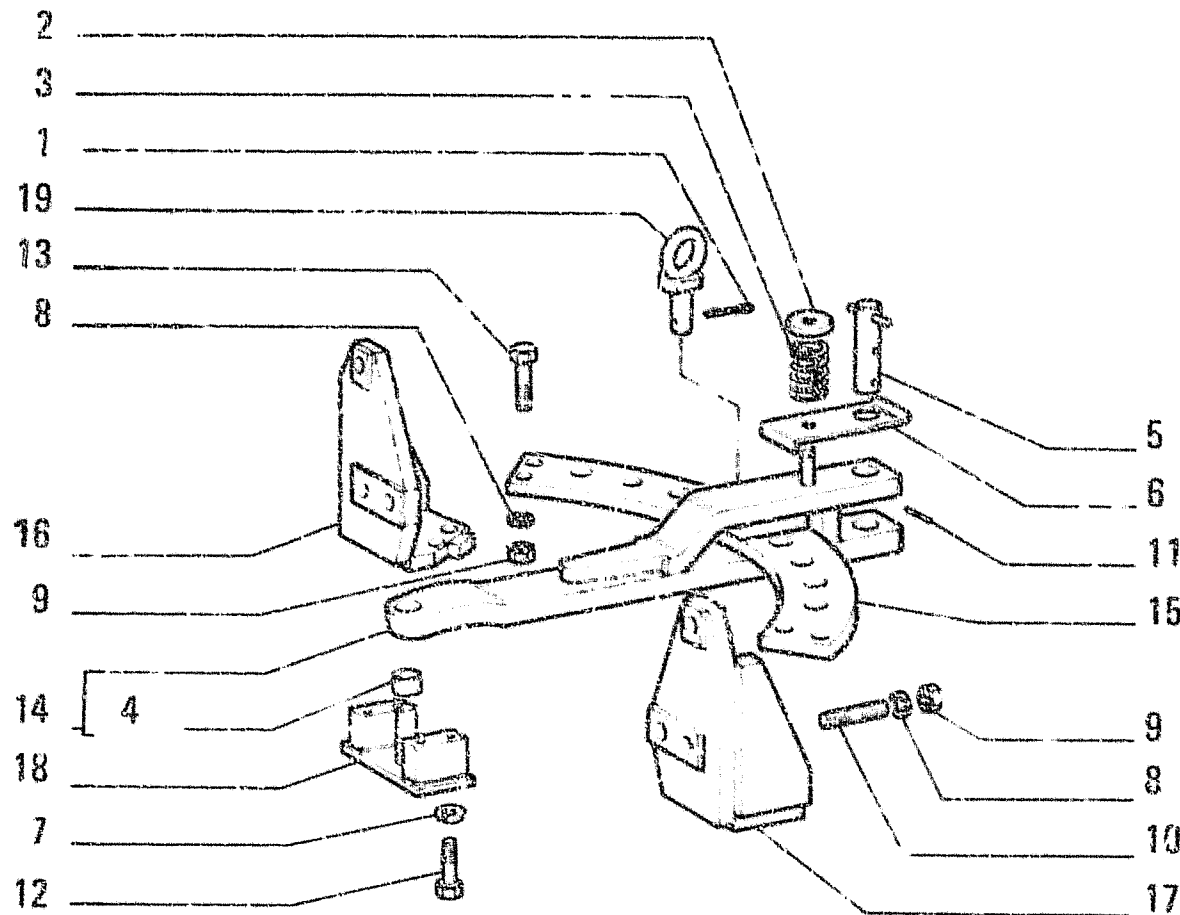

OPTIONAL
VARIANTE 30.0890.07.1

ITEM	PART NUMBER	QTY	TRANS CODE	DESCRIPTION	DESCRIZIONE
1	567406	2	270C	COTTER PIN	COPIGLIA
2	592934	1	60S	CUP	SCODELLINO
3	4951417	1	100M	SPRING	MOLLA
4	4971518	1	95B	BUSHING	BOCCOLA
5	4997139	1	80P	PIN	PERNO
6	4997141	1	225S	BRACKET	STAFFA
7	10517171	4	132R	LOCKWASHER 14,2x3,5	ROSETTA DI SICUREZZA 14,2x3,5
8	10517471	10	132R	LOCKWASHER 20,2x4,5	ROSETTA DI SICUREZZA 20,2x4,5
9	12164327	10	10D	NUT 20x1,5x16	DADO 20x1,5x16
10	13568637	6	210P	STUD 20x1,5x105	PRIGIONIERO 20x1,5x105
11	14601470	1	200S	PIN 5x32	SPINA 5x32
12	15977931	4	40V	SCREW 14x1,5x90	VITE 14x1,5x90
13	15989137	4	40V	SCREW 20x1,5x100	VITE 20x1,5x100
14	79019721	1	13B	DRAWBAR - ASSEMBLY	BARRA DI TRAINO - COMPLETO
15	79019722	1	181T	DRAWBAR FRAME	TRAVERSA DI TRAINO
16	79019723	1	80M	BRACKET - RIGHT	MENSOLA - DESTRO
17	79019730	1	80M	BRACKET - LEFT	MENSOLA - SINISTRO
18	79019731	1	225S	BRACKET	STAFFA
19	15629	1	80P	PIN	PERNO

TOWING DEVICE - ORGANO DI TRAINO - ORGANE D'ATTELAGE - ANHAENGERKUPPLUNG - BARRA DE ARRASTRE

D1.03/1

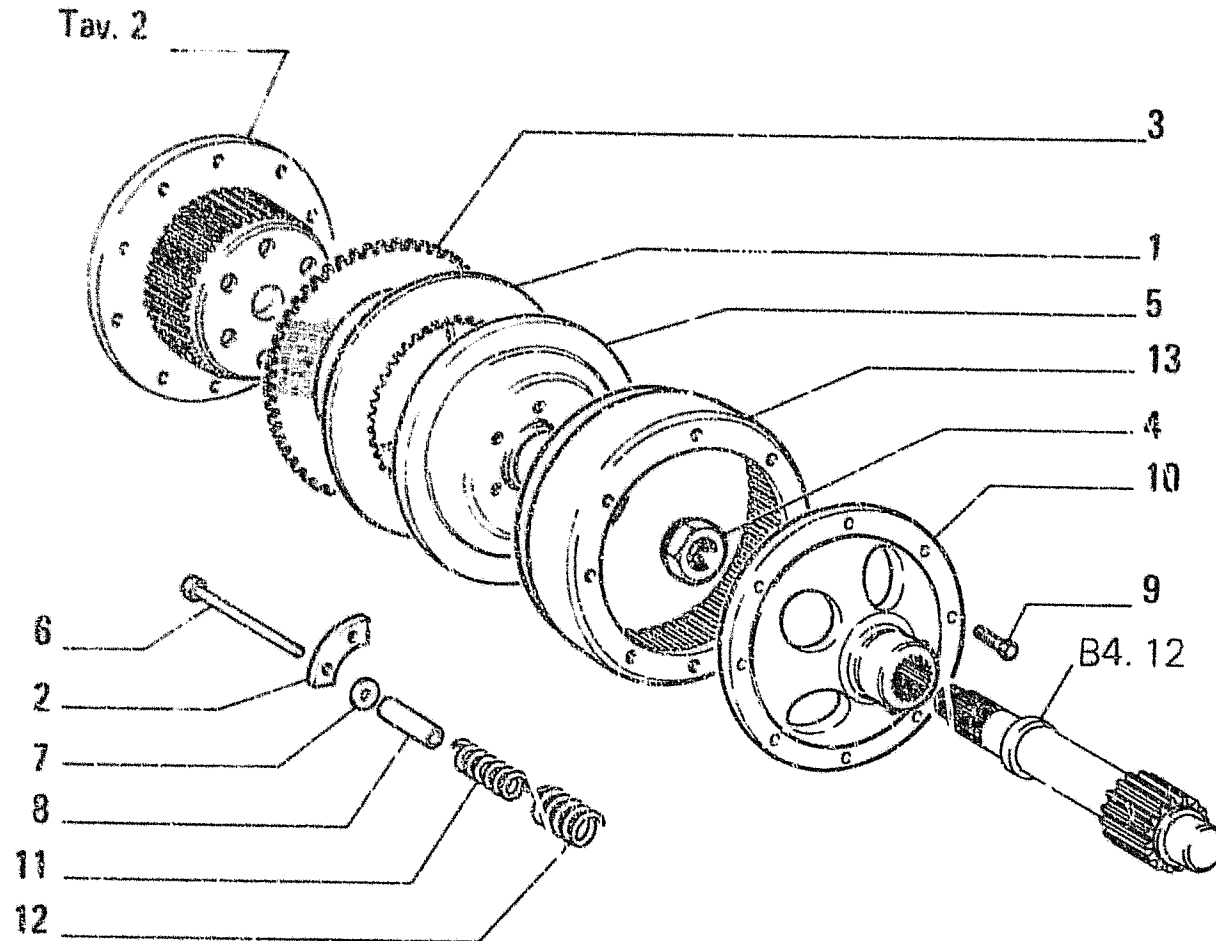

ITEM	PART NUMBER	QTY	TRANS CODE	DESCRIPTION	DESCRIZIONE
1	14687	20	60D	DISC	DISCO
	79039724	20	60D	DISC D2939	DISCO D2939
2	586750	6	113P	LOCKPLATE	PIASTRINA DI SICUREZZA
3	597258	20	60D	DISC C2939	DISCO C2939
	79077633	20	60D	DISC D2939	DISCO D2939
4	4965705	2	10D	NUT	DADIO
5	4968964	2	52A	PRESSURE PLATE	ANELLO SPINGIDISCO
6	4968965	12	184C	STUD	COLONNETTA
7	4968968	12	131R	WASHER	ROSETTA
8	4968969	12	75D	SPACER	DISTANZIALE
9	11274430	20	40V	SCREW 12x1,25x25	VITE 12x1,25x25
10	79012325	2	135M	HUB	MOZZO
11	79012327	12	100M	SPRING - INNER	MOLLA - INTERNO
12	79012328	12	100M	SPRING - OUTER	MOLLA - ESTERNO
13	79013345	2	20T	DRUM	TAMBURO

STEERING CLUTCHES - FRIZIONI DI STERZO - EMBRAYAGES DE DIRECTION - LENKREIBKUPPLUN-
GEN - EMBRAGUES DE DIRECCION

D2.20

1

N.T.R. 1S1 - 20.02.1990

604.01.081.04

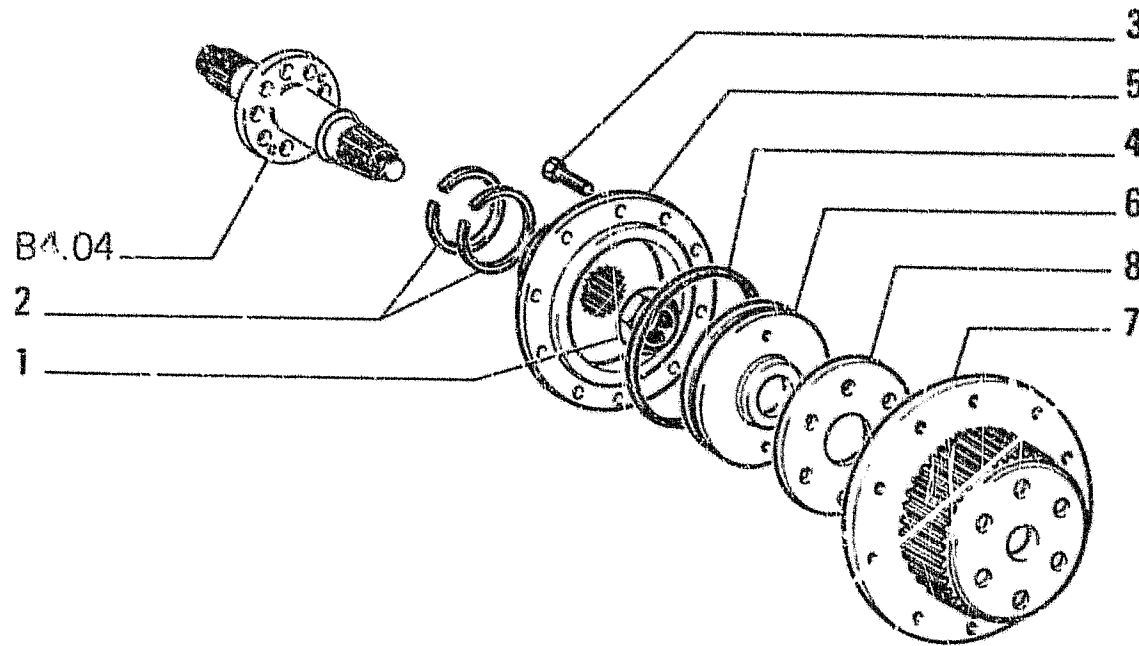

ITEM	PART NUMBER	QTY	TRANS CODE	DESCRIPTION	DESCRIZIONE
1	4965705	2	10D NUT		DADO
2	4967079	4	45A RING		ANELLO
3	14274430	16	40V SCREW 12x1,25x25		VITE 12x1,25x25
4	14167781	2	158G O-RING 3,53x158,3		GUARNIZIONE O-R 3,53x158,3
5	79012318	2	135M HUB		MOZZO
6	79012319	2	235S PISTON		STANTUFFO
7	79013343	2	20T DRUM C2939		TAMBURO C2939
	79034179	2	20T DRUM D2939		TAMBURO D2939
8	79013344	2	45A RING		ANELLO

STEERING CLUTCHES - FRIZIONI DI STERZO - EMBRAYAGES DE DIRECTION - LENKREIBKUPPLUN-
GEN - EMBRAGUES DE DIRECCION

D2.20

2

N.T.R. 191 - 20.02.1990

604.01.081.04

L12

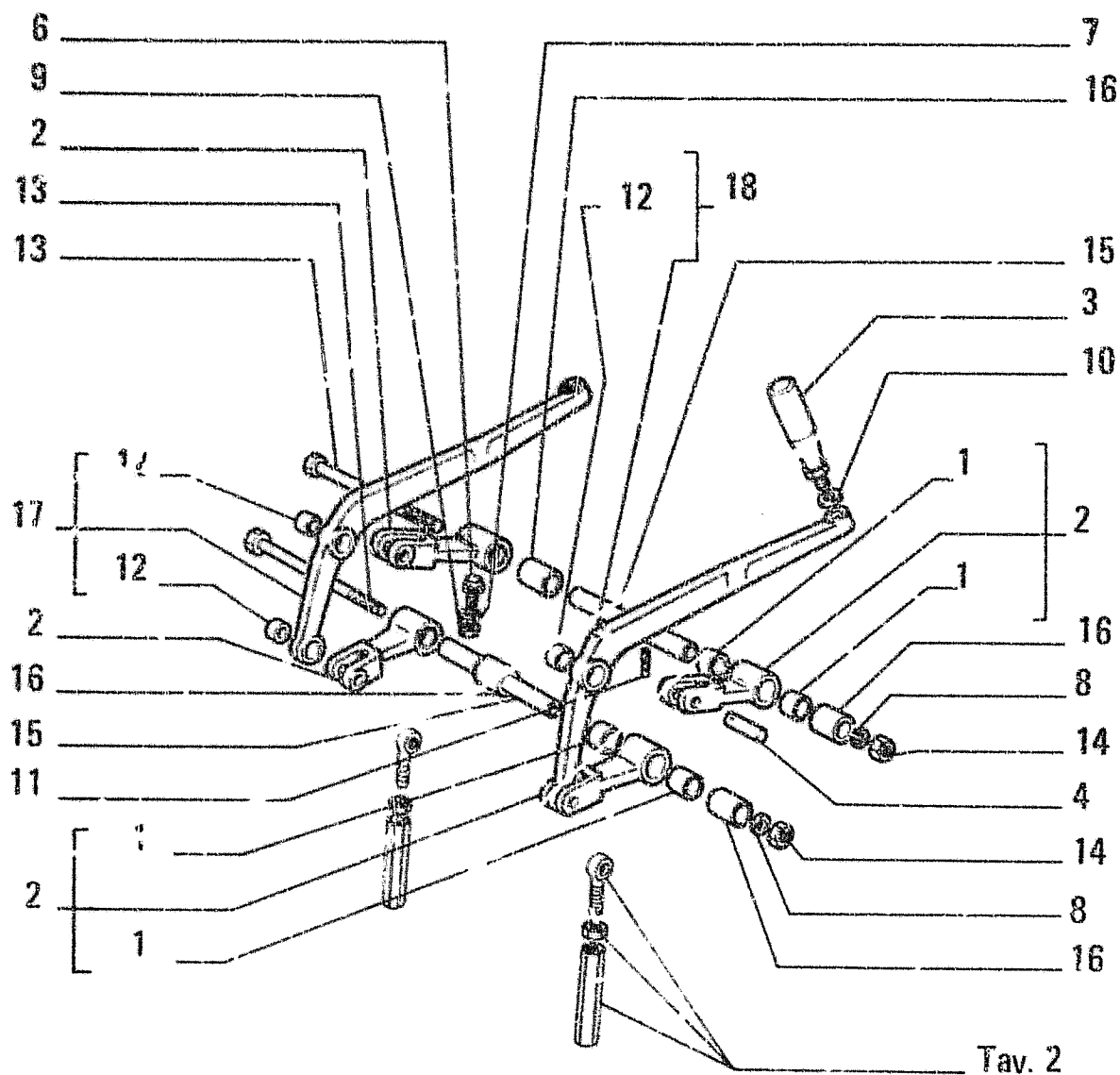

FIATALLIS FD7

D2.22 TAV. 1 P.22.1

ITEM	PART NUMBER	QTY	TRANS CODE	DESCRIPTION	DESCRIZIONE
1	546575	2	95B	BUSHING	BOCCOLA
2	587394	4	45L	LEVER - ASSEMBLY	LEVA - COMPLETO
3	587406	2	25I	HANDGRIP	IMPUGNATURA
4	587408	2	80P	PIN - UPPER	PERNO - SUPERIORE
6	591420	2	61T	CUSHION PAD - IN ALTERNATIVE	TASSELLO ELASTICO - IN ALTERNATIVA
	79037282	2	60T	BLOCK - IN ALTERNATIVE D3335	TASSELLO - IN ALTERNATIVA D3335
7	10516871	2	132R	LOCKWASHER 10x2,5	ROSETTA DI SICUREZZA 10x2,5
8	10517071	2	131R	WASHER 12,2x3,1	ROSETTA 12,2x3,1
9	12164711	2	10D	NUT 10x1,25x8	DADO 10x1,25x8
10	12605770	2	131R	WASHER 12,2x21,3	ROSETTA 12,2x21,3
11	14163170	2	200S	PIN 4,4x24	SPIGA 4,4x24
12	14543170	2	95B	BUSHING 12x17	BOCCOLA 12x17
13	15542331	2	40V	SCREW 12x1,25x170	VITE 12x1,25x170
14	16103621	2	10D	NUT 12x1,25x7	DADO 12x1,25x7
15	79005177	2	16A	SHAFT	ALBERO
16	79005198	4	75D	SPACER	DISTANZIALE
17	76019435	1	45L	LEVER - ASSEMBLY RIGHT IN ALTERNATIVE D3276	LEVA - COMPLETO DESTRO IN ALTERNATIVA D3276
	79019853	1	45L	LEVER - ASSEMBLY RIGHT IN ALTERNATIVE	LEVA - COMPLETO DESTRO IN ALTERNATIVA
18	76019434	1	45L	LEVER - ASSEMBLY LEFT IN ALTERNATIVE D3276	LEVA - COMPLETO SINISTRO IN ALTERNATIVA D3276
	79019855	1	45L	LEVER - ASSEMBLY LEFT IN ALTERNATIVE	LEVA - COMPLETO SINISTRO IN ALTERNATIVA

STEERING CLUTCHES RELEASE CONTROL - COMANDO DISINNESTO FRIZIONI DI STERZO - COMMANDE
DES EMBRAYAGES DE DIRECTION - AUSRUECKVORRICHTUNG DER LENDKREIBKUPPLUNGEN - MANDO
EMBRAGUES DE DIRECTION

D2.22

1

N.T.R. 200 - 15.10.1990

604.01.081.05

L13

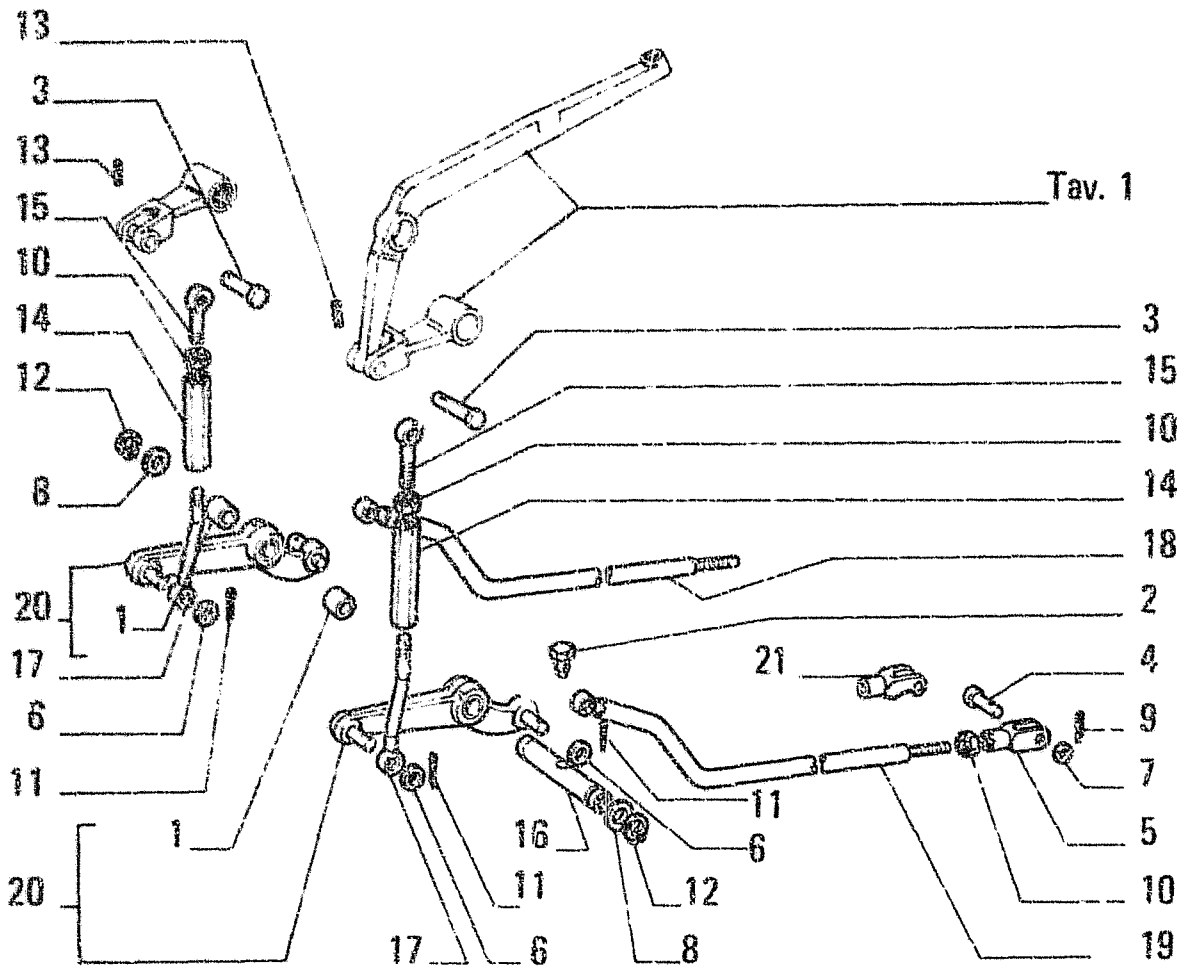

QTY	PART NUMBER	TRANS CODE	DESCRIPTION	DESCRIZIONE
4	546575	05B	BUSHING	BOCCOLA
1	586707	40V	SCREW	VITE
2	587408	00P	PIN - INNER	PERNO - INTERNO
2	10005010	80P	PIN 12x33	PERNO 12x33
2	10248471	85F	YOKE 12x1,5x12 C2912	FORCELLA 12x1,5x12 C2912
4	10520001	131R	WASHER 12,2x22	ROSETTA 12,2x22
2	10520021	131R	WASHER 12,2x22	ROSETTA 12,2x22
2	10731101	131R	WASHER 20,4x35	ROSETTA 20,4x35
2	10733601	270C	COTTER PIN 2,7x31,6	COPIGLIA 2,7x31,6
4	10791221	100	NUT 11x1,25x7	DADO 11x1,25x7
4	10796401	270C	COTTER PIN 2,7x27,6	COPIGLIA 2,7x27,6
2	11066876	51A	LOCKRING 13,5x1,2	ANELLO DI SICUREZZA 13,5x1,2
2	14163170	200S	PIN 4,4x24	SPINA 4,4x24
2	79002642	32M	ADJUSTMENT SLEEVE	MANICOTTO DI REGOLAZIONE
2	79026977	141T	THREADED TIEROD - UPPER	TIRANTE FILETTATO - SUPERIORE
1	79030902	16A	SHAFT	ALBERO
2	79030913	141T	THREADED TIEROD - FRONT	TIRANTE FILETTATO - ANTERIORE
1	79027068	141T	THREADED TIEROD - RIGHT	TIRANTE FILETTATO - DESTRO
1	79044956	141T	THREADED TIEROD - RIGHT	TIRANTE FILETTATO - DESTRO
1	79027070	141T	THREADED TIEROD - LEFT	TIRANTE FILETTATO - SINISTRO
1	79044958	141T	THREADED TIEROD - LEFT	TIRANTE FILETTATO - SINISTRO
2	591413	45L	LEVER - ASSEMBLY	LEVA - COMPLETO
2	79087422	85F	YOKE D2912	FORCELLA D2912

STEERING CLUTCHES RELEASE CONTROL -- COMANDO DISINNESTO FRIZIONI DI STERZO -- COMMANDE
 DES EMBRAYAGES DE DIRECTION -- AUSRUECKVORRICHTUNG DER LENDKREIBKUPPLUNGEN -- MANDO
 EMBRAGUES DE DIRECCION

D2.22

2

N.T.R 191 - 20.02.1990

804.01.081.04

L14

52A

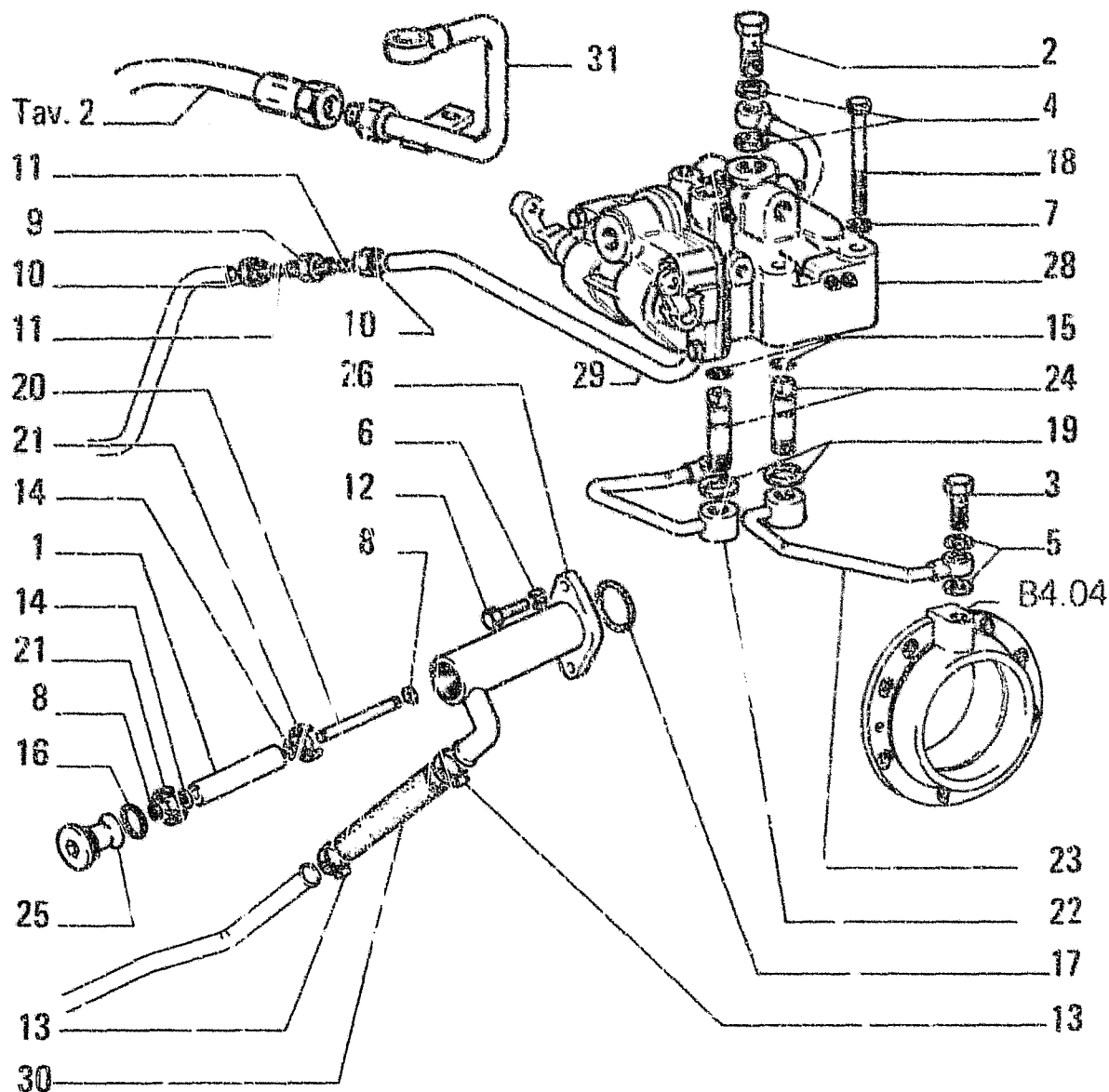

ITEM	PART NUMBER	QTY	TRANS CODE	DESCRIPTION	DESCRIZIONE
1	581492	1	54C	MAGNETIC ROD	CANDELA MAGNETICA
2	10182617	1	20R	FITTING 20x1,5x14	RACCORDO 20x1,5x14
3	10184317	2	20R	FITTING 14x1,5x27 C2939	RACCORDO 14x1,5x27 C2939
	79094063	2	20R	FITTING D2939	RACCORDO D2939
4	10257460	2	133R	SEAL 20,2x26	ROSETTA DI TENUTA 20,2x26
5	10279980	4	133R	SEAL 14,2x20	ROSETTA DI TENUTA 14,2x20
6	10516871	2	132R	LOCKWASHER 10x2,5	ROSETTA DI SICUREZZA 10x2,5
7	10517071	3	132R	LOCKWASHER 12,2x3,1	ROSETTA DI SICUREZZA 12,2x3,1
8	11065976	2	51A	LOCKRING 9,3x1	ANELLO DI SICUREZZA 9,3x1
9	11239111	1	20R	FITTING - INNER 24x1,5x24x1,5 C1520	RACCORDO - INTERNO 24x1,5x24x1,5 C1520
10	11262011	2	10D	NUT 24x1,5x20,5 C1520	DADO 24x1,5x20,5 C1520
11	11265511	2	158G	O-RING 16x19 C1520	GUARNIZIONE O-R 16x19 C1520
12	11306931	2	40V	SCREW 10x1,25x30	VITE 10x1,25x30
13	12173990	4	180C	COLLAR 25/45x12 C2906	COLLARE 25/45x12 C2906
	79083844	2	180C	COLLAR D2906	COLLARE D2906
14	12638660	2	131R	WASHER 10,2x18	ROSETTA 10,2x18
15	14452980	2	158G	O-RING 1,78x9,25	GUARNIZIONE O-R 1,78x9,25
16	14459080	1	158G	O-RING 2,62x44,12	GUARNIZIONE O-R 2,62x44,12
17	14459180	1	158G	O-RING 2,62x45,69	GUARNIZIONE O-R 2,62x45,69
18	15541431	3	40V	SCREW 12x1,25x80	VITE 12x1,25x80
19	79002004	4	90S	HALF RING C2939	SEMIANELLO C2939
	79094771	4	90S	HALF RING D2939	SEMIANELLO D2939
20	79010771	1	80P	PIN	PERNO
21	79010772	2	300S	SUPPORT	SUPPORTO
22	79012341	1	193T	TUBE - RIGHT C1519	TUBO RIGIDO - DESTRO

STEERING CLUTCHES HYDRAULIC CONTROL - COMANDO IDRAULICO FRIZIONI DI STERZO - COMMANDE HYDRAULIQUE DES EMBRAYAGES DE DIRECTION - HYDRAUL. STUERUNG DER LENKREIBKUPPLUNGEN - SISTEMA HIDRAULICO DE EMBRAGUES DE DIRECCION

1 D2.23 1
N.T.R. 191 - 20.02.1990
604.01.081.04

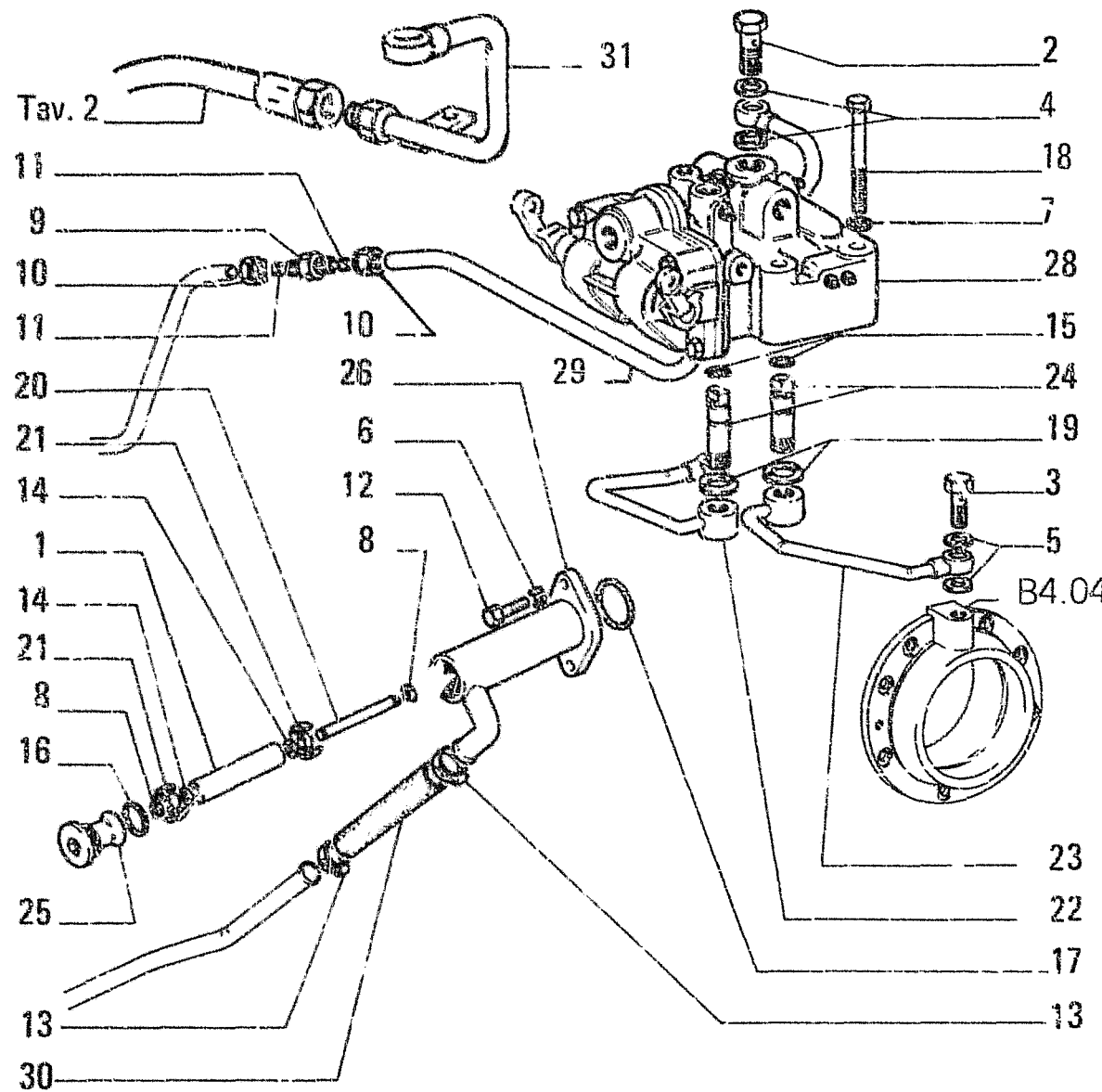

ITEM	PART NUMBER	QTY	TRANS CODE	DESCRIPTION	DESCRIZIONE
	79012341				C1519
	79044948	1	193T	TUBE - RIGHT D1519	TUBO RIGIDO - DESTRO D1519
		1	193T	TUBE - RIGHT C2939	TUBO RIGIDO - DESTRO C2939
	79099399	1	193T	TUBE - RIGHT D2939	TUBO RIGIDO - DESTRO D2939
	79012344	1	193T	TUBE - LEFT C1519	TUBO RIGIDO - SINISTRO C1519
	79044950	1	193T	TUBE - LEFT D1519	TUBO RIGIDO - SINISTRO D1519
		1	193T	TUBE - LEFT C2939	TUBO RIGIDO - SINISTRO C2939
	79099401	1	193T	TUBE - LEFT D2939	TUBO RIGIDO - SINISTRO D2939
	79012349	1	61E	END C2939	ESTREMITA' C2939
	79094062	2	61E	END D2939	ESTREMITA' D2939
	79016503	1	50T	PLUG	TAPPO
	79016511	1	254C	CONTAINER	CONTENITORE
	79028288	1	83D	CONTROL VALVE - ASSEMBLY SEE SGR. D2.29 C2939	DISTRIBUTORE - COMPLETO VEDERE SGR. D2.29 C2939
	79099767	1	83D	CONTROL VALVE - ASSEMBLY SEE SGR. D2.29 D2939	DISTRIBUTORE - COMPLETO VEDERE SGR. D2.29 D2939
	79027304	1	193T	TUBE - REAR C1519	TUBO RIGIDO - POSTERIORE C1519
	79044954	1	193T	TUBE - REAR D1519	TUBO RIGIDO - POSTERIORE D1519

STEERING CLUTCHES HYDRAULIC CONTROL - COMANDO IDRAULICO FRIZIONI DI STERZO - COMMAN-
 DE HYDRAULIQUE DES EMBRAYAGES DE DIRECTION - HYDRAUL. STEUERUNG DER LENKREIBKUPPLUN-
 GEN - SISTEMA HIDRAULICO DE EMBRAGUES DE DIRECCION

D2.23 1
 N.T.R. 191 - 20.02.1990
 604.01.031.04

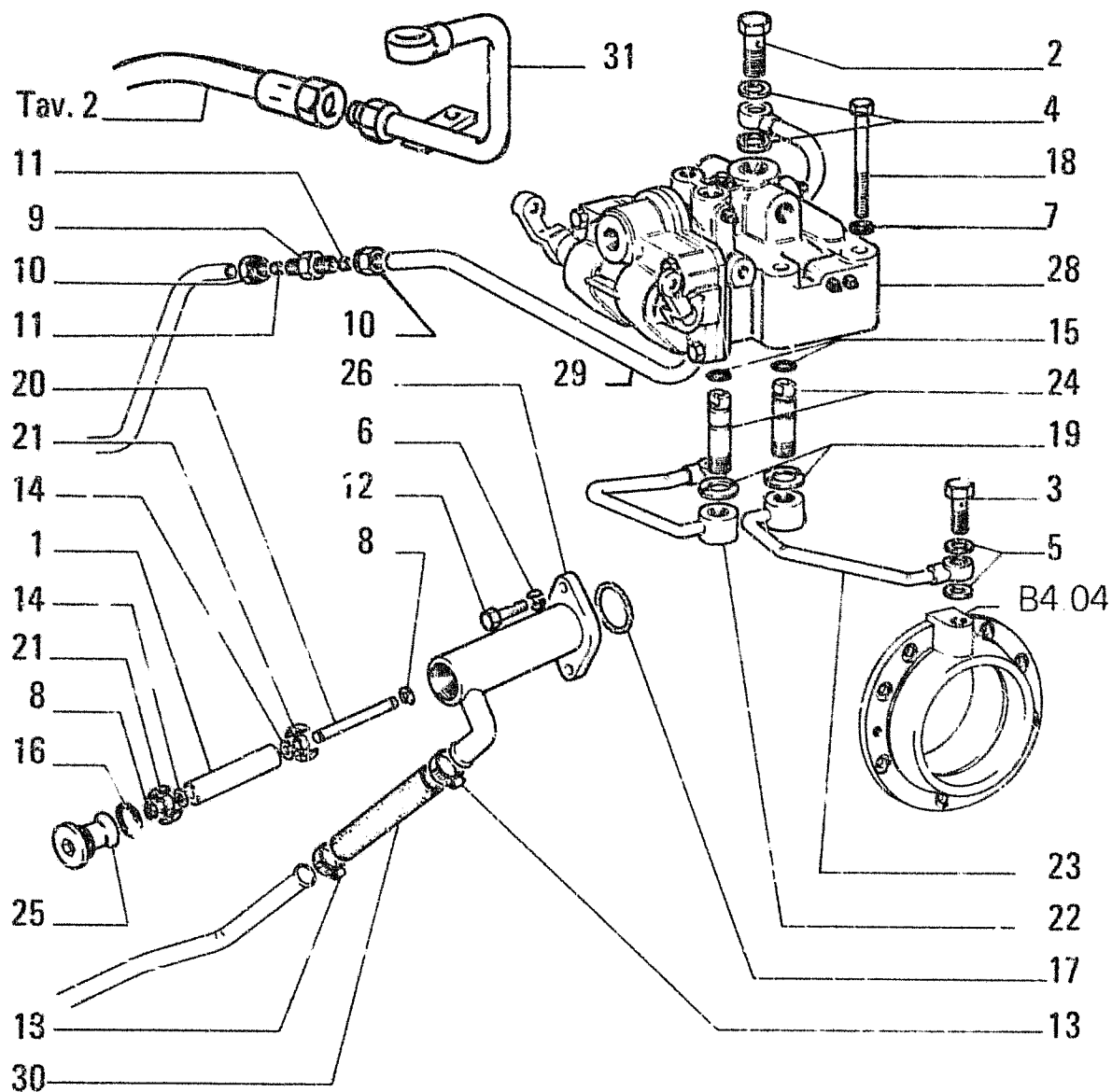

FIATALLIS FD7

ITEM	PART NUMBER	QTY	TRANS CODE	DESCRIPTION	DESCRIZIONE
29	79044954	1	192T	TUBE - REAR C1520	TUBO RIGIDO - POSTERIORE C1520
30	76015371	L	285T	HOSE 0,340M D2906	TUBO FLESSIBILE 0,340M D2906
	79032010	1	30M	SLEEV C2906	MANICOTTO C2906
31	79052025	1	193T	TUBE - REAR D1520	TUBO RIGIDO - POSTERIORE D1520

STEERING CLUTCHES HYDRAULIC CONTROL - COMANDO IDRAULICO FRIZIONI DI STERZO - COMMANDE HYDRAULIQUE DES EMBRAYAGES DE DIRECTION - HYDRAUL. STEUERUNG DER LENKREIBKUPPLUNGEN - SISTEMA HIDRAULICO DE EMBRAGUES DE DIRECCION

1	D2.23	1
N.T.R. 191 - 20.02.1990		
604.01.081.04		

DESIGNAZIONE BASE	BASIC DESIGNATION	DESIGNATIONS-BASES	GRUNDBEZEICHNUNGEN	DENOMINACIONES BASE
159C	CILINDRO FRENO	DRAKE CYLINDER	CYLINDRE DE FREIN	CILINDRO DE FRENO
159G	GUARNIZIONE LIQUIDA	GASKET LIQUID	PRODUIT LIQUID POUR ETANCHE	SELLADOR
159R	RUOTA DENTATA	GEAR WHEEL	BARBOTIN	RUEDA MOTRIZ
159S	SILENZIATORE SUPPLEMENTARE	AUXILIARY SILENCER	SILENCIEUX SUPPLEMENTAIRE	SILENCIADOR SUPLEMENTARIO
159S			FTOPF	
160C	CHIOCCIOLA	LEAD NUT	ECROU EN CARACOLE	TUERCA
160G	GRANULATO FERROSO	FERROUS GRANULATE	GRANULE FERROGINEUX	GRANULADO DE HIERRO
160R	RUOTA	WHEEL	ROUE	RUEDA
160S	SILENZIATORE	MUFFLER	SILENCIEUX	SILENCIADOR
160T	TRASMETTITORE	SENDING UNIT	TRANSMETTEUR	CONTACTOR
160S	ATTREZZO SCRAPER	SCRAPER IMPLEMENT	EQUIPEMENT RACLOIR	
161C	CILINDRO, CLASSE	CYLINDER, CLASS...	CYLINDRE, CLASSE...	CILINDRO, CLASSE...
161G	GRASSO	GREASE	GRAISSE	
161P	POMPA IDRAULICA	HYDRAULIC PUMP	POMPE HYDRAULIQUE	BOMBA HIDRAULICA
161R	RUOTA LIBERA	FREE WHEEL	ROUE LIBRE	RUEDA LIBRE
161S	SINCRONIZZATORE	SYNCHRONIZER	SYNCHRONISEUR	SINCRONIZADOR
162C	CILINDRO PNEUMATICO	AIR CYLINDER	CYLINDRE PNEUMATIQ	CILINDRO PNEUMATICO
162C			HD-PUMPE	
163C	CILINDRETTO	BARREL	CYLINDRE	CILINDRO
163R	RUOTA MOTRICE	SPROCKET	BARBOTIN MOTEUR	RUEDA MOTRIZ
164C	CILINDRO	CYLINDER	CYLINDRE	CILINDRO
164P	POMPA SERVOCOMANDO	SERVO CONTROL PUMP	POMPE DE SERVO-COMMANDE	BOMBA DE SERVOMANDO
164P			AMORTISSEUR	
164S	SMORZATORE	DAMPER		ANTIVIBRADOR
164S			SCHWINGUNGS-DAEMPFER	
165P	PONTE	AXLE	FONT	PUNTE
165R	RUTTORE	BREAKER	RUPTEUR	RUPTOR
165S	SNODO	ARTICULATION	ARTICULATION	ARTICULACION
165T	TRASMISSIONE FLESSIBILE	FLEXIBLE SHAFT	TRANSMISSION FLEXIBLE	ARBOL FLEXIBLE
166C	CILINDRO DI COMANDO CANASCI	WHEEL CYLINDER	CYLINDRE DE ROUE	CILINDRO DE FRENO
166R	RUOTA TENDICINGOLO	TRACK IDLER	ROUE TENDEUSE	RUEDA DE GUIA
166S	SOFFIETTO	BELLOWS	SOUFFLEUR	FUELLE
166T	TRECCIA DI MASSA	GROUND BRAID	TRESSE DE MASSE	TRENZA DE MASA
167C	CILINDRO DEL SERVOSTERZO	SERVO-ASSYSTED STEERING CYLINDER	CYLINDRE RECEPTEUR	CILINDRO DE SERVODIRECCION
167R	RADIATORE ACQUA	WATER RADIATOR	RADIATOR A L'EAU	RADIADOR DE AGUA
167S	SOLLEVATORE IDRAULICO	HYDRAULIC LIFTER	RELEVAGE HYDRAULIQUE	LEVANTE HIDRAULICO
167T	TRASPARENTE DELLO STOP	STOPLAMP LENS	TRANSPARENT DE FEUX STOP	TAPA TRANSLUCIDA DE LUCES DE PARE
167T			RADIATOR A HUILE	
168R	RADIATORE OLIO	OIL RADIATOR		RADIADOR DE ACEITE

DESIGNAZIONE BASE	BASIC DESIGNATION	DESIGNATIONS-BASES	GRUNDBEZEICHNUNGEN	DENOMINACIONES BASE
150C	CHIAVE	KEY	CLE	LLAVE
150G	GUIDA DELLA VALVOLA	VALVE GUIDE	GUIDE-SOUPAPE	GUIA DE VALVULA
150P	POMELLO	KNOB	BOUTON	BOTON
150R	RUSINETTO	COCK	ROBINET	GRIFO
150S	SIGLA	TRADE MARK	SIGLE	SIGLA
150T	TIMER	TIMER	TIMER	TIMER
1501	BARRA PORTATTHEZZI	TOOL BAR	BARRE PORTEOUTIL	
151B	BARRA	BAR	BARRE	BARRA
151C	CHIAVE A TUBO	PIPE WRENCH	CLE A TUBE	LLAVE DE TUBO
151G	GUIDA DELLA VALVOLA DI ASPIRAZIONE	INTAKE VALVE GUIDE	GUIDE DE SOUPAPE D'ADMISSION	GUIA DE LA VALVULA DE ADMISION
151F	POMELLO DI FISSAGGIO	RETAINING KNOB	POMMEAU DE FIXATION	POMO DE FIJACION
151E	SIGLA TRATTORE	TYPE PLATE	TYPE	SIGLA TRACTOR
152B	BENNA DA CAVA	QUARRY BUCKET	GODET DE CARRIERE	CUCHARA PARA CANTERA
152G	GUIDA DELLA VALVOLA DI SCARICO	EXHAUST VALVE GUIDE	GUIDE DE SOUPAPE D'ECAPPEMENT	GUIA DE LA VALVULA DE ESCAPE
152P	POMPA ACQUA	WATER PUMP	POMPE A EAU	BOMBA DE AGUA
153B	BENNA MORDENTE	CLAMSHELL BUCKET	BENNE PRENEUSE	CUCHARA MORDIENTE
153G	GUIDA DI SCORRIMENTO	SLIDE GUIDE	COULISSE	GUIA DESLIZANTE
153P	POMPA OLIO	OIL PUMP	POMPE A HUILE	BOMBA DE ACEITE
154C	CHIAVE SERRATURA	LOCK KEY	CLE DE SERRURE	LLAVE DE CERRADURA
154P	POMPA ALIMENTAZIONE	FUEL PUMP	POMPE D'ALIMENTATION	BOMBA DE ALIMENTACION
155B	BENNA DA ROCCIA	ROCK BUCKET	GODET DE ROCHE	CUCHARA PARA ROCAS
155G	GIUNTO RAPIDO	QUICK-CONNECTING COUPLING	ACCOUPEMENT RAPID	JUNTA RAPIDA
155P	POMPA	PUMP	POMPE	BOMBA
155R	ROLLINO	NEEDLE ROLLER	AIGUILLE	RODILLITO
155S	SILENBLOC	SILENBLOC	SILENBLOC	SILENBLOC
156B	BENNA TRAPEZOIDALE	TRAPEZOIDAL BUCKET	GODET TRAPEZE	CUCHARA TRAPEZOIDAL
156G	GOLFARE	EYEBOLT	Oeil	ARGOLLA
156P	POMPA A MANO	HAND PUMP	POMPE A MAIN	BOMBA DE MANO
157B	BENNA 4 IN 1	4-IN-1 BUCKET	GODET MULTIPLES	CUCHARA MULTI-USO
157G	GUARNIZIONE ALBERO ROTANTE	LIP SEAL	GARNITURE D'ETANCHEITE	JUNTA
157P	POMPA ARIA	AIR PUMP	POMPE A AIR	BOMBA DE AIRE
157R	RUOLO	ROLLER	GALET	RODILLO
158B	BUSTA	ENVELOPE	ENVELOPPE	SOBRE
158C	LINGUETTA A DISCO	WOODRUFF KEY	CLAVETTE	CHAVETA
158G	GUARNIZIONE O-R	O-RING	O-RING	GUARNICION TORICA
158P	POMPA INIEZIONE	INJECTION PUMP	POMPE D'INJECTION	BOMBA DE INYECCION
158T	TRASFORMATORE	TRANSFORMER	TRANSFORMATEUR	TRANSFORMADOR

DESIGNAZIONE BASE	BASIC DESIGNATION	DESIGNATIONS-BASES	GRUNDBEZEICHNUNGEN	DENOMINACIONES BASE	
140C	CERNIERA	HINGE	CHARNIERE	SCHARNIER	BISAGRA
140G	GUAINA FLESSIBILE	SHEATH	GAINÉ	HUELLE	FUNDA
140P	PLANCIA	PLANK	PLANCHE	WAND	TABLERO
140S	SFERA	BALL	BILLE	KUGEL	ESFERA
140I	LAMA ABBATTIMENTO		LAME ABATTAGE	RAMMSCHILD	
141M	MASTICE ADESIVO	PUTTY	MASTIC ADHESIF	DICHTUNGSMASSE	ALMACIGA ADHESIVA
141P	PLANCIA PORTASTRUMENTI	INSTRUMENT PANEL	TABEAU DE BORD	INSTRUMENTENBRETT	CUADRO INSTRUMENTACION
141T	TIRANTE FILETTATO	THREADED TIEROD	TIRANT	SPANNBOLZEN	PERNO
142G	GUAINA	SHEATH	GAINÉ	SCHUTZROHR	FUNDA
142M	MOLLA A BALESTRA	LEAF SPRING	ROSSORT A LAMES	BLATTFEDER	MUELLE DE BALLESTA
142T	TIRANTE	TIEROD	TIRANT	STANGE	TIRANTE
142I	LAMA CAVACIPPI		LAME DESOUCHÉSE	STUBBENRODER	
143M	MOTOASSALE	LIVE AXLE	ESSIEU MOTEUR	ACHSANTRIEB	EJE
143T	TIRANTE DI STERZO TRASVERSALE	TRACK ROD	BARRE D'ACCOUPLE- MENT	SPURSTANGE	BARRA DE ACUPLA- MIENTO
143T			LAME EPIERREUSE	FELSRÉCHEN	
143I	LAMA SPIETRA RICE		MANIPULATEUR	DRUCK FERNSTEUERUNG	
144M	MANIPOLATORE	MANIPULATOR	BARRE DE DIRECTION	LENKSTANGE	BARRA DE DIRECCION
144T	TIRANTE DI STERZO LONGITUDINA- LE	DRAG LINK			
1440	LAMA DECESPUGLIATRICE PER AD		LAME DEBROUSSAILLEUSE AD	RODERÉCHEN (AD)	
1441	LAMA DECESPUGLIATRICE PER SD		LAME DEBROUSSAILLEUSE SD	RODERÉCHEN (SD)	
145B	BUSSOLA	GUIDE BUSHING	DOUILLE	GEWINDEBUECHSE	CASQUILLO
145G	GUIDA	GUIDE	GUIDE	FUEHRUNG	GUIA
145M	MAGLIA CINCOLO	TRACK LINK	MAILLON	KETTENGLIED	MALLA DE ORUGA
145P	PLANETARIO	SUN GEAR	PLANETAIRE	PLANETENANTRIEB	PINON PLANETARIO
145R	ROTORE	ROTOR	ROTOR	LAUFER	ROTOR
145S	SFIATATOIO	BREATHER	RENIFLARD	ENTLUEFTER	RESPIRADERO
146M	MODULO ANTERIORE	TOOL MODULE	MODULE ANTERIEUR		MODULO ANTERIOR
146R	ROTULA SFERICA	BALL JOINT	ROTULE	KUGELBUECHSE	ROTULA
146T	TIRANTE ELASTICO	ELASTIC TIEROD	TIRANT ELASTIQUE	FEDERENDE STANGE	VARILLA ELASTICA
147G	GUIDA DELLA MOLLA	SPRING GUIDE	GUIDE-RESSORT	FEDERFUEHRUNG	GUIA DE RESORTE
147M	MODULO POSTERIORE	POWER MODULE	MODULE POSTERIEUR		MODULO POSTERIOR
147P	PNEUMATICO	TIRE	PNEU	REIFEN	NEUMATICO
147T	TORRETTA	TURRET	TOURTELLE	OBERWAGEN	TORRE
148P	POLVERIZZATORE	NOZZLE	PULVERISATEUR	EINSPRITZDÜSE	PULVERIZADOR
148S	SI FORNISCONO SOLO LE PARTI	ONLY SEPARATE PARTS ARE SERVED	ON LIVRE SEULEMENT SES PIÉCES	NUR EINZELTEILE LIEFERBAR	SOLO SE SUMINIS- TRAN LAS PIEZAS SUeltas
148S					
148S					
149R	RUBINETTO-VALVOLA	COCK VALVE	ROBINET	VENTIL	VALVULA
150B	BORSA	BAG	TROUSSE	TASCHE	BOLSA

D

FRAME • STEERING • SUSPENSIONS • WHEELS • UNDERCARRIAGE • HYDRAULIC TRANSMISSION
TELAIO • STERZO • SOSPENSIONI • RUOTE • CINGOLATURA • TRASMISSIONE IDRAULICA
CADRE • DIRECTION • SUSPENSIONS • ROUES • TRAIN DE FOULEMENT • TRANSMISSION HYDRAULIQUE
RAHMEN • LENKUNG • AUFHÄNGUNGEN • RÄDER • KETTENLAUFWERK • HYDRAULISCHER ANTRIEB
BASTIDOR • DIRECCIÓN • SUSPENSIÓN • RUEDAS • TREN DE RODAJE • TRANSMISIÓN HIDRÁULICA

M1

FIAT ALLIS F37

D3.347AV. 1 PAG.1

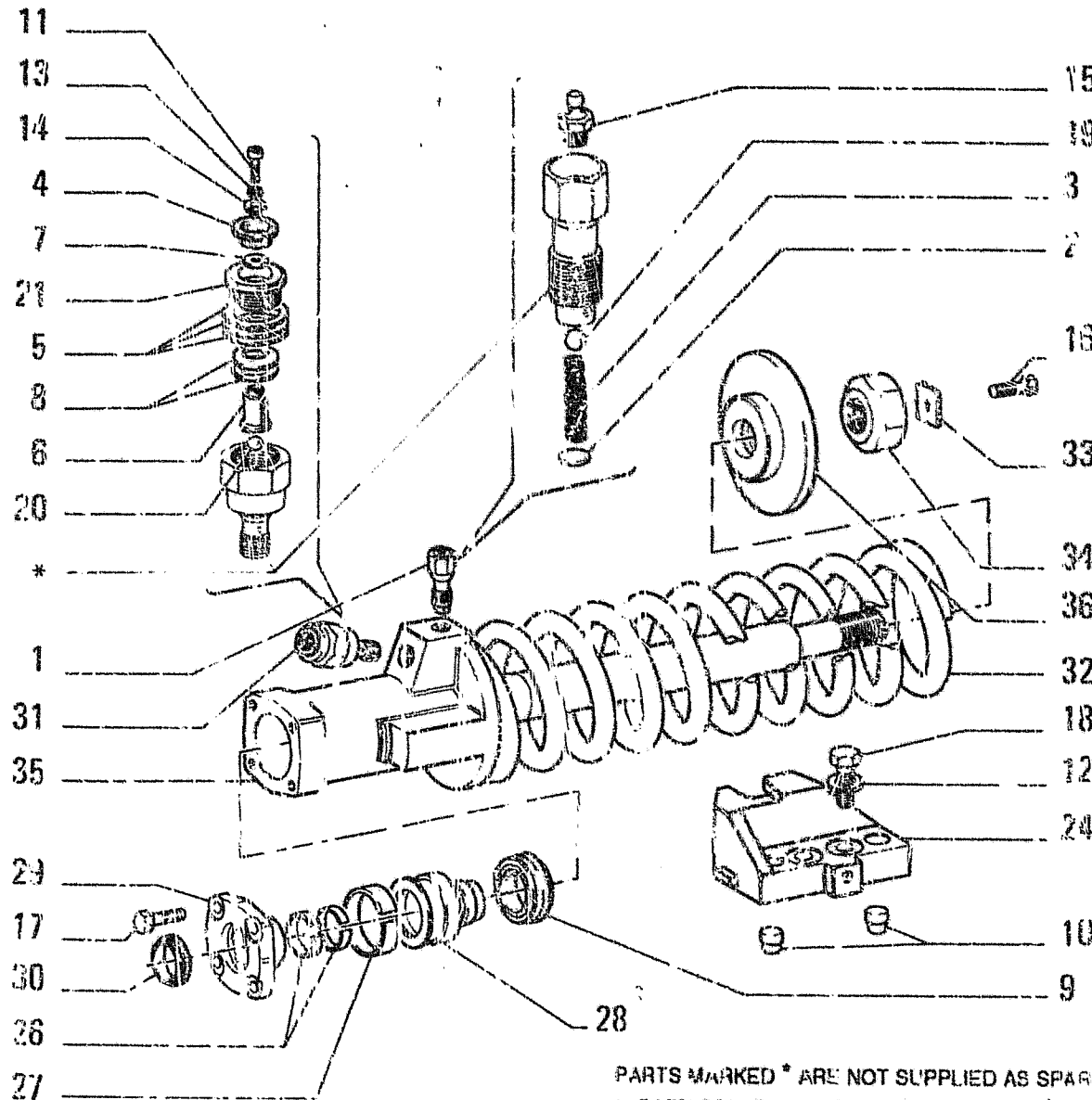

QTY	PART NUMBER	TRANS CODE	DESCRIPTION	DESCRIZIONE
2	587271	10V	VALVE - ASSEMBLY C1170	VALVOLA - COMPLETO C1170
2	79043802	10V	VALVE - ASSEMBLY D1170	VALVOLA - COMPLETO D1170
2	587272	131R	WASHER	ROSETTA
2	587273	100M	SPRING	MOLLA
2	594639	70R	GUARD	RIPARO
2	594634	131R	WASHER	ROSETTA
2	594637	9V	SAFETY VALVE	VALVOLA SICUREZZA
16	594638	100M	SPRING	MOLLA
110P	594640		PLAQUE 0,1	PIASTRINA 0,1
110P	79009581		PLAQUE 0,2	PIASTRINA 0,2
110P	79009582		PLAQUE 0,5	PIASTRINA 0,5
2	59609E	158G	O-RING	GUARNIZIONE O-R
8	4955005	90G	DOWEL	GRANCO
2	10389511	40V	SCREW 5x0,8x14	VITE 5x0,8x14
8	10517271	132R	LOCKWASHER 16,2x4	ROSETTA DI SICUREZZA 16,2x4
2	11195471	132R	LOCKWASHER 5,1x1,1	ROSETTA DI SICUREZZA 5,1x1,1
2	12636101	131R	WASHER 5,15x14	ROSETTA 5,15x14
2	13407211	60I	GREASE FITTING 10x1	INGRASSATORE 10x1
2	14233030	40V	SCREW 10x1,25x16	VITE 10x1,25x16
8	14233430	40V	SCREW 10x1,25x25	VITE 10x1,25x25
8	15840537	40V	SCREW 16x1,5x50	VITE 16x1,5x50
2	20063460	140S	BALL 7,144	SFERA 7,144
2	20063470	140S	BALL 7,938	SFERA 7,938
2	79002121	265C	COVER	COPERCHIO
2	79012662	300S	SUPPORT - LEFT	SUPPORTO - SINISTRO
2	79012663	300S	SUPPORT - RIGHT	SUPPORTO - DESTRO
4	79012676	45A	RING	ANELLO

IDLER WHEEL - TENDICINGOLO - ROUE TENDEUSE - RAUPENKETTENSANNER - RUEDA GUIADORA

D3.34 1

N.T.R. 152 - 28.11.1986
604.01.081.02

M2

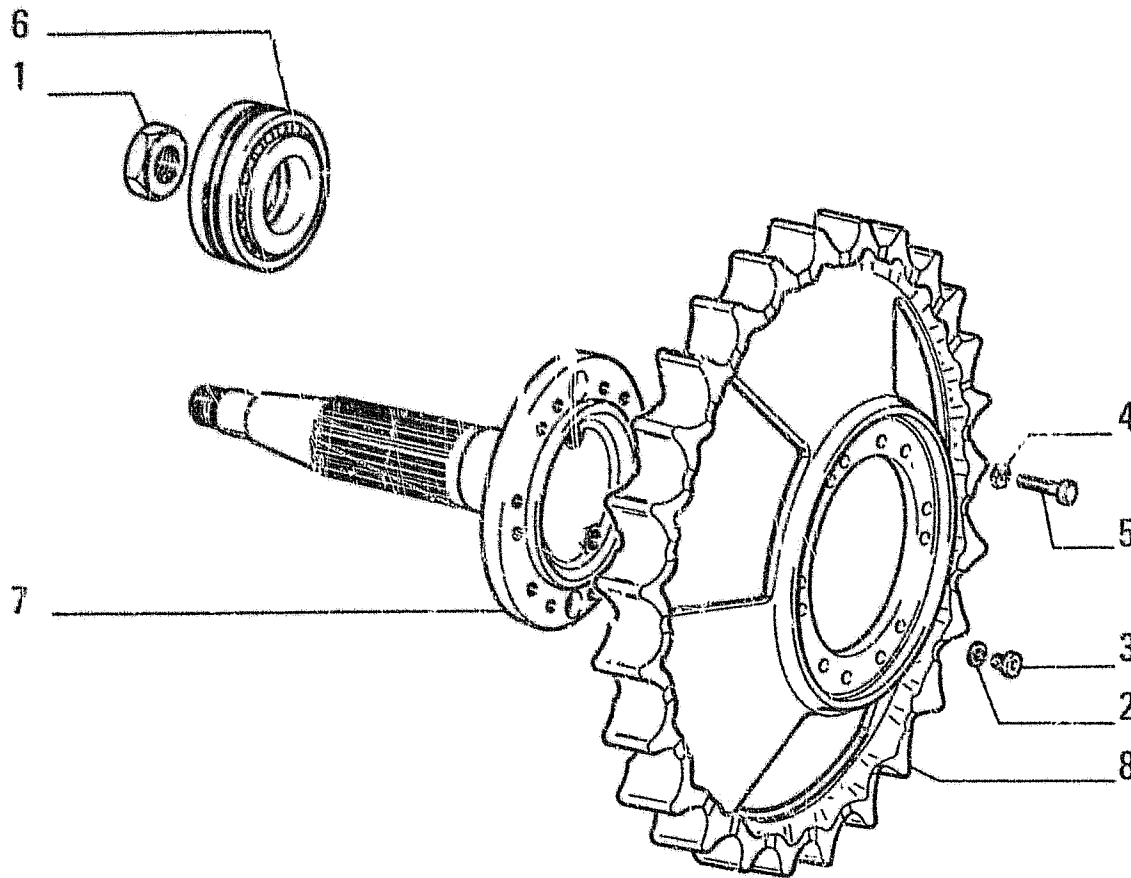

ITEM	PART NUMBER	QTY	TRANS CODE	DESCRIPTION	DESCRIZIONE
1	4965705	2	10D NUT		DADO
2	10264080	6	133F SEAL 18,2x24		ROSETTA DI TENUTA 18,2x24
3	10273111	6	50T PLUG 18x1,5x10		TAPPO 18x1,5x10
4	10517371	24	132R LOCKWASHER 18,2x4,2		ROSETTA DI SICUREZZA 18,2x4,2
5	11408537	24	40V SCREW 18x1,5x40		VITE 18x1,5x40
3	79012996	2	341C BEARING		CUSCINETTO
7	79024821	2	16A SHAFT C1579		ALBERO C1579
	79058653	2	16A SHAFT D1579		ALBERO D1579
8	79029613	2	163R SPROCKET C2879		RUOTA MOTRICE C2879
	79087039	2	163R SPROCKET D2879		RUOTA MOTRICE D2879

DRIVE SPROCKET - RUOTA MOTRICE - BORBOTIN MOTEUR - TRIEBRAD - RUEDA MOTRIZ

D3.33

N.T.R. 191 - 20.02.1990

604.01.081.04

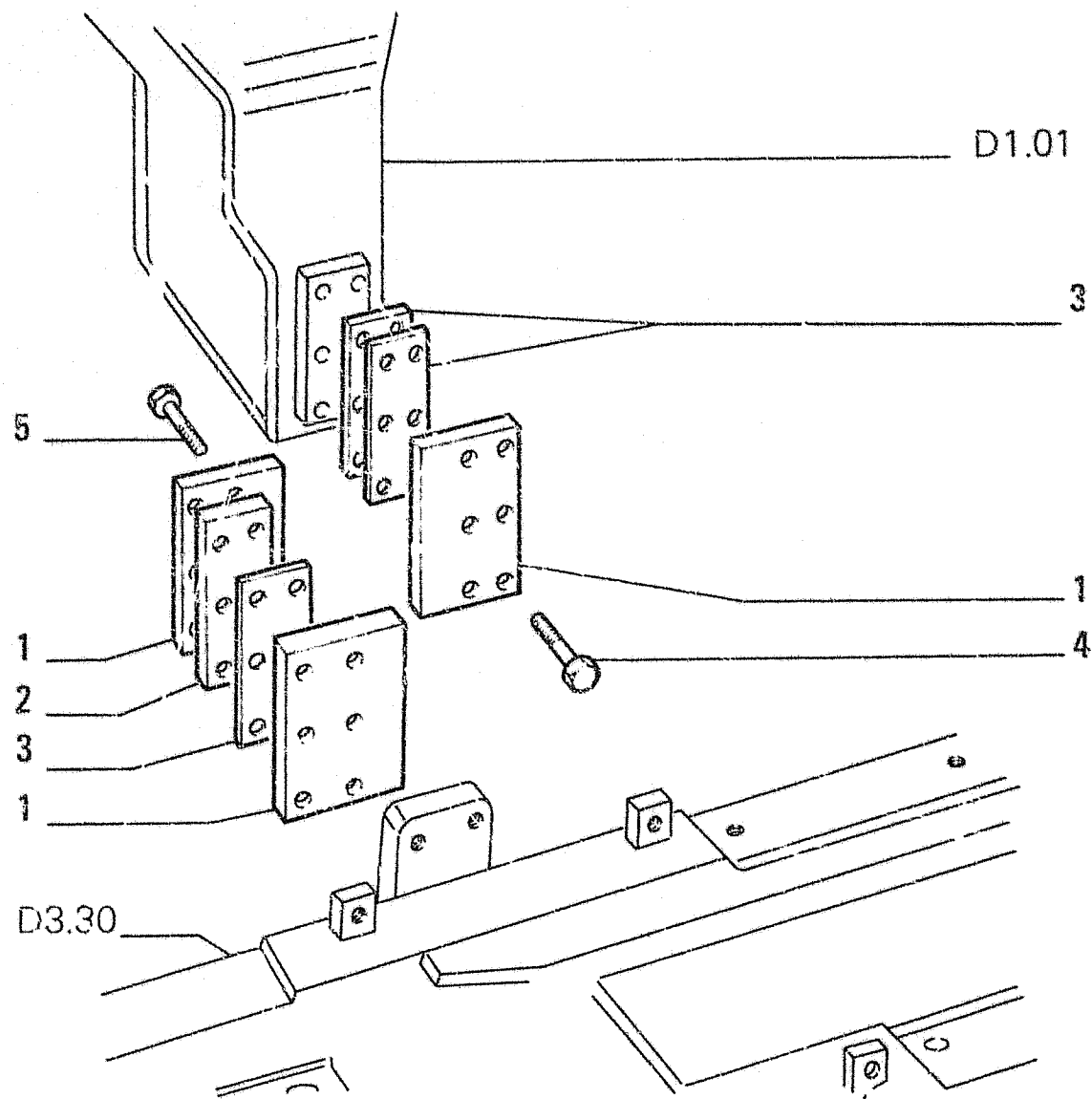

ITEM	PART NUMBER	QTY	TRANS CODE	DESCRIPTION	DESCRIZIONE
1	4971716	6	145G	GUIDE	GUIDA
2	4971717	2	75D	SPACER	DISTANZIALE
3	4971719	106S		SHIM 1,5	SPESSORE 1,5
	4971720	198S		SHIM 1	SPESSORE 1
	4971721	191S		SHIM 0,5	SPESSORE 0,5
4	14274731	12	40V	SCREW 12x1,25x40	VITE 12x1,25x40
5	14275231	12	40V	SCREW 12x1,25x65	VITE 12x1,25x65

TRACK FRAME CROSS BAR - COLLEGAMENTO CARRELLI CINGOLI - ACCOUPLEMENT DE CHARIOTS DE CHENILLES - VERBINDUNG DER RAUPENFAHRWERKRAHMEN - ENLACE DE ARMAZONES DE CADENA

D3.31

M4

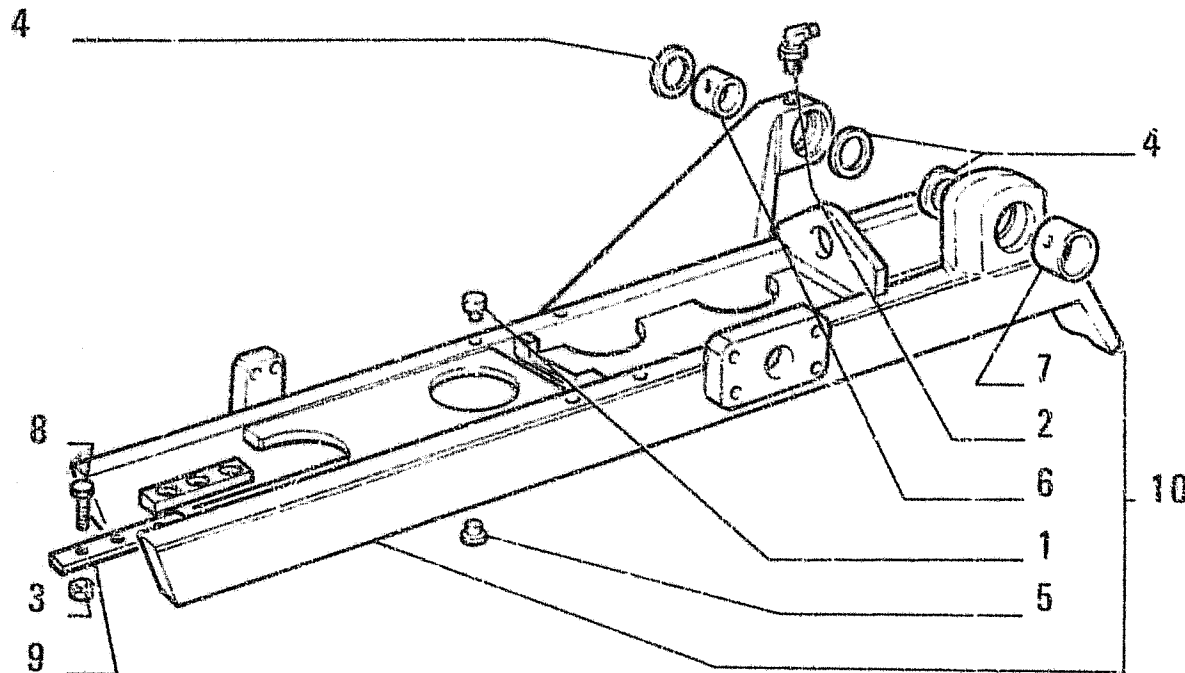

ITEM	PART NUMBER	QTY	TRANS CODE	DESCRIPTION	DESCRIZIONE
1	4955605	4	90G	DOWEL	GRANO
2	13407811	1	60I	GREASE FITTING 10x1x4,5	INGRASSATORE 10x1x4,5
3	16104121	12	10D	NUT 8x1,25x10,6	DADO 8x1,25x10,6
4	79023900	6	120G	GASKET	GUARNIZIONE PIANA
5	79024229	12	50T	PLUG	TAPPO
6	79024330	1	95B	BUSHING	BOCCOLA
7	79024331	1	95B	BUSHING	BOCCOLA
8	79033531	12	40V	SCREW	VITE
9	79033532	4	198S	SHIM	SPESSORE
10	79033648	1	300C	BODY - RIGHT ASSEMBLY	CORPO - DESTRO COMPLETO
	79033651	1	300C	BODY - LEFT ASSEMBLY	CORPO - SINISTRO COMPLETO

TRACK FRAME BODY - CORPO CARRELLO CINGOLO - CHASSIS DE CHARIOT DE CHENILLE -
 RAUPENFAHRWERKRAHMEN - ARMAZON DE CADENA -

D3.30

N.T.R. 205 - 30.09.1991
 604.01.081.06

M5

CNA

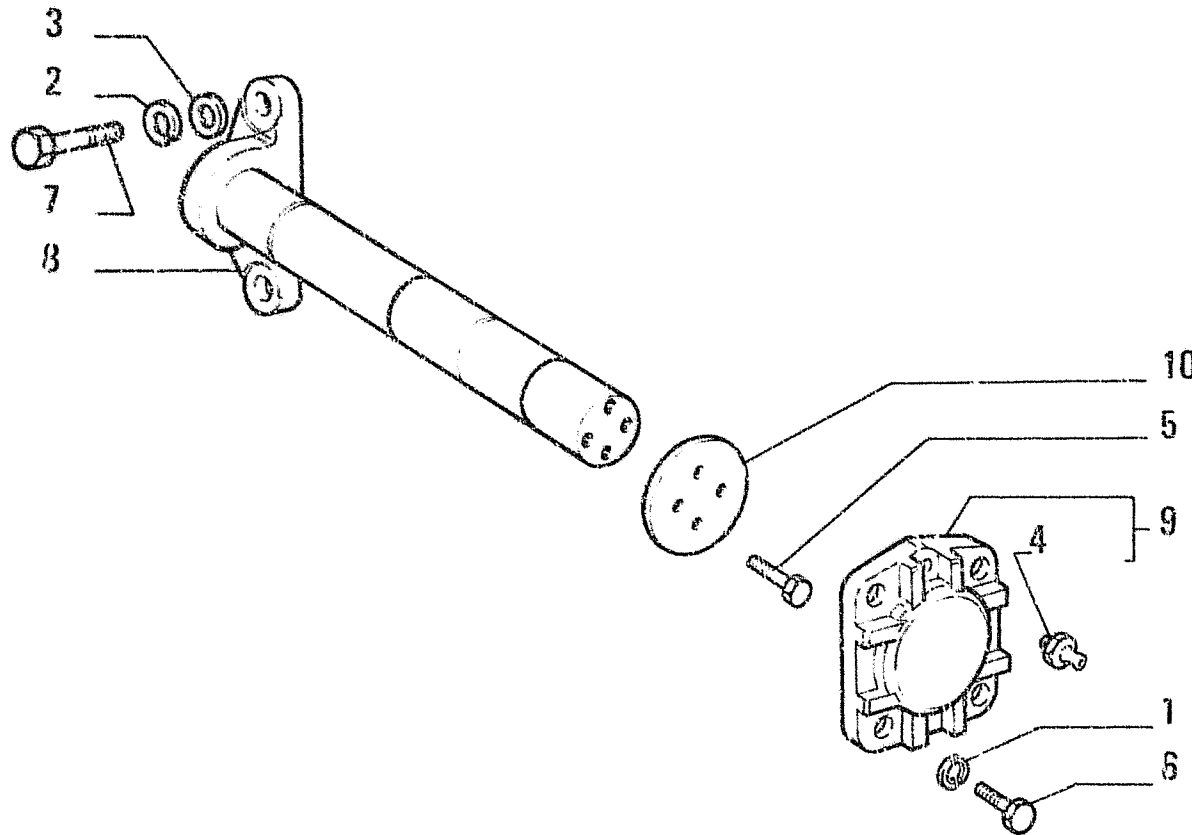

ITEM	PART NUMBER	QTY	TRANS CODE	DESCRIPTION	DESCRIZIONE
1	10517071	8	132R	LOCKWASHER 12,2x3,1	ROSETTA DI SICUREZZA 12,2x3,1
2	10517471	6	132R	LOCKWASHER 20,2x4,5	ROSETTA DI SICUREZZA 20,2x4,5
3	10520421	6	1C1R	WASHER 20,4x35	ROSETTA 20,4x35
4	13407211	2	60I	GREASE FITTING 10x1	INGRASSATORE 10x1
5	14274530	8	40V	SCREW 12x1,25x30	VITE 12x1,25x30
6	15540431	8	40V	SCREW 12x1,25x30	VITE 12x1,25x30
7	15988637	6	40V	SCREW 20x1,5x75	VITE 20x1,5x75
8	79024442	2	16A	SHAFT	ALBERO
9	79024444	2	265C	COVER - ASSEMBLY	COPERCHIO - COMPLETO
10	79024445	2	131R	WASHER	ROSETTA

REAR SUSPENSION — SOSPENSIONE POSTERIORE — SUSPENSION AR — HINTERRADAUFHAENGUNG —
SUSPENSION POSTERIOR

D3.05

N.T.R. 191 - 20.02.1990

604.01.081.04

M6

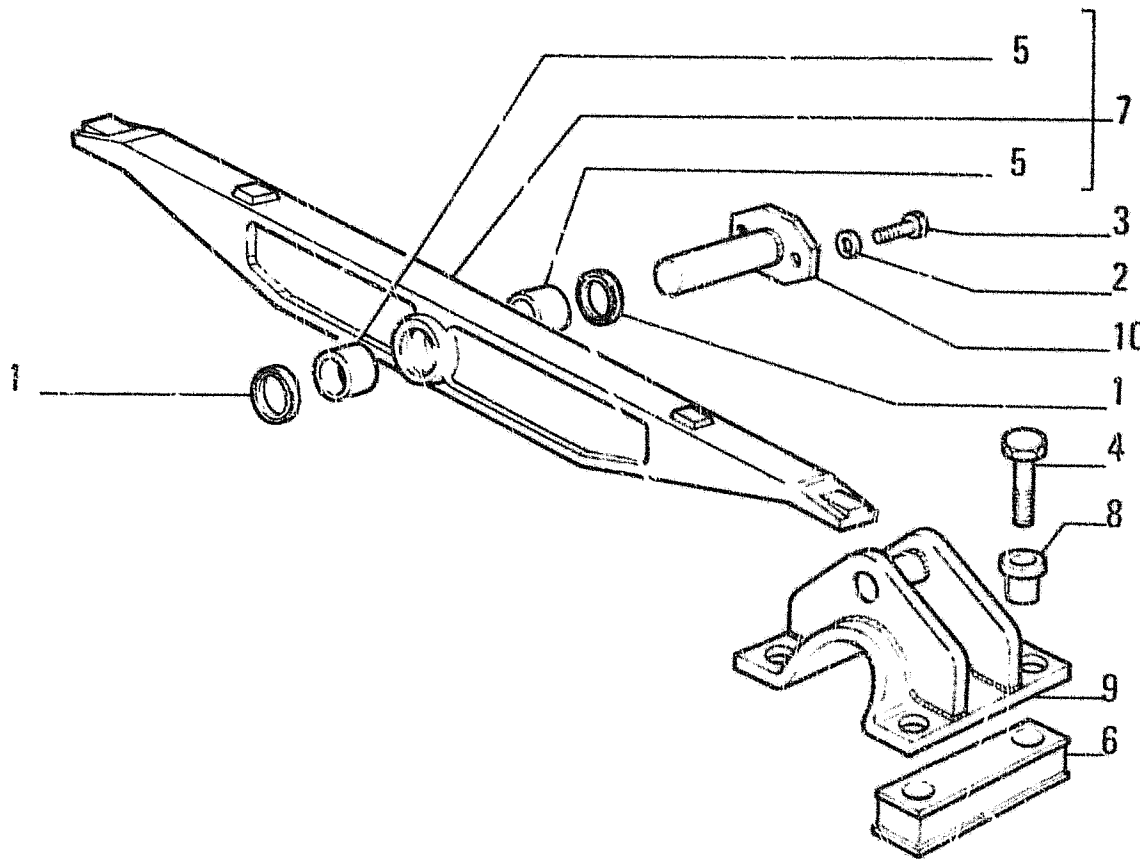

ITEM	PART NUMBER	QTY	TRANS CODE	DESCRIPTION	DESCRIZIONE
1	8288832	2	120G	GASKET	GUARNIZIONE PIANA
2	10516871	2	132R	LOCKWASHER 10x2,5	ROSETTA DI SICUREZZA 10x2,5
3	11306931	2	40V	SCREW 10x1,25x30	VITE 10x1,25x30
4	14272031	8	40V	SCREW 18x1,5x65	VITE 18x1,5x65
5	76011135	2	93B	BUSHING - IN ALTERNATIVE	BOCCOLA - IN ALTERNATIVA
	79014617	2	95B	BUSHING - IN ALTERNATIVE	BOCCOLA - IN ALTERNATIVA
6	79026708	4	60T	BLOCK	TASSELLO
7	79027031	1	180T	CROSS BEAM - ASSEMBLY	TRAVERSA - COMPLETO
8	79027034	8	95B	BUSHING	BOCCOLA
9	79027038	2	300S	SUPPORT	SUPPORTO
10	79035451	1	80P	PIN	PERNO

FRONT SUSPENSION - SOSPENSIONE ANTERIORE - SUSPENSION AV - VORDERRADAUFHAENGUNG -
 SUSPENSION ANTERIOR

D3.01

N.T.R. 158 - 13.03.1987
 604.01.081.03

M7

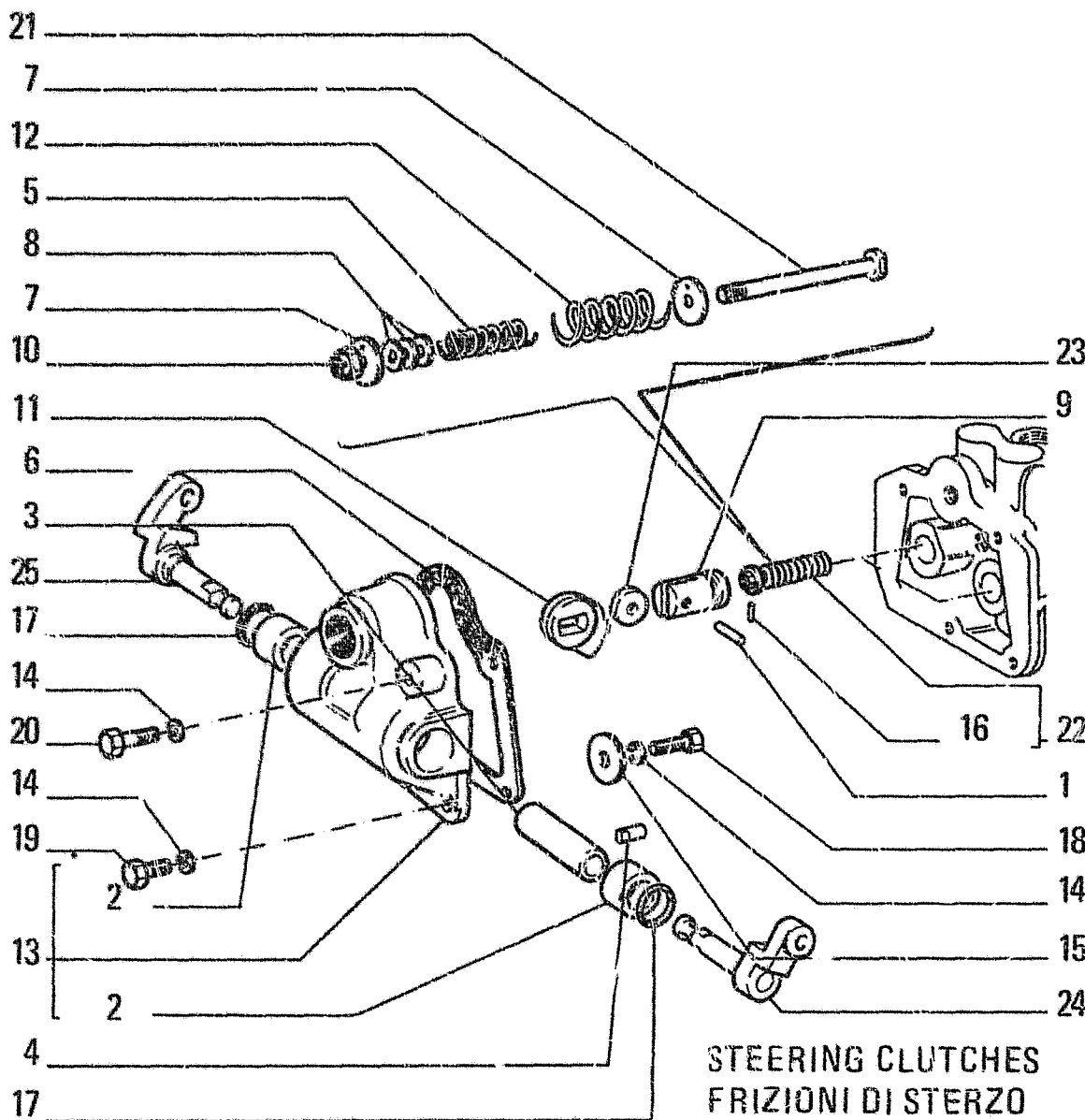

FIATALLIS FD7

D2.29 TAV. 2 PAG.1

I T E M	PART NUMBER	Q T Y	TRANS CODE	DESCRIPTION	DESCRIZIONE
1	575888	2	80P	PIN	PERNO
2	587130	2	95B	BUSHING	BOCCOLA
3	587141	1	75D	SPACER	DISTANZIALE
4	587142	2	80P	PIN	PERNO
5	591107	2	100M	SPRING - INNER	MOLLA - INTERNO
6	591115	1	122G	SEAL	GUARNIZIONE
7	591121	4	131R	WASHER	ROSETTA
8	591123		198S	SHIM	SPESSORE
9	595736	2	240P	TAPPET	PUNTERIA
10	599820	2	10D	NUT	DADO
11	591125	2	10E	ECCENTRIC	ECCENTRICO
12	79030539	2	100M	SPRING - OUTER	MOLLA - ESTERNO
13	4983643	1	265C	COVER - ASSEMBLY	COPERCHIO - COMPLETO
14	10516671	3	132R	LOCKWASHER 8,1x2,2	ROSETTA DI SICUREZZA 8,1x,2
15	12647001	1	131R	WASHER 8,15x25	ROSETTA 8,15x25
16	14157470	1	200S	PIN 1,7x10	SPINA 1,7x10
17	14457280	2	158G	O-RING 2,62x15,54	GUARNIZIONE O-R 2,62x15,54
18	16043131	1	40V	SCREW 8x1,25x14	VITE 8x1,25x14
19	16043431	3	40V	SCREW 8x1,25x20	VITE 8x1,25x20
20	16043931	2	40V	SCREW 8x1,25x35	VITE 8x1,25x35
21	79003679	2	80P	PIN	PERNO
22	79003686	2	100M	SPRING - ASSEMBLY C2939	MOLLA - COMPLETO C2939
	79030538	2	100M	SPRING - ASSEMBLY D2939	MOLLA - COMPLETO D2939
23	79004433	4	157R	ROLLER	RULLO
24	587155	1	45L	LEVER - OUTER RIGHT	LEVA - ESTERNO DESTRO
25	591217	1	45L	LEVER - OUTER LEFT	LEVA - ESTERNO SINISTRO

79028288-79099767

CONTROL VALVE - DISTRIBUTORE - DISTRIBUTEUR -- STEUERGERAET - DISTRIBUIDOR

D2.29

2

N.T.R. 200 - 15.10.1990

804.01.001.05

M8

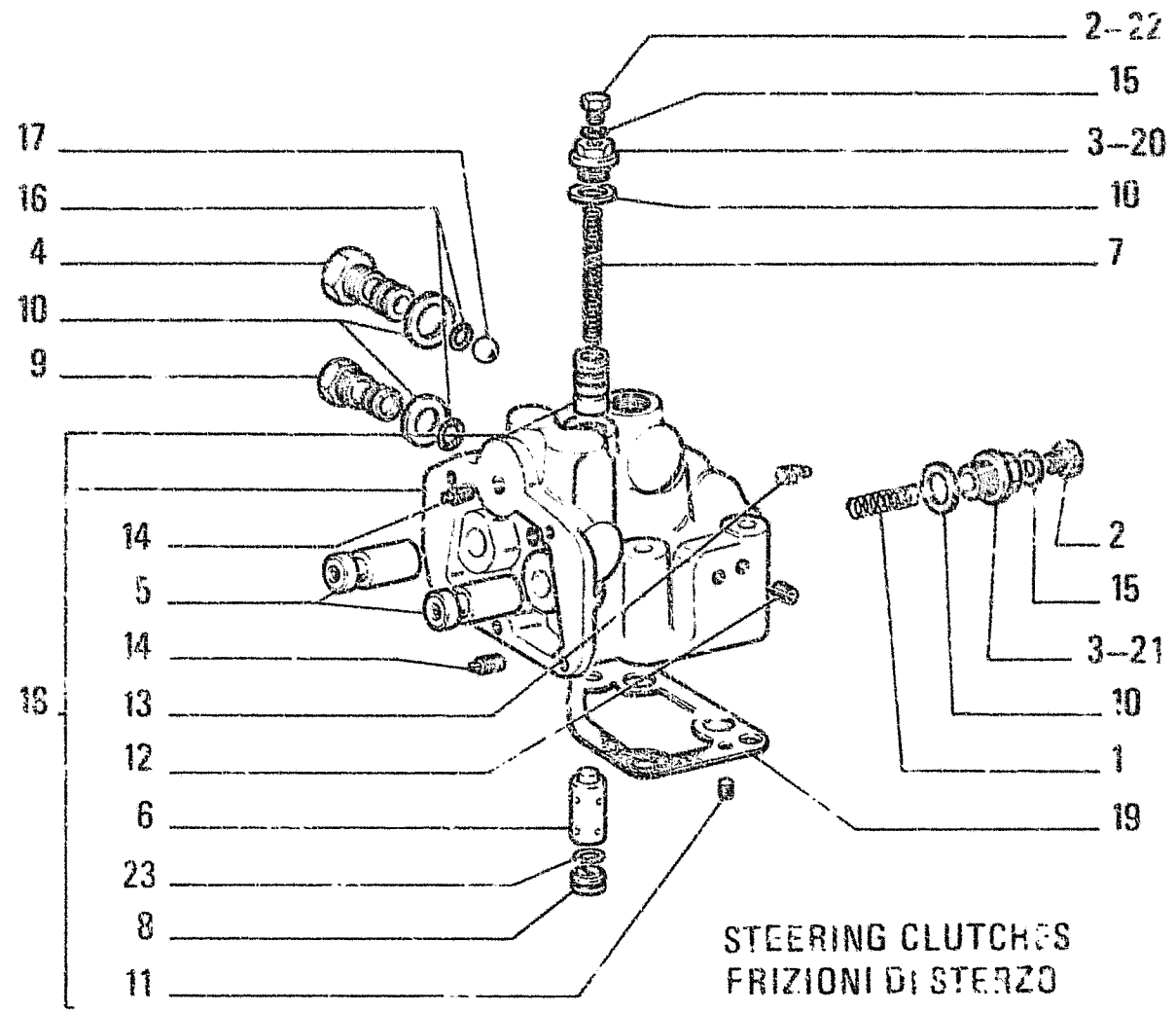

ITEM	PART NUMBER	QTY	TRANS CODE	DESCRIPTION	DESCRIZIONE
22	10300571	1	50T	PLUG 12x1,5x8 Ø2939	TAPPO 12x1,5x8 Ø2939
23	14456980	1	158G	O-RING 2,62x10,77	GUARNIZIONE O-R 2,62x10,77

STEERING CLUTCHES
FRIZIONI DI STERZO

79028288-79099767
CONTROL VALVE - DISTRIBUTORE - DISTRIBUTEUR - STEUERGERAET - DISTRIBUIDOR

D2.29 1
N.T.R. 200 - 15.10.1990
604.01.081.06

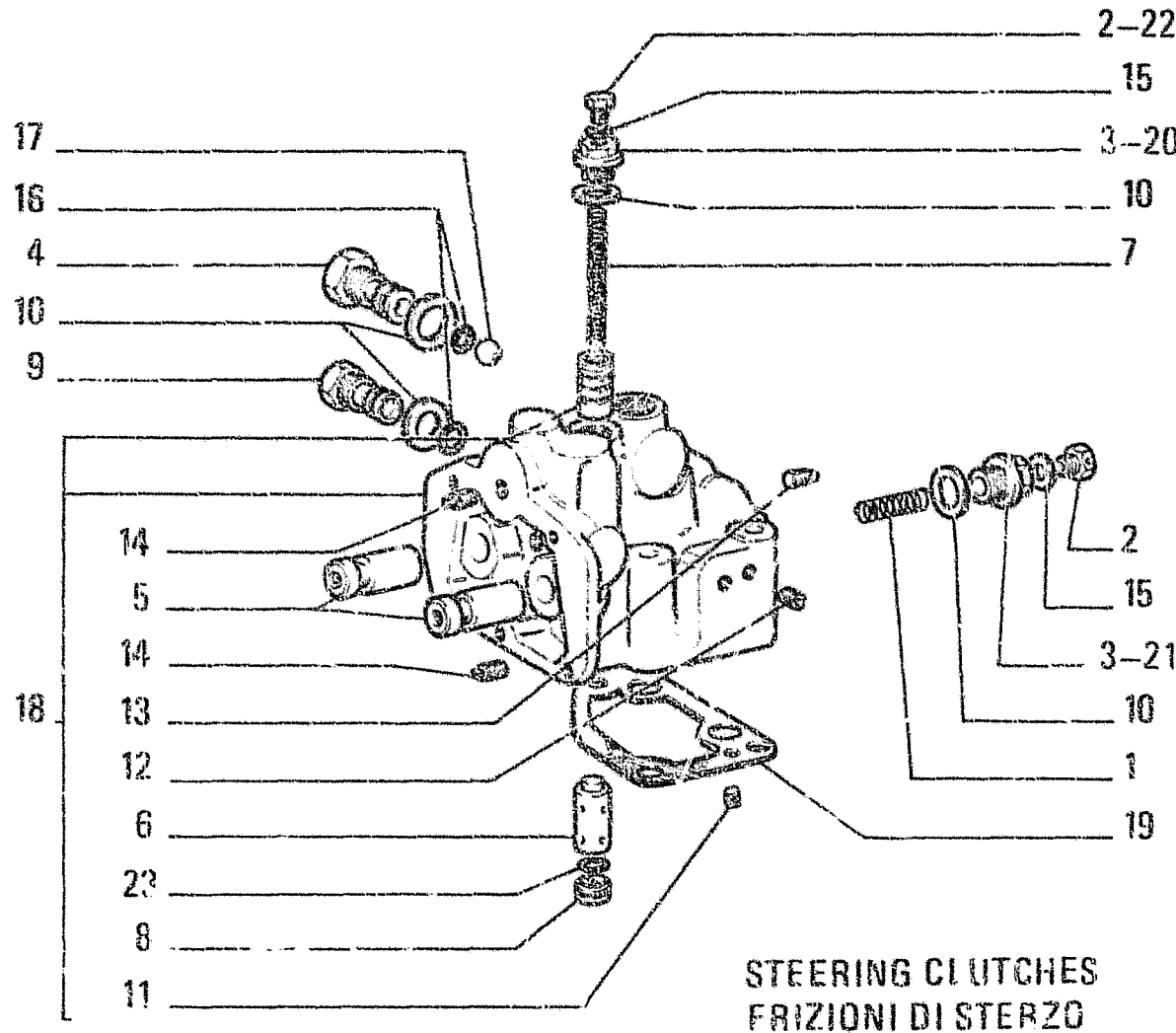

ITEM	PART NUMBER	QTY	TRANS CODE	DESCRIPTION	DESCRIZIONE
1	575874	2	100M	SPRING	MOLLA
2	581658	2	50T	PLUG	TAPPO
		1	50T	PLUG C2939	TAPPO C2939
3	581967	3	20R	FITTING C2939	RACCORDO C2939
4	587158	1	50T	PLUG	TAPPO
5	591105	2	75F	CARRIER	FLOTTANTE
6	591108	1	75F	CARRIER	FLOTTANTE
7	591112	1	100M	SPRING C2939	MOLLA C2939
	79036901	1	100M	SPRING D2939	MOLLA D2939
8	591247	1	50T	PLUG - LOWER	TAPPO - INFERIORE
9	595878	1	50T	PLUG	TAPPO
10	10257460	5	133R	SEAL 20,2x26	ROSETTA DI TENUTA 20,2x26
11	10269450	1	50T	PLUG 12x1,5x11	TAPPO 12x1,5x11
12	14324811	2	50T	PLUG 12x1,5x13	TAPPO 12x1,5x13
13	14324911	2	50T	PLUG 14x1,5x13	TAPPO 14x1,5x13
14	14325011	2	50T	PLUG 16x1,5x13	TAPPO 16x1,5x13
15	10296160	3	133R	SEAL 12,2x18 C2939	ROSETTA DI TENUTA 12,2x18 C2939
	14330260	3	133R	SEAL 8,2x12 D2939	ROSETTA DI TENUTA 8,2x12 D2939
16	14456980	2	158G	O-RING 2,62x10,77	GUARNIZIONE O-R 2,62x10,77
17	20063000	1	140S	BALL 15,082	SFERA 15,082
18	79002971	1	300C	BODY - ASSEMBLY C2939	CORPO - COMPLETO C2939
	79093391	1	300C	BODY - ASSEMBLY D2939	CORPO - COMPLETO D2939
19	79007717	1	123G	SEAL ASSY	GUARNIZIONE TENUTA FRONTALE
20	79093391	1	20R	FITTING D2939	RACCORDO D2939
21	581967	2	20R	FITTING D2939	RACCORDO D2939

79028288-79099767

CONTROL VALVE - DISTRIBUTORE - DISTRIBUTEUR - STEUERGERAET - DISTRIBUIDOR

D2.29

1

N.T.R. 200 - 15.10.1990

604.01.091.05

M10

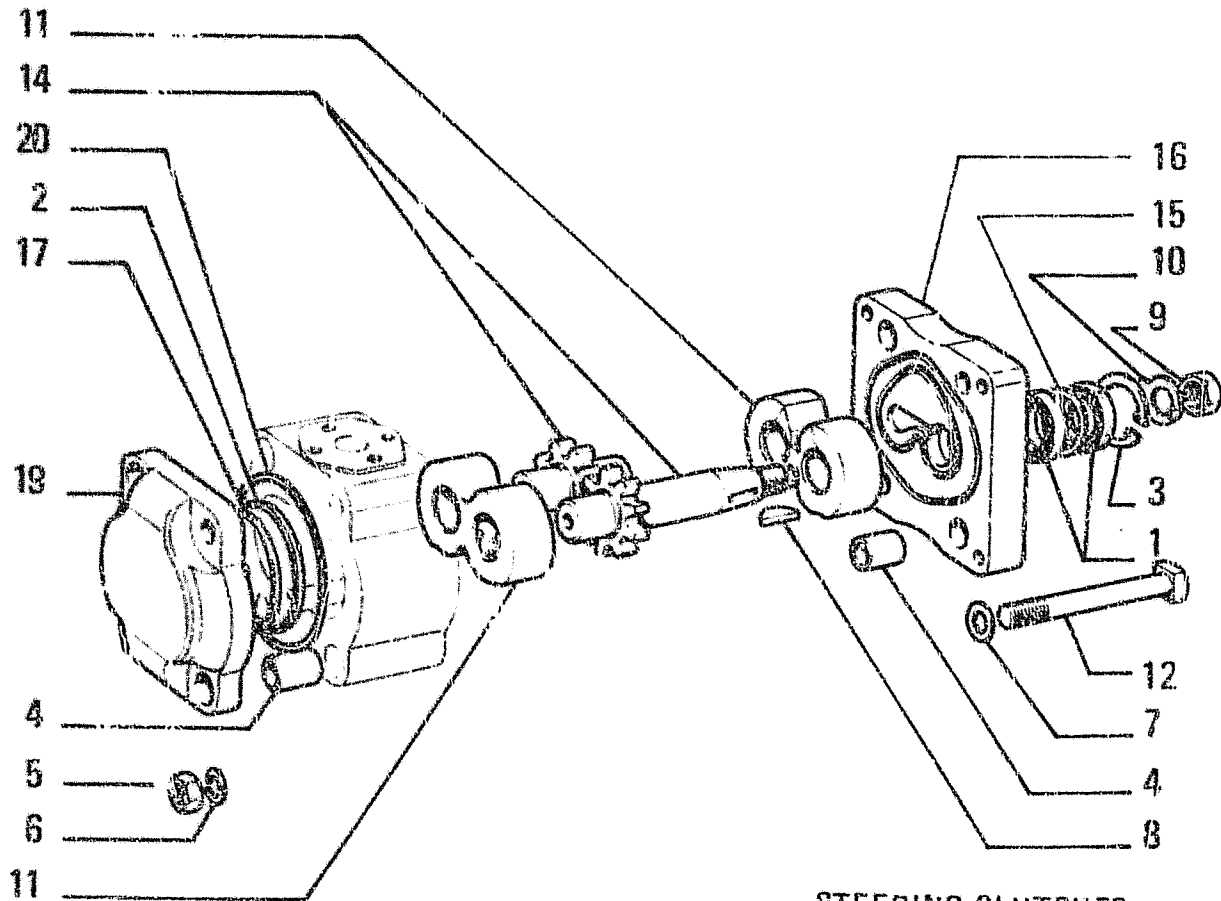

STEERING CLUTCHES
FRIZIONI DI STERZO



D1510 tel. n. 250905 →

ITEM	PART NUMBER	QTY	TRANS CODE	DESCRIPTION	DESCRIZIONE
1	5110478	2	123G	SEAL ASSY	GUARNIZIONE TENUTA FRONTALE
2	8273909	2	158G	O-RING	GUARNIZIONE O-R
3	8273911	1	187A	SNAP RING	ANELLO ELASTICO
4	5120207	4	95B	BUSHING	BOCCOLA
5	12164721	4	10D	NUT 10x1,25x8	DADO 10x1,25x8
6	10516871	4	170R	LOCKWASHER 10x2,5	ROSETTA EL. 10x2,5
7	10284460	4	131R	WASHER 10,2x16	ROSETTA 10,2x16
8	8273918	1	60L	KEY	LINGUETTA
9	8273910	1	10D	NUT	DADO
10	8273920	1	132R	LOCKWASHER	ROSETTA DI SICUREZZA
11	8273940	2	300S	SUPPORT	SUPPORTO
12	5120484	4	40V	SCREW	VITE
14	8274234	1	286C	GEAR SET	COPPIA DI INGRANAGGI
15	8280188	1	75D	SPACER	DISTANZIALE
16	5120206	1	70F	FLANGE	FLANGIA
17	8281201	2	158G	O-RING	GUARNIZIONE O-R
18	8281576	1	1K	KIT SEE PAGE 9	KIT VED. PAG.9
19	5120204	1	285C	COVER	COPERCHIO
20	14460380	2	150G	O-RING 2,62x64,77	GUARNIZIONE O-R 2,62x64,77

5120481

PUMP - POMPA - POMPE - PUMPE - BOMBA

D2.27/A

N. T. R. 191 - 20.02.1990

604.01.081.04

M11

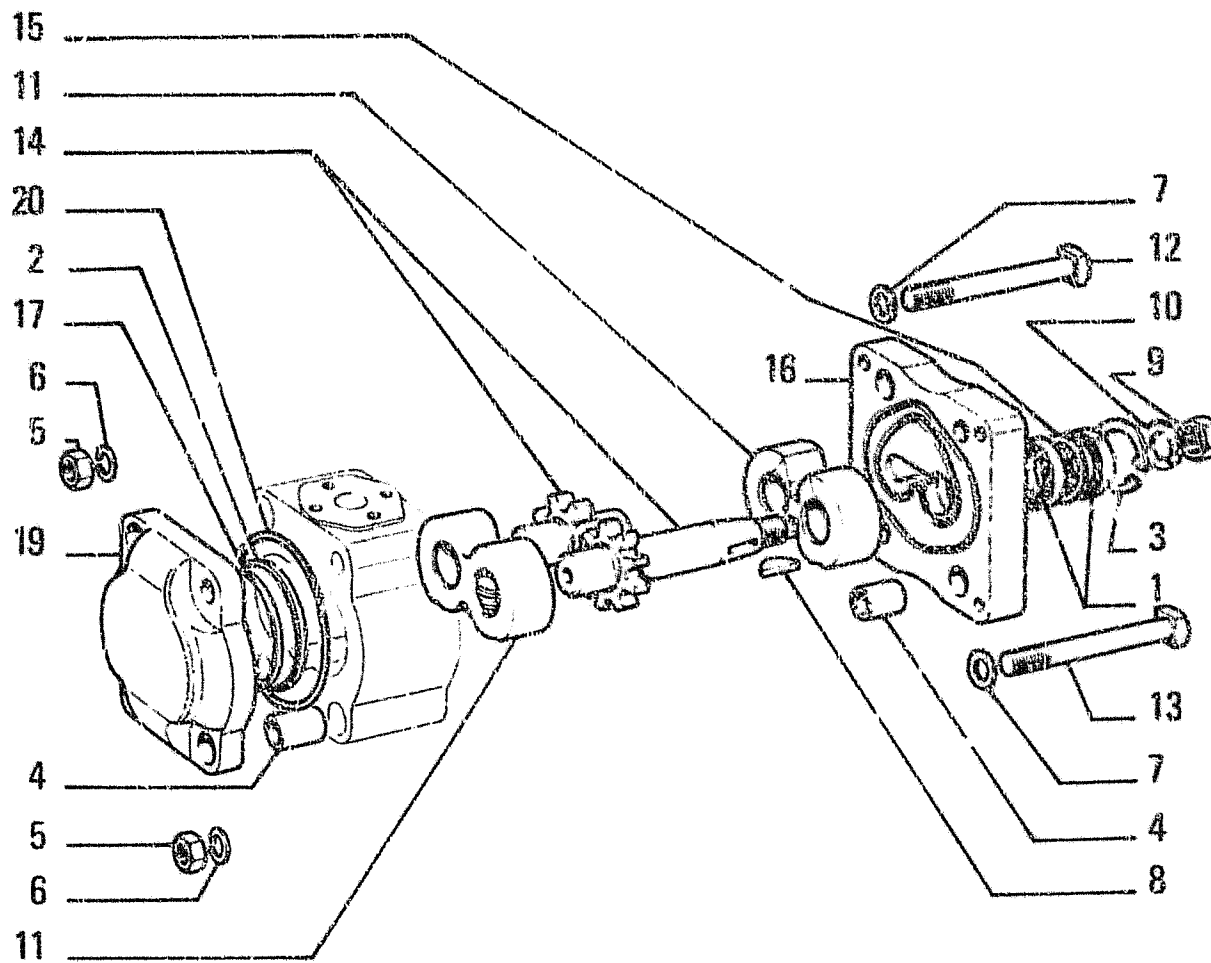

C1510 → tel. n. 250904

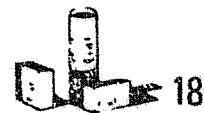

ITEM	PART NUMBER	QTY	TRANS CODE	DESCRIPTION	DESCRIZIONE
1	5110478	2	129G	SEAL ASSY	GUARNIZIONE TENUTA FRONTALE
2	8273909	2	158G	O-RING	GUARNIZIONE O-R
3	8273911	1	51A	LOCKRING	ANELLO DI SICUREZZA
4	8273912	4	95B	BUSHING	ROCCOLA
5	8273915	4	10D	NUT	DADO
6	8273916	4	132R	LOCKWASHER	ROSETTA DI SICUREZZA
7	8273917	4	131R	WASHER	ROSETTA
8	8273918	1	60L	KEY	LINGUETTA
9	8273919	1	10D	NUT	DADO
10	8273920	1	132R	LOCKWASHER	ROSETTA DI SICUREZZA
11	8273940	2	300S	SUPPORT	SUPPORTO
12	8273968	3	40V	SCREW	VITE
13	8273969	1	40V	SCREW	VITE
14	8274234	1	286C	GEAR SET	COPPIA DI INGRANAGGI
15	8280168	1	75D	SPACER	DISTANZIALE
16	8280169	1	70F	FLANGE	FLANGIA
17	8281201	2	158G	O-RING	GUARNIZIONE O-R
18	8281576	1	1K	KIT SEE PAGF 9	KIT VED. PAG.9
19	8283478	1	265C	COVER	COPERCHIO
20	14460380	2	158G	O-RING 2,62x64,77	GUARNIZIONE O-R 2,62x64,77

581610

PUMP - POMPA - POMPE - PUMPE - BOMBA

D2.27

N.T.R. 191 - 20.02.1990

604.01.081.04

M12

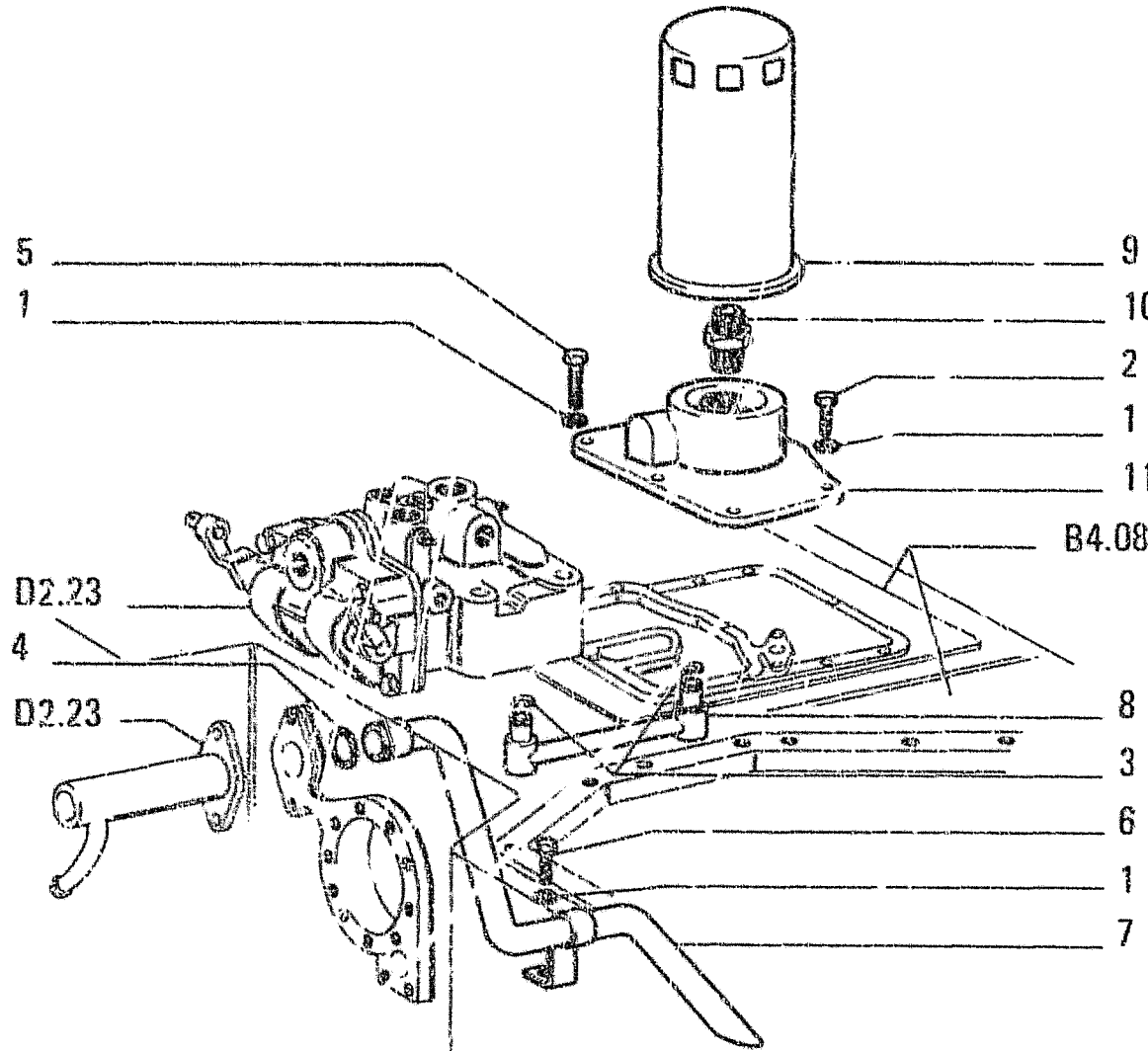

ITEM	PART NUMBFR	QTY	TRANS CODE	DESCRIPTION	DESCRIZIONE
1	10516871	7	132R	LOCKWASHER 10x2,5	ROSETTA DI SICUREZZA 10x2,5
2	11308931	1	40V	SCREW 10x1,25x30	VITE 10x1,25x30
3	13401176	2	51A	LOCKRING 20,2x24,2	ANELLO DI SICUREZZA 20,2x24,2
4	14463480	1	158G	O-RING 3,53x28,17	GUARNIZIONE O-R 3,53x28,17
5	15886731	5	40V	SCREW 10x1,25x55	VITE 10x1,25x55
6	15970531	1	40V	SCREW 10x1,25x20	VITE 10x1,25x20
7	79013538	1	193T	TUBE	TUBO RIGIDO
8	79023993	1	193T	TUBE C1519	TUBO RIGIDO C1519
	79044952	1	193T	TUBE D1519	TUBO RIGIDO D1519
9	79026104	1	67F	OIL FILTER	FILTRO OLIO
10	79026105	1	20R	FITTING	RACCORDO
11	79036601	1	300S	SUPPORT C1519	SUPPORTO C1519
	79044947	1	300S	SUPPORT D1519	SUPPORTO D1519

STEERING CLUTCHES LUBRICATION SYSTEM - LUBRIFICAZIONE FRIZIONE DI STERZO - GRAISSAGE DES EMBRAYAGES DE DIRECTION - SCHMIERUNG DER LENYREIBKUPPLUNGEN - ENGRASE DE EMBRAGUES DE DIRECTION

D2.24
N.T.R. 158 - 13.03.1987
604.01.081.03

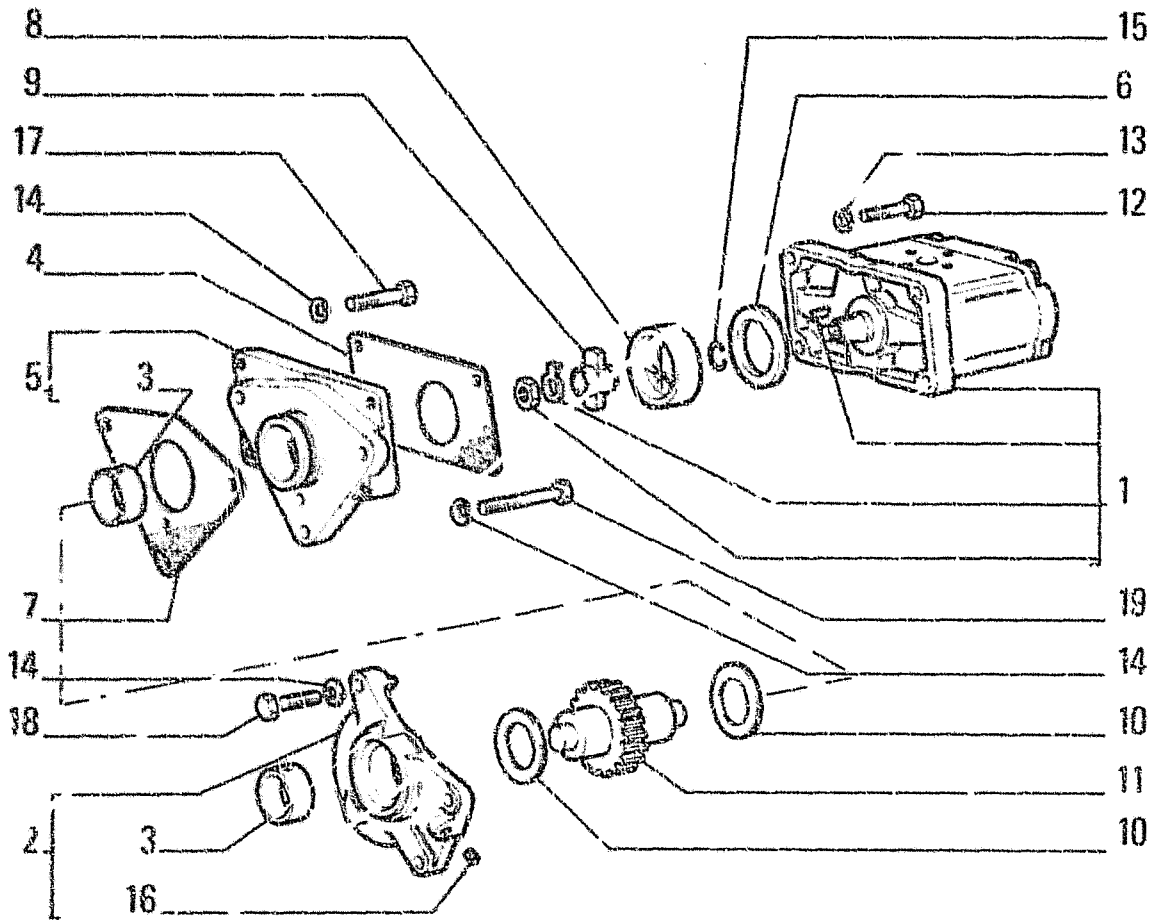

ITEM	PART NUMBER	QTY	TRANS CODE	DESCRIPTION	DESCRIZIONE
19	16044521	1	40V	SCREW 8x1,25x65	VITE 8x1,25x65
20	79066594	1	2K	KIT (*) D1409	KIT (*) D1409
(*)			7BP	FOR .. 79062723	PER 79062723

STEERING CLUTCHES HYDRAULIC CONTROL - COMANDO IDRAULICO FRIZIONI DI STERZO -
 COMMANDE HYDRAULIQUE DES EMBRAYAGES DE DIRECTION - HYDRAULIC. STEUERUNG DER
 LENKREIBKUPPLUNGEN - SISTEMA HIDRAULICO DE EMBRAGUES DE DIRECCION

D2.23

3

N.T.R. 200 - 15.10.1990

604.01.081.05

M14

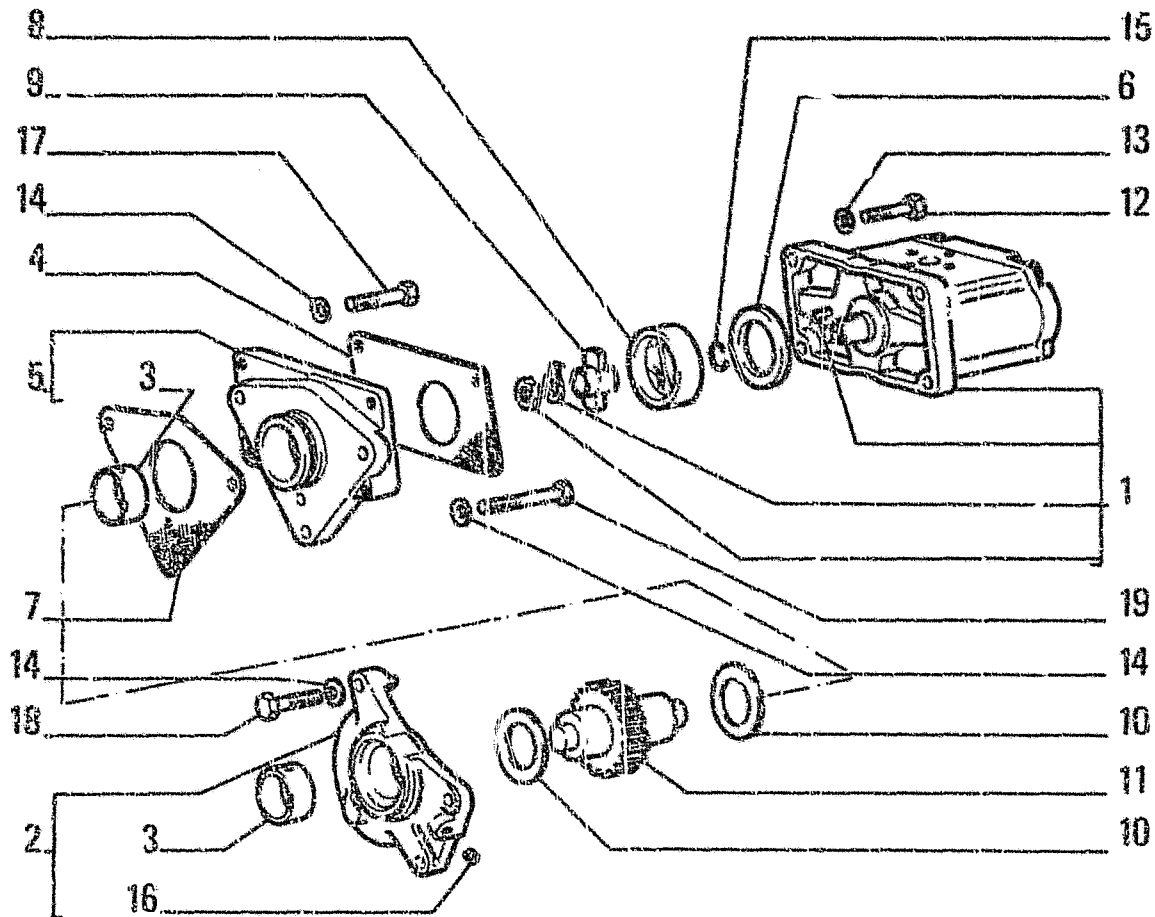

ITEM	PART NUMBER	QTY	TRANS CODE	DESCRIPTION	DESCRIZIONE
1	581610	1	153P	OIL PUMP - ASSEMBLY SEE SGR. D2.27 C1409	POMPA OLIO - COMPLETO VEDERE SGR. D2.27 C1409
	5120481	1	153P	OIL PUMP - ASSEMBLY SEE SGR. D2.27/A D1510	POMPA OLIO - COMPLETO VEDERE SGR. D2.27/A D1510
	79062723	1	153P	OIL PUMP - ASSEMBLY D1409	POMPA OLIO - COMPLETO D1409
		1	153P	OIL PUMP - ASSEMBLY C1510	POMPA OLIO - COMPLETO C1510
2	4607582	1	300S	SUPPORT - FRONT ASSEMBLY	SUPPORTO - ANTERIORE COMPLETO
3	4607586	1	95B	BUSHING	BOCCOLA
4	4607590	1	122G	SEAL C3341	GUARNIZIONE C3341
	4858082	1	122G	SEAL D3341	GUARNIZIONE D3341
5	4607593	1	300S	SUPPORT - REAR ASSEMBLY	SUPPORTO - POSTERIORE COMPLETO
6	4609538	1	45A	RING	ANELLO
7	4619405	1	122G	SEAL C3341	GUARNIZIONE C3341
	4858091	1	122G	SEAL D3341	GUARNIZIONE D3341
8	4621358	1	30M	SLEEVE	MANICOTTO
9	4630543	1	30M	SLEEVE	MANICOTTO
10	4667452	2	131R	WASHER	ROSETTA
11	4751151	1	16A	SHAFT	ALBERO
12	10902821	4	40V	SCREW 6x1x30	VITE 6x1x30
13	11197771	4	170R	LOCKWASHER 6,4x12	ROSETTA EL. 6,4x12
14	11198071	6	170R	LOCKWASHER 8,2x15	ROSETTA EL. 8,2x15
15	13398376	1	187A	SNAP RING 23,7x3	ANELLO ELASTICO 23,7x3
16	14327101	1	50T	PLUG 7x4	TAPPO 7x4
17	16043821	2	40V	SCREW 8x1,25x30	VITE 8x1,25x30
18	16043921	3	40V	SCREW 8x1,25x35	VITE 8x1,25x35

STEERING CLUTCHES HYDRAULIC CONTROL - COMANDO IDRAULICO FRIZIONI DI STERZO -
 COMMANDE HYDRAULIQUE DES EMBRAYAGES DE DIRECTION - HYDRAULIC. STEUERUNG DER
 LENKREIBKUPPLUNGEN - SISTEMA HIDRÁULICO DE EMBRAGUES DE DIRECCIÓN

D2.23

3

N. R. 200 - 15.10.1990

504.01.081.05

M15

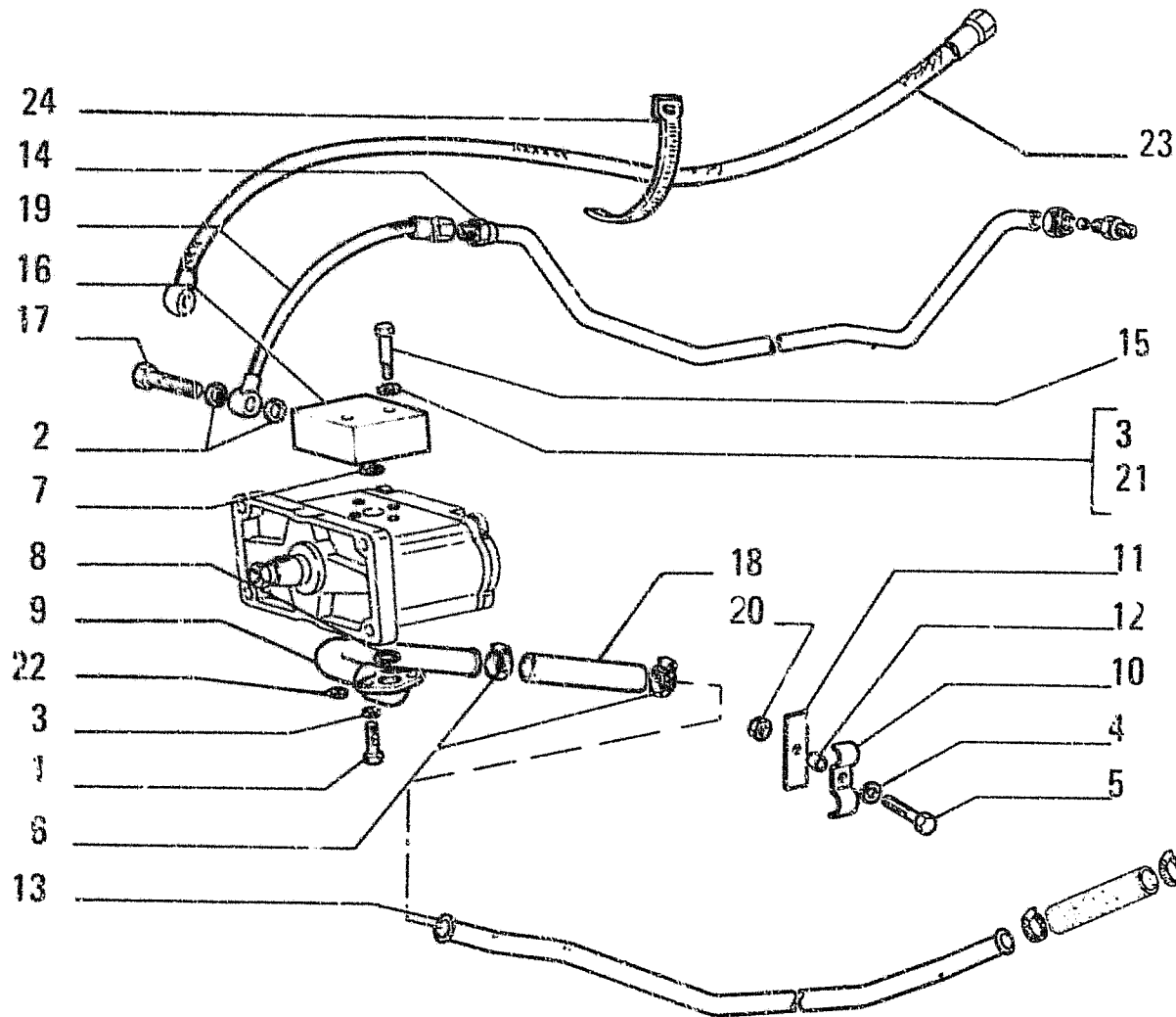

ITEM	PART NUMBER	QTY	TRANS CODE	DESCRIPTION	DESCRIZIONE
19	79034391	1	192T	HOSE ASSY C1520	TUBO FLESS.C/RACCORDI C1520
20	11701721	1	10D	NUT 10x1,5x8	DADO 10x1,5x8
21	10571579	2	170R	LOCKWASHER 6,1x1,5 D1510	ROSETTA EL. 6,1x1,6 D1510
22	14496501	2	131R	WASHER 8,4x17 D1510	ROSETTA 8,4x17 D1510
23	79043436	1	192T	HOSE ASSY D1520	TUBO FLESS.C/RACCORDI D1520
24	79013422	2	31F	CLAMP D1520	FASCETTA D1520

STEERING CLUTCHES HYDRAULIC CONTROL - COMANDO IDRAULICO FRIZIONI DI STERZO - COMMANDE HYDRAULIQUE DES EMBRAYAGES DE DIRECTION - HYDRAUL. STEUERUNG DER LENKREIBKUPPLUNGEN - SISTEMA HIDRAULICO DE EMBRAGUES DE DIRECCION

D2.23

2

N.T.R. 191 - 20.02.1990

604.01.081.04

M16

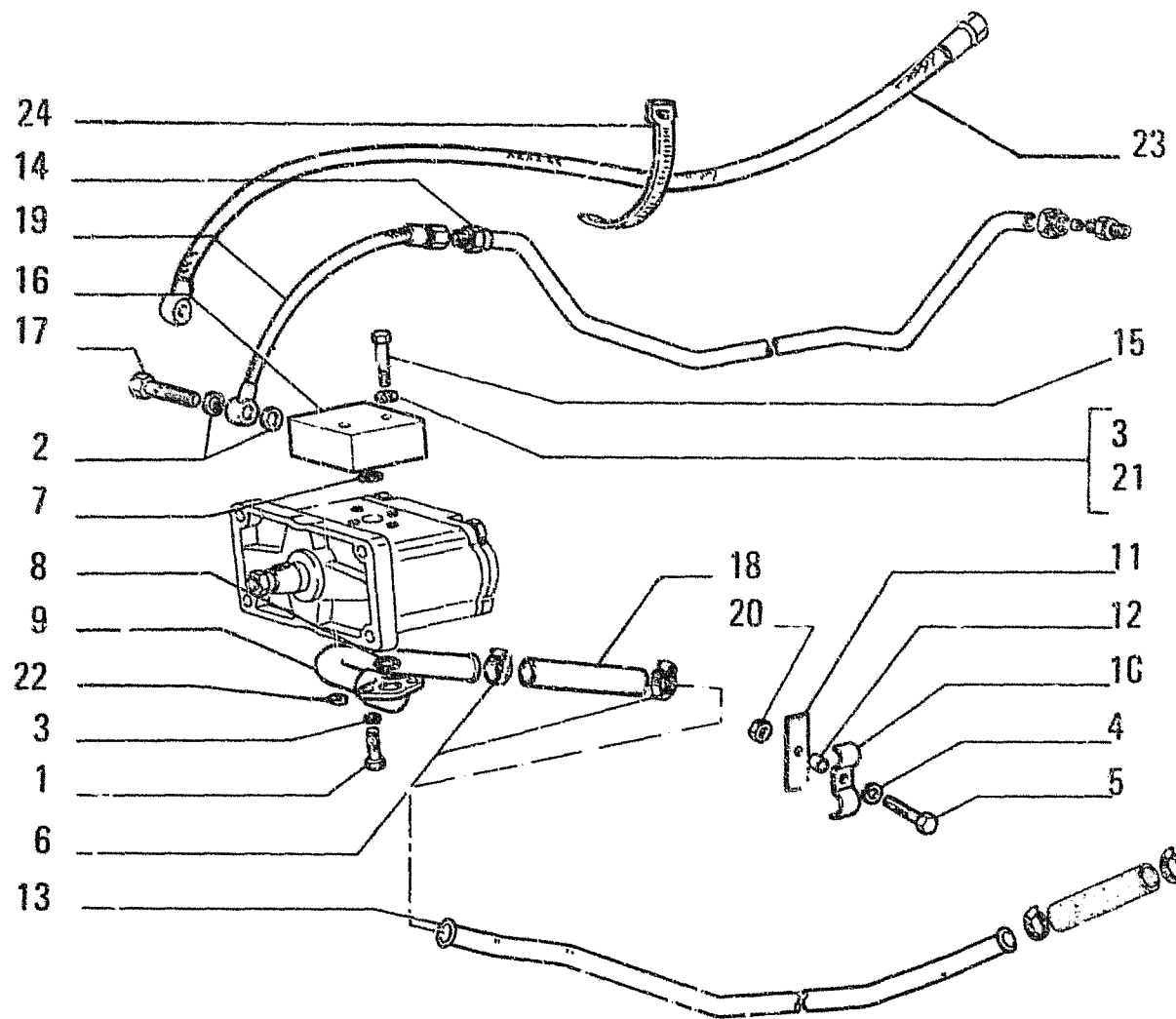

ITEM	PART NUMBER	QTY	TRANS CODE	DESCRIPTION	DESCRIZIONE
1	4969925	2	40V	SCREW C1510	VITE C1510
	16044031	2	40V	SCREW 8x1 25x40 D1510	VITE 8x1,25x40 D1510
2	10263460	2	133R	SEAL 22,2x28	ROSETTA DI TENUTA 22,2x28
3	10516671	2	170R	LOCKWASHER 8,1x2,2	ROSETTA EL 8,1x2,2
		2	170R	LOCKWASHER 8,1x2,2 C1510	ROSETTA EL 8,1x2,2 C1510
4	10516871	2	170R	LOCKWASHER 10x2,5	ROSETTA EL 10x2,5
5	11107031	2	40V	SCREW 10x1,5x45	VITE 10x1,5x45
6	12173990	4	180C	COLLAR 25/45x12 C2906	COLLARE 25/45x12 C2906
	79083844	2	1/8"IC	COLLAR D2906	COLLARE D2906
7	14457180	1	158G	O-RING 2,62x13,94	GUARNIZIONE O-R 2,62x13,94
8	14457480	1	158G	O-RING 2,62x18,72	GUARNIZIONE O-R 2,62x18,72
9	79017861	1	193T	TUBE - FRONT	TUBO RIGIDO - ANTERIORE
10	79015450	2	231S	CLIP C1520	STAFFETTA C1520
	79043442	2	231S	CLIP D1520	STAFFETTA D1520
11	79015882	2	61T	CUSHION PAD	TASSELLO ELASTICO
12	79016206	2	75D	SPACER	DISTANZIALE
13	79017862	1	193T	TUBE	TUBO RIGIDO
14	79017863	1	193T	TUBE C1520	TUBO RIGIDO C1520
15	10903631	2	40V	SCREW D1510	VITE D1510
	79019707	2	40V	SCREW C1510	VITE C1510
16	79020577	1	70F	FLANGE C1510	FLANGIA C1510
	79052017	1	70F	FLANGE D1510	FLANGIA D1510
17	79020859	1	20R	FITTING	RACCORDO
18	76015371	L	285T	HOSE 0,340M D2906	TUBO FLESSIBILE 0,340M D2906
	79032010	1	30M	SLEEVE C2906	MANICOTTO C2906

STEERING CLUTCHES HYDRAULIC CONTROL - COMANDO IDRAULICO FRIZIONI DI STERZO - COMMANDE 1
 HYDRAULIQUE DES EMBRAYAGES DE DIRECTION - HYDRAUL. STEUERUNG DER LENKREIBKUPPLUNGEN --
 SISTEMA HIDRAULICO DE EMBRAGUES DE DIRECCION

D2.23

2

N.T.R. 191 - 20.02.1990

604.01.081.04

M17

	DESIGNAZIONE BASE	BASIC DESIGNATION	DESIGNATIONS-BASES	GRUNDBEZEICHNUNGEN	DENOMINACIONES BASE
168T	TRASPARENTE DELL'INDICATORE DI	DIRECTION INDICATOR LAMP LENS	TRANSPARENT D IN-	LICHTSCHEIBE DER	TAPA TRANSLUCIDA
168T	DIREZIONE		DICATEUR DE DIREC-	BLINKLEUCHTE	DEL INDICADOR DE
168T			TION		DIRECCION
169C	CILINDRO DI DISINNESTO	RELEASE CYLINDER	CYLINDRE DE DEBRA-	ARBEITSZYLINDER	CILINDRO DE EM-
169C			YAGE		BRAGUE
169P	POMPETTA	PUMP, WASHER	POMPE	PUMPE	BOMBA
169R	REGOLATORE	REGULATOR	REGULATEUR	REGLER	REGULADOR
169T	TRASPARENTE CON CATADIOTTRO	LENS AND REFLEX-REFLECTOR	TRANSPARENT ET	LICHTSCHEIBE MIT	TAPA TRANSLUCIDA
169T			CATADIOPTRE	RUECKSTRAHLER	CON CATAFAPOS
176A	RAFFREDDAMENTO MOTORE	ENGINE COOLING SYSTEM	REFROIDISSEMENT MOIEUR		
176A				LEITUNGEN MOTORKUEHL SYSTEM	
1762	TUBAZIONI RAFFREDD.MOTORE	ENGINE COOLING PIPING		DICHTUNG FUER LUFTANLAGE	
1765	ELEMENTI TENUTA ARIA	AIR-TIGHT ELEMENT	ELEMENTS ETANCHEITE D AIRE	HAUPTZYLINDER	CILINDRO PRINCIPAL
170C	CILINDRO MAESTRO	MASTER CYLINDER	MAITRE-CYLINDRE	ANHAENGERKUPPLUNG	BRIDA
170P	MONTICELLO	BRIDGE PIECE	CHAPE D ATTELAGE	FEDERRING	ARANDELA DE FRENO
170R	MOSETTA EL.	LOCKWASHER	RONDELLE A RESSORT	ENTSTOERER	SUPRESOR
170S	SOPPRESSORE	SUPPRESSOR	RESISTANCE	LICHTSCHEIBE	TRANSLUCIDO
170T	TRASPARENTE	LENS	TRANSPARENT	ZYLINDER	CILINDRO DE MANDO
171C	CILINDRO OPERATORE	OPERATING CYLINDER	CYLINDRE DE COM-		
171C			MANDE		
171R	RIFLETTORE	REFLECTOR	REFLECTEUR	REFLEKTOR	REFLECTOR
171S	SOPRASUOLA	STREET PLATE	PATIN DE ROUTE	STRASSENSCHUH	PATIN DE CARRETERA
172C	CINGHIA DI FISSAGGIO	SECURING STRAP	SANGLE DE FIXATION	HALTERIEMEN	CORREA DE FIJACION
172S	SOSPENSIONE	SUSPENSION	SUSPENSION	AUFHAENGUNG	SUSPENSION
173C	CINGHIA	BELT	COURROIE	KEILRIEMEN	CORREA
173R	RALLA ROTAZIONE	BULL GEAR	CRAPAUDINE	DREHKRANZ	RUEDA DE DIENTES-EXCAVADORA
174C	CINGHIE	BELTS	COURROIS	RIEMEN	CORREAS
174R	RALLA PORTALAMA	CIRCLE	CERCLE	KUGELAUFNAHME	RUEDA DE DIENTES-MOTONIVELADOR
174S	SOSTEGNO	SACE	SUPPORT	STUETZE	SOPORTE
175R	REGOLATORE MECCANICO	GOVERNOR	REGULATEUR	MECHANISCHER REGLER	REGULADOR
176C	COFANO	HOOD	CAPOT	MOTORHAUBE	CAPOT
176R	RUSPA	SCRAPER	DECROTTOIR	ABSTREICHER	LIMPIADOR
177R	RUOTA COMPATTATORE	PADFOOT WHEEL			
177S	SPAZZOLA	BRUSH	BALAI	KOHLLENBUERSTE	ESCOBILLA
178C	CINGOLO	TRACK	CHEVILLE	RAUPENKETTE	ORUGA
180C	COLLARE	COLLAR	COLLIER	ROHRSCHELLE	COLLAR
180P	PORTA	DOOR	PORTE	TUER	PUERTA
180T	TRAVERSA	CROSS BEAM	TR.AVERSE	TRAVERSE	TRAVESANO
181T	TRAVERSA DI TRAINO	DRAWBAR FRAME	TRAVERSE D'ATTACHE	ACKERSCHIENE	TRAVIESA PERFORADA
181T			GE		
182C	CINTURA DI SICUREZZA	SAFETY BELT	CEINTURE DE SECURITE	SICHERHEITSGURT	CINTURON DE SEGURIDAD

DESIGNAZIONE BASE	BASIC DESIGNATION	DESIGNATIONS BASES	GRUNDBEZEICHNUNGEN	DENOMINACIONES BASE
1821	SOLLEVATORE IDRAULICO (VELOCE)		HEBUNG HYDRAULIQUE (RAPIDE)	
183P	PORTACENERIE	ASHTRAY	CENDRIER	ASCHENBECHER
184C	COLONNETTA	STUD	COLONNETTE	SCHRAUBENBOLZEN
184S	SPECCHIO	MIRROR	MIROIR	SPIEGEL
185C	CHiodo	NAIL	CLOU	NIET
185P	PORTACONTATTI	CONTACT CARRIER	PORTE-CONTACTS	KLEMMENHALTER
185S	SPECCHIO RETROVISORE	REAR VIEW MIRROR	RETROVISEUR	RUECKSPIEGEL
186A	ALBERO RETROMARCIA	REVERSE SHAFT	ARBRE ARRIERE	WELLE-RUECKWAERTSGANG
187A	ANELLO ELASTICO	SNAP RING	ARRETOIR	SPANNRING
187C	COMANDO CADUTA LIBERA DI EMERGENZA	FREE FALL CONTROL	COMMANDE DE CHUTE	NOTSTEUERUNG DES F
187C			GENCE	
188A	APPENDIABITI	COAT-HOOK	PORTEMANTEAUX	KLEIDERHAKEN
188C	COLLETORE	MANIFOLD	COLLECTEUR	KRUEMMER
188P	PORTAFUSIBILE	FUSE HOLDER	PORTE-FUSIBLE	SICHERUNGSSHALTER
188A	ATTUATORE DI ROTAZIONE	SLEWING ACTUATOR	GROUPE DE ROTATION	DRIFLAGGREGAT
189C	COMANDO	CONTROL	COMMANDE	BETAETIGUNGS-VORRICHT
189C				LEITUNGEN FUER MOTORLUFTFILTER
1937	TUBAZIONI MOTORE-FILTRO ARIA	ENGINE TO AIR CLEANER LINES		MEHRMENGENSYSTEM
190A	ARRICCHITORE	EXCESS FUEL	DISPOSITIF CONTROLE	
190A			INTRODUCTION	
190C	COMANDO A MANO	HAND CONTROL	COMMANDE A MAIN	HANDBETAETIGUNG
190S	SPECIALE PER RICAMBI	SPECIFIC FOR REPLACEMENTS	SPECIAL POUR	EXTRA FUER DEN
190S			RECHANGES	ERSATZ
190T	TUBAZIONE	LINE	TUYAU	LEITUNG
191C	COMANDO A PEDALE	FOOT CONTROL	COMMANDE AU PIED	FUSSHEBEL
192C	COMANDO DELL'AVVISATORE	HORN BUTTON	COMMANDE D'AVERTISSEUR	HORNBEAETIGUNG
192C				
192P	PORTAOGGETTI	UTILITY HOLDER	PORTE-OBJETS	ABLAGE
192T	TUBO FLESS. C/RACCORDI	HOSE ASSY	TUYAU FLEXIBLE	SCHLAUCH MIT STUTZEN
193C	COMANDO PNEUMATICO	AIR CONTROL	COMMANDE PNEUMATIQUE	PNEUMAT BETAETIGUNG
193C				
193P	PORTALAMPADA	BULB HOLDER	PORTE-LAMPE	LAMPENFASSUNG
193T	TUBO RIGIDO	TUBE	TUYAU	ROHR
194C	COMANDO ELETTROPNEUMATICO	ELECTRO-PNEUMATIC CONTROL	COMMANDE ELECTRO-PNEUMATIQUE	ELEKTROPNEUMATISCHE BETAETIGUNG
194C				
195C	COMANDO FLESSIBILE	BOWDEN ASSY.	TIRETTE DE COMMANDE	BOWDENZUG
195C				
195P	PORTAPOLVERIZZATORE	NOZZLE HOLDER	PORTE-PULVERISATEUR	DUESENSTOCK
195T	TUBETTO	TUBE	TUBE	ROHR
196P	PORTASATELLITI	PLANETARY HUB	PORTE-SATELLITES	PLANFTENTRAEGER

DESIGNAZIONE BASE	BASIC DESIGNATION	DESIGNATIONS-BASES	GRUNDEZEICHNUNGEN	DENOMINACIONES BASE
196S	SPERONE	TRACK FRAME END	GUIDE CRENILLES	ESPOLON
196T	TUBETTO ISOLANTE	INSULATING SHEAT	TUBE ISOLANT	TUBO AISLANTE
197C	COMANDO ACCELERATORE	THROTTLE CONTROL	COMMANDE D'ACCELERATEUR	MANDO DEL ACELERADOR
197P	PORTASPAZZOLA	BRUSH HOLDER	PORTE-BALAI	PORTAESCOBILLA
197S	SPESSORE ELASTICO	PAD	CALE ELASTIQUE	SUPLEMENTO ELASTICO
197S				
197T	TUBETTO STRINGIFILO	FERRULE	TUBE D'ATTACHE	TUBITO DE FIJACION
198C	COMANDO A MANO STARTER	CHOKE CONTROL	COMMANDE A MAIN DE STARTER	MANDO MANUAL DE STARTER
198C				
199P	PIASTRA PORTATARGA	PLATE SUPPORT	PORTE-PLAQUE	SOPORTE DE PLACA
198S	SPESSORE	SHIM	CALE D'EPAISSEUR	ESPESOR
199C	COLTELLO BENNA	BUCKET CUTTING EDGE	COUPEAU DU GODET	CUCHILLA
199S	SPESSIMETRO	FEELER GAUGE	JAUGE D'EPaisseur	CALIBRE
200C	COMANDO SICUREZZA	SAFETY CONTROL	COMMANDE DE SECURITE	PESTILLO DE SEGURIDAD
200C				
200P	PREMIGUARNIZIONE	EXPANDER	PRESSE-JOINT	ELEMENTO SEPARADOR
200S	SPINA	PIN	GOUPILLE	PASADOR
200T	TUBO DI INTRODUZIONE	FILLER TUBE	TUBULURE DE REMPLISSAGE	CUELLO DE CARGA
200T				
200V	VALVOLA AUTOMATICA DI SCARICO	AUTOMATIC DRAIN VALVE	SOUPAPE AUTOMATIQUE DE DETENTE	VALVULA DE DESCARGA AUTOMATICA
200V				
201P	PREFILTRO	PRECLEANER	PREFILTRE	PREFILTRO
201S	SPINA ELETTRICA	ELECTRICAL PLUG	FIGE ELECTRIQUE	ENCHUFE
201V	VALVOLA AUTOMATICA DI SPURGO	AUTOMATIC BLEED VALVE	PURGEUR AUTOMATIQUE	VALVULA DE PURGA AUTOMATICA
201V				
202C	COMMUTATORE CON ANTIFURTO	KEY SWITCH WITH THEFT DEVICE	COMMUTATEUR AVEC ANTIVOL	CONMUTADOR CON DISP.ANTIRROBO
202C				
202P	POSIZIONATORE	POSITIONER	POSITIONNEUR	POSICIONADOR
202S	SPINA ELASTICA	SPRING PIN	GOUPILLE ELASTIQUE	PASADOR ELASTICO
203S	SPONDA	SIDE	RIDELLE	LADO
203V	VALVOLA DI ALIMENTAZIONE	FEED VALVE	SOUPAPE D'ALIMENTATION	VALVULA DE ALIMENTACION
203V				
204P	PRESA ARIA	AIR INTAKE	PRISE D'AIR	BOCA DE AIRE
205P	PRESA DI CORRENTE	RECEPTACLE	PRISE DE COURANT	TOMA DE CORRIENTE
205S	SPORTELLO	DOOR	VOLET	POSTIGO
207P	PRESA DI FORZA	POWER TAKE-OFF	PRISE DE FORCE	TOMA DE FUERZA
207T	TUBO DI SFIATO	VENT PIPE	TUBE D'EVENT	TUBO DE VENTILACION
207T				
209T	TURBINA	TURBINE	TURBINE	TURBINA
21G3	ARTICOLAZIONE TELAI	MAIN FRAME ARTICULATION	ARTICULATION DES CHASSIS	

D	FRAME • STEERING • SUSPENSIONS • WHEELS • UNDERCARRIAGE • HYDRAULIC TRANSMISSION TELAI • STERZO • SOSPENSIONI • RUOTE • CINGOLATURA • TRASMISSIONE IDRAULICA CADRE • DIRECTION • SUSPENSIONS • ROUES • TRAIN DE ROULEMENT • TRANSMISSION HYDRAULIQUE RAHMEN • LENKUNG • AUFHÄNGUNGEN • RÄDER • KETTENLAUFWERK • HYDRAULISCHER ANTRIEB BASTIDOR • DIRECCIÓN • SUSPENSIÓN • RUEDAS • TREN DE RODAJE • TRANSMISIÓN HIDRÁULICA
E	AUXILIARY ATTACHMENT (AND EQUIPMENT) • ORGANI SUSSIDIARI (E ATTREZZI) • ORGANES AUXILIAIRES (ET EQUIPEMENT) • NEBENAGGREGATE (UND GERÄTE) • GRUPOS AUXILIARES (Y EQUIPO)

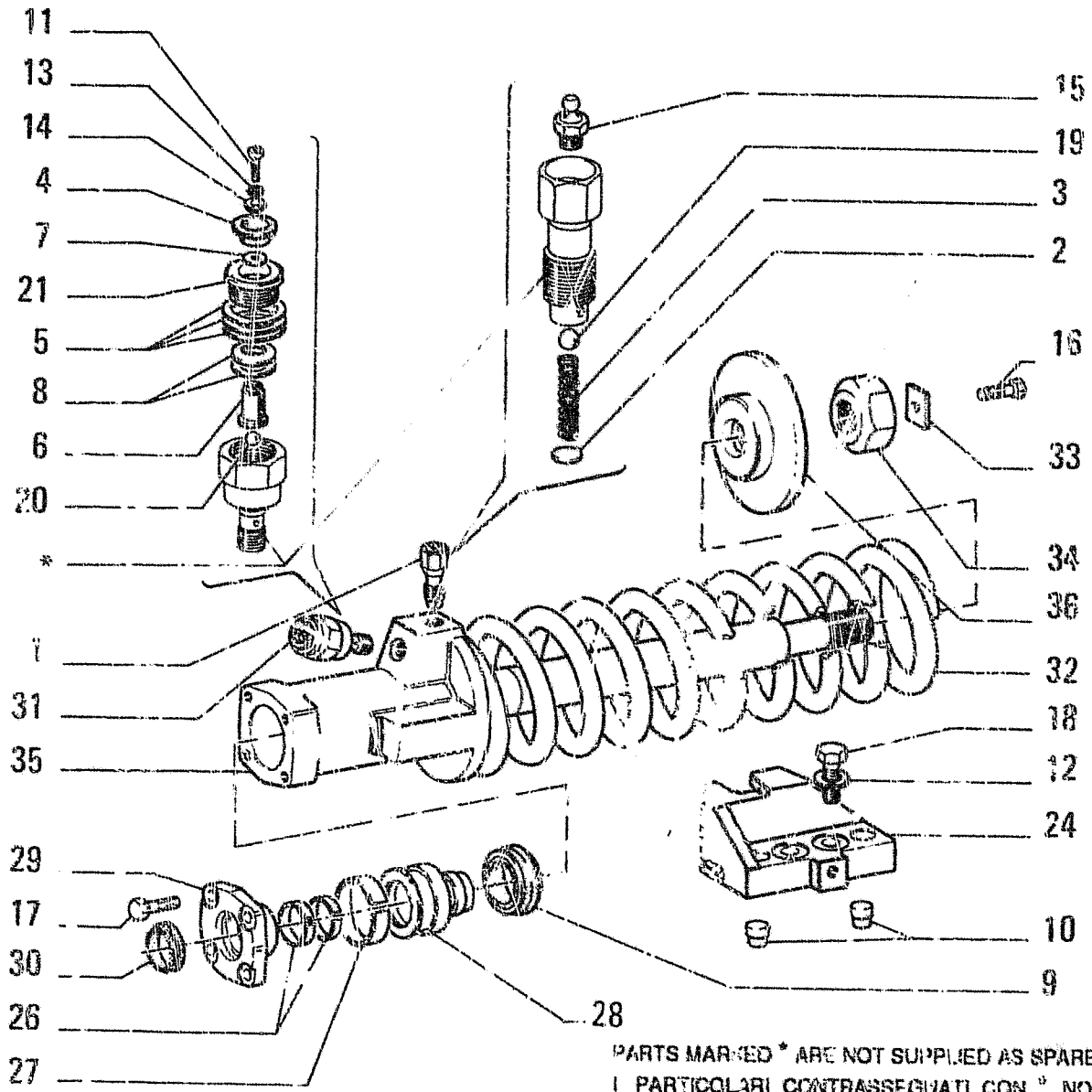

PARTS MARKED * ARE NOT SUPPLIED AS SPARES
 I PARTICOLARI CONTRASSEGNA TI CON * NON
 VENGONO FORNITI DI RICAMBIO

ITEM	PART NUMBER	QTY	TRANS CODE	DESCRIPTION	DESCRIZIONE
27	79012677	2	45A	RING	ANELLO
28	79012678	2	235S	PISTON	STANTUFFO
29	79012681	2	265C	COVER	COPERCHIO
30	79012682	2	158G	O-RING	GUARNIZIONE O-R
31	79019557	2	9V	SAFETY VALVE - ASSEMBLY	VALVOLA SICUREZZA - COMPLETO
				C1178	C1178
	79043805	2	9V	SAFETY VALVE - ASSEMBLY	VALVOLA SICUREZZA - COMPLETO
				D1178	D1178
32	79034260	2	100M	SPRING	MOLLA
33	79040203	2	113P	PLAQUE	PIASTRINA
34	79040204	2	10D	NUT	DADO
35	79040208	2	164C	CYLINDER	CILINDRO
36	79040915	2	10D	DISC	DISCO

IDLER WHEEL -- TENDICINGOLO -- ROJETENDEUSE -- RAUPENKETTENSANNER -- RUEDA GUIADORA

D3.34 1
 N.T.R. 15 - 28.11.1986
 604.0 081.02

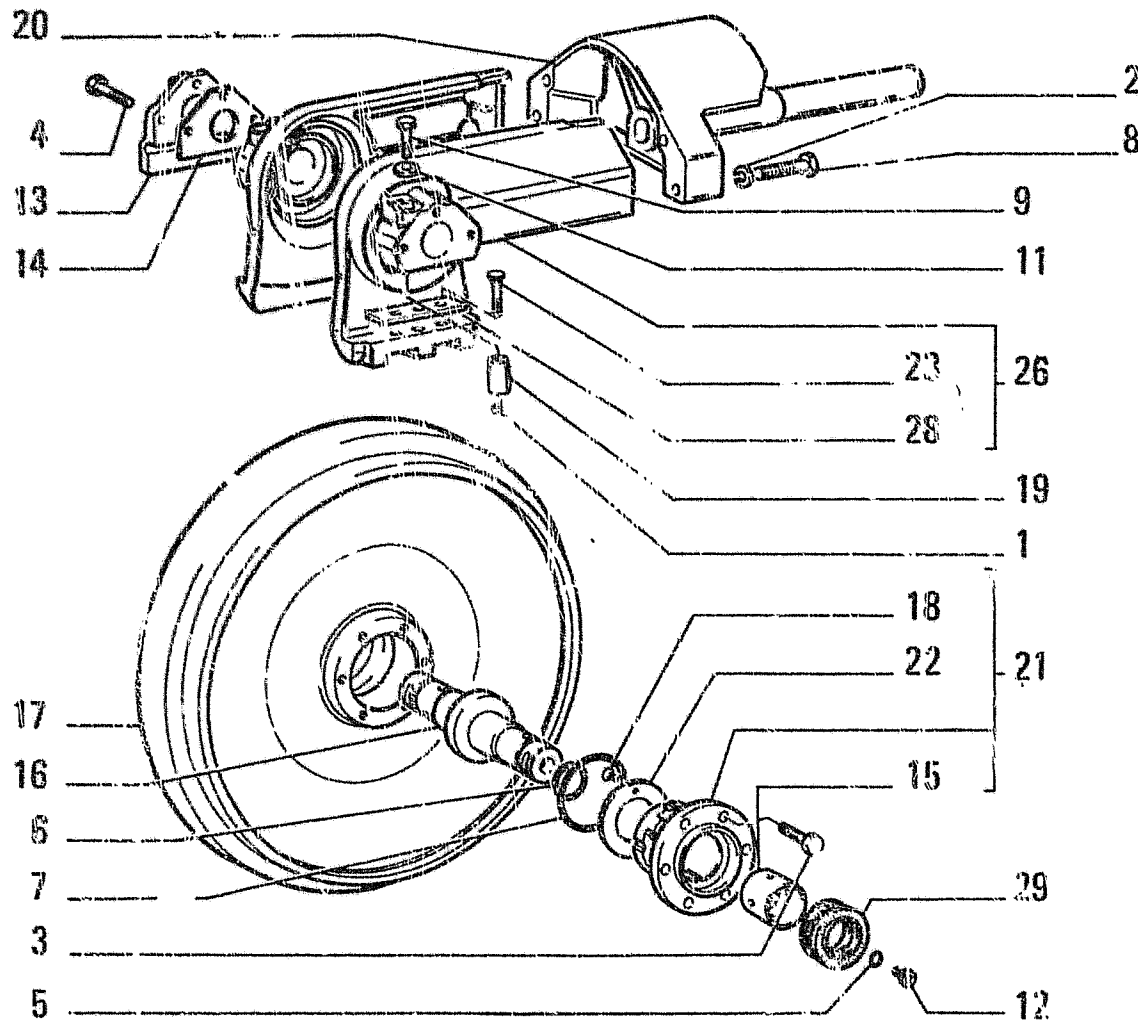

ITEM	PART NUMBER	QTY	TRANS CODE	DESCRIPTION	DESCRIZIONE
1	563024	4	50T	PLUG	TAPPO
2	10517071	8	132R	LJCKWASHER 12,2x3,1	ROSETTA DI SICUREZZA 12,2x3,1
3	14238131	24	40V	SCREW 8x1,25x25	VITE 8x1,25x25
4	14274631	12	40V	SCREW 12x1,25x35	VITE 12x1,25x35
5	14457030	2	158G	O-RING 2,62x12,37	GUARNIZIONE O-R 2,62x12,37
6	14454080	4	158G	O-RING 3,53x37,69	GUARNIZIONE O-R 3,53x37,69
7	14465380	4	158G	O-RING 3,53x78,97	GUARNIZIONE O-R 3,53x78,97
8	15541131	8	40V	SCREW 12x1,25x65	VITE 12x1,25x65
9	16041631	4	40V	SCREW 10x1,25x50	VITE 10x1,25x50
11	79012675	4	131R	WASHER	ROSETTA
12	79019318	2	50T	PLUG	TAPPO
13	79019406	4	105P	PLATE	PIASTRA
14	79019407		198S	SHIM	SPESSORE
15	79020691	4	95B	BUSHING	BOCCOLA
16	79021065	2	16A	SHAFT	ALBERO
17	79021584	2	160R	WHEEL	RUOTA
18	79023131	8	40V	SCREW	VITE
19	79023955	4	80P	PIN	PERNO
20	79025271	2	300S	SUPPORT	SUPPORTO
21	79029122	4	35S	CASE - ASSEMBLY	SCATOLA - COMPLETO
22	79029123	4	23R	THRUST PLATE	RALLA DI SPINTA
23	79033531	12	40V	SCREW	VITE
26	79033535	2	300S	SUPPORT - RIGHT	SUPPORTO - DESTRO
	79033536	2	300S	SUPPORT - LEFT	SUPPORTO - SINISTRO
28	79033537	4	45P	PAD	PATTINO
29	79033719	4	158G	O-RING	GUARNIZIONE O-R

IDLER WHEEL - TENDICINGOLO - ROUE TENDEUSE - RAUPENKETTENSANNER - RUEDA GUIADORA

D3.34

2

N.T.R. 205 - 30.09.1991
604.01.081.06

N3

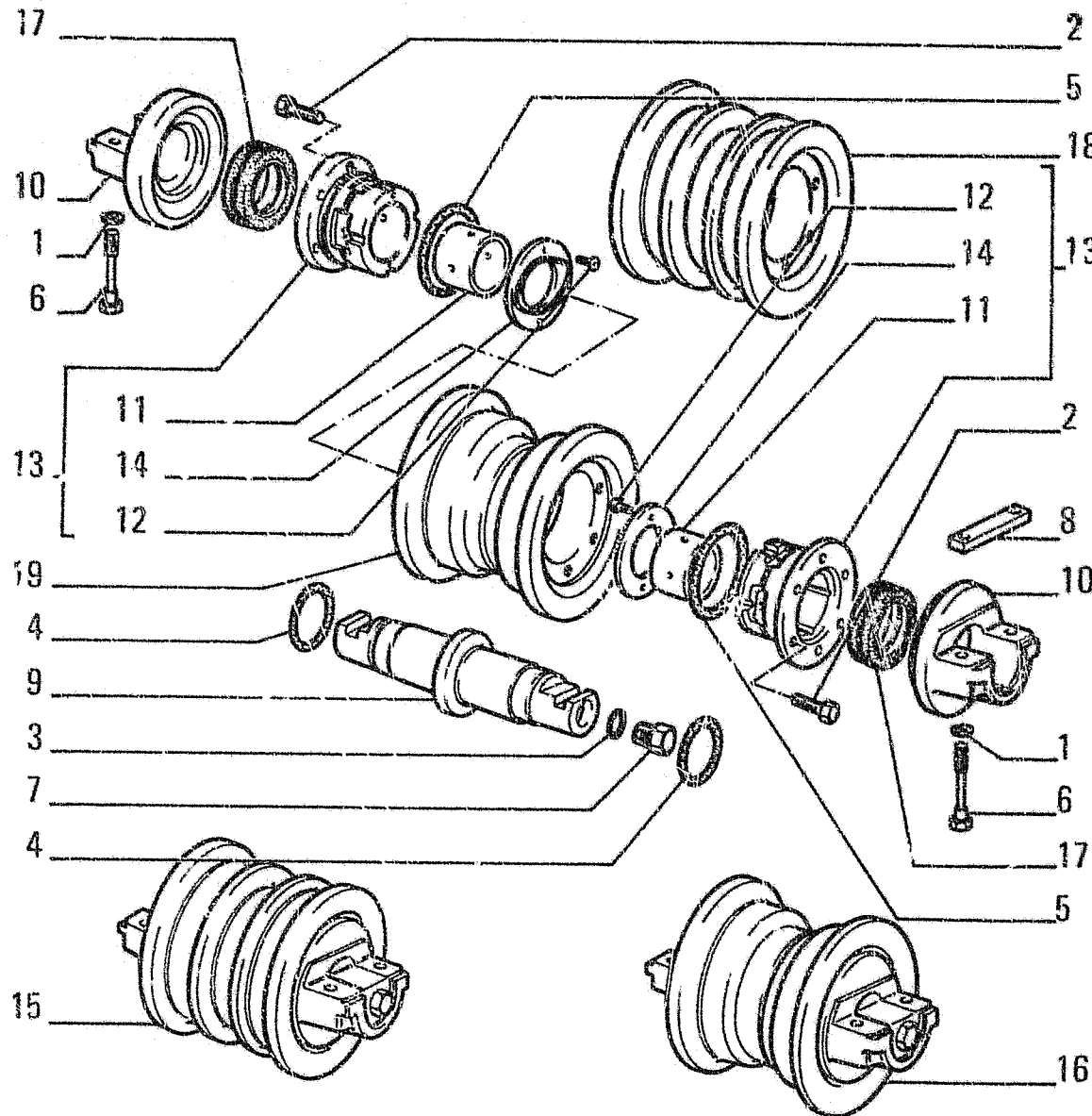

ITEM	PART NUMBER	QTY	TRANS CODE	DESCRIPTION	DESCRIZIONE
1	10572071	40	131R	WASHER 14,2x3	ROSETTA 14,2x3
2	14238131	120	40V	SCREW 8x1,25x25	VITE 8x1,25x25
3	14457080	10	158G	O-RING 2,62x12,37	GUARNIZIONE O-R 2,62x12,37
4	14464080	20	158G	O-RING 3,53x37,69	GUARNIZIONE O-R 3,53x37,69
5	14465380	20	158G	O-RING 3,53x78,97	GUARNIZIONE O-R 3,53x78,97
6	15977531	40	40V	SCREW 14x1,5x60	VITE 14x1,5x60
7	79019318	10	50T	PLUG	TAPPO
8	79020682	20	60L	KEY	LINGUETTA
9	79020689	10	16A	SHAFT	ALBERO
10	79020690	20	300S	SUPPORT	SUPPORTO
11	79020691	2	95B	BUSHING	BOSCOLA
12	79023131	4	40V	SCREW	VITE
13	79029122	20	35S	CASE - ASSEMBLY	SCATOLA - COMPLETO
14	79029123	2	23R	THRUST PLATE	RALLA DI SPINTA
15	79029124	4	157R	ROLLER - ASSEMBLY	RULLO - COMPLETO
16	79029125	6	157R	ROLLER - ASSEMBLY	RULLO - COMPLETO
17	79033719	20	158G	O-RING	GUARNIZIONE O-R
18	79039719	4	157R	ROLLER	RULLO
19	79039721	0	157R	ROLLER	RULLO

TRACK ROLLER - RULLO CARRELLO CINGOLO - GALET PORTEUR DE CHENILLE - LAUFROLLE
 DER RAUPENKETTE - RODILLO DE APOYO DE LA ORUGA

D3.37

N.T.R. 205 - 30.09.1991
 604.01.081.06

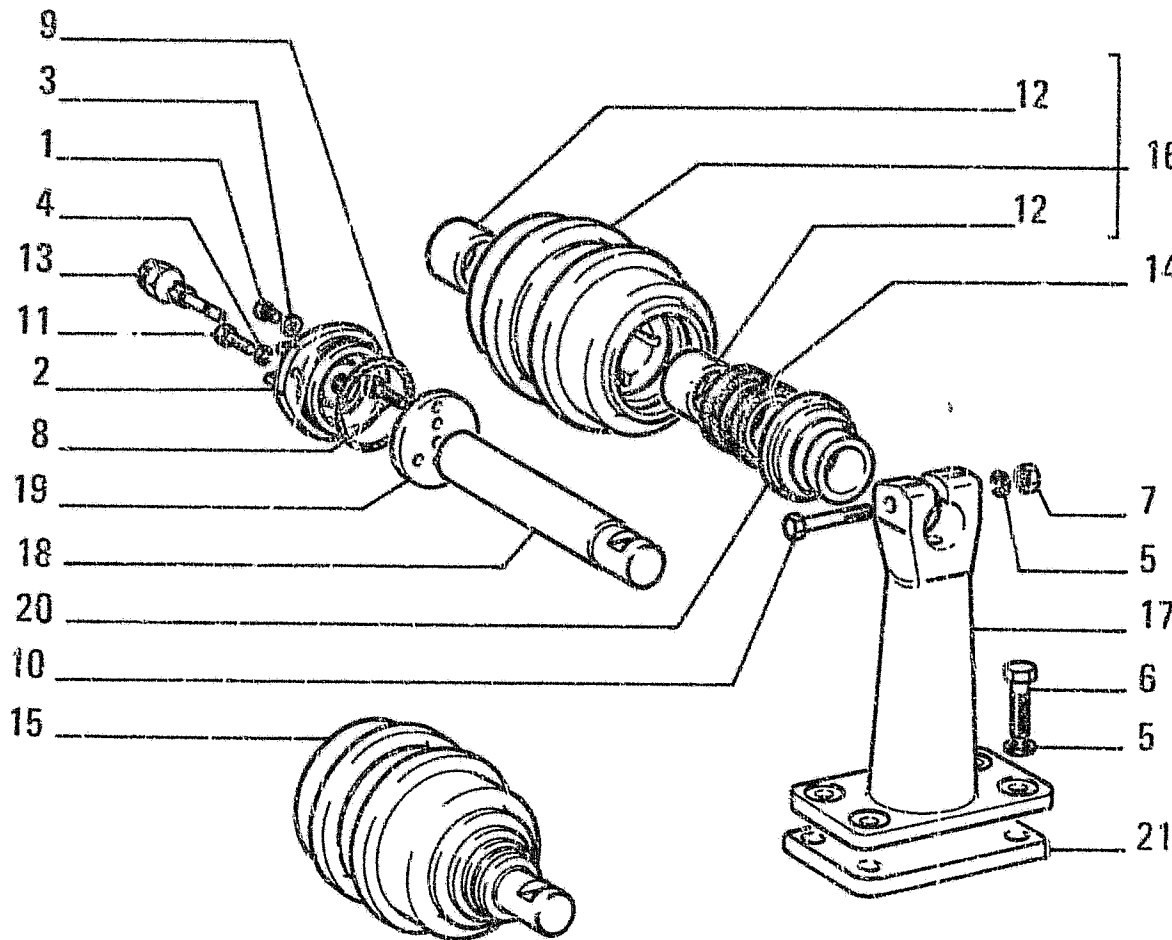

ITEM	PART NUMBER	QTY	TRANS CODE	DESCRIPTION	DESCRIZIONE
1	581658	2	50T	PLUG	TAPPO
2	597869	2	265C	COVER	COPERCHIO
3	10260060	2	133R	SEAL 8,2x14	ROSETTA DI TENUTA 8,2x14
4	10516671	6	132R	LOCKWASHER 8,1x2,2	ROSETTA DI SICUREZZA 8,1x2,2
5	10517171	10	132R	LOCKWASHER 14,2x3,5	ROSETTA DI SICUREZZA 14,2x3,5
6	11227031	8	40V	SCREW 14x1,5x65	VITE 14x1,5x65
7	12164021	2	10D	NUT 14x1,5x11	DADO 14x1,5x11
8	14238130	4	40V	SCREW 8x1,25x25	VITE 8x1,25x25
9	14465180	2	158G	O-RING 3,53x72,62	GUARNIZIONE O-R 3,53x72,62
10	15862131	2	40V	SCREW 14x1,5x80	VITE 14x1,5x80
11	16043631	6	40V	SCREW 8x1,25x25	VITE 8x1,25x25
12	79009877	4	95B	BUSHING	BOCCOLA
13	79010932	2	60I	GREASE FITTING	INGRASSATORE
14	79020694	2	158G	O-RING	GUARNIZIONE O-R
15	79021810	2	157R	ROLLER - ASSEMBLY	RULLO - COMPLETO
16	79021814	2	157R	ROLLER - ASSEMBLY	RULLO - COMPLETO
17	79021815	2	300S	SUPPORT	SUPPORTO
18	79021817	2	16A	SHAFT	ALBERO
19	79021818	2	45A	RING	ANELLO
20	79021819	2	45A	RING	ANELLO
21	79025283	2	75D	SPACER	DISTANZIALE

TRACK CARRIER ROLLER - RULLO SOSTEGNO CINGOLO - GALET DE RETOUR DE CHENILLE -
 STUETZROLLE DER RAUPENKETTE - RODILLO DE SOPORTE DE LA ORUGA

D3.38

N.T.R. 152 - 28.11.1986

604.01.081.02

N5

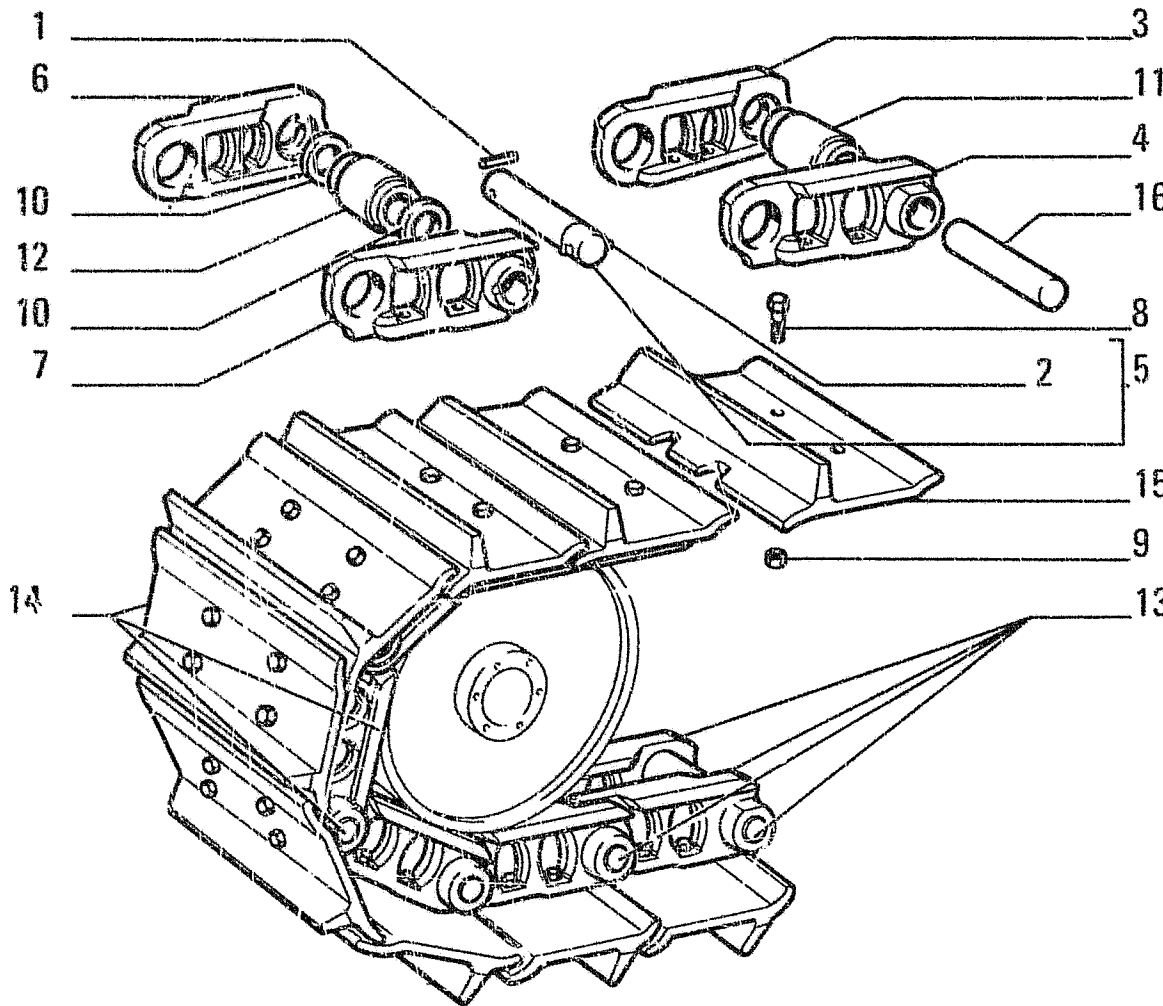

C 2869 -- Tel.n. 251325

ITEM	PART NUMBER	QTY	TRANS CODE	DESCRIPTION	DESCRIZIONE
1	14607570	2	200S PIN 8x55		SPINA 8x55
2	76004958	1	200S PIN		SPINA
3	79012409	74	10M LINK DS.		MAGLIA DS.
4	79012410	74	10M LINK - LEFT		MAGLIA - SINISTRO
5	79012413	2	80P PIN - ASSEMBLY		PERNO - COMPLETO
6	79012414	2	10M LINK - RIGHT		MAGLIA - DESTRO
7	79012415	2	10M LINK - LEFT		MAGLIA - SINISTRO
8	76008353	304	40V SCREW D1508		VITE D1508
	79012420	304	40V SCREW C1508		VITE C1508
9	76008354	304	10D NUT D1508		DADO D1508
	79012421	304	10D NUT C1508		DADO C1508
10	79023843	4	75D SPACER		DISTANZIALE
11	79025801	74	95B BUSHING		BOCCOLA
12	79025802	2	95B BUSHING		BOCCOLA
13	79025810	2	97C TRACK CHAIN - ASSEMBLY		CATENARIA - COMPLETO
14	79026831	2	97C TRACK CHAIN - ASSEMBLY		CATENARIA - COMPLETO
15	79026832	76	295S SHOE		SUOLA
16	79039610	74	80P PIN		PERNO

TRACK - CINGOLO - CHENILLE - RAUPENKETTE - ORUGA

D3.40

N.T.R. 191 - 20.02.1990

604.01.081.04

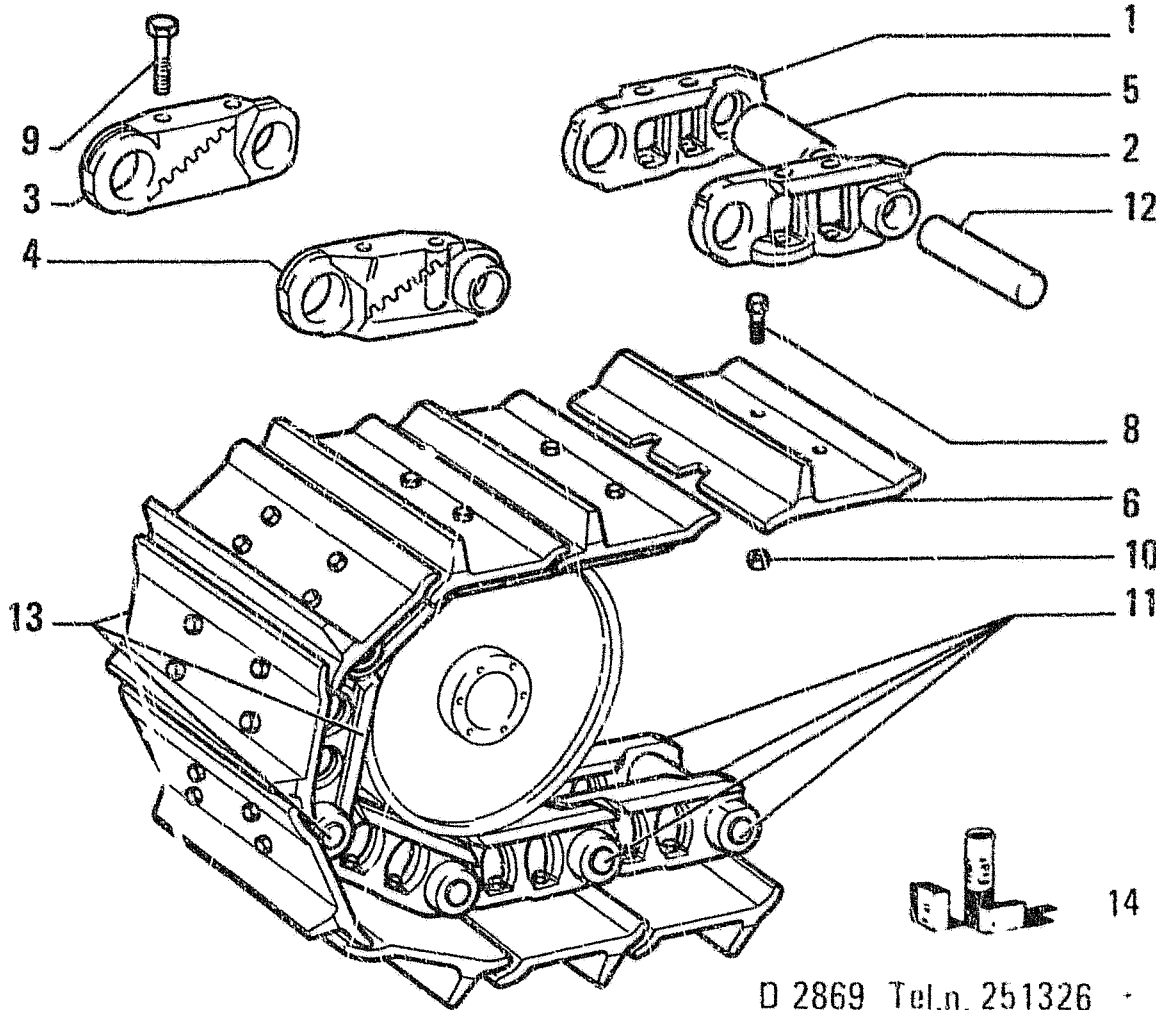

ITEM	PART NUMBER	QTY	TRANS CODE	DESCRIPTION	DESCRIZIONE
1	79086895	37	145M	TRACK LINK - RIGHT	MAGLIA CINGOLO - DESTRO
2	79086894	37	145M	TRACK LINK - LEFT	MAGLIA CINGOLO - SINISTRO
3	79086896	1	145M	TRACK LINK - RIGHT	MAGLIA CINGOLO - DESTRO
4	79086897	1	145M	TRACK LINK - LEFT	MAGLIA CINGOLO - SINISTRO
5	79089109	38	95B	BUSHING	BOCCOLA
6	79026832	38	295S	SHOE (450MM)	SUOLA (450MM)
	79026835	38	295S	SHOE (500 MM)(1*)	SUOLA (500 MM)(1*)
8	76008353	148	40V	SCREW	VITE
9	76015201	2	40V	SCREW (55MM)	VITE (55MM)
	76015987	2	40V	SCREW (85MM)	VITE (85MM)
10	76008354	148	10D	NUT	DADO
11	79089081	2	97C	TRACK CHAIN - ASSEMBLY	CATENARIA - COMPLETO
12	79089110	38	80P	PIN	PERNO
13	76015787	2	97C	TRACK CHAIN - ASSEMBLY (450MM)	CATENARIA - COMPLETO (450MM)
	76015788	2	97C	TRACK CHAIN - ASSEMBLY (500MM)	CATENARIA - COMPLETO (500MM)
14	76015040	2	1K	KIT SEE PAGE 9 (500MM)	KIT VED. PAG.9 (500MM)
	76015041	2	1K	KIT SEE PAGE 9 (450MM)	KIT VED. PAG.9 (450MM)
(1*)			469P	FOR SPECIAL EQUIPMENT 30.0530.16.1	PER VARIANTE 30.0530.16.1

D 2869 Tel.n. 251326

TRACK - CINGOLO - CHENILLE - RAUPENKETTE - ORUGA

D3.40/A 1
 N.T.R. 191 - 20.02.1990
 604.01.081.04

N7

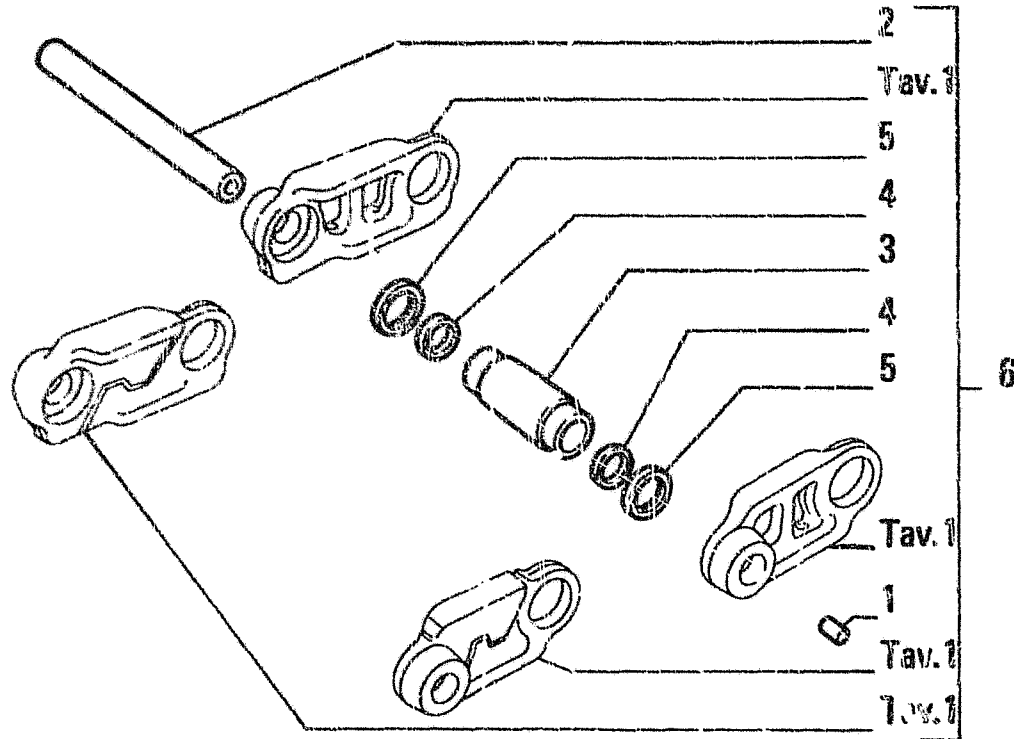

ITEM	PART NUMBER	QTY	TRANS CODE	DESCRIPTION	DESCRIZIONE
1	79086902	38	50T	PLUG (*)	TAPPO (*)
2	79086998	38	80P	PIN (*)	PERNO (*)
3	79086899	38	95B	BUSHING (*)	BOCCOLA (*)
4	79086900	76	75D	SPACER (*)	DISTANZIALE (*)
5	79086901	76	122G	SEAL (*)	GUARNIZIONE (*)
6	79086892	1	97C	TRACK CHAIN - ASSEMBLY (*)	CATENARIA - COMPLETO (*)
7	76015040	2	1K	KIT SEE PAGE 9 (500MM)	KIT VED. PAG.9 (500MM)
	76015041	2	1K	KIT SEE PAGE 9 (450MM)	KIT VED. PAG.9 (450MM)
				469P FOR SPECIAL EQUIPMENT	PER VARIANTE 30.0505.16.1
				30.0505.16.1	

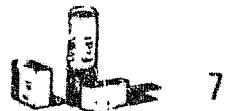

D 2869 Tel.n. 251326

TRACK - CINGOLO - CHENILLE - RAUPENKETTE - ORUGA

D3.40/A

2

N.T.R. 191 - 20.02.1990

604.01.081.04

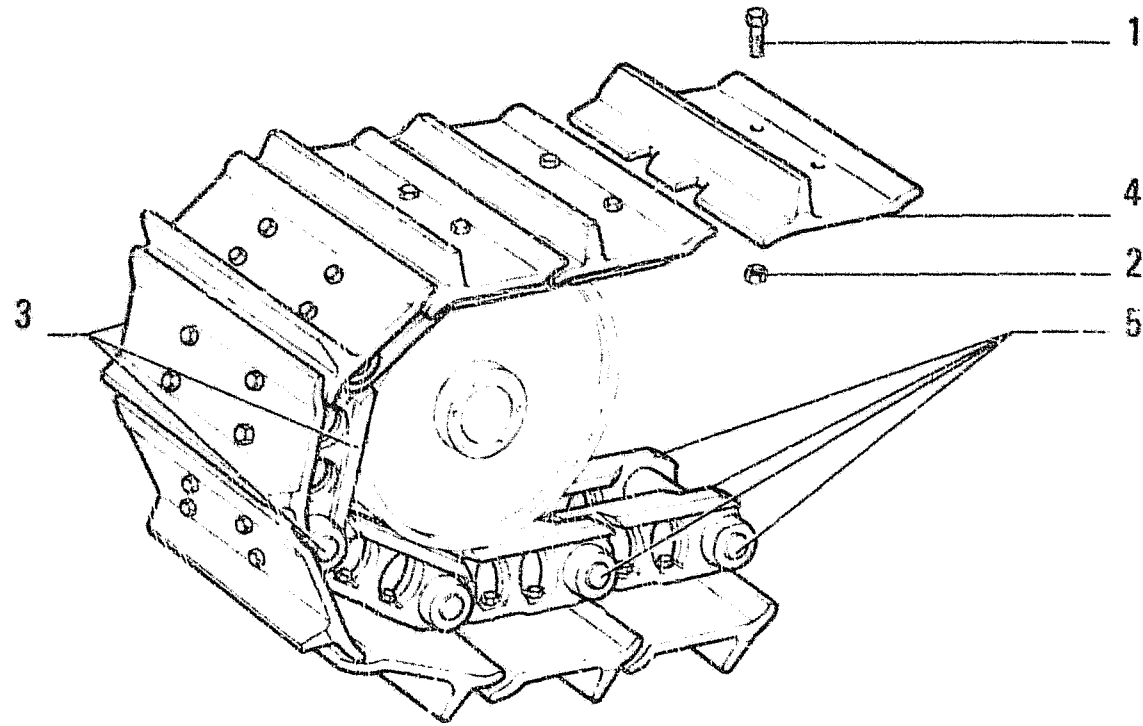

ITEM	PART NUMBER	QTY	TRANS CODE	DESCRIPTION	DESCRIZIONE
1	76008353	304	40V	SCREW D1508	VITE D1508
	79012420	304	40V	SCREW C1100	VITE C1508
2	76008354	304	10D	NUT D1508	DADO D1508
	79012421	304	10D	NUT C1508	DADO C1508
3	79026834	2	97C	TRACK CHAIN - ASSEMBLY	CATENARIA - COMPLETO
4	79026835	76	295S	SHOE 500	SUOLA 500
5	79026836	2	97C	TRACK CHAIN - ASSEMBLY	CATENARIA - COMPLETO

OPTIONAL
VARIANTE

30.0530.08.1

C 2869 → Tel.n. 251325

TRACK - CINGOLO - CHENILLE - RAUPENKETTE - ORUGA

D3.40/1

N.T.R. 191 - 20.02.1990

604.01.081.04

NO

PARTS MARKED * ARE NOT SUPPLIED AS SPARES
 I PARTICOLARI CONTRASSEGNA TI CON * NON
 VENGONO FORNITI DI RICAMBIO

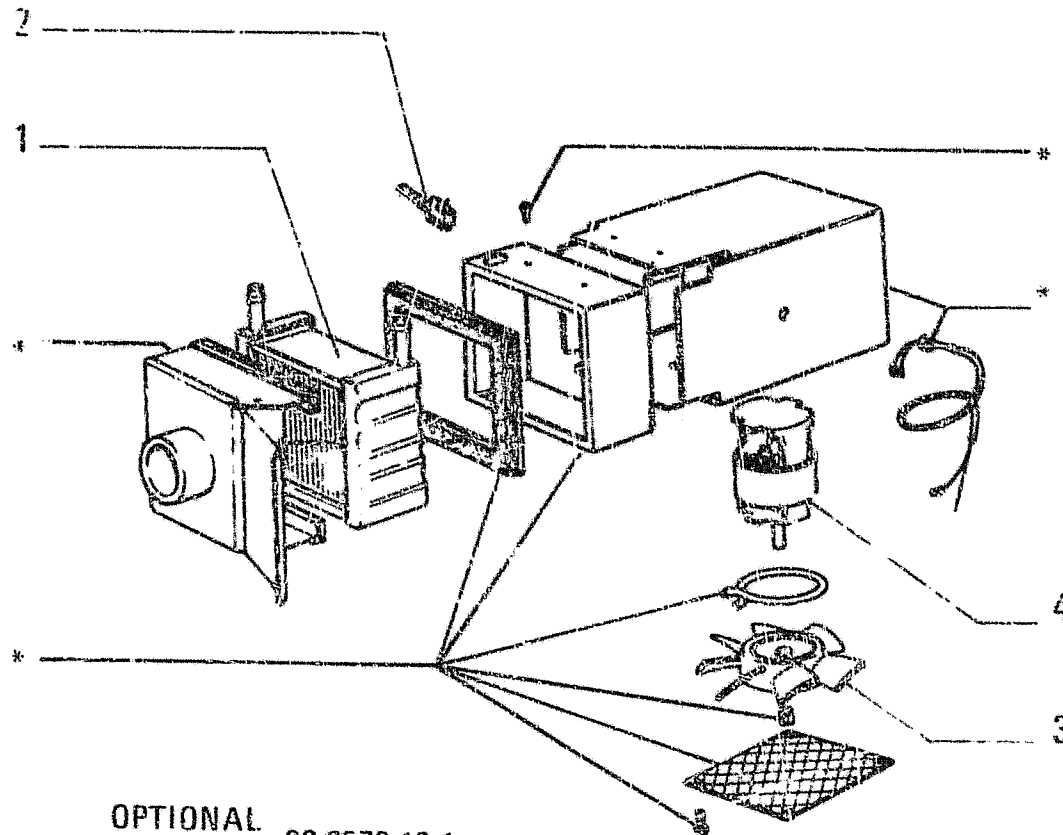

OPTIONAL
 VARIANTE 30.0570.18.1

ITEM	PART NUMBER	QTY	TRANS CODE	DESCRIPTION	DESCRIZIONE
1	9926025	1	60N	CORE	NUCLEO
2	9926027	1	75I	SWITCH	INTERRUTTORE
3	9926031	1	36V	BLOWER	VENTOLA
4	9926033	1	134M	MOTOR	MOTORINO

79043354

HEATER - RISCALDATORE - RECHAUFFEUR - HEIZGERAET - CALORIFERO

E1.02

N.T.R. 200 - 15.10.1990

604.01.081.05

N10

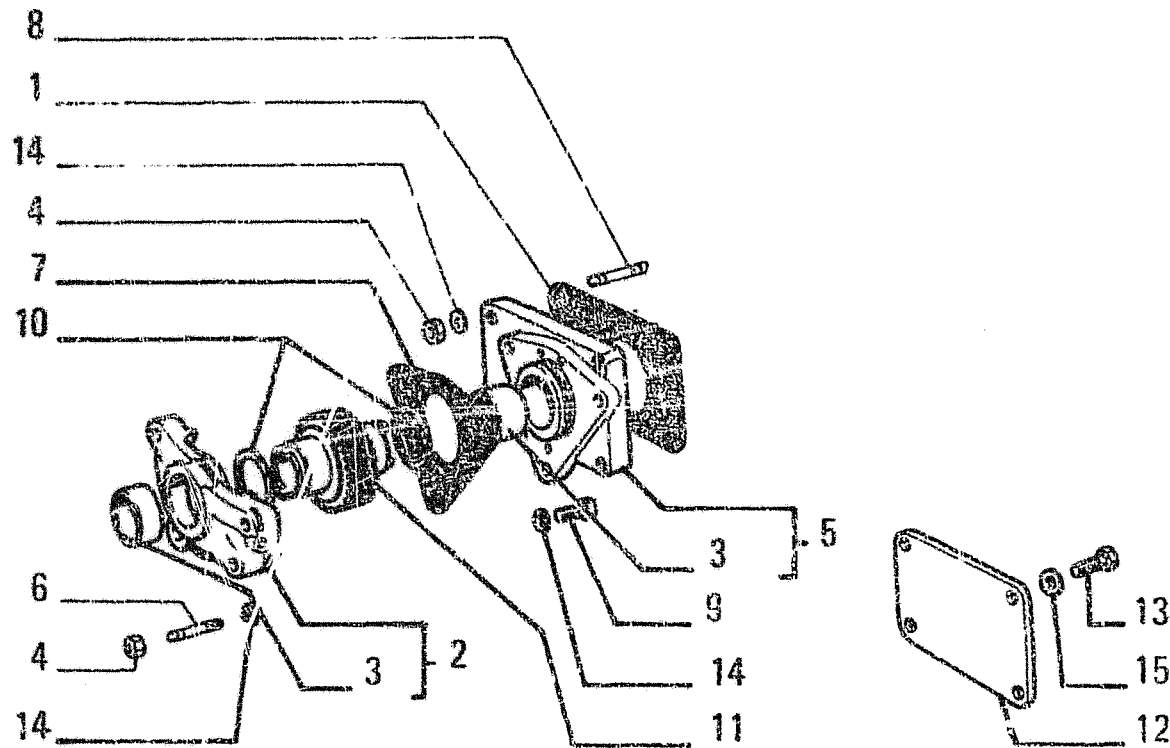

ITEM	PART NUMBER	QTY	TRANS CODE	DESCRIPTION	DESCRIZIONE
1	4607590	1	122G	SEAL 03041	GUARNIZIONE 03041
	4858082	1	122G	SEAL 03041	GUARNIZIONE 03041
2	4771242	1	300S	SUPPORT - ASSEMBLY	SUPPORTO - COMPLETO
3	4788086	1	95B	BUSHING	BOCCOLA
4	16100811	4	10D	NUT 8x1,25x6,5	DADO 8x1,25x6,5
5	4788084	1	300S	SUPPORT - ASSEMBLY	SUPPORTO - COMPLETO
6	13543620	3	210P	STUD 8x1,25x46	PRIGIONIERO 8x1,25x46
7	4619405	1	122G	SEAL 03341	GUARNIZIONE 03341
	4858091	1	122G	SEAL 03341	GUARNIZIONE 03341
8	13543621	1	210P	STUD 8x1,25x46	PRIGIONIERO 8x1,25x46
9	16044521	2	40V	SCREW 6x1,25x65	VITE 6x1,25x65
10	4667452	2	131R	WASHER	ROSETTA
11	4784432	1	50I	GEAR	INGRANAGGIO
12	564530	1	265C	COVER	COPERCHIO
13	10902321	4	40V	SCREW 6x1x18	VITE 6x1x18
14	11193871	6	131R	WASHER 8,4x16	ROSETTA 8,4x16
15	11197771	4	131R	WASHER 6,4x12	ROSETTA 6,4x12

D 1572 Tel. n. 250905 →

PTO CONTROL — COMANDO PRESA DI FORZA — COMMANDE DE PRISE DE FORCE — SHALTUNG DER
ZAPFWELLE — MANDO DE TOMA DE FUERZA

2

E2.15

N T R 206 15 10 1990

604 01.081 05

N11

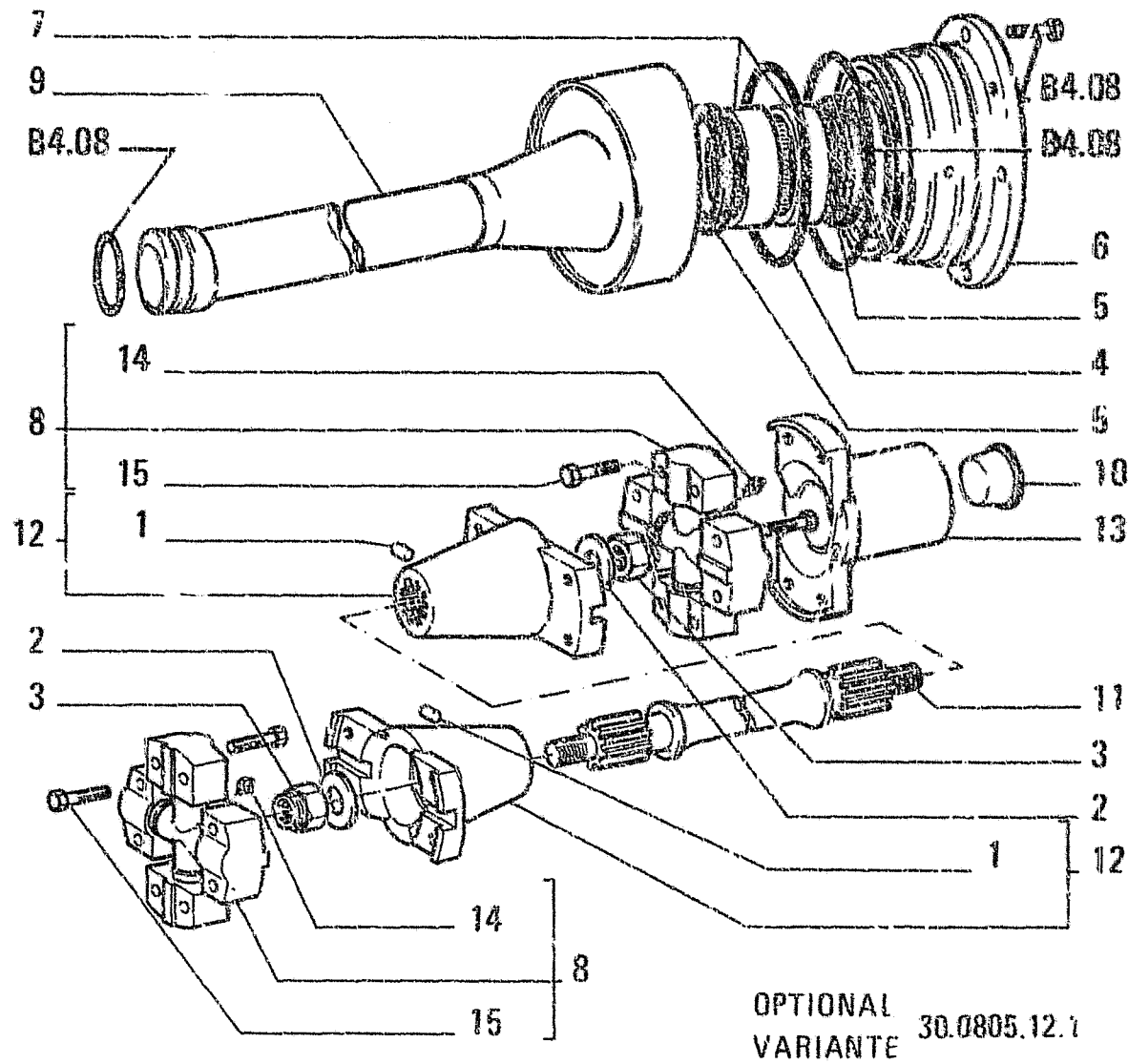

ITEM	PART NUMBER	QTY	TRANS CODE	DESCRIPTION	DESCRIZIONE
1	10839510	2	90G	DOWEL 6x9	GRAND 6x9
2	12644921	2	131R	WASHER 14,4x32	ROSETTA 14,4x32
3	14085811	2	10D	NUT 14x1,5x16,8	DADO 14x1,5x16,8
4	14466880	1	158G	O-RING 3,53x126,59	GUARNIZIONE O-R 3,53x126,59
5	40001070	2	158K	O-RING 55x75	GUARNIZIONE O-R 55x75
6	79013659	1	301S	SUPPORT	SUPPORTO
7	79014134	2	341C	BEARING	CUSCINETTO
8	79014136	2	310C	SPIDER - ASSEMBLY	CROCIERA - COMPLETO
9	79014143	1	724P	SHIELD	PROTEZIONE
10	79014182	1	50T	PLUG	TAPPO
11	79024575	1	16A	SHAFT	ALBERO
12	79036637	2	30M	SLEEVE - ASSEMBLY	MANICOTTO - COMPLETO
13	79036638	1	30M	SLEEVE - REAR	MANICOTTO - POSTERIORE
14	13407211	2	60I	GREASE FITTING 10x1	INGRASSATORE 10x1
15	79027688	16	40V	SCREW	VITE

POWER TAKE-OFF — PRESA DI FORZA — PRISE DE FORCE — ZAPFWELLE — TOMA DE FUERZA

1

E2.16

N.T.R. 158 13.03.1987
604.01.081.03

N12

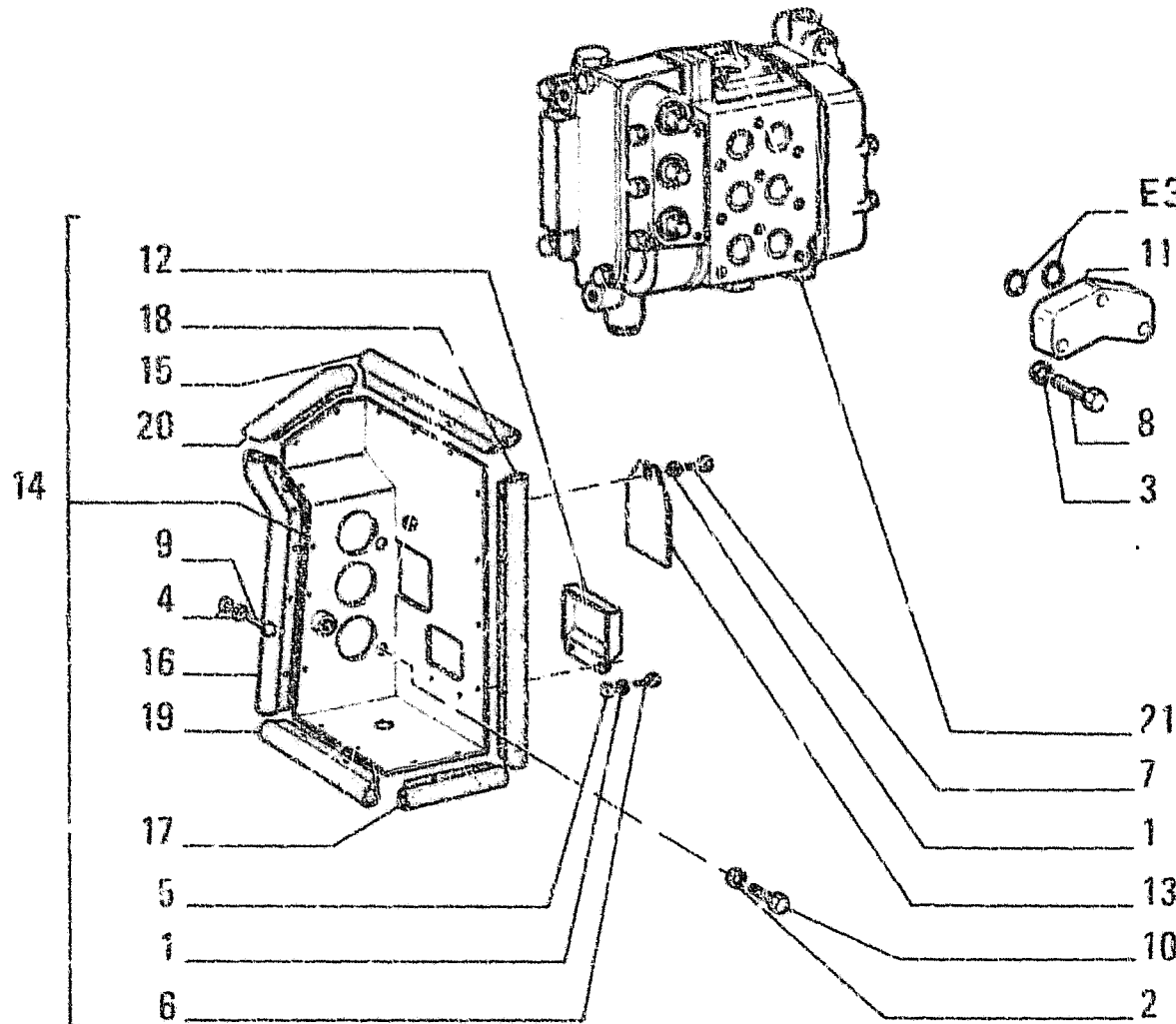

ITEM	PART NUMBER	QTY	TRANS CODE	DESCRIPTION	DESCRIZIONE
1	10516471	3	132R	LOCKWASHER 6,1x1,8	ROSETTA D' SICUREZZA 6,1x1,8
2	10516671	2	132R	LOCKWASHER 8,1x2,2	ROSETTA DI SICUREZZA 8,1x2,2
3	10516871	3	132R	LOCKWASHER 10x2,5	ROSETTA DI SICUREZZA 10x2,5
4	10519201	34	131R	WASHER 4,15x9	ROSETTA 4,15x9
5	10725911	2	10D	NUT 6x1x4	DADO 6x1x4
6	10902021	2	40V	SCREW 6x1x12	VITE 6x1x12
7	10902131	1	40V	SCREW 6x1x14	VITE 6x1x14
8	11108431	3	40V	SCREW 10x1,5x110	VITE 10x1,5x110
9	13866050	17	55R	RIVET 4x14	RIBATTINO 4x14
10	16043231	2	40V	SCREW 8x1,25x16	VITE 8x1,25x16
11	79014634	1	70F	FLANGE	FLANGIA
12	79014712	1	95S	CASE	SCATOLA
13	79024045	1	265C	COVER	COVERCHIO
14	79027502	1	70P	GUARD - ASSEMBLY	RIPARO - COMPLETO
15	79027503	1	123G	SEAL ASSY	GUARNIZIONE TENUTA FRONTALE
16	79027504	1	123G	SEAL ASSY	GUARNIZIONE TENUTA FRONTALE
17	79027505	1	123G	SEAL ASSY	GUARNIZIONE TENUTA FRONTALE
18	79027506	1	123G	SEAL ASSY	GUARNIZIONE TENUTA FRONTALE
19	79027507	1	123G	SEAL ASSY	GUARNIZIONE TENUTA FRONTALE
20	79028256	1	123G	SEAL ASSY	GUARNIZIONE TENUTA FRONTALE
21	79027108	1	83D	CONTROL VALVE - ASSEMBLY CORRECT SEE SGR. E3.31 D1159	DISTRIBUTORE - COMPLETO CORRIGE VEDERE SGR. E3.31 D1159
	79031722	1	83D	CONTROL VALVE - ASSEMBLY WRONG	DISTRIBUTORE - COMPLETO ERRATA
	79041699	1	83D	CONTROL VALVE - ASSEMBLY SEE SGR. E3.31 D1159	DISTRIBUTORE - COMPLETO VEDERE SGR. E3.31 D1159

HYDRAULIC SYSTEM - IMPIANTO IDRAULICO - SYSTEME HYDRAULIQUE - HYDRAULIKANLAGE - SISTEMA HIDRAULICO

E3.02

1

N.T.R. 191 - 20.02.1990

604.01.081.04

N13

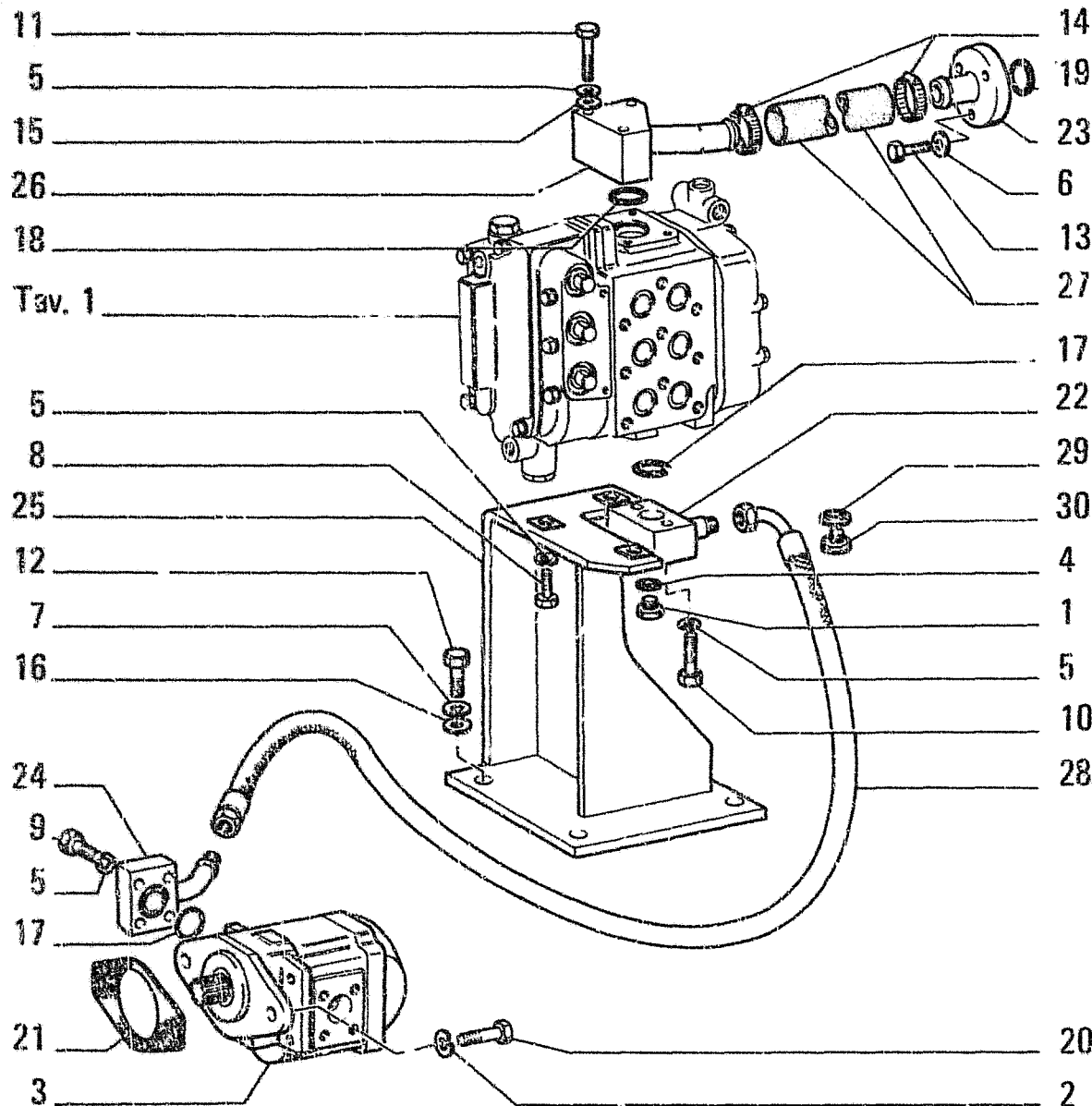

FIATALLIS FD7

E3.02 TAV. 2 PAG.1

ITEM	PART NUMBER	QTY	TRANS CODE	DESCRIPTION	DESCRIZIONE
1	581658	1	50T	PLUG C1164	TAPPO C1164
	10300571	1	50T	PLUG 12x1,5x8 D1164	TAPPO 12x1,5x8 D1164
2	584747	2	132R	LOCKWASHER	ROSETTA DI SICUREZZA
3	8297172	1	153P	OIL PUMP - ASSEMBLY SEE SGR. E3.20	POMPA OLIO - COMPLETO VEDERE SGR. E3.20
4	10260060	1	133R	SEAL 8,2x14 C1164	ROSETTA DI TENUTA 8,2x14 C1164
	10296160	1	133R	SEAL 12,2x18 D1164	ROSETTA DI TENUTA 12,2x18 D1164
5	10516871	12	132R	LOCKWASHER 10x2,5	ROSETTA DI SICUREZZA 10x2,5
6	10517071	3	132R	LOCKWASHER 12,2x3,1	ROSETTA DI SICUREZZA 12,2x3,1
7	10571970	4	132R	LOCKWASHER 12,2x2,5	ROSETTA DI SICUREZZA 12,2x2,5
8	11106231	3	40V	SCREW 10x1,5x25	VITE 10x1,5x25
9	11107331	4	40V	SCREW 10x1,5x55	VITE 10x1,5x55
10	11107531	2	40V	SCREW 10x1,5x65	VITE 10x1,5x65
11	11108031	3	40V	SCREW 10x1,5x90	VITE 10x1,5x90
12	11112431	4	40V	SCREW 12x1,75x30	VITE 12x1,75x30
13	11113031	3	40V	SCREW 12x1,75x45	VITE 12x1,75x45
14	12174790	2	180C	COLLAR 47/67x14 C2906	COLLARE 47/67x14 C2906
	79083846	2	180C	COLLAR D2906	COLLARE D2906
15	12638621	3	131P	WASHER 10,2x18	ROSETTA 10,2x18
16	12646921	4	131P	WASHER 12,2x28	ROSETTA 12,2x28
17	14463480	2	158C	O-RING 3,53x28,17	GUARNIZIONE O-R 3,53x28,17
18	14463780	1	158C	O-RING 3,53x32,92	GUARNIZIONE O-R 3,53x32,92
19	14464380	1	158G	O-RING 3,53x47,22	GUARNIZIONE O-R 3,53x47,22
20	79016255	2	40V	SCREW	VITE
21	79016256	1	123G	SEAL ASSY	GUARNIZIONE TENUTA FRONTALE

HYDRAULIC SYSTEM - IMPIANTO IDRAULICO - SYSTEME HYDRAULIQUE - HYDRAULIKANLAGE - SISTEMA HIDRAULICO

E3.02

2

N.T.R. 191 - 20.02.1990

604.01.081.04

N14

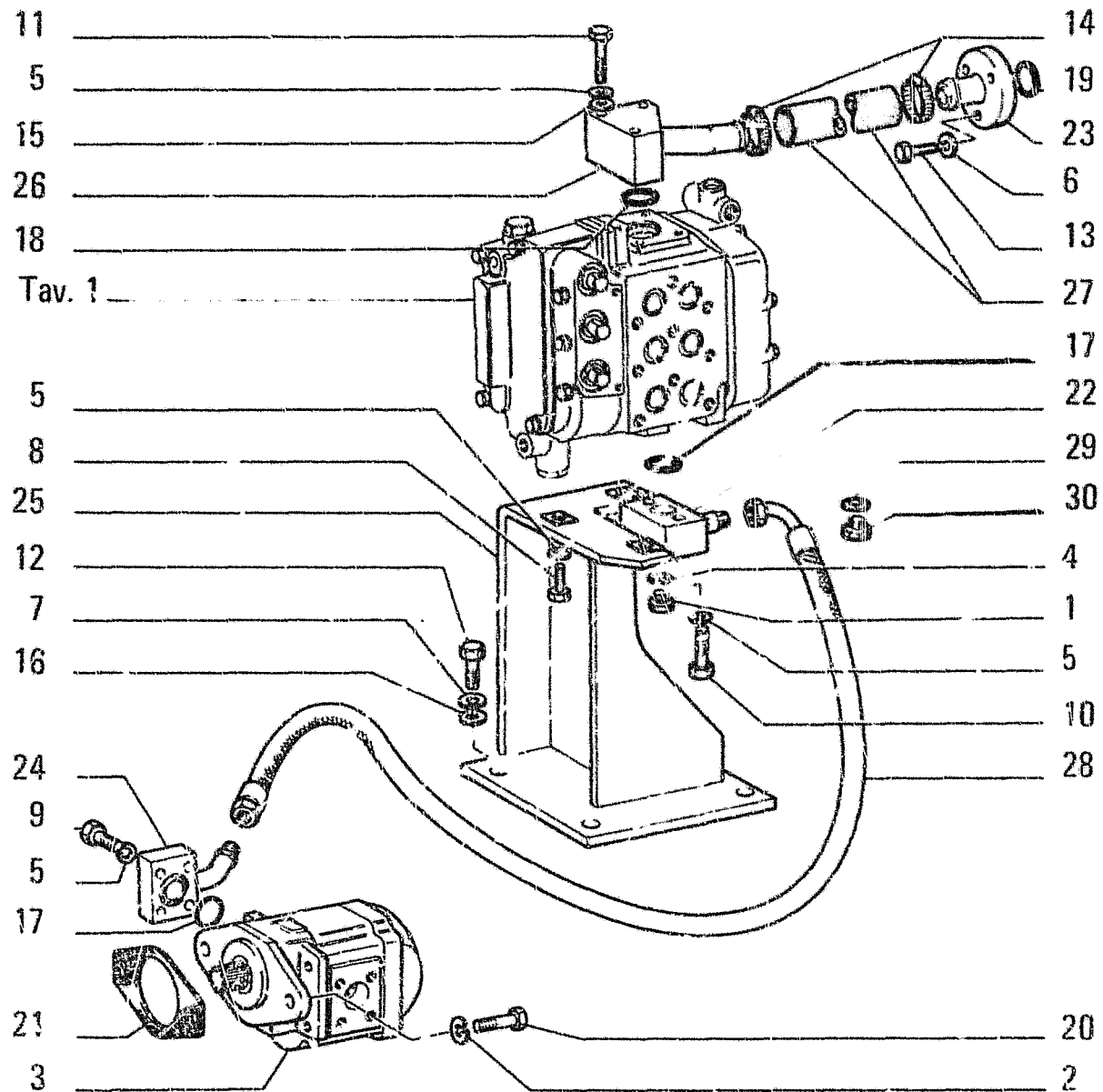

FIATALLIS FD7

E3.02 TAV. 2 PAG.2

ITEM	PART NUMBER	QTY	TRANS CODE	DESCRIPTION	DESCRIZIONE
22	79017713	1	193T	TUBE	TUBO RIGIDO
23	79017723	1	193T	TUBE	TUBO RIGIDO
24	79026400	1	193T	TUBE	TUBO RIGIDO
25	79027342	1	300S	SUPPORT	SUPPORTO
26	79027585	1	193T	TUBE	TUBO RIGIDO
27	76015372	L	285T	HOSE Ø.190 M Ø2906	TUBO FLESSIBILE Ø.190 M Ø2906
	79032011	1	30M	SLEEVE Ø2906	MANICOTTO Ø2906
28	79035762	1	192T	HOSE ASSY	TUBO FLESS./RACCORDI
29	10282460	1	133R	SEAL 14,2x20 Ø1164	ROSETTA DI TENUTA 14,2x20 Ø1164
30	10300671	1	50T	PLUG 14x1,5x9 Ø1164	TAPPO 14x1,5x9 Ø1164

HYDRAULIC SYSTEM - IMPIANTO IDRAULICO -- SYSTEME HYDRAULIQUE -- HYDRAULIKANLAGE - SISTEMA HIDRÁULICO

E3 02 2
 N.T.R. 191 - 20.02.1990
 604.01.081.04

N15

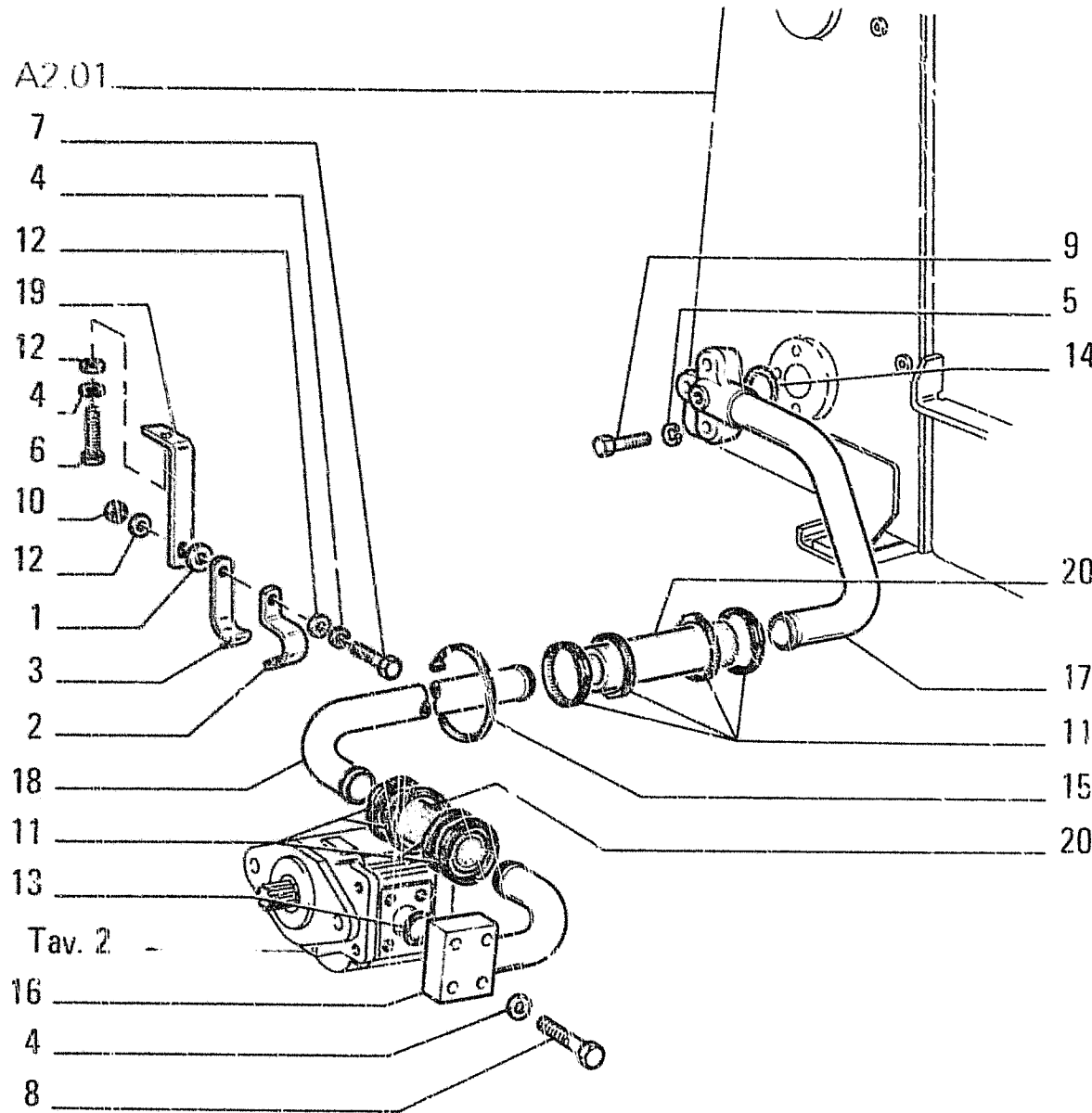

ITEM	PART NUMBER	QTY	TRANS CODE	DESCRIPTION	DESCRIZIONE
1	4967724	1	131R	WASHER	ROSETTA
2	4986079	1	231S	CLIP - UPPER	STAFFETTA - SUPERIORE
3	4986080	1	231S	CLIP - LOWER	STAFFETTA - INFERIORE
4	10516871	6	132R	LOCKWASHER 10x2,5	ROSETTA DI SICUREZZA 10x2,5
5	10517071	3	132R	LOCKWASHER 12,2x3,1	ROSETTA DI SICUREZZA 12,2x3,1
6	11106031	:	40V	SCREW 10x1,5x20	VITE 10x1,5x20
7	11106431	1	40V	SCREW 10x1,5x30	VITE 10x1,5x30
8	11107731	4	40V	SCREW 10x1,5x75	VITE 10x1,5x75
9	11113431	3	40V	SCREW 12x1,75x60	VITE 12x1,75x60
10	11701721	1	10D	NUT 10x1,5x8	DADO 10x1,5x8
11	12174790	8	180C	COLLAR 47/67x14 C2906	COLLARE 47/67x14 C2906
	79083846	4	180C	COLLAR D2906	COLLARE D2906
12	12648821	3	131P	WASHER 10,2x25	ROSETTA 10,2x25
13	14463980	1	158G	O-RING 3,53x36,09	GUARNIZIONE O-R 3,53x36,09
14	14464380	1	158G	O-RING 3,53x47,22	GUARNIZIONE O-R 3,53x47,22
15	4982514	2	31F	CLAMP D1167	FASCETTA D1167
	79001971	2	31F	CLAMP C1167	FASCETTA C1167
16	79026395	1	193T	TUBE	TUBO RIGIDO
17	79026397	1	193T	TUBE	TUBO RIGIDO
18	79026399	1	193T	TUBE	TUBO RIGIDO
19	79026402	1	225S	BRACKET	STAFFA
20	76015624	L	285T	HOSE 0,350M D2906	TUBO FLESSIBILE 0,350M D2906
	79032009	2	30M	SLEEVE C2906	MANICOTTO C2906

HYDRAULIC SYSTEM - IMPIANTO IDRAULICO - SYSTEME HYDRAULIQUE - HYDRAULIKANLAGE - SISTEMA HIDRÁULICO

E3.02

3

N.T.R. 191 - 20.02.1990

604.01.081.04

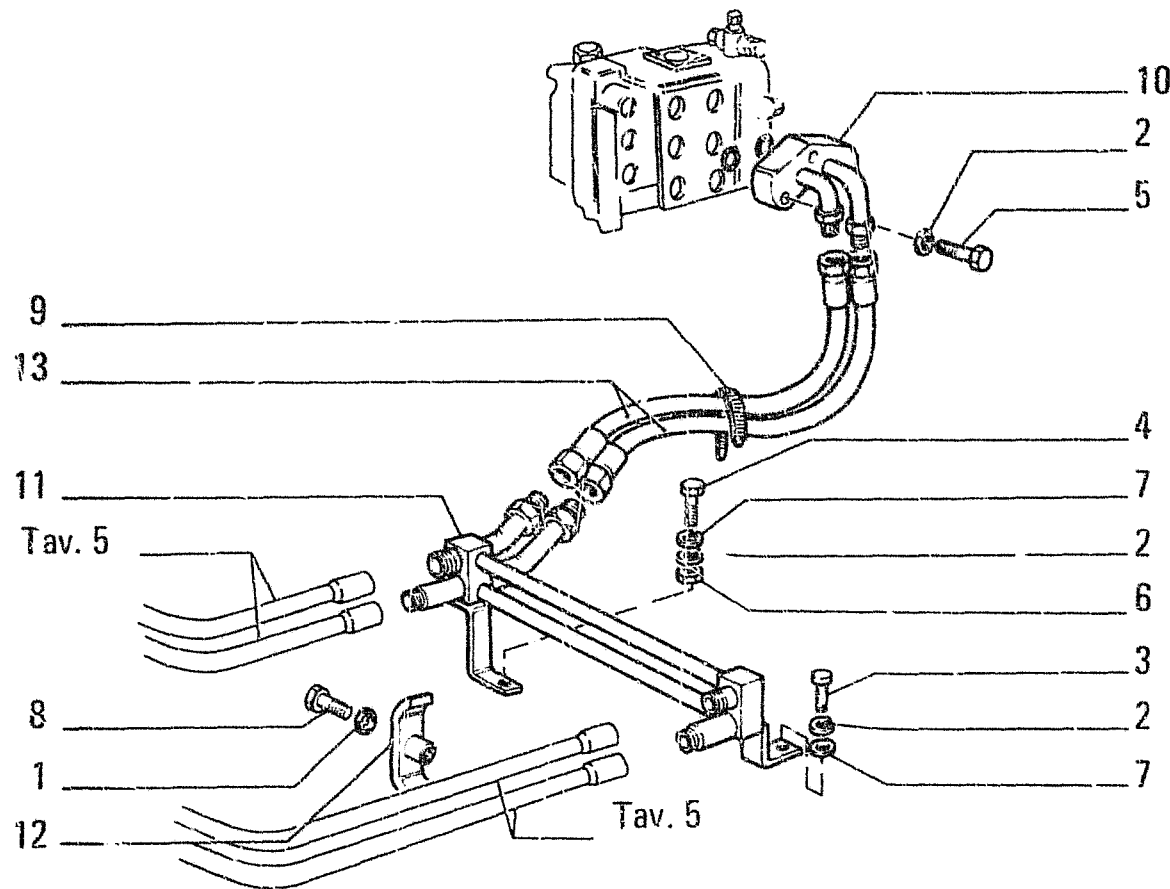

C1616 → tel. n. 250851

ITEM	PART NUMBER	QTY	TRANS CODE	DESCRIPTION	DESCRIZIONE
1	10516671	2	132R	LOCKWASHER 8,1x2,2	ROSETTA DI SICUREZZA 8,1x2,2
2	10516871	8	132R	LOCKWASHER 10x2,5	ROSETTA DI SICUREZZA 10x2,5
3	11106331	1	40V	SCREW 10x1,5x28	VITE 10x1,5x28
4	11106631	1	40V	SCREW 10x1,5x35	VITE 10x1,5x35
5	11107031	6	40V	SCREW 10x1,5x45	VITE 10x1,5x45
6	11701721	1	10D	NUT 10x1,5x8	DADO 10x1,5x8
7	12646821	2	131R	WASHER 10,2x25	ROSETTA 10,2x25
8	16044131	2	40V	SCREW 8x1,25x45	VITE 8x1,25x45
9	79001971	1	31F	CLAMP	FASCETTA
10	79021203	1	190T	LINE - REAR	TUBAZIONE - POSTERICRE
11	79021617	1	190T	LINE	TUBAZIONE
12	79028166	2	225S	BRACKET	STAFFA
13	79035754	2	192T	HOSE ASSY	TUBO FLESS.C/RACCORDI

HYDRAULIC SYSTEM — IMPIANTO IDRAULICO — SYSTEME HYDRAULIQUE — HYDRAULIKANLAGE
 SISTEMA HIDRAULICO

E3.02

4

N.T.R. 158 - 13.03.1987

604.01.081.03

N17

DESIGNAZIONE BASE	BASIC DESIGNATION	DESIGNATIONS-BASES	GRUNDBEZEICHNUNGEN	DENOMINACIONES BASE	
287C	COPPIA DI INGRANAGGI	GEAR SET	COUPLE D'ENGRENA- GES	ZAHNRAOFAAR	PAR DE ENGRANAJES
287C					
288T	TELAIO ANTERIORE	FRONT MAIN FRAME	CHASSIS AVANT	RAHMEN VORN	ARMAZON DELANTERO
287T	TELAIO POSTERIORE	REAR MAIN FRAME	CHASSIS ARRIERE	RAHMEN HINTER	ARMAZON TRASERO
288S	STRUMENTO MULTIPLO	INSTRUMENT CLUSTER	COMBINE DE BORD PLUS INDICAT	KOMBIINSTRUMENT	QUADRO DE INDICACIONES MU.
288T	TROMBA ACUSTICA	PROJECTOR	TROMPETTE	TROMPETE	TROMPETA
289T	TRATTORE	TRACTOR	TRACTEUR	MASCHINE	TRACTOR
29G1	COMANDI ESTERNI CAMBIO	TRANSMISSION OUTSIDE CONTROL	COMMANDES EXTER BOITE VITESSE	AEUSSERE GETRIEBESCHALTUNG	VARRILAJE CAMBIO VELOCIDADES
29G2	COMANDI ESTERNI RIDUTTORE	LOW SPEED OUTER CONTROLS	COMMANDES EXTER REDUCTEUR	ZUSATZGETRIEBESCHALTUNG	MANDO DEL REDUCTOR DEL CAMBIO
29G3	DISPOSITIVI SICUREZZA CAMBIO	TRANSMISSION SAFETY DEVICE	BLOCAGE DE BOITE DE VITESSES	GETRIEBESCHALTSPERRE	ENCLAVAMIENTO DEL CAMBIO
290C	COPRIGIUNTO	FISHPLATE	COUVRE-JOINT	LASCHE	CUBREJUNTAS
290T	TUBETTO IDENTIFIC.CAVI	CABLE IDENTIF.TUBE			
291C	COPRIGUARNIZIONE	SEAL COVER	COUVRE-JOINT	HALTER	ABRAZADERA
291T	TORQUE CONTROL	TORQUE CONTROL			
292C	COPRIPEDALE DI GOMMA	PEDAL RUBBER PAD	GARNITURE CADUTOUC	FUSSHEBELUEBERZUG	FORRO DE CAUCHO
293C	COPRITAPPO	PLUG COVER	CACHE-BOUCHON	SCHUTZKAPPE	CAPUCHON
294S	SUCCHIERUOLA	SUCTION ROSE	CREPINE	SAUGSIEB	FILTRO DE ASP RACCION
295C	CORNICE	BEZEL	MONTURE	RAHMEN	MARCO
295S	SUOLA	SHOE	PATIN	KETTENPLATTE	ZAPATA
296C	COPRIPULSANTE	BUTTON COVER	CACHE-BOUTON	DRUCKKNOPFDECKEL	CAPUCHA
297C	CORONA DENTATA	RING GEAR	COURONNE DENTEE	ZAHNKRANZ	CORONA DENTADA
3G42	CILINDRO POSIZIONATORE	POSITIONER CYLINDER	CYLINDRE POSITION	STELLZYLINDER	
3G44	CILINDRO PENETRAZIONE	PENETRATION CYLINDER	CYLINDRE DE PENETRATION	EINDRINGZYLINDER	
300C	CORPO	BODY	CORPS	GEHAUSE	CUERPO
300S	SUPPORTO	SUPPORT	SUPPORT	TRAEGER	SOPORTE
3007	PNEUMATICI 23.5X25	TIRES 23.5X25	PNEUS 23.5X25	REIFEN 23 5X25	
301S	SUPPORTO ELASTICO	SNUBBER	SUPPORT ELASTIQUE	FEDERTRAEGER	APOYO ELASTICO
3017	PNEUMATICI 20X24	TIRES 20X24		REIFEN 20X24	
302S	SUPPORTO OSCILLANTE	SWIVELLING BLOCK	SUPPORT OSCILLANT	KIFPLAGER	APOYO OSCILANTE
304S	SUPPORTO MASSE CENTRIFUGHE	WEGHT PLATE	PLAQUE DE MASSE- LOTTE	VERSTELLPLATTE	SOPORTE DEL CON- TRAPESO
304S					
305S	SUPPORTO CON CATADIOTTRO	SUPPORT W/F FLEX REFLECTOR	SUPPORT AVEC CATA- DIOPTRE	LAGER MIT RUECK- STRAHLER	SOPORTE CON CATA- FAROS
305S					
307C	CORRETTORE	CORRECTOR	CORRECTEUR	VERSTELLER	CORRECTOR
308C	CORRETTORE DI FRENATA	BRAKE COMPENSATOR	REPARTITEUR DE FRENAGE	BREMSVERSTELLER	CORRECTOR DE FRENADO
308C					
310S	SUPPRESSORE FRENI	BRAKE BOOSTER	SURPRESSEUR DE FREINS	DRUCKVERSTELLER	REFORZADOR DE FRENO
312C	CREMAGLIERA	RACK	CREMAGLIERE	ZAHNSTANGE	REMALLERA
315C	CRISTALLO	GLASS PANE	GLACE	GLASSCHEIBE	CRISTAL
316C	CRISTALLO PROIETTORE	HEADLAMP LENS	GLACE DE PRO- JECTEUR	STREUSCHEIBE	CRISTAL DE PRO- JECTOR
316C					

DESIGNAZIONE BASE	BASIC DESIGNATION	DESIGNATIONS-BASES	GRUNDBEZEICHNUNGEN	DENOMINACIONES BASE
238P	PUNTALE	PUSH ROD	EMBOU	HERRETE
239P	PUNTELLO	STAY	BEQUILLE	PUNTAL
24G4	TUBAZIONI TRASM.IDROSTATICA	HYDROSTATIC DRIVE SYSTEM LINES		
240P	PUNTERIA	TAPPET	POUSSOIR	PERNIO ARTICULADO
241P	PUNTERIA A RULLO	ROLLER TAPPET	POUSSOIR A GALET	EMPUJADOR DE RODILLO
241P				RODILLO
242P	PUNTA DENTE RIPPER	RIPPER SHANK POINT	POINTE DENT SCARIFICATEUR	PUA DE DIEMTE RIPPER
244P	PUNTONE	STRUT	ETAI	LISTON
245C	CONTACHILOMETRI	SPEEDOMETER - KM	COMPTEUR KILOMETRIQUE	CUENTAKILOMETROS
245C				
246C	CONTAMIGLIA	SPEEDOMETER-MILES	COMPTEUR DE MILLES	CUENTAMILLAS
247C	CONTAGIRI	TACHOMETER	COMPTE-TOURS	CUENTAREVOLUCIONES
248C	CONTAGRE	HOURMETER	HOROMETRE	CUENTAHORAS
248P	PUNZONE	PUNCH	POINCON	PUNZON
25GA	INNESTO TRASMISSIONE	ENGINE/TRANSMISSION COUPLING		
25G1	COLLEGAMENTI CAMDIO	TRANSMISSION CONNECTING		
250C	CONTATTO	CONTACT	CONNECTIONS DE BOITE VITESSES	
254C	CONTENITORE	CONTAINER	CONTACT	CONTACTO
255C	CONTENITORE FILTRO	FILTER SHELL	CONTAINEUR	RECIPIENTE
257C	CONTRODADO	LOCK NUT	CUVE DE FILTRE	CAMISA DE FILTRO
259C	CONVERTITORE DI COPPIA	TORQUE CONVERTER	CONTRE-ECROU	CONTRATUERCA
260C	CONVOGLIATORE	SHROUD	CONVERTISSEUR DE COUPLE	CONVERTIDOR
265C	COPERCHIO	COVER	CONVOYEUR	CANALIZADOR
270C	COPIGLIA	COTTER PIN	COUVERCLE	TAPA
271	STATORE	STATOR	COUPILLE	CHAVETA PARTIDA
274C	COPPA OLIO	OIL SUMP	STATOR	ESTATOR
274S	STELO	ROD	CARTER A HUILE	CARTER DE ACEITE
275C	COPPA	SUMP	TIGE	VASTAGO
275S	STERZO	STEERING	CARTER A HUILE	CARTER DE ACEITE
278C	COPPA DELLA RUOTA	WHEEL CAP	DIRECTION	DIRECCION
278C			ENJOLIVEUR DE ROUE	EMBELLECEDOR DE RUEDA
279C	COPPA RACCOGLIOILIO	OIL SHIELD	COLLECTEUR	RETENEDOR DE ACEITE
279C			D'HUILE	
28G8	DISPOSITIVO LUBRIFIC.CAMRIO	TRANS.LUBRICATION SYSTEM	D'SP LUBRIFIC BOITE VITESSE	GETRIEBESCHMIERSYSTEM
280S	STOPPINO	WICK	MECHE	SCHMIERDOCHT
282T	TARGA MANUTENZIONE	SERVICE AND LUBE INSTRUCTION	DECALCOMANIE ENTRETIEN	ABZIEHBILD BETAETIGUNG WINKELS
283T	TARGHETTA IDENTIFICAZIONE	IDENTIFICATION PLATE	PLAQUETTE RECAPITULATIVE	TYPENSCHILD
284T	TERGICRISTALLO POSTERIORE	WINDSCREEN WIPER	ESSUIE-GLACE	SCHIEBENWISCHERHINTER
285C	COPPIA CONICA	BEVEL GEAR SET	COUPLE CONIQUE	TELLER UND KEGELRAD
285T	TUBO FLESSIBILE	HOSE	TUYAU FLEXIBLE	SCHLAUCH

DESIGNAZIONE BASE	BASIC DESIGNATION	DESIGNATIONS-BASES	GRUNDBEZEICHNUNGEN	DENOMINACIONES BASE
210C	COMMUTATORE	SWITCH	COMMUTEUR	CONMUTADOR
210P	PRIGIONIERO	STUD	GOIJON	ESPARRAGO
210T	TURBOCOMPRESSORE	TURBOCHARGER	TURBOCOMPRESSEUR	TURBOCOMPRESOR
211T	TUTA	OVERALL	COMBINAISON	MONO DE MECANICO
214C	COMPRENDE	INCLUDES	COMPREND	COMPRENDE
215P	PROFILATO	CHANNEL	PROFILE	PERFIL
215S	SQUADRETTA	CONNECTING PLATE	EQUERRE	ESCUADRA
216C	COMPRESSORE ARIA	AIR COMPRESSOR	COMPRESSEUR D AIR	COMPRESOR
216P	PROFILATO DI GOMMA	RUBBER SECTION	PROFILE CAOUTCHOUC	PERFIL DE GOMA
218P	PROIETTORE A TRE LUCI	THREE-LIGHT HEADLAMP	PROJECTEUR A TROIS FEUX	PROYECTOR DE TRES LUCES
226G	ROTAZIONE RETROSCAVATORE	BACKHOE ROTATION	ROTATION PELLE RETRO	ROTACION RETROEXCAVADORA
220C	CONDENSATORE	CONDENSER	CONDENSATEUR	CONDENSADOR
220P	PROIETTORE	FLOODLIGHT	PROJECTEUR	PROYECTOR
220S	STABILIZZATORE	STABILIZER	STABILISATEUR	ESTABILIZADOR
221C	CONDIZIONATORE	AIR CONDITIONER	CLIMATISEUR	CLIMATIZADOR
221P	PROIETTORE SDOPPIATO	DUAL HEADLAMP	PROJECTEUR DOUBLE	PROYECTORES GEME- LOS
221P				
222P	PROLUNGA	EXTENSION	RALLONGE	EXTENSION
223C	CONDOTTO	DUCT	CONDUIT	CONDUCTO
223P	PROLUNGA PER GONFIAGGIO	TIRE INFLATION EXTENSION	RALLONGE DE GON- FLAGE	EXTENSION DE MAN- GUERA
223P				
223P				
224C	CONDOTTO ARIA	AIR DUCT	CONDUIT D AIR	CONDUCTO DE AIRE
224P	PROTEZIONE	SHIELD	PROTECTION	DEFENSA
225C	COLLETTORE ASPIRAZIONE	INTAKE MANIFOLD	CONDUIT D ADMISSION	COLECTOR DE ASPIRACION
225S	STAFFA	BRACKET	ETRIER	ESTRIBO
226S	STAFFA AD U	U-BOLT	ETRIER PROFILE EN U	BRIDA DE SECCION EN U
226S				
236C	PEDALIERA	PEDAL CONTROL		
236S	TUBAZIONI COMANDO TRASM. IDR	TRANSMISSION CONTROL LINES		
230C	COLLETTORE DI SCARICO	EXHAUST MANIFOLD	CONDUIT D ECHAPPEMENT	COLECTOR DE ESCAPE
230P	PULEGGIA	PULLEY	POULIE	POLEA
230V	VOLTAMPEROMETRO	VOLTAMMETER	VOLTAMPEROMETRE	VOLTAMPERIMETRO
231S	STAFFETTA	CLIP	COLLIER	ABRAZADERA
231V	VERNICE	PAINT	PEINTURE	PINTURA
235C	CONNESSIONE	CONNECTION	CONNEXION	CONEXION
235S	STANTUFFO	PISTON	PISTON	EMBOLO
236P	PULSANTE	PUSH BUTTON	BOUFON	PULSADOR
237P	PULSANTIERA	SWITCH PANEL	CLAVIER	DELLADO

E

AUXILIARY ATTACHMENT (AND EQUIPMENT) • ORGANI SUSSIDIARI (E ATTREZZI) • ORGANES AUXILIAIRES (ET EQUIPEMENT) •
NEBENAGGREGATE (UND GERÄTE) • GRUPOS AUXILIARES (Y EQUIPO)

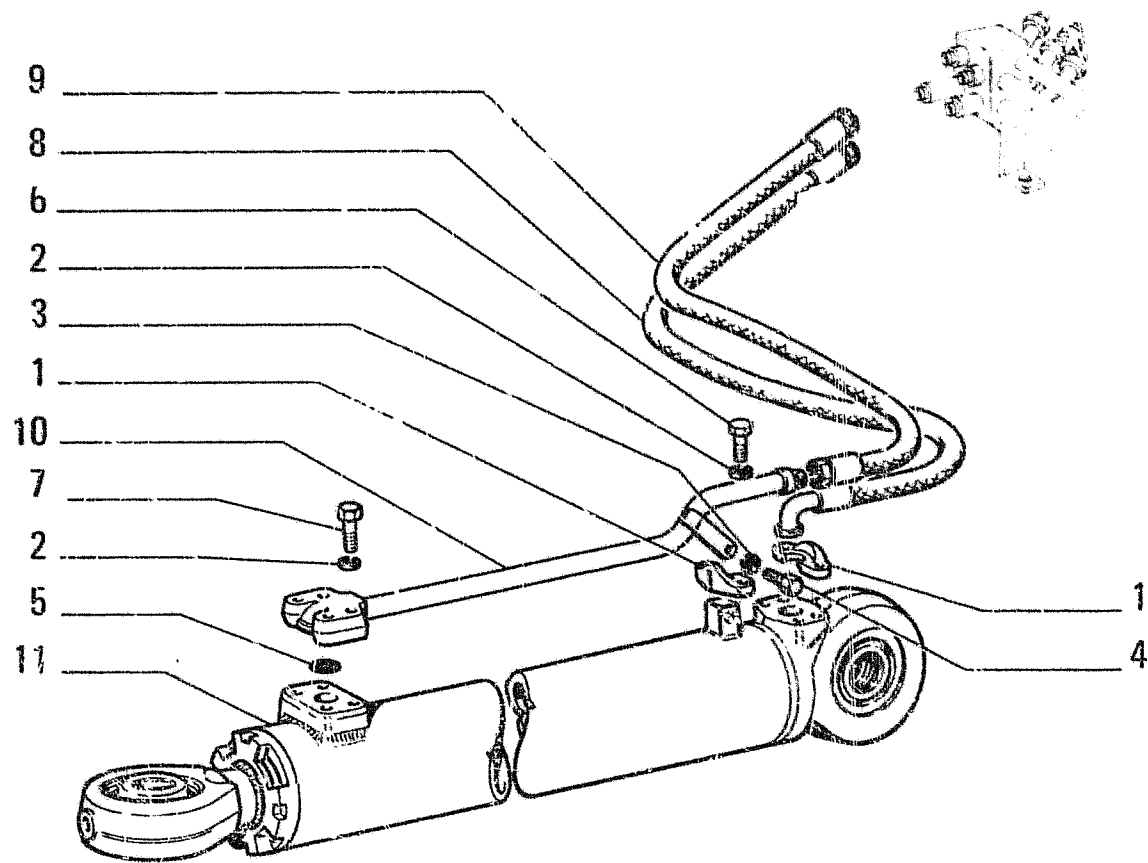

ITEM	PART NUMBER	QTY	TRANS CODE	DESCRIPTION	DESCRIZIONE
1	8297995	4	70F	FLANGE	FLANGIA
2	10516671	16	132R	LOCKWASHER 8,1x2,2	ROSETTA DI SICUREZZA 8,1x2,2
3	10516871	2	132R	LOCKWASHER 10x2,5	ROSETTA DI SICUREZZA 10x2,5
4	11106031	2	40V	SCREW 10x1,5x20	VITE 10x1,5x20
5	14457280	2	158G	O-RING 2,62x15,54	GUARNIZIONE O-R 2,62x15,54
6	16043631	8	40V	SCREW 8x1,25x25	VITE 8x1,25x25
7	16044131	8	40V	SCREW 8x1,25x45	VITE 8x1,25x45
8	79035758	2	192T	HOSE ASSY	TUBO FLESS.C/RACCORDI
9	79035764	2	192T	HOSE ASSY	TUBO FLESS.C/RACCORDI
10	79039818	2	190T	LINE	TUBAZIONE
11	79039486	2	171C	OPERATING CYLINDER - ASSEMBLY SEE SGR. E3.32/2 C1612	CILINDRO OPERATORE - COMPLETO VEDERE SGR. E3.32/2 C1612
	79047905	2	171C	OPERATING CYLINDER - ASSEMBLY SEE SGR. E3.32/2 D1612	CILINDRO OPERATORE - COMPLETO VEDERE SGR. E3.32/2 D1612

OPTIONAL 30.0127.02.1
VARIANTE

C1616 → tel. n. 250851

HYDRAULIC SYSTEM - IMPIANTO IDRAULICO - SYSTEME HYDRAULIQUE - HYDRAULIKANLAGE -
SISTEMA HIDRÁULICO

E3.02/9	2
N.T.R. 158 - 13.03.1987	
604.01.081.03	

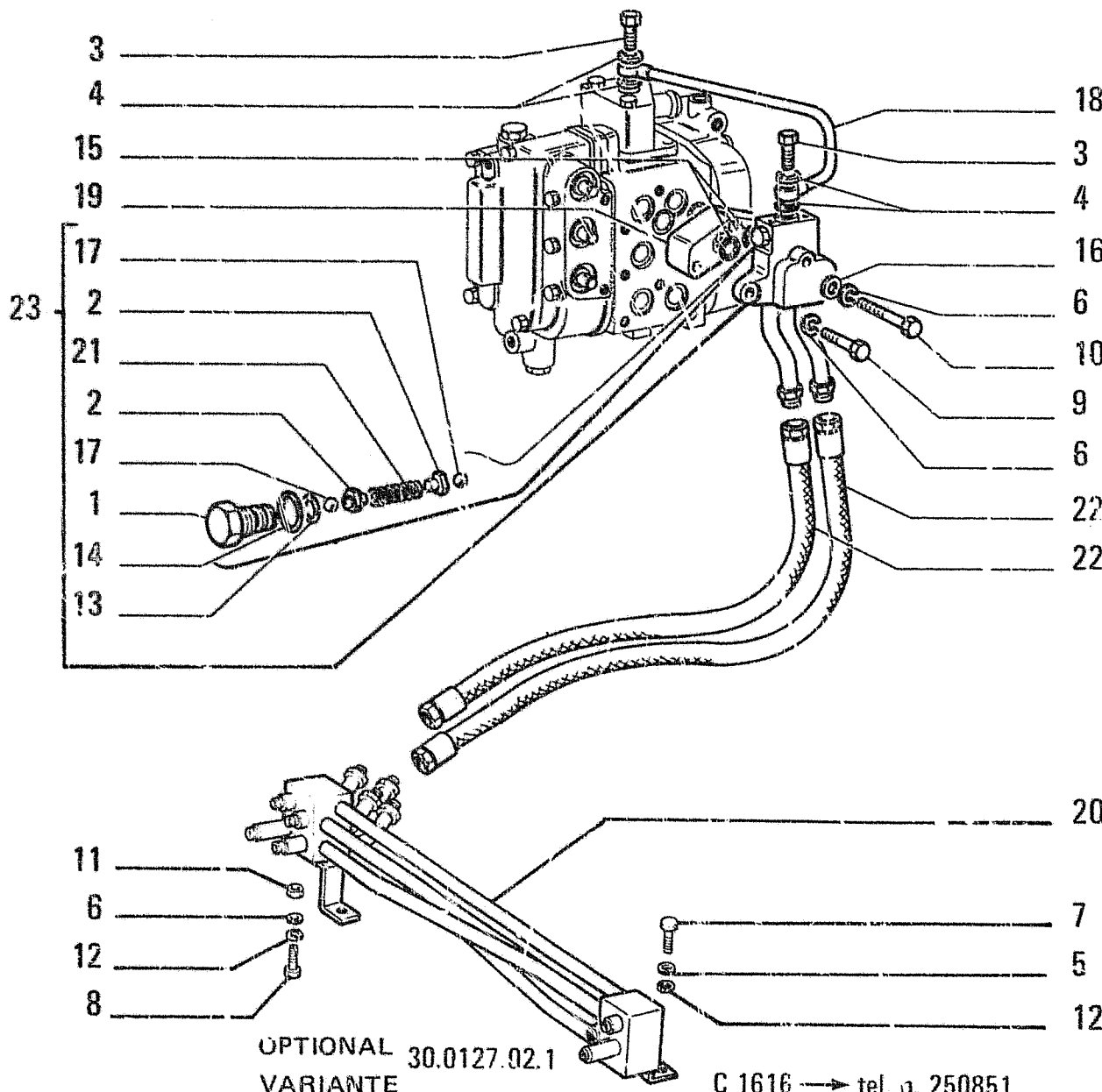

ITEM	PART NUMBER	QTY	TRANS CODE	DESCRIPTION	DESCRIZIONE
	1 8291706	1	50T	PLUG	TAPPO
	2 8291707	2	147G	SPRING GUIDE	GUIDA DELLA MOLLA
	3 10181717	2	20R	FITTING 12x1,5x11	RACCORDO 12x1,5x11
	4 10296160	4	133R	SEAL 12,2x10	ROSETTA DI TENUTA 12,2x10
	5 10516821	1	152R	LOCKWASHER 10,2x2,5	ROSETTA DI SICUREZZA 10,2x2,5
	6 10516871	4	137R	LOCKWASHER 10x2,5	ROSETTA DI SICUREZZA 10x2,5
	7 11106331	1	40V	SCREW 10x1,5x28	VITE 10x1,5x28
	8 11106631	1	40V	SCREW 10x1,5x35	VITE 10x1,5x35
	9 11108231	1	40V	SCREW 10x1,5x100	VITE 10x1,5x100
	10 11108631	2	40V	SCREW 10x1,5x120	VITE 10x1,5x120
	11 11701721	1	10D	NUT 10x1,5x8	DADO 10x1,5x8
	12 12646621	2	131R	WASHER 10,2x25	ROSETTA 10,2x25
	13 14452980	1	158G	O-RING 1,78x9,25	GUARNIZIONE O-R 1,78x9,25
	14 14457180	1	158G	O-RING 2,62x13,94	GUARNIZIONE O-R 2,62x13,94
	15 14462980	2	158G	O-RING 3,53x20,22	GUARNIZIONE O-R 3,53x20,22
	16 14496621	2	131R	WASHER 10,5x21	ROSETTA 10,5x21
	17 20063450	2	140S	BALL 6,350	SFERA 6,350
	18 79021558	1	193T	TUBE	TUBO RIGIDO
	19 79021643	1	75D	SPACER	DISTANZIALE
	20 79021644	1	190T	LINE	TUBAZIONE
	21 79022809	1	100M	SPRING	MOLLA
	22 79035754	2	192T	HOSE ASSY	TUBO FLESS.C/RACCORDI
	23 79041764	1	70F	FLANGE	FLANGIA

OPTIONAL 30.0127.02.1
VARIANTE

C 1616 → tel. n. 250851

HYDRAULIC SYSTEM – IMPIANTO IDRAULICO – SYSTEME HYDRAULIQUE – HYDRAULIKANLAGE –
SISTEMA HIDRÁULICO

E3.02/ 9

1

N.T.R. 158 - 13.03.1987
604.01.081.03

E3.02

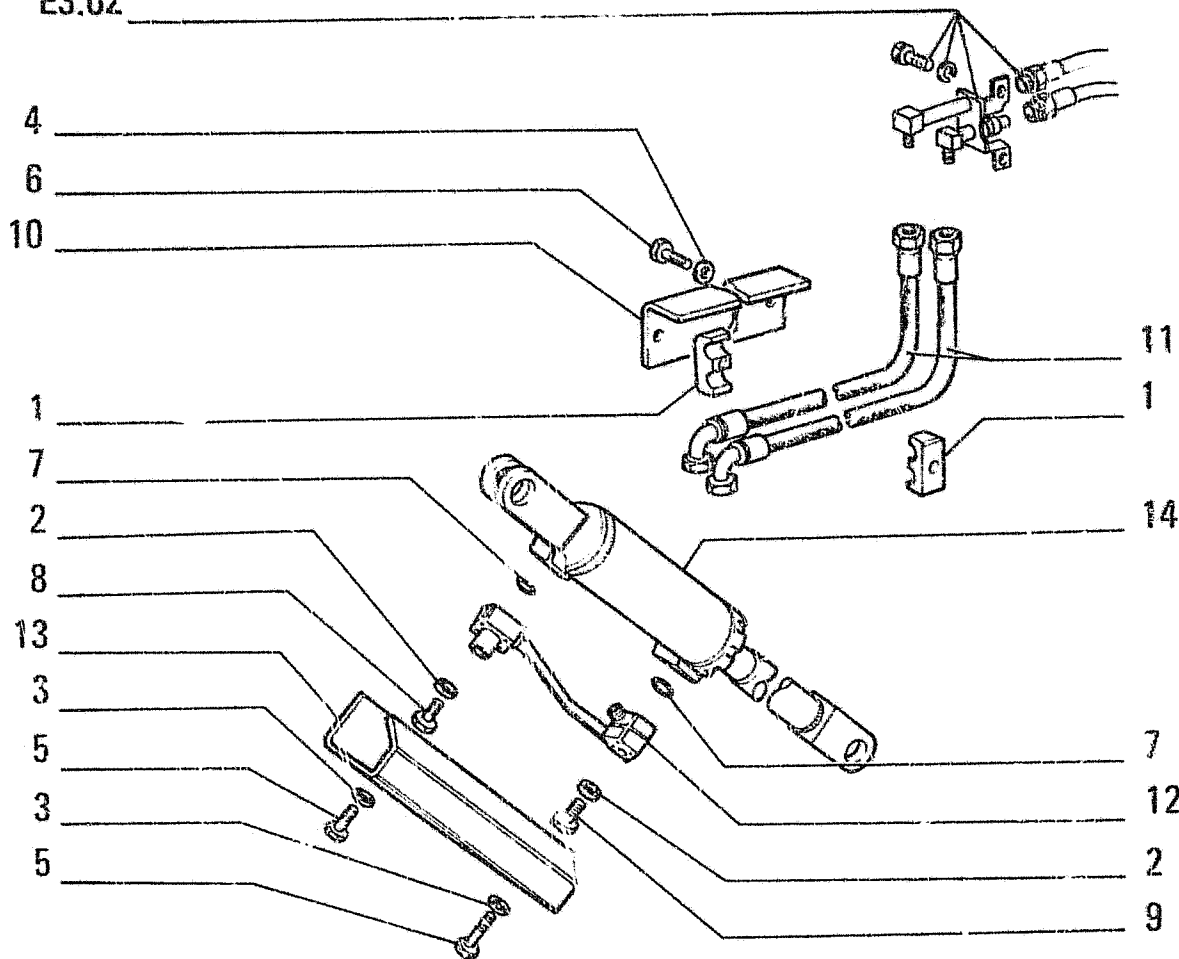

OPTIONAL
VARIANTE 30.1124.05.1

ITEM	PART NUMBER	QTY	TRANS CODE	DESCRIPTION	DESCRIZIONE
1	6284842	4	78B	FASTENING BLOCK	BLOCCETTO DI FISSAGGIO
2	10516671	8	132R	LOCKWASHER 8,1x2,2	ROSETTA DI SICUREZZA 8,1x2,2
3	10516871	2	132R	LOCKWASHER 10x2,5	ROSETTA DI SICUREZZA 10x2,5
4	10571971	2	132R	LOCKWASHER 12,2x2,5	ROSETTA DI SICUREZZA 12,2x2,5
5	11106031	2	40V	SCREW 10x1,5x20	VITE 10x1,5x20
6	11113331	2	40V	SCREW 12x1,75x55	VITE 12x1,75x55
7	14457280	2	158G	O-RING 2,62x15,54	GUARNIZIONE O-R 2,62x15,54
8	16043931	4	40V	SCREW 8x1,25x35	VITE 8x1,25x35
9	16044431	4	40V	SCREW 8x1,25x60	VITE 8x1,25x60
10	79035269	1	224P	SHIELD	PROTEZIONE
11	76010230	2	285T	HOSE D1616	TUBO FLESSIBILE D1616
	79035515	2	285T	HOSE C1616	TUBO FLESSIBILE C1616
12	76010228	1	190T	LINE D1616	TUBAZIONE D1616
	79039816	1	190T	LINE C1616	TUBAZIONE C1616
13	79040211	1	70R	GUARD	RIPARO
14	76016702	1	171C	OPERATING CYLINDER - ASSEMBLY SEE SGR. E3.32/5 D2948	CILINDRO OPERATORE - COMPLETO VEDERE SGR. E3.32/5 D2948
	79039487	1	171C	OPERATING CYLINDER - ASSEMBLY SEE SGR. E3.32/5 C1612	CILINDRO OPERATORE - COMPLETO VEDERE SGR. E3.32/5 C1612
	79047904	1	171C	OPERATING CYLINDER - ASSEMBLY SEE SGR. E3.32/5 D1612	CILINDRO OPERATORE - COMPLETO VEDERE SGR. E3.32/5 D1612
		1	171C	OPERATING CYLINDER - ASSEMBLY SEE SGR. E3.32/5 C2948	CILINDRO OPERATORE - COMPLETO VEDERE SGR. E3.32/5 C2948

HYDRAULIC SYSTEM -- IMPIANTO IDRAULICO -- SYSTEME HYDRAULIQUE -- HYDRAULIKANLAGE --
SISTEMA HIDRAULICO

E3.02/8

N.T.R. 191 - 20.02.1990

604.01.081.04

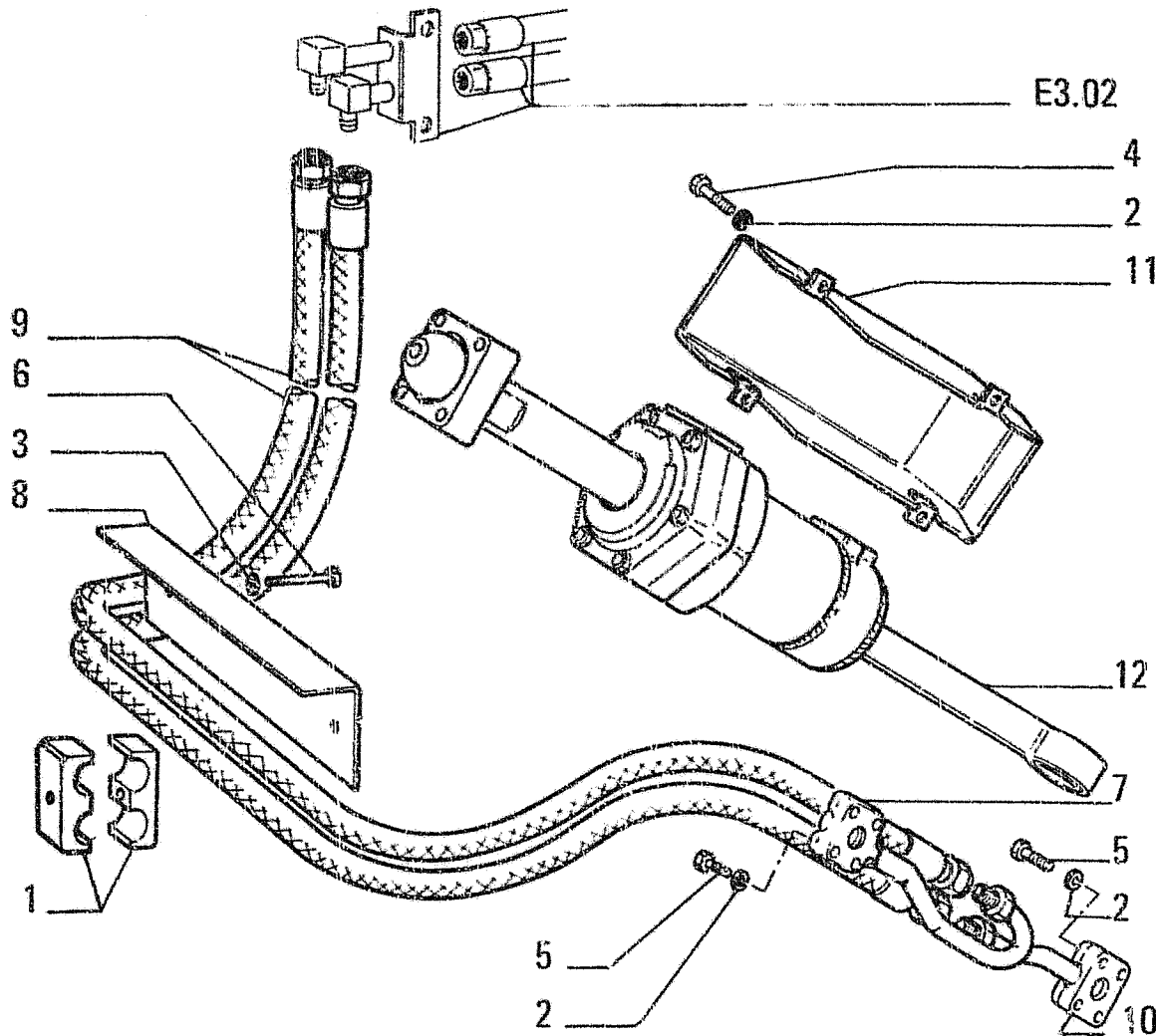

OPTIONAL
VARIANTE 30.1070.09 1

ITEM	PART NUMBER	QTY	TRANS CODE	DESCRIPTION	DESCRIZIONE
1	8287493	4	78B	FASTENING BLOCK	BLOCCETTO DI FISSAGGIO
2	10516871	12	132R	LOCKWASHER 10x2,5	ROSETTA DI SICUREZZA 10x2,5
3	10517071	2	132R	LOCKWASHER 12,2x3,1	ROSETTA DI SICUREZZA 12,2x3,1
4	11106031	4	40V	SCREW 10x1,5x20	VITE 10x1,5x20
5	11106831	8	40V	SCREW 10x1,5x40	VITE 10x1,5x40
6	11113431	2	40V	SCREW 12x1,75x60	VITE 12x1,75x60
7	79029646	1	190T	LINE - FRONT	TUBAZIONE - ANTERIORE
8	79029657	1	224P	SHIELD	PROTEZIONE
9	79035757	2	192T	HOSE ASSY	TUBO FLESS.C/RACCORDI
10	79039820	1	190T	LINE - REAR	TUBAZIONE - POSTERIORE
11	79039822	1	70R	GUARD	RIPARO
12	76016704	1	171C	OPERATING CYLINDER - ASSEMBLY SEE SGR. E3.32/4 D2948	CILINDRO OPERATORE - COMPLETO VEDERE SGR. E3.32/4 D2948
	79039545	1	171C	OPERATING CYLINDER - ASSEMBLY SEE SGR. E3.32/4 C1612	CILINDRO OPERATORE - COMPLETO VEDERE SGR. E3.32/4 C1612
	79047906	1	171C	OPERATING CYLINDER - ASSEMBLY SEE SGR. E3.32/4 D1612	CILINDRO OPERATORE - COMPLETO VEDERE SGR. E3.32/4 D1612
		1	171C	OPERATING CYLINDER - ASSEMBLY SEE SGR. E3.32/4 C2948	CILINDRO OPERATORE - COMPLETO VEDERE SGR. E3.32/4 C2948

HYDRAULIC SYSTEM - IMPIANTO IDRAULICO - SYSTEME HYDRAULIQUE - HYDRAULIKANLAGE
SISTEMA HIDRAULICO

E3.02/7

N.T.R. 191 - 20.02.1990

604.01.081.04

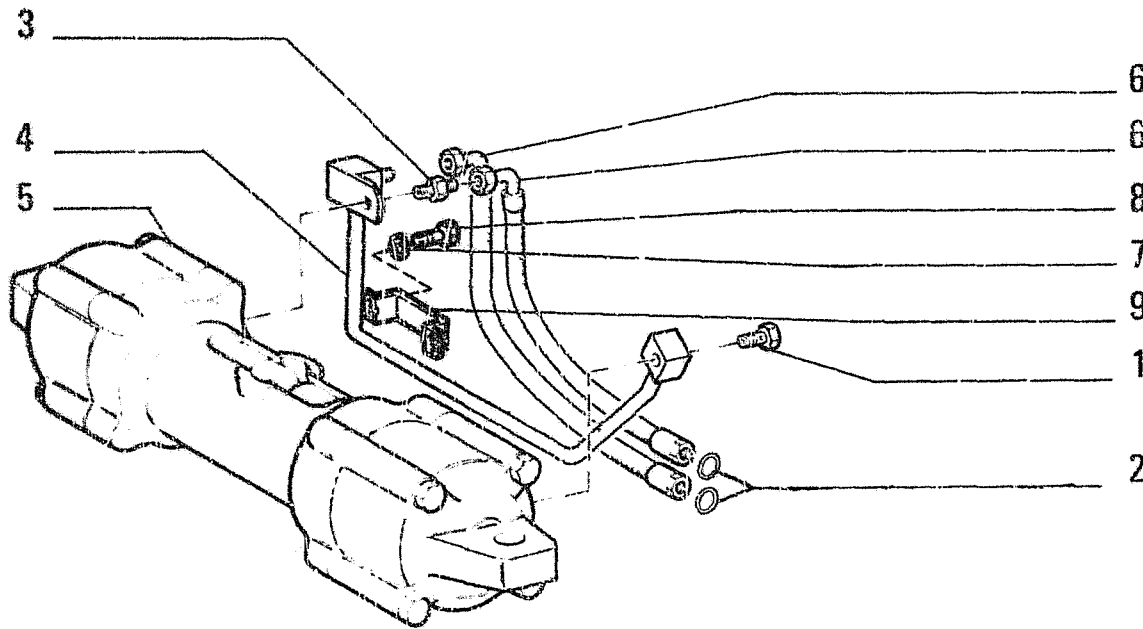

OPTIONAL
VARIANTE 30.1065.01.1

ITEM	PART NUMBER	QTY	TRANS CODE	DESCRIPTION	DESCRIZIONE
1	8299534	1	90B	FILLER PLUG	BOCCHETTONE INTRODUZIONE
2	45481995	4	133R	SEAL	ROSETTA DI TENUTA
3	79028197	1	90B	FILLER PLUG	BOCCHETTONE INTRODUZIONE
4	79028198	1	190T	LINE	TUBAZIONE
5	79029863	1	171C	OPERATING CYLINDER - ASSEMBLY SEE SGR. E3.32/3 C2872	CILINDRO OPERATORE - COMPLETO VEDERE SGR. E3.32/3 C2872
	79099275	1	171C	OPERATING CYLINDER - ASSEMBLY SEE SGR. E3.32/3 D2872	CILINDRO OPERATORE - COMPLETO VEDERE SGR. E3.32/3 D2872
6	79035759	2	192T	HOSE ASSY	TUBO FLESS.C/RACCORDI
7	10571871	2	132R	LOCKWASHER 10,2x2,2	ROSETTA DI SICUREZZA 10,2x2,2
8	11106231	2	40V	SCREW 10x1,5x25	VITE 10x1,5x25
9	79050648	1	225S	BRACKET	STAFFA

HYDRAULIC SYSTEM - IMPIANTO IDRAULICO - SYSTEME HYDRAULIQUE - HYDRAULIKANLAGE
SISTEMA HIDRAULICO

E3.02/6

N.T.R. 191 - 20.02.1990

604.01.081.04

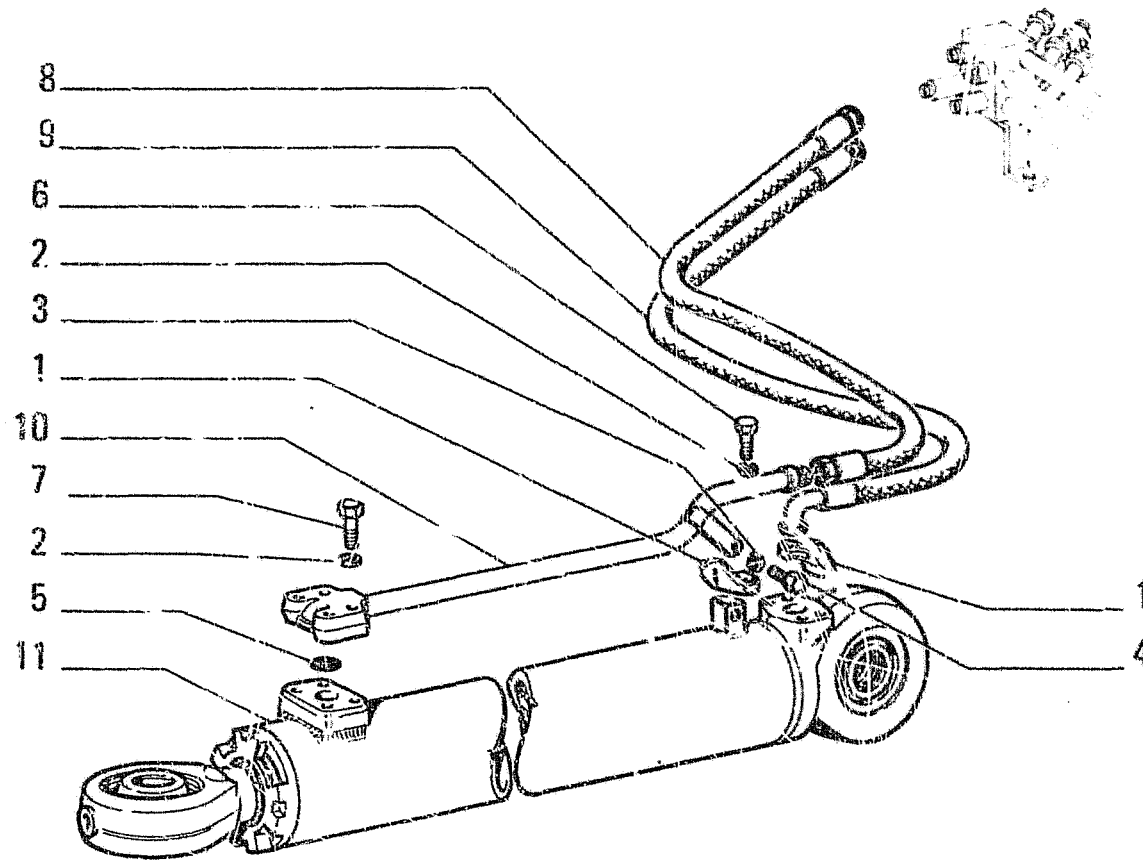

ITEM	PART NUMBER	QTY	TRANS CODF	DESCRIPTION	DESCRIZIONE
1	8297995	4	7/F	FLANGE	FLANGIA
2	10516671	16	1/2R	LOCKWASHER 8,1x2,2	ROSETTA DI SICUREZZA 8,1x2,2
3	10516871	2	3/8R	LOCKWASHER 10x2,5	ROSETTA DI SICUREZZA 10x2,5
4	11106031	2	40V	SCREW 10x1,5x20	VITE 10x1,5x20
5	14457280	2	158G	O-RING 2,62x15,54	GUARNIZIONE O-R 2,62x15,54
6	15043631	8	40V	SCREW 8x1,25x25	VITE 8x1,25x25
7	16044131	3	40V	SCREW 8x1,25x45	VITE 8x1,25x45
8	79035758	2	192T	HOSE ASSY	TUBO FLESS.C/RACCORDI
9	79035764	2	192T	HOSE ASSY	TUBO FLESS.C/RACCORDI
10	79039912	2	190T	LINE	TUBAZIONE
11	79039483	2	171C	OPERATING CYLINDER - ASSEMBLY SEE SGR. E3.32/2 C1612	CILINDRO OPERATORE - COMPLETO VEDERE SGR. E3.32/2 C1612
	79047905	2	171C	OPERATING CYLINDER - ASSEMBLY SEE SGR. E3.32/2 D1612	CILINDRO OPERATORE - COMPLETO VEDERE SGR. E3.32/2 D1612

OPTIONAL
VARIANTE 30.1030.02.1

HYDRAULIC SYSTEM - IMPIANTO IDRAULICO - SYSTEME HYDRAULIQUE - HYDRAULIKANLAGE -
SISTEMA HIDRÁULICO

E3.02/5

2

N.T.R. 191 - 20.02.1990

604.01.081.04

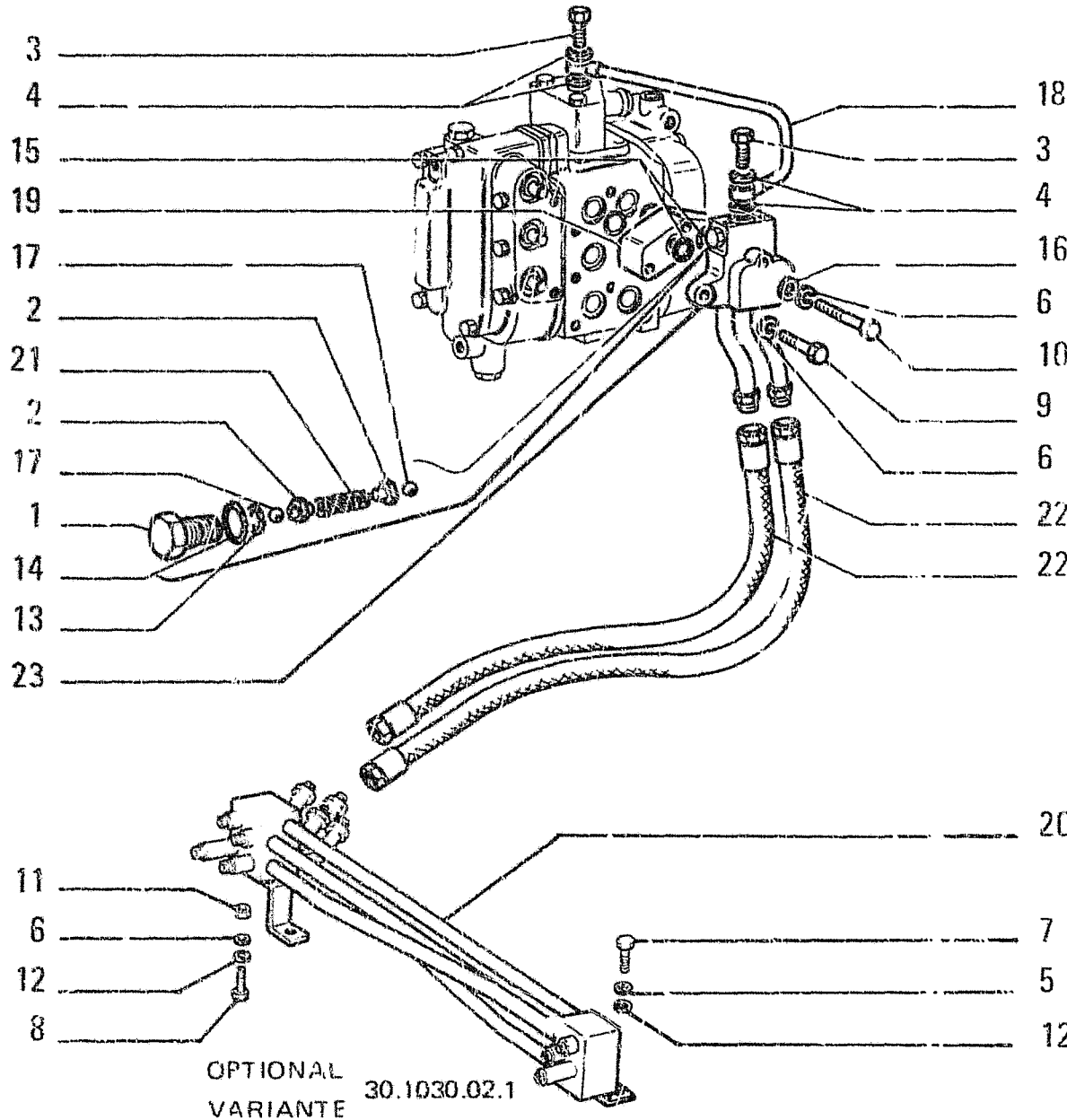

ITEM	PART NUMBER	QTY	TRANS CODE	DESCRIPTION	DESCRIZIONE
1	8201706	1	50T	PLUG	TAPPO
2	5291707	2	147G	SPRING GUIDE	GUIDA DELLA MOLLA
3	10181717	2	20R	FITTING 12x1,5x11	RACCORDO 12x1,5x 11
4	10296160	4	133R	SEAL 12,2x18	ROSETTA DI TENUTA 12,2x18
5	10516821	1	132R	LOCKWASHER 10,2x2,5	ROSETTA DI SICUREZZA 10,2x2,5
5	10516871	4	132R	LOCKWASHER 10x2,5	ROSETTA DI SICUREZZA 10x2,5
7	11106331	1	40V	SCREW 10x1,5x28	VITE 10x1,5x28
8	11106331	1	40V	SCREW 10x1,5x35	VITE 10x1,5x35
9	11108231	1	40V	SCREW 10x1,5x100	VITE 10x1,5x100
10	11108631	2	40V	SCREW 10x1,5x120	VITE 10x1,5x120
11	11701721	1	10D	NUT 10x1,5x8	DADO 10x1,5x8
12	12646821	2	131R	WASHER 10,2x25	ROSETTA 10,2x25
13	14452980	1	150G	O-RING 1,70x9,25	GUARNIZIONE O-R 1,70x9,25
14	14457180	1	158G	O-RING 2,62x13,94	GUARNIZIONE O-R 2,62x13,94
15	14462980	2	150G	O-RING 3,53x20,22	GUARNIZIONE O-R 3,53x20,22
16	14496621	2	131R	WASHER 10,5x21	ROSETTA 10,5x21
17	20063450	2	140S	BALL 6,350	SFERA 6,350
18	79021558	1	193T	TUBE	TUBO RIGIDO
19	79021643	1	75D	SPACER	DISTANZIALE
20	79021644	1	190T	LINE	TUBAZIONE
21	79022809	1	100M	SPRING	MOLLA
22	79035754	2	192T	HOSE ASSY	TUBO FLESS.C/RACCORDI
23	79041764	1	70F	FLANGE	FLANGIA

HYDRAULIC SYSTEM - IMPIANTO IDRAULICO - SYSTEME HYDRAULIQUE - HYDRAULIKANLAGE
 SISTEMA HIDRÁULICO

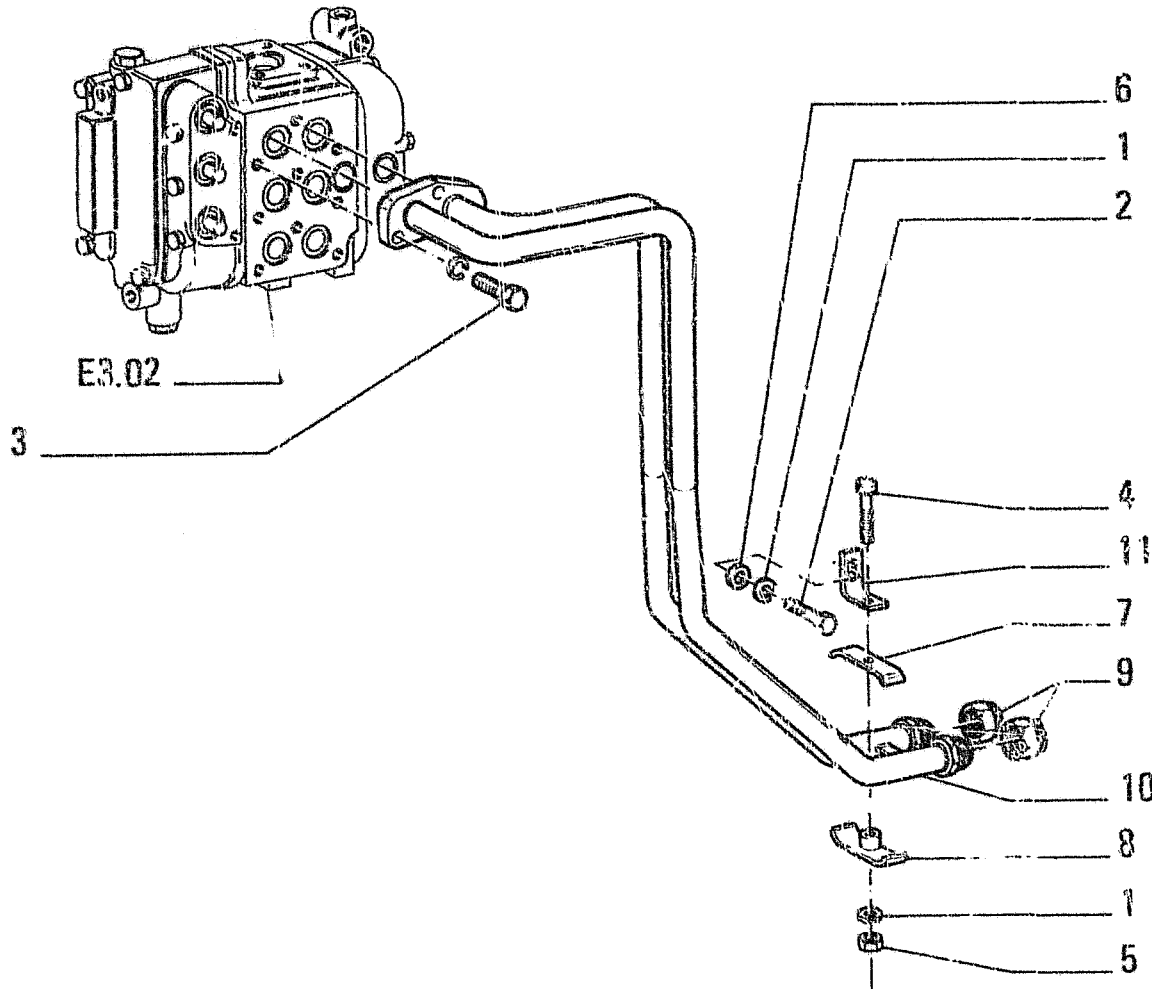

ITEM	PART NUMBER	QTY	TRANS CODE	DESCRIPTION	DESCRIZIONE
1	10516871	2	131W	WASHER 10x2,5	ROSETTA 10x2,5
2	11106231	1	40V	SCREW 10x1,5x25	VITE 10x1,5x25
3	11107031	3	40V	SCREW 10x1,5x45	VITE 10x1,5x45
4	11107531	1	40V	SCREW 10x1,5x65	VITE 10x1,5x65
5	11701721	1	10D	NUT 10x1,5x8	CAPO 10x1,5x8
6	13550421	1	132R	LOCKWASHER 10,2x20	ROSETTA DI SICUREZZA 10,2x20
7	79023908	1	225S	BRACKET	STAFFA
8	79028455	2	225S	BRACKET	STAFFA
9	79028462	2	50T	PLUG	TAPPO
10	79029841	1	190T	LINE	TUBAZIONE
11	79029844	1	225S	BRACKET	STAFFA

OPTIONAL
VARIANTE 30.1281.01.1

HYDRAULIC SYSTEM – IMPIANTO IDRAULICO – SYSTEME HYDRAULIQUE – HYDRAULIKANLAGE –
SISTEMA HIDRÁULICO

E3.02/4

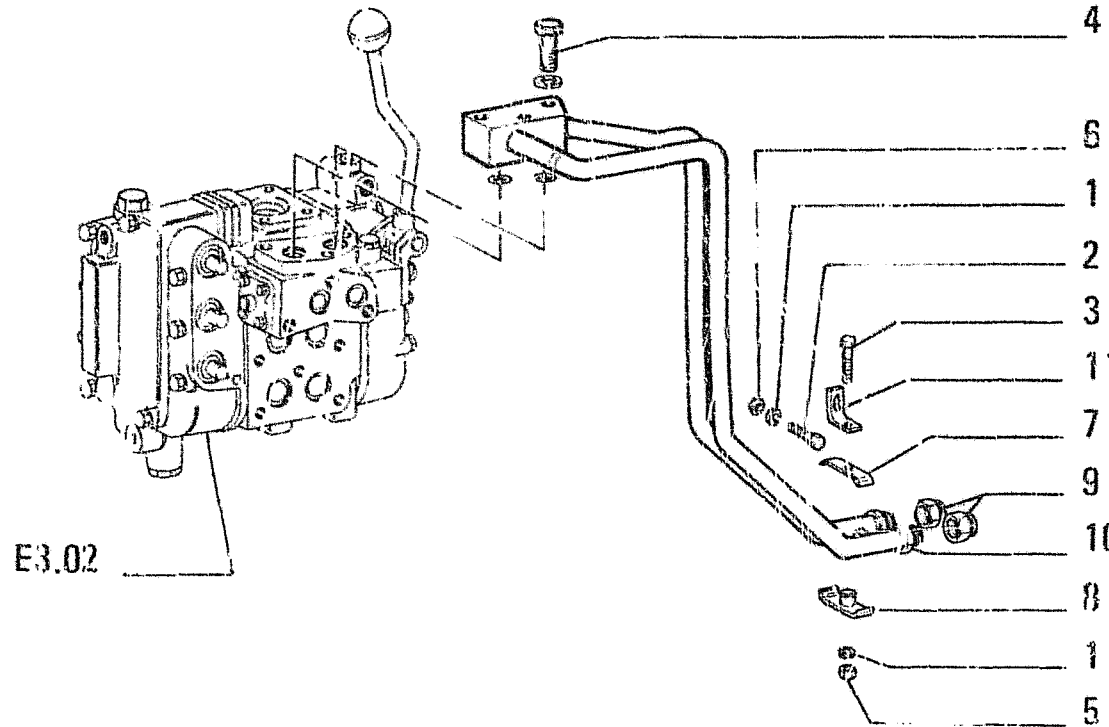

E3.02

OPTIONAL
VARIANTE 30.128U.05.1

ITEM	PART NUMBER	QTY	TRANS CODE	DESCRIPTION	DESCRIZIONE
1	10516871	2	132R	LOCKWASHER 10x2,5	ROSETTA DI SICUREZZA 10x2,5
2	11106231	1	40V	SCREW 10x1,5x25	VITE 10x1,5x25
3	11107331	1	40V	SCREW 10x1,5x55	VITE 10x1,5x55
4	11107431	3	40V	SCREW 10x1,5x60	VITE 10x1,5x60
5	11701721	1	10D	NUT 10x1,5x8	DADO 10x1,5x8
6	13550421	1	131R	WASHER 10,2x20	ROSETTA 10,2x20
7	79023998	2	225S	BRACKET	STAFFA
8	79028455	1	225S	BRACKET	STAFFA
9	79028462	2	50T	PLUG	TAPPO
10	79029790	1	190T	LINE	TUBAZIONE
11	79029844	1	225S	BRACKET	STAFFA

HYDRAULIC SYSTEM - IMPIANTO IDRAULICO - SYSTEME HYDRAULIQUE - HYDRAULIKANLAGE -
SISTEMA HIDRÁULICO

E3.02/3

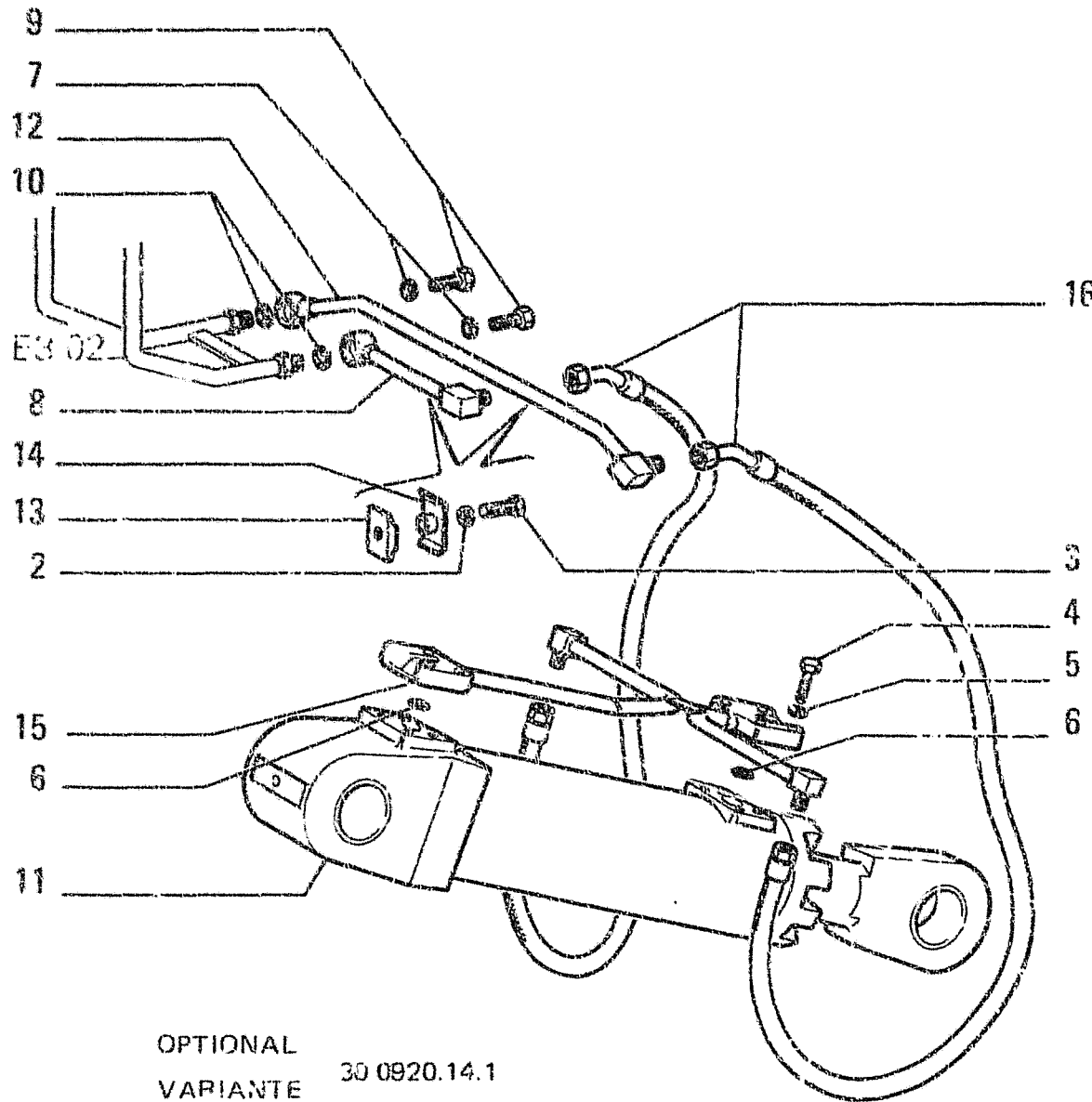

OPTIONAL
VARIANTE 30 0920.14.1

HYDRAULIC SYSTEM - IMPIANTO IDRAULICO - SYSTEME HYDRAULIQUE - HYDRAULIKANLAGE -
SISTEMA HIDRÁULICO

ITEM	PART NUMBER	QTY	TRANS CODE	DESCRIPTION	DESCRIZIONE
2	10516971	9	132R	LOCK/WASHER 10x2,5	ROSETTA DI SICUREZZA 10x2,5
3	11106031	1	40V	SCREW 10x1,5x35	VITE 10x1,5x35
4	11107031	8	40V	SCREW 10x1,5x45	VITE 10x1,5x45
5	10571871	2	133R	SEAL 10,2x2,2	ROSETTA DI TENUTA 10,2x2,2
6	14463080	2	158G	O-RING 3,53x21,82	GUARNIZIONE O-R 3,53x21,82
7	45481995	2	133R	SEAL	ROSETTA DI TENUTA
8	79023510	1	190T	LINE - REAR	TUBAZIONE - POSTERIORE
9	79023515	2	20R	FITTING	RACCORDO
10	79023516	2	133R	SEAL	ROSETTA DI TENUTA
11	79023523	1	171C	OPERATING CYLINDER - ASSEMBLY SEE SGR. E3.32/1	CILINDRO OPERATORE - COMPLETO VEDERE SGR. E3.32/1
12	79030703	1	190T	LINE - REAR	TUBAZIONE - POSTERIORE
13	79030705	1	110P	PLAQUE	PIASTRINA
14	79030706	1	110P	PLAQUE	PIASTRINA
15	79031114	1	190T	LINE	TUBAZIONE
16	79034377	2	192T	HOSE ASSY	TUBO FLESS.C/RACCORDI

E3.02/2

N.T.R. 205 - 30.09.1991
604.01.081.06

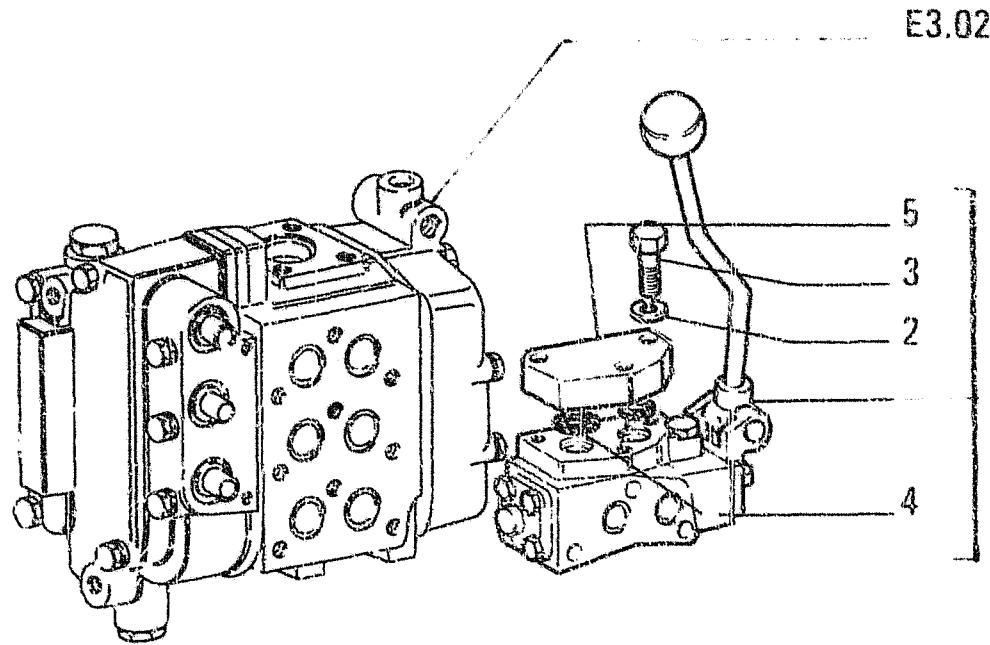

E3.02

ITEM	PART NUMBER	QTY	TRANS CODE	DESCRIPTION	DESCRIZIONE
1	8296665	1	27D	DIVERTER VALVE - ASSEMBLY SEE SGR. E3.31/1	DEVIATORE - COMPLETO VEDERE SGR. E3.31/1
2	10516871	3	132R	LOCKWASHER 10x2,5	ROSETTA DI SICUREZZA 10x2,5
3	11106831	3	40V	SCREW 10x1,5x40	VITE 10x1,5x40
4	14462880	2	158G	O-RING 3,53x13,64	GIARNIZIONE O-R 3,53x13,64
5	79027335	1	70F	FLANGE	FLANGIA

OPTIONAL
VARIANTE 30.0090.10.1

HYDRAULIC SYSTEM - IMPIANTO IDRAULICO -- SYSTEME HYDRAULIQUE -- HYDRAULIKANLAGE --
SISTEMA HIDRAULICO

E3.02/1

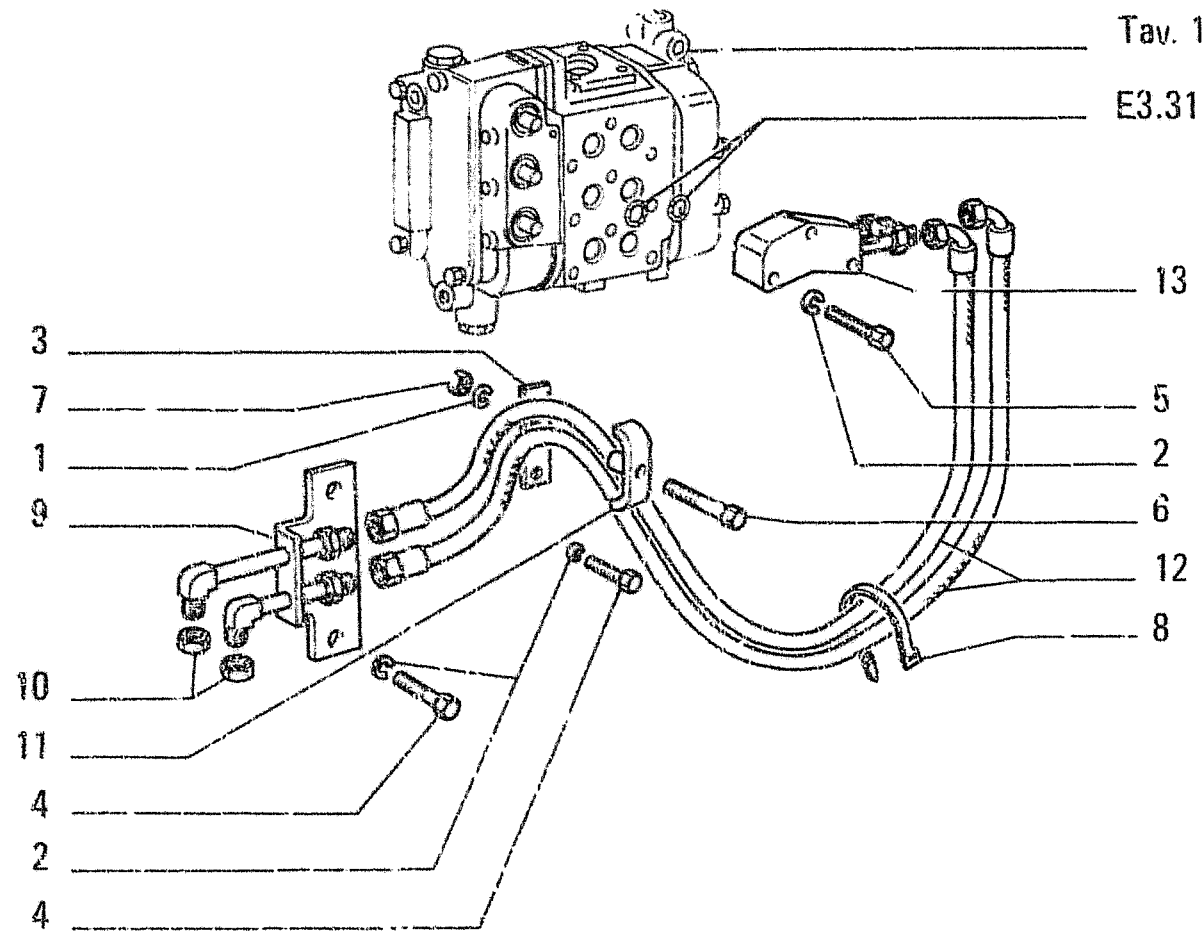

ITEM	PART NUMBER	QTY	TRANS CODE	DESCRIPTION	DESCRIZIONE
1	10519601	1	170R	LOCKWASHER 8,15x17	ROSETTA EL. 8,15x17
2	10516871	6	170R	LOCKWASHER 10x2,5	ROSETTA EL. 10x2,5
3	79021616	1	225S	BRACKET	STAFFA
4	11106231	2	40V	SCREW 10x1,5x25	VITE 10x1,5x25
5	11107231	3	40V	SCREW 10x1,5x50	VITE 10x1,5x50
6	16044031	1	40V	SCREW 8x1,25x40	VITE 8x1,25x40
7	16100821	1	10D	NUT 8x1,25x6,5	DADO 8x1,25x6,5
8	79001971	1	31F	CLAMP	FASCETTA
9	76010197	1	193T	TUBE	TUBO RIGIDO
10	79045845	2	50T	PLUG	TAPPO
11	79022017	1	225S	BRACKET	STAFFA
12	76010202	2	285T	HOSE	TUBO FLESSIBILE
13	76008671	1	193T	TUBE	TUBO RIGIDO

D1616 tel. n. 250852 →

HYDRAULIC SYSTEM - IMPIANTO IDRAULICO - SYSTEME HIDRAULIQUE - HYDRAULIKANLAGE -
SISTEMA HIDRAULICO

E3.02

6A

N.T.R. 158 - 13.03.1987
604.01.081.03

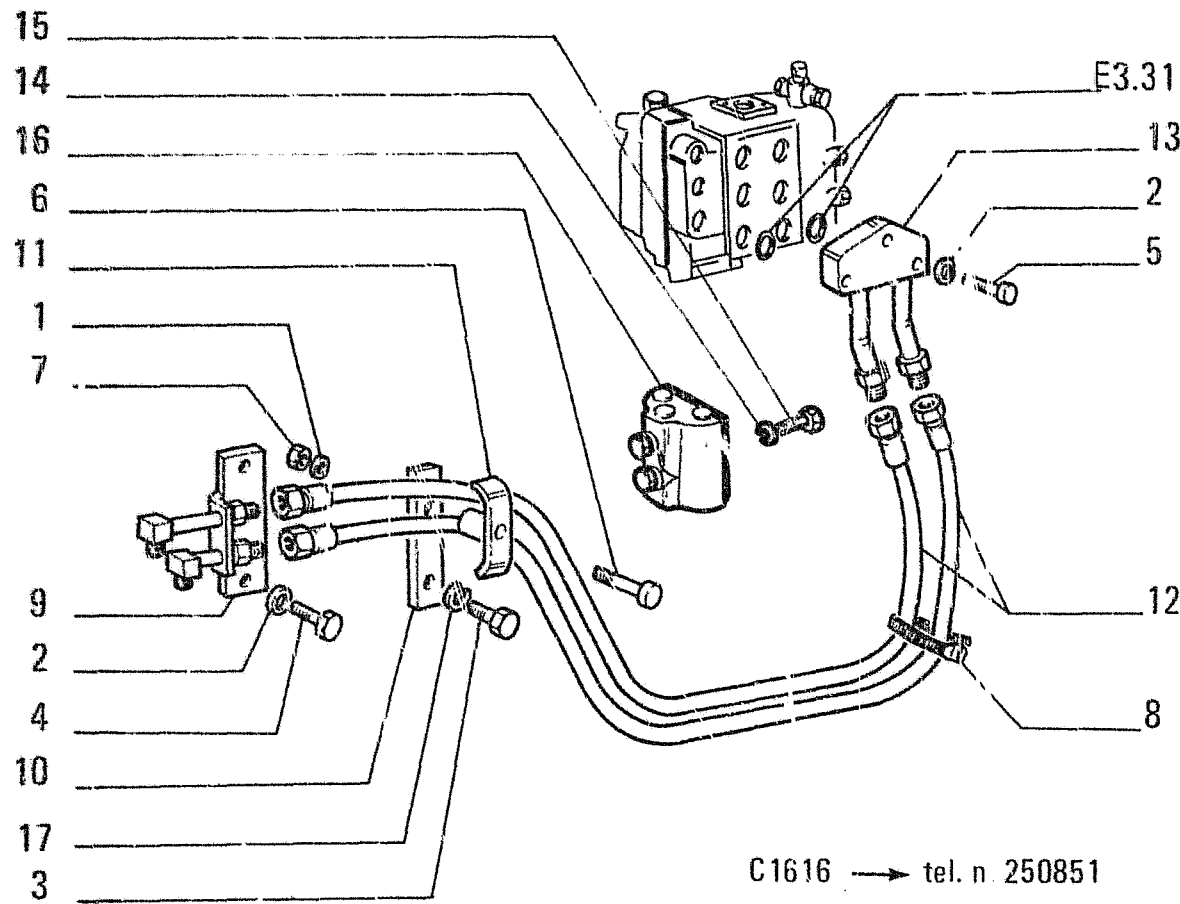

ITEM	PART NUMBER	QTY	TRANS CODE	DESCRIPTION	DESCRIZIONE
1	10516671	1	170R	LOCKWASHER 8,1x2,2 C1510	ROSETTA EL. 8,1x2,2 C1510
	10519601	1	170R	LOCKWASHER 8,15x17 D1510	ROSETTA EL. 8,15x17 D1510
2	10516871	5	170R	LOCKWASHER 10x2,5	ROSETTA EL. 10x2,5
3	11106031	1	40V	SCREW 10x1,5x20 C1510	VITE 10x1,5x20 C1510
4	11106231	2	40V	SCREW 10x1,5x25	VITE 10x1,5x25
5	11107031	3	40V	SCREW 10x1,5x45	VITE 10x1,5x45
6	16044031	1	40V	SCREW 8x1,25x40 D1510	VITE 8x1,25x40 D1510
	16044131	1	40V	SCREW 8x1,25x45 C1510	VITE 8x1,25x45 C1510
7	16100821	1	10D	NUT 8x1,25x6,5	DADO 8x1,25x6,5
8	79001971	1	31F	CLAMP	FASCETTA
9	79018215	1	193T	TUBE	TUBO RIGIDO
10	79021616	1	225S	BRACKET C1510	STAFFA C1510
11	79022017	1	225S	BRACKET	STAFFA
12	79036640	2	215T	HOSE	TUBO FLESSIBILE
13	79018210	1	190T	LINE C1159	TUBAZIONE C1159
	79043703	1	190T	LINE D1159	TUBAZIONE D1159
14	10516671	4	170R	LOCKWASHER 8,1x2,2 C1159	ROSETTA EL. 8,1x2,2 C1159
15	16043831	4	40V	SCREW 8x1,25x30 C1159	VITE 8x1,25x30 C1159
16	79035103	1	10V	VALVE - ASSEMBLY SEE SGR. E3.34 C1159	VALVOLA - COMPLETO VEDERE SGR. E3.34 C1159
17	10516871	1	170R	LOCKWASHER 10x2,5 C1510	ROSETTA EL. 10x2,5 C1510

HYDRAULIC SYSTEM - IMPIANTO IDRAULICO - SYSTEME HYDRAULIQUE - HYDRAULIKANLAGE
 SISTEMA HIDRAULICO

E3.02 6

N.T.R. 158 - 13.03.1987
 604.01.081.03

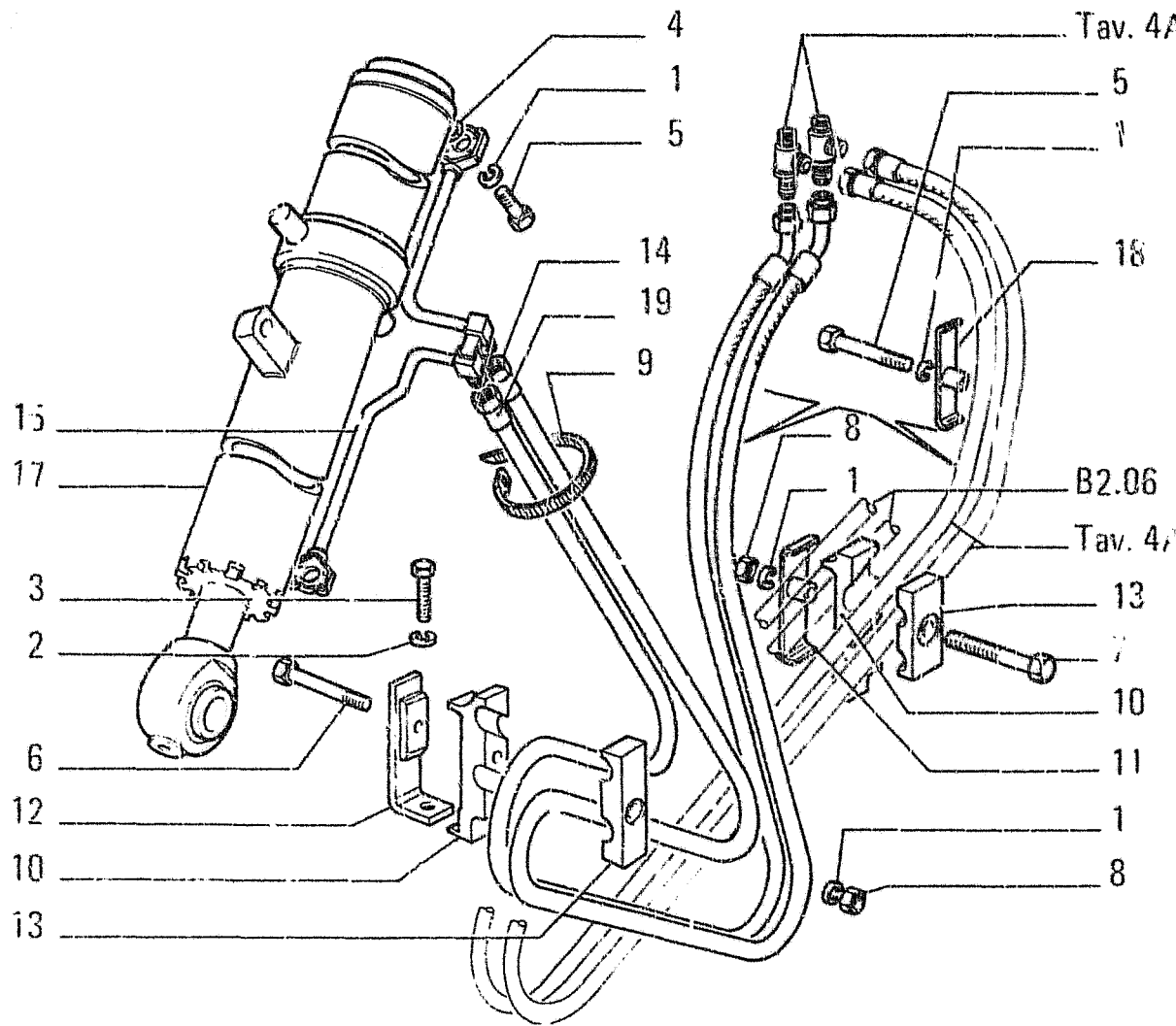

ITEM	PART NUMBER	QTY	TRANS CODE	DESCRIPTION	DESCRIZIONE
1	10516671	20	132R	LOCKWASHER 8,1x2,2	ROSETTA DI SICUREZZA 8,1x2,2
2	10516871	1	132R	LOCKWASHER 10x2,5	ROSETTA DI SICUREZZA 10x2,5
3	11106231	1	40V	SCREW 10x1,5x25	VITE 10x1,5x25
4	14457280	4	158G	O-RING 2,62x15,54	GUARNIZIONE O-R 2,62x15,54
5	16044131	18	40V	SCREW 8x1,25x45	VITE 8x1,25x45
6	16044531	1	40V	SCREW 8x1,25x65	VITE 8x1,25x65
7	16044631	1	40V	SCREW 8x1,25x70	VITE 8x1,25x70
8	16100821	2	10D	NUT 8x1,25x6,5	DAIDO 8x1,25x6,5
9	79001971	1	31F	CLAMP - RIGHT	FASCETTA - DESTRO
10	79021898	2	225S	BRACKET	STAFFA
11	79021899	1	225S	BRACKET - LEFT	STAFFA - SINISTRO
12	79021902	1	225S	BRACKET	STAFFA
13	79030421	2	225S	BRACKET	STAFFA
14	76010182	1	285T	HOSE - RIGHT	TUBO FLESSIBILE - DESTRO
15	76010175	1	130T	LINE - RIGHT	TUBAZIONE - DESTRO
	76010176	1	190T	LINE - LEFT	TUBAZIONE - SINISTRO
17	76016701	2	171C	OPERATING CYLINDER - ASSEMBLY SEE SGR. E3.32 C1948	CILINDRO OPERATORE - COMPLETO VEDERE SGR. E3.32 C1948
	79047903	2	171C	OPERATING CYLINDER - ASSEMBLY SEE SGR. E3.32 C1948	CILINDRO OPERATORE - COMPLETO VEDERE SGR. E3.32 C1948
18	79028166	2	225S	BRACKET	STAFFA
19	76010183	1	285T	HOSE - RIGHT	TUBO FLESSIBILE - DESTRO

D1616 tel. n. 250852 →

HYDRAULIC SYSTEM - IMPIANTO IDRAULICO - SYSTEME HYDRAULIQUE - HYDRAULIKANALAGE -
SISTEMA HIDRAULICO

E3.02

5A

N.T.R. 191 - 20.02.1990

604.01.081.04

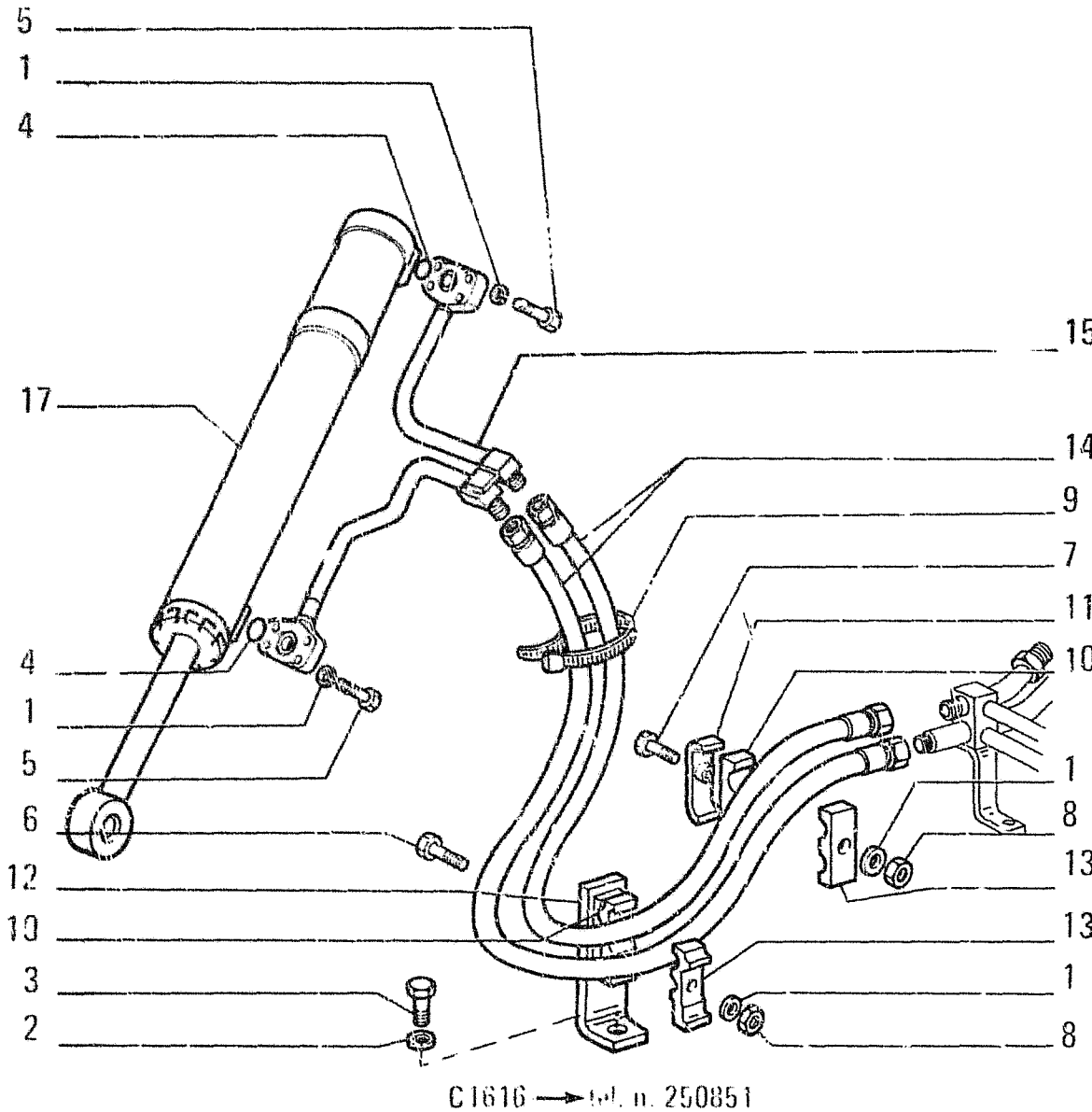

ITEM	PART NUMBER	QTY	TRANS CODE	DESCRIPTION	DESCRIZIONE
1	10516671	18	132R	LOCKWASHER 8,1x2,2	ROSETTA DI SICUREZZA 8,1x2,2
2	10516871	1	132R	LOCKWASHER 10x2,5	ROSETTA DI SICUREZZA 10x2,5
3	11106231	1	40V	SCREW 10x1,5x25	VITE 10x1,5x25
4	144E7280	4	158G	O-RING 2,62x15,54	GUARNIZIONE O-R 2,62x15,54
5	16044131	16	40V	SCREW 8x1,25x45	VITE 8x 25x45
6	16044531	1	40V	SCREW 8x1,25x65	VITE 8x1,25x65
7	16044631	1	40V	SCREW 8x1,25x70	VITE 8x1,25x70
8	16100821	2	10D	NUT 8x1,25x6,5	DADO 8x1,25x6,5
9	79001971	1	31F	CLAMP - RIGHT	FASCETTA - DESTRO
10	79021898	2	225S	BRACKET	STAFFA
11	79021899	1	225S	BRACKET - LEFT	STAFFA - SINISTRO
12	79021902	1	225S	BRACKET	STAFFA
13	79030421	2	225S	BRACKET	STAFFA
14	79036641	4	192T	HOSE ASSY	TUBO FLESS.C/RACCORDI
15	79039806	1	190T	LINE - RIGHT	TUBAZIONE - DESTRO
	79039807	1	190T	LINE - LEFT	TUBAZIONE - SINISTRO
17	76016701	2	171C	OPERATING CYLINDER - ASSEMBLY SEE SGR. E3.32 D2948	CILINDRO OPERATORE - COMPLETO VEDERE SGR. E3.32 D2948
	79039427	2	171C	OPERATING CYLINDER - ASSEMBLY SEE SGR. E3.32 C1612	CILINDRO OPERATORE - COMPLETO VEDERE SGR. E3.32 C1612
	79047903	2	171C	OPERATING CYLINDER - ASSEMBLY SEE SGR. E3.32 D1612	CILINDRO OPERATORE - COMPLETO VEDERE SGR. E3.32 D1612
		2	171C	OPERATING CYLINDER - ASSEMBLY SEE SGR. E3.32 C2948	CILINDRO OPERATORE - COMPLETO VEDERE SGR. E3.32 C2948

HYDRAULIC SYSTEM - IMPIANTO IDRAULICO - SYSTEME HYDRAULIQUE - HYDRAULIKANLAGE
 SISTEMA HIDRAULICO

E3.02

5

N.T.R. 191 - 20.02.1990

604.01.081.04

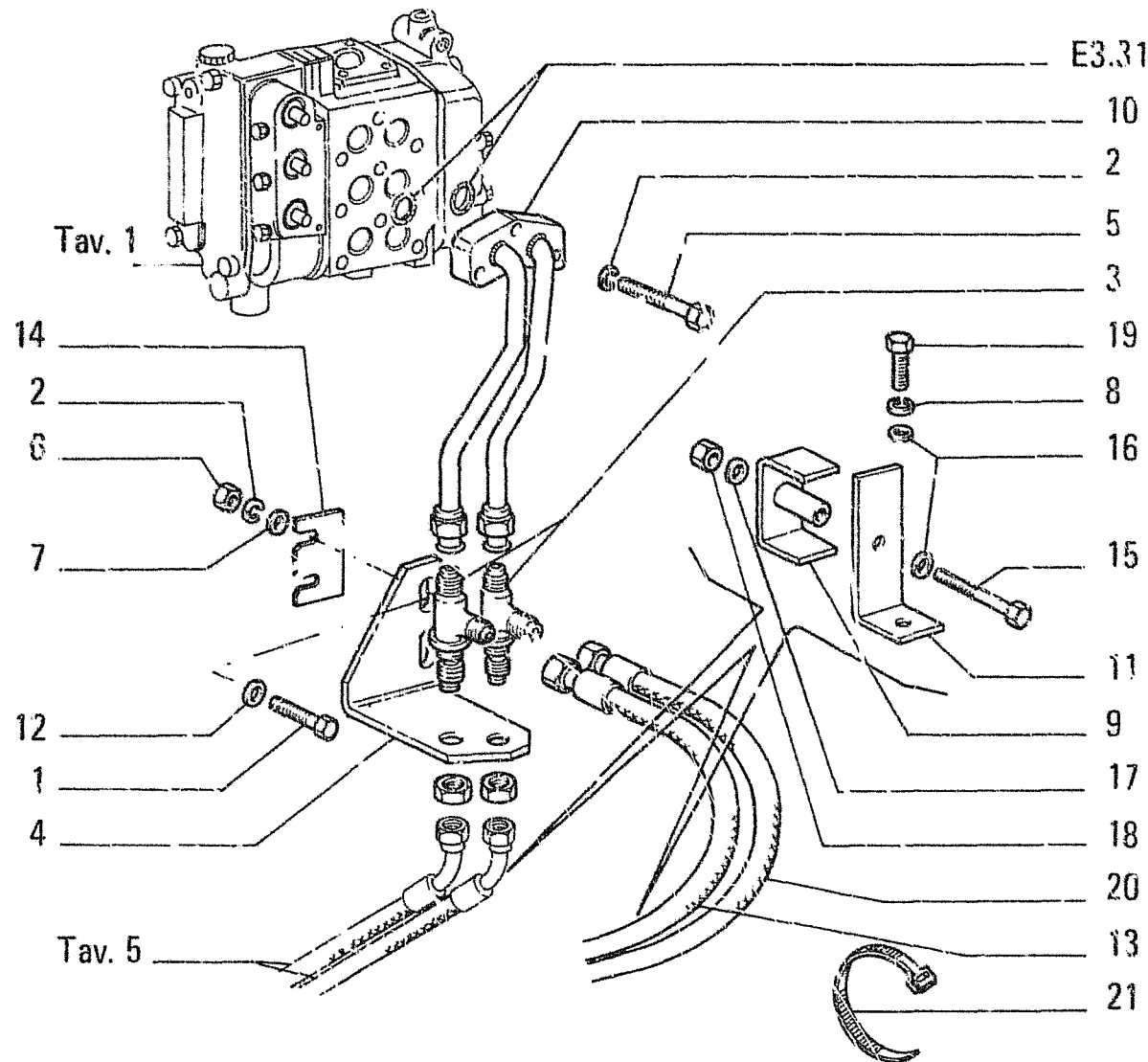

D1616 tal. n. 250852 →

QTY	PART NUMBER	TRANS CODE	DESCRIPTION	DESCRIZIONE
2	11106831	40V	SCREW 10x1,5x40	VITE 10x1,5x40
5	10518371	132R	LOCKWASHER 10x2,5	ROSETTA DI SICUREZZA 10x2,5
2	76008843	20F	FITTING	RACCORDO
1	76010187	225S	BRACKET	STAFFA
3	11107031	40V	SCREW 10x1,5x45	VITE 10x1,5x45
2	11701721	10D	NUT 10x1,5x8	DADO 10x1,5x8
2	12646821	131R	WASHER 10,2x25	ROSETTA 10,2x25
2	10569470	170R	LOCKWASHER 10,2x2,5	ROSETTA EL. 10,2x2,5
2	76010189	231S	CLIP	STAFFETTA
1	76010177	190T	LINE REAR	TUBAZIONE - POSTERIORE
2	76010188	231S	CLIP	STAFFETTA
2	12644321	131R	WASHER 10,2x35	ROSETTA 10,2x35
1	76010184	285T	HOSE - LEFT	TUBO FLESSIBILE - SINISTRO
	76010186	190S	SHIM	SPESSORE
2	15971421	40V	SCREW 10x1,25x80	VITE 10x1,25x80
4	14496601	131R	WASHER 10,5x21	ROSETTA 10,5x21
2	10516870	170R	LOCKWASHER 10,2x2,5	ROSETTA EL. 10,2x2,5
2	12164711	10C	NUT 10x1,25x8	DADO 10x1,25x8
2	11106321	40V	SCREW 10x1,5x28	VITE 10x1,5x28
1	76010185	285T	HOSE - LEFT	TUBO FLESSIBILE - SINISTRO
1	79001971	31F	CLAMP	FASCETTA

HYDRAULIC SYSTEM - IMPIANTO IDRAULICO - SYSTEME HYDRAULIQUE - HYDRAULIKANLAGE -
SISTEMA HIDRAULICO

E3.02

4A

N.T.R. 158 - 13.03.1987
604.01.081.03

DE DENOMINAZIONE BASE	BASIC DESIGNATION	DENIGNATIONS BASES	GRUNDBEZEICHNUNGEN	DENOMINACIONES BASE
319C	CRISTALLO ATERMICO	ATHERMIC GLASS PANE	GLACE ATHERMIQUE	CRISTAL ATERMICO
32GA	TRASMISSIONE POSTERIORE	REAR TRANSMISSION	TRANSMISSION ARRIERE	
320C	GROCIERA	SPIDER	CROISILLON	CRUCETA
3201	PNEUMATICI 14.00X24	TIRES 14.00X24	PNEUS 14.00X24	
3208	PNEUMATICI 15.5X25	TIRES 15.5X25	PNEUS 15.5X25	
3209	PNEUMATICI 17.5X25	TIRES 17.5X25	PNEUS 17.5X25	
321C	CRONOGIROMETRO	TACHOMETER	TACHYMETRE	QUENTAREVOLUCIONES
3210	PNEUMATICI 22X25	TIRES 22X25	PNEUS 22X25	
3211	PNEUMATICI 20.5X25	TIRES 20.5X25	PNEUS 20.5X25	
3213	PNEUMATICI 26.5X25	TIRES 26.5X25	PNEUS 26.5X25	
3219	PNEUMATICI 29.5X25	TIRES 29.5X25	PNEUS 29.5X25	
322C	CRONOTACHIMETRO	SPEEDOMETER	CHRONOTACHYMETRE	CRONOTACOMETRIC
325C	CRUSCOTTO	DASHBOARD	PLANCHE DE BORD	TABLERO
330C	CUFFIA RADIATORE	RADIATOR GUARD	CAPOT	CAPUCHON
331C	CUFFIA DI GOMMA	RUBBER BOOT	CAPUCHON CAOUT- CHOUIC	CAPUCHON DE CAUCHO
331C			CALOTTE DE PRO- JECTEUR	SOPORTE DEL PROYECTOR
332C	CUFFIA PER PROIETTORE	HEADLAMP BOOT	KEIL	GUARDAPOLVO
332C			STAUSSCHUTZKAFFE	
333C	CUNEO	WEDGE	RAEDER MIT FELGE 14.00-25	
334C	CUFFIA PARAPOLVERE	DUST BOOT	RAEDER MIT FELGE 8.00TG-24	
3402	RUOTE CON CERCHIO 14.00-25	WHEELS W/RIM 14.00-25	ROULEMENT	RODAMIENTO
3403	RUOTE CON CERCHIO 8.00TG-24	WHEELS W/RIM 8.00TG-24	COUSSIN	ALMOHADA
341C	CUSCINETTO	BEARING	POCHETTE A PAPIERS	FUNDA PARA MAPAS
345C	CUSCINO	CUSHION	BLOCAGE HYDRAULIQUE	ANCLAJE HYDRAULICO
348C	CRISTODIA PER LIBRETTI	PORTFOLIO	FREINS DE STATIONNEMENT	
35G5	BLOCCAGGIO IDRAULICO	HYDRAULIC LOCK		
37G3	COMANDO FRENI SERVIZIO	BRAKE PEDALS		
37G4	COMANDO FRENI STAZIONAMENTO	PARKING BRAKE		
39G2	COMANDO FRIZIONI DI STERZO	STEERING CONTROL		
39G6	TUBAZIONI EST FRIZIONI STERZO	STEERING OUTER PIPING		
39G7	TUBAZIONI COLLEG. FRIZ. STERZO	STEERING CONNECTING PIPING		
390C	CORNICE DELLA TARGA	NUMBER PLATE FRAME	MONTURE DE PLAQUE	MARCO DE MATRICULA
390C				
391C	CORNICE DEL PROIETTORE	HEADLAMP RIM	MONTURE DE PRO- JECTEUR	MARCO DE PROYECTOR
391C				
392C	CORNICE DI GOMMA	WEATHERSEAL STRIP	CONTOUR CAOUTCHOUIC	BURLETE DE GOMA
393C	CABINA SICUREZZA	ROPS CAB	CABINE DE SECURITE	CABINA DE SEGURIDAD
394C	CASSETTO DISTRIBUTORE	CONTROL VALVE SPOOL	BOITE DISTRIBUTEUR	CORREDERA DEL DISTRIBUTOR
395C	COLORIE	COLOR	COULEUR	COLOR
396C	CORPO TRATTORE	TRACTOR BODY	CORPS TRACTEUR	CUERPO TRACTOR

DESIGNAZIONE BASE	BASIC DESIGNATION	DESIGNATIONS-BASES	GRUNT/BEZEICHNUNGEN	DENOMINACIONES BASE
397C	CORPO CARRELLO	TRACK FRAME	CORPS DE CHARIOT DE CHENILLE	CARRO DE ORUGA
398C	CRISTALLO COLORATO	TINTED THERMIC GLASS PANE	GLACE THERMIQUE COLORE	CRISTAL COLOREADO
399C	CONVERTITTORE PNEUMOIDRAULICO	POWER CLUSTER	SERVO-FREIN HYDROPNEUMATIQUE	SERVOFRENO NEUMOHIDRAULICO
400C	COMBUSTIBILE	FUEL	COMBUSTIBLE	COMBUSTIBLE
401C	COSTAMPATO	MOLD-ON CONNECTOR		
401S	SAPAFINESCA	GATE VALVE	VANNE	COMPUERTA
402S	SCATOLA CAMBIO	TRANSMISSION HOUSING	BOITZ DE VITESSES	CAJA DE CAMBIO
403S	SCATOLA RIDUTTORE FINALE	FINAL DRIVE HOUSING	CARTER DE REDUCTEUR FINAL	CAJA DE REDUCTOR
404S	SCATOLA TRASMISSIONE	REAR HOUSING	CARTER PONT ARRIERE	CAJA DE TRANSMISION
405S	SIGILLANTE	SEALANT	PRODUIT D'ETANCHEITE	SELLADOR
406S	SPRUZZATORE	NOZZLE	GICLEUR	INYECTOR
407S	STRISCIA ANTISDRUCCIOLO	ANTI-SKID	BANDE ANTIDERAPANTE	TIRA CONTRA-DESIZAMIENTO
408S	STRUTTURA PROTEZIONE	ROPS CANOPY	STRUCTURE DE PROTECTION	ESTRUCTURA DE PROTECCION
409S	SEGMENTO FRENO	BRAKE LINING	SEGMENT DE FREIN	ZAPATA DE FRENO
410S	SERBATOIO OLIO IMP. IDRAULICO	HYDRAULIC TANK	RESERVOIR HYDRAULIQUE	DEPOSITO ACEITE SISTEMA HIDR.
411S	SERBATOIO COMBUSTIBILE E OLIO	FUEL AND OIL TANK	RESERVOIR COMBUSTIBLE/HUILE	TANQUE COMBUSTIBLE Y ACEITE
412S	SEMIMAGLIA CINGOLO	HALF TRACK LINK	DEMI-MAILLON	SEMIMALLA DE ORUGA
413S	SEMICERNIERA	HALF HINGE	DEMI-CHARNIERE	SEMIDISAGRA
414S	SCHEMA	SCHEMATIC	SCHEME	ESQUEMA
415S	SEMIFASCIA	HALF BAND	DEMI-BANDE	SEMIFAJA
416S	SBRINATORE	DEFROSTER	DEGIVREUR	DESCONGELADOR
417S	SEMIFLANGIA	HALF FLANGE	DEMI-BRIDE	SEMIBRIDA
418S	SERIE	SET	JEU	JUEGO
419S	ORGANICO SOLLEVAMENTO	LIFT RELEASE VALVE		
420S	SERBATOIO ARIA	AIR RESERVOIR	RESERVOIR A AIR	DEPOSITO DE AIRE
421S	SOLVENTE	SOLVENT	SOLVANT	
469P	PER VARIANTE	FOR SPECIAL EQUIPMENT	POUR VARIANTE	PARA VARIANTE
480A	RIDUTTORE LATERALE	FINAL DRIVE	REDUCTEUR LATERAL	
480P	PERNO A SFERA	BALL PIN	AXE SPHERIQUE	ROTULA
481P	POZZETTO	WELL	ETUI	DEPOSITO
482P	PUNTA DENTE BENNA	BUCKET TOOTH POINT	POINTE DENT DE GODET	TUA DE DIENTE CUCARA
483P	PIATTAFORMA	PLATFORM	PLATE-FORME	PLATAFORMA
50G1	RUOTE CARRELLO CINGOLO	TRACK ROLLERS	ROUE PORTEUR DE CHENILLE	RUEDA DE APOYO DE LA ORUGA
50G2	TENDICINGOLO	TRACK IDLER	TENDEUR DE CHENILLE	
50G3	RULLO SOSTEGNO CINGOLO	TRACK CARRIER ROLLER	GALET DE RETOUR DE CHENILLE	RUEDA DE SOPORTE DE LA ORUGA
50G4	RIPARI CINGOLO	TRACK COVERS	PROTECTIONS DE CHENILLE	BLINDAJE DE CADENAS
56G1	SOSPENSIONE ANT CINGOLO	TRACK FRONT SUSPENSION	SUSPENSION AV. CHENILLE	
56G3	COLLEGAMENTO CARRELLI	TRACK GUIDING PLATES		
56G5	SOSPENSIONE POST CINGOLO	REAR SUSPENSION	SUSPENSION AR. CHENILLE	
600J	VARIANTE A RICHIESTA	SPECIAL EQUIPMENT	EQUIPEMENT SPECIAL	EQUIPO SPECIALE
			LAUFWERKSAUFHANGUNG VORNE	
			LAUFWERKSAUFHANGUNG HINTEN	
			VARIANTEN	
			LAUFWERKSAUFHANGUNG HINTEN	
			VARIANTEN	

DESIGNAZIONE BASE	BASIC DESIGNATION	DESIGNATIONS-BASES	GRUNDBEZEICHNUNGEN	DENOMINACIONES BASE
600U	PROVEDERE IN LOCO	OBTAIN LOCALLY	A PROCURER SEP	CONSEGUIR LOCALMENTE
603W	TAGLIARE DI MISURA	CUT AT ASSEMBLY	COUPER SELON BESOIN	CORTAR SEGUN NECESSARIO
600X	FINO AL TELAIO...	UP TO SERIAL NO...	JUSQU'AU CHASSIS	HASTA EL ARMAZON...
600Y	DAL TELAIO...	FROM THE SERIAL NO...	A PARTIR DU CHASSIS	A PARTIR DEL ARMAZON
601E	VEDERE NOTA	SEE NOTE	VOIR REMARQUE	VEASE NOTA
63G0	COMANDI DIREZIONALI	STEERING SYSTEM	COMMANDE DE DIRECTION	MANDO DE LA DIRECCION
65G3	COMANDI FRENO	BRAKE CONTROLS	COMMANDE DE FREINS	MANDO DEL FRENO
7117	LEVERAGGI	CONTROL LEVERS	TRINGLERIES	TIMONIERA
7211	TELAIO INFERIORE	LOWER MAIN FRAME	CHASSIS INFERIOR	ARMAZON INFERIOR
7215	TELAIO SUPERIORE	UPPER MAIN FRAME	CHASSIS SUPERIOR	ARMAZON SUPERIOR
74G0	BATTERIE, SEDE E RIPARI	BATTERY, SEAT AND SUPPORT	BATTERIE SIEGE ET PROTECTION	
7480	MOTORIDUTTORE TRASLAZIONE	DRIVE MOTOREDUCTION		
7482	MOTORIDUTTORE ROTAZIONE	SWING MOTOREDUCTION		
75GA	IMPIANTO ELETTRICO	ELECTRICAL SYSTEM	SYSTEME ELECTRIQUE	
75G0	COMANDI ELETTRICI	ELECTRIC CONTROLS	COMMANDES ELECTRIQUE	ELEKTRISCHE STEUERUNG
75G1	APPARECCHI ELETTRICI	ELECTRICAL INSTRUMENTS	DISPOSITIFS ELECTRIQUES	ELEKTRISCHE ANZEIGENSTRUMENTE
75G3	CAVI AVVIAMENTO	STARTING CABLES	CABLES DEMARRAGE	STARTERKABEL
75G4	CAVI VARI	VARIOUS CABLES	CABLE DIVERS	MEHRERE KABEL
75G6	APPARECCHI ILLUMINAZIONE	LIGHTS	ECLAIRAGE	BELEUCHTUNG
75G9	TERMOMETRI E MANOMETRI	TEMPERATURE-PRESSURE GAUGES	THERMOMETRES ET MANOMETRES	THERMOMETER UND MANOMETER
7874	BLOCCAGGIO TORRETTA	SUPERSTRUCTURE LOCKING	BLOCAGE SUPERSTRUCTURE	
8079	BENNA SCARICO BILATERALE	BILATERAL DISCHARGE BUCKET	GODET VIDAGE BILATERAL	SEITENKIPPSCHAUFEL
82GA	IMPIANTO IDRAULICO	HYDRAULIC SYSTEM	SYSTEME HYDRAULIQUE	SISTEMA HYDRAULICO
82G0	TUBAZIONI	PIPING		
82G1	FILTRI SERBATOIO OLIO	OIL TANK FILTERS		
82G3	POMPA ATTREZZO	EQUIPMENT PUMP	POMPE OUTIL	
82G4	DISTRIBUTORE ATTREZZO	EQUIPMENT CONTROL VALVE	DISTRIBUTEUR DE L'OUTIL	
82G5	COMANDO DISTRIBUTORE ATTREZZO	CONTROL VALVE DRIVE	COMMANDE DE L'OUTIL	
82G6	TUBAZIONI IMPIANTO IDRAULICO	HYDRAULIC SYSTEM PIPING		
83G0	COFANI	HOODS	CAPOTS	
83G6	RIPARI LATERALI COFANO	HOOD SIDE GUARDS	PROTECTIONS LATERALES CAPOT	
85G0	SEDILE CONDUTTORE	OPERATOR SEAT	SIEGE OPERATEUR	ASIEN TO CONDUCTOR
85G2	SOSTEGNO E RIPARI SEDILE	SEAT SUPPORT AND GUARD	SUPPORT ET PROTECTION SIEGE	
8501	CATENARIA ANTIPOLVERE	SEALED TRACK CHAIN	CHENILLE SCELLEE	
8582	CABINA CORAZZATA	BULLETPROOF CAB	CABINE BLINDEE	
87GA	POSTO GUIDA	OPERATORS COMPARTMENT		
87G0	PARAFANGHI-PEDANE	FENDERS-FLOORS	AILES - PLANCHERS	KOTFLUEGEL-TRITBLECH
87G1	PROTEZIONI INFERIORI	BOTTOM GUARDS	PROTECTION INFERIEURS	PANZERWANNE
8877	STRUTTURA ROPS RIVESTITA			ROPS RAHMEN VERKLEIDET
9005	SOSTITUIZ. RAPIDA OLIO MOTORE	ENGINE OIL QUICK CHANGE		

E

AUXILIARY ATTACHMENT (AND EQUIPMENT) • ORGANI SUSSIDIARI (E ATTREZZI) • ORGANES AUXILIAIRES (ET EQUIPEMENT) •
NEBENAGGREGATE (UND GERÄTE) • GRUPOS AUXILIARES (Y EQUIPO)

P1

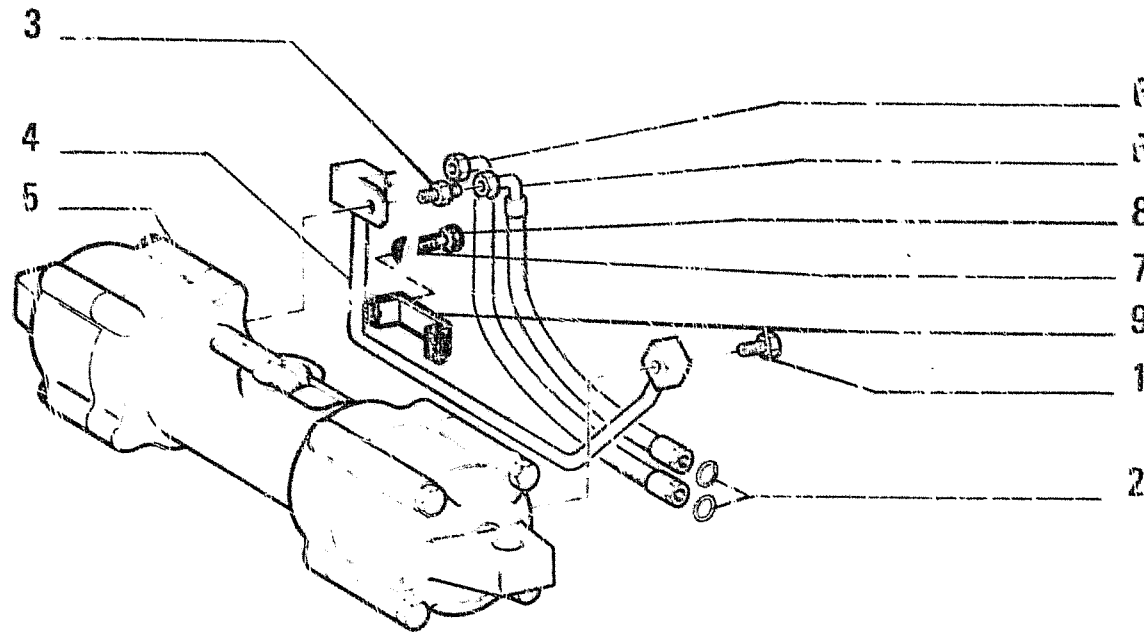

ITEM	PART NUMBER	QTY	TRANS CODE	DESCRIPTION	DESCRIZIONE
1	820953	1	20R	FITTING	RACCORDO
2	45481995	4	133R	SEAL	ROSETTA DI TENUTA
3	79028197	4	20R	FITTING	RACCORDO
4	79028198	1	190T	LINE	TUBAZIONE
5	79029963	1	171C	OPERATING CYLINDER - ASSEMBLY SEE SGR. E3.32/3 C2872	CILINDRO OPERATORE - COMPLETO VEDERE SGR. E3.32/3 C2872
	79099275	1	171C	OPERATING CYLINDER - ASSEMBLY SEE SGR. E3.32/3 D2872	CILINDRO OPERATORE - COMPLETO VEDERE SGR. E3.32/3 D2872
6	79035759	2	192T	HOSE ASSY	TUBO FLESS.C./RACCORDI
7	10571871	2	132N	LOCKWASHER 10,2x2,2	ROSETTA DI SICUREZZA 10,2x2,2
8	11106231	2	40V	SCREW 10x1,5x25	VITE 10x1,5x25
9	79050648	1	223S	BRACKET	STAFFA

OPTIONAL
VARIANTE 30.0127.02.1

C 1616 → tel. n. 250851

HYDRAULIC SYSTEM — IMPIANTO IDRAULICO — SYSTEME HYDRAULIQUE — HYDRAULIKANLAGE
SISTEMA HIDRAULICO

E3.02/9

3

N.T.R. 191 - 20.02.1990

604.01.081.04

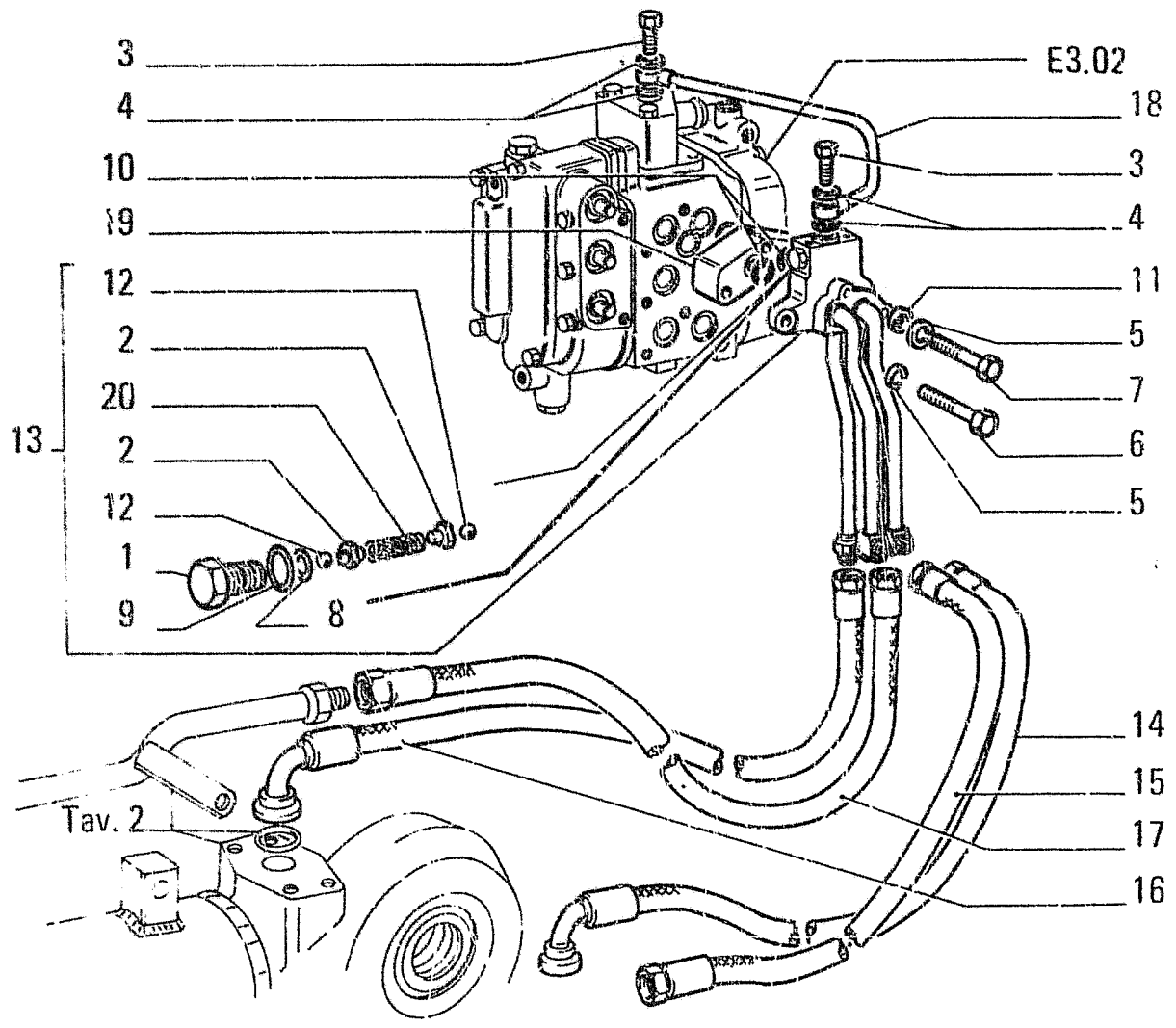

ITEM	PART NUMBER	QTY	TRANS CODE	DESCRIPTION	DESCRIZIONE
1	8291706	1	50T	PLUG	TAPPO
2	8291707	2	147G	SPRING GUIDE	GUIDA DELLA MOLLA
3	10181717	2	20R	FITTING 12x1,5x11	RACCORDO 12x1,5x11
4	10296160	4	133R	SEAL 12,2x18	ROSETTA DI TENUTA 12,2x18
5	10516871	3	132R	LOCKWASHER 10x2,5	ROSETTA DI SICUREZZA 10x2,5
6	11108231	1	40V	SCREW 10x1,5x100	VITE 10x1,5x100
7	11108631	2	40V	SCREW 10x1,5x120	VITE 10x1,5x120
8	14452980	1	158G	O-RING 1,78x9,25	GUARNIZIONE O-R 1,78x9,25
9	14457180	1	158G	O-RING 2,62x13,94	GUARNIZIONE O-R 2,62x13,94
10	14462980	2	158G	O-RING 3,53x20,22	GUARNIZIONE O-R 3,53x20,22
11	14496621	2	131R	WASHER 10,5x21	ROSETTA 10,5x21
12	20063450	2	140S	BALL 6,350	SFERA 6,350
13	76010215	1	9V	SAFETY VALVE - ASSEMBLY	VALVOLA SICUREZZA - COMPLETO
14	76010216	1	192T	HOSE ASSY - LEFT	TUBO FLESS.C/RACCORDI - SINISTRO
15	76010217	1	192T	HOSE ASSY - LEFT	TUBO FLESS.C/RACCORDI - SINISTRO
16	76010218	1	192T	HOSE ASSY - RIGHT	TUBO FLESS.C/RACCORDI - DESTRO
17	76010219	1	192T	HOSE ASSY - RIGHT	TUBO FLESS.C/RACCORDI - DESTRO
18	79021558	1	193T	TUBE	TUBO RIGIDO
19	79021643	1	75D	SPACER	L'ISTANZIALE
20	79022809	1	100M	SPRING	MOLLA

OPTIONAL VARIANTE 30 0127.02.1

D1616 tel. n. 250852 →

HYDRAULIC SYSTEM - IMPIANTO IDRAULICO - SYSTEME HYDRAULIQUE - HYDRAULIKANLAGE - SISTEMA HIDRAULICO

E3.02/10 1

N.T.R. 158 - 13.03.1987
604.01.081.03

Tav. 1

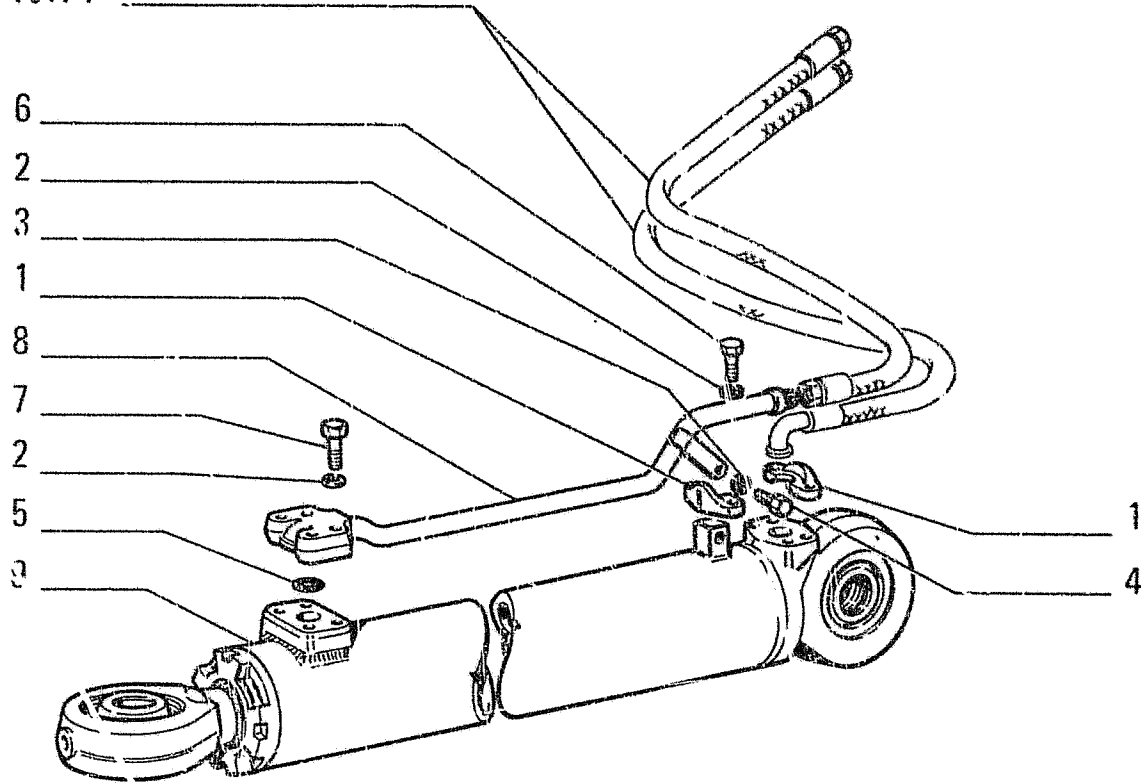

OPTIONAL
VARIANTE 30.0127.02.1

D1616 tel. n. 250852 →

ITEM	PART NUMBER	QTY	TRANS CODE	DESCRIPTION	DESCRIZIONE
1	8297995	4	70F	FLANGE	FLANGIA
2	10516671	16	132R	LOCKWASHER 8,1x2,2	ROSETTA DI SICUREZZA 8,1x2,2
3	10516871	2	132R	LOCKWASHER 10x2,5	ROSETTA DI SICUREZZA 10x2,5
4	11106031	2	4W	SCREW 10x1,5x20	VITE 10x1,5x20
5	14457280	2	158G	O-RING 2,62x15,54	GUARNIZIONE O-R 2,62x15,54
6	16043631	8	40V	SCREW 8x1,25x25	VITE 8x1,25x25
7	16044131	8	40V	SCREW 8x1,25x45	VITE 8x1,25x45
8	76010327	2	193T	TUBE	TUBO RIGIDO
9	76014155	2	171C	OPERATING CYLINDER - ASSEMBLY SEE SGR. E3.32/6 D1619	CILINDRO OPERATORE - COMPLETO VEDERE SGR. E3.32/6 D1619
		2	171C	OPERATING CYLINDER - ASSEMBLY SEE SGR. E3.32/6 C2914	CILINDRO OPERATORE - COMPLETO VEDERE SGR. E3.32/6 C2914
	76015984	2	171C	OPERATING CYLINDER - ASSEMBLY SEE SGR. E3.32/6 D2914	CILINDRO OPERATORE - COMPLETO VEDERE SGR. E3.32/6 D2914
		2	171C	OPERATING CYLINDER - ASSEMBLY SEE SGR. E3.32/6 C2948	CILINDRO OPERATORE - COMPLETO VEDERE SGR. E3.32/6 C2948
	76016703	2	171C	OPERATING CYLINDER - ASSEMBLY SEE SGR. E3.32/6 D2948	CILINDRO OPERATORE - COMPLETO VEDERE SGR. E3.32/6 D2948
	79047305	2	171C	OPERATING CYLINDER - ASSEMBLY SEE SGR. E3.32/2 C1619	CILINDRO OPERATORE - COMPLETO VEDERE SGR. E3.32/2 C1619

HYDRAULIC SYSTEM - IMPIANTO IDRAULICO - SYSTEME HYDRAULIQUE - HYDRAULIKANLAGE -
SISTEMA HIDRAULICO

E3.02/10

2

N.T.R. 191 - 20.02.1990

604.01.081.04

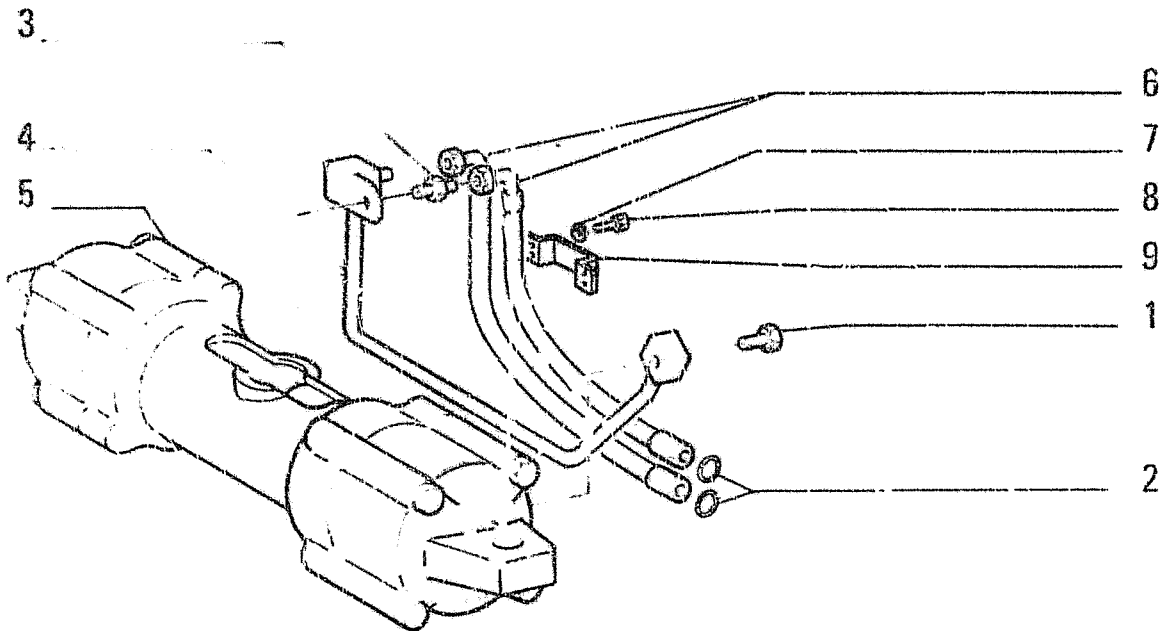

OPTIONAL
VARIANTE 30.0127.02.1

D1616 tel. n. 250852 →

I T E M	PART NUMBER	Q T Y	TRANS CODE	DESCRIPTION	DESCRIZIONE
1	8299534	1	20R	FITTING	RACCORDO
2	45481995	4	133R	SEAL	ROSETTA DI TENUTA
3	79028197	1	20R	FITTING	RACCORDO
4	79028198	1	190T	LINE	TUBAZIONE
5	79029963	1	171C	OPERATING CYLINDER - ASSEMBLY SEE SGR. E3.32/3 C2872	CILINDRO OPERATORE - COMPLETO VEDERE SGR. E3.32/3 C2872
	79099275	1	171C	OPERATING CYLINDER - ASSEMBLY SEE SGR. E3.32/3 D2872	CILINDRO OPERATORE - COMPLETO VEDERE SGR. E3.32/3 D2872
6	76009946	2	192T	HOSE ASSY	TUBO FLESS.C/RACCORDI
7	10571871	2	170M	LOCKWASHER 10,2x2,2	ROSETTA EL. 10,2x2,2
8	11106231	2	40V	SCREW 10x1,5x25	VITE 10x1,5x25
9	79050648	1	225S	BRACKET	STAFFA

HYDRAULIC SYSTEM - IMPIANTO IDRAULICO - SYSTEME HYDRAULIQUE - HYDRAULIKANLAGE -
SISTEMA HIDRAULICO

E3.02/10

3

N.T.R. 191 - 20.02.1990

604.01.081.04

P5

E3.02

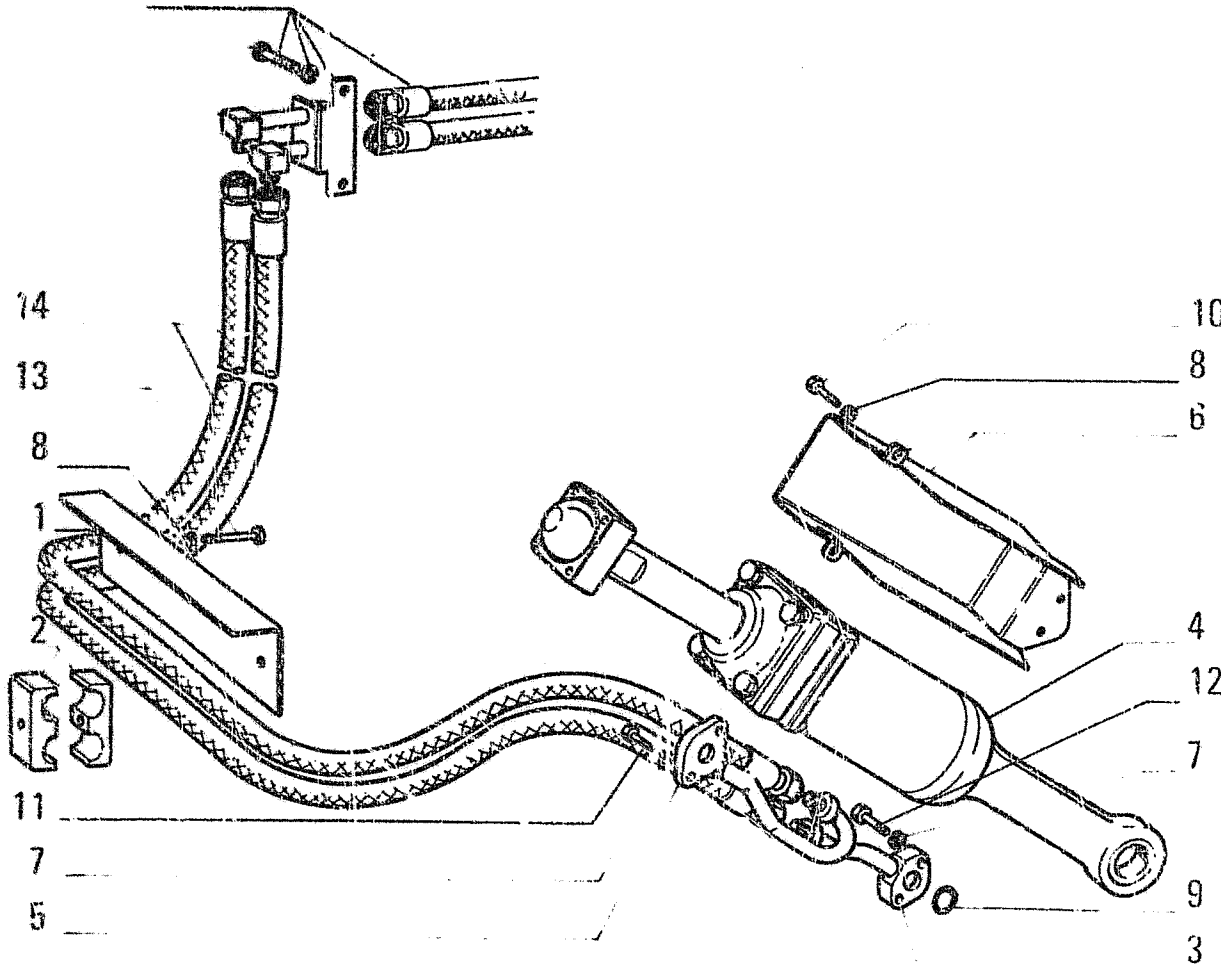

OPTIONAL 30.0405.02.1
 VARIANTE 30.0405.03.1

ITEM	PART NUMBER	QTY	TRANS CODE	DESCRIPTION	DESCRIZIONE
1	283346	1	224P	SHIELD	PROTEZIONE
2	287493	4	78B	FASTENING BLOCK	BLOCCETTO DI FISSAGGIO
3	287802	1	190T	LINE - REAR	TUBAZIONE - POSTERIORE
4	288798	1	171C	OPERATING CYLINDER - ASSEMBLY SEE SGR. E3.32/7	CILINDRO OPERATORE - COMPLETO VEDERE SGR. E3.32/7
	296796	1	171C	OPERATING CYLINDER - ASSEMBLY SEE SGR. E3.32/8	CILINDRO OPERATORE - COMPLETO VEDERE SGR. E3.32/8
5	388986	1	190T	LINE - FRONT	TUBAZIONE - ANTERIORE
6	388988	1		DOOR GUARD	RIPARO
7	10517070	6	132R	LOCKWASHER 12,2x3,1	ROSETTA DI SICUREZZA 12,2x3,1
8	10517071	2	132R	LOCKWASHER 12,2x3,1	ROSETTA DI SICUREZZA 12,2x3,1
9	14403290	2	158G	O-RING 3,53x24,99	GUARNIZIONE O-R 3,53x24,99
10	15540221	2	40V	SCREW 12x1,25x20	VITE 12x1,25x20
11	15540521	2	40V	SCREW 12x1,25x35	VITE 12x1,25x35
12	15540921	2	40V	SCREW 12x1,25x55	VITE 12x1,25x55
13	15540931	2	40V	SCREW 12x1,25x55	VITE 12x1,25x55
14	79035757	2	192T	HOSE ASSY	TUBO FLESS.C/RACCORDI

HYDRAULIC SYSTEM - IMPIANTO IDRAULICO - SYSTEMA HIDRAULIQUE - HYDRAULIKANLAGE -
 SISTEMA HIDRAULICO

E3.02/11

N.T.R. 191 - 20.02.1990

604.01.081.04

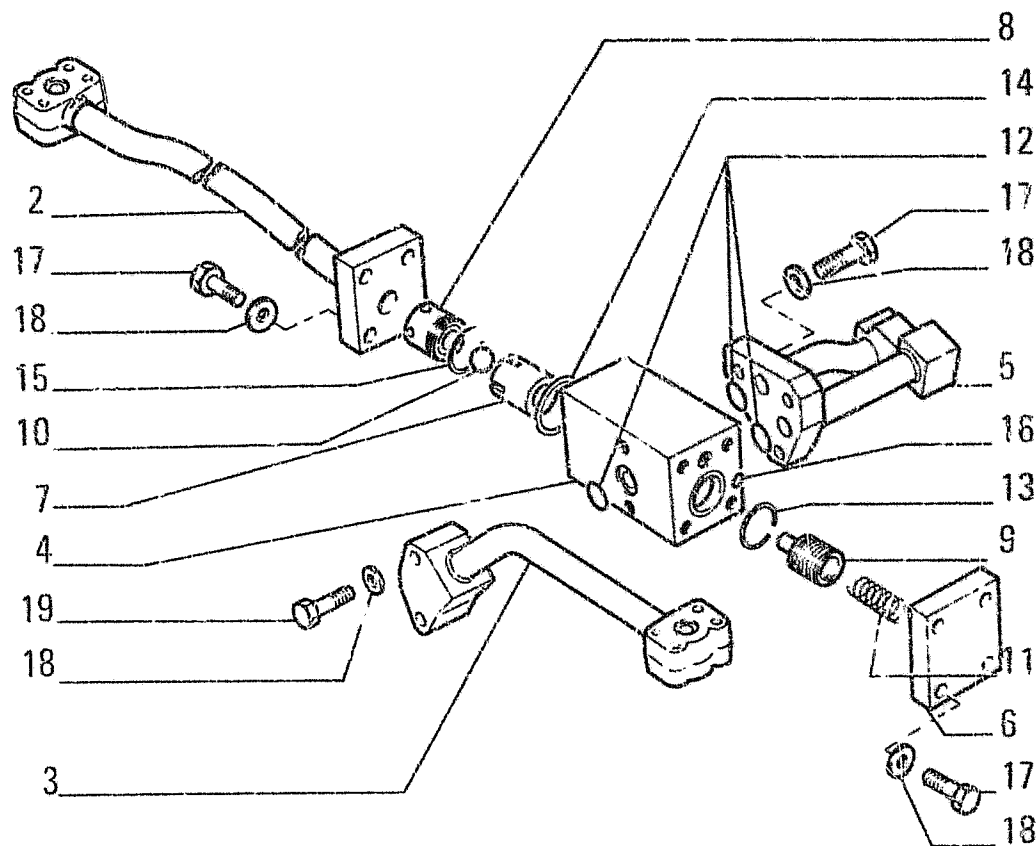

OPTIONAL 30.1107.01.1
VARIANTE

ITEM	PART NUMBER	QTY	TRANS CODE	DESCRIPTION	DESCRIZIONE
2	79039814	1	190T	LINE - FRONT RIGHT	TUBAZIONE - ANTERIORE DESTRO
	79039815	1	190T	LINE - FRONT LEFT	TUBAZIONE - ANTERIORE SINISTRO
3	79031035	1	190T	LINE - REAR RIGHT	TUBAZIONE - POSTERIORE DESTRO
	79031036	1	190T	LINE - REAR LEFT	TUBAZIONE - POSTERIORE SINISTRO
4	79031046	1	300C	BODY - RIGHT	CORPO - DESTRO
	79031047	1	300C	BODY - LEFT	CORPO - SINISTRO
5	76010328	1	190T	LINE - SIDE RIGHT	TUBAZIONE - LATERALE DESTRO
	76010329	1	190T	LINE - SIDE LEFT	TUBAZIONE - LATERALE SINISTRO
6	79031040	2	70F	FLANGE	FLANGIA
7	79031050	2	132P	PISTON	PISTONE
8	79031051	2	75S	BALL SOCKET	SEDE SFFRICA
9	79031049	2	132P	PISTON	PISTONE
10	20063060	2	140S	BALL 22,226	SFERA 22,226
11	79031048	2	100M	SPRING	MOLLA
12	14457480	6	158G	O-RING 2,62x18,72	GUARNIZIONE O-R 2,62x18,72
13	14458280	2	158G	O-RING 2,62x31,42	GUARNIZIONE O-R 2,62x31,42
14	14459180	2	158G	O-RING 2,62x45,69	GUARNIZIONE O-R 2,62x45,69
15	14463180	2	158G	O-RING 3,53x23,39	GUARNIZIONE O-R 3,53x23,39
16	14452980	2	158G	O-RING 1,78x9,25	GUARNIZIONE O-R 1,78x9,25
17	11106631	20	40V	SCREW 10x1,5x35	VITE 10x1,5x35
18	10571871	24	131R	WASHER 10,2x2,2	ROSETTA 10,2x2,2
19	11107331	4	40V	SCREW 10x1,5x55	VITE 10x1,5x55

HYDRAULIC SYSTEM - IMPIANTO IDRAULICO - SYSTEME HYDRAULIQUE - HYDRAULIKANLAGE --
SISTEMA HIDRAULICO

E3.02 12

N.T.N. 200-15.10.1990

604.01.031.05

P7

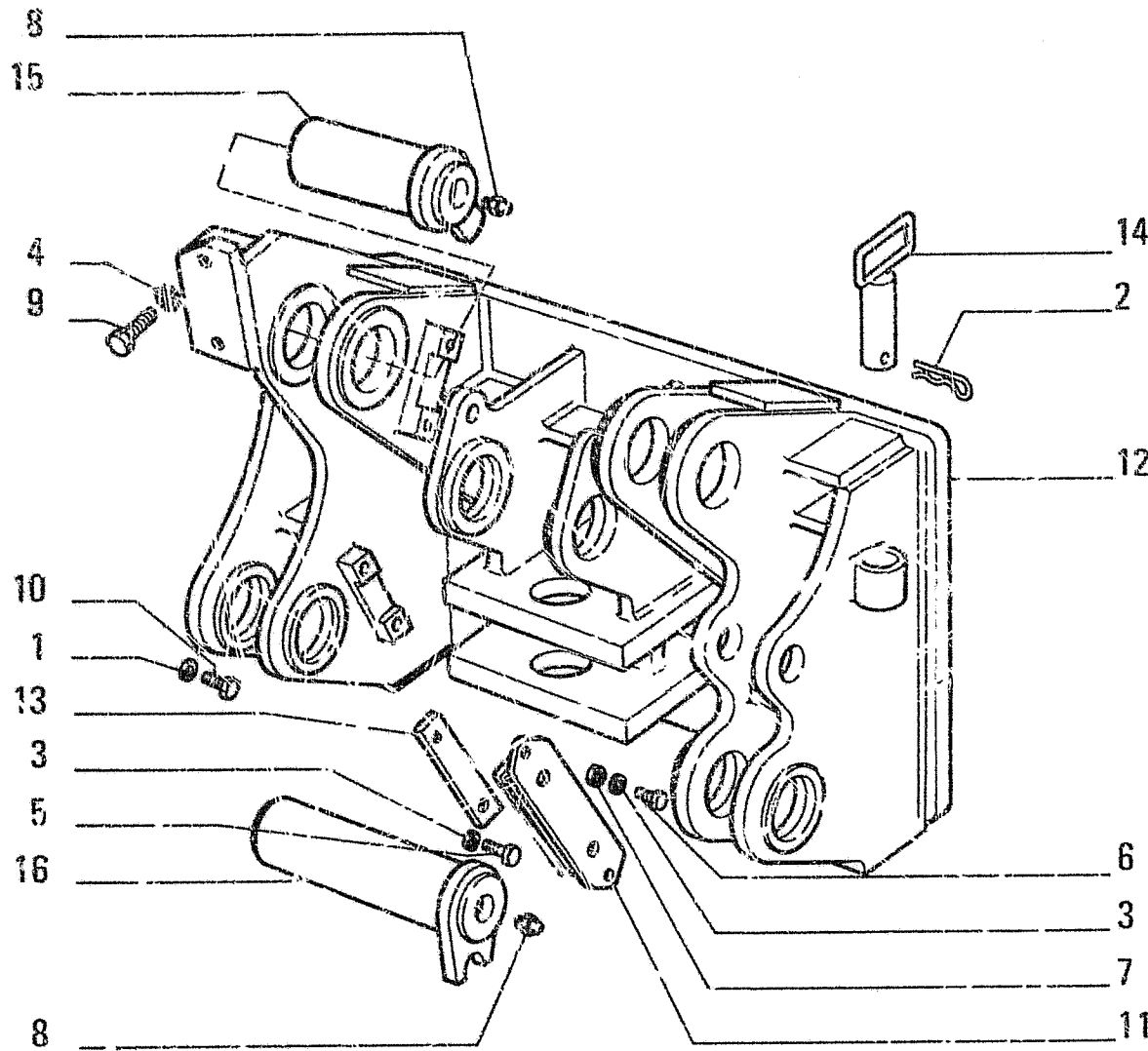

OPTIONAL 30.0920.14.1
VARIANTE

ITEM	PART NUMBER	QTY	TRANS CODE	DESCRIPTION	DESCRIZIONE
1	595582	1	131R	WASHER	ROSETTA
2	8268534	2	202S	SPRING PIN	SPINA ELASTICA
3	10571871	10	132R	LOCKWASHER 10,2x2,2	ROSETTA DI SICUREZZA 10,2x2,2
4	10572371	18	132R	LOCKWASHER 20,2x4	ROSETTA DI SICUREZZA 20,2x4
5	11106031	8	40V	SCREW 10x1,5x20	VITE 10x1,5x20
6	11106231	2	40V	SCREW 10x1,5x25	VITE 10x1,5x25
7	11701721	2	10D	NUT 10x1,5x8	DADO 10x1,5x8
8	13407211	5	60I	GREASE FITTING 10x1	INGRASSATORE 10x1
9	15828431	18	40V	SCREW 20x1,5x65	VITE 20x1,5x65
10	16322921	1	40V	SCREW 10x1,25x12	VITE 10x1,25x12
11	79014002	1	60T	BLOCK	TASSELLO
12	79029304	1	105P	PLATE	PIASTRA
13	79029322	4	110P	PLAQUE	PIASTRINA
14	79029327	2	80P	PIN	PERNO
15	79029335	4	80P	PIN	PERNO
16	79030901	1	80P	PIN	PERNO

IMPLEMENT MOUNTS - SUPPORTI ATTREZZI - SUPPORTS DES OUTILS -
HALTERUNG F. ARBEITSGERAETE - SOPORTES DE UTILES -

1
E3.05
N.T.R. 152 - 28.11.1986
604.01.081 02

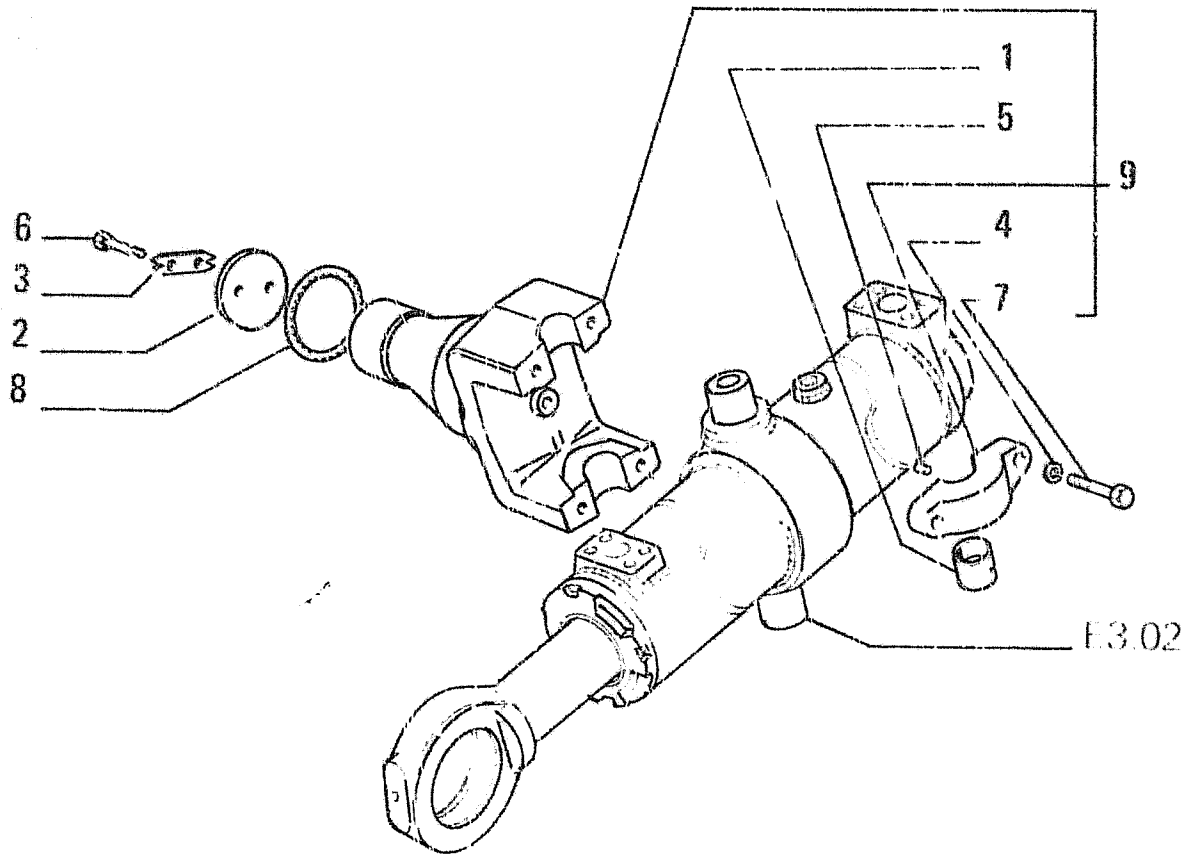

ITEM	PART NUMBER	QTY	TRANS CODE	DESCRIPTION	DESCRIZIONE
1	8285377	2	95B	BUSHING	BOCCOLA
2	8285378	2	60D	DISC	DISCO
3	8285379	2	113P	LOCKPLATE	PIASTRINA DI SICUREZZA
4	10517071	4	132R	LOCKWASHER 12,2x3,1	ROSETTA O' SICUREZZA 12,2x3,1
5	10839510	2	93G	DOWEL 6x9	GRANO 6x9
6	11112431	4	40V	SCREW 12x1,75x30	VITE 12x1,75x30
7	11113331	4	40V	SCREW 12x1,75x55	VITE 12x1,75x55
8	14464980	2	158G	O-RING 3,53x66,27	GUARNIZIONE O-R 3,53x66,27
9	79035555	2	85F	YOKE - ASSEMBLY	FORCELLA - COMPLETO

DOZER BLADE CYLINDER MOUNTS — SUPPORTI CILINDRI APRIPISTA — SUPPORTS DE CYLINDRES DE LAME
 DOZER — LAGERUNG DER ZYLINDER DES PLANIERGERAETES — SOPORTES DE GATOS DEL ABRETRO
 CHAS

E3.06

N.T.R. 205 - 30.09.1991
 604.01.081.06

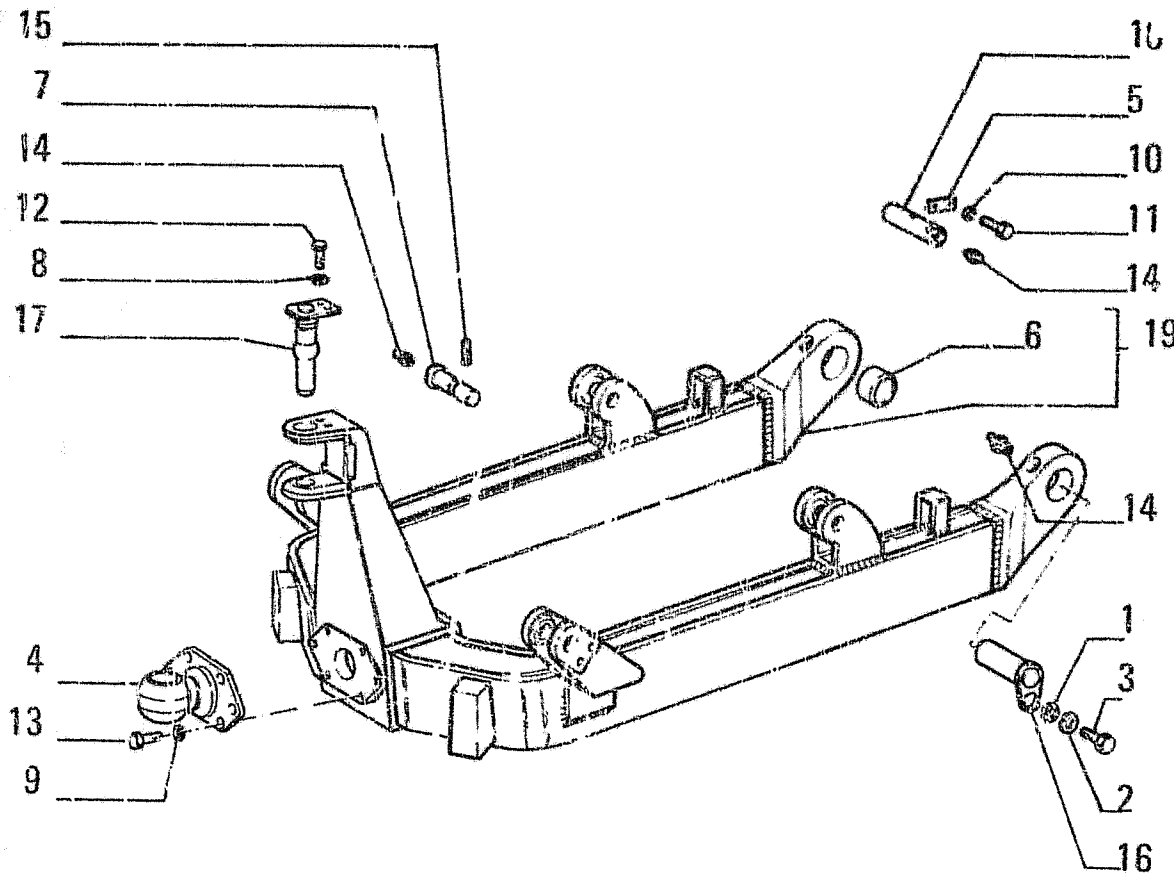

OPTIONAL
VARIANTE 30.1003.02.1

ITEM	PART NUMBER	QTY	TRANC CODE	DESCRIPTION	DESCRIZIONE
1	8296969	2	75D	SPACER	DISTANZIALE
2	8296970	2	131R	WASHER	ROSETTA
3	8296975	2	40V	SCREW	VITE
4	8297617	1	300S	SUPPORT C2913	SUPPORTO C2913
	79078990	1	300S	SUPPORT D2913	SUPPORTO D2913
5	8297638	2	110P	PLAQUE	PLASTRINA
6	8298667	2	95B	BUSHING	BICCOLA
7	8298671	2	80P	PIN	PERNO
8	10517071	2	132R	LOCKWASHER 12,2x3,1	ROSETTA DI SICUREZZA 12,2x3,1
9	10517171	6	132R	LOCKWASHER 14,2x3,5	ROSETTA DI SICUREZZA 14,2x3,5
10	10571871	4	132R	LOCKWASHER 10,2x2,2	ROSETTA DI SICUREZZA 10,2x2,2
11	11106231	4	40V	SCREW 10x1,5x25	VITE 10x1,5x25
12	11112431	2	40V	SCREW 1,2x1,75x30	VITE 1,2x1,75x30
13	11115831	6	40V	SCREW 14x2x40 C2913	VITE 14x2x40 C2913
	11116031	6	40V	SCREW 14x2x45 D2913	VITE 14x2x45 D2913
14	13407211	6	60I	GREASE FITTING 10x1	INGRASSATORE 10x1
15	14604870	2	200S	PIN 6,4x60	SPINA 6,4x60
16	79027224	2	80P	PIN	PERNO
17	79031844	1	80P	PIN	PERNO
18	79048266	2	80P	PIN	PERNO
19	79048346	1	81A	C-FRAME - ASSEMBLY	ARCONE - COMPLETO

DOZER BLADE LIFTING ARMS - BRACCI SOLLEVAMENTO APRIPISTA - BRAS DE LEVAGE DE
LAME DOZER - HUBARME FUER LADESCHAUFEL - BRAZOS DE ELEVACION DE LA PALA

2

E3.10

N.T.R. 191 - 20.02.1990

604.01.081.04

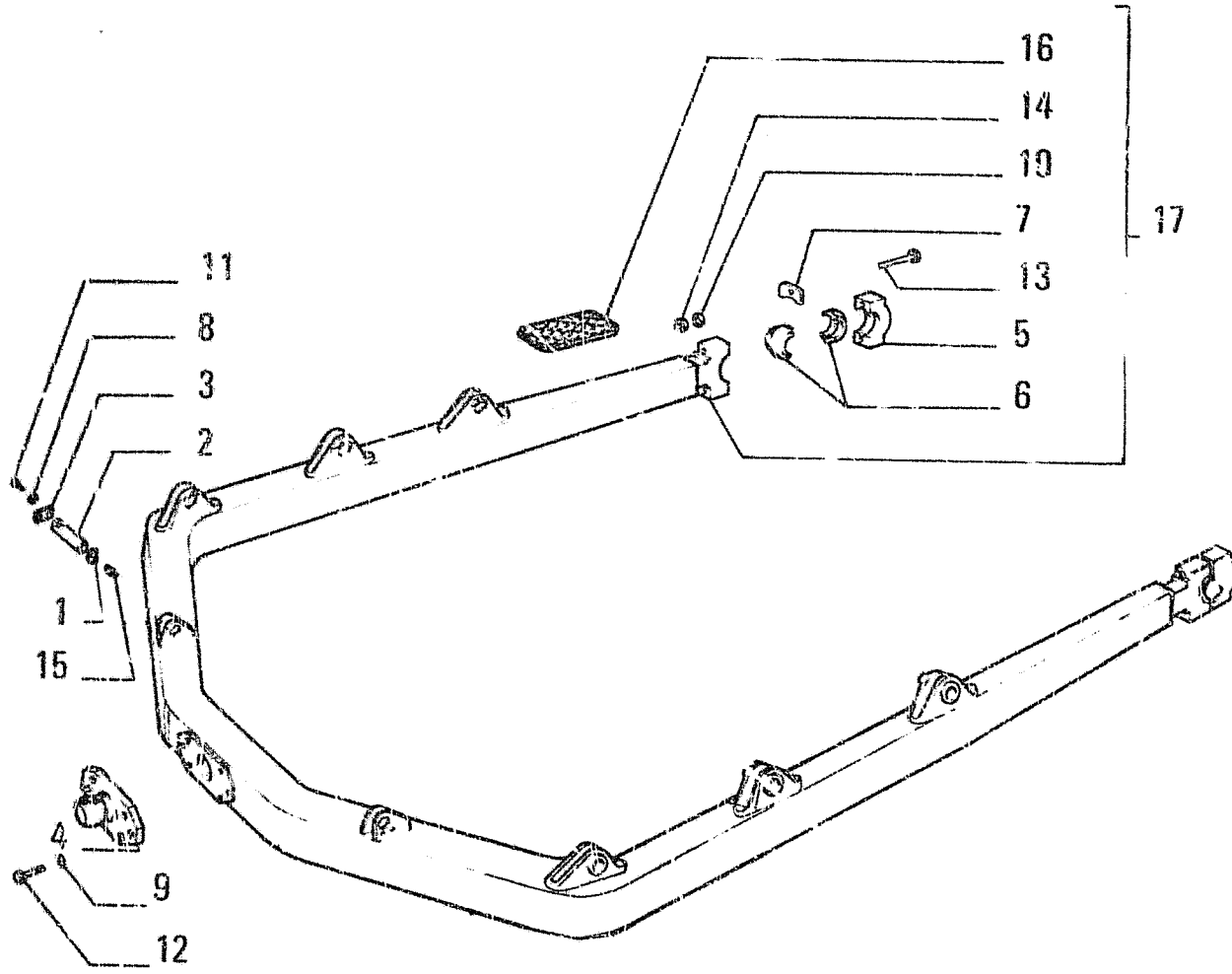

OPTIONAL 30.1001 06 1
VARIANTE

ITEM	PART NUMBER	QTY	TRANS CODE	DESCRIPTION	DESCRIZIONE
1	8280842	4	45A RING		ANELLO
2	8280936	2	80P PIN		PERNO
3	8289428	2	110P PLAQUE		PIASTRINA
4	8297617	1	300S SUPPORT C2913		SUPPORTO C2913
	79078990	1	300S SUPPORT D2913		SUPPORTO D2913
5	8298657	2	300S SUPPORT		SUPPORTO
6	8298653	2	95S HALF PUSHING		SEMIBOCCOLA
7	8298660	4	110P PLAQUE		PIASTRINA
8	10517071	4	131R WASHER 12,2x3,1		ROSETTA 12,2x3,1
9	10517171	6	132R LOCKWASHER 14,2x3,5		ROSETTA DI SICUREZZA 14,2x3,5
10	10517271	4	131R WASHER 16,2x4		ROSETTA 16,2x4
11	11112431	4	40V SCREW 12x1,75x30		VITE 12x1,75x30
12	11116031	6	40V SCREW 14x2x45		VITE 14x2x45
13	11120631	4	40V SCREW 16x1,5x135		VITE 16x1,5x135
14	12163327	4	10D NUT 16x2x13		DADO 16x2x13
15	13407211	2	60I GREASE FITTING 10x1		INGRASSATORE 10x1
16	79021915	2	105P PLATE		PIASTRA
17	79036068	1	81A C-FRAME - ASSEMBLY		ARCONE - COMPLETO

DOZER BLADE LIFTING ARMS - BRACCI SOLLEVAMENTO APRIPISTA - BRAS DE LEVAGE DE LAME DOZER 2
HUBARME FUER PLANIERGERAETE - BRAZOS DE ELEVACION DEL ABRETROCHAS

E3.10 1
N.T.R. 191 - 20.02.1990
604.01.081.04

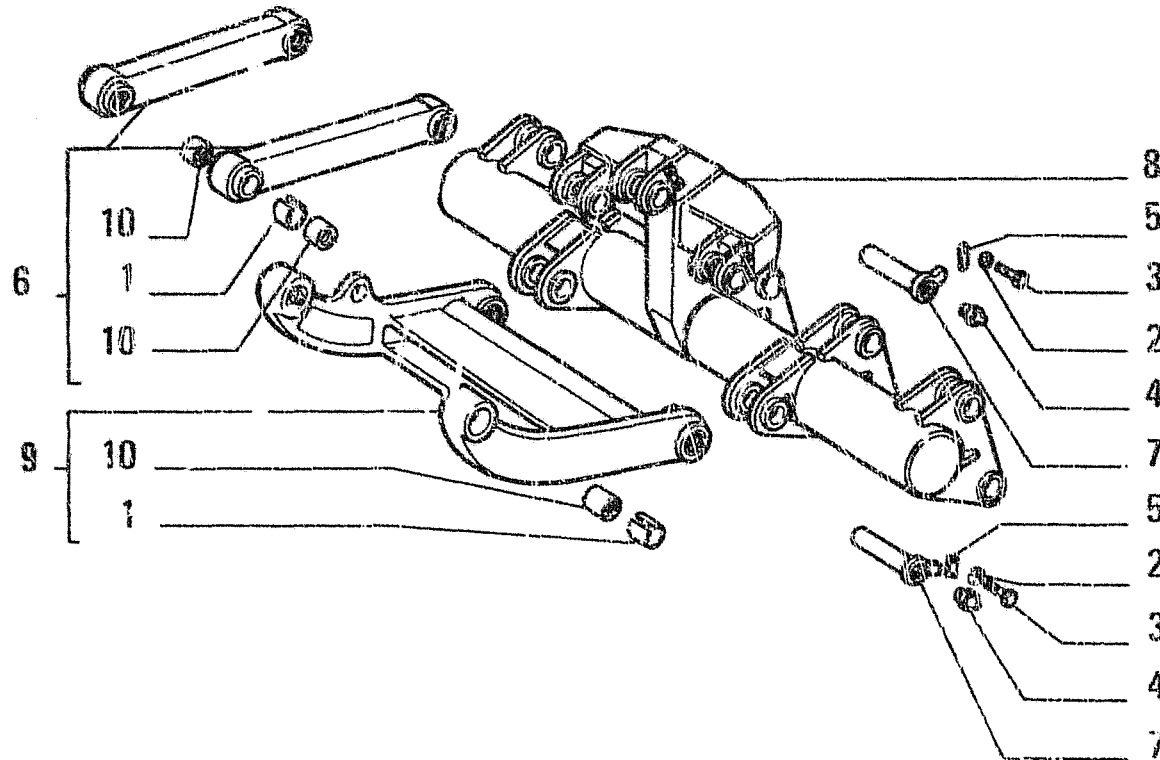

ITEM	PART NUMBER	QTY	TRANS CODE	DESCRIPTION	DESCRIZIONE
1	8288832	16	120G	GASKET	GUARNIZIONE PIANA
2	10571871	10	132R	LOCKWASHER 10,2x2,2	ROSETTA DI SICUREZZA 10,2x2,2
3	11106031	10	40V	SCREW 10x1,5x20	VITE 10x1,5x20
4	13407211	5	60I	GREASE FITTING 10x1	INCRASSATORE 10x1
5	79029322	5	110P	PLAQUE	PIASTRINA
6	79029332	2	50B	LINK - ASSEMBLY	BIELLA - COMPLETO
7	79029335	5	80P	PIN	PERNO
8	79029380	1	300C	BODY	CORPO
9	79029412	1	300S	SUPPORT - ASSEMBLY	SUPPORTO - COMPLETO
10	79042629	2	95B	BUSHING	BOCCOLA

OPTIONAL 30.0920.14.1
VARIANTE

IMPLEMENT LIFTING ARMS - BRACCI SOLLEVAMENTO ATTREZZI - BRAS DE LEVAGE
DES OUTILS - HUBARME FUER ARBEITSGERAETE - BRAZOS DE ELEVACION DE UTILES

1

E3.10/2

N.T.R. 200 - 15.10.1990

604.01.081.05

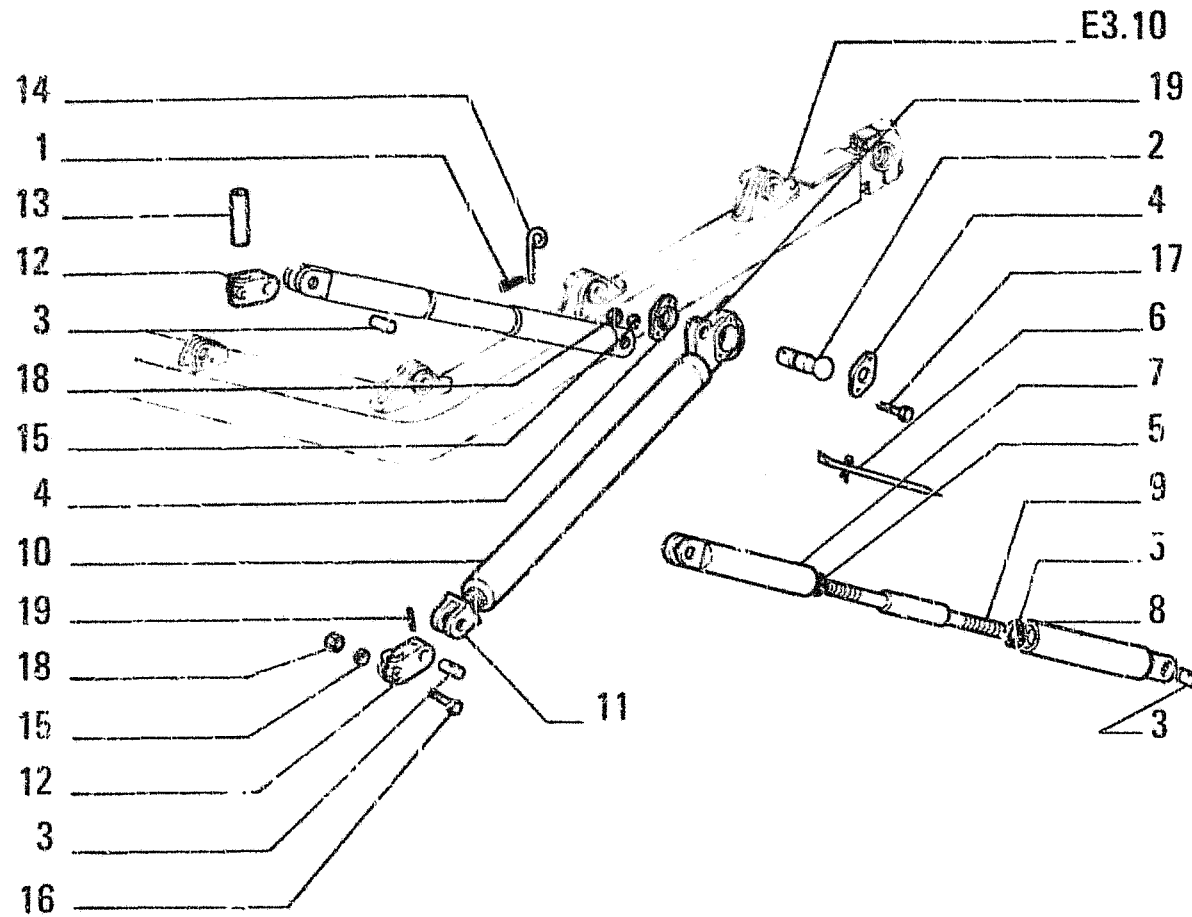

OPTIONAL
VARIANTE 30.1011.05.1

ITEM	PART NUMBER	QTY	TRANS CODE	DESCRIPTION	DESCRIZIONE
1	567406	2	270C	COTTER PIN	COPIGLIA
2	8285297	2	80P	PIN	PERNO
3	8285298	6	80P	PIN	PERNO
4	8285330	4	70F	FLANGE	FLANGIA
5	8288832	4	120G	GASKET	GUARNIZIONE PIANA
6	8296559	2	45L	LEVER	LEVA
7	8298761	2	32M	ADJUSTMENT SLEEVE - FRONT	MANICOTTO DI REGOLAZIONE - ANTERIORE
8	8298762	2	32M	ADJUSTMENT SLEEVE - REAR	MANICOTTO DI REGOLAZIONE - POSTERIORE
9	8298766	2	141T	THREADED TIEROD	TIRANTE FILETTATO
10	8298768	2	244P	STRUT	PUNTONE
11	8298770	2	61E	END - FRONT	ESTREMITÀ - ANTERIORE
12	8298771	4	225S	BRACKET	STAFFA
13	8298772	4	80P	PIN	PERNO
14	9299999	2	202S	SPRING PIN	SPINA ELASTICA
15	10571971	8	132R	LOCKWASHER 12,2x2,5	FIOSSETTA DI SICUREZZA 12,2x2,5
16	11113631	4	40V	SCREW 12x1,75x70	VITE 12x1,75x70
17	11113731	4	40V	SCREW 12x1,75x75	VITE 12x1,75x75
18	11702921	8	10D	NUT 12x1,75x10	DADO 12x1,75x10
19	13914070	6	202S	SPRING PIN 8x60	SPINA ELASTICA 8x60

DOZER BLADE LIFTING ARMS — BRACCI SOLLEVAMENTO APRIPISTA — BRAS DE LEVAGE DE LAME
DOZER — HUBARME FUER PLANIERGERAETE — BRAZOS DE ELEVACION DEL ABRETROCHAS

2

E3.10/3

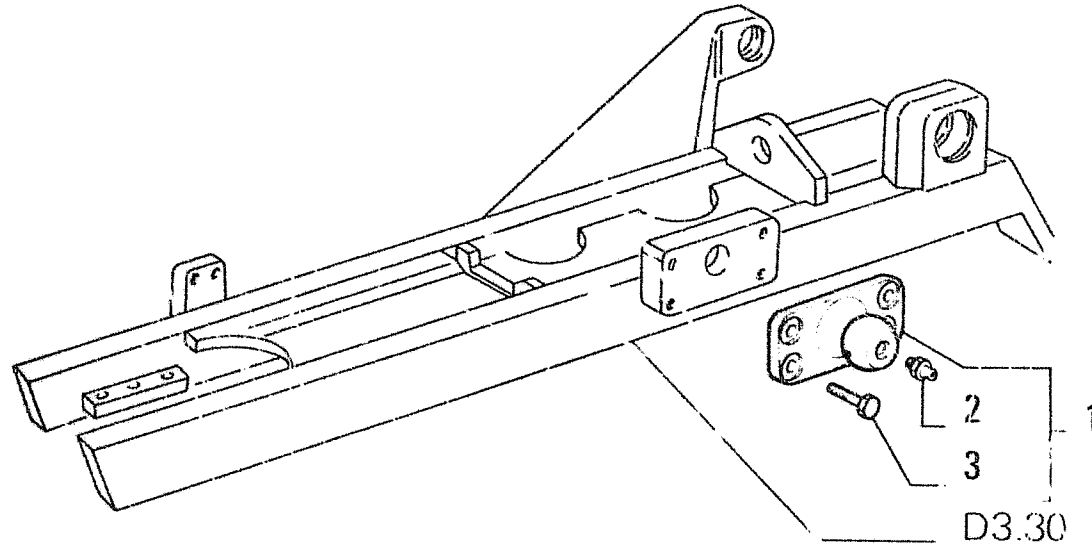

ITEM	PART NUMBER	QTY	TRANS CODE	DESCRIPTION	DESCRIZIONE
1	8298700	2	3005	SUPPORT - ASSEMBLY (*)	SUPPORTO - COMPLETO (*)
	79041288	2	300S	SUPPORT - ASSEMBLY (1*)(2*)	SUPPORTO - COMPLETO (1*)(2*)
2	13407211	2	60I	GREASE FITTING (*) (1*)(2*) 10x1	INGRASSATORE (*) (1*)(2*) 10x1
3	14271530	8	40V	SCREW (*) (1*)(2*) 18x1,5x40	VITE (*) (1*)(2*) 18x1,5x40
			469P	FOR SPECIAL EQUIPMENT 30.1095.07.1	PER VARIANTE 30.1095.07.1
			469P	FOR SPECIAL EQUIPMENT 30.0405.03.1	PER VARIANTE 30.0405.03.1
			469P	FOR SPECIAL EQUIPMENT 30.0405.02.1	PER VARIANTE 30.0405.02.1

DOZER BLADE LIFTING ARMS - BRACCI SOLLEVAMENTO APPRIPISTA - BRAS DE LEVAGE DE LAME
 DOZER - HUBARME FUER PLANIERGERAETE - BRAZOS DE ELEVACION DEL ABRETROCHAS

2

E3.10/4

N.T.R. 191 - 20.02.1990

604.01.081.04

P14

5-1A

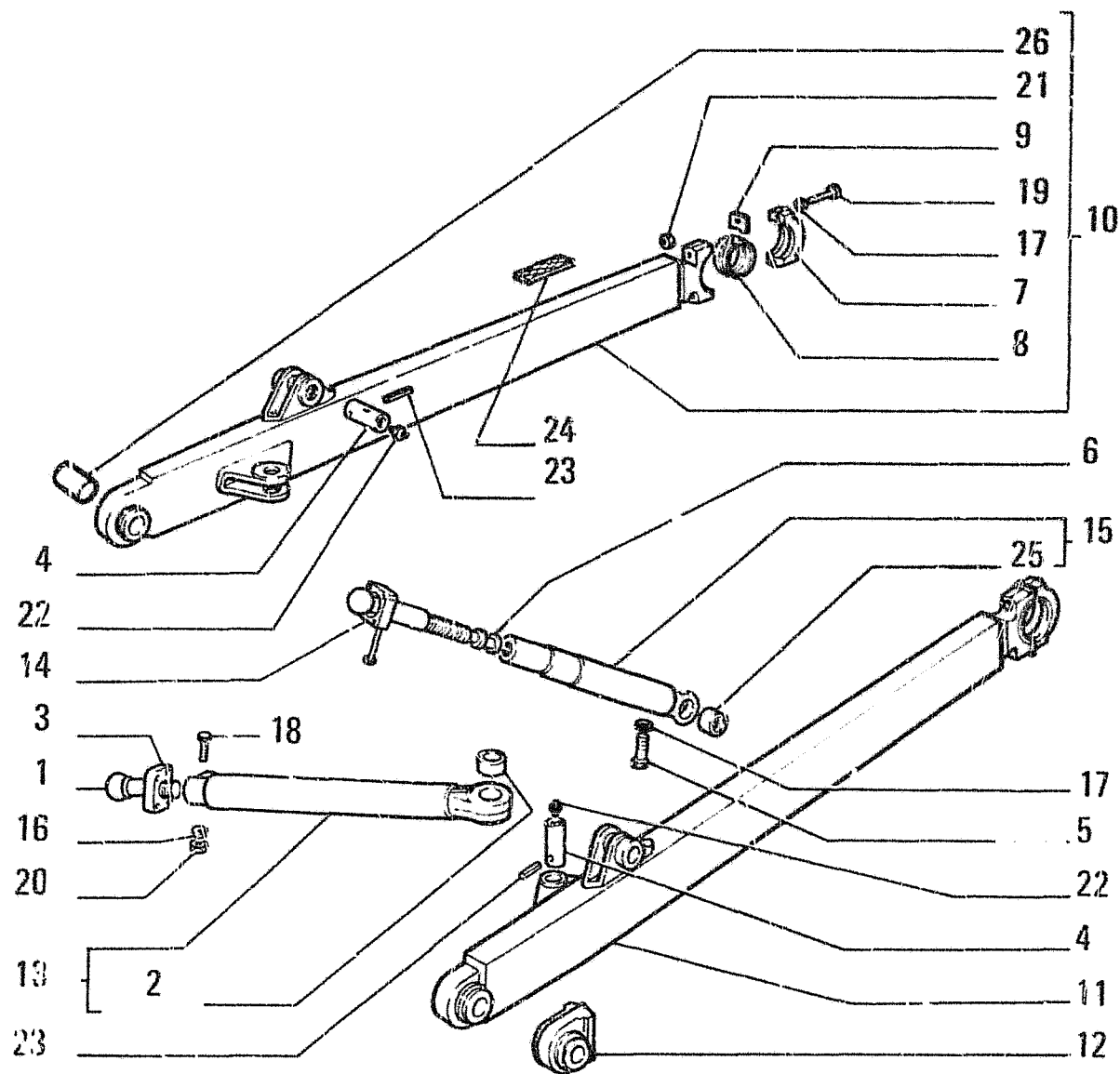

OPTIONAL
VARIANTE 30.1040.05.1

ITEM	PART NUMBER	QTY	TRANS CODE	DESCRIPTION	DESCRIZIONE
1	8280310	2	40V	SCREW	VITE
2	8283007	1	95B	BUSHING	BOCCOLA
3	8283053	2	165S	ARTICULATION	SNODO
4	8285654	4	80P	PIN	PERNO
5	8295634	1	40V	SCREW - SIDE	VITE - LATERALE
6	8295731	1	120G	GASKET	GUARNIZIONE PIANA
7	8298657	1	79L	REST	LUNETTA
8	8298659	1	96S	HALF BUSHING - REAR	SEMIBOCCOLA - POSTERIORE
9	8298660	2	110P	PLAQUE	PIASTRINA
10	8298703	1	130B	BOOM - RIGHT ASSEMBLY	BRACCIO - DESTRO COMPLETO
11	8298705	1	130B	BOOM - LEFT ASSEMBLY	BRACCIO - SINISTRO COMPLETO
12	8298713	2	300S	SUPPORT - FRONT TO BE WELDED	SUPPORTO - ANTERIORE DA SALDARE
13	8298716	2	142T	TIEROD - ASSEMBLY	TIRANTE - COMPLETO
14	8298721	1	142T	TIEROD - SIDE	TIRANTE - LATERALE
15	8298724	1	142T	TIEROD - SIDE ASSEMBLY	TIRANTE - LATERALE COMPLETO
16	10517071	4	132R	LOC. WASHER 12,2x3,1	ROSETTA DI SICUREZZA 12,2x3,1
17	10517271	2	132R	LOCKWASHER 16,2x4	ROSETTA DI SICUREZZA 16,2x4
18	11113431	4	40V	SCREW 12x1,75x60	VITE 12x1,75x60
19	11120637	2	40V	SCREW 16x1,5x135	VITE 16x1,5x135
20	11702921	4	10D	NUT 12x1,75x10	DADO 12x1,75x10
21	12163327	2	10D	NUT 16x2x13	DADO 16x2x13
22	13407211	4	60I	GREASE FITTING 10x1	INGRASSATORE 10x1
23	14610970	4	202S	SPRING PIN 16x80	SPINA ELASTICA 16x80
24	79021915	2	105P	PLATE	PIASTRA
25	79025284	1	95B	BUSHING	BOCCOLA
26	8270124	1	95B	BUSHING	BOCCOLA

DOZER BLADE LIFTING ARMS - BRACCI SOLLEVAMENTO APRIPISTA - BRAS DE LEVAGE DE LAME
DOZER - HUBARME FUER PLANIERGERAETE - BRAZOS DE ELEVACION DEL ABRETROCHAS

2

E3.10/5

N.T.R. 205 - 30.09.1991
604.01.081.06

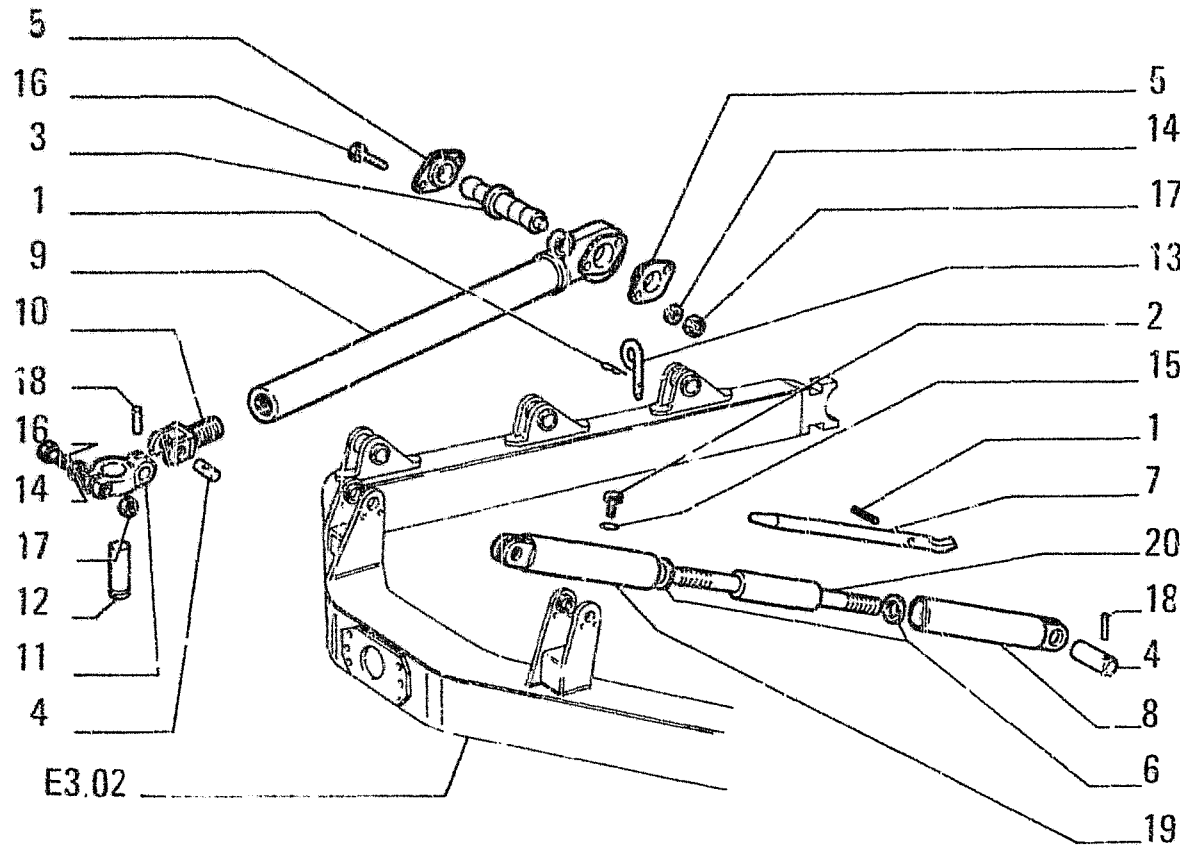

OPTIONAL 30.1124.05.1
VARIANTE

ITEM	PART NUMBER	QTY	TRANS CODE	DESCRIPTION	DESCRIZIONE
1	567406	2	270C	COTTER PIN	COPIGLIA
2	8280337	1	40V	SCREW	VITE
3	8285297	1	80P	PIN	PERNO
4	8285298	3	80P	PIN	PERNO
5	8285330	2	70F	FLANGE	FLANGIA
6	8289832	2	120G	GASKET	GJARNIZIONE PIANA
7	8296559	1	45L	LEVER	LEVA
8	8298762	1	62E	TIEROD HEAD - REAR	ESTREMITÀ DEL TIRANTE - POSTERIORE
9	8298768	1	141T	THREADED TIEROD - LOWER	TIRANTE FILETTATO - INFERIORE
10	8298770	1	62E	TIEROD HEAD - FRONT	ESTREMITÀ DEL TIRANTE - ANTERIORE
11	8298771	2	104A	EQUIPMENT MOUNTING	ATTACCO PER ATTREZZI
12	8298772	2	80P	PIN	PERNO
13	8299999	1	200S	PIN	SPINA
14	10571971	4	132R	LOCKWASHER 12,2x2,5	ROSETTA DI SICUREZZA 12,2x2,5
15	10572171	1	132R	LOCKWASHER 16x3,5	ROSETTA DI SICUREZZA 16x3,5
16	11113631	4	40V	SCREW 12x1,75x70	VITE 12x1,75x70
17	11702921	4	10D	NUT 12x1,75x10	DADO 12x1,75x10
18	13914070	4	202S	SPRING PIN 8x60	SPINA ELASTICA 8x60
19	79035102	1	62E	TIEROD HEAD - FRONT	ESTREMITÀ DEL TIRANTE - ANTERIORE
20	79035106	1	141T	THREADED TIEROD	TIRANTE FILETTATO

DOZER BLADE LIFTING ARMS - BRACCI SOLLEVAMENTO APPRIPISTA - BRAS DE LEVAGE DE LAME
DOZER - HUBARME FUER PLANIERGERAETE - BRAZOS DE ELEVACION DEL ABRETROCHAS

2

E3.10/6

1

N.T.P. 114 - 16.01.1984
604.01.081.01

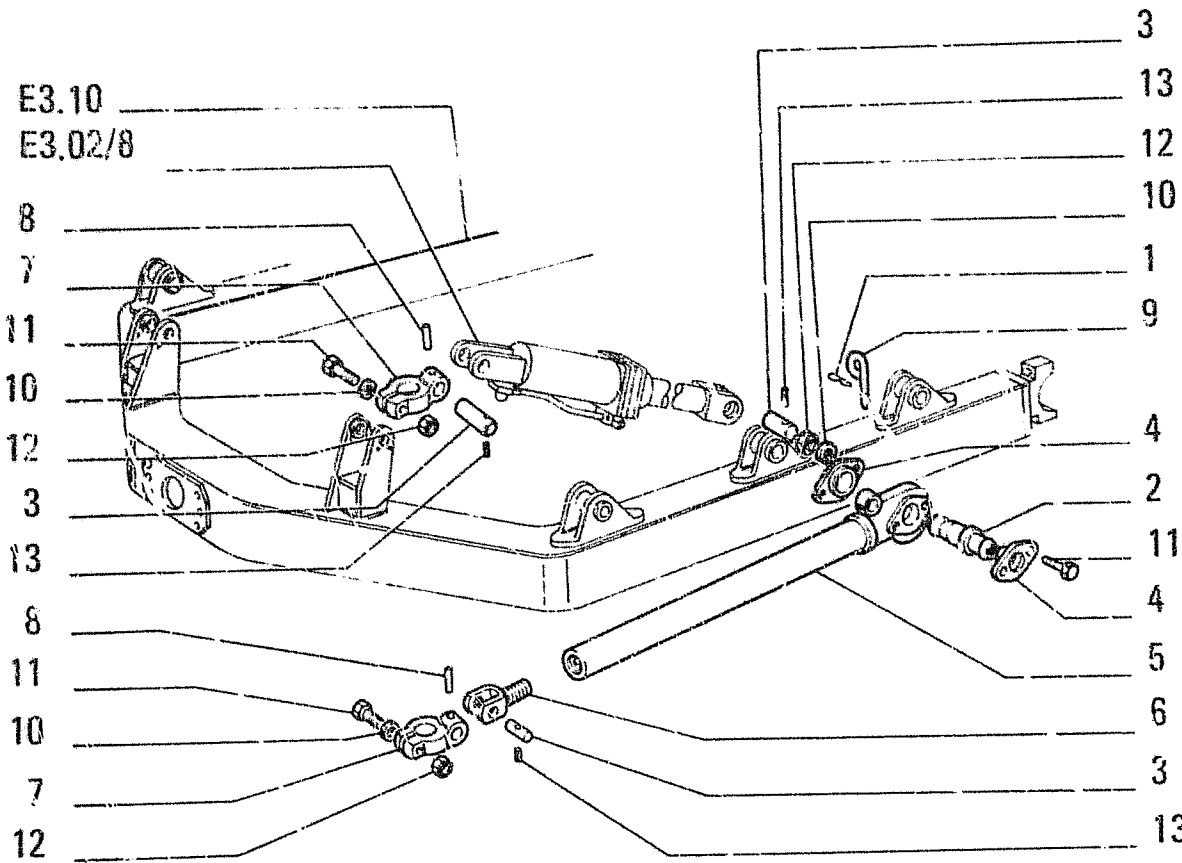

OPTIGNAL 30.1124.05.1
VARIAITE

ITEM	PART NUMBER	QTY	TRANS CODE	DESCRIPTION	DESCRIZIONE
1	567406	1	270C	COTTER PIN	COPIGLIA
2	8285297	1	80P	PIN	PERNO
3	8285298	3	80P	PIN	PERINO
4	8285330	2	70F	FLANGE	FLANGIA
5	8298768	1	141T	THREADED TIL ROD - LOWER	TIRANTE FILETTATO - INFERIORE
6	8298770	1	62E	TIEROD HEAD - FRONT	ESTREMITÀ DEL TIRANTE - ANTERIORE
7	8298771	2	104A	EQUIPMENT MOUNTING	ATTACCO PER ATTREZZI
8	8298772	2	80P	PIN	PERNO
9	8299999	1	200S	PIN	SPINA
10	10571971	4	132R	LOCKWASHER 12,2x2,5	ROSETTA DI SICUREZZA 12,2x2,5
11	11113631	4	40V	SCREW 12x1,75x70	VITE 12x1,75x70
12	11702921	4	10D	NUT 12x1,75x10	DADO 12x1,75x10
13	13914070	3	202S	SPRING PIN 8x60	SPINA ELASTICA 8x60

DOZER BLADE LIFTING ARMS - BRACCI SOLLEVAMENTO APRIPISTA - BRAS DE LEVAGE DE LAME D'O-
ZER - HUBARME FUER PLANIERGERAETE - BRAZOS DE LLEVACION DEL ABRETROCHAS -

E3.10/3

2

DESIGNAZIONE BASE	BASIC DESIGNATION	DESIGNATIONS-BASES	GRUNDBEZEICHNUNGEN	DEROMINACIONES BASE
9007	IMP. PROTEZIONE MOTORE	ENGINE PROTECTION		
9016	ALLESTIMENTO USAF	USAF PROVISION		
9110	SENZA CILINDRI SOLLEVAMENTO	LIFT CYLINDERS DEDUCTION	SANS CYLINDRES SOULEVEMENT	OHNE HUBZYLINDER
9113	SENZA TUBAZ E CILINDRI SOLLEV	LIFT CYLINDERS & PIPING DEDUCT	SANS TUYAUT. ET SYL. SOUL.	OHNE LEITUNGEN UND HUBZYLINDER
9115	BLOCCAGGIO ARTICOLAZ BRACCI	BJOM LINKAGE LOCK	BLOCCAGE ARTICULATION BRAS	HUBGESTAENGEARRETTERUNG
9116	ALLESTIMENTO FAMA	FAMA PROVISION		
9117	PREPARAZIONE P/SPEDIZIONE	SHIPPING PREPARATION		
9130	SENZA DISPOSITIVO EQUISTATIC	EQUISTATIC DEVICE DEDUCTION	SANS DISPOSITIF EQUISTATIQUE	OHNE EQUISTATIK
9159	SENZA VERNICIATURA A SMALTO			
9200	SENZA BOZZELLI GANCIO	HOOK SHEAVES DEDUCTION	SANS MOUFLE DE CROCHET	OHNE HAKENSEILBLOCK
9206	SPECIAL CONTRACT	SPECIAL CONTRACT		
9220	SENZA ZAVORRE POSTERIORI	REAR COUNTERWEIGHT DEDUCTION	SANS LESTS ARRIERES	OHNE KONTERGEWICHT HINTER
9225	SENZA COMANDO FREE FALL	FREE FALL CONTROL DEDUCTION	SANS COMMANDE FREE FALL	OHNE FREIFALL-EINRICHTUNG
9230	SENZA ZAVORRA E SOPPORTO (ANT)		SANS LEST ET SUPP (AV)	OHNE KONTERGEWICHT/KONSOLE VOR
9232	SENZA ZAVORRE LATERALI	SIDE COUNTERWEIGHT DEDUCTION	SANS LESTS LATERAUX	OHNE SEITLICHES KONTERGEWICHT
9242	SENZA PNEUMATICI	TIRE OMISSION	SANS PNEUS	OHNE REIFEN
9491	SENZA PNEUMATICI E CERCHI	TIRE AND WHEEL OMISSION	SANS PNEUS ET CEIGLES	OHNE REIFEN UND FELGEN
9506	SENZA SUOLE	SHOES DEDUCTION	SANS PATINS	OHNE KETTENPLATTEN
9512	SENZA CATENARIA E SUOLE	TRACK CHAIN & SHOES DEDUCTION	SANS CHENILLE ET PATINS	OHNE KETTENZUG UND PLATTEN
9580	SENZA CABINA	CAB OMISSION		
9672	SENZA RISCALDATORE	HEATER DEDUCTION	SANS CHAUFFAGE	OHNE HEIZUNG
9733	SENZA EMERGENCY STEERING	EMERGENCY STEERING DEDUCTION	SANS DIRECTION D'EMERGENCE	OHNE NOTLENKUNG
9764	FORNITURE ESTERNE	PURCHASED FINISH (P.F.)		
9765	COMANDI MOTORE (PF MOTORE)	ENGINE CONTROLS (ENGINE PF)		MOTORSTEUERUNG
9761	SENZA BACK UP ALARM	BACK UP ALARM DEDUCTION	SANS BACK UP ALARM	OHNE RUECKFAHRTWARANLAGE
9860	TARGHE E MANUALI	MANUALS AND DECALS	PLAQUES ET MANUELS	KLEINESCHILDER UND HANDBUECHER
9861	TARGHE D'IDENTIFICAZIONE	IDENTIFICATION PLATES	PLAQUE D'IDENTIFICATION	TYPLENSCHILDER
9862	MARCHI DELLA DITTA	TRADE MARKS		FIRMENZEICHEN
9868	SENZA RIBALTAMENTO SEDILE			
9850	SENZA SEDILE	SEAT DEDUCTION	SANS SIEGE	OHNE SITZ
9851	SENZA SEDILE E SOPPORTO	SEAT AND PEDESTAL DEDUCTION	SANS SIEGE ET SUPPORT	OHNE SITZ UND KONSOLE
9876	SENZA STRUTTORI PROTEZIONE	ROPS CANOPY DEDUCTION	SANS STRUCTURE DE PROTECTION	OHNE SCHUTZBÄNNE
9890	SENZA BARRA DI TRAINO	SWINGING DRAWBAR DEDUCTION	SANS BARRE D'ATTELAGE	OHNE ZUGPENDEL
9891	SENZA GANCIO TRAINO	DRAWBAR DEDUCTION	SANS CROCHET D'ATTALAGE	OHNE ZUGHAKEN
9960	OLIAZIONI FINALI	FINAL PREPARATION		
9968	LUBRIFICANTI	LUBRICANTS	LUBRIFIANTS	
				SIN ESTRUCTURA DE PROTECCION

E

AUXILIARY ATTACHMENT AND EQUIPMENT • ORGANI SUSSIDIARI (E ATTREZZI) • ORGANES AUXILIAIRES (ET EQUIPEMENT)
N. BENIGORRI (E) (UND GERÄTE) • GRUPOS AUXILIARES (Y EQUIPO)

Q1

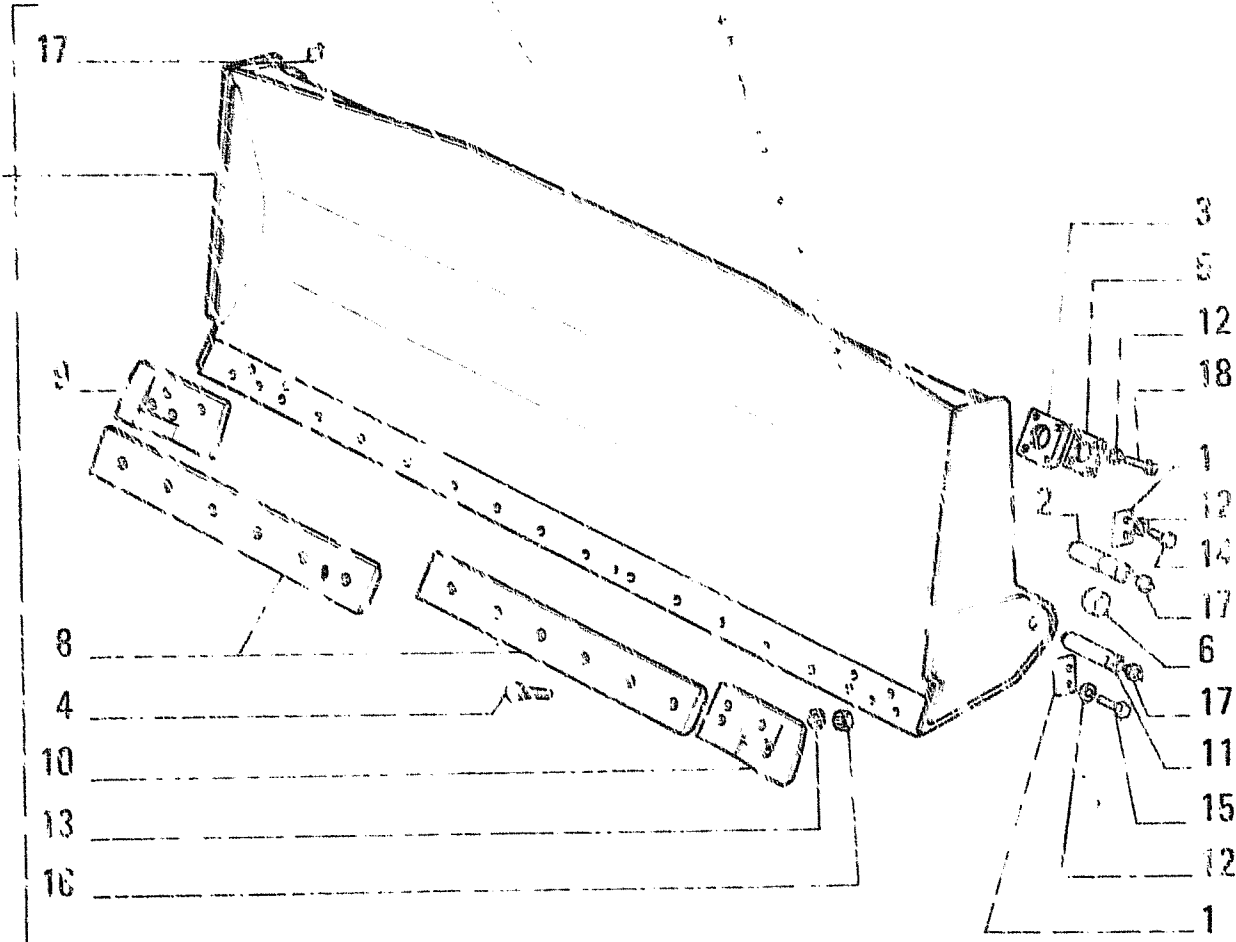

OPTIONAL
VARIANTE 30.0405.02.1

ITEM	PART NUMBER	TRANS CODE	DESCRIPTION	DESCRIZIONE
13	0517371	24	10D NUT 18,2x4,2 D2936	DADO 18,2x4,2 D2936
14	11115331	2	40V SCREW 14x2x90	VITE 14x2x90
15	11400991	4	40V SCREW 14x1,5x35	VITE 14x1,5x35
16	11703227	24	10D NUT 16x2,5x15 D2936	DADO 16x2,5x15 D2936
	12163327	22	10D NUT 16x2x13 C2936	DADO 16x2x13 C2936
17	13407211	6	60I GREASE FITTING 10x1	INGRASSATORE 10x1
18	15977931	8	40V SCREW 14x1,5x90	VITE 14x1,5x90

DOZER BLADE — LAMA APRIPISTA — LAME DOZER — PLAVIER SCHILD — PALETA ABRETROCHAS

E3.13/5

N.T.R. 191 - 20.02.1990

604.01.081.04

Q2

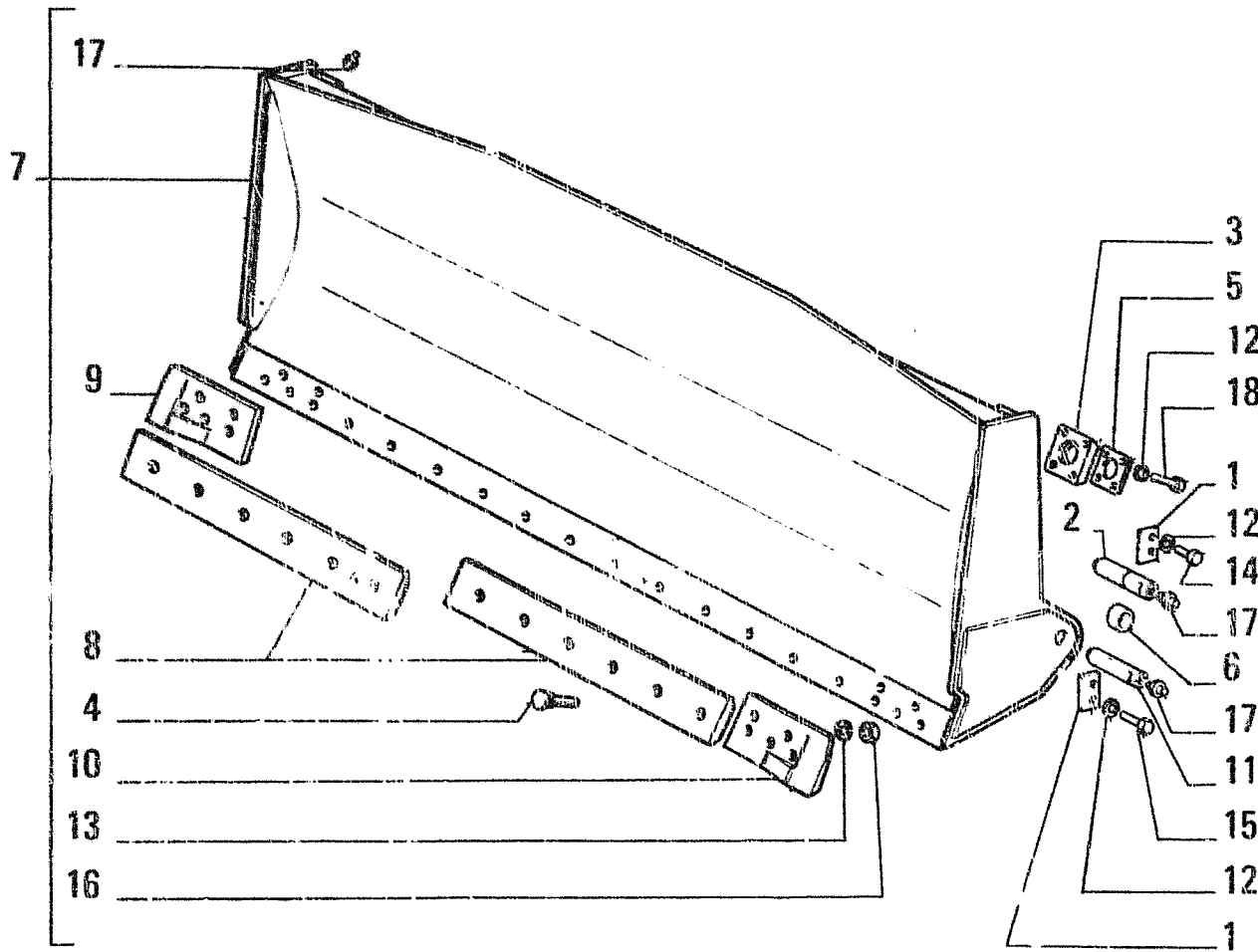

OPTIONAL
VARIANTE 30.0405.02.1

ITEM	PART NUMBER	QTY	TRANS CODE	DESCRIPTION	DESCRIZIONE
1	8270126	4	110P	PLAQUE	PIASTRINA
2	8280936	2	80P	PIN	PERNO
3	8283053	2	75S	BALL SOCKET	SEDE SFERICA
4	8283258	22	40V	SCREW C2936	VITE C2936
	8299688	24	40V	SCREW D2936	VITE D2936
5	8283325		1983	SHIM	SPESSORE
6	8283916	4	75D	SPACER	DISTANZIALE
7	8296152	1	12L	DOZER MOLDBOARD - ASSEMBLY C2936	LAMA BULLDOZER - COMPLETO C2936
	79041160	1	12L	DOZER MOLDBOARD - ASSEMBLY D2936	LAMA BULLDOZER - COMPLETO D2936
8	8296167	2	18T	CUTTING EDGE CENTR. C2936	TAGLIENTE CENTR. C2936
	76001392	2	18T	CUTTING EDGE CENTR. D2936	TAGLIENTE CENTR. D2936
9	8296169	1	18T	CUTTING EDGE - SIDE RIGHT C2936	TAGLIENTE - LATERALE DESTRO C2936
	76001393	1	18T	CUTTING EDGE - SIDE RIGHT D2936	TAGLIENTE - LATERALE DESTRO D2936
10	8296170	1	18T	CUTTING EDGE - SIDE LEFT C2936	TAGLIENTE - LATERALE SINISTRO C2936
	76001394	1	18T	CUTTING EDGE - SIDE D2936	TAGLIENTE - LATERALE D2936
11	8296177	2	80P	PIN	PERNO
12	10517171	14	132R	LOCKWASHER 14,2x3,5	ROSETTA DI SICUREZZA 14,2x3,5
13	10517271	22	132R	LOCKWASHER 16,2x4 C2936	ROSETTA DI SICUREZZA 16,2x4 C2936

DOZER BLADE - LAMA APRIPISTA - LAME DOZER PLANIER SCHILD PALETA ABRETROCHAS

E3.13/5

N.T.R 191 - 20.02.1990

604.01.081.04

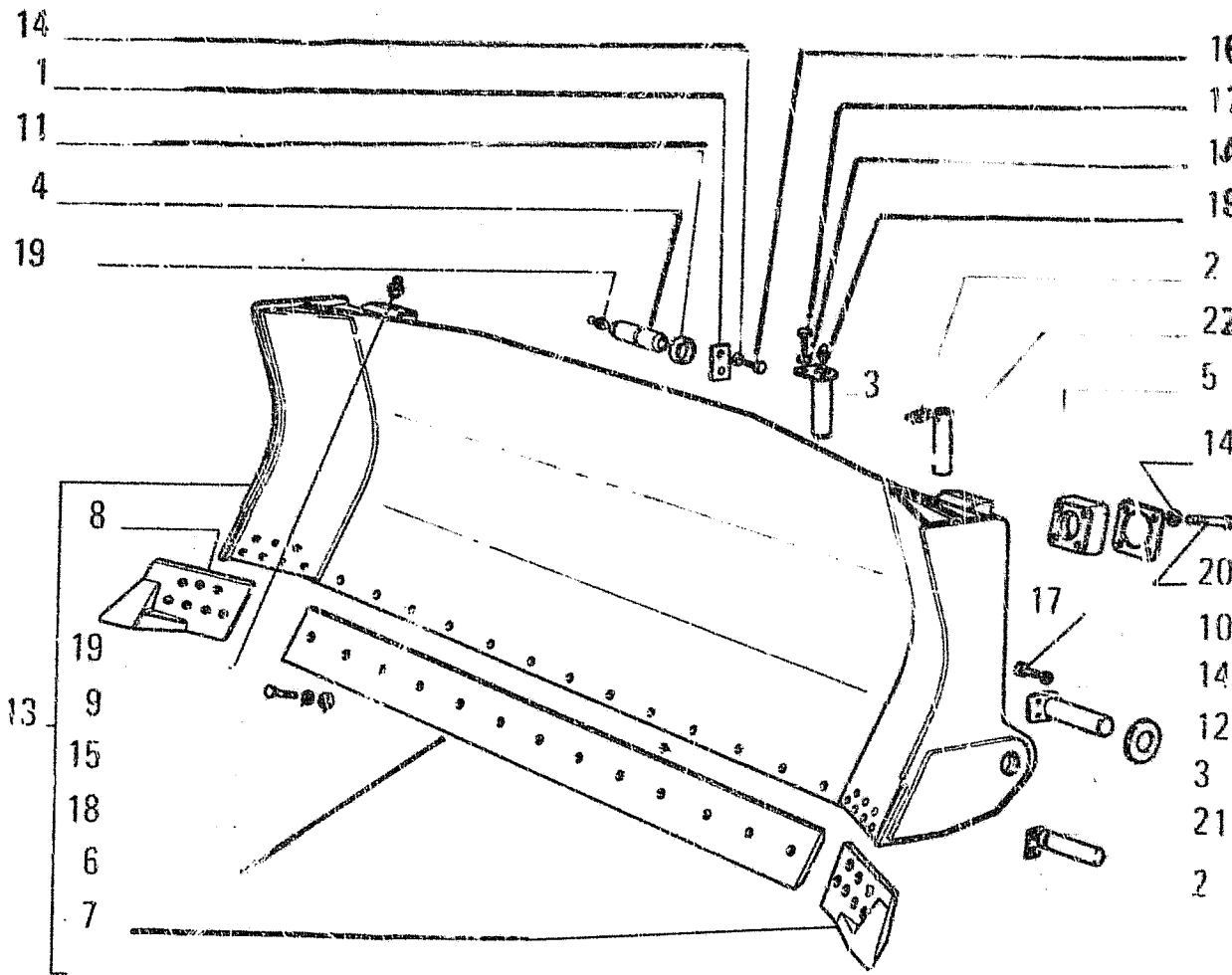

OPTIONAL
VARIANTE 30.0405.03.1

ITEM	PART NUMBER	QTY	TRANS CODE	DESCRIPTION	DESCRIZIONE
15	10517271	27	132R	LOCKWASHER 16,2x4 C2936	ROSETTA DI SICUREZZA 16,2x4 C2936
2	10517371	25	132R	LOCKWASHER 18,2x4,2 D2936	ROSETTA DI SICUREZZA 18,2x4,2 D2936
22	16 11115531	4	40V	SCREW 14x2x30	VITE 14x2x30
17	11115531	8	40V	SCREW 14x2x30 D2936	VITE 14x2x30 D2936
5	11408331	8	40V	SCREW 14x1,5x35 C2936	VITE 14x1,5x35 C2936
18	11703227	25	10D	NUT 18x2,5x15 D2936	DADO 18x2,5x15 D2936
14	12163327	27	10D	NUT 16x2x13 C2936	DADO 16x2x13 C2936
19	13407211	6	60I	GREASE FITTING 10x1	INGRASSATORE 10x1
20	15977931	8	40V	SCREW 14x1,5x90	VITE 14x1,5x90
21	76000809	2	80P	PIN D2936	PERNO D2936
22	76000811	2	80P	PIN D2936	PERNO D2936

DOZER BLADE - LAMA APRIPISTA - LAME DOZER - PLANIER SCHILD - PALETA ABRETROCHAS

E3.13 4

N.T.R. 191 - 20.02.1990

604.01.081.04

Q4

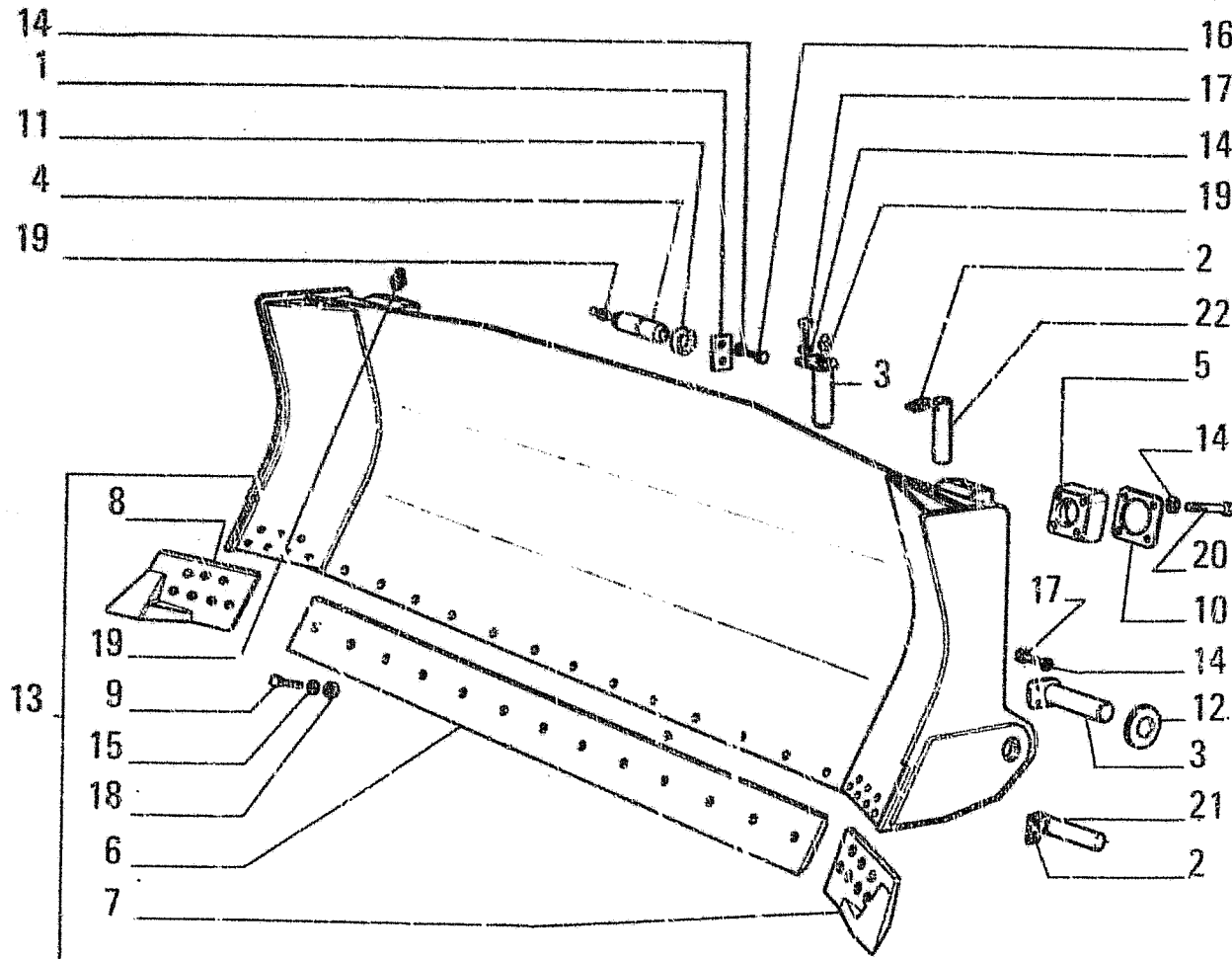

OPTIONAL
VARIANTE 30.0405.03.1

ITEM	PART NUMBER	QTY	TRANS CODE	DESCRIPTION	DESCRIZIONE
1	8270126	2	110P	PLAQUE	PIASTRINA
2	8270126	4	110P	PLAQUE D2936	PIASTRINA D2936
3	8280389	4	80P	PIN C2936	PERNO C2936
4	8280936	2	80P	PIN	PERNO
5	8283053	2	75S	BALL SOCKET	SEDE SFERICA
6	8283232	1	18T	CUTTING EDGE CENTR. C2936	TAGLIANTE CENTR. C2936
7	8299623	1	18T	CUTTING EDGE CENTR. D2936	TAGLIANTE CENTR. D2936
8	8283233	1	18T	CUTTING EDGE LAT.S. C2936	TAGLIANTE LAT.S. C2936
9	8299625	1	18T	CUTTING EDGE - SIDE D2936	TAGLIANTE - LATERALE D2936
10	8283234	1	18T	CUTTING EDGE - SIDE C2936	TAGLIANTE - LATERALE C2936
11	8299624	1	18T	CUTTING EDGE - SIDE D2936	TAGLIANTE - LATERALE D2936
12	8283258	27	40V	SCREW C2936	VITE C2936
13	8299688	25	40V	SCREW D2936	VITE D2936
14	8283325		190S	SHIM	SPESSORE
15	8283916	4	75D	SPACER	DISTANZIALE
16	8285653	2	75D	SPACER	DISTANZIALE
17	8297427	1	12L	DOZER MOLDBOARD - ASSEMBLY C2936	LAMA BULLDOZER - COMPLETO C2936
18	76013747	1	12L	DOZER MOLDBOARD - ASSEMBLY D2936	LAMA BULLDOZER - COMPLETO D2936
19	10517171	20	132R	LOCKWASHER 14,2x3,5	ROSETTA DI SICUREZZA 14,2x3,5

DOZER BLADE - LAMA APRIPISTA - LAME DOZER - PLANIER SCHILD - PALETA ABRETROCHAS

E3.13/4

N.T.R. 191 - 20.02.1990

604.01.081.04

Q5

TRA

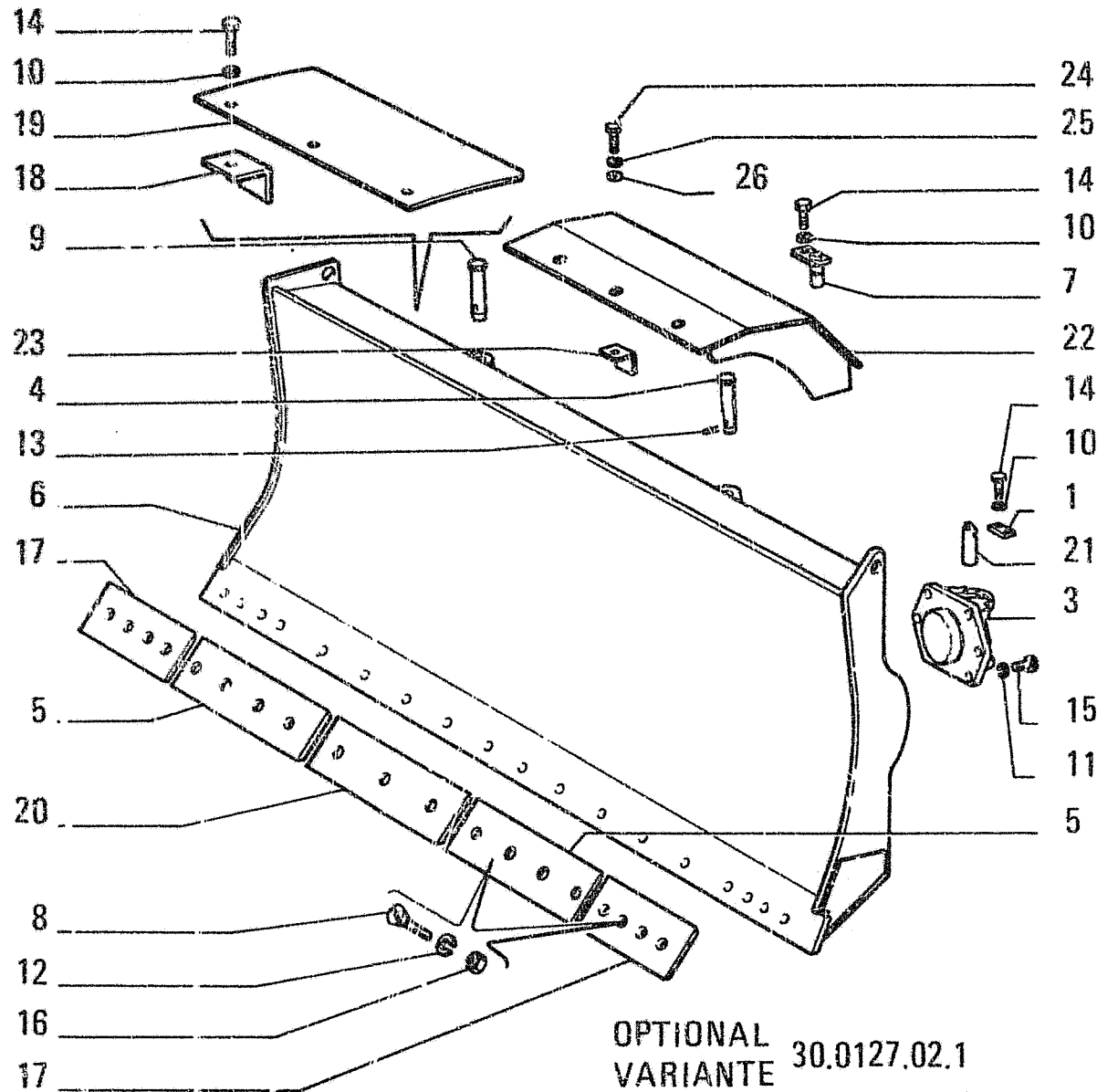

ITEM	PART NUMBER	QTY	TRANS CODE	DESCRIPTION	DESCRIZIONE
24	1111031	3	40V	SCREW 14x2x35 D3279	VITE 14x2x35 D3279
25	1051179	3	170R	LOCKWASHER 14,2x3,5 D3279	ROSETTA EL. 14,2x3,5 D3279
26	1052121	3	131R	WASHER 14,4x26 D3279	ROSETTA 14,4x26 D3279

DOZER BLADE – LAMA APRIPISTA – LAME DOZER – PLANIER SCHI.D – PALETA ABRETROCHAS

E3.13/3

N.T.R. 200 - 15.10.1990

604.01.081.05

Q6

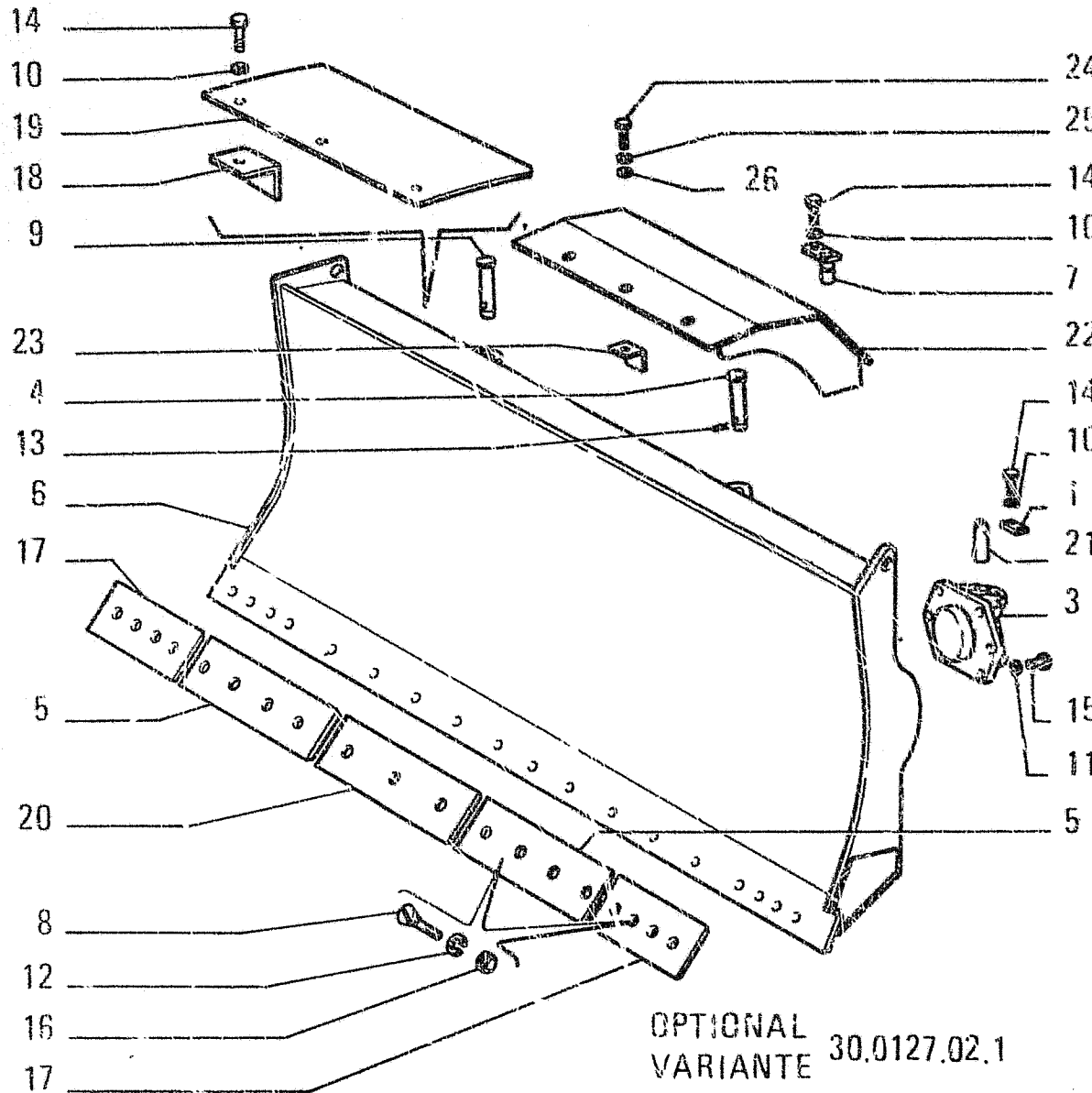

ITEM	PART NUMBER	QTY	TRANS CODE	DESCRIPTION	DESCRIZIONE
1	8297638	1	110P	PLAQUE	PIASTRINA
3	8297721	1	300S	SUPPORT C1620	SUPPORTO C1620
	79078988	1	300S	SUPPORT D1620	SUPPORTO D1620
4	8298387	1	80P	PIN - LEFT	PERNO - SINISTRO
5	8298398	2	18T	CUTTING EDGE	TAGLIENTE
6	8298403	1	10L	MOLDBOARD - ASSEMBLY	LAMA - COMPLETO
7	8298412	2	80P	PIN	PERNO
8	8298583	19	40V	SCREW	VITE
9	8298593	1	80P	PIN - RIGHT	PERNO - DESTRO
10	10516871	4	132R	LOCKWASHER 10x2,5	ROSETTA DI SICUREZZA 10x2,5
		3	132R	LOCKWASHER 10x2,5 C3279	ROSETTA DI SICUREZZA 10x2,5 C3279
11	10517171	6	132R	LOCKWASHER 14,2x3,5	ROSETTA DI SICUREZZA 14,2x3,5
12	10517371	19	132R	LOCKWASHER 18,2x4,2	ROSETTA DI SICUREZZA 18,2x4,2
13	10733901	2	270C	COTTER PIN 3,5x57	COPIGLIA 3,5x57
14	11106231	4	40V	SCREW 10x1,5x25	VITE 10x1,5x25
		3	40V	SCREW 10x1,5x25 C3279	VITE 10x1,5x25 C3279
15	11115831	6	40V	SCREW 14x2x40	VITE 14x2x40
16	11703227	19	10D	NUT 18x2,5x15	DADO 18x2,5x15
17	79025223	2	18T	CUTTING EDGE - SIDE	TAGLIENTE - LATERALE
18	79026740	3	225S	BRACKET C3279	STAFFA C3279
19	79026742	1	70R	GUARD C3279	RIPARO C3279
20	79033808	1	18T	CUTTING EDGE CENTR.	TAGLIENTE CENTR.
21	79048237	1	80P	PIN C1620	PERNO C1620
	79078991	1	80P	PIN D1620	PERNO D1620
22	76017329	1	70R	GUARD D3279	RIPARO D3279
23	76017693	3	225S	BRACKET D3279	STAFFA D3279

DOZER BLADE - LAME APRIPISTA - LAME DOZER - PLANIER SCHILD - PALETA ABRETROCHAS

E3.13/3

N.T.R. 200 - 15.10.1990

C94.01.081.05

Q7

PARTS MARKED * ARE NOT SUPPLIED AS SPARES
 I PARTICOLARI CONTRASSEGNA TI CON * NON
 VENGONO FORNITI D. RICAMBIO

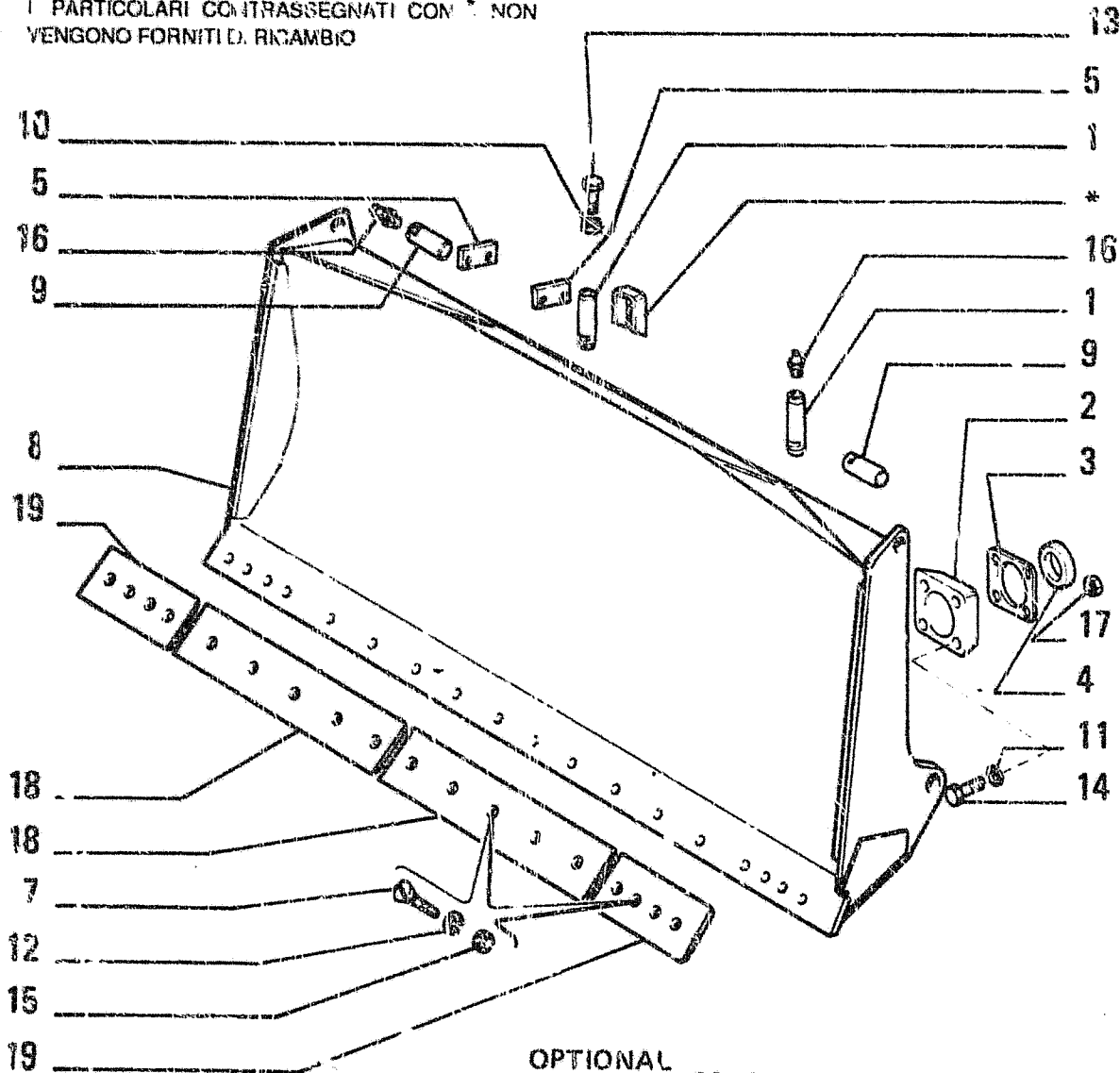

OPTIONAL
 VARIANTE 30.1056.04.1

FIATALLIS FD7

ITEM	PART NUMBER	QTY	TRANS CODE	DESCRIPTION	DESCRIZIONE
1	8280936	2	80P	PIN	PERNO
2	8283053	4	64C	CAP	CAPPELLO
3	8283325	8	197S	PAD	SPESSORE ELASTICO
4	8283916	4	75D	SPACER	DISTANZIALI
5	8289428	4	110P	PLAQUE	PUNTERIA
6	*	1	225S	BRACKET	STATI FA
7	8298583	18	40V	SCREW	VITE
8	8298727	1	10L	MOLDBOARD - ASSEMBLY	LAMA - COMPLETO
9	8298745	2	80P	PIN	PERNO
10	10517071	8	132R	LOCKWASHER 12,2x3,1	ROSETTA DI SICUREZZA 12,2x3,1
11	10517171	16	132R	LOCKWASHER 14,2x3,5	ROSETTA DI SICUREZZA 14,2x3,5
12	10517371	18	132R	LOCKWASHER 18,2x4,2	ROSETTA DI SICUREZZA 18,2x4,2
13	11112231	8	40V	SCREW 12x1,75x22	VITE 12x1,75x22
14	11117031	16	40V	SCREW 14x2x90	VITE 14x2x90
15	11703227	18	10D	NUT 18x2,5x15	DADO 18x2,5x15
16	13407211	4	60H	GREASE FITTING 10x1	INGRASSATORE 10x1
17	14073910	2	10D	NUT 12x1,75x19	DADO 12x1,75x19
18	79025222	2	18T	CUTTING EDGE	TAGLIENTE
19	79025223	2	18T	CUTTING EDGE - SIDE	TAGLIENTE - LATERALE

DOZER BLADE - LAMA APRIPISTA - LAME DOZER - PLANIERSCHILD - PALETA ABRETROCHAS

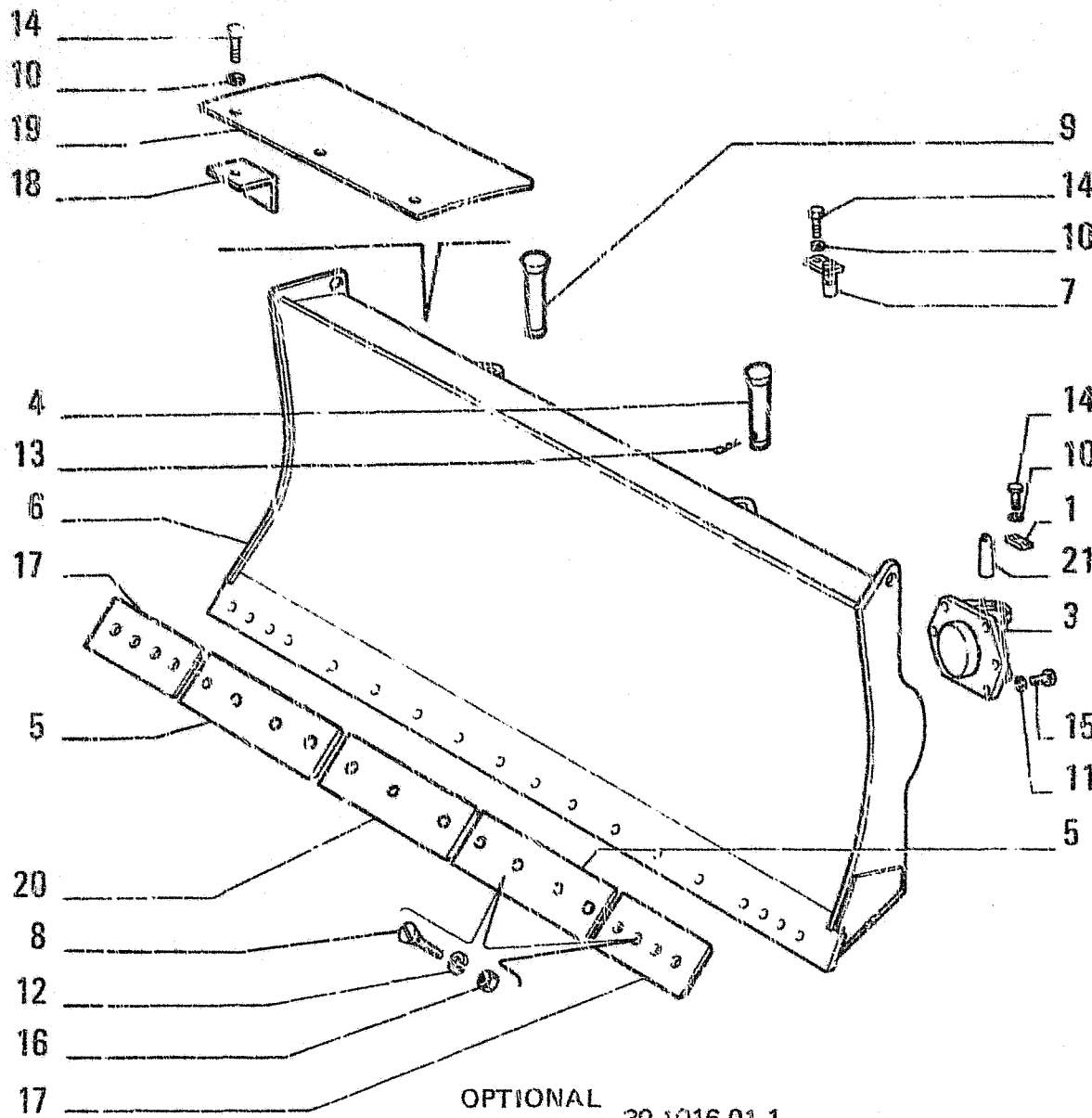

ITEM	PART NUMBER	QTY	TRANS CODE	DESCRIPTION	DESCRIZIONE
1	8297638	1	110P	PLAQUE	PIASTRINA
2	8297712	4	75D	SPACEW EL.	DISTANZIALE EL.
3	8297721	1	300S	SUPPORT	SUPPORTO
4	8298387	1	80P	PIN - LEFT	PERNO - SINISTRO
5	8298398	2	18T	CUTTING EDGE	TAGLIANTE
6	8298403	1	10L	MOLDBOARD - ASSEMBLY	LAMA - COMPLETO
7	8298412	2	80P	PIN	PERNO
8	8298583	19	40V	SCREW	VITE
9	8298593	1	80P	PIN - RIGHT	PERNO - DESTRO
10	10516871	7	132R	LOCKWASHER 10x2,5	ROSETTA DI SICUREZZA 10x2,5
11	10517171	6	132R	LOCKWASHER 14,2x3,5	ROSETTA DI SICUREZZA 14,2x3,5
12	10517371	19	132R	LOCKWASHER 10,2x4,2	ROSETTA DI SICUREZZA 10,2x4,2
13	10733901	2	270C	COTTER PIN 3,5x57	CCPIGLIA 3,5x57
14	11106231	7	40V	SCREW 10x1,5x25	VITE 10x1,5x25
15	11115831	6	40V	SCREW 14x2x40	VITE 14x2,40
16	11703227	19	10D	NUT 18x2,5x15	DADO 18x2,5x15
17	79025223	2	18T	CUTTING EDGE - SIDE	TAGLIANTE - LATERALE
18	79026740	3	225S	BRACKET	STAFFA
19	79026742	1	70R	GUARD	FIPARO
20	79033808	1	18T	CUTTING EDGE CENTR.	TAGLIANTE CENTR.
21	79048237	1	80P	PIN	PERNO

DOZER BLADE - LAMA APRIPISTA - LAME DOZER - PLANIER SCHILD - PALETA ABRETROCHAS

ES.13/1

N.T.R. 191 - 20.02.1990

604.01.081.04

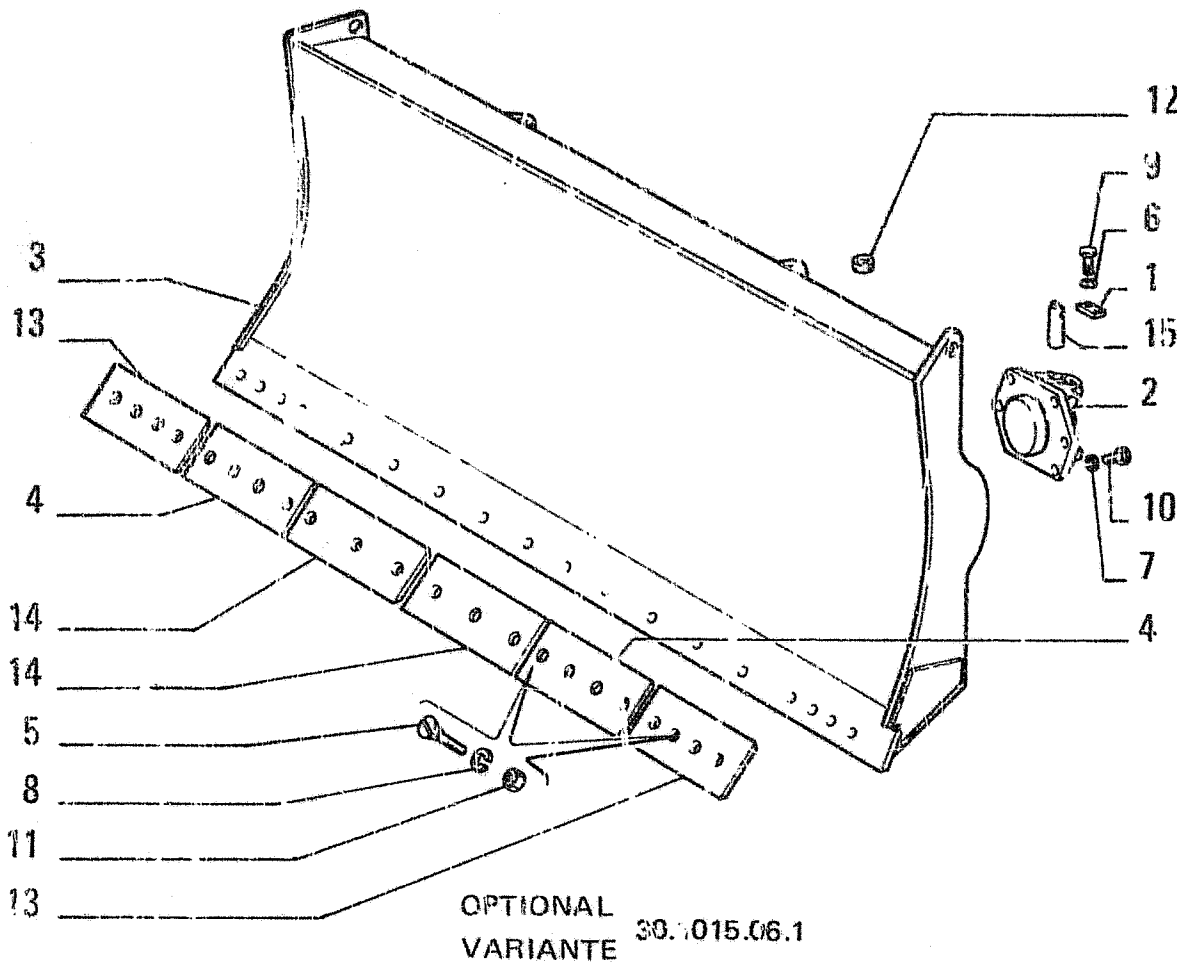

ITEM	PART NUMBER	QTY	TRANS CODE	DESCRIPTION	DESCRIZIONE
1	8297638	1	110P	PLAQUE	PIASTRINA
2	8297721	1	300S	SUPPORT	SUPPORTO
3	8298482	1	10L	MOLDBOARD - ASSEMBLY	LAMA - COMPLETO
4	8298497	2	18T	CUTTING EDGE	TAGLIENTE
5	8298583	22	40V	SCREW	VITE
6	10516871	2	132R	LOCKWASHER 10x2,5	ROSETTA DI SICUREZZA 10x2,5
7	10517171	6	132R	LOCKWASHER 14,2x3,5	ROSETTA DI SICUREZZA 14,2x3,5
8	10517371	22	132R	LOCKWASHER 18,2x4,2	ROSETTA DI SICUREZZA 18,2x4,2
9	11106231	2	40V	SCREW 10x1,5x25	VITE 10x1,5x25
10	11115831	6	40V	SCREW 14x2x40	VITE 14x2x40
11	11703227	22	10D	NUT 18x2,5x15	DADO 18x2,5x15
12	14073910	1	10D	NUT 12x1,75x19	DADO 12x1,75x19
13	79025223	2	18T	CUTTING EDGE - SIDE	TAGLIENTE - LATERALE
14	79033806	2	18T	CUTTING EDGE CENTR.	TAGLIENTE CENTR.
15	79048237	1	80P	PIN	PERNO

DOZER BLADE - LAMA APPIPISTA - LAME DOZER - PLANIER SCHILD - PALETA ABRETROCHAS

E3.13

Q10

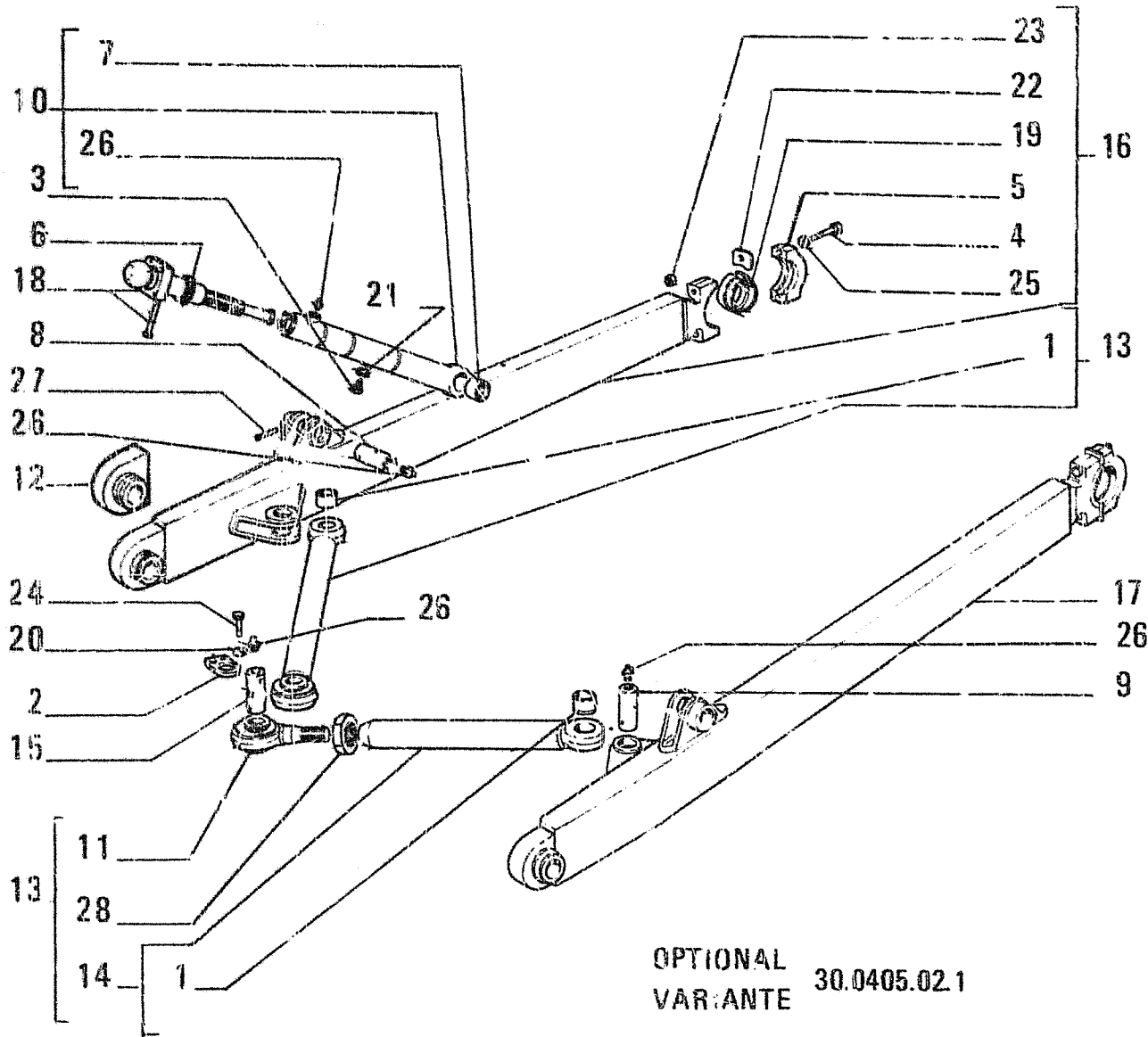

ITEM	PART NUMBER	QTY	TRANS CODE	DESCRIPTION	DESCRIZIONE
17	8296564	1	170B	BOOM - ASSEMBLY	BRACCIO - COMPLETO
18	8296574	1	141T	THREADED TIEROD	TIRANTE FILETTATO
19	8280721	1	96S	HALF BUSHING	SEMIBOCCOLA
20	10517171	4	132R	LOCKWASHER 14,2x3,5	ROSETTA DI SICUREZZA 14,2x3,5
21	10517271	1	132R	LOCKWASHER 16,2x4	ROSETTA DI SICUREZZA 16,2x4
22	8280723	2	110P	PLAQUE	PIASTRINA
23	12163527	2	10D	NUT 20x2,5x16	DADO 20x2,5x16
24	11400331	4	40V	SCREW 14x1,5x35	VITI: 14x1,5x35
25	10517471	2	132R	LOCKWASHER 20,2x4,5	ROSETTA DI SICUREZZA 20,2x4,5
26	13407211	8	60I	GREASE FITTING 10x1	1/4GRASSATORE 10x1
27	14173570	4	200S	PIN 10,5x80	SPINA 10,5x80
28	79024479	1	50G	RING NUT D2936	GHIERA D2936

OPTIONAL
VARIANTE 30.0405.02.1

DOZER BLADE LIFTING ARMS - BRACCI SOLLEVAMENTO APRIPISTA - BRAS DE LEVAGE DE LAME
DOZER - HUBARME FUER LADESCHAUFEL - BRAZOS DE ELEVACION DE LA PALA

E3.10/9

N.T.R. 205 - 30.09.1991
604.01.081.06

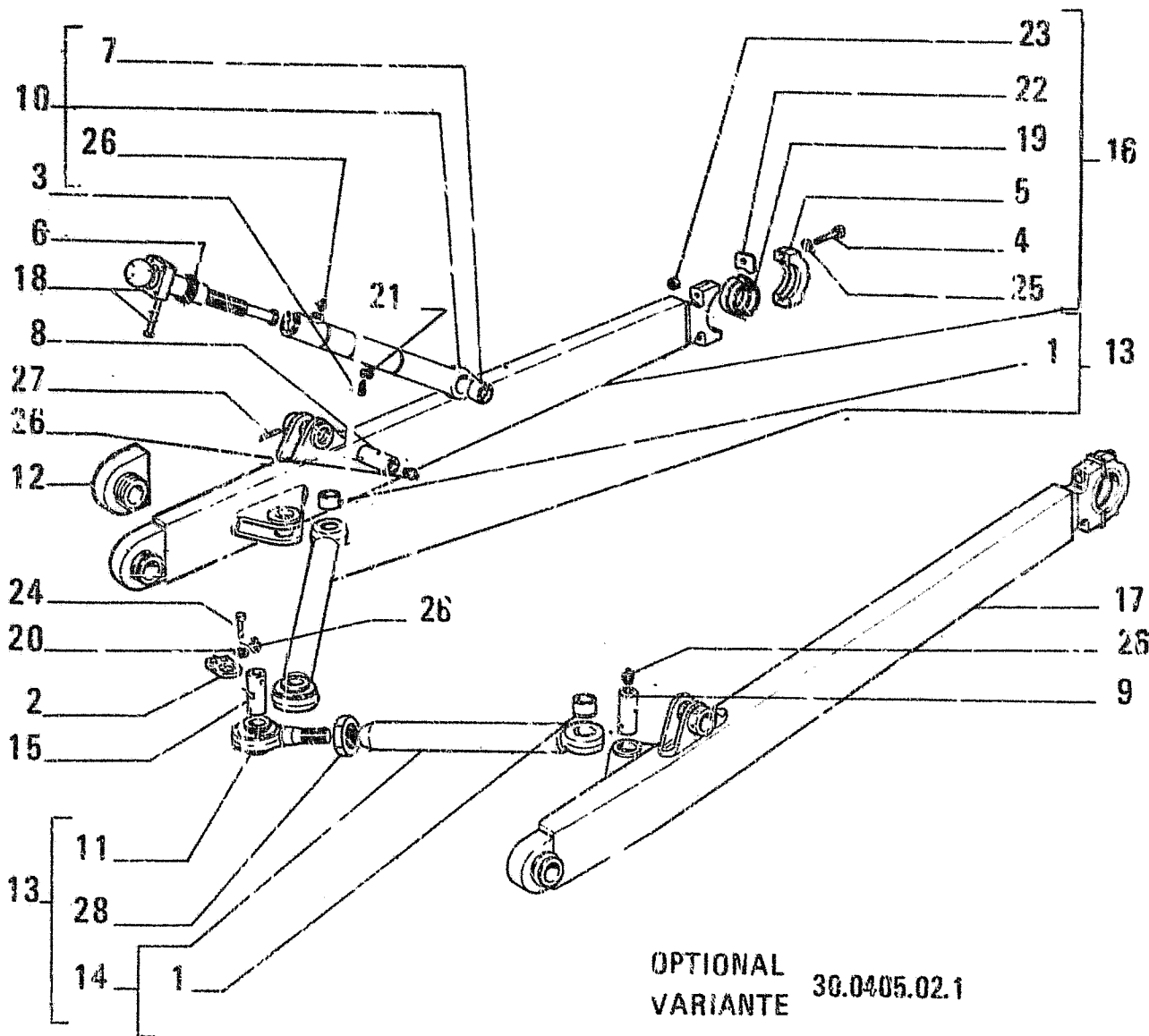

ITEM	PART NUMBER	QTY	TRANS CODE	DESCRIPTION	DESCRIZIONE
1	8270124	1	95B	BUSHING - REAR	BOCCOLA - POSTERIORE
2	8270126	2	110P	PLAQUE	PIASTRINA
3	8290332	1	40V	SCREW	VITE
4	11090037	2	40V	SCREW 20x2,5x185	VITE 20x2,5x185
5	8296713	1	300S	SUPPORT	SUPPORTO
6	8281853	1	42A	MUDSCRAPER RING	ANELLO RASCHIAFANGO
7	8283007	1	95B	BUSHING	BOCCOLA
8	8285654	2	80P	PIN	PERNO
9	8285655	2	80P	PIN	PERNO
10	8285707	1	141T	THREADED TIEROD - SIDE ASSEMBLY	TIRANTE FILETTATO - LATERALE COMPLETO
11	8287899	1	141T	THREADED TIEROD - FRONT C2936	TIRANTE FILETTATO - ANTERIORE C2936
	76000804	2	141T	THREADED TIEROD - FRONT D2936	TIRANTE FILETTATO - ANTERIORE D2936
12	8288219	2	300S	SUPPORT - FRONT TO BE WELDED	SUPPORTO - ANTERIORE DA SALDARE
13	8292408	2	141T	THREADED TIEROD - ASSEMBLY C2936	TIRANTE FILETTATO - COMPLETO C2936
	76001854	2	141T	THREADED TIEROD - ASSEMBLY D2936	TIRANTE FILETTATO - COMPLETO D2936
14	8292410	2	141T	THREADED TIEROD - ASSEMBLY C2936	TIRANTE FILETTATO - COMPLETO C2936
	76001856	2	141T	THREADED TIEROD - ASSEMBLY D2936	TIRANTE FILETTATO - COMPLETO D2936
15	8296177	2	80P	PIN	PERNO
16	8296563	1	130B	BOOM - ASSEMBLY	BRACCIO - COMPLETO

DOZER BLADE LIFTING ARMS - BRACCI SOLLEVAMENTO APRIPISTA - BRAS DE LEVAGE DE LAME
 DOZER - HUBARME FUHR LADESCHAUFEL - BRAZOS DE ELEVACION DE LA PALA

E3.10/9

N.T.R. 205 - 30.09.1991
 604.01.081.06

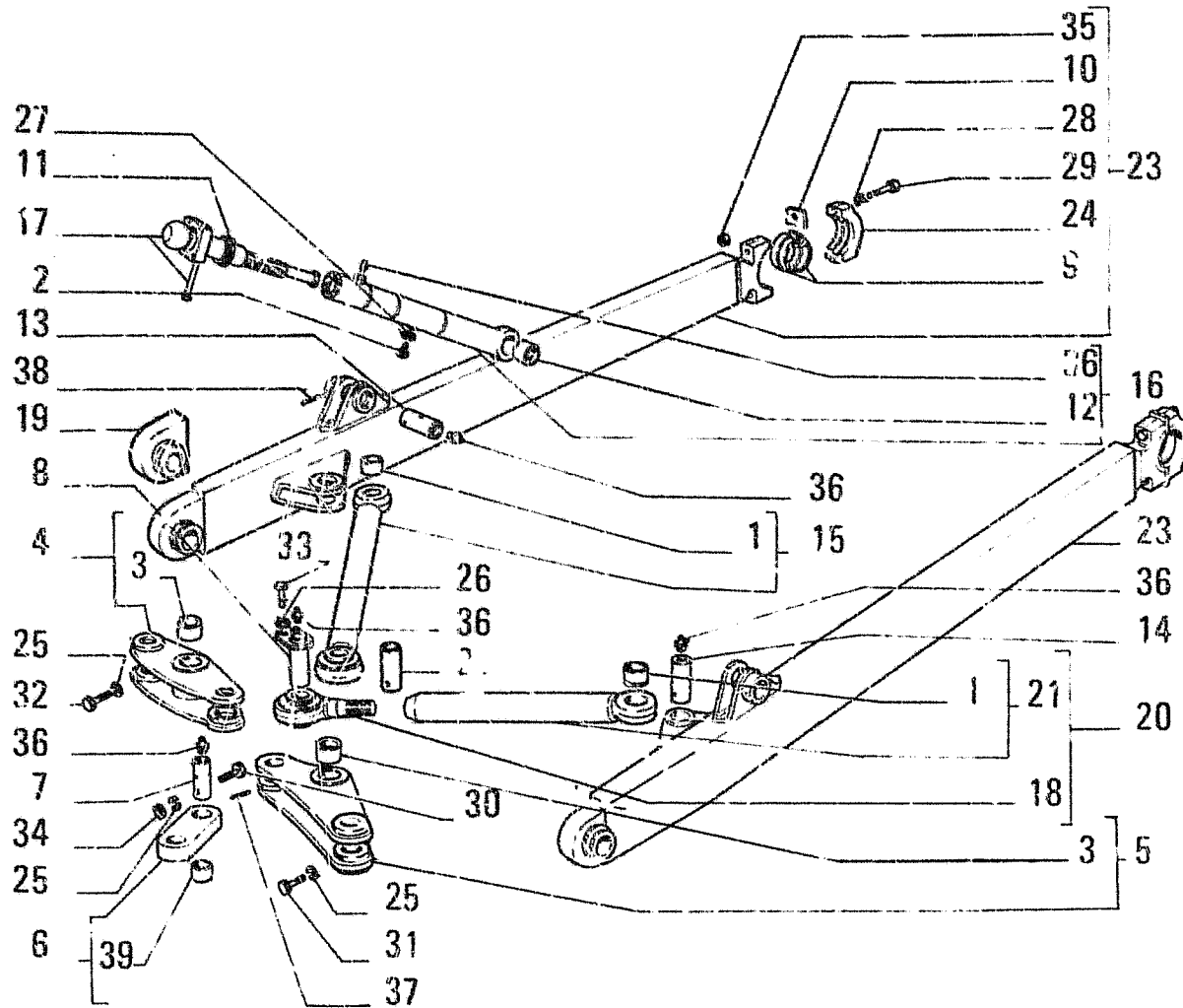

OPTIONAL
VARIANTE 30.0405.03.1

ITEM	PART NUMBER	QTY	TRANS CODE	DESCRIPTION	DESCRIZIONE
38	14173570	4	200S	PIN 10,5x80	PINA 10,5x80
39	8280391	2	95B	BUSHING	BOCCOLA

DOZER BLADE LIFTING ARMS - BRACCI SOLLEVAMENTO APRUPISIA - BRAS DE LEVAGE DE LAME
DOZER - HUBARME FUER LADESCHAUFEL - BRAZOS DE ELEVACION DE LA PALA

E3.10/8

N.T.R. 205 - 30.09.1991
604.01.081.06

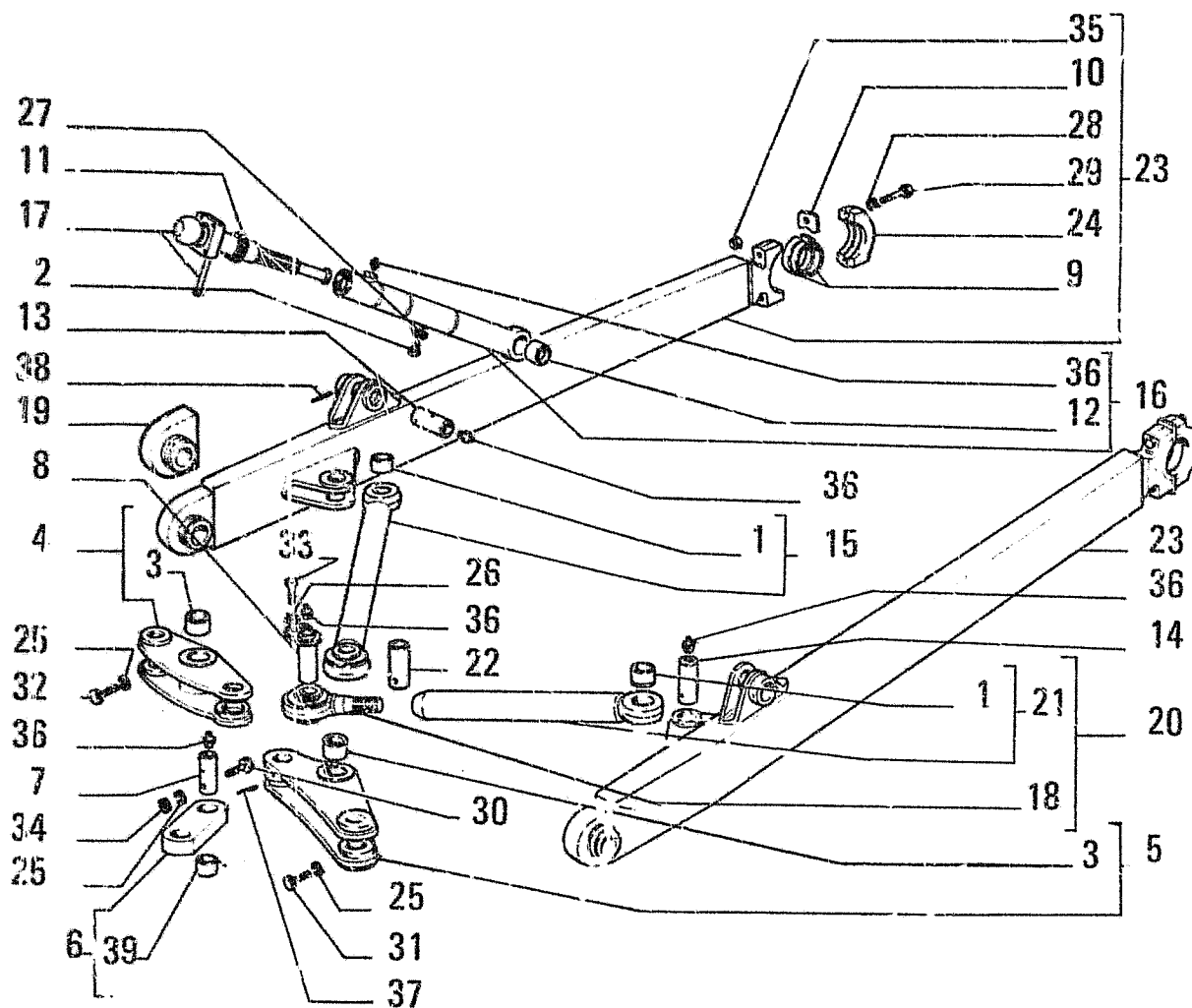

OPTIONAL
VARIANTE 30.0405.03.1

ITEM	PART NUMBER	QTY	TRANS CODE	DESCRIPTION	DESCRIZIONE
20	8292408	1	141T	THREADED TIEROD - ASSEMBLY C2936	TIRANTE FILETTATO - COMPLETO C2936
	76001854	1	141T	THREADED TIEROD - ASSEMBLY D2936	TIRANTE FILETTATO - COMPLETO D2936
21	8292410	1	141T	THREADED TIEROD - ASSEMBLY C2936	TIRANTE FILETTATO - COMPLETO C2936
	76001856	1	141T	THREADED TIEROD - ASSEMBLY D2936	TIRANTE FILETTATO - COMPLETO D2936
22	8295647	2	80P	PIN D2936	PERNO D2936
23	8296563	1	130B	BOOM - ASSEMBLY	BRACCIO - COMPLETO
	8296564	1	130B	BOOM - ASSEMBLY	BRACCIO - COMPLETO
24	8296713	1	300S	SUPPORT	SUPPORTO
25	10517071	4	132R	LOCKWASHER 12,2x3,1 D2936	ROSETTA DI SICUREZZA 12,2x3,1 D2936
26	10517171	4	132R	LOCKWASHER 14,2x3,5 C2936	ROSETTA DI SICUREZZA 14,2x3,5 C2936
27	10517271	1	132R	LOCKWASHER 16,2x4	ROSETTA DI SICUREZZA 16,2x4
28	10517471	2	132R	LOCKWASHER 20,2x4,5	ROSETTA DI SICUREZZA 20,2x4,5
29	11090037	2	40V	SCREW 20x2,5x185	VITE 20x2,5x185
30	11114031	2	40V	SCREW 12x1,75x90 D2936	VITE 12x1,75x90 D2936
31	11114431	1	40V	SCREW 12x1,75x110 D2936	VITE 12x1,75x110 D2936
32	11114631	1	40V	SCREW 12x1,75x120 D2936	VITE 12x1,75x120 D2936
33	11408331	4	40V	SCREW 14x1,5x35 C2936	VITE 14x1,5x35 C2936
34	11702921	2	10D	NUT 12x1,75x10 D2936	DADO 12x1,75x10 D2936
35	12163527	2	10D	NUT 20x2,5x16	DADO 20x2,5x16
36	13407211	9	60I	GREASE FITTING 10x1	INGRASSATORE 10x1
37	14171470	2	200S	PIN 8,5x75 C2936	SPINA 8,5x75 C2936

DOZER BLADE LIFTING ARMS - BRACCI SOLLEVAMENTO APRIPISTA - BRAS DE LEVAGE DE LAME
DOZER - HUBARME FUER LADESCHAUFEL - BRAZOS DE ELEVACION DE LA PALA

E3.10/8

N.T.R. 205 - 30.09.1991
604.01.081.06

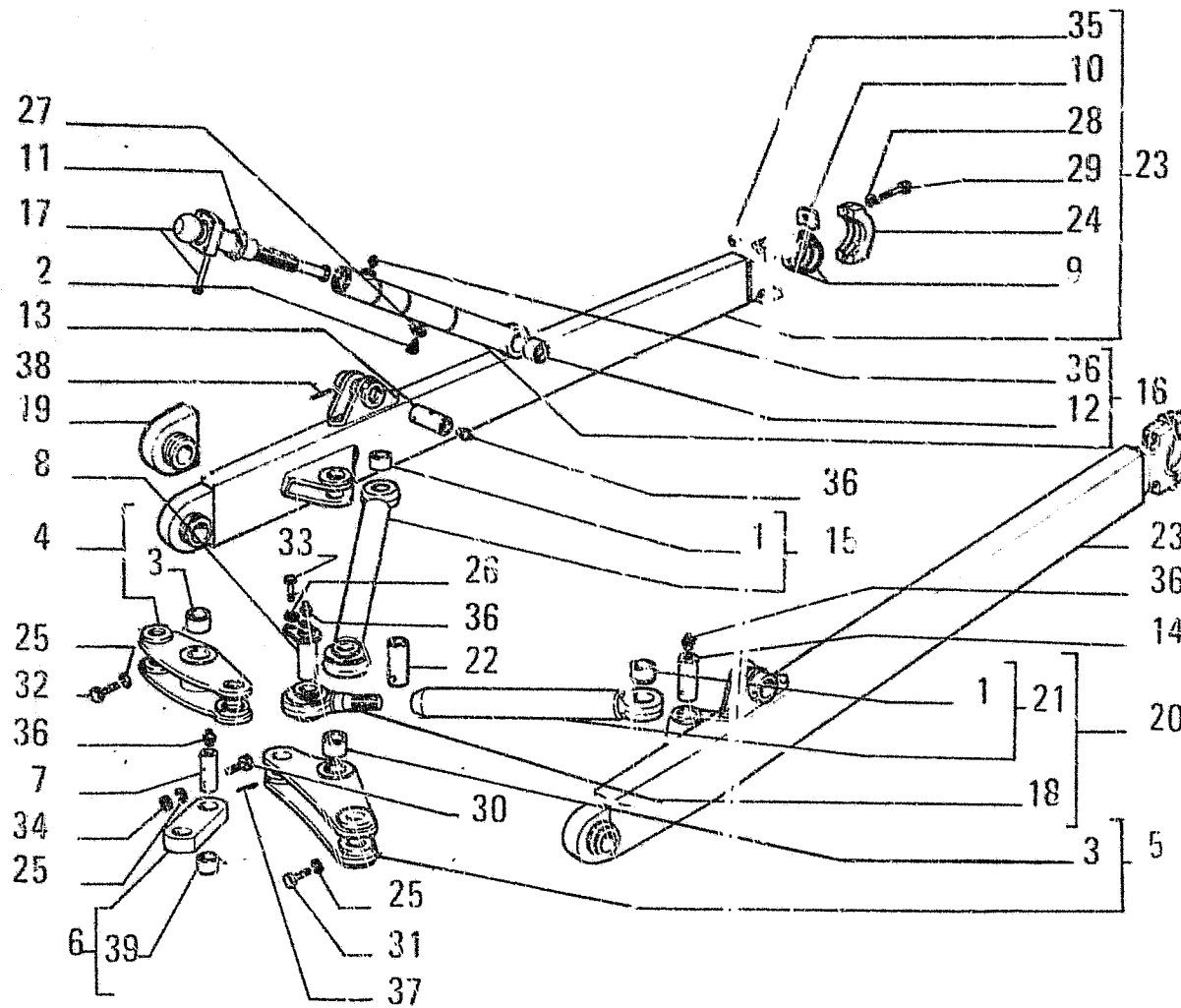

OPTIONAL VARIANTE 30.0405.03.1

ITEM	PART NUMBER	QTY	TRANS CODE	DESCRIPTION	DESCRIZIONE
1	8270124	1	95B	BUSHING - REAR	BOCCOLA - POSTERIORE
2	8280332	1	40V	SCREW	VITE
3	8280391	1	95B	BUSHING C2936	BOCCOLA C2936
	8283007	1	95B	BUSHING D2936	BOCCOLA D2936
4	8280393	1	45L	LEVER - ASSEMBLY C2936	LEVA - COMPLETO C2936
	8285652	1	45L	LEVER - ASSEMBLY D2936	LEVA - COMPLETO D2936
5	8280395	1	45L	LEVER - ASSEMBLY C2936	LEVA - COMPLETO C2936
	8295650	1	45L	LEVER - ASSEMBLY D2936	LEVA - COMPLETO D2936
6	8280397	1	50B	LINK - ASSEMBLY	BIELLA - COMPLETO
7	8280398	2	80P	PIN C2936	PERNO C2936
	8295648	2	80P	PIN D2936	PERNO D2936
8	8280400	2	80P	PIN C2936	PERNO C2936
9	8280721	1	96S	HALF BUSHING	SEMIBOCCOLA
10	8280723	2	110P	PLAQUE	PIASTRINA
11	8281853	1	42A	MUDSCRAPER RING	ANELLO RASCHIAFANGO
12	8283007	1	95B	BUSHING - REAR	BOCCOLA - POSTERIORE
13	8285654	2	80P	PIN	PERNO
14	8285655	2	80P	PIN	PERNO
15	8285656	1	142T	TIEROD - ASSEMBLY	TIRANTE - COMPLETO
16	8285707	1	141T	THREADED TIEROD - SIDE ASSEMBLY	TIRANTE FILETTATO - LATERALE COMPLETO
17	8285709	1	141T	THREADED TIEROD - SIDE	TIRANTE FILETTATO - LATERALE
18	8287899	1	141T	THREADED TIEROD - FRONT C2936	TIRANTE FILETTATO - ANTERIORE C2936
	76000304	1	141T	THREADED TIEROD - FRONT D2936	TIRANTE FILETTATO - ANTERIORE D2936
19	8288219	2	300S	SUPPORT - FRONT	SUPPORTO - ANTERIORE

DOZER BLADE LIFTING ARMS - BRACCI SOLLEVAMENTO APRIPISTA - BRAS DE LEVAGE DE LAME
 DOZER - HUBARME FUER LADESCHAUFEL - BRAZOS DE ELEVACION DE LA PALA

E3 10/8

M.T.R. 205 - 30.09.1991
 604.01.081.06

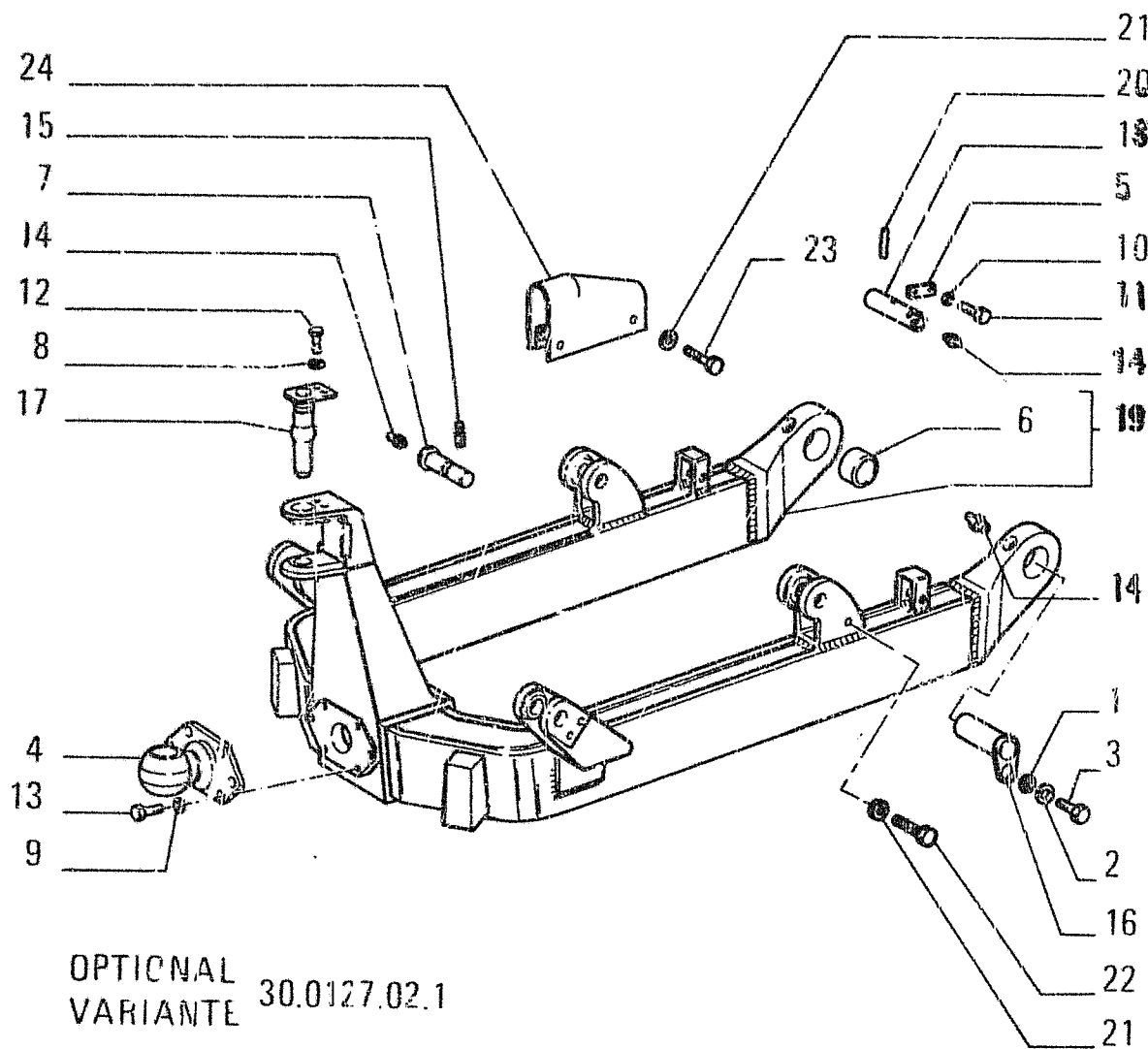

ITEM	PART NUMBER	QTY	TRANS CODE	DESCRIPTION	DESCRIZIONE
21	10516879	6	170R	LOCKWASHER 10,2x2,5 D3279	ROSETTA EL. 10,2x2,5 D3279
22	11106431	4	40V	SCREW 10x1,5x30 D3279	VITE 10x1,5x30 D3279
23	11108231	2	40V	SCREW 10x1,5x100 D3279	VITE 10x1,5x100 D3279
24	76017245	1	70R	GUARD - LEFT D3279	RIPARO - SINISTRO D3279
	76017700	1	70R	GUARD - RIGHT D3279	RIPARO - DESTRO D3279

DOZER BLADE LIFTING ARMS - BRACCI SOLLEVAMENTO APRIPISTA - BRAS DE LEVAGE DE LAME DOZER - HUBARME FUER PLANIERGERAETE - BRAZOD DE ELEVACION DEL ABRETROCHAS

E3.10/7

N.T.R. 200 - 15.10.1990

604.01.081.05

Q16

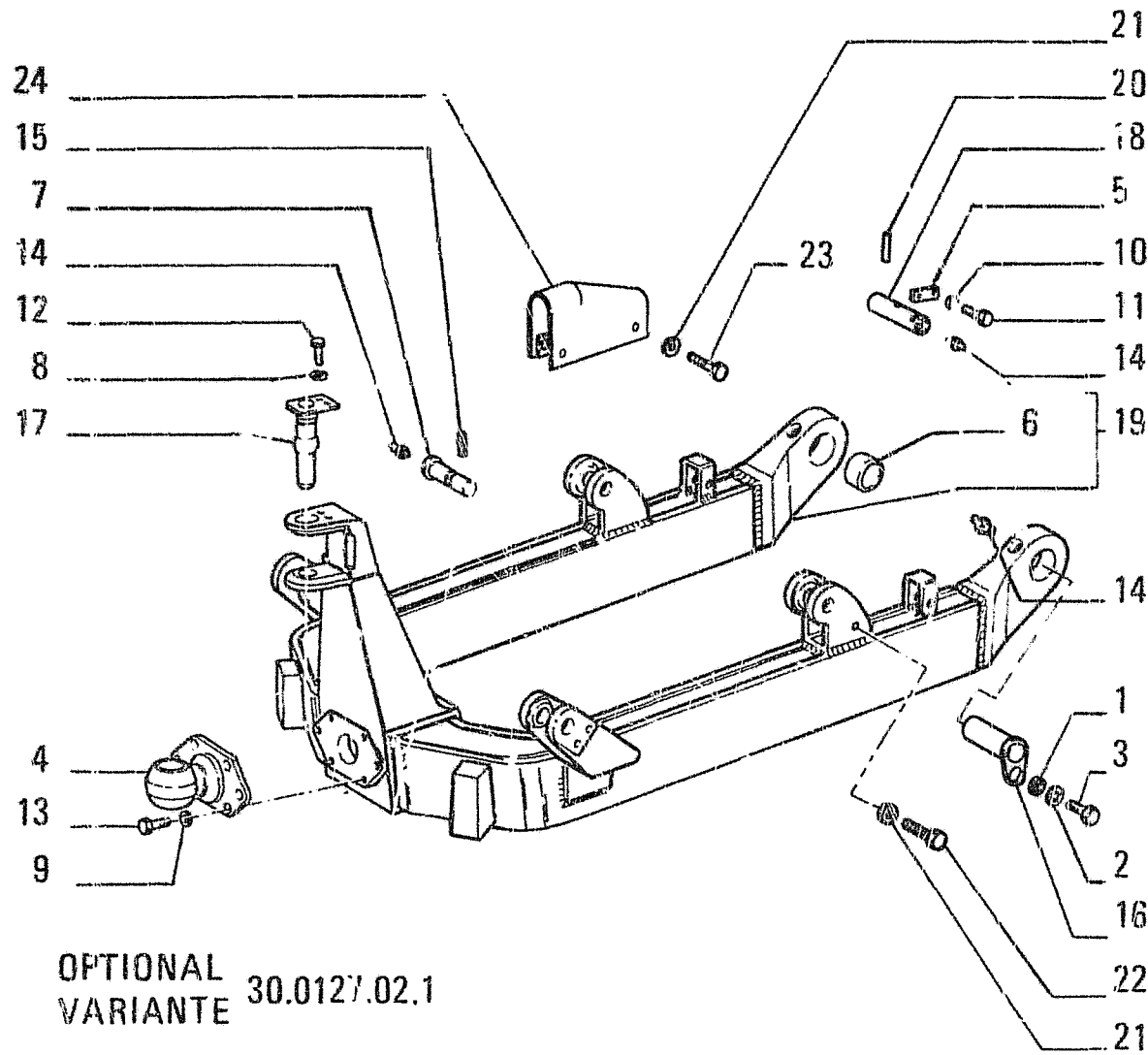

ITEM	PART NUMBER	QTY	TRANS CODE	DESCRIPTION	DESCRIZIONE
1	8296969	2	75D	SPACER	DISTANZIALE
2	8296970	2	131R	WASHER	ROSETTA
3	8296975	2	40V	SCREW	VITE
4	8297617	1	300S	SUPPORT C1620	SUPPORTO C1620
	79078990	1	300S	SUPPORT D1620	SUPPORTO D1620
5	8297638	2	110P	PLAQUE D1615	PIASTRINA D1615
6	8298667	2	95B	BUSHING	BOCCOLA
7	8298671	2	80P	PIN	PERNO
8	10517071	2	132R	LOCKWASHER 12,2x3,1	ROSETTA DI SICUREZZA 12,2x3,1
9	10517171	6	132R	LOCKWASHER 14,2x3,5	ROSETTA DI SICUREZZA 14,2x3,5
10	10571871	4	132R	LOCKWASHER 10,2x2,2 D1615	ROSETTA DI SICUREZZA 10,2x2,2 D1615
11	11106231	4	40V	SCREW 10x1,5x25 D1615	VITE 10x1,5x25 D1615
12	11112431	2	40V	SCREW 12x1,75x30	VITE 12x1,75x30
13	11115831	6	40V	SCREW 14x2x40 C2913	VITE 14x2x40 C2913
	11116031	6	40V	SCREW 14x2x45 D2913	VITE 14x2x45 D2913
14	13407211	6	60I	GREASE FITTING 10x1	INGRASSATORE 10x1
15	14604870	2	200S	PIN 6,4x60	SPINA 6,4x60
16	79027224	2	80P	PIN	PERNO
17	79031844	1	80P	PIN	PERNO
18	8298672	2	80P	PIN C1615	PERNO C1615
	79048266	2	80P	PIN D1615	PERNO D1615
19	8298668	1	81A	C-FRAME - ASSEMBLY C1615	ARCONE - COMPLETO C1615
	79048346	1	81A	C-FRAME - ASSEMBLY D1615	ARCONE - COMPLETO D1615
		1	81A	C-FRAME - ASSEMBLY C1618	ARCONE - COMPLETO C1618
	79076598	1	81A	C-FRAME - ASSEMBLY D1618	ARCONE - COMPLETO D1618
20	14604770	2	200S	PIN 6x55 C1615	SPINA 6x55 C1615

OPTIONAL VARIANTE 30.0127.02.1

DOZER BLADE LIFTING ARMS - BRACCI SOLLEVAMENTO APRIPISTA - BRAS DE LEVAGE DE LAME DOZER - HUBARME FUER PLANIERGERAETE - BRAZOS DE ELEVACION DEL ABRETROCHAS

E3.10/7
N.T.R. 200 - 15.10.1990
604.01.081.05

AUXILIARY ATTACHMENT (AND EQUIPMENT) • ORGANI SUSSIDIARI (E ATTREZZ) • ORGANES AUXILIAIRES (ET EQUIPEMENT) •
NEBENAGGREGATE (UND GERÄTE) • GRUPOS AUXILIARES (Y EQUIPO)

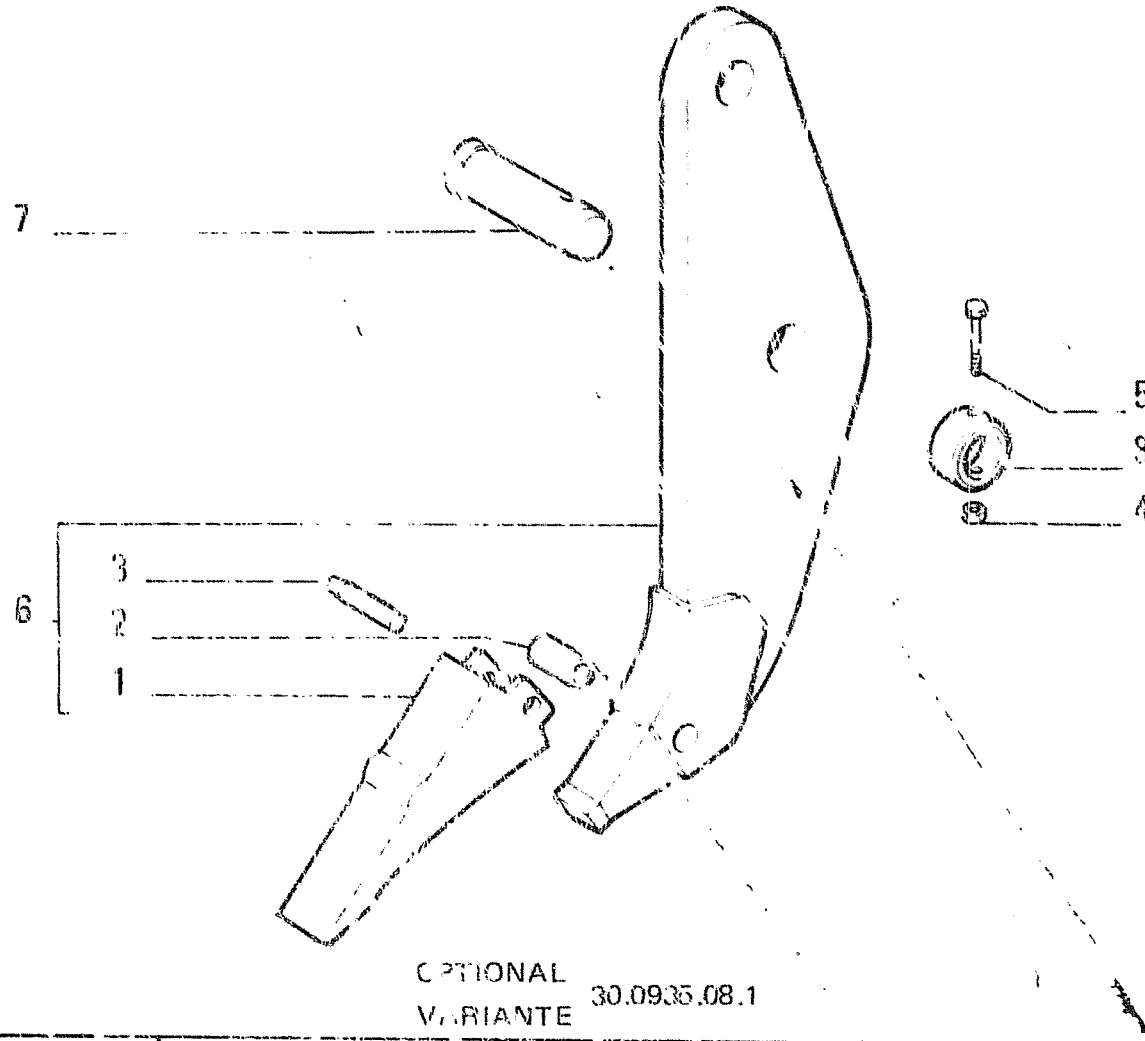

ITEM	PART NUMBER	QTY	TRANS CODE	DESCRIPTION	DESCRIZIONE
1	8282807	1	25D	RIPPER SHANK	DENTE RIPPER
2	8282809	1	200S	PIN	SPINA
3	8282170	1	80P	PIN	PERNO
4	12574321	4	10D	NUT 10x1,25x12,3	DADO 10x1,25x12,3
5	15971831	4	40V	SCREW 10x1,25x10	VITE 10x1,25x100
6	70021436	1	25D	RIPPER SHANK ASSEMBLY	DENTE RIPPER - COMPLETO
7	70030013	2	80P	PIN	PERNO
8	70070014	4	51A	LOCKRING	ANELLO DI SICUREZZA

SCARIFIER TEETH - DENTI SCARIFICATORE - DEN'S DE SCARIFICATEUR - REISSZAEHNE -
 DIENTES DE ESCARIFICADOR

E3.15

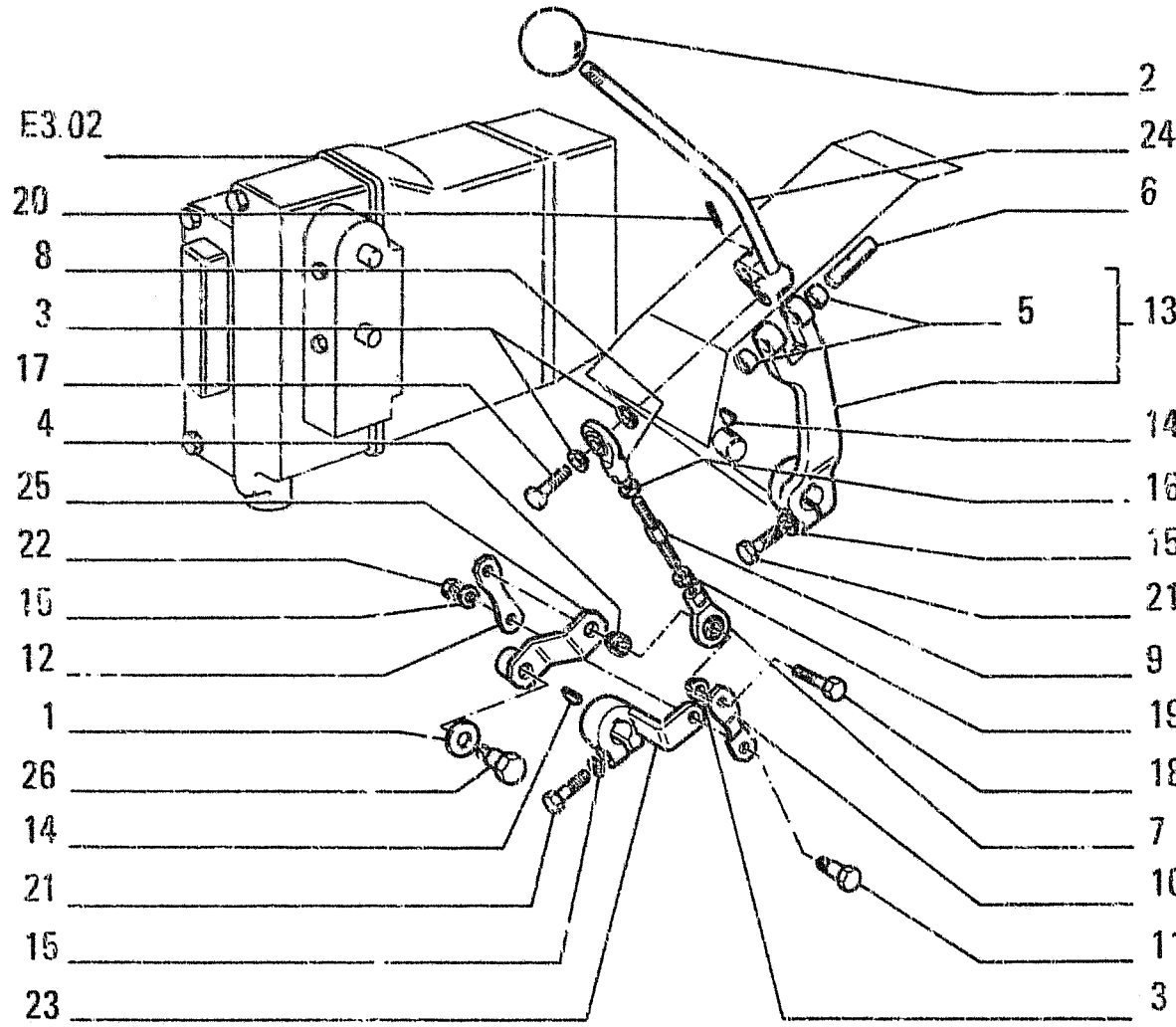

ITEM	PART NUMBER	QTY	TRANS CODE	DESCRIPTION	DESCRIZIONE
1	590523	1	131R	WASHER	ROSETTA
2	4985147	1	25I	HANDGRIP	IMPUGNATURA
3	8294287	3	75D	SPACER	DISTANZIALE
4	8296250	1	75D	SPACER	DISTANZIALE
5	8296430	2	95B	RUSHING	BOCCOLA
6	8296431	1	80C	PIN	PERNO
7	8297742	1	61E	END - LOWER	ESTREMITÀ - INFERIORE
8	8297743	1	61E	END - UPPER	ESTREMITÀ - SUPERIORE
9	8297744	1	141T	THREADED TIEROD	TIRANTE FILETTATO
10	8297751	1	60B	SHACKLE - INNER	BISCOTTINO - INTERNO
11	8297752	1	40V	SCREW	VITE
12	8297753	1	60B	SHACKLE - OUTER	BISCOTTINO - ESTERNO
13	8298969	1	45I	LEVER - ASSEMBLY	LEVA - COMPLETO
14	10205920	2	60L	KEY 9x5	LINGUETTA 9x5
15	10516671	4	132R	LOCKWASHER 8,1x2,2	ROSETTA DI SICUREZZA 8,1x2,2
16	10788721	1	10D	NUT 10x1,5x6	DADO 10x1,5x6
17	11106431	1	40V	SCREW 10x1,5x30	VITE 10x1,5x30
18	11106831	1	40V	SCREW 10x1,5x40	VITE 10x1,5x40
19	11690921	1	10D	NUT 10x1,5x6	DADO 10x1,5x6
20	14163270	1	200S	PIN 4,4x26	SPINA 4,4x26
21	16049931	2	40V	SCREW 8x1,25x35	VITE 8x1,25x35
22	16102321	1	10D	NUT 8x1,25x5	DADO 8x1,25x5
23	76004175	1	45L	LEVER	LEVA
24	79022250	1	45L	LEVER	LEVA
25	79022251	1	60B	SHACKLE	BISCOTTINO
26	79022254	1	40V	SCREW	VITE

IMPLEMENT CONTROL SYSTEM — COMANDO ATTREZZO
 GERÄTEBETAETIGUNG — ACCIONAMIENTO DEL ÚTIL

— COMMANDE DE L'OUTIL —

E3.25

1

RS

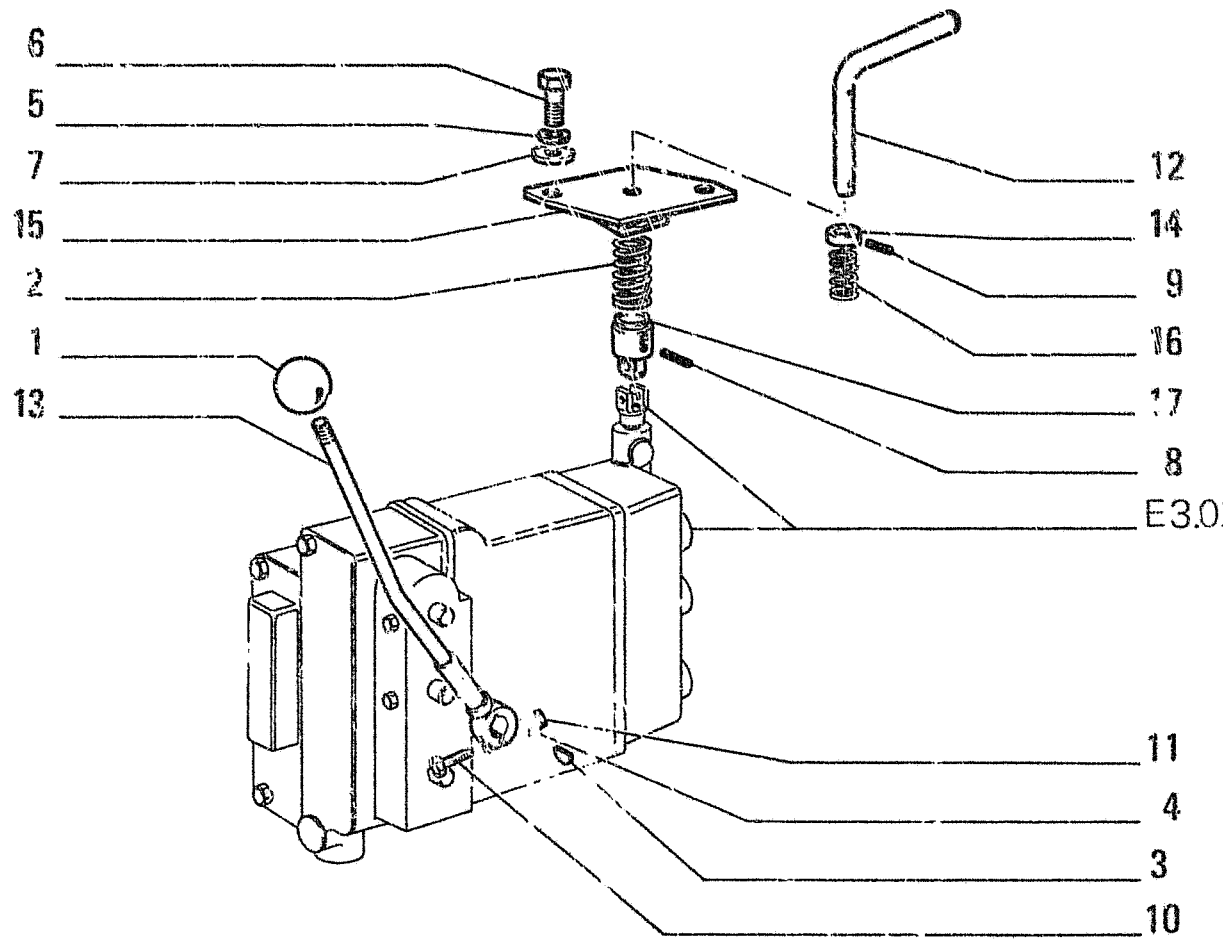

ITEM	PART NUMBER	QTY	TRANS CODE	DESCRIPTION	DESCRIZIONE
1	4985147	1	25I	HANDGRIP	IMPUGNATURA
2	8299095	1	100M	SPRING	MOLLA
3	10205920	1	60L	KEY 9x5	LINGUETTA 9x5
4	10516671	1	131R	WASHER 8,1x2,2	ROSETTA 8,1x2,2
5	10516871	3	132R	LOCKWASHER 10x2,5	ROSETTA DI SICUREZZA 10x2,5
6	11106031	2	40V	SCREW 10x1,5x20	VITE 10x1,5x20
7	12646801	2	131R	WASHER 10,2x2,5	ROSETTA 10,2x2,5
8	14162270	1	200S	PIN 3,3x28	SPINA 3,3x28
9	14601270	2	200S	PIN 5x28	SPINA 5x28
10	16044131	1	40V	SCREW 8x1,25x45	VITE 8x1,25x45
11	16100821	1	10D	NUT 8x1,25x6,5	DADO 8x1,25x6,5
12	79028262	1	45L	LEVER	LEVA
13	79031633	1	45L	LEVER	LEVA
14	79033661	1	45A	RING	ANELLO
15	79033672	1	300S	SUPPORT	SUPPORTO
16	79033674	1	100M	SPRING	MOLLA
17	79028263	1	45L	LEVER	LEVA

IMPLEMENT CONTROL SYSTEM - COMANDO ATTREZZO
 GERAETEBETAERIGUNG - ACCIONAMIENTO DEL ÚTIL

COMMANDE DE L'OUTIL

E3.25

2

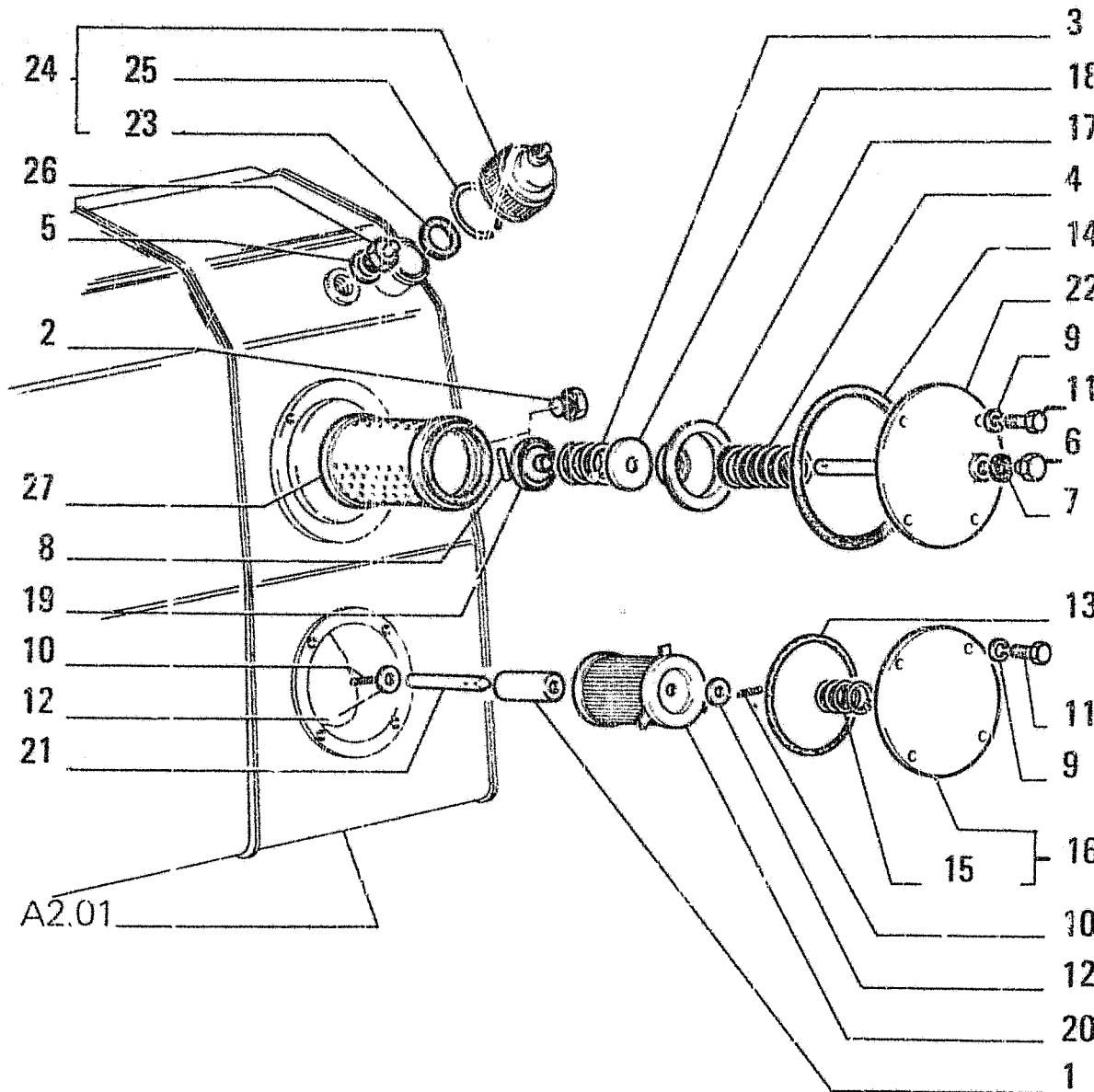

ITEM	PART NUMBER	QTY	TRANS CODE	DESCRIPTION	DESCRIZIONE
1	581492	1	54C	MAGNETIC ROD	CANDELA MAGNETICA
2	4967197	3	31I	LEVEL GAUGE C3215	INDICATORE LIVELLO C3215
	79103405	3	31I	LEVEL GAUGE D3215	INDICATORE LIVELLO D3215
3	4976532	1	100M	SPRING	MOLLA
4	4992088	1	100M	SPRING	MOLLA
5	10263460	1	133R	SEAL 22,2x28	ROSETTA DI TENUTA 22,2x28
6	10119040	2	50T	PLUG 27x2x16 D2907	TAPPO 27x2x16 D2907
	10278301	2	56T	DRAIN PLUG 28x1,5x11 C2907	TAPPO DI SCARICO 28x1,5x11 C2907
7	10296585	2	133R	SEAL 28,3x36 C2907	ROSETTA DI TENUTA 28,3x36 C2907
8	10332810	1	80P	PIN 3x25	PERNO 3x25
9	10516871	8	132R	LOCKWASHER 10x2,5	ROSETTA DI SICUREZZA 10x2,5
10	10796401	2	270C	COTTER PIN 2,7x27,6	COPIGLIA 2,7x27,6
11	11106031	8	40V	SCREW 10x1,5x20	VITE 10x1,5x20
12	12638621	2	131R	WASHER 10,2x18	ROSETTA 10,2x18
13	14466880	1	158G	O-RING 3,53x126,59	GUARNIZIONE O-R 3,53x126,59
14	14468280	1	158G	O-RING 3,53x190,1	GUARNIZIONE O-R 3,53x190,1
15	79006212	1	100M	SPRING	MOLLA
16	79006358	1	265.	COVER - ASSEMBLY	COPERCHIO - COMPLETO
17	79010369	1	80F	BOTTOM PLATE	FONDELLO
18	79010375	1	60D	DISC	DISCO
19	79010377	1	60S	CLIP	SCODELLINO
20	79012205	1	20E	FILTERING ELEMENT	ELEMENTO FILTRANTE
21	79012207	1	80P	PIN	PERNO
22	76015682	1	265C	COVER D2907	COPERCHIO D2907
	79015263	1	265C	COVER C2907	COPERCHIO C2907

OIL TANK - SERBATOIO OLIO - RESERVOIR D'HUILE - OELBEHAELTER - DEPOSITO DE ACEITE

E3.28

N.T.R. 200 - 15.10.1990

604.01.081.05

R5

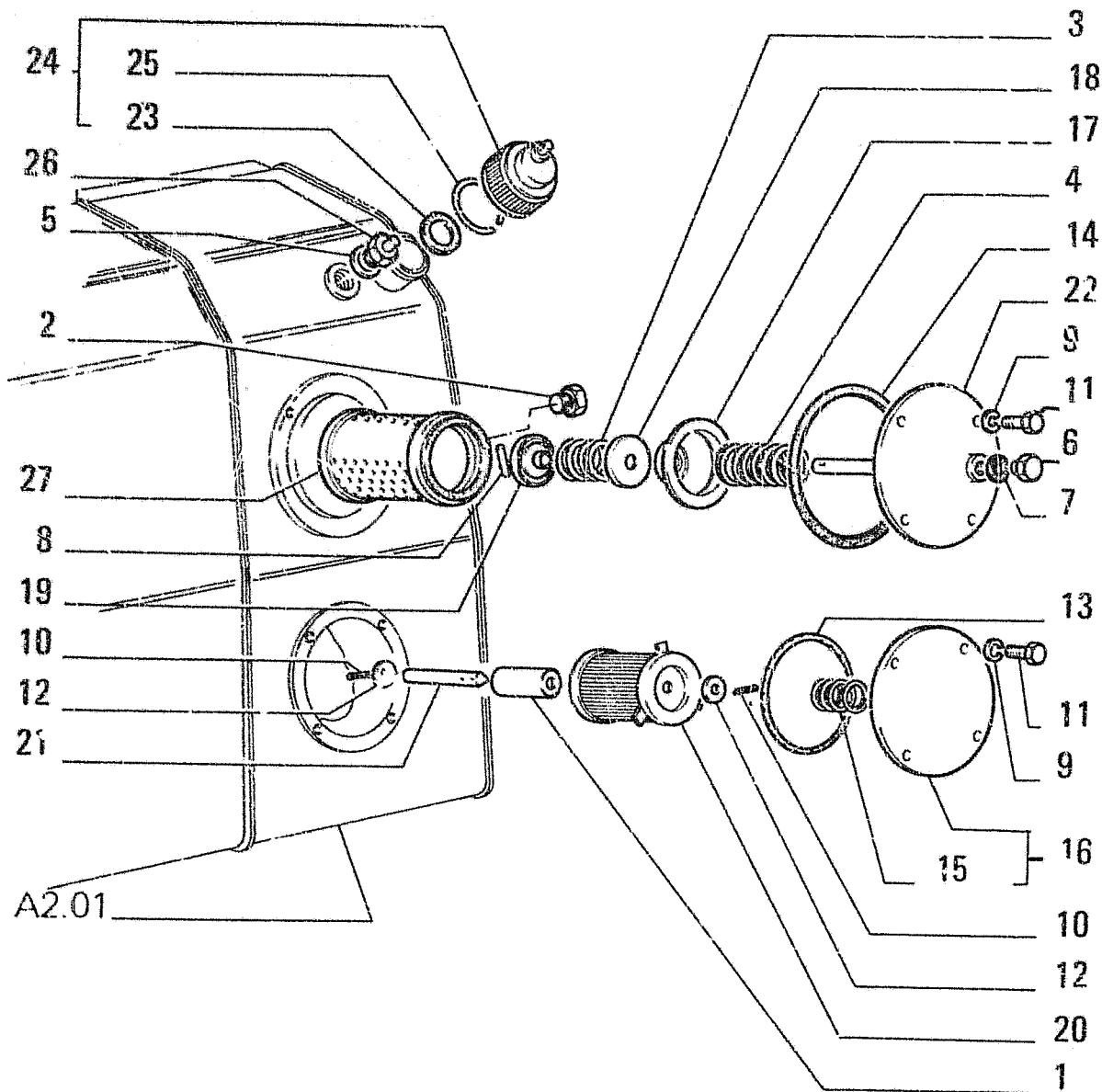

FIATALLIS FD7

E3.28 TAV. 1 PAG.2

ITEM	PART NUMBER	QTY	TRANS CODE	DESCRIPTION	DESCRIZIONE
23	79019060	1	133R SEAL		ROSETTA DI TENUTA
24	79019062	1	50T PLUG - ASSEMBLY G2915		TAPPO - COMPLETO G2915
	79093835	1	50T PLUG D2915		TAPPO D2915
25	79019065	1	51A LOCKRING		ANELLO D' SICUREZZA
26	79028299	1	10V VALVE		VALVOLA
27	79032087	1	20F FILTERING ELEMENT		ELEMENTO FILTRANTE

OIL TANK - SERBATOIO OLIC - RESERVOIR D'HUILE - OELBEHAELTER - DEPOSITO DE ACEITE

E3.28

N.T.R. 200 - 15.10.1990
604.01.081.05

R6

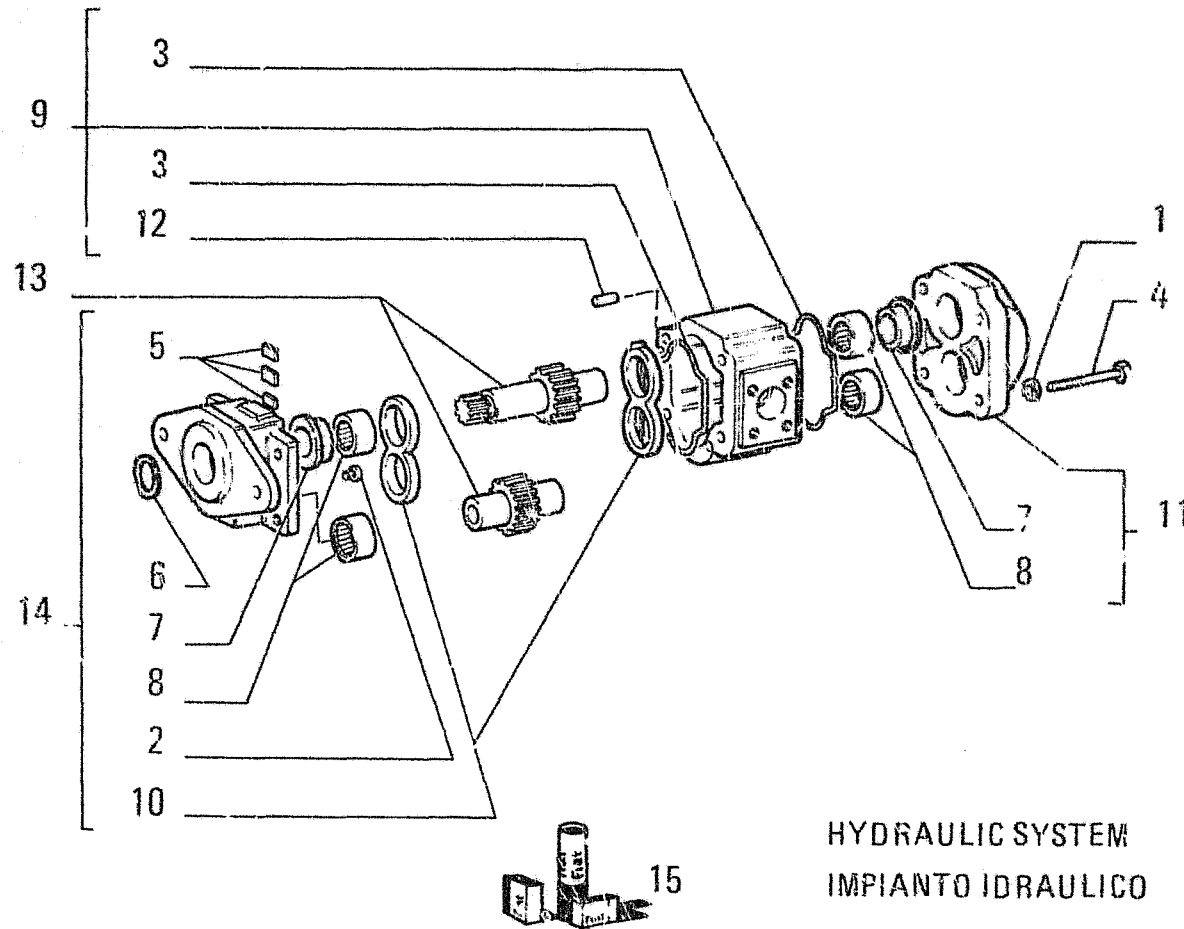

ITEM	PART NUMBER	QTY	TRANS CODE	DESCRIPTION	DESCRIZIONE
1	70659494	4	131R	WASHER	ROSETTA
2	70669623	1	50T	PLUG	TAPPO
3	70926913	2	158G	O-RING	GUARNIZIONE O-R
4	70929030	4	40V	SCREW	VITE
5	73044040	12	158G	O-RING	GUARNIZIONE O-R
6	73045975	1	133R	SEAL	ROSETTA DI TENUTA
7	73045976	2	133R	SEAL	ROSETTA DI TENUTA
8	73045977	4	341C	BEARING	CUSCINETTO
9	79030474	1	300C	BODY - ASSEMBLY	CORPO - COMPLETO
10	79030475	2	70F	FLANGE	FLANGIA
11	79030476	1	265C	COVER - REAR ASSEMBLY	COPERCHIO - POSTERIORE COMPLETO
12	79030477	4	80P	PIN	PERNO
13	79030478	1	286C	GEAR SET	COPPIA DI INGRANAGGI
14	79030479	1	265C	COVER - FRONT ASSEMBLY	COPERCHIO - ANTERIORE COMPLETO
15	79032513	1	1K	KIT SEE PAGE 9	KIT VED. PAG.9
	79032514	1	1K	KIT SEE PAGE 9	KIT VED. PAG.9

8297172
 PUMP - POMPA - POMPE - PUMPE - BOMBA

E3.29
 N.T.R. 191 - 20.02.1990
 604.01.081.04

R7

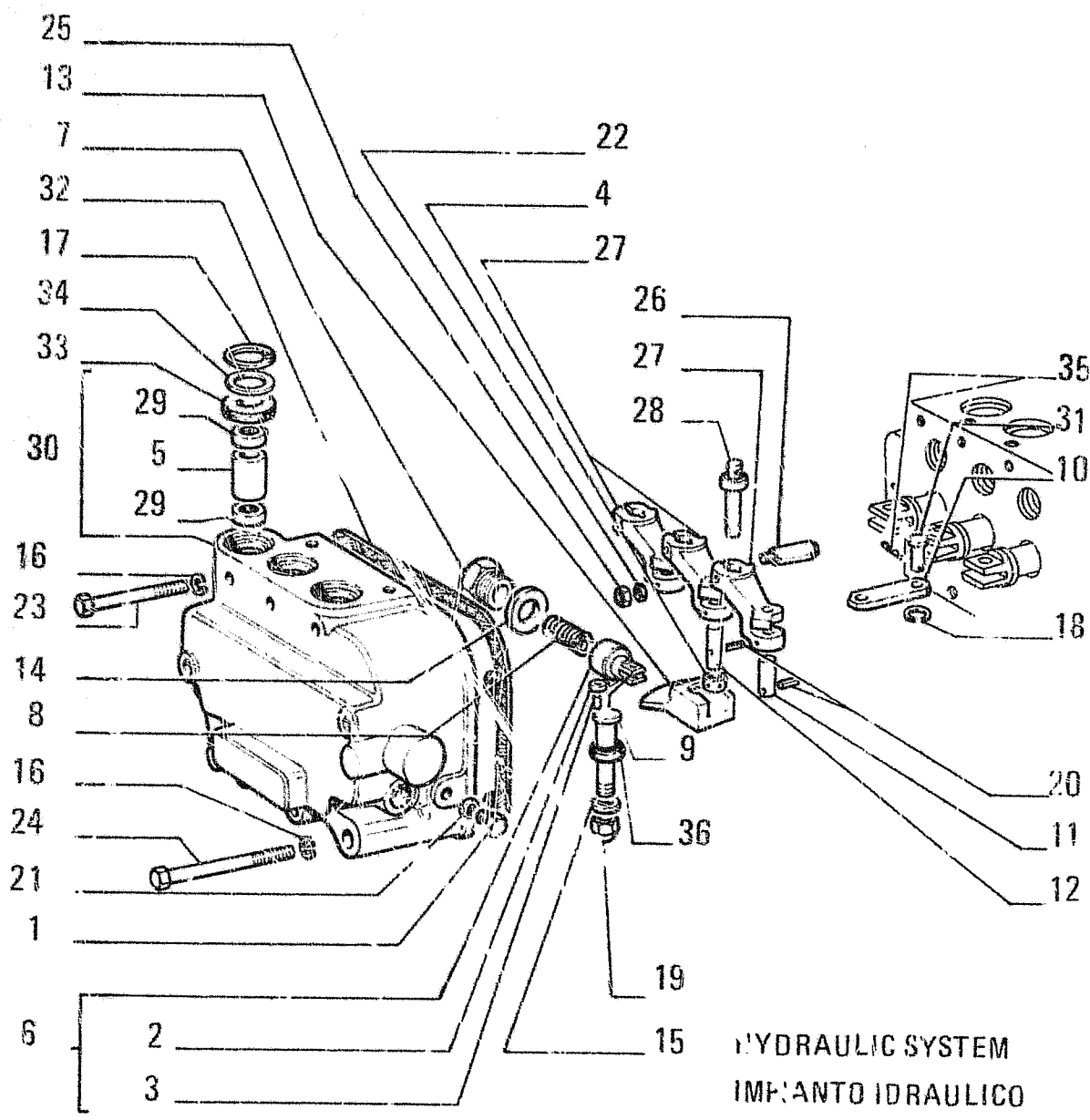

FIATALLIS FD7

ITEM	PART NUMBER	QTY	TRANS CODE	DESCRIPTION	DESCRIZIONE
1	581658	1	50T	PLUG	TAPPO
2	4989258	1	157R	ROLLER	RULLO
3	4989261	1	80P	PIN	PERNO
4	8295865	1	341C	BEARING	CUSCINETTO
5	8295964	3	75D	SPACER	DISTANZIALE
6	8295975	1	130P	PLUNGER - ASSEMBLY	PISTONCINO - COMPLETO
7	8295976	1	50T	PLUG	TAPPO
8	8295977	1	100M	SPRING	MOLLA
9	8295984	1	80P	PIN	PERNO
10	8295989	3	60B	SHACKLE	BISCOTTINO
11	8295991	2	80P	PIN	PERNO
12	8295992	1	80P	PIN	PERNO
13	8296630	1	63R	BELL CRANK	RINVIO
14	10284560	1	133R	SEAL 24,3x32	ROSETTA DI TENUTA 24,3x32
15	10284460	1	133R	SEAL 10,2x16	ROSETTA DI TENUTA 10,2x16
16	10516671	9	132R	LOCKWASHER 8,1x2,2	ROSETTA DI SICUREZZA 8,1x2,2
17	11059776	3	45A	RING 40,8x1,5	ANELLO 40,8x1,5
18	11087976	3	51A	LOCKRING 7x14 D1159	ANELLO DI SICUREZZA 7x14 D1159
19	14054911	1	10D	NUT 10x1,25x19	DADO 10x1,25x19
20	14161970	3	200S	PIN 3,3x20	SPINA 3,3x20
21	14330260	1	133R	SEAL 8,2x12	ROSETTA DI TENUTA 8,2x12
22	14406521	3	131R	WASHER 3,4x17	ROSETTA 8,4x17
23	16044931	3	40V	SCREW 8x1,25x85	VITE 8x1,25x85
24	16045131	6	40V	SCREW 8x1,25x95	VITE 8x1,25x95
25	16100821	3	10D	NUT 8x1,25x6,5	DADO 8x1,25x6,5
26	79022824	3	80P	PIN	PERNO

79027108 - 79041699
 DISTRIBUTOR VALVE - DISTRIBUTORE - DISTRIBUTEUR - STUERGERAET - DISTRIBUIDOR

E3.31 1
 N.T.R. 152 - 28.11 1986
 604.01.081.02

R8

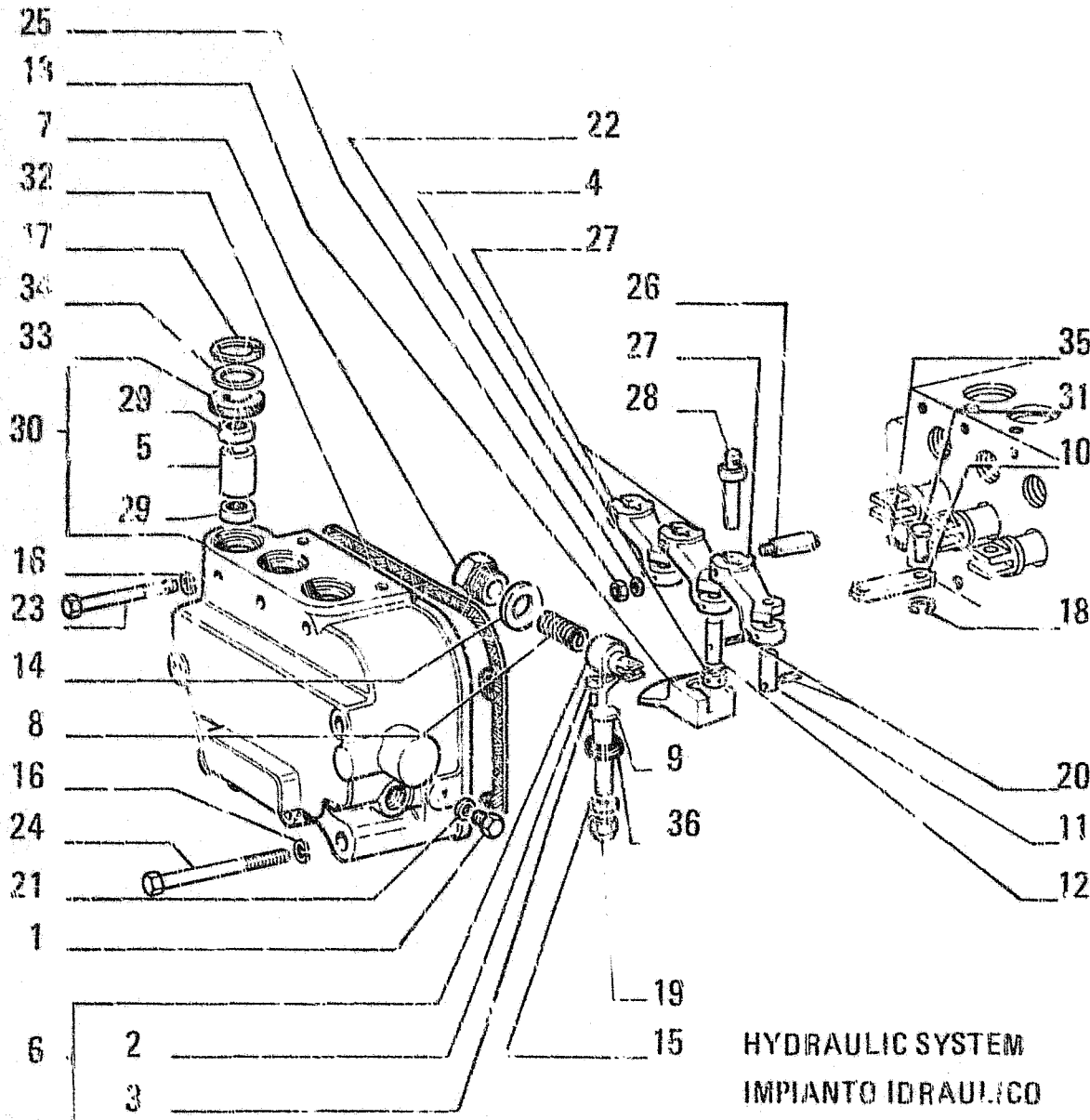

ITEM	PART NUMBER	QTY	TRANS CODE	DESCRIPTION	DESCRIZIONE
27	79022826	3	4SL	LEVER	LEVA
28	79022827	3	90P	PIN	PERNO
27	79034477	6	341C	BEARING	CUSCINETTO
30	8296629	1	205C	COVER - FRONT ASSEMBLY C1159	COPERCHIO - ANTERIORE COMPLETO C1159
	79040776	1	205C	COVER - FRONT ASSEMBLY D1159	COPERCHIO - ANTERIORE COMPLETO D1159
31	8295969	3	00P	PIN C1159	PERNO C1159
	79040777	3	00P	PIN D1159	PERNO D1159
32	8295968	1	123C	SEAL ASSY C1159	GUARNIZIONE TENUTA FRONTALE C1159
	79040784	1	123C	SEAL ASSY D1159	GUARNIZIONE TENUTA FRONTALE D1159
33	79045951	3	158G	O-RING	GLARNIZIONE O-R
34	79045852	3	131R	WASHER	ROSETTA
35	10734201	3	270C	COTTER PIN 1,7x18,5 C1159	COPIGLIA 1,7x18,5 C1159
36	14489121	1	132R	LOCKWASHER 10,5x18 D1159	ROSETTA DI SICUREZZA 10,5x18 D1159

79077108 - 79041609
 DISTRIBUTOR VALVE - DISTRIBUTORE - DISTRIBUTEUR - STUERGERAET - DISTRIBUIDOR

1	E3.31	1
N.T.R. 152 - 28.11.1936		
604.01.081.02		

R9

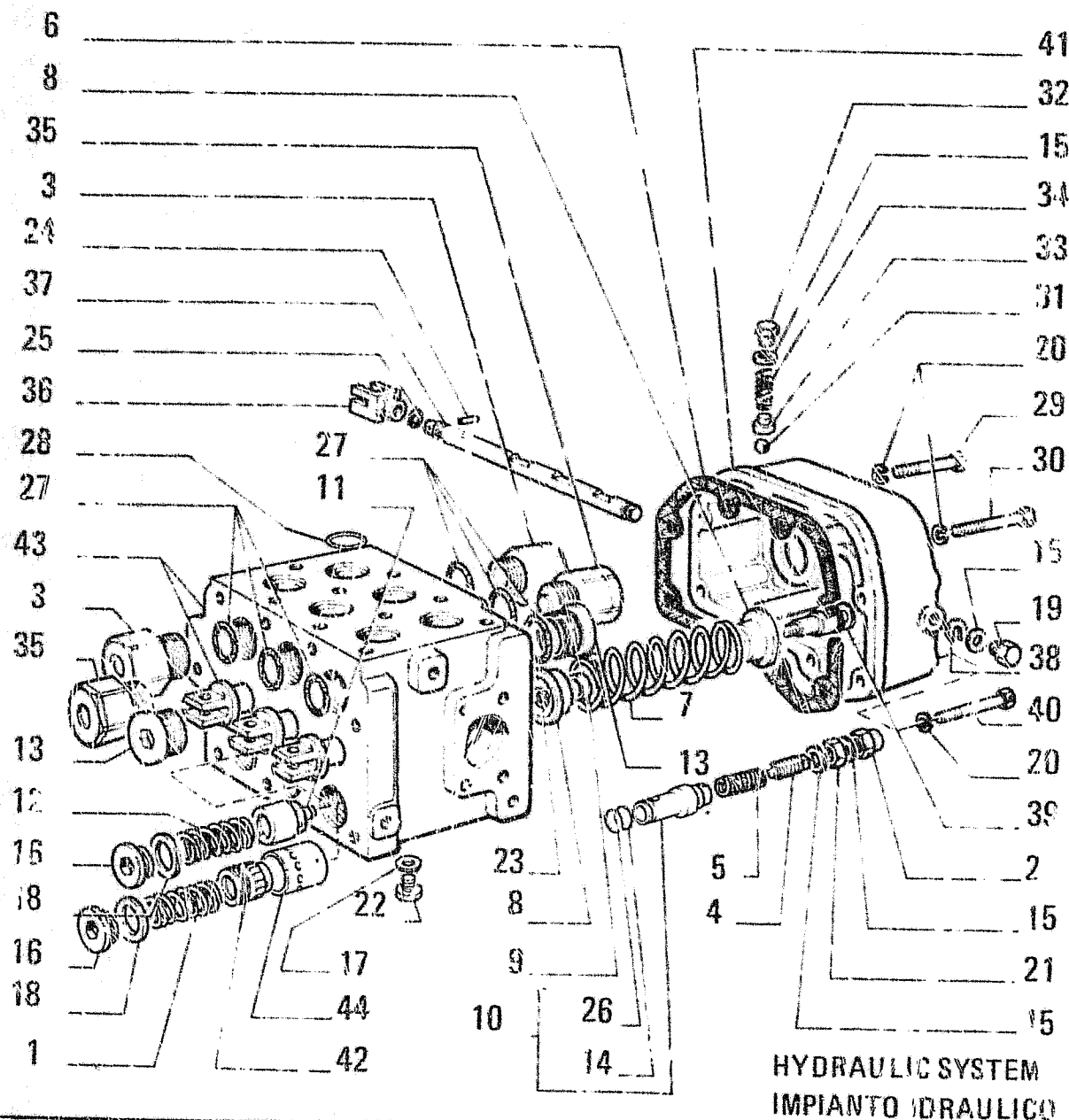

HYDRAULIC SYSTEM
IMPIANTO IDRAULICO

FIAT ALLIS FD7

ITEM	PART NUMBER	QTY	TRANS CODE	DESCRIPTION	DESCRIZIONE
1	591107	1	100M SPRING D1159		MOLLA D1159
2	8273489	1	50T PLUG		TAPPO
3	8281250	2	10V VALVE		VALVOLA
4	8287304	1	40V SCREW		VITE
5	8287305	1	100M SPRING		MOLLA
6	8295967	1	123G SEAL ASSY		GUARNIZIONE TENUTA FRONTALE
7	8295970	3	100M SPRING		MOLLA
8	8295971	6	60S CUP		SCODELLINO
9	8295973	2	75D SPACER		DISTANZIALE
10	8295981	1	10V VALVE - ASSEMBLY		VALVOLA - COMPLETO
11	8295982	2	10V VALVE		VALVOLA
		1	10V VALVE C1159		VALVOLA C1159
12	8295983	2	100M SPRING		MOLLA
		1	100M SPRING C1159		MOLLA C1159
13	8295995	2	50T PLUG		TAPPO
14	8298503	1	45A RING		ANELLO
15	10257060	5	133R SEAL 16,2x22		ROSETTA DI TENUTA 16,2x22
16	10278311	2	50T PLUG 28x1,5x11		TAPPO 28x1,5x11
17	10296160	3	133R SEAL 12,2x18		ROSETTA DI TENUTA 12,2x18
18	10296280	3	133R SEAL 28,3x36		ROSETTA DI TENUTA 28,3x36
19	10300721	1	50T PLUG 16x1,5x9		TAPPO 16x1,5x9
20	10316671	7	132R LOCKWASHER 8,1x2,2		ROSETTA DI SICUREZZA 8,1x2,2
21	10791411	1	10D NUT 16x1,5x8		DADO 16x1,5x8
22	11903211	3	50T PLUG 12x1,25x8		TAPPO 12x1,25x8
23	12605671	3	131R WASHER 10,2x17,8		ROSETTA 10,2x17,8
24	14161970	1	200S PIN 3,3x10		SPINA 3,3x10
25	14452980	1	158G O-RING 1,78x9,25		GUARNIZIONE O-R 1,78x9,25

79027108 - 79041699

DISTRIBUTOR VALVE - DISTRIBUTORE - DISTRIBUTEUR - STUERGERAET - DISTRIBUIDOR

1

E3.31

2

N.T.R. 191 - 20.02.1990

604.C1.081.04

R10

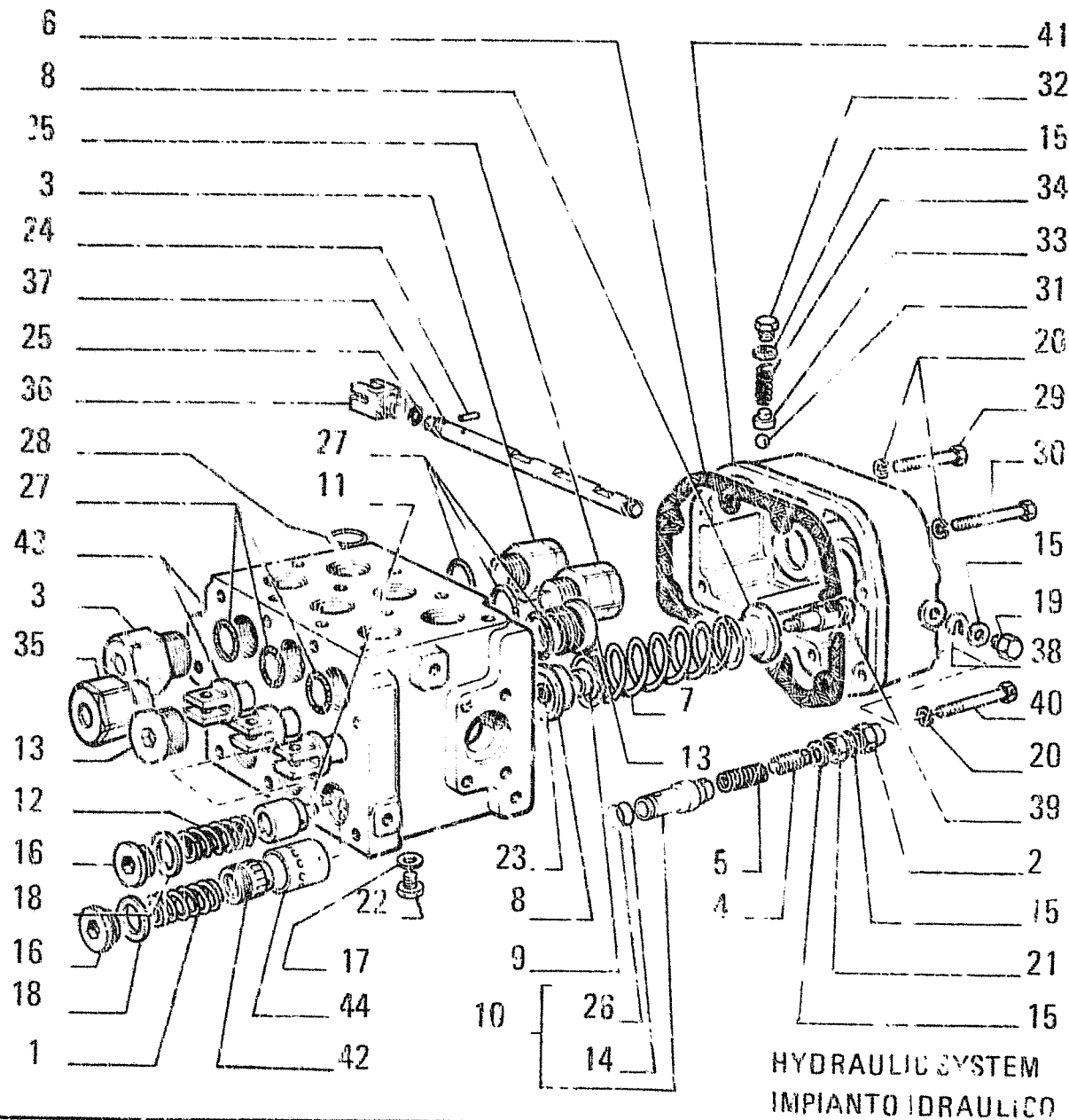

FIATALLIS FD7

ITEM	PART NUMBER	QTY	TRANS CODE	DESCRIPTION	DESCRIZIONE
25	14457580	1	158G	O-RING 2,62x20,29	GUARNIZIONE O-R 2,62x20,29
27	14457680	6	158G	O-RING 2,62x21,89	GUARNIZIONE O-R 2,62x21,89
28	14463280	6	158G	O-RING 3,53x24,99	GUARNIZIONE O-R 3,53x24,99
29	16044731	4	40V	SCREW 8x1,25x75	VITE 8x1,25x75
30	16044931	3	40V	SCREW 8x1,25x85	VITE 8x1,25x85
31	20063440	2	140S	BALL 5,556	SFERA 5,556
32	79003603	2		50T PLUG	TAPPO
33	79010455	2		80P PIN	PERNO
34	79011775	2		100M SPRING	MOLLA
35	79022904	2		10V VALVE	VALVOLA
36	79027076	1		85F YOKE	FORCELLA
37	79027077	1		80P PIN	PERNO
38	79027078	1		131R WASHER	ROSETTA
39	79027079	3		40V SCREW	VITE
40	79027263	1		40V SCREW	VITE
41	79027080	1		265C COVER - REAR C1159	COPERCHIO - POSTERIORE C1159
	79040769	1		265C COVER - REAR D1159	COPERCHIO - POSTERIORE D1159
42	79041704	1		120P PLUNGER D1159	PISTONCINO D1159
43	8295960	1		303C BODY - ASSEMBLY C1159	CORPO - COMPLETO C1159
	79041702	1		300C BODY - ASSEMBLY D1159	CORPO - COMPLETO D1159
		1		300C BODY - ASSEMBLY C1162	CORPO - COMPLETO C1162
	79045694	1		300C BODY - ASSEMBLY D1162	CORPO - COMPLETO D1162
44	79041703	1		95B BUSHING D1159	BOCCOLA D1159
		1		95B BUSHING C1162	BOCCOLA C1162
	79045695	1		95B BUSHING D1162	BOCCOLA D1162

79027108-79041699

DISTRIBUTOR VALVE - DISTRIBUTORE - DISTRIBUTEUR - STUERGERAET - DISTRIBUTOR

1

E3.31

2

M.T.R. 191 - 20.02.1990

604.01.081.04

R11

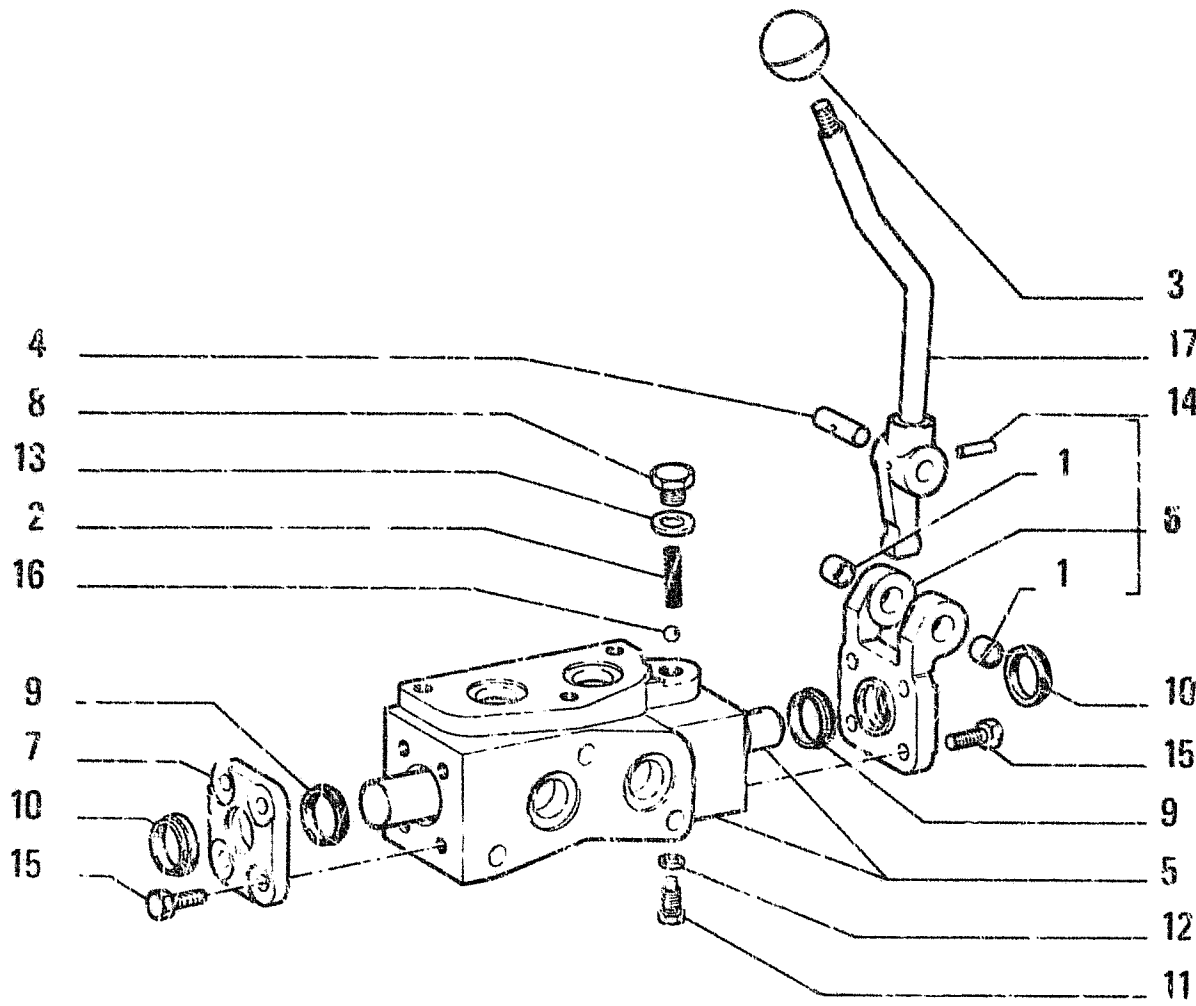

ITEM	PART NUMBER	QTY	TRANS CODE	DESCRIPTION	DESCRIZIONE
1	4177981	2	95B	BUSHING	BOCCOLA
2	8280745	1	100M	SPRING	MOLLA
3	8292689	1	25'	HANDGRIP	IMPUGNATURA
4	8293970	1	8SP	PIN	PERNO
5	8296667	1	300C	RODY	CORPO
6	8296669	1	285C	COVER - FRONT / ASSEMBLY	COPERCHIO - ANTERIORE COMPLETO
7	8296670	1	265C	COVER - REAR	COPERCHIO - POSTERIORE
8	8296672	1	50T	PLUG	TAPPO
9	8296676	2	158G	O-RING	GUARNIZIONE O-R
10	8296677	2	159C	O-RING	GUARNIZIONE O-R
11	8296678	1	4LV	SCREW	VITE
12	10260060	1	133R	SEAL 8,2x14	ROSETTA DI TENUTA 8,2x14
13	10280060	1	133R	SEAL 14,2x20	ROSETTA DI TENUTA 14,2x20
14	14164070	1	200S	PIN 4,4x22	SPINA 4,4x22
15	14237930	8	40V	SCREW 8x1,25x18	VITE 8x1,25x18
16	20063470	1	140S	BALL 7,938	SFERA 7,938
17	79022291	1	45L	LEVER	LEVA

Optional 30.0090.10.1
Variante

DIVERTOR VALVE
VÁLVULA BY-PASS

8296665
DEVIATORE IDRAULICO

DEVIATEUR - UMGEHUNGSVENTIL

2

E3.31/1

N.T.R. 158 - 13.03.1987
604.01.081.03

R12

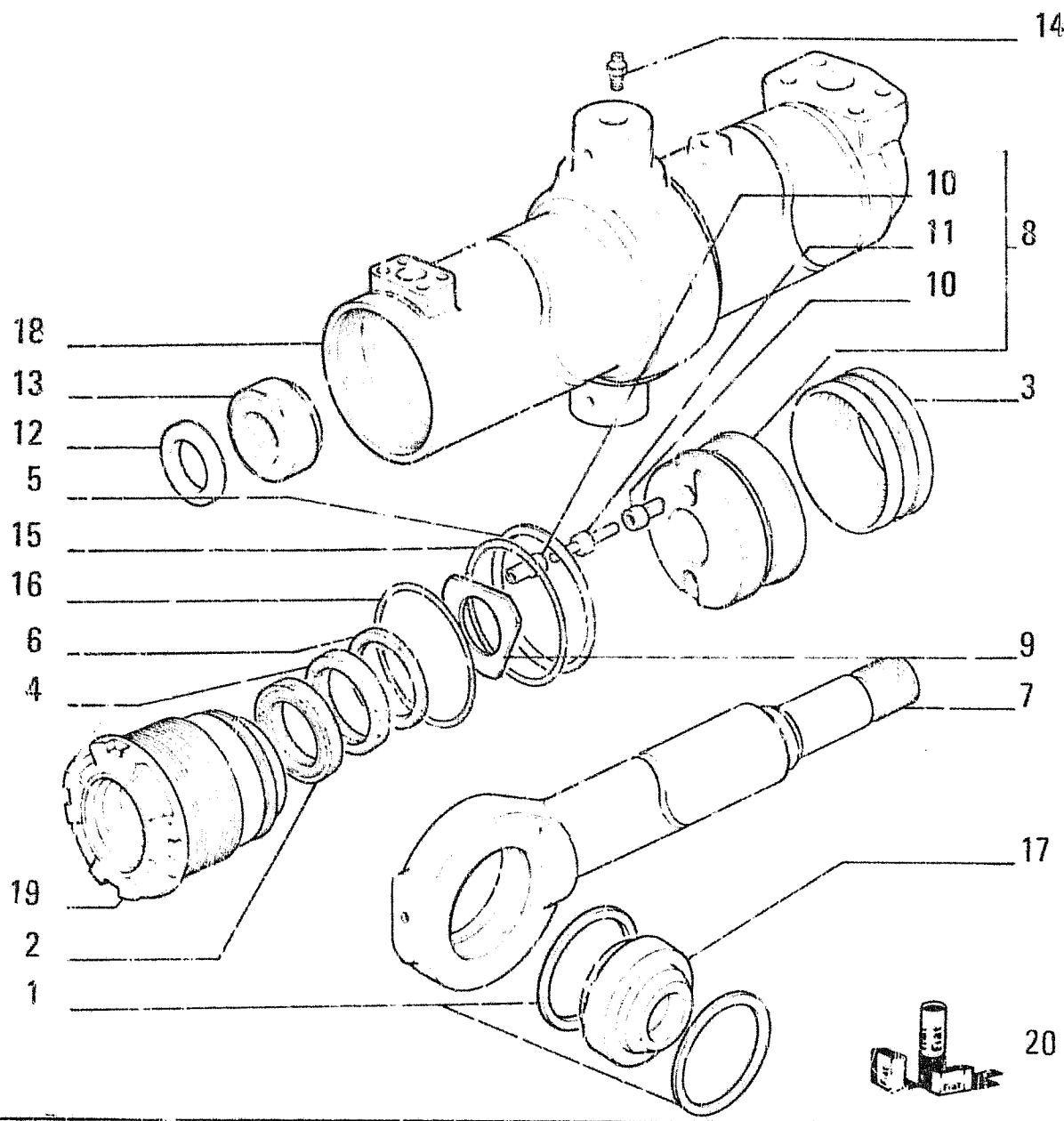

FIATALLIS FD7

ITEM	PART NUMBER	QTY	TRANS CODE	DESCRIPTION	DESCRIZIONE
1	8280835	2	51A	LOCKRING	ANELLO DI SICUREZZA
2	8280822	1	122G	SEAL C2916	GUARNIZIONE C2916
	79065558	1	122G	SEAL D2910	GUARNIZIONE D2910
3	8291506	1	158G	O-RING	GUARNIZIONE O-R
4	8297294	1	158G	O-RING C2916	GUARNIZIONE O-R C2916
	79065558	1	45A	RING D2916	ANELLO D2916
5	8297295	1	45A	RING	ANELLO
6	8297296	1	158G	O-RING C2916	GUARNIZIONE O-R C2916
	79065557	1	122G	SEAL D2916	GUARNIZIONE D2916
7	8298586	1	274S	ROD	STELO
8	8298590	1	235S	PISTON - ASSEMBLY	STANTUFFO - COMPLETO
9	8298606	1	60D	DISC	DISCO
10	8298607	4	147G	SPRING GUIDE	GUIDA DELLA MOLLA
11	8298608	2	10V	VALVE	VALVOLA
12	8298609	1	131R	WASHER	ROSETTA
13	12575127	1	10D	NUT 20x1,5x23	DADO 20x1,5x23
14	13407211	2	60I	GREASE FITTING 10x1	INGRASSATORE 10x1
15	14465180	1	158G	O-RING 3,53x72,62	GUARNIZIONE O-R 3,53x72,62
16	14465480	1	158G	O-RING 3,53x82,14	GUARNIZIONE O-R 3,53x82,14
17	79036604	1	341C	BEARING	CIUSCINETTO
18	79039429	1	53C	TUBE	CANNA CILINDRO
19	79038729	1	80F	BOTTOM PLATE - FRONT C1612	FONDELLO - ANTERIORE C1612
	79047725	1	80F	BOTTOM PLATE - FRONT D1612	FONDELLO - ANTERIORE D1612
		1	80F	BOTTOM PLATE - FRONT C2948	FONDELLO - ANTERIORE C2948

79039427-79047903-76016701
 CYLINDER - CILINDRO - CYLINDRE - ZYLINDER - CILINDRO

1
 E3.32
 N.T.R. 191 - 20.02.1990
 604.01.081.04

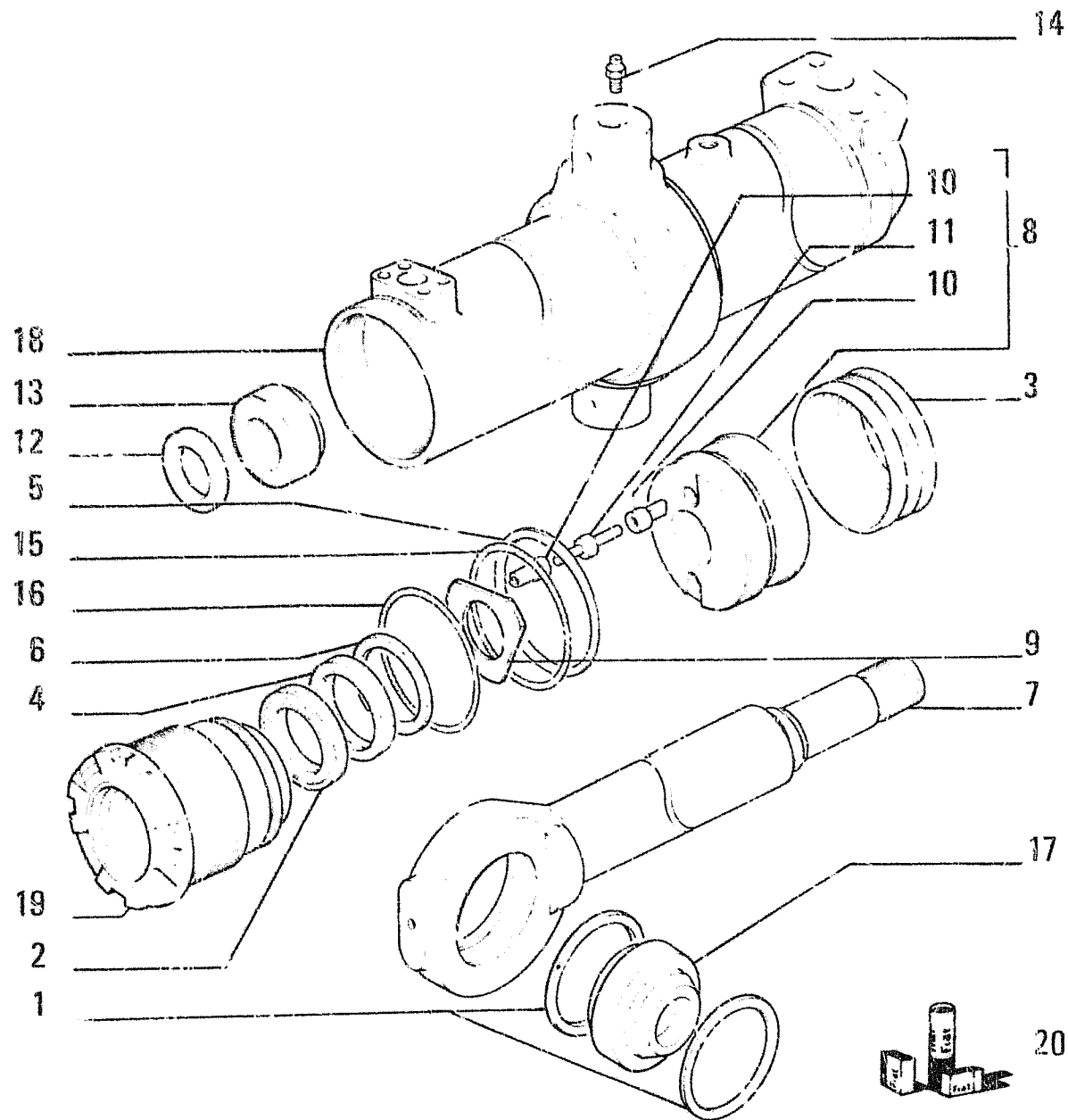

ITEM	PART NUMBER	QTY	TRANS CODE	DESCRIPTION	DESCRIZIONE
19	79092235	1	80F	BOTTOM PLATE - FRONT D2948	FONDELLO - ANTERIORE D2948
20	79071471	1	1K	KIT SEE PAGE 9 D2915	KIT VED. PAG.9 D2915

79039427-79047903-76016701
 CYLINDER - CILINDRO - CYLINDRE - ZYLINDER - CILINDRO

1

E3.32

N.T.R. 191 - 20.02.1990

604.01.081.04

R14

VPS

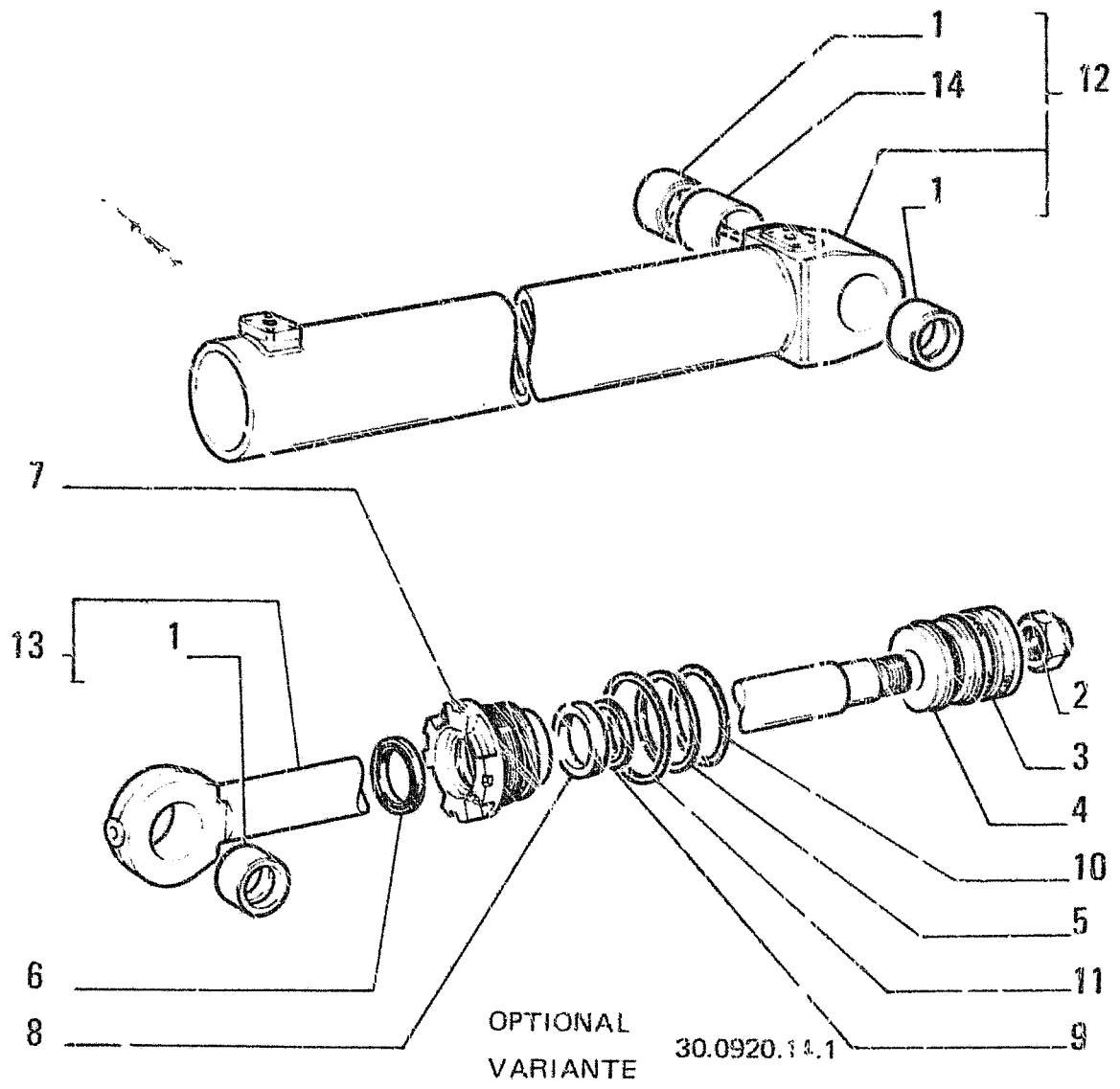

ITEM	PART NUMBER	QTY	TRANS CODE	DESCRIPTION	DESCRIZIONE
1	8280391	3	65B	BUSHING	BOCCOLA
2	8281824	1	10D	NUT	DADO
3	8291505	1	158G	O-RING	GUARNIZIONE O-R
4	8298052	1	23SS	PISTON	STANTUFFO
5	8298055	1	45A	RING	ANELLO
6	8299740	1	42A	MUDSCRAPER RING	ANELLO RASCHIAFANGO
7	8299752	1	80F	BOTTOM PLATE - FRONT	FONDELLO - ANTERIORE
8	8299754	1	158G	O-RING	GUARNIZIONE O-R
9	8299755	1	45A	RING	ANELLO
10	14466080	1	158G	O-RING 3,53x101,79	GUARNIZIONE O-R 3,53x101,79
11	14466380	1	158G	O-RING 3,53x110,72	GUARNIZIONE O-R 3,53x110,72
12	79023531	1	52C	TUBE - ASSEMBLY	CANNA CILINDRO - COMPLETO
13	79023535	1	274S	ROD - ASSEMBLY	STELO - COMPLETO
14	79023536	1	75D	SPACER	DISTANZIALE

79023529
 CYLINDER - CILINDRO - CYLINDRE - ZYLINDER - CILINDRO

ES.32/1

R15

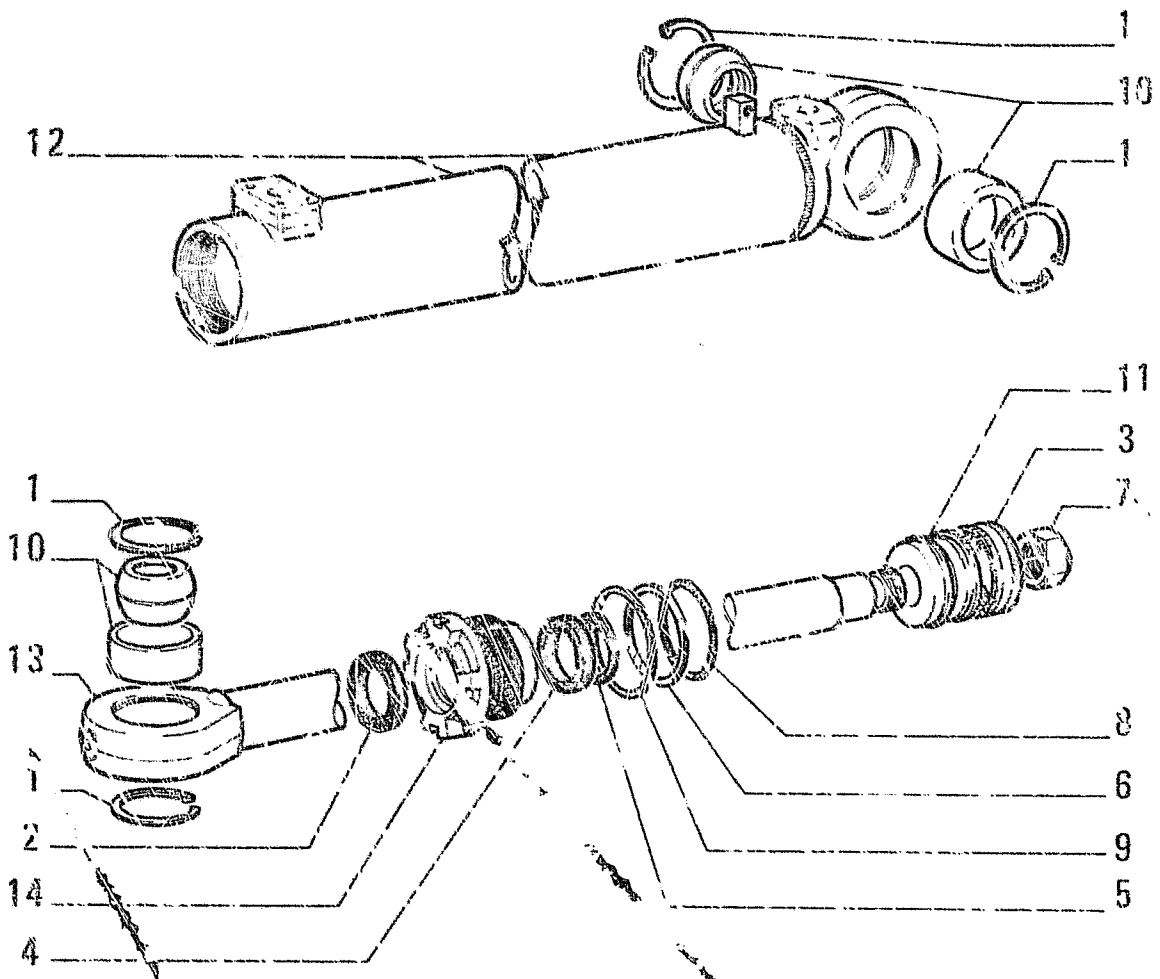

OPTIONAL 30.1030.02.1 - 30.0127.02.1
 VARIANTE

ITEM	PART NUMBER	QTY	TRANS CODE	DESCRIPTION	DESCRIZIONE
1	8280835	1	51A	LOCKRING	ANELLO DI SICUREZZA
2	8288832	1	158G	O-RING	GUARNIZIONE O-R
3	8291561	1	158G	O-RING	GUARNIZIONE O-R
4	8297073	1	158G	O-RING	GUARNIZIONE O-R
5	8297074	1	45A	RING	ANELLO
6	8297075	1	45A	RING	ANELLO
7	8298615	1	100	NUT	DADO
8	14465480	1	158G	O-RING 3,53x82,14	GUARNIZIONE O-R 3,53x82,14
9	14465780	1	158G	O-RING 3,53x91,67	GUARNIZIONE O-R 3,53x91,67
10	79036604	2	341C	BEARING	CUSCINETTO
11	79038228	1	236S	PISTON	STANTUFFO
12	79039487	1	530	TUBE	CANNA CILINDRO
13	79039492	1	274S	ROD	STELO
14	79038227	1	80F	BOTTOM PLATE - FRONT C1612	FONDELLO - ANTERIORE C1612
	79047724	1	80F	BOTTOM PLATE - FRONT D1612	FONDELLO - ANTERIORE D1612

79039486 - 79047905

CYLINDER - CILINDRO - CYLINDRE - ZYLINDER - CILINDRO

E3.32/2

R16

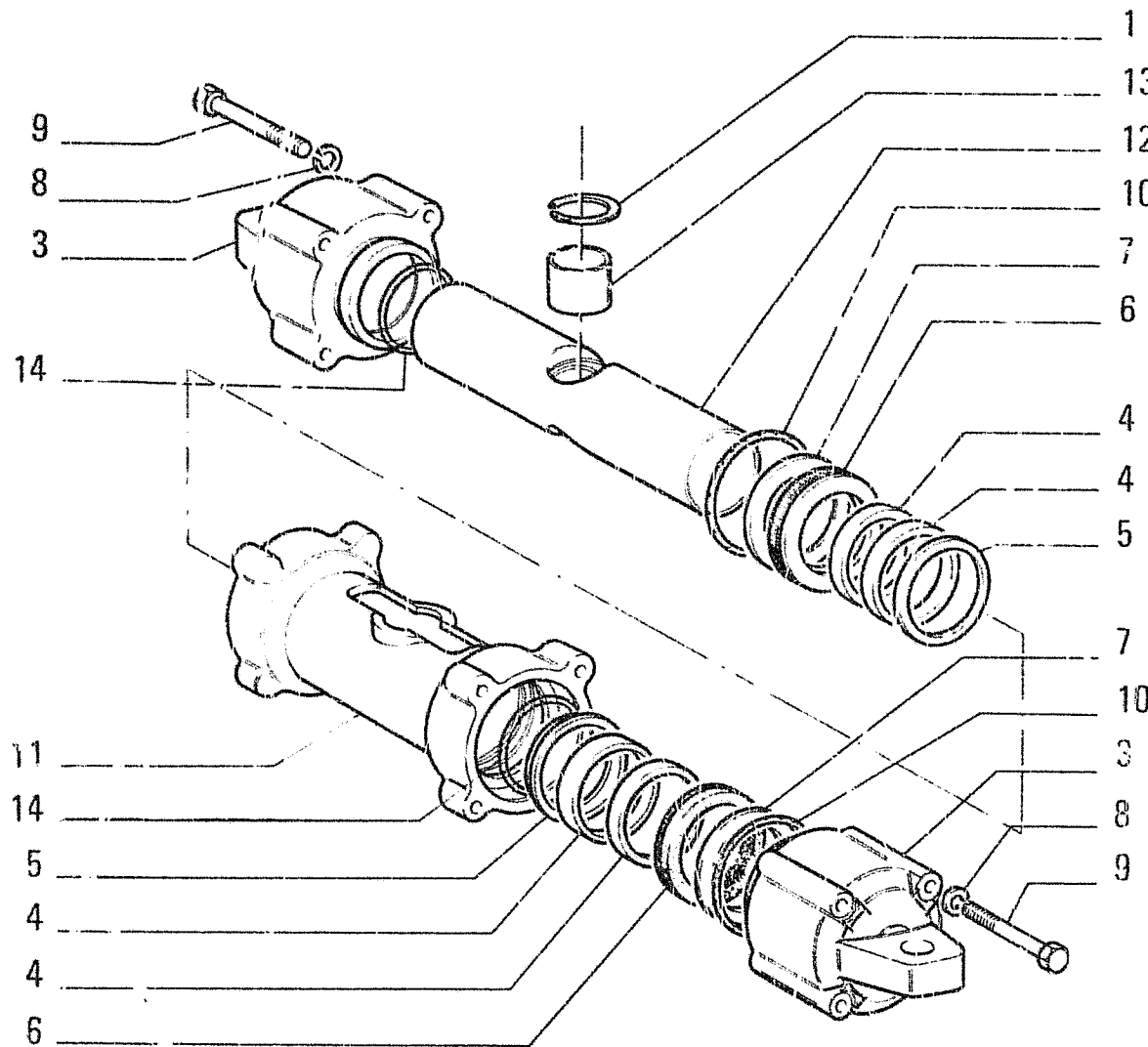

OPTIONAL
VARIANTE 30.1065.01.1 - 30.0127.02.1

ITEM	PART NUMBER	QTY	TRANS CODE	DESCRIPTION	DESCRIZIONE
1	8280835	1	57A	LOCKRING	ANELLO DI SICUREZZA
3	8298596	2	80F	BOTTOM PLATE - FRONT C2872	FONDELLO - ANTERIORE C2872
	79099277	2	80F	BOTTOM PLATE - FRONT D2872	FONDELLO - ANTERIORE D2872
4	8298599	4	45A	RING C3266	ANELLO C3266
	76016276	4	45A	RING D3266	ANELLO D3266
5	8298600	2	42A	MUDSCRAPER RING	ANELLO RASC-HIAFANGO
6	8298601	2	158G	O-RING	GUARNIZIONE O-R
7	8298602	2	75F	SPACER	DISTANZIALE
8	10517171	8	132H	LOCKWASHER 14,2x3,5	ROSETTA DI SICUREZZA 14,2x3,5
9	11117831	8	4JV	SCREW 14x2x130	VITE 14x2x130
10	14466580	2	158G	O-RING 3,53x117,07 D2872	GUARNIZIONE O-R 3,53x117,07 D2872
	14466680	2	158G	O-RING 3,53x126,59 C2872	GUARNIZIONE O-R 3,53x126,59 C2872
11	79029964	1	53C	TUBE C2872	CANNA CILINDRO C2872
	79099278	1	53C	TUBE D2872	CANNA CILINDRO D2872
12	79029965	1	274S	ROD	STELO
13	79031845	1	95B	BUSHING	BOCCOLA
14	79099276	2	45A	RING D2872	ANELLO D2872

79029963 - 79099275

CYLINDER - CILINDRO - CYLINDRE - ZYLINDER - CILINDRO

E3.32/3

N.T. 200 15.10.1990

604.01.081.05

R17

E	AUXILIARY ATTACHMENT (AND EQUIPMENT) • ORGANI SUSSIDIARI (E ATTREZZI) • ORGANES AUXILIAIRES (ET EQUIPEMENT) • MESEN AGGREGATE (AND GERÄTE) • GRUPOS AUXILIARES Y EQUIPO
---	--

E	ELECTRICAL SYSTEM • IMPIANTO ELETTRICO • SYSTEME ELECTRIQUE • ELEKTRISCHE ANLAGE • SISTEMA ELÉCTRICO
---	--

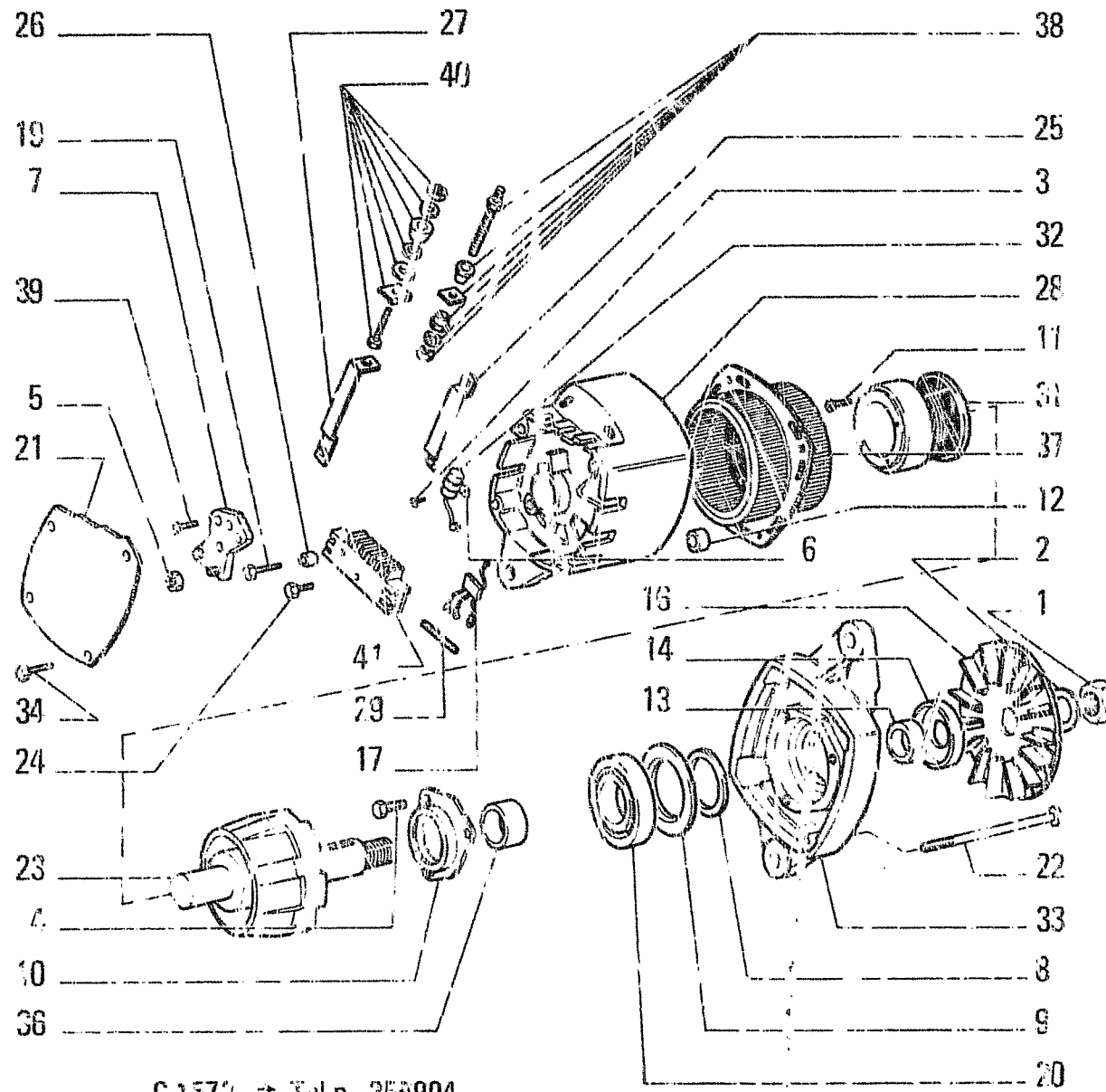

ITEM	PART NUMBER	QTY	TRANS CODE	DESCRIPTION	DESCRIZIONE
1	70189001	1	10D	NUT	DADO
2	70189002	1	131R	WASHER	ROSETTA
3	73117031	3	40V	SCREW	VITE
4	73117032	3	40V	SCREW	VITE
5	73117036	4	10D	NUT	DADO
6	73117038	1	223S	BRACKET	STAFFA
7	73117044	1	32R	RECTIFIER	RADDOLZIZZORE
8	73117056	1	131R	WASHER	ROSETTA
9	73117058	1	45A	RING	ANELLO
10	73117073	1	105P	PLATE	PIASTRA
11	73117087	4	40V	SCREW	VITE
12	73117088	1	95B	BUSHING	BCCCOLA
13	73117096	1	95B	BUSHING	BOCCOLA
14	73117103	1	334C	DUST BOOT	CUFFIA FARAPOLVERE
16	73117119	1	3EY	BLOWER	VENTOLA
17	73117126	1	53D	DIODE	DIODO
19	73117731	1	40V	SCREW	VITE
20	73133823	1	341C	BEARING	CUSCINETTO
21	73117733	1	265C	COVER	COPERCHIO
22	73117734	4	40V	SCREW	VITE
23	73117735	1	145R	ROTOR	ROTORE
24	73117737	2	40V	SCREW	VITE
25	73117739	1	235C	CONNECTION	CONNESSIONE
26	73117740	1	95B	BUSHING	BOCCOLA
27	73117741	1	235C	CONNECTION	CONNESSIONE
28	73117742	1	300S	SUPPORT	SUPPORTO
29	73117744	1	85I	INSULATOR	ISOLANTE

C1572 → Tel.n. 258904

73119134

ALTERNATOR - ALTERNATORE - ALTERNATEUR - DREHSTROM - LICHT - MASCHINE - ALTERNADOR

F3.03

M.T.R. 158 - 13.03.1937

604.C1.081.03

S2

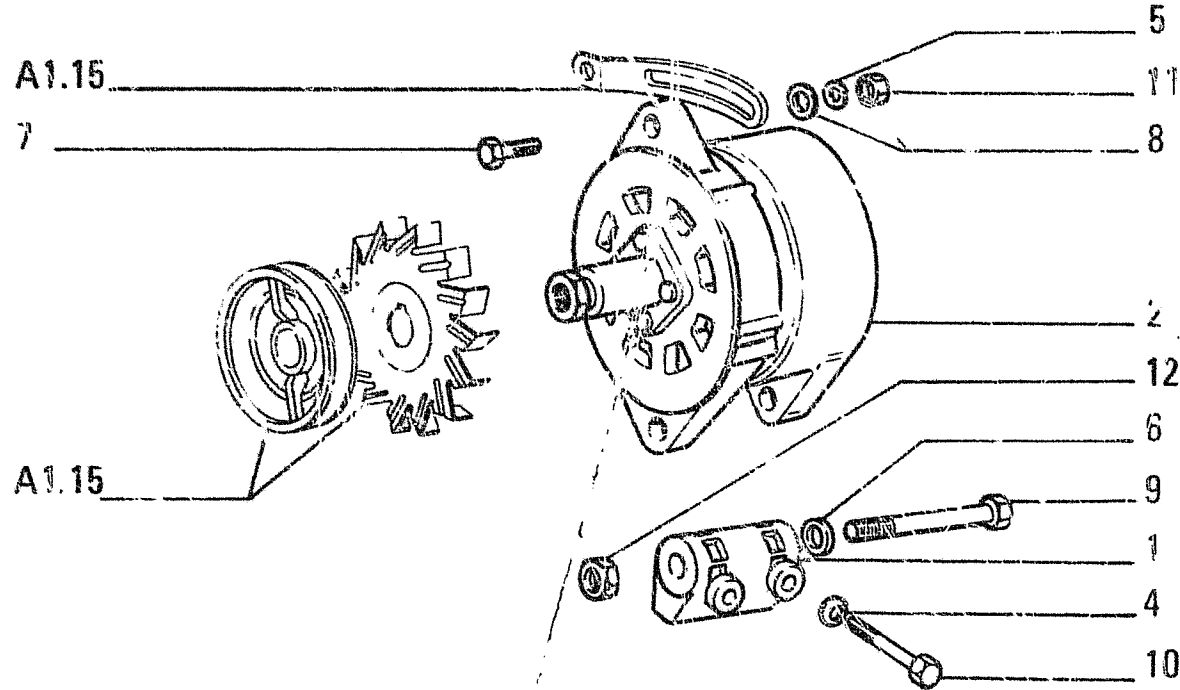

ITEM	PART NUMBER	QTY	TRANS CODE	DESCRIPTION	DESCRIZIONE
1	4600128	1	300S	SUPPORT	SUPPORTO
2	4757193	1	25A	ALTERNATOR - ASSEMBLY VED.SGR.F3.03/1A 03447	ALTERNATORE - COMPLETO VED.SGR.F3.03/1A 03447
		1	25A	ALTERNATOR - ASSEMBLY SEE SGR. F3.03/1 03447	ALTERNATORE - COMPLETO VEDERE SGR. F3.03/1 03447
	4808519	1	25A	ALTERNATOR - ASSEMBLY SEE SGR. F3.03/A 03447	ALTERNATORE - COMPLETO VEDERE SGR. F3.03/A 03447
4	11193879	2	132R	LOCKWASHER 8,4x16	ROSETTA DI SICUREZZA 8,4x16
5	11190579	1	132R	LOCKWASHER	ROSETTA DI SICUREZZA
6	11198679	1	132R	LOCKWASHER 13x24	ROSETTA DI SICUREZZA 13x24
7	15973924	1	40V	SCREW 10x1,25x35	VITE 10x1,25x35
8	12646301	1	131R	WASHER 10,2x25	ROSETTA 10,2x25
9	15541824	1	40V	SCREW	VITE
10	16044224	2	40V	SCREW	VITE
11	12164711	1	10D	NUT 10x1,25x8	DADO 10x1,25x8
12	16101511	1	10D	NUT 12x1,25x10	DADO 12x1,25x10

D 1572 Tel. n. 250905 →

CURRENT GENERATING SYSTEM - GENERAZIONE DI CORRENTE - GROUPE GENERATEUR DE COURANT -
STROMERZEUGUNG - GENERADOR DE CORRIENTE

F3.01

2A

N.T.R. 205 - 30.09.1991
004.01.001.06

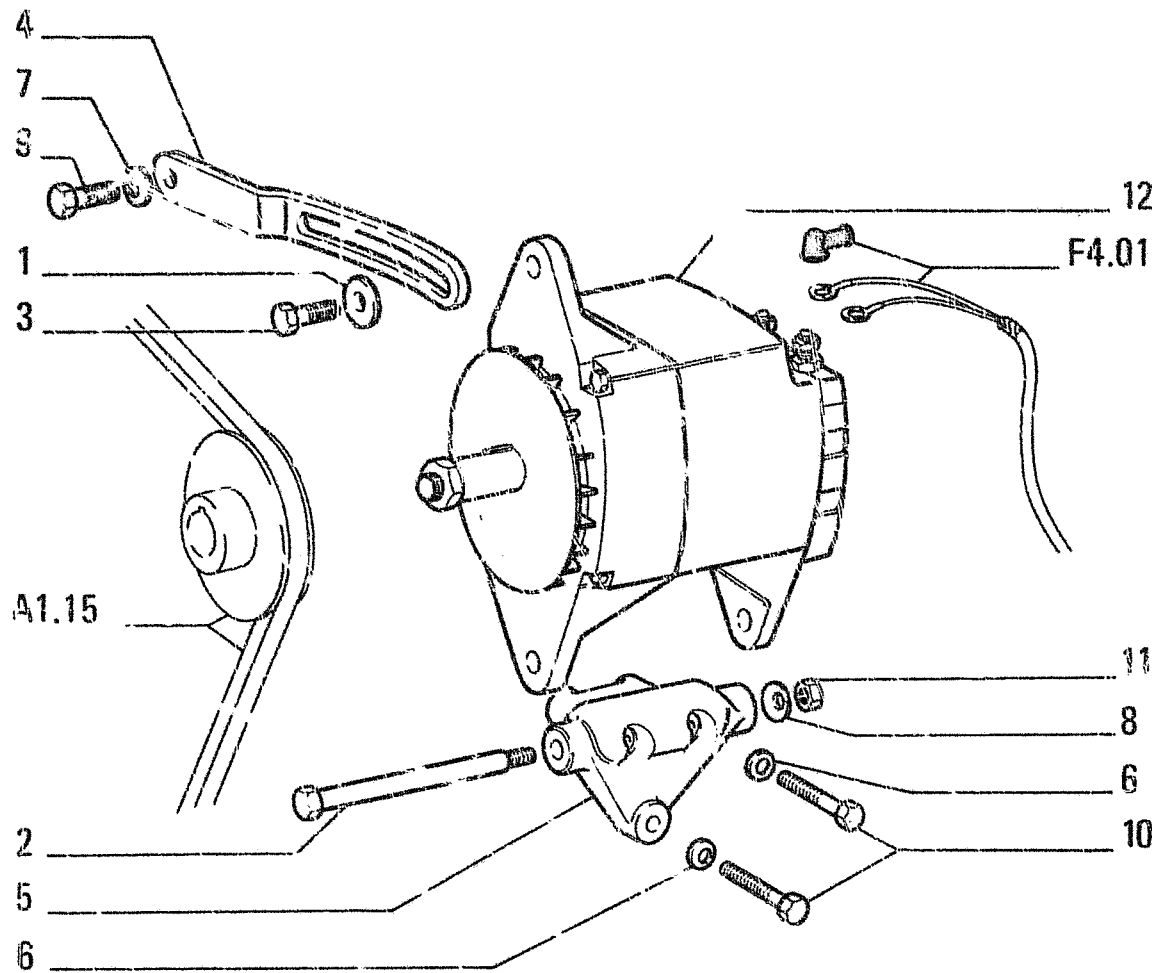

C 1572 → Tel.n. 250904

ITEM	PART NUMBER	QTY	TRANS CODE	DESCRIPTION	DESCRIZIONE
1	4643544	1	131R	WASHER	ROSETTA
2	4744740	1	40V	SCREW	VITE
3	4744741	1	40V	SCREW	VITE
4	4744845	1	87T	BELT STRETCHER	TENDICINGHIA
5	A1756657	1	300S	SUPPORT	SUPPORTO
6	11198871	3	132R	LOCKWASHER 8,4x16	ROSETTA DI SICUREZZA 8,4x16
7	11198871	1	132R	LOCKWASHER 16,5x20	ROSETTA DI SICUREZZA 10,5x20
8	11198671	1	132R	LOCKWASHER 13x24	ROSETTA DI SICUREZZA 13x24
9	15970921	1	40V	SCREW 10x1,25x35	VITE 10x1,25x35
10	16044121	3	40V	SCREW 8x1,25x45	VITE 8x1,25x45
11	16101511	1	10D	NUT 12x1,25x10	DADO 12x1,25x10
12	73119134	1	25A	ALTERNATOR - ASSEMBLY SEE SGR. F3.03	ALTERNATORE - COMPLETO VEDERE SGR. F3.03

CURRENT GENERATING SYSTEM — GENERAZIONE DI CORRENTE — GROUPE GENERATEUR DE
 COURANT — STROMERZEUGUNG — GENERADOR DE CORRIENTE

F3.01

2

N.T.R. 158 - 13.03.1987

604.01.081.03

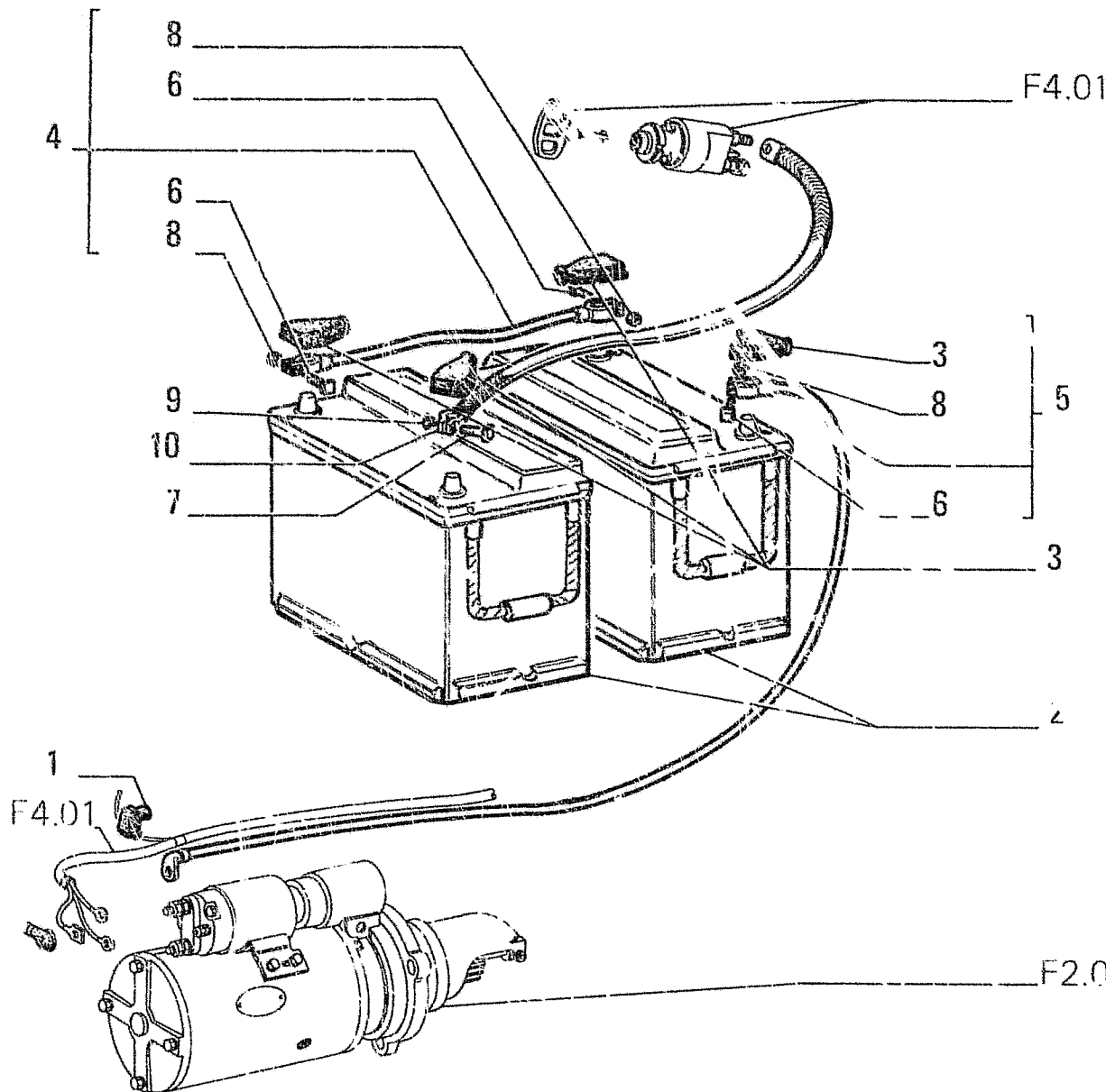

ITEM	PART NUMBER	QTY	TRANS CODE	DESCRIPTION	DESCRIZIONE
1	552099	1	65C BOOT	C2953	CAPPUCCIO C2953
2	4360103	2	25B BATTERY	C1576	BATTERIA C1576
	7906250	2	25B BATTERY	D1576	BATTERIA D1576
3	4950255	3	65C BOOT		CAPPUCCIO
4	4954336	1	111C CABLE - ASSEMBLY		CAVO - COMPLETO
5	4995683	1	111C CABLE - ASSEMBLY	C2953	CAVO - COMPLETO C2953
	76017920	1	111C CABLE - ASSEMBLY	D2953	CAVO - COMPLETO D2953
6	11945008	3	40V SCREW	6x1x30	VITE 6x1x30
7	11947708	1	10CV SCREW	8x1,25x30	VITE 8x1,25x30
8	15896218	3	10 NUT	6x1x5	DADO 6x1x5
9	16100818	1	10L NUT	8x1,25x6,5	DADO 8x1,25x6,5
10	79035908	1	166T	GROUND BRAID	TRECCIA DI MASSA

CURRENT GENERATING SYSTEM - GENERAZIONE DI CORRENTE - G. JUPE GENERATEUR DE COURANT - STROMERZEUGUNG - GENERADOR DE CORRIENTE

F3.01 1

N.T.R. 191 - 20.02.1990

604.01.081.04

S5

20A

PARTS MARKED * ARE NOT SUPPLIED AS SPARES
 I PARTICOLARI CONTRASSEGNA TI CON * NON
 VENGONO FORNITI DI RICAMBIO

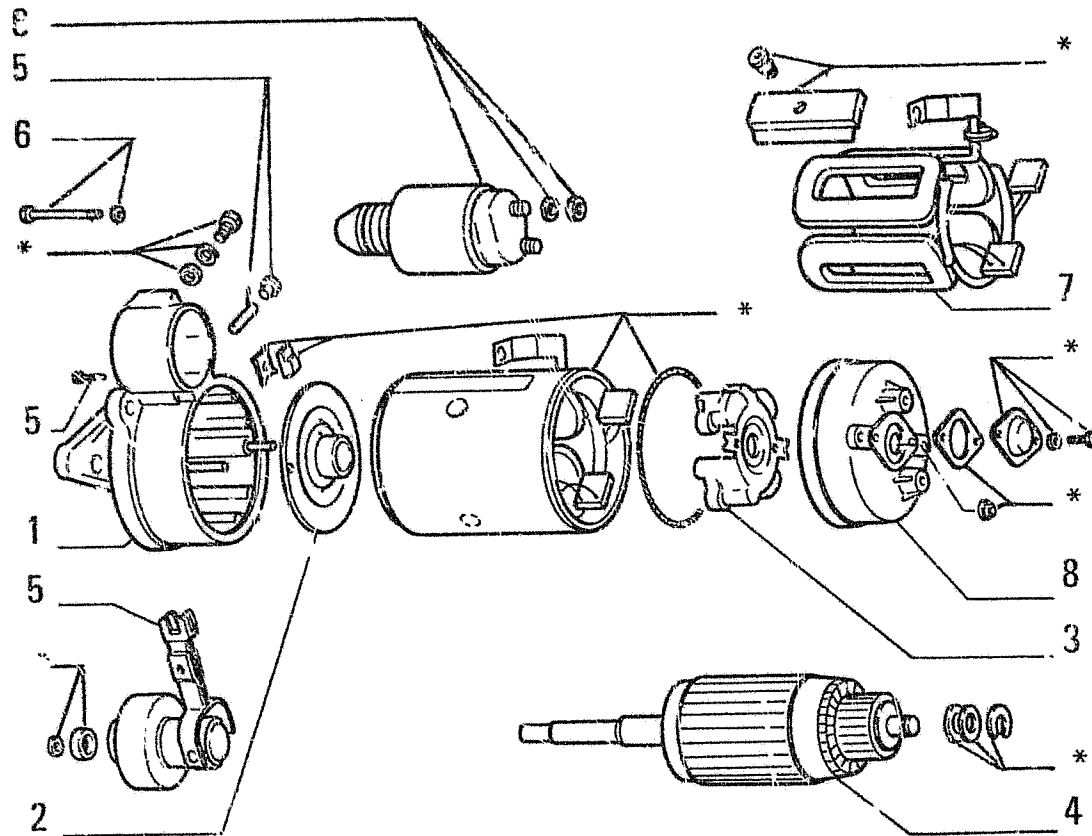

I T E M	PART NUMBER	Q T Y	TRANS CODE	DESCRIPTION	DESCRIZIONE
1	79081044	1	300S	SUPPORT	SUPPORTO
2	9927795	1	300S	SUPPORT	SUPPORTO
3	79080376	1	197P	BRUSH HOLDER	PORTASPAZZOLA
4	79080373	1	40I	ARMATURE	INDOTTO
5	79081045	1	2K	KIT	KIT
6	79081046	1	2K	KIT	KIT
7	79080375	1	83B	COIL	BOBINA
8	79081047	1	265C	COVER	COPERCHIO

D 1572 Tel. n. 250905 →



4807379

STARTERMOTOR - MOTORINO DI AVVIAMENTO - DEMARREUR - ANLASSER - MOTOR DE ARRANQUE

F2.05/A

N.T.R. 200 - 15.10.1990

604.01.081.05

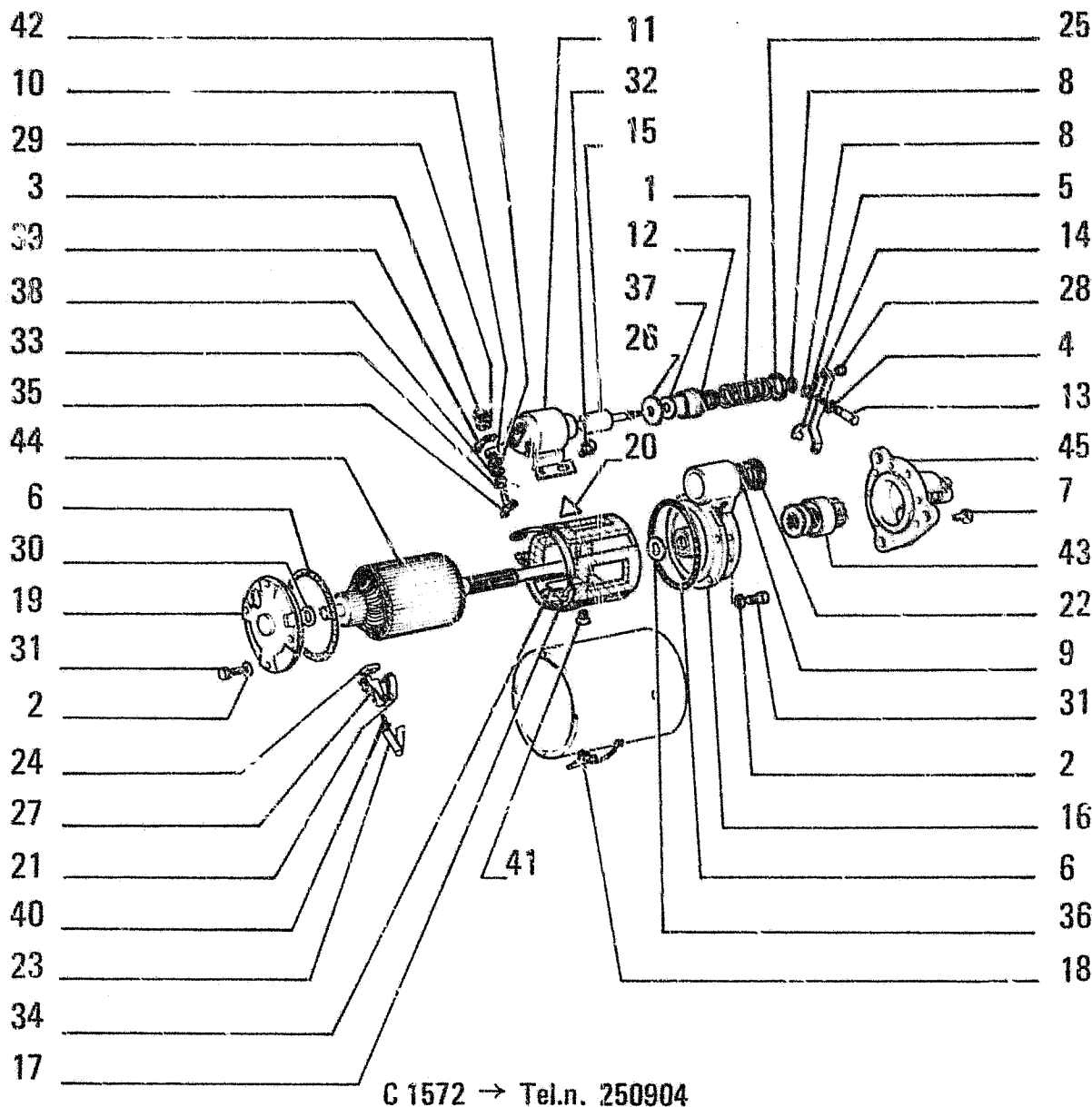

C 1572 → Tel.n. 250904

FIATALLIS FD7

ITEM	PART NUMBER	QTY	TRANS CODE	DESCRIPTION	DESCRIZIONE
28	73116952	1	10D	NUT	DADO
29	73116955	1	10D	NUT	DADO
30	73116951	4	131R	WASHER	ROSETTA
31	73116962	9	40V	SCREW	VITE
32	73116966	4	40V	SCREW	VITE
33	73116967	1	145B	GUIDE BUSHING	BUSSOLA
34	73116968	4	110P	PLAQUE	PIASTRINA
35	73116969	1	40V	SCREW	VITE
36	73116973	1	131R	WASHER	ROSETTA
37	73116978	1	131R	WASHER	ROSETTA
38	73116979	1	131R	WASHER	ROSETTA
39	73116981	1	75B	CONNECTOR	BLOCCHETTO CONNESSIONE
40	73116983	4	44V	SCREW AND WASHER ASSY	VITE CON ROSETTA
41	73116986	4	40V	SCREW	VITE
42	73117147	1	131R	WASHER	ROSETTA
43	73119703	1	65I	DRIVE	INNESTO
44	73125149	1	40I	ARMATURE	INDOTTO
45	73130213	1	300S	SUPPORT	SUPPORTO

73124564

STARTER MOTOR - MOTORINO DI AVVIAMENTO - DEMARREUR - ANLASSER - MOTOR DE ARRANQUE

F2.05

N.T.R. 158 - 13.03.1987

604.01.081.03

S7

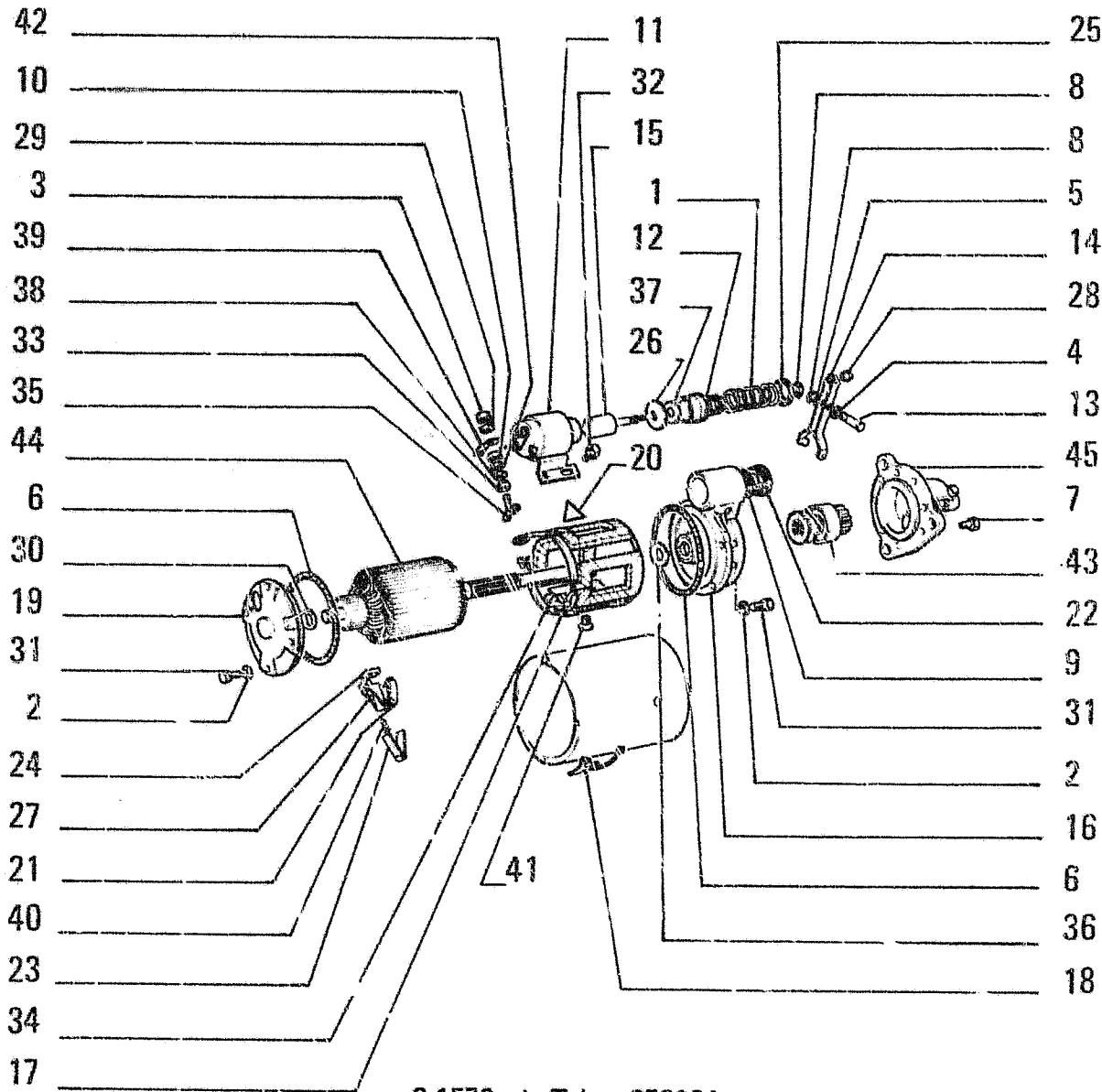

C 1572 → Tel.n. 250904

FIATALLIS FD7

F2.05 TAV. 1 PAG.1

ITEM	PART NUMBER	QTY	TRANS CODE	DESCRIPTION	DESCRIZIONE
1	70649665	1	100M	SPRING	MOLLA
2	70916964	9	132R	LOCKWASHER	ROSETTA DI SICUREZZA
3	70916965	9	132R	LOCKWASHER	ROSETTA DI SICUREZZA
4	70923558	1	158G	O-RING	GUARNIZIONE O-R
5	70923560	1	158G	O-RING	GUARNIZIONE O-R
6	70923588	2	158G	O-RING	GUARNIZIONE O-R
7	70926353	6	50T	PLUG	TAPPO
8	70927726	2	45A	RING	ANELLO
9	70930278	1	158G	O-RING	GUARNIZIONE O-R
10	70933816	3	10D	NUT	DADO
11	73116822	1	75I	SWITCH	INTERRUTTORE
12	73116823	1	65C	BOOT	CAPPUCCIO
13	73116833	1	100M	SPRING	MOLLA
14	73116834	1	45L	LEVER	LEVA
15	73116836	1	60N	CORE	NUCLEO
16	73116839	1	300S	SUPPORT	SUPPORTO
17	73116848	1	83B	COIL	BOBINA
18	73116849	1	300S	SUPPORT	SUPPORTO
19	73116851	1	265C	COVER	COPERCHIO
20	73116859	2	85I	INSULATOR	ISOLANTE
21	73116868	2	197P	BRUSH HOLDER	PORTASPAZZOLA
22	73116869	1	50T	PLUG	TAPPO
23	73116876	4	100M	SPRING	MOLLA
24	73116880	4	177S	BRUSH	SPAZZOLA
25	73116888	1	131R	WASHER	ROSETTA
26	73116890	1	131R	WASHER	ROSETTA
27	73116893	2	197P	BRUSH HGLDR	PORTASPAZZOLA

73124564

STARTER MOTOR - MOTORINO DI AVVIAMENTO - DEMARREUR - ANLASSER - MOTOR DE ARRANQUE

F2 05

N.T.R. 158 - 13.03.1987

604.01.081.03

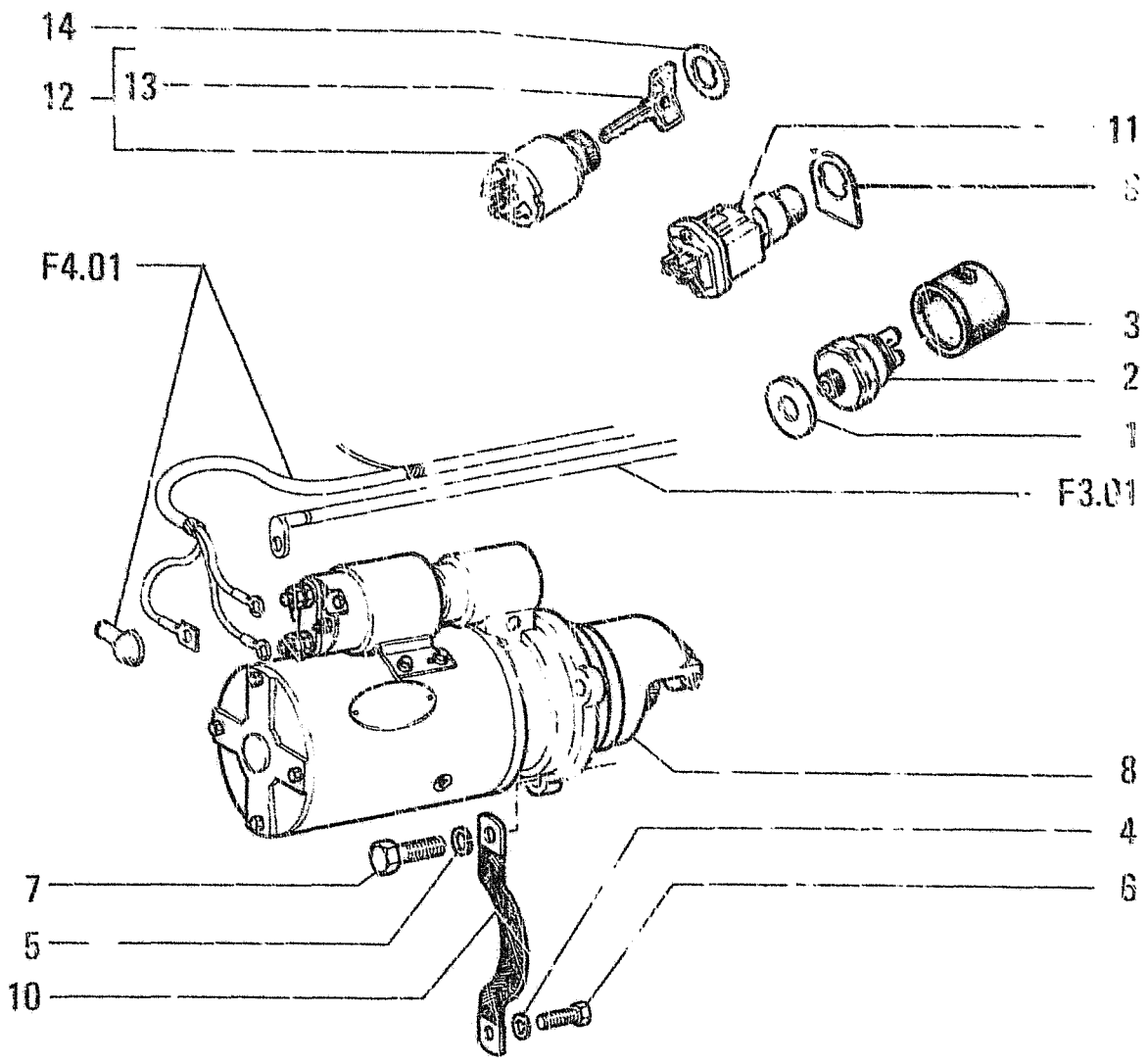

ITEM	PART NUMBER	QTY	TRANS CODE	DESCRIPTION	DESCRIZIONE
1	595208		131R	WASHER	ROSETTA
2	4073976	1	75I	SWITCH	INTERRUTTORE
3	4073977	1	66C	BOOT	CAPPUCCIO
4	10516871	1	132R	LOCKWASHER 10x2,5	ROSETTA DI SICUREZZA 10x2,5
5	10520121	3	131R	WASHER 14,4x26 C1572	ROSETTA 14,4x26 C1572
6	1190579	3	131R	WASHER D1572	ROSETTA D1572
7	10579931	1	40V	SCREW 10x1,5x14	VITE 10x1,5x14
8	11300924	3	40V	SCREW 10x1,25x30 D1572	VITE 10x1,25x30 D1572
9	11408301	3	40V	SCREW 14x1,5x35 C1572	VITE 14x1,5x35 C1572
10	4607379	1	133M	STARTER MOTOR - ASSEMBLY SEE SGR F2.05/A D1572	MOTORINO AVVIAMENTO - COMPLETO VEDERE SGR F2.05/A D1572
11	73124504	1	133M	STARTER MOTOR - ASSEMBLY SEE SGR F2.05 C1572	MOTORINO AVVIAMENTO - COMPLETO VEDERE SGR F2.05 C1572
12	79019490	1	65T	DELTA C1510	TARGA C1510
13	79020354	1	166T	GROUND BRAID	TRECCIA DI MASSA
14	79027131	1	236P	PUSH BUTTON C1510	PULSANTE C1510
15	79057500	1	210C	SWITCH - ASSEMBLY D1510	COMMUTATORE - COMPLETO D1510
16	79079957	2	150C	KEY D1510	CHIAVE D1510
17	79057502	1	45A	RING D1510	ANELLO D1510

ENGINE STARTING EQUIPMENT - AVVIAMENTO MOTORE - LANCEMENT DU MOTEUR - ANLASSEN DES MOTORS - ARRANQUE DEL MOTOR

F2.01
N.T.R. 158 - 13.03.1967
604.01.081.03

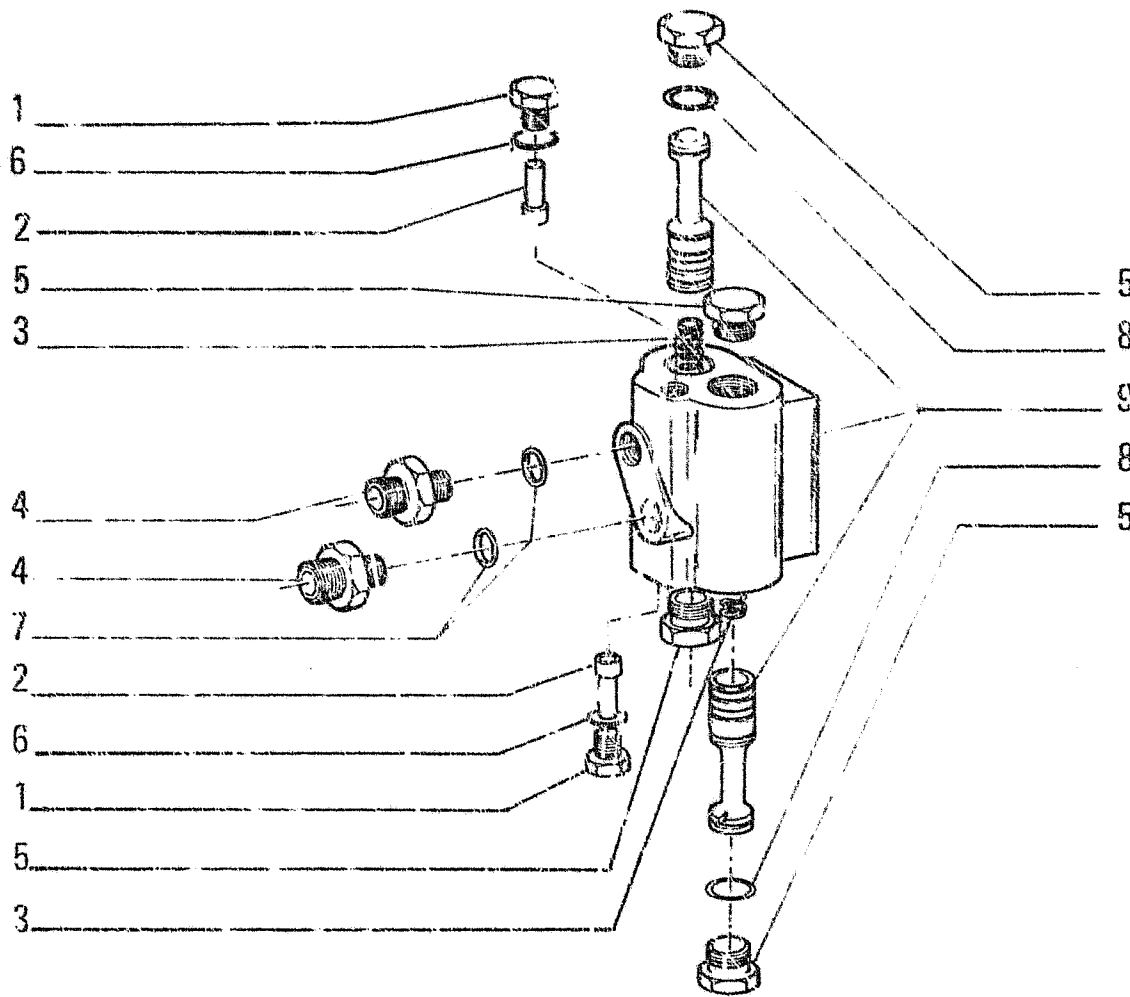

QTY	PART NUMBER	TRANS CODE	DESCRIPTION	DESCRIZIONE
1	8281744	2	50T PLUG	TAPPO
2	8298364	2	19V PAN	VASCHETTA
3	8298365	2	100M SPRING	MOLLA
4	8298366	2	2CR FITTING	RACCORDO
5	8298367	4	50T PLUG	TAPPO
6	14452980	2	158G O-RING 1,78x9,25	GUARNIZIONE O-R 1,78x9,25
7	14456980	2	158G O-RING 2,62x10,77	GUARNIZIONE O-R 2,62x10,77
8	14457380	4	158G O-RING 2,62x17,12	GUARNIZIONE O-R 2,62x17,12
9	79035111	1	300C BODY	CORPO

C 1159 → tel. n. 250235

79035109
 VALVE - VALVOLA - SOUPAPE - VENTIL - VALVOLA

E3.34

N.T.N. 200 - 15.10.1990

604.01.081.05

S10

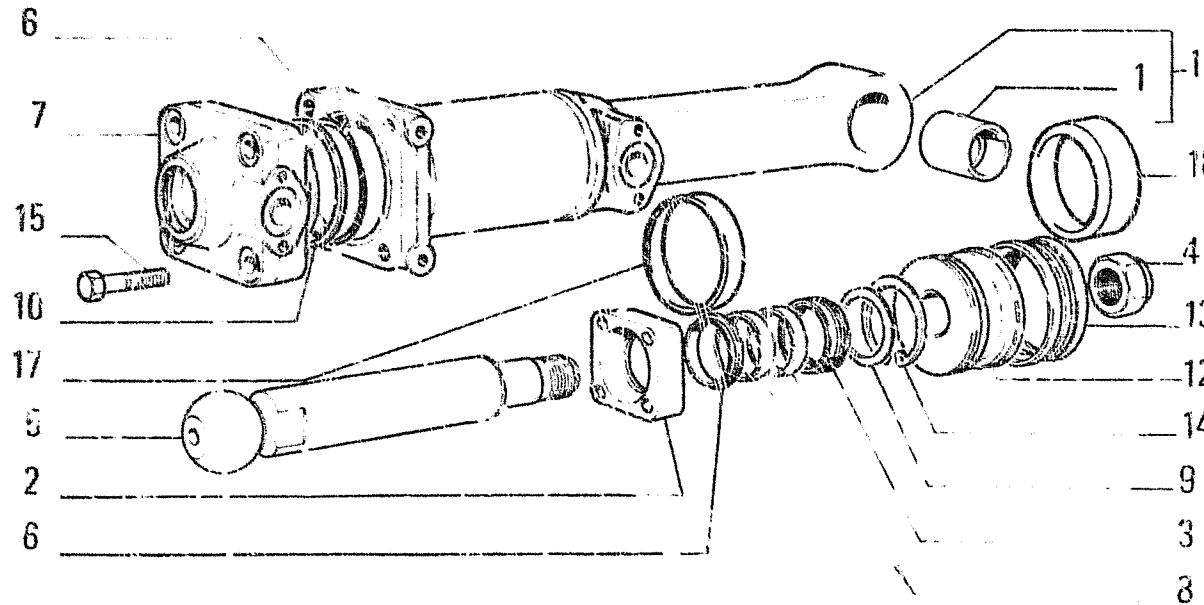

OPTIONAL
VARIANTE 30.0405.02.1

ITEM	PART NUMBER	QTY	TRANS CODE	DESCRIPTION	DESCRIZIONE
1	8283007	1	95B	BUSHING	BOCCOLA
2	8283053	1	75S	BALL SOCKET	SEDE SFERICA
3	8286438	1	158G	O-RING	GUARNIZIONE O-R
4	8287193	1	10D	NUT	DAVO
5	8288803	1	274S	ROD	STELO
6	8288804	1	42A	MUDSCRAPER RING	ANELLO RASCHIAFANGO
7	8288805	1	80F	BOTTOM PLATE - FRONT	FONDELLO - ANTERIORE
8	8288806	2	96B	GUIDE BUSHING	BOCCOLA DI GUIDA
9	8288807	4	75I	SPACER	DISTANZIALE
10	8288808	1	158J	O-RING	GUARNIZIONE O-R
11	8288810	1	30C	BODY - ASSEMBLY	CORPO - COMPLETO
12	8290222	1	235	PISTON	STANTUFFO
13	8291507	1	158C	O-RING	GUARNIZIONE O-R
14	11062175	1	51A	LOCKRING 90,5x3	ANELLO DI SICUREZZA 90,5x3
15	14272030	4	40I	SCREW 18x1,5x65	VITE 18x1,5x65
16	14466780	1	158E	O-RING 3,53x123,42	GUARNIZIONE O-R 3,53x123,42
17	8296794	1	75J	SPACER - FRONT	DISTANZIALE - ANTERIORE
18	8296795	1	75K	SPACER - REAR	DISTANZIALE - POSTERIORE

CYLINDER - CILINDRO - CYLINDRE - SYLINDER - CILINDRO

E3 32/8

N.T.P. 200 15.10.1960

604.01.021.05

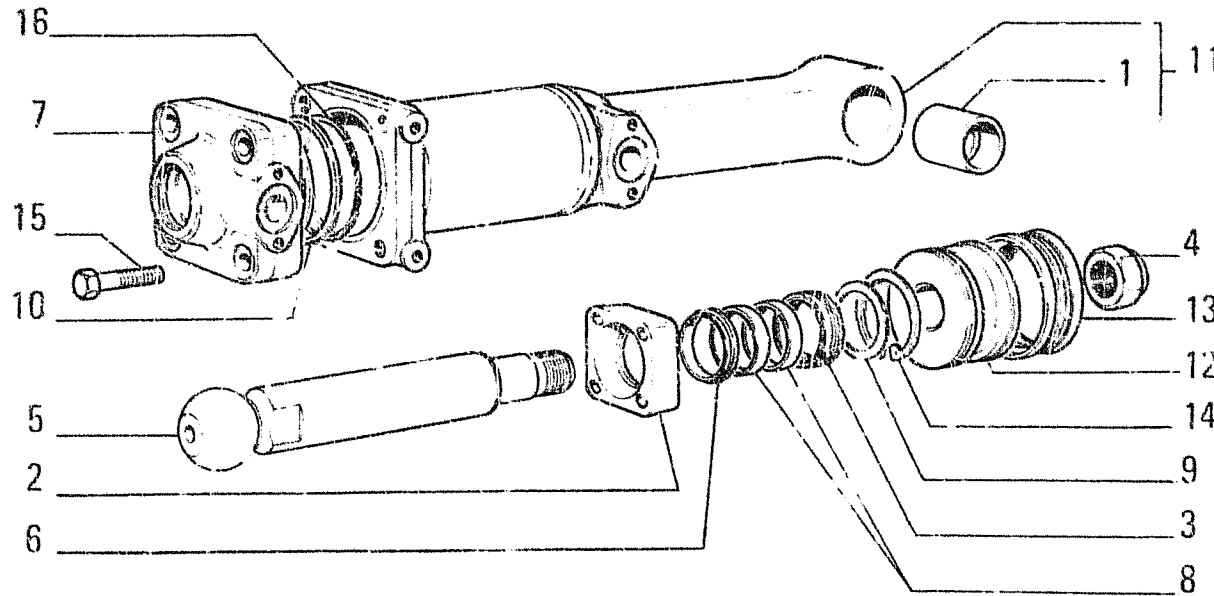

OPTIONAL
VARIANTE 0.0405.03.1

ITEM	PART NUMBER	QTY	TRANS CODE	DESCRIPTION	DESCRIZIONE
1	8283007	1	95B	BUSHING	BOCCOLA
2	8283053	1	75S	BALL SOCKET	SEDE SFERICA
3	8286438	1	158G	O-RING	GUARNIZIONE O-R
4	8287193	1	10D	NUT	DADO
5	8288803	1	274S	ROD	STELO
6	8288804	1	42A	MUDSCRAPER RING	ANELLO RASCHIAFANGO
7	8288805	1	80F	BOTTOM PLATE - FRONT	FONDILO - ANTERIORE
8	8288806	2	96B	GUIDE BUSHING	BOCCOLA DI GUIDA
9	8288807	4	75D	SPACER	DISTANZIALE
10	8288808	1	158G	O-RING	GUARNIZIONE O-R
11	8288810	1	300C	BODY - ASSEMBLY	CORPO - COMPLETO
12	8290222	1	235S	PISTON	STANTUFFO
13	8291507	1	158G	O-RING	GUARNIZIONE O-R
14	11062175	1	51A	LOCKRING 90,5x3	ANELLO DI SICUREZZA 90,5x3
15	14272030	4	40V	SCREW 18x1,5x65	VITE 18x1,5x65
16	14466780	1	158G	O-RING 3,53x123,42	GUARNIZIONE O-R 3,53x123,42

8288798
CYLINDER - CILINDRO - CYLINDRE - ZYLINDER - CILINDRO

E3.32/7

N.T.R. 191 - 20.02.1990

604.01.081 04

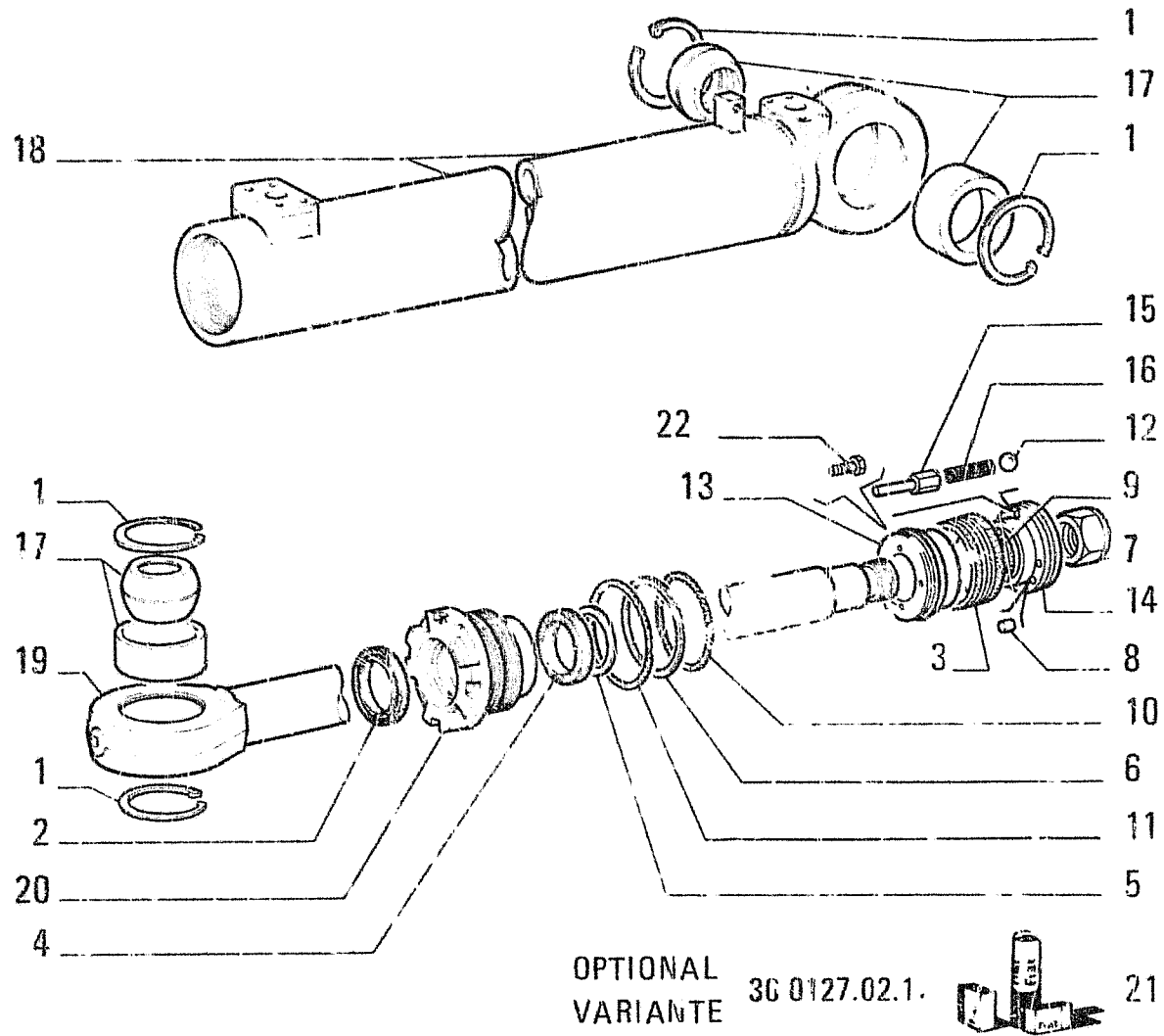

ITEM	PART NUMBER	QTY	TRANS CODE	DESCRIPTION	DESCRIZIONE
17	79037560	2	341C	BEARING - IN ALTERNATIVE	CUSCINETTO - IN ALTERNATIVA
18	79039487	1	53C	TUBE	CANNA CILINDRO
19	79039492	1	274S	ROD	STELO
20	79047724	1	80F	BOTTOM PLATE - FRONT E2948	FONDELLO - ANTERIORE C2948
	79093005	1	80F	BOTTOM PLATE - FRONT D2948	FONDELLO - ANTERIORE D2948
21	79071319	1	1K	KIT SEE PAGE 9 D2916	KIT VED. PAG 9 D2916
22	14304321	4	40V	SCREW 5x0,8x20 D2914	VITE 5x0,8x20 D2914

76014155-76015984-76016703
 CYLINDER - CILINDRO - CYLINDRE - ZYLINDER - CILINDRO

E3.32/6
 N.T.R. 191 - 20.02.1990
 604.01.081.04

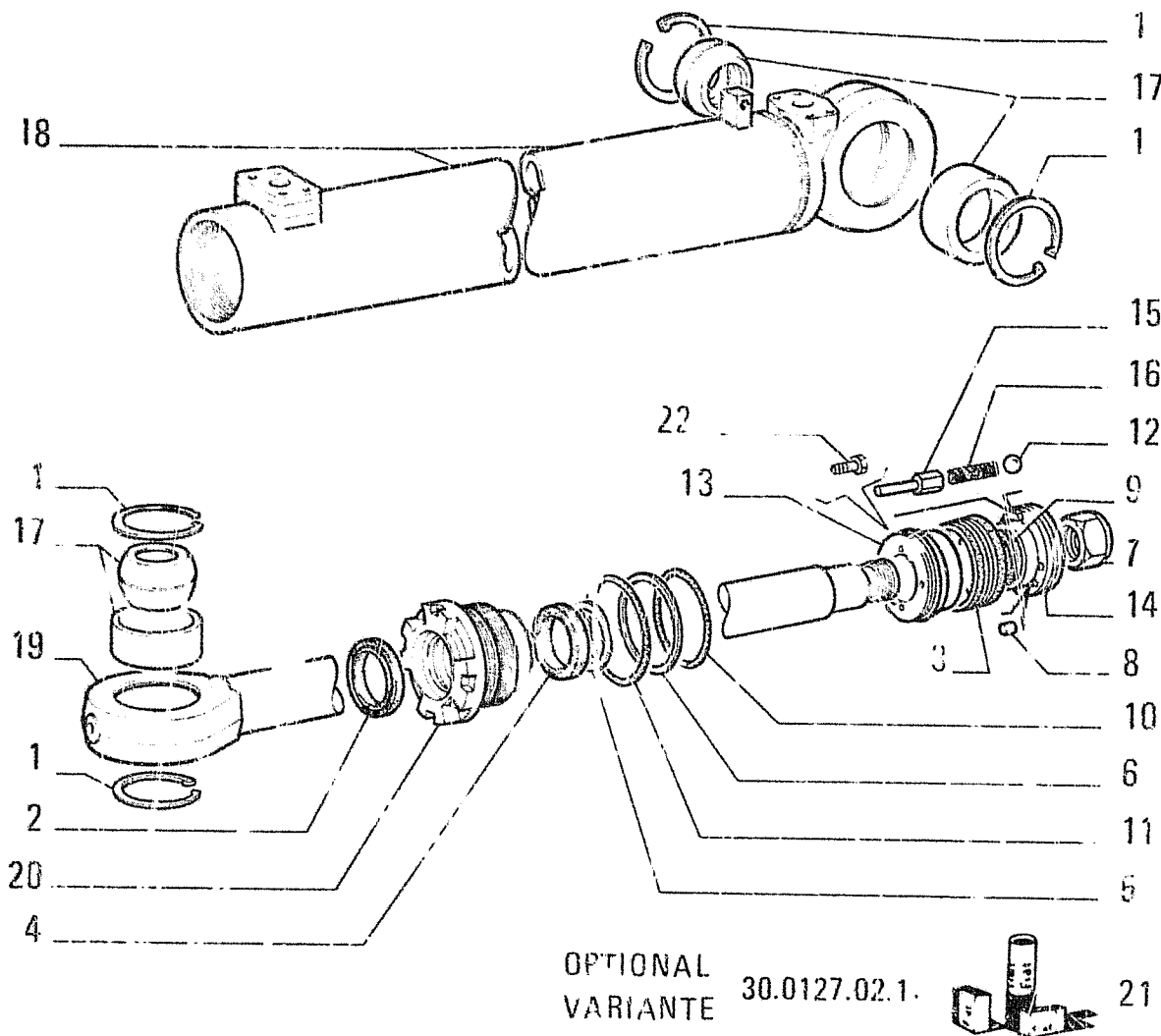

ITEM	PAR. NUMBER	QTY	TRANS CODE	DESCRIPTION	DESCRIZIONE
1	8280835	4	45A	RING	ANELLO
2	8288832	1	123G	SEAL ASSY C2916	GUARNIZIONE TENUTA FRONTALE C2916
	79065562	1	123G	SEAL ASSY D2916	GUARNIZIONE TENUTA FRONTALE D2916
3	8291561	1	120G	GASKET	GUARNIZIONE PIANA
4	8297073	1	120G	GASKET C2916	GUARNIZIONE PIANA C2916
	79065561	1	45A	RING D2916	ANELLO D2916
5	8297074	1	45A	RING C2916	ANELLO C2916
	79065560	1	120G	GASKET D2916	GUARNIZIONE PIANA D2916
6	8297075	1	45A	RING	ANELLO
7	8298615	1	10D	NUT	DADO
8	10839610	1	90G	DOWEL 8x12	GRANO 8x12
9	14458480	1	158G	O-RING 2.62x34.59 C2914	GUARNIZIONE O-R 2,62x34,59 C2914
	14463880	2	158G	O-RING 3.53x34.52 D2914	GUARNIZIONE O R 3,53x34,52 D2914
10	14465480	1	158G	O-RING 3.53x82.14	GUARNIZIONE O-R 3,53x82,14
11	14465780	1	158G	O-RING 3.53x91.67	GUARNIZIONE O-R 3,53x91,67
12	20419310	4	140S	BALL 15.082	SFERA 15,082
13	76014156	1	108S	HALF PISTON C2914	SEMISTANTUFFO C2914
	76015985	2	108S	HALF PISTON D2914	SEMISTANTUFFO D2914
14	76014157	1	108S	HALF PISTON C2914	SEMISTANTUFFO C2914
	76015986	2	108S	HALF PISTON D2914	SEMISTANTUFFO D2914
15	76014158	4	10V	VALVE	VALVOLA
16	76014159	4	100M	SPRING	MOLLA
17	79036604	2	341C	BEARING - IN ALTERNATIVE	CUSCINETTO - IN ALTERNATIVA

76014155-76015984-76016703
CYLINDER - CILINDRO - CYLINDRE ZYLINDER - CILINDRO

E3.32/6

N.T.R. 191 - 20.02.1990

604.01.081.04

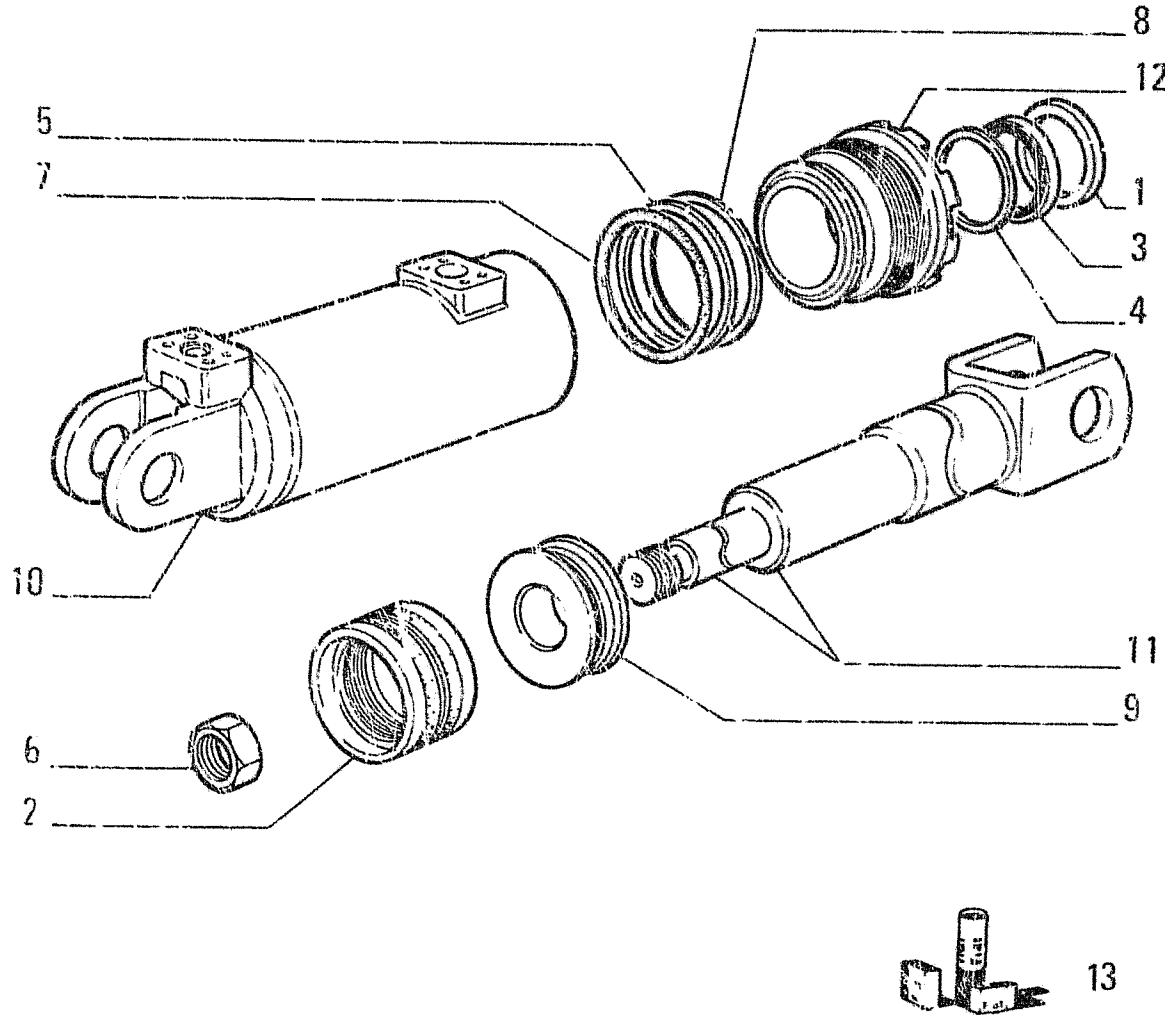

OPTIONAL
VARIANTE 30.1124.05.1

ITEM	PART NUMBER	QTY	TRANS CODE	DESCRIPTION	DESCRIZIONE
1	8288832	1	120G	GASKET C2916	GUARNIZIONE PIANA C2916
	79065562	1	122G	SEAL D2916	GUARNIZIONE D2916
2	8291561	1	121G	GASKET	GUARNIZIONE PIANA
3	8297073	1	120G	GASKET C2916	GUARNIZIONE PIANA C2916
	79065561	1	45A	RING D2916	ANELLO D2916
4	8297074	1	158G	O-RING C2916	GUARNIZIONE O-R C2916
	79065560	1	120G	GASKET D2916	GUARNIZIONE PIANA D2916
5	8297075	1	158G	O-RING	GUARNIZIONE O-R
6	8298615	1		NUT	DADO
7	14465480	1	45A	RING 3,53x82,14	ANELLO 3,53x82,14
8	14465780	1	45A	RING 3,53x91,67	ANELLO 3,53x91,67
9	79038228	1	235S	PISTON	STANTUFFO
10	79039469	1	53C	TUBE	CANNA CILINDRO
11	79039473	1	274S	ROD	STELO
12	79038227	1	80F	BOTTOM PLATE - FRONT C1612	FONDELLO - ANTERIORE C1612
	79047724	1	80F	BOTTOM PLATE - FRONT D1612	FONDELLO - ANTERIORE D1612
		1	80F	BOTTOM PLATE - FRONT C2948	FONDELLO - ANTERIORE C2948
	79093005	1	80F	BOTTOM PLATE - FRONT D2948	FONDELLO - ANTERIORE D2948
13	79071319	1	1K	KT SEE PAGE 9 D2916	KIT VED. PAG.9 D2916

79039467-79047904-76016702
CYLINDER - CILINDRO - CYLINDRE - ZYLINDER - CILINDRO

1
E3.32/5
N.T.F. 191 - 20.02.1990
604.01.081.04

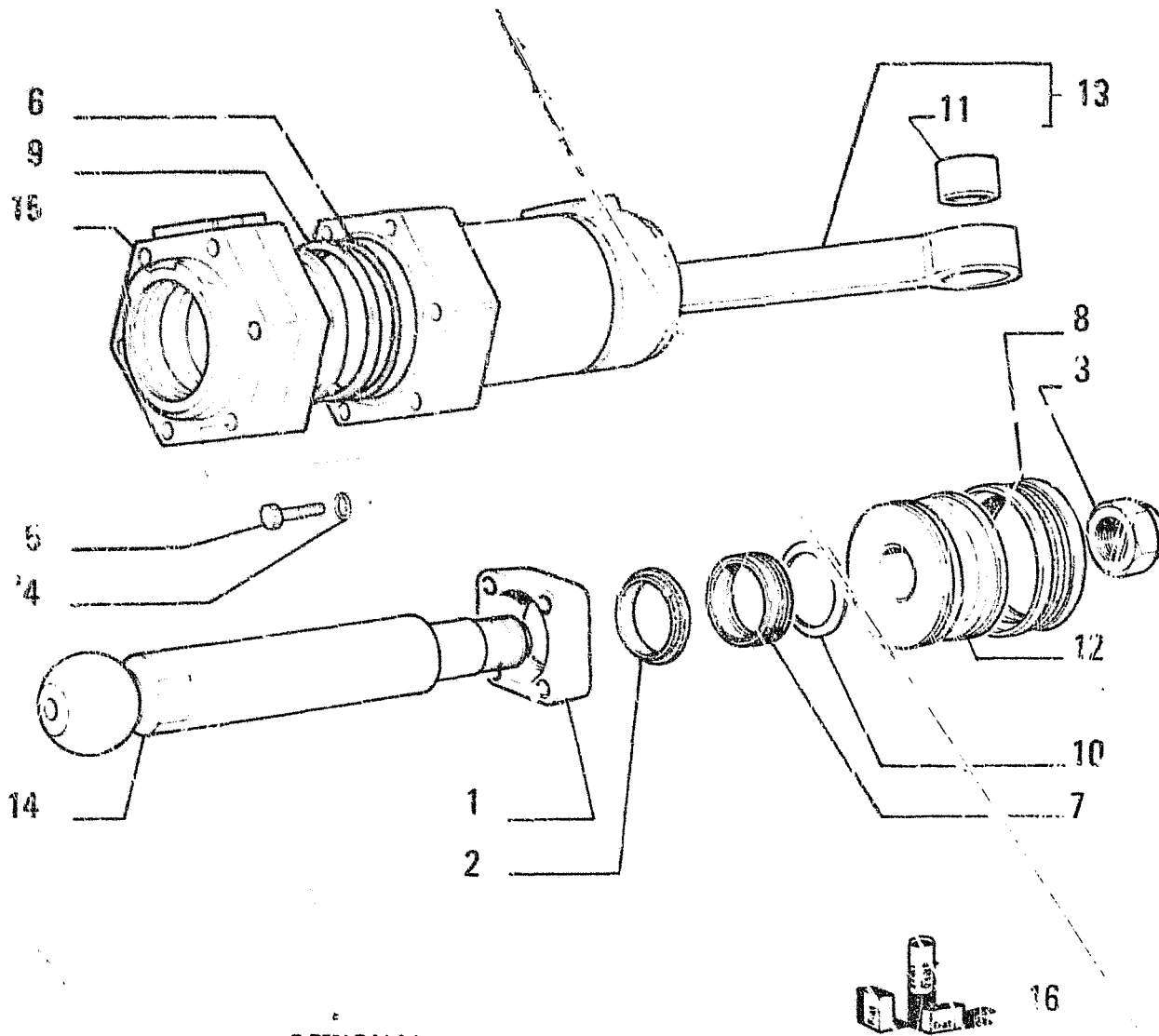

ITEM	PART NUMBER	QTY	TRANS CODE	DESCRIPTION	DESCRIZIONE
16	791071307	1	1K	KIT SEE PAGE 9 D2916	KIT VED. PAG.9 D2916

OPTIONAL VARIANTE 30.1070.09.1

79039545-79047906-76016704
 CYLINDER - CILINDRO - CYLINDRE - ZYLINDER - CILINDRO

1	E3.32/4
N.T.R. 191 - 20.02.1990	
604.01.081.04	

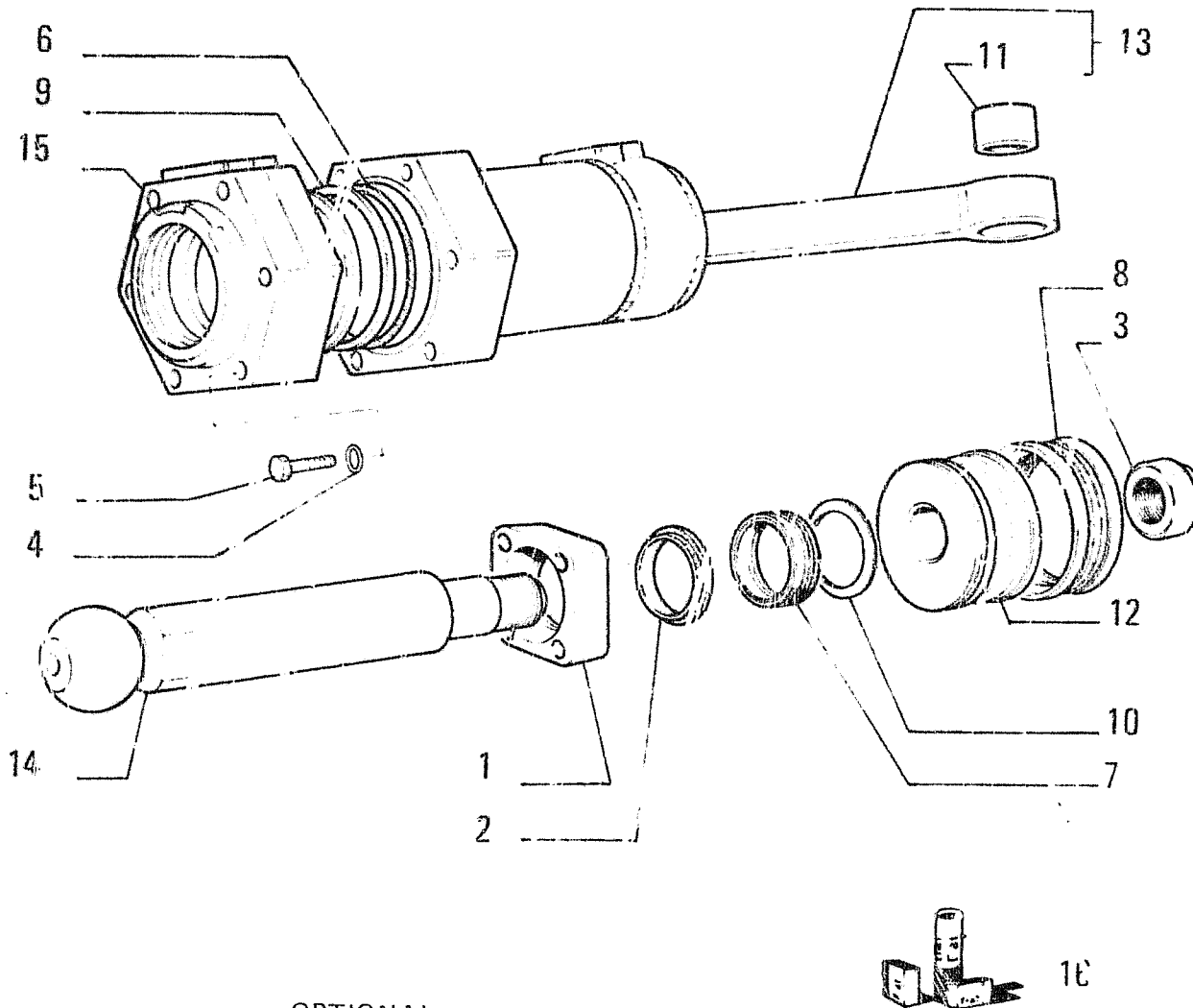

OPTIONAL
VARIANTE 30.107 0.09 1

ITEM	PART NUMBER	QTY	TRANS CODE	DESCRIPTION	DESCRIZIONE
1	8283053	1	70F	FLANGE	FLANGIA
2	8291816	1	42A	MUDSCRAPER RING C2916	ANELLO RASCHIAFANGO C2916
	79065571	1	42A	MUDSCRAPER RING D2916	ANELLO RASCHIAFANGO D2916
3	8292251	1	10D	NUT	DADO
4	10517171	5	133R	SEAL 14,2x3,5	ROSETTA DI TENUTA 14,2x3,5
5	11116831	6	40V	SCREW 14x2x80	VITE 14x2x80
6	14473280	1	158G	O-RING 5,33x113,66	GUARNIZIONE O-R 5,33x113,66
7	79023159	1	158G	O-RING C2916	GUARNIZIONE O-R C2916
	79065569	1	1223	SEAL D2916	GUARNIZIONE D2916
8	79023160	1	158G	O-RING	GUARNIZIONE O-R
9	79023161	1	45A	RING	ANELLO
10	79023162	1	45A	RING C2916	ANELLO C2916
	79065570	1	45A	RING D2916	ANELLO D2916
11	79025284	1	95B	BUSHING	BOCCOLA
12	79038368	1	235S	PISTON	STANTUFFO
13	79039548	1	53C	TUBE - ASSEMBLY	CANNA CILINDRO - COMPLETO
14	79039551	1	74S	ROD	STELO
15	79038367	1	30F	BOTTOM PLATE - FRONT C1612	FONDELLO - ANTERIORE C1612
	79047726	1	81F	BOTTOM PLATE - FRONT D1612	FONDELLO - ANTERIORE D1612
		1	80F	BOTTOM PLATE - FRONT C2948	FONDELLO - ANTERIORE C2948
	79093739	1	80F	BOTTOM PLATE - FRONT D2948	FONDELLO - ANTERIORE D2948

CYLINDER - CILINDRO - CYLINDRE - ZYLINDER - CILINDRO

79039545-79047906-76016704

E3.32/4

N.T.R. 191 - 20.02.1990

601.01.081.04

F

ELECTRICAL SYSTEM • IMPIANTO ELETTRICO • SYSTEME ELECTRIQUE • ELEKTRISCHE ANLAGE • SISTEMA ELETTRICO

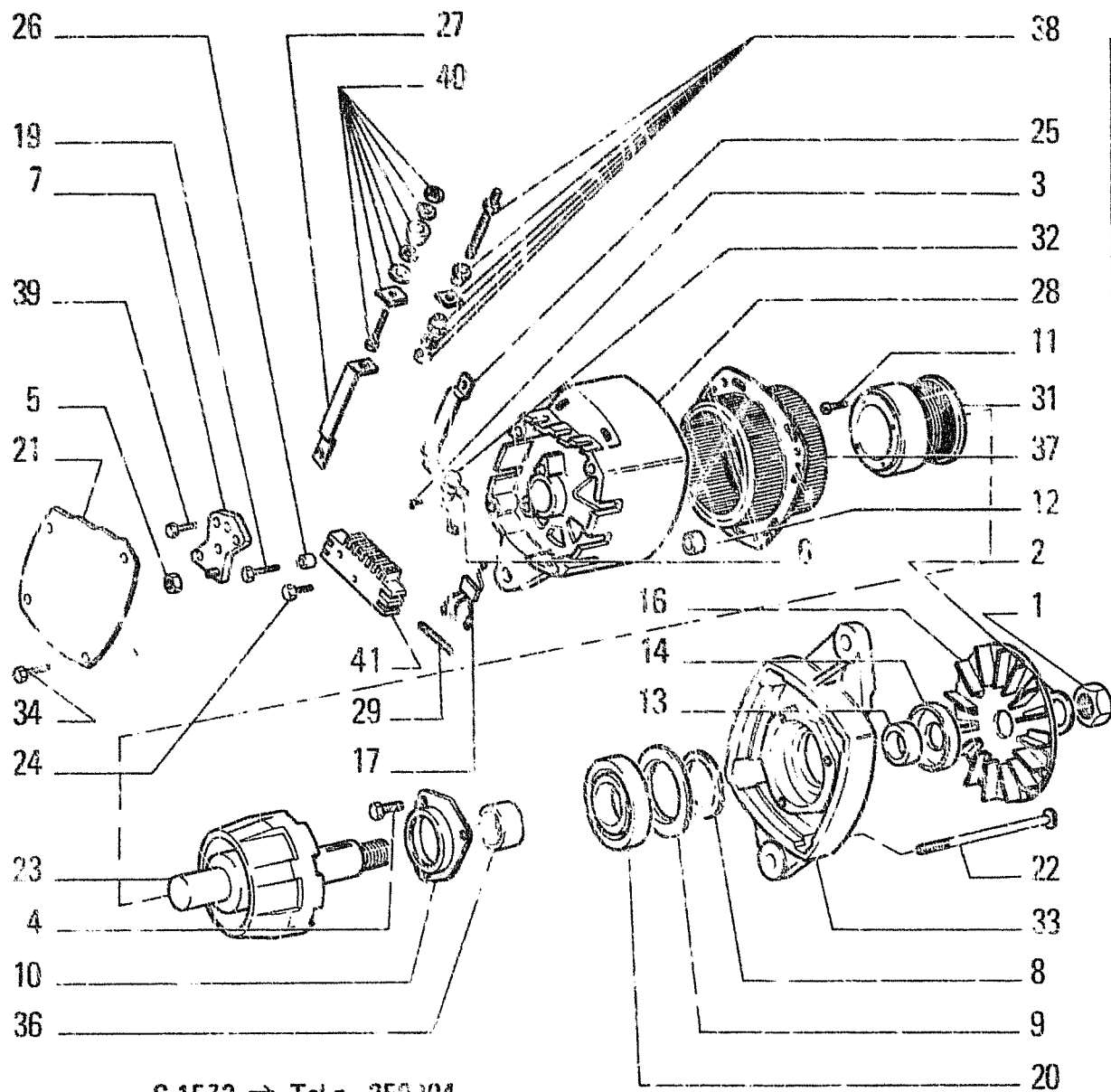

FIATALLIS FD7

F3.03 TAV. 1 PAG.2

ITEM	PART NUMBER	QTY	TRANS CODE	DESCRIPTION	DESCRIZIONE
31	73117746	1	110A	WINDING	AVVOLGIMENTO
32	73117747	1	220C	CONDENSER	CONDENSATORE
33	73117743	1	300S	SUPPORT	SUPPORTO
34	73117750	5	40V	SCREW	VITE
36	73117752	1	95B	BUSHING	BOCCOLA
37	73117754	1	271S	STATOR	STATORE
38	73119570	1	250C	CONTACT	CONTATTO
39	73119636	2	40V	SCREW	VITE
40	73119637	1	250C	CONTACT	CONTATTO
41	73131960	1	39P	RESISTOR	RESISTORE

C 1572 → Tel.n 255904

73119134

ALTERNATOR - ALTERNATORE - ALTERNATEUR - DREHSTROM - LICHT - MASCHINE - ALTERNADOR

F3.03

N.T.R. 158 - 13.03.1987

604.01.081.03

T2

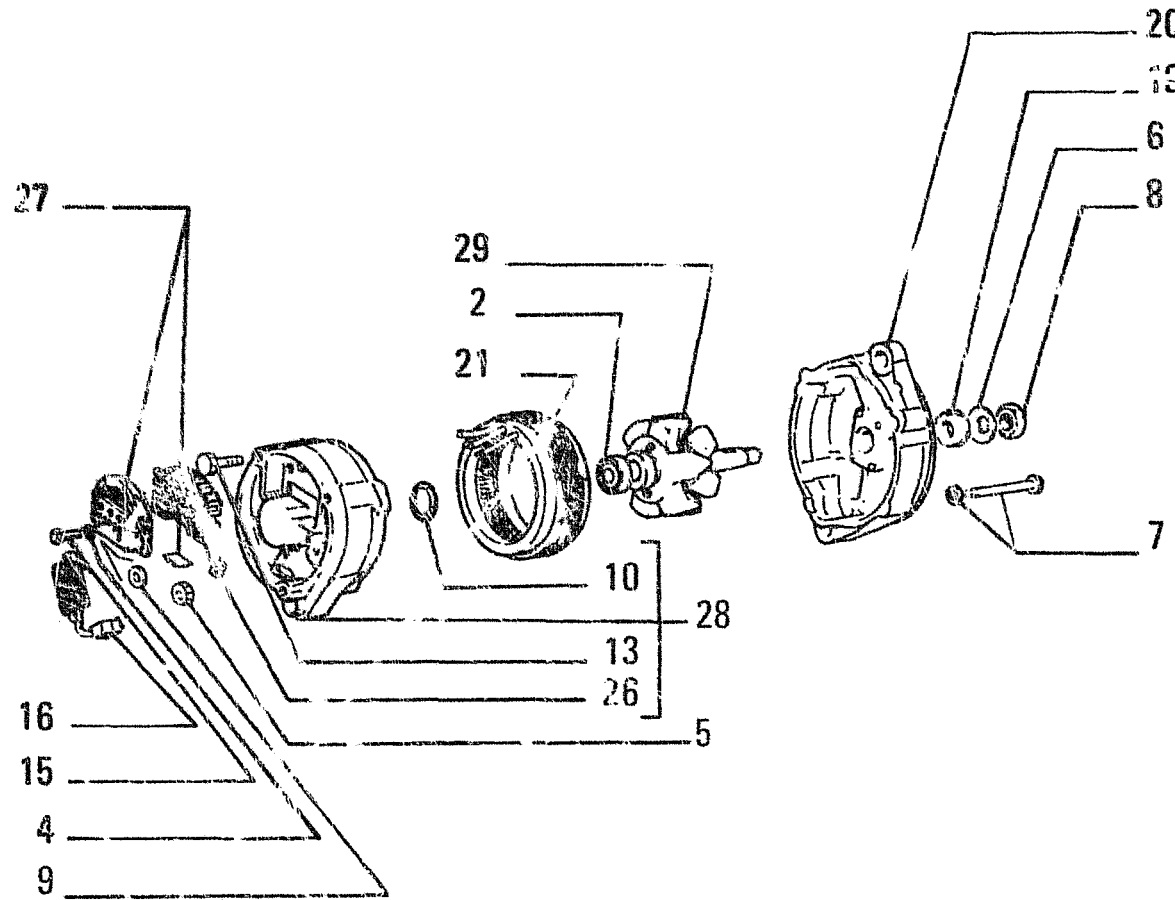

ITEM	PART NUMBER	QTY	TRANS CODE	DESCRIPTION	DESCRIZIONE
2	26996480	1	341C	BEARING	CUSCINETTO
4	10571379	2	170R	LOCKWASHER	ROSETTA EL.
5	14084211	3	10D	NUT 6x1x5,15	DADO 6x1x5,15
6	12035571	1	170R	LOCKWASHER	ROSETTA EL.
7	79070373	3	40V	SCREW	VITE
8	10791311	1	10D	NUT 14x1,5x8	DADO 14x1,5x8
9	14496201	2	131R	WASHER 4,3x9	ROSETTA 4,3x9
10	14454381	1	158G	O-RING	GUARNIZIONE O-R
13	79070374	1	40V	SCREW	VITE
15	10445024	2	40V	SCREW	VITE
16	79070383	1	31R	VOLTAGE REGULATOR	REGOLATORE DI TENSIONE
19	4479391	1	45A	RING	ANELLO
20	79070377	1	300S	SUPPORT	SUPPORTO
21	79070379	1	271S	STATOR	STATORE
26	79070381	1	32P	RECTIFIER	RADDRIZZATORE
27	79070385	1	2K	KIT	KIT
28	79070380	1	300S	SUPPORT	SUPPORTO
29	79070378	1	145R	ROTOR	ROTORE

□ 1572 Tel. n. 250905 →
 C 3447 → Tel. n. 251910



4808519

ALTERNATOR — ALTERNATORE — ALTERNATEUR — DREHSTROMLICHMASCHINE —
 ALTERNADOR

T3

F3.03/A

N.T.R. 205 - 30.09.1991
 604.01.081.06

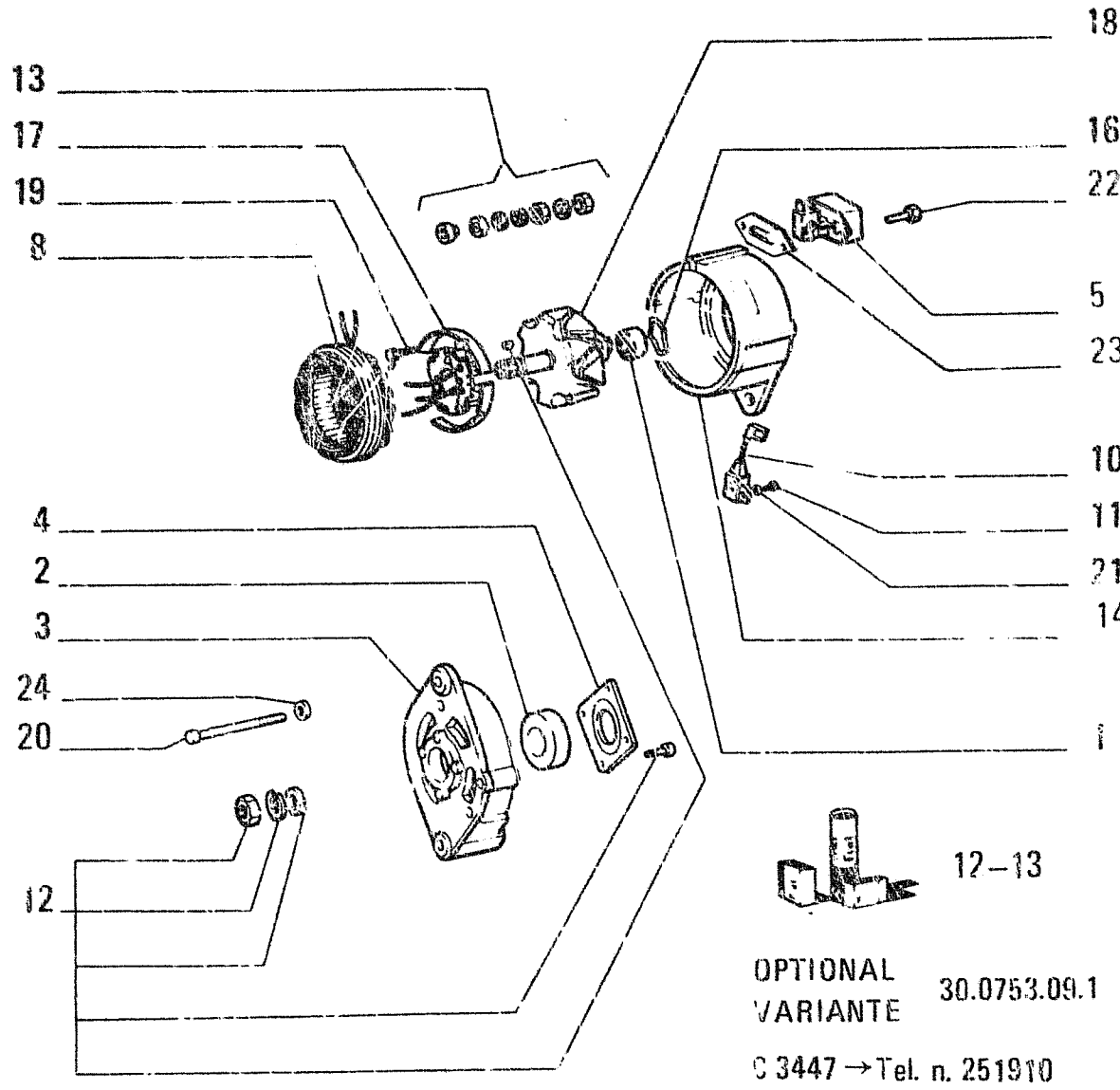

ITEM	PART NUMBER	QTY	TRANS CODE	DESCRIPTION	DESCRIZIONE
1	24941650	1	341C	BEARING 12x32	CUSCINETTO 12x32
2	24941660	1	341C	BEARING 17x47	CUSCINETTO 17x47
3	79074704	1	300C	SUPPORT	SUPPORTO
4	79022488	1	105P	PLATE	PIASTRA
5	79074715	1	169R	REGULATOR	REGOLATORE
8	79074705	1	271S	STATOR	STATORE
10	79074709	1	220C	CONDENSER	CONDENSATORE
11	79074711	1	40V	SCREW	VITE
12	79022481	1	2K	KIT	KIT
13	79074707	1	2K	KIT	KIT
14	79074708	1	300S	SUPPORT	SUPPORTO
16	79025494	1	158G	O-RING	GUARNIZIONE O-R
17	79074712	1	32R	RECTIFIER	RADDRIZZATORE
18	79074713	1	145R	ROTOR	ROTORE
19	79074706	2	40V	SCREW	VITE
20	79074702	4	40V	SCREW	VITE
21	79074710	3	170R	LOCKWASHER	ROSETTA EL.
22	79075883	2	40V	SCREW	VITE
23	79074714	1	120G	GASKET	GUARNIZIONE PIANA
24	14497821	4	131R	WASHER	ROSETTA

12-13
 OPTIONAL VARIANTE 30.0753.09.1
 C 3447 -> Tel. n. 251910

4757193 (Bosch) 55 A
 ALTERNATOR - ALTERNATORE - ALTERNATEUR - DREHSTROM - LICHT - MASCHINE - ALTERNADOR

F3.03/1
 N.T.R. 205 - 20.09.1991
 60-1.61.001.06

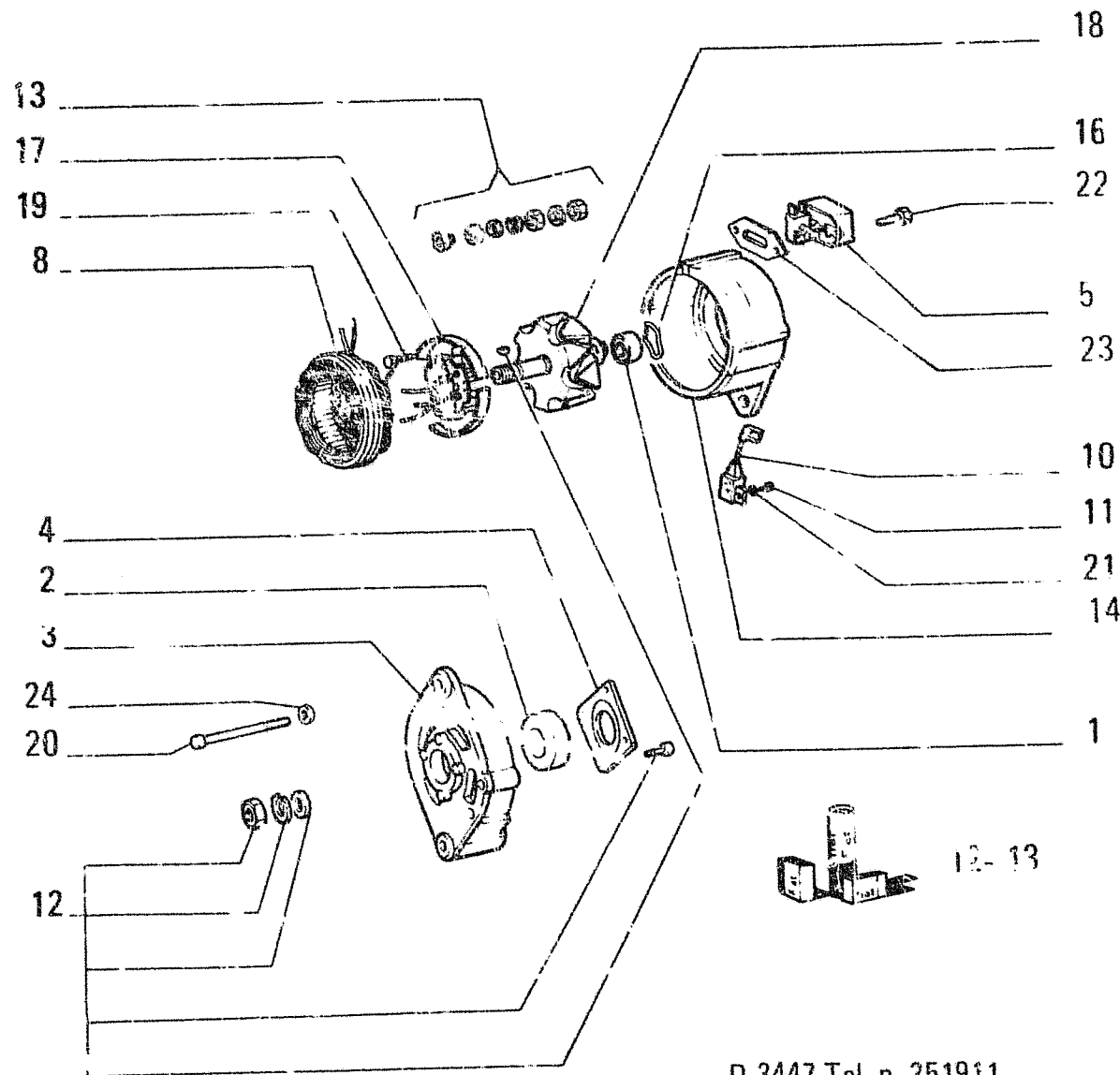

D 3447 Tel. n. 251911

ITEM	PART NUMBER	QTY	TRANS CODE	DESCRIPTION	DESCRIZIONE
					18
					16
					22
1	24941650	1	341C	BEARING 12x32	CUSCINETTO 12x32
2	24941660	1	341C	BEARING 17x47	CUSCINETTO 17x47
3	79074704	1	300S	SUPPORT	SUPPORTO
4	7902246B	1	105P	PLATE	PIASTRA
5	79074715	1	169R	REGULATOR	REGOLATORE
8	79074705	1	271S	STATOR	STATORE
10	79074709	1	220C	CONDENSER	CONDENSATORE
11	79074711	1	40V	SCREW	VITE
12	79022484	1	2K	KIT	KIT
13	79074707	1	2K	KIT	KIT
14	79074708	1	300S	SUPPORT	SUPPORTO
16	79025494	1	158G	O-RING	GUARNIZIONE O-R
17	79074712	1	32R	RECTIFIER	RADDRIZZATORE
18	79074713	1	145R	ROTOR	ROTORE
19	79074706	2	40V	SCREW	VITE
20	79074702	4	40V	SCREW	VITE
21	79074710	3	170R	LOCKWASHER	ROSETTA EL
22	79075863	2	40V	SCREW	VITE
23	79074714	1	120G	GASKET	GUARNIZIONE PIANA
24	14497821	4	131R	WASHER	ROSETTA

4757193 (Bosch) 55 A

ALTERNATOR -- ALTERNATORE -- ALTERNATEUR -- DREHSTROM - LICHT - MASCHINE -- ALTERNADOR

F3.03/1A

N.T.R. 205 - 30.09.1991
604.01.081.06

T5

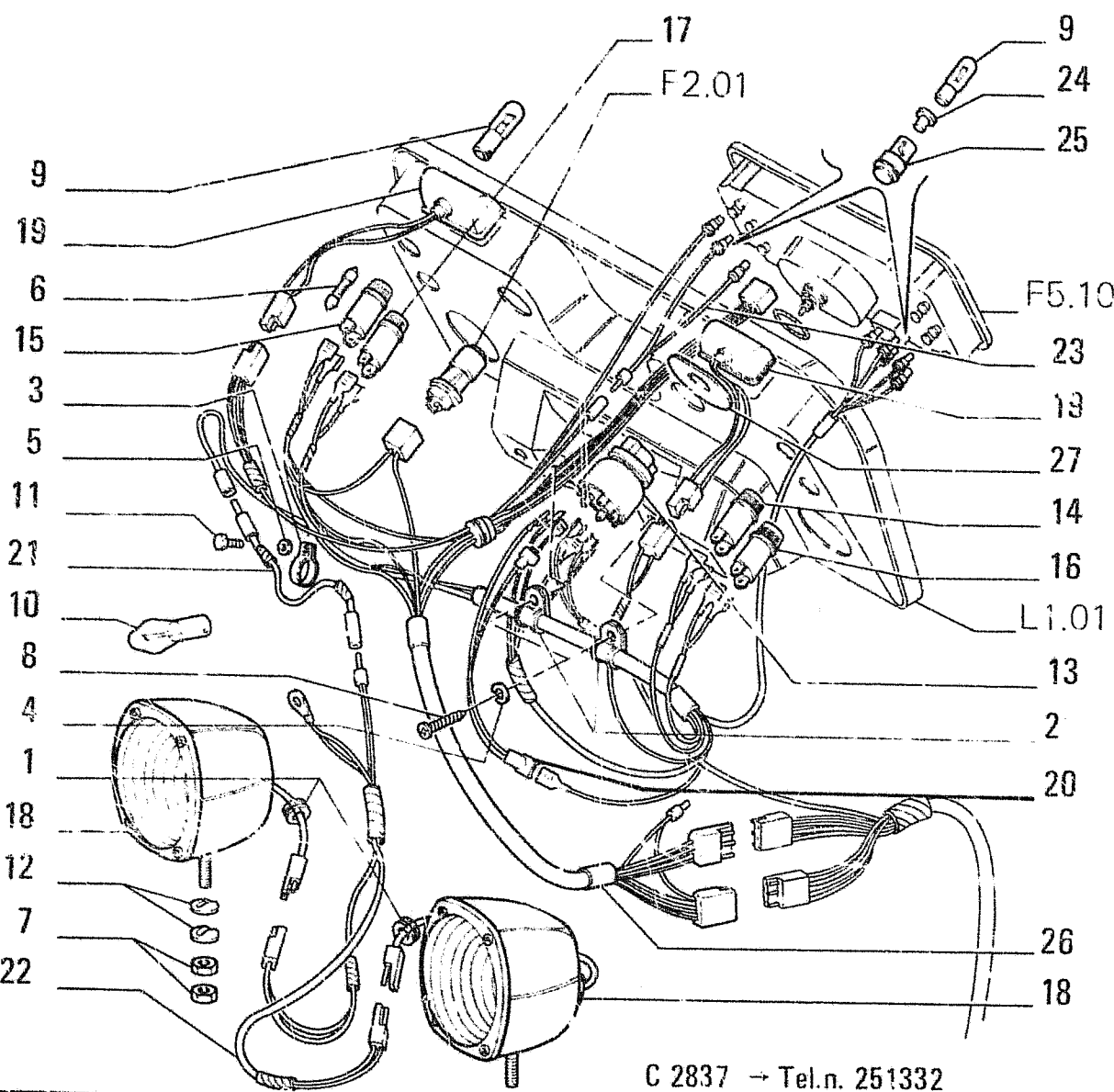

ITEM	PART NUMBER	QTY	TRANS CODE	DESCRIPTION	DESCRIZIONE
1	10399260	2	48A	RUBBER RING 8x20	ANELLO DI GOMMA 8x20
2	10441590	2	231S	CLIP 16x7	STAFFETTA 16x7
3	10450090	7	231S	CLIP 8x9	STAFFETTA 8x9
		1	231S	CLIP 8x9 D2937	STAFFETTA 8x9 D2937
4	10571571	2	132R	LOCKWASHER 6,1x1,6	ROSETTA DI SICUREZZA 6,1x1,6
5	10571771	7	132R	LOCKWASHER 8,1x2	ROSETTA DI SICUREZZA 8,1x2
6	11052090	4	110F	FUSE 6x25	FUSIBILE 6x25
7	11702921	4	10D	NUT 12x1,75x10	DADO 12x1,75x10
8	13275811	2	40V	SCREW 6x1x8	VITE 6x1x8
9	14142490	10	30L	LAMP 9,15x8,8	LAMPADA 9,15x8,8
10	14142690	2	30L	LAMP 20x35,5	LAMPADA 20x35,5
11	16043031	7	40V	SCREW 8x1,25x12	VITE 8x1,25x12
12	76000905	4	SOT	BLOCK	TASSELLO
13	79006370	1	21JC	SWITCH	COMMUTATORE
14	79011643	1	188P	FUSE HOLDER	PORTAFUSIBILE
15	79011645	1	188P	FUSE HOLDER	PORTAFUSIBILE
16	79011647	1	188P	FUSE HOLDER	PORTAFUSIBILE
17	79011649	1	188P	FUSE HOLDER	PORTAFUSIBILE
18	79032396	2	220P	FLOODLIGHT - ASSEMBLY SEE SGR. F4.05	PROIETTORE - COMPLETO VEDERE SGR. F4.05
19	79032398	2	12F	INSTRUMENT LAMP	FANALE DEL CRUSCOTTO
20	79037299	1	111C	CABLE	CAVO
21	79037303	1	111C	CABLE	CAVO
22	79037304	1	111C	CABLE - FRONT	CAVO - ANTERIORE
23	79042311	1	111C	CABLE	CAVO
24	79042612	8	60C	WIRE TERMINAL	CASOCORDA
25	79042813	8	193P	BULB HOLDER	PORTALAMPADA

LIGHTING SYSTEM - ILLUMINAZIONE - ECLAIRAGE - BELEUCHTUNG - SISTEMA DE ALUMBRADO

2

F4.01	1
N.T.R. 191 - 20.02.1990	
604.01.081.04	

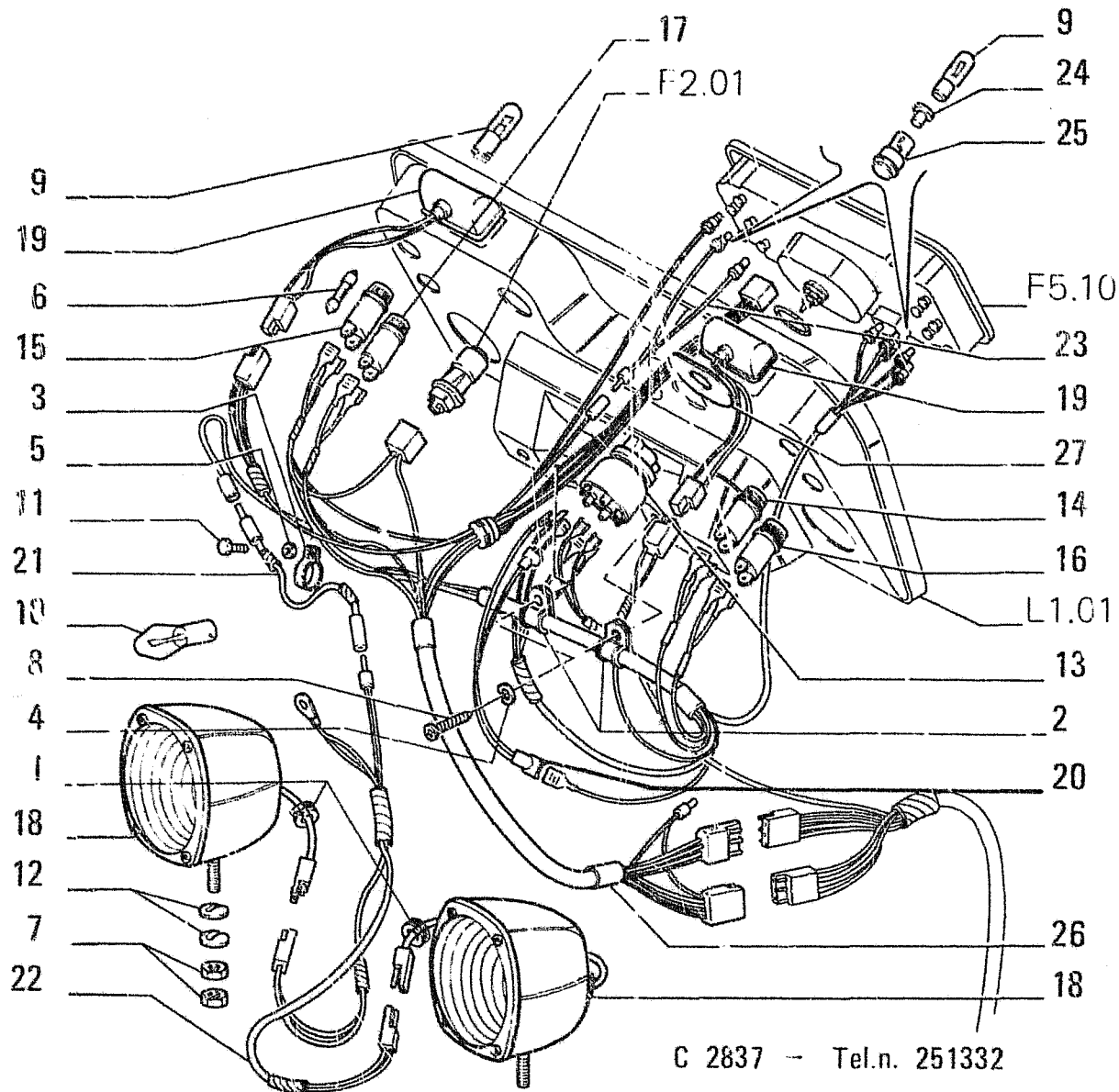

C 2837 - Tel.n. 251332

I T E M	PART NUMBER	Q T Y	TRANS CODE	DESCRIPTION	DESCRIZIONE
26	76010396	1	111C	CABLE D1510	CAVO D1510
	79042823	1	111C	CABLE C1510	CAVO C1510
27	79043274	1	65T	DECAL	TARGA

LIGHTING SYSTEM - ILLUMINAZIONE - ECLAIRAGE - BELEUCHTUNG - SISTEMA DE ALUMBRADO

2

F4.01

1

N.T.R. 191 - 20.02.1990

604.01.081.04

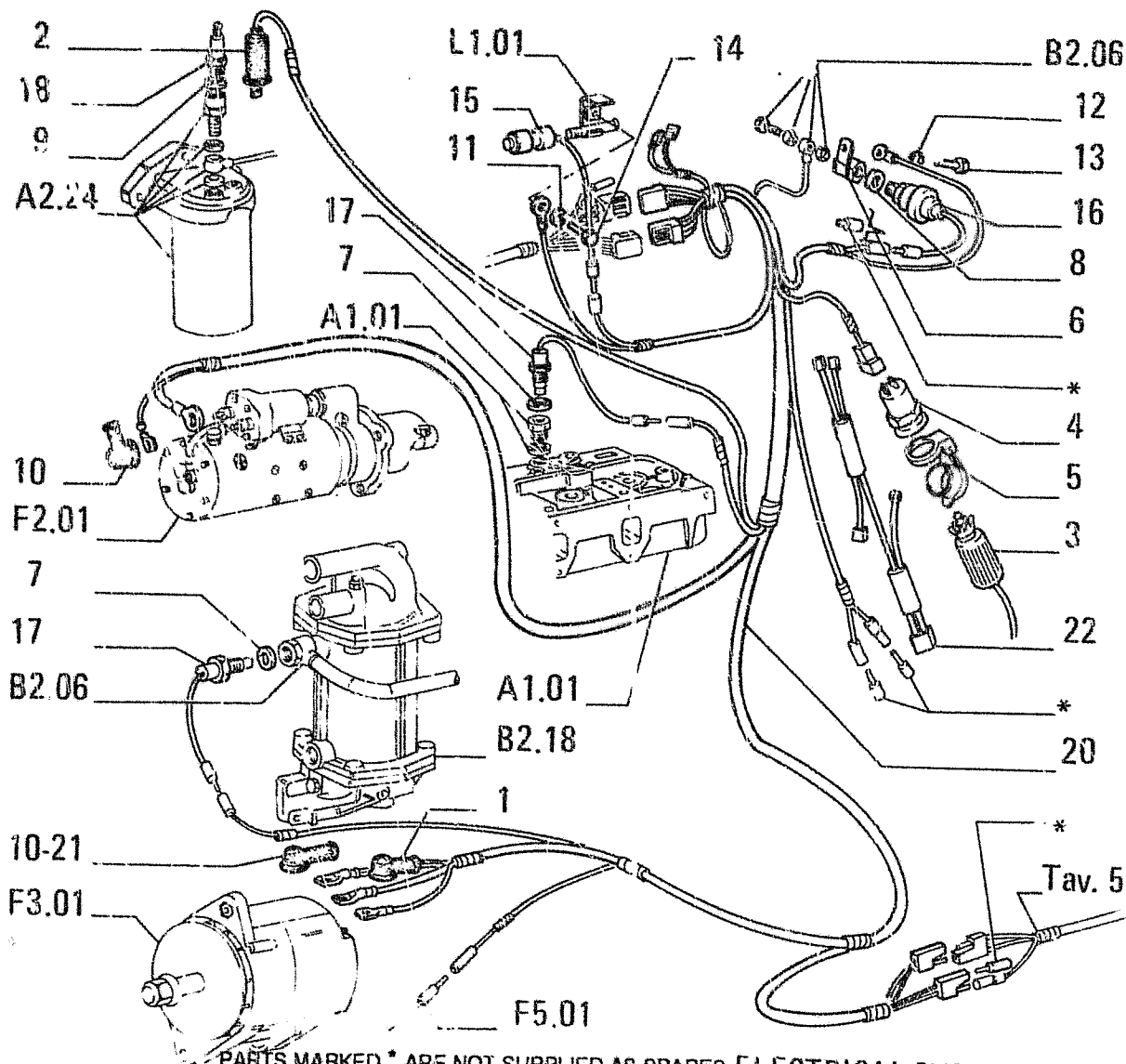

PARTS MARKED * ARE NOT SUPPLIED AS SPARES ELECTRICAL SYSTEM
 I PARTICOLARI CONTRASSEGNAATI CON * NON IMPIANTO ELETTRICO
 VENGONO FORNITI DI RICAMIO

FIAT/LANCIA FD7

F4.01 TAV. 2 PAG.1

ITEM	PART NUMBER	QTY	TRANS CODE	DESCRIPTION	DESCRIZIONE
1	4094230	1	65C BOOT	CAPPUCCIO	CAPPUCCIO
2	4151244	1	65C BOOT	CAPPUCCIO	CAPPUCCIO
3	4182461	1	201S ELECTRICAL PLUG	SPINA ELETTRICA	SPINA ELETTRICA
4	4182462	1	205P RECEPTACLE	PRESA DI CORRENTE	PRESA DI CORRENTE
5	4952553	1	265C COVER	COPERCHIO	COPERCHIO
6	4957531	1	300S SUPPORT C2954	SUPPORTO C2954	SUPPORTO C2954
7	10257060	2	133R SEAL 18,2x22	ROSETTA DI TENUTA 18,2x22	ROSETTA DI TENUTA 18,2x22
8	10257460	1	133R SEAL 20,2x26 C2954	ROSETTA DI TENUTA 20,2x26 C2954	ROSETTA DI TENUTA 20,2x26 C2954
9	10298360	1	133R SEAL 10,2x16	ROSETTA DI TENUTA 10,2x16	ROSETTA DI TENUTA 10,2x16
10	10405485	1	65C BOOT 7,7x15	CAPPUCCIO 7,7x15	CAPPUCCIO 7,7x15
11	10571771	1	65C BOOT 7,7x15 C2938	CAPPUCCIO 7,7x15 C2938	CAPPUCCIO 7,7x15 C2938
12	10571871	1	132R LOCKWASHER 10,2x2,2 C2954	ROSETTA DI SICUREZZA 10,2x2,2 C2954	ROSETTA DI SICUREZZA 10,2x2,2 C2954
13	111106031	1	40V SCREW 10x1,5x20 C2954	VITE 10x1,5x20 C2954	VITE 10x1,5x20 C2954
14	16043031	1	40V SCREW 8x1,25x12 C1510	VITE 8x1,25x12 C1510	VITE 8x1,25x12 C1510
15	79030400	1	87S INDICATOR AIR FILTER CLOGGING C1510	SEGNALATORE AIR FILTER CLOGGING C1510	SEGNALATORE AIR FILTER CLOGGING C1510
	79058644	1	87S INDICATOR - IN ALTERNATIVE AIR FILTER CLOGGING D1510	SEGNALATORE - IN ALTERNATIVA AIR FILTER CLOGGING D1510	SEGNALATORE - IN ALTERNATIVA AIR FILTER CLOGGING D1510
	79066478	1	87S INDICATOR C2873	SEGNALATORE C2873	SEGNALATORE C2873
		1	87S INDICATOR - IN ALTERNATIVE AIR FILTER CLOGGING	SEGNALATORE - IN ALTERNATIVA AIR FILTER CLOGGING	SEGNALATORE - IN ALTERNATIVA AIR FILTER CLOGGING

LIGHTING SYSTEM - ILLUMINAZIONE - ECLAIRAGE - BELEUCHTUNG - SISTEMA DE ALUMBRADO

2

F4.01

2

M.T. 6. 205 - 30.09.1991
 604.01.081.06

T8

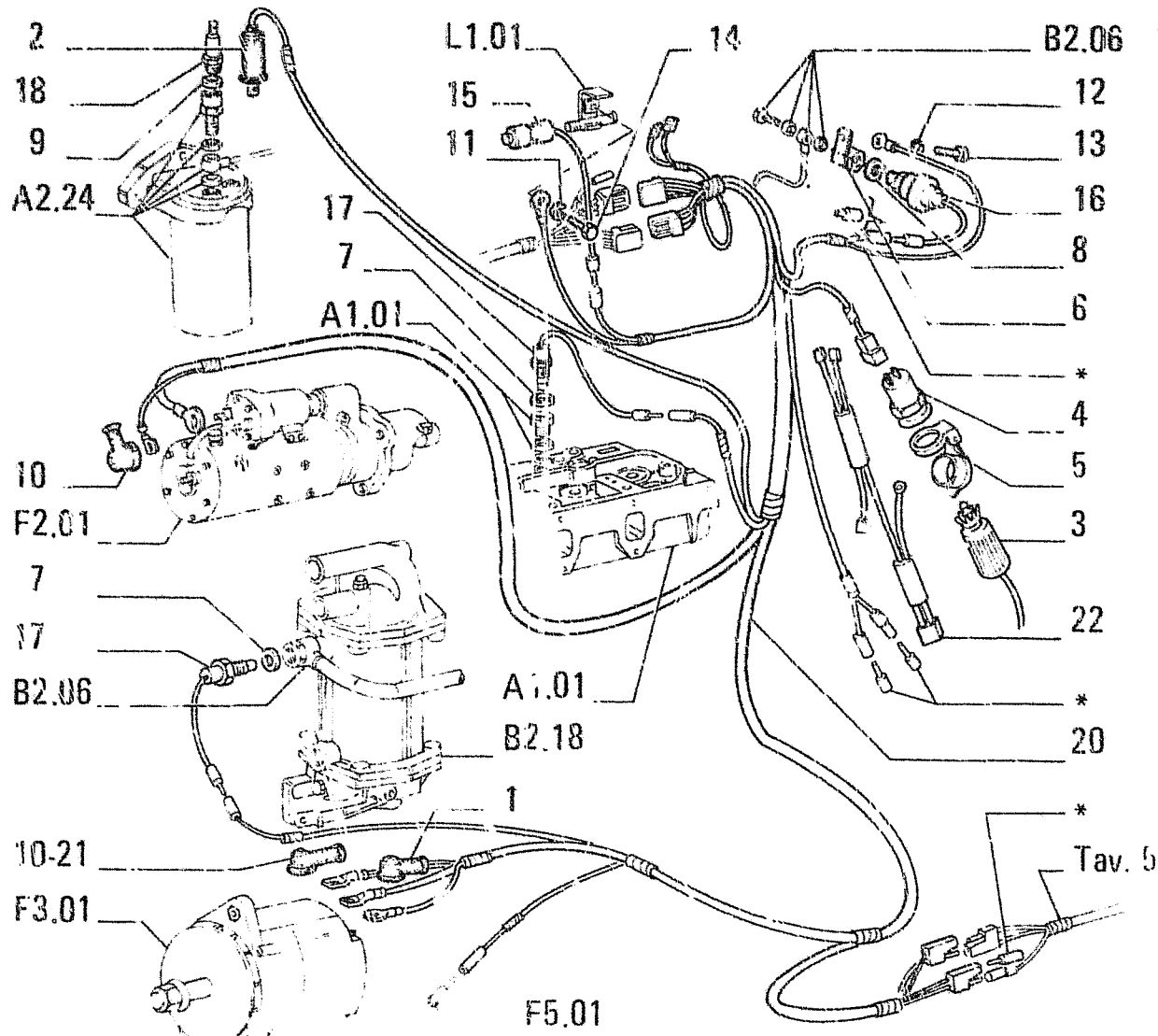

PARTS MARKED * ARE NOT SUPPLIED AS SPARES
I PARTICOLARI CONTRASSEGNA TI CON * NON
VENGONO FORNITI DI RICAMBIO

ELECTRICAL SYSTEM
IMPIANTO ELETTRICO

ITEM	PART NUMBER	QTY	TRANS CODE	DESCRIPTION	DESCRIZIONE
15	79081900	1	87S	INDICATOR D2873	SEGNALATORE D2873
16	79033172	1	75I	SWITCH TRANSMISSION FLUID PRESSURE C1580	INTERRUTTORE TRANSMISSION FLUID PRESSURE C1580
	79076344	1	75I	SWITCH TRANSMISSION FLUID PRESSURE D1580	INTERRUTTORE TRANSMISSION FLUID PRESSURE D1580
		1	75I	SWITCH TRANSMISSION FLUID PRESSURE C2954	INTERRUTTORE TRANSMISSION FLUID PRESSURE C2954
17	79035418	2	160T	SENDING UNIT TRANSMISSION FLUID PRESSURE C2905	TRASMETTITORE TRANSMISSION FLUID PRESSURE C2905
	79072543	2	160T	SENDING UNIT TRANSMISSION FLUID PRESSURE D2905	TRASMETTITORE TRANSMISSION FLUID PRESSURE D2905
18	79039833	1	75I	SWITCH FUEL FILTER CLOGGING C1523	INTERRUTTORE FUEL FILTER CLOGGING C1523
	79048771	1	75I	SWITCH - IN ALTERNATIVE FUEL FILTER CLOGGING D1523	INTERRUTTORE - IN ALTERNATIVA FUEL FILTER CLOGGING D1523
		1	75I	SWITCH ALT.FUEL FILTER CLOGGING C2845	INTERRUTTORE ALT.FUEL FILTER CLOGGING C2845
	79050321	1	75I	SWITCH - IN ALTERNATIVE FUEL FILTER CLOGGING	INTERRUTTORE - IN ALTERNATIVA FUEL FILTER CLOGGING

LIGHTING SYSTEM - ILLUMINAZIONE - ECLAIRAGE - BELEUCHTUNG - SISTEMA DE ALUMBRADO

2

F4.01

2

N.T.R. 205 - 30.09.1991
604.01.081.06

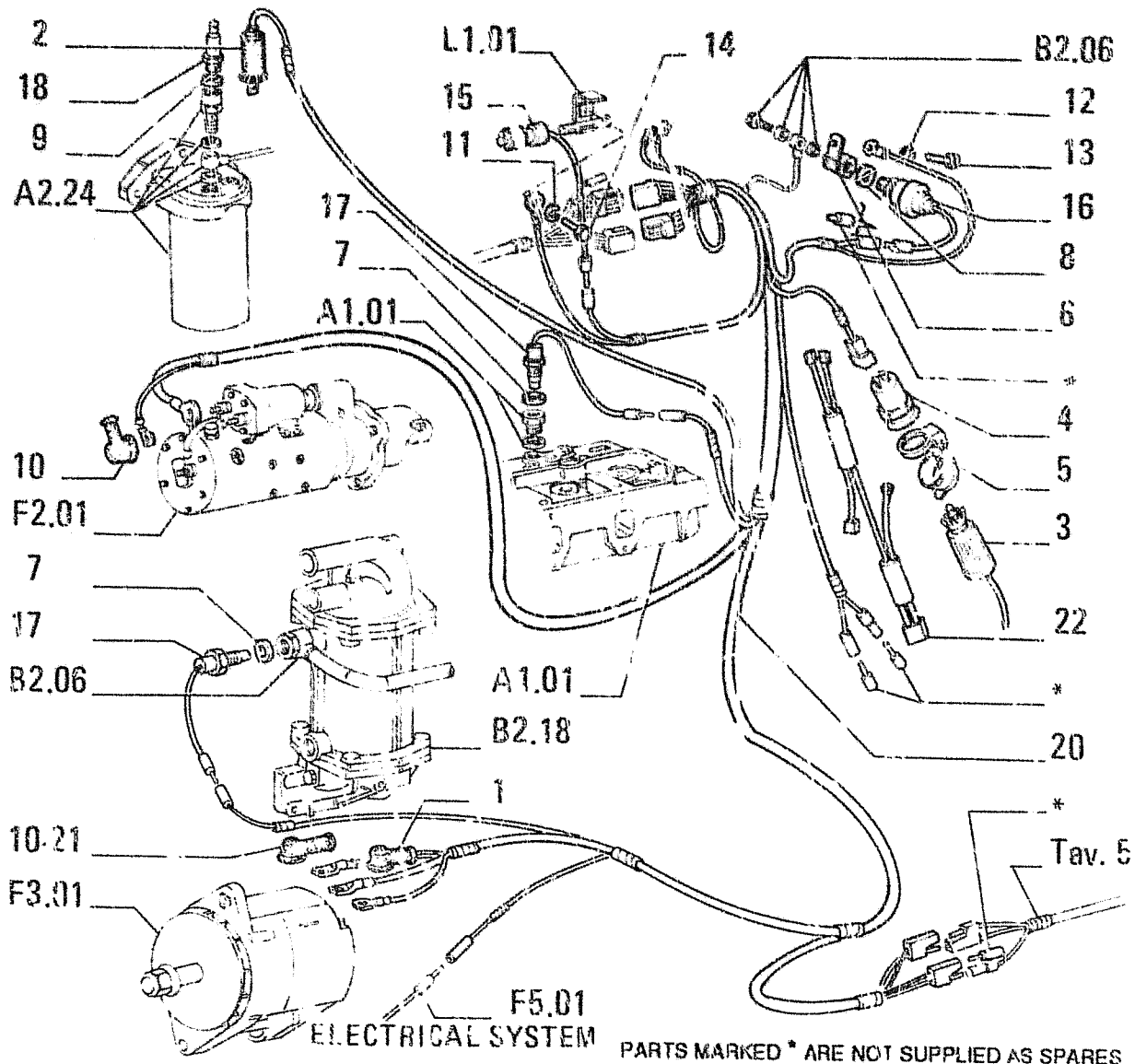

F5.01
ELECTRICAL SYSTEM
IMPIANTO ELETTRICO
 PARTS MARKED * ARE NOT SUPPLIED AS SPARES
 I PARTICOLARI CONTRAS SEGNATI CON * NON VENGONO FORNITI DI RICAMBIO

ITEM	PART NUMBER	QTY	TRANS CODE	DESCRIPTION	DESCRIZIONE
18	79050321	1	D1523	7SI SWITCH - IN ALTERNATIVE FUEL FILTER CLOGGING	D1523 INTERRUTTORE - IN ALTERNATIVA FUEL FILTER CLOGGING
20	76010585	1	111C	CABLE D1510	C2845 CAVO D1510
	79043371	1	111C	CABLE C1510	C/VO C.1510
21	79101480	1	85C	BOOT D2938	LAPPUCCHIO D2938
22	76019025	1	111C	CABLE D2937	CAVO D2937

LIGHTING SYSTEM - ILLUMINAZIONE - ECLAIRAGE - BELEUCHTUNG - SISTEMA DE ALUMBRADO

2 F4.01 2

N.T.R. 205 - 30.09.1991
 804.01.081.06

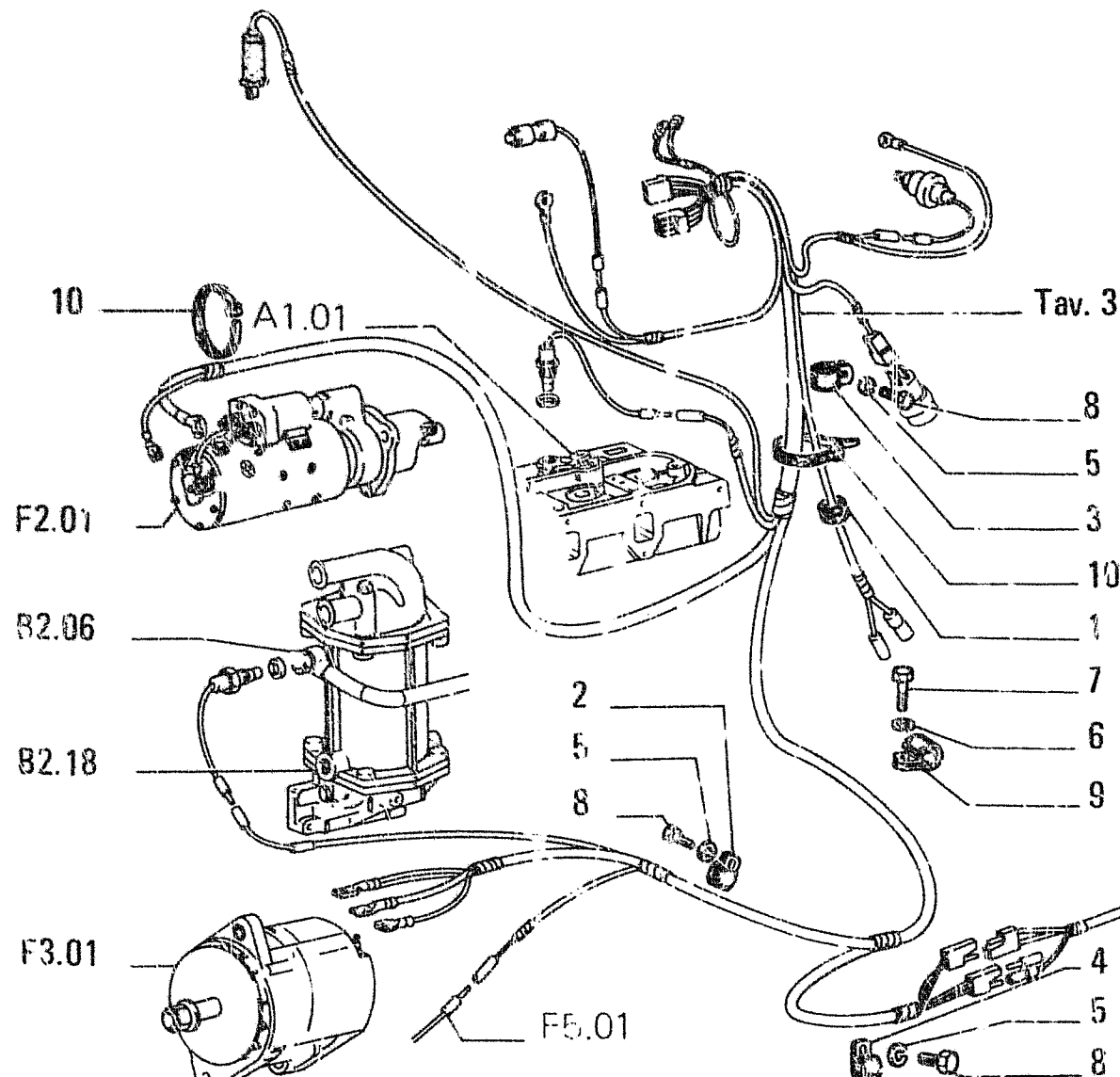

ELECTRICAL SYSTEM
IMPIANTO ELETTRICO

ITEM	PART NUMBER	QTY	TRANS CODE	DESCRIPTION	DESCRIZIONE
1	10397380	1	48A	RUBBER RING 12x24	ANELLO DI GOMMA 12x24
2	10450390	2	231S	CLIP 14x9	STAFFETTA 14x9
3	10450690	2	231S	CLIP 20x9	STAFFETTA 20x9
4	10450790	8	231S	CLIP 22x9	STAFFETTA 22x9
5	10571771	12	132R	LOCKWASHER 8,1x2	ROSETTA DI SICUREZZA 8,1x2
6	10571871	1	132R	LOCKWASHER 10,2x2,2	ROSETTA DI SICUREZZA 10,2x2,2
7	15970531	1	40V	SCREW 10x1,25x20	VITE 10x1,25x20
8	16043031	12	40V	SCREW 8x1,25x12	VITE 8x1,25x12
9	79011405	1	231S	CLIP	STAFFETTA
		2	231S	CLIP (*) D3212	STAFFETTA (*) D3212
10	79013422	3	31F	CLAMP	FASCETTA
		4	31F	CLAMP D2937	FASCETTA D2937
		2	31F	CLAMP (*) D3212	FASCETTA (*) D3212
(*)				469P FOR SPECIAL EQUIPMENT 30.9116.08.1	PER VARIANTE 30.9116.08.1

LIGHTING SYSTEM - ILLUMINAZIONE - ECLAIRAGE - BELEUCHTUNG - SISTEMA DE ALUMBRADO

2	F4.01	3
N.T R. 200 - 15.10.1990		
604.01.081.05		

ELECTRICAL SYSTEM
IMPIANTO ELETTRICO

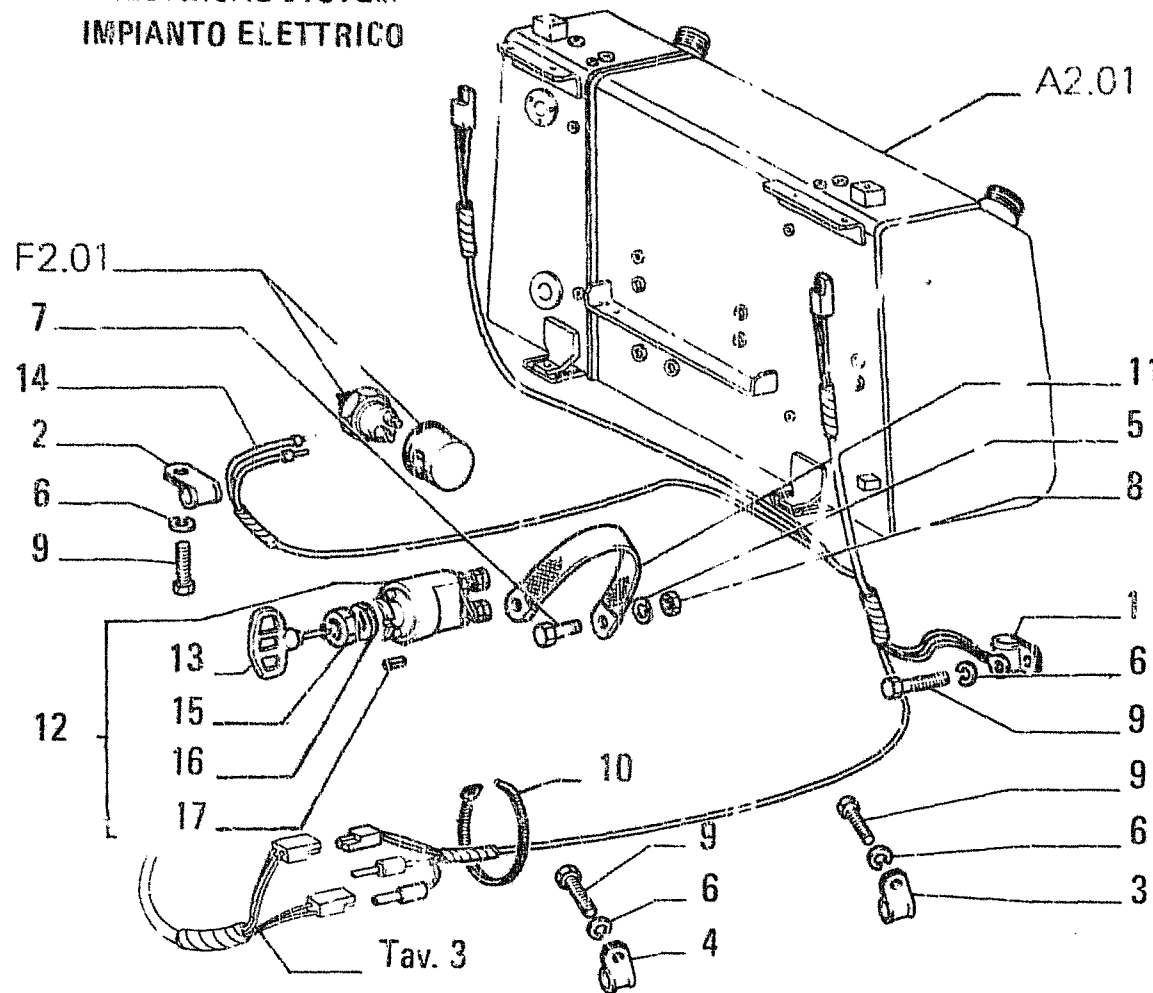

I T E M	PART NUMBER	Q T Y	TRANS CODE	DESCRIPTION	DESCRIZIONE
1	10449890	4	231S	CLIP 6x9	STAFFETTA 6x9
2	10450090	3	231S	CLIP 8x9	STAFFETTA 8x9
3	10450290	2	231S	CLIP 74x9	STAFFETTA 74x9
4	10450790	1	231S	CLIP 22x9	STAFFETTA 22x9
5	10517071	2	132R	LOCKWASHER 12,2x3,1	ROSETTA DI SICUREZZA 12,2x3,1
6	10571771	10	132R	LOCKWASHER 8,1x2	ROSETTA DI SICUREZZA 8,1x2
7	10979331	1	40V	SCREW 10x1,5x14	VITE 10x1,5x14
8	11701721	1	10D	NUT 10x1,5x8	DADO 10x1,5x8
9	16043031	10	40V	SCREW 8x1,25x12	VITE 8x1,25x12
10	79013422	1	31F	CLAMP	FASCETTA
11	79017173	1	166T	GROUND BRAID	TRECCIA DI MASSA
12	79031355	1	75I	SWITCH - ASSEMBLY BATTERIES-NEUTRALIZER C1117	INTERRUTTORE - COMPLETO BATTERIES-NEUTRALIZER C1117
	79048326	1	75I	SWITCH - ASSEMBLY BATTERIES NEUTRALIZER D1117	INTERRUTTORE - COMPLETO BATTERIES NEUTRALIZER D1117
		1	75I	SWITCH - ASSEMBLY BATTERIES NEUTRALIZER C1581	INTERRUTTORE - COMPLETO BATTERIES NEUTRALIZER C1581
	79073031	1	75I	SWITCH - ASSEMBLY BATTERIES NEUTRALIZER D1581	INTERRUTTORE - COMPLETO BATTERIES NEUTRALIZER D1581
13	79032280	1	154C	LOCK KEY C1581	CHIAVE SERRATURA C1581
	79073033	2	154C	LOCK KEY D1581	CHIAVE SERRATURA D1581
14	79057301	1	111C	CABLE - REAR	CAVO - POSTERIORE
15	79038734	1	10D	NUT D1581	DADO D1581

LIGHTING SYSTEM - ILLUMINAZIONE - ECLAIRAGE - BELEUCHTUNG - SISTEMA DE ALUMBRADO

2

F.4.01

4

N.T.R. 158 - 13.03.1987
604.01.081.03

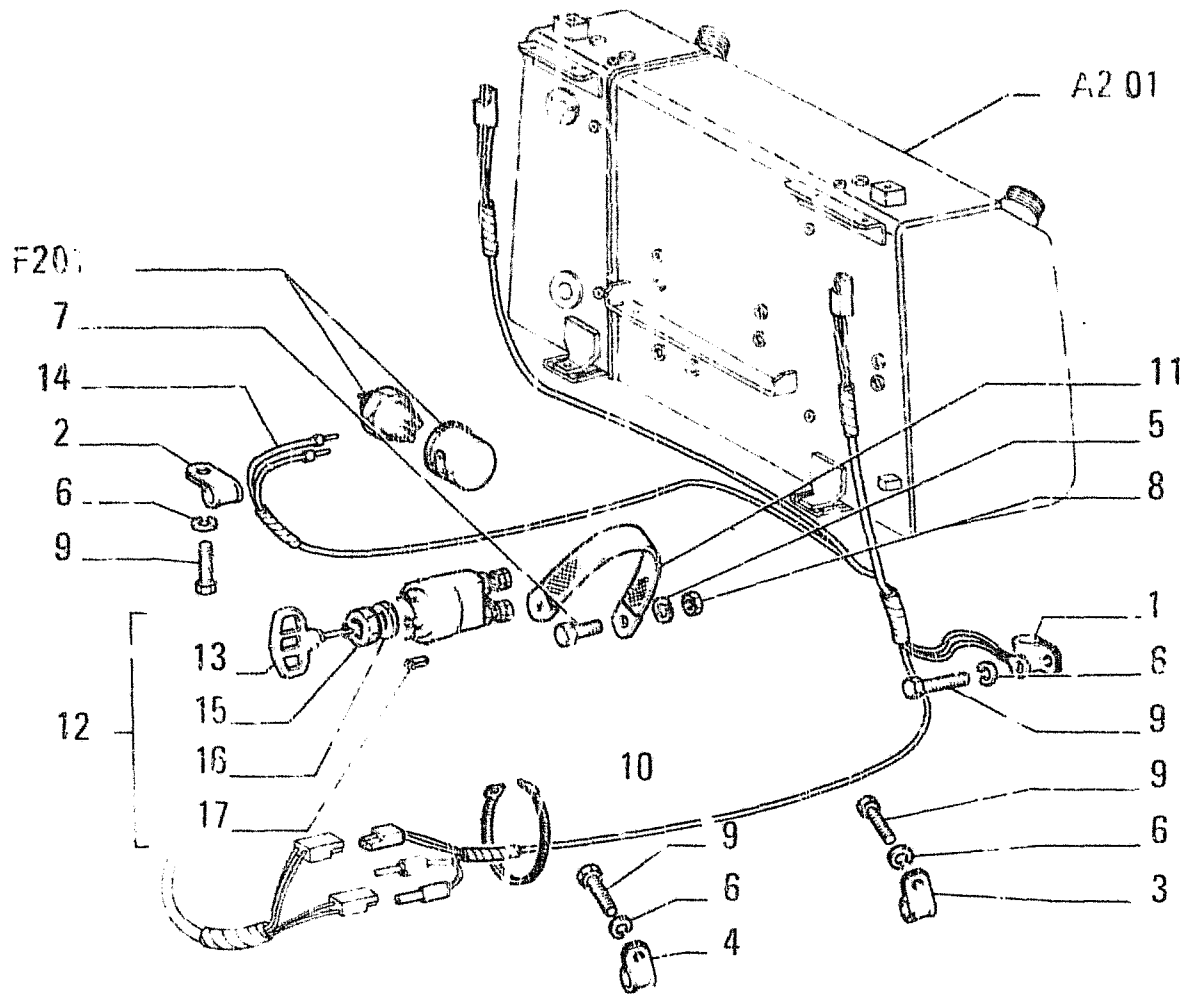

ITEM	PART NUMBER	QTY	TRANS CODE	DESCRIPTION	DESCRIZIONE
16	79038735	1	170R	LOCKWASHER D1501	ROSETTA EL. D1501
17	14163470	1	202S	SPRING PIN 4,4x10 D1501	SPINA ELASTICA 4,4x10 D1501

LIGHTING SYSTEM -- ILLUMINAZIONE -- ECLAIRAGE -- BELEUCHTUNG -- SISTEMA DE ALUMBRADO

2

F4.01

4

T13

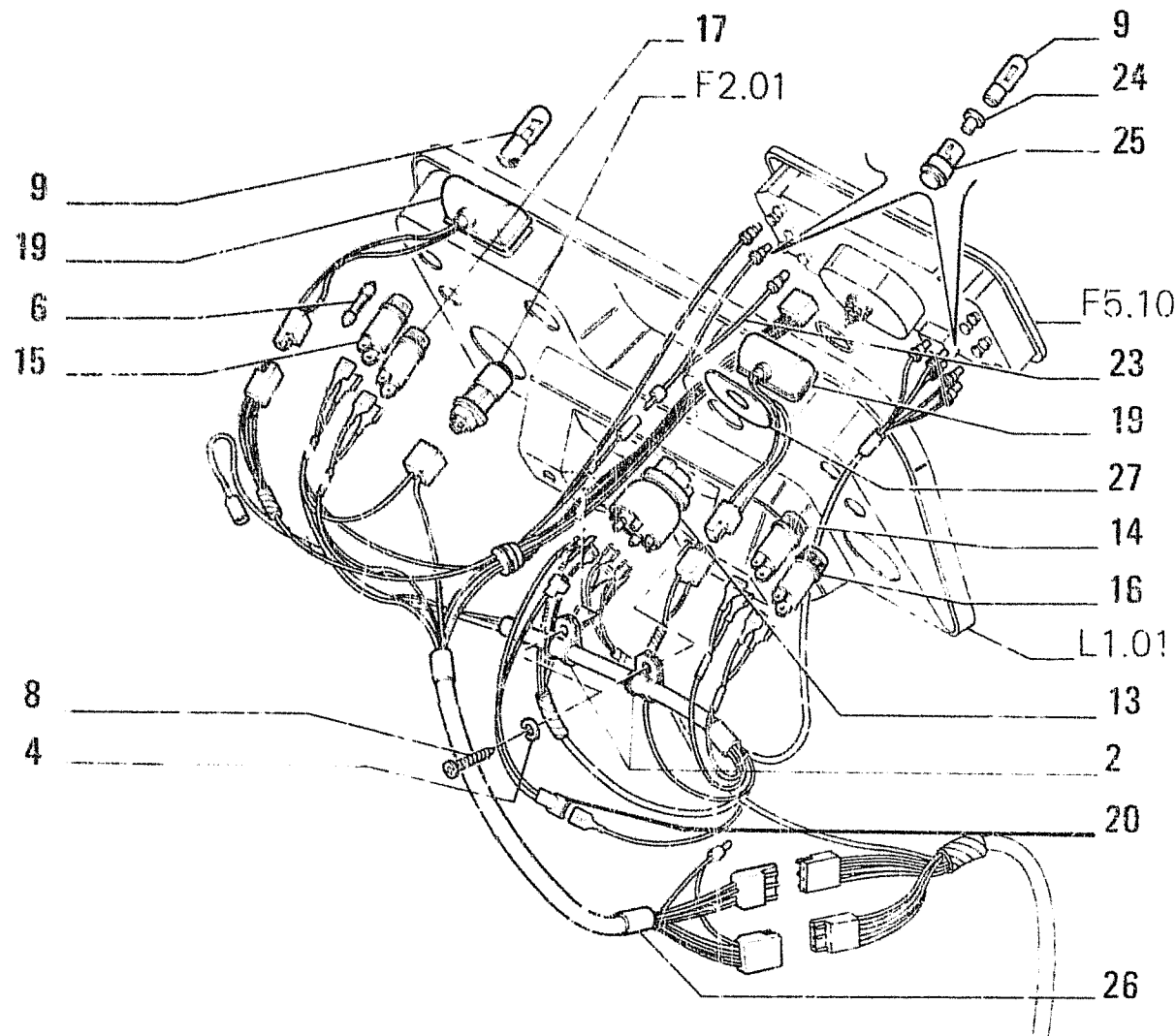

ITEM	PART NUMBER	QTY	TRANS CODE	DESCRIPTION	DESCRIZIONE
2	10441590	2	231S	CLIP 16x7	STAFFETTA 16x7
4	10571571	2	132R	LOCKWASHER 6,1x1,6	ROSETTA DI SICUREZZA 6,1x1,6
6	11052090	4	110F	FUSE 6x25	FUSIBILE 6x25
8	13275811	2	40V	SCREW 6x1x8	VITE 6x1x8
9	14142490	10	30L	LAMP 9,15x8,8	LAMPADA 9,15x8,8
13	79006370	1	210C	SWITCH	COMMUTATORE
14	79011643	1	188P	FUSE HOLDER	PORTAFUSIBILE
15	79011645	1	188P	FUSE HOLDER	PORTAFUSIBILE
16	79011647	1	188P	FUSE HOLDER	PORTAFUSIBILE
17	79011649	1	188P	FUSE HOLDER	PORTAFUSIBILE
19	79032398	2	12F	INSTRUMENT LAMP	FANALE DEL CRUSCOTTO
20	79037299	1	111C	CABLE	CAVO
23	79042811	1	111C	CABLE	CAVO
24	79042812	8	60C	WIRE TERMINAL	CAPOCORDA
25	79042813	8	193P	BULB HOLDER	PORTALAMPADA
26	76010396	1	111C	CABLE	CAVO
27	79043274	1	65T	DECAL	TARGA

D 2837 Tel.n. 251333 -

LIGHTING SYSTEM - ILLUMINAZIONE - ECLAIRAGE - BELEUCHTUNG - SISTEMA DE ALUMBRADO

2

F4.01/A

1

N.T.R. 191 - 20.02.1990

604.01.081.04

T14

211

ELECTRICAL SYSTEM
IMPIANTO ELETTRICO

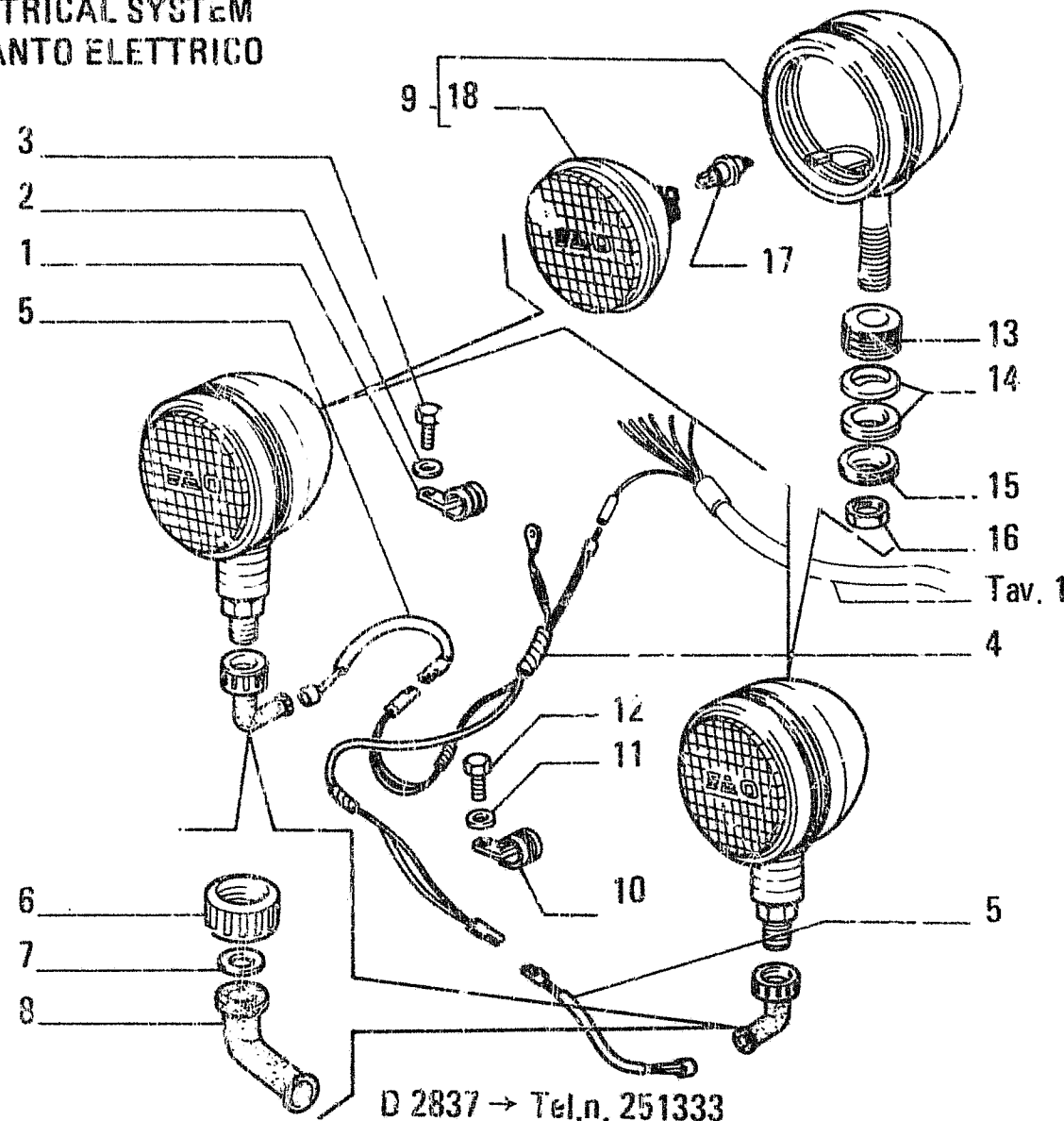

FIATALLIS FD7

F4.01/ A TAV. 2 PAG.1

ITEM	PART NUMBER	QTY	TRANS CODE	DESCRIPTION	DESCRIZIONE
1	10450090	1	231S	CLIP 8x9	STAFFETTA 8x9
2	10571771	1	170R	LOCKWASHER 8,1x2	ROSETTA 'L. 8,1x2
3	16043031	1	40V	SCREW 6x1,25x12	VITE 6x1,25x12
4	76014252	1	111C	CABLE	CAVO
5	76014253	2	111C	CABLE	CAVO
6	79069895	2	50G	RING NUT	GHIRRA
7	79069896	2	131G	WASHER	ROSETTA
8	79070321	2	120G	GASKET	GUARNIZIONE PIANA
9	79073819	2	220P	FLOODLIGHT - ASSEMBLY	PROIETTORE - COMPLETO
10	10441190	2	231S	CLIP 52x7 D3267	STAFFETTA 52x7 D3267
11	10571571	2	170R	LOCKWASHER 6,1x1,6 D3267	ROSETTA EL. 6,1x1,6 D3267
12	10902031	2	40V	SCREW 6x1x12 D3267	VITE 6x1x12 D3267
13	79073822	1	75D	SPACER	DISTANZIALE
14	79073823	2	60T	BLOCK	TASSELLO
15	79073824	1	131R	WASHER	ROSETTA
16	79073825	1	10D	NUT	DAITO
17	79069460	1	30L	LAMP	LAMPADA
18	79080111	1	171R	REFLECTOR	RIFLETTORE

LIGHTING SYSTEM - ILLUMINAZIONE - ECLAIRAGE - BELEUCHTUNG - SISTEMA DE ALUMBRADO

F4.01/A 2

M.T.R. 200 - 15.10.1990

604.01.031.05

T15

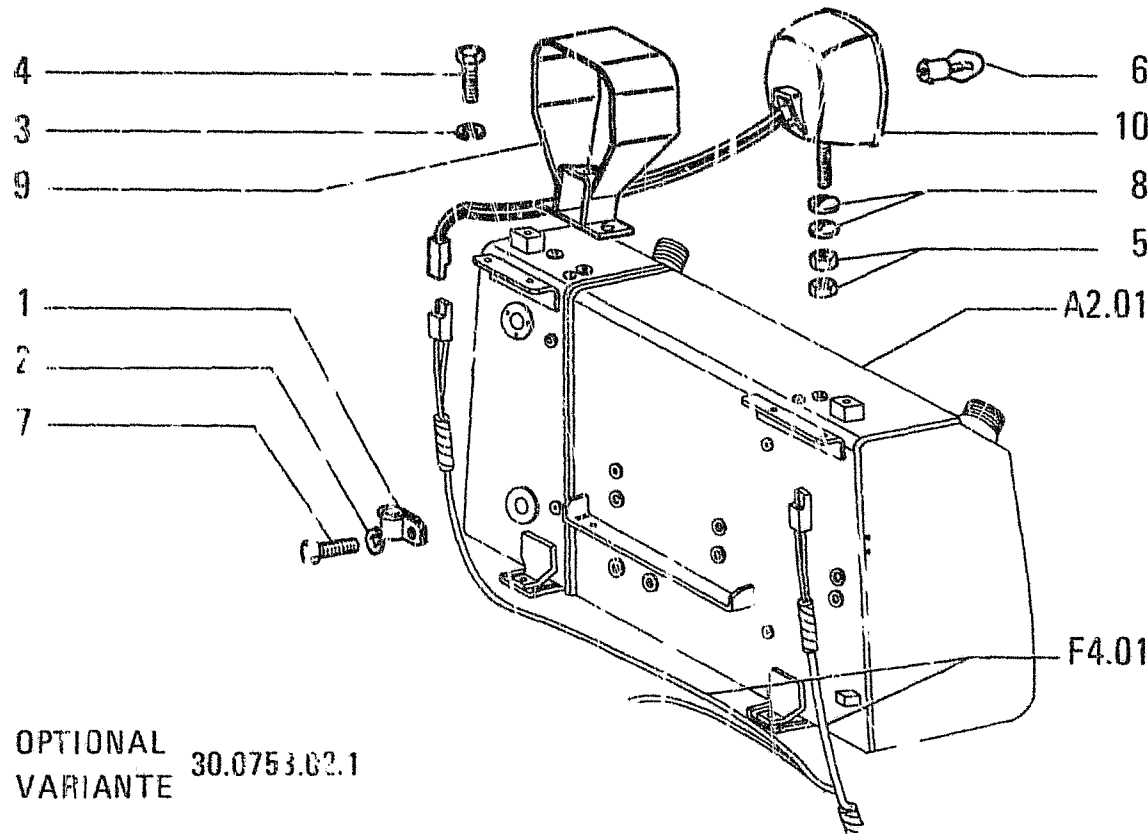

OPTIONAL
VARIANTE 30.0753.02.1

C 2837 → Tel.n. 251332

J T E M	PART NUMBER	Q T Y	TRANS CODE	DESCRIPTION	DESCRIZIONE
1	10449890	1	225S	BRACKET 6x9	STAFFA 6x9
2	10571571	1	132R	LOCKWASHER 6,1x1,6	ROSETTA DI SICUREZZA 6,1x1,6
3	10571871	2	132R	LOCKWASHER 10,2x2,2	ROSETTA DI SICUREZZA 10,2x2,2
4	11106231	2	40V	SCREW 10x1,5x25	VITE 10x1,5x25
5	11702921	2	10P	NUT 12x1,75x10	DADO 12x1,75x10
6	14142690	1	30L	LAMP 20x35,5	LAMPADA 20x35,5
7	16043031	1	40V	SCREW 8x1,25x12	VITE 8x1,25x12
8	76000905	2	60T	BLOCK - IN ALTERNATIVE	TASSELLO - IN ALTERNATIVA
	79003030	2	60T	BLOCK - IN ALTERNATIVE	TASSELLO - IN ALTERNATIVA
9	79025861	1	300S	SUPPORT	SUPPORTO
10	79032396	1	220P	FLOODLIGHT - ASSEMBLY SEE SGR. F4.05	PROIETTORE - COMPLETO VEDERE SGR. F4.05

LIGHTING SYSTEM -- ILLUMINAZIONE -- ECLAIRAGE -- BELEUCHTUNG -- SISTEMA DE ALUMBRADO

F4.01/1

N.T.R. 191 - 20.02.1990

604.01.081.04

REAR SPOT LAMP
PROIETTORE POSTERIORE

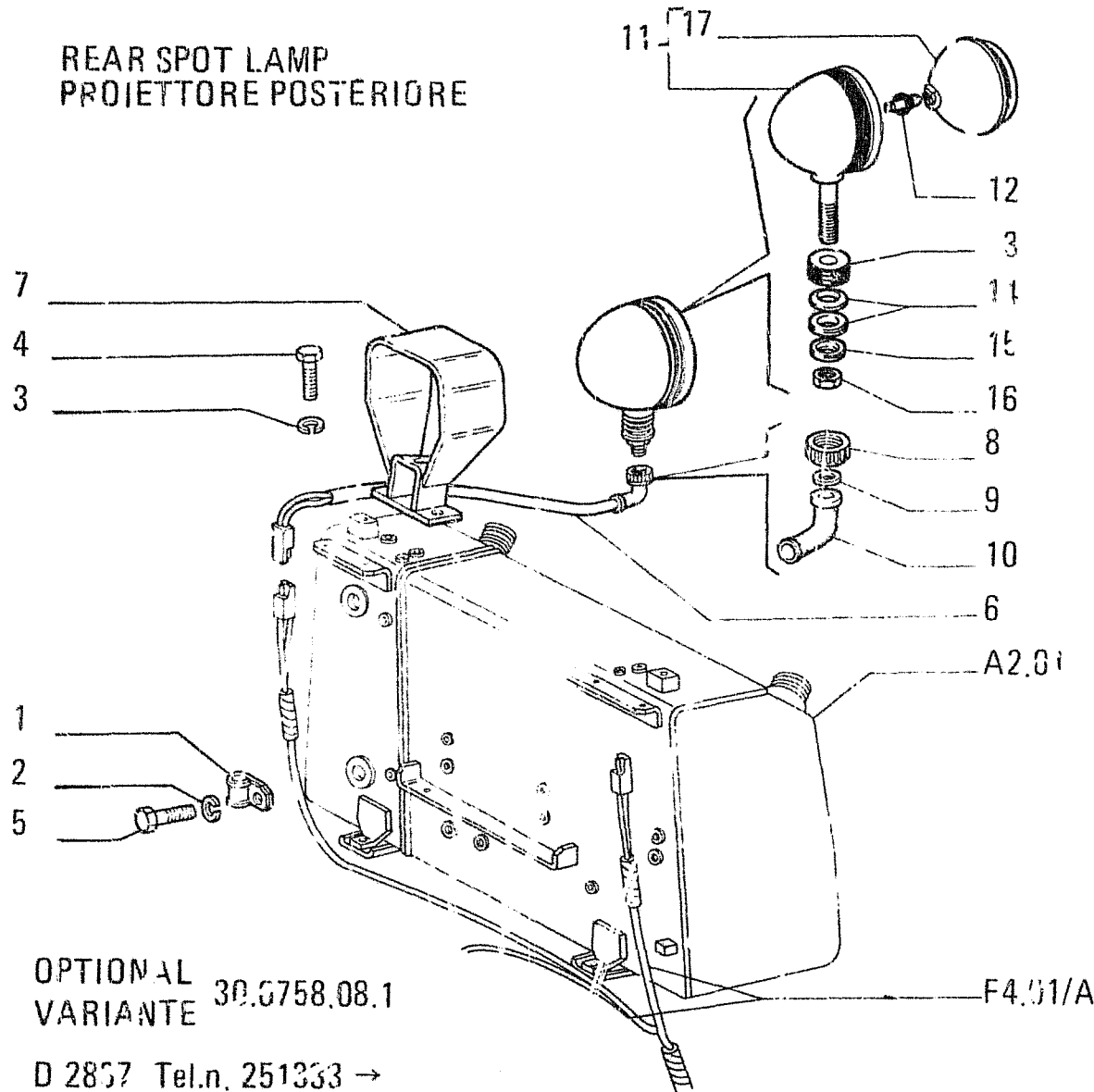

OPTIONAL
VARIANTE 30.0758.08.1

D 2857 Tel.n. 251333 →

ITEM	PART NUMBER	QTY	TRANS. CODE	DESCRIPTIO.	DESCRIZIONE
1	10449890	1	225S	BRACKET 6x9	STAFFA 6x9
2	10517071	1	170C	LOCKWASHER 12,2x3,1	ROSETTA EL. 12,2x3,1
3	10571571	2	132R	LOCKWASHER 6,1x1,6	ROSETTA DI SICUREZZA 6,1x1,6
4	11106231	2	40V	SCREW 10x1,5x25	VITE 10x1,5x25
5	16043031	1	40V	SCREW 8x1,25x12	VITE 8x1,25x12
6	76013804	1	111C	CABLE	CAVO
7	76014422	1	303S	SUPPORT	SUPPORTO
8	79069895	1	50G	RING NUT	GHIERA
9	79069896	1	131R	WASHER	ROSETTA
10	79070321	1	120G	GASKET	GUARNIZIONE FINA
11	79073819	1	220P	FLOODLIGHT - ASSEMBLY	PROIETTORE - COMPLETO
12	79069460	1	30L	LAMP	LAMPADA
13	79073822	1	75D	SPACER	DISTANZIALE
14	79073823	2	60T	BLOCK	TASSELLO
15	79073824	1	131R	WASHER	ROSETTA
16	79073825	1	10D	NUT	DADO
17	79030111	1	171R	REFLECTOR	RIFLETTORE

LIGHTING SYSTEM - ILLUMINAZIONE - ECLAIRAGE - BELEUCHTUNG - SISTEMA DE ALUMBRADO

F4.01/1A

N.T.R. 200 - 15.10.1990

604.01.081.05

F	ELECTRICAL SYSTEM • IMPIANTO ELETTRICO • SYSTEME ELECTRIQUE • ELEKTRISCHE ANLAGE • SISTEMA ELETTRICO
H	TOOLS • ATTREZZI • OUTILLAGES • WERKZEUGE • UTILES
L	BODY • CARROZZERIA • CARROSSERIE • AUFBAU • CARROCERIA

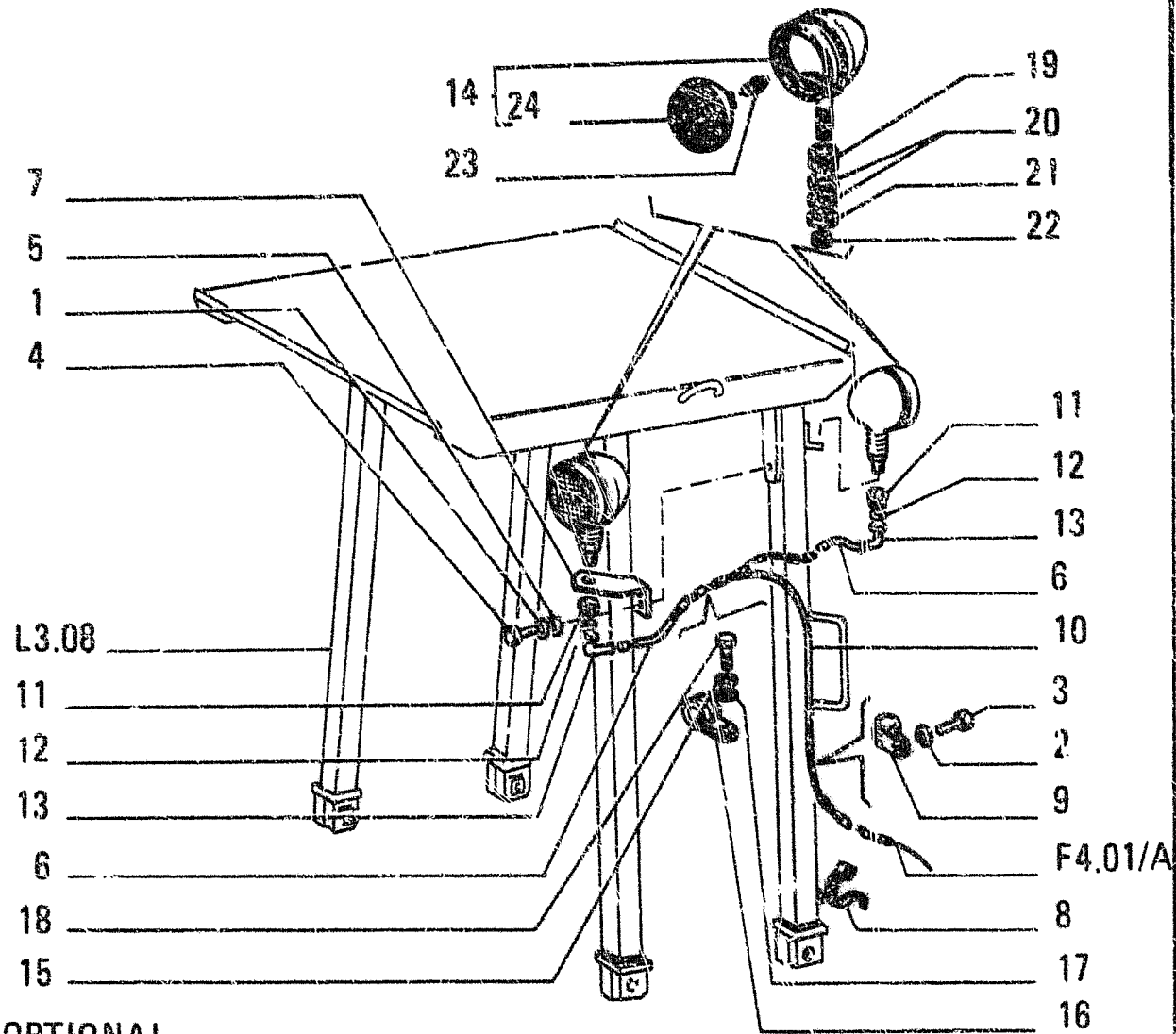

I T E M	PART NUMBER	Q T Y	TRANS CODE	DESCRIPTION	DESCRIZIONE
22	79073825	1	10D NUT		DADO
23	79069460	1	30L LAMP		LAMPADA
24	79080111	1	171R REFLECTOR		RIFLETTORE

OPTIONAL
VARIANTE 30.0765.05.1

D 2837 Tel.n. 251333 →

LICHTING SYSTEM - ILLUMINAZIONE - ECLAIRAGE - BELEUCHTUNG - SISTEMA DE ALUMBRADO

F4.01/2A

N.T.R. 200 - 15.10.1990

604.01.081.05

H2

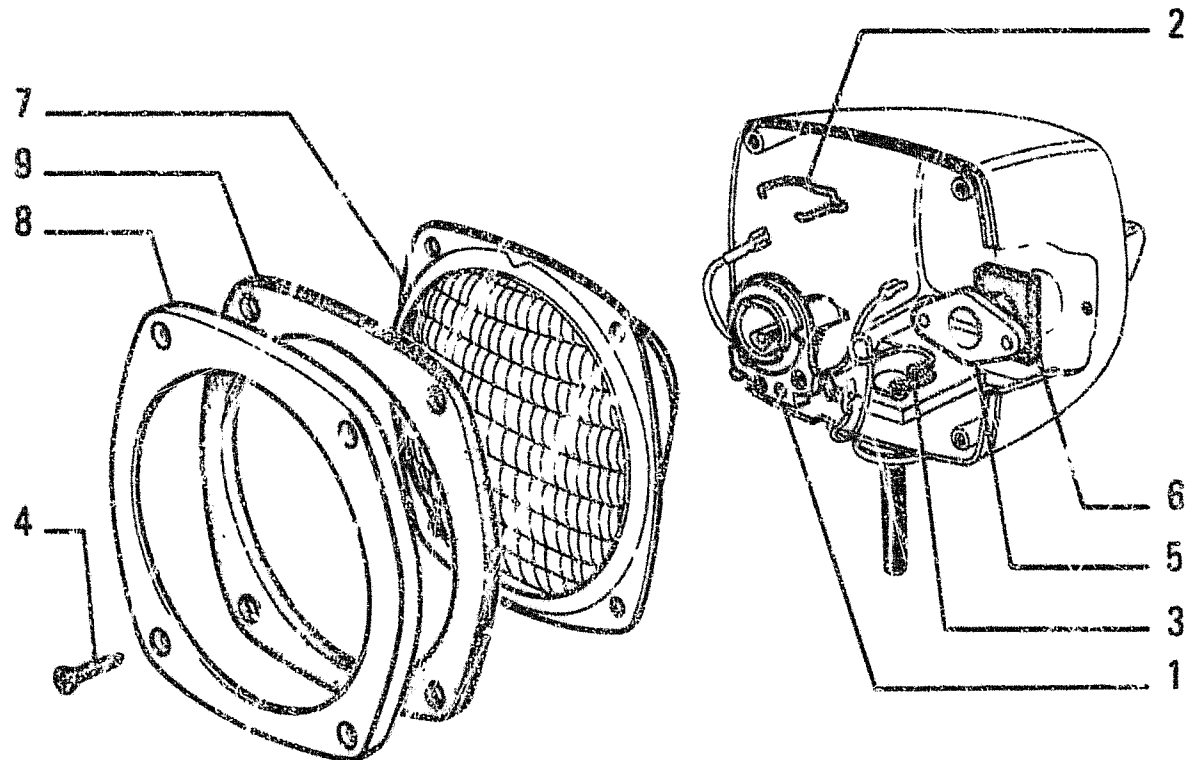

ITEM	PART NUMBER	QTY	TRANS CODE	DESCRIPTION	DESCRIZIONE
1	9918431	1	193P	BULB HOLDER - DELATED	PORTALAMPADA - ELIMINATO
2	9927292	1	45F	CLIP - DELATED	FERMAGLIO - ELIMINATO
3	15642601	2	40V	SCREW - DELATED 3,5x13	VITE - ELIMINATO 3,5x13
4	15662001	4	40V	SCREW - DELATED 3,5x19	VITE - ELIMINATO 3,5x19
5	79012035	1	75B	CONNECTOR - DELATED	BLOCCHETTO CONNESSIONE - ELIMINATO
6	79012036	1	123G	SEAL ASSY - DELATED	GUARNIZIONE TENUTA FRONTALE - ELIMINATO
7	79013412	1	110G	LENS/REFLECTOR UNIT	GRIPPO OTTICO
8	79013413	1	295C	BEZEL - DELATED	CORNICE - ELIMINATO
9	79013414	1	123G	SEAL ASSY - DELATED	GUARNIZIONE TENUTA FRONTALE - ELIMINATO

C 2837 - Tel.n. 251332

79032396 (Olsa)

HEADLAMP - PROIETTORE - PROJECTEUR - SCHEINWERFER - PROYECTOR

H3

F4.05

N.T.R. 191 - 20.02.1990

604.01.081.04

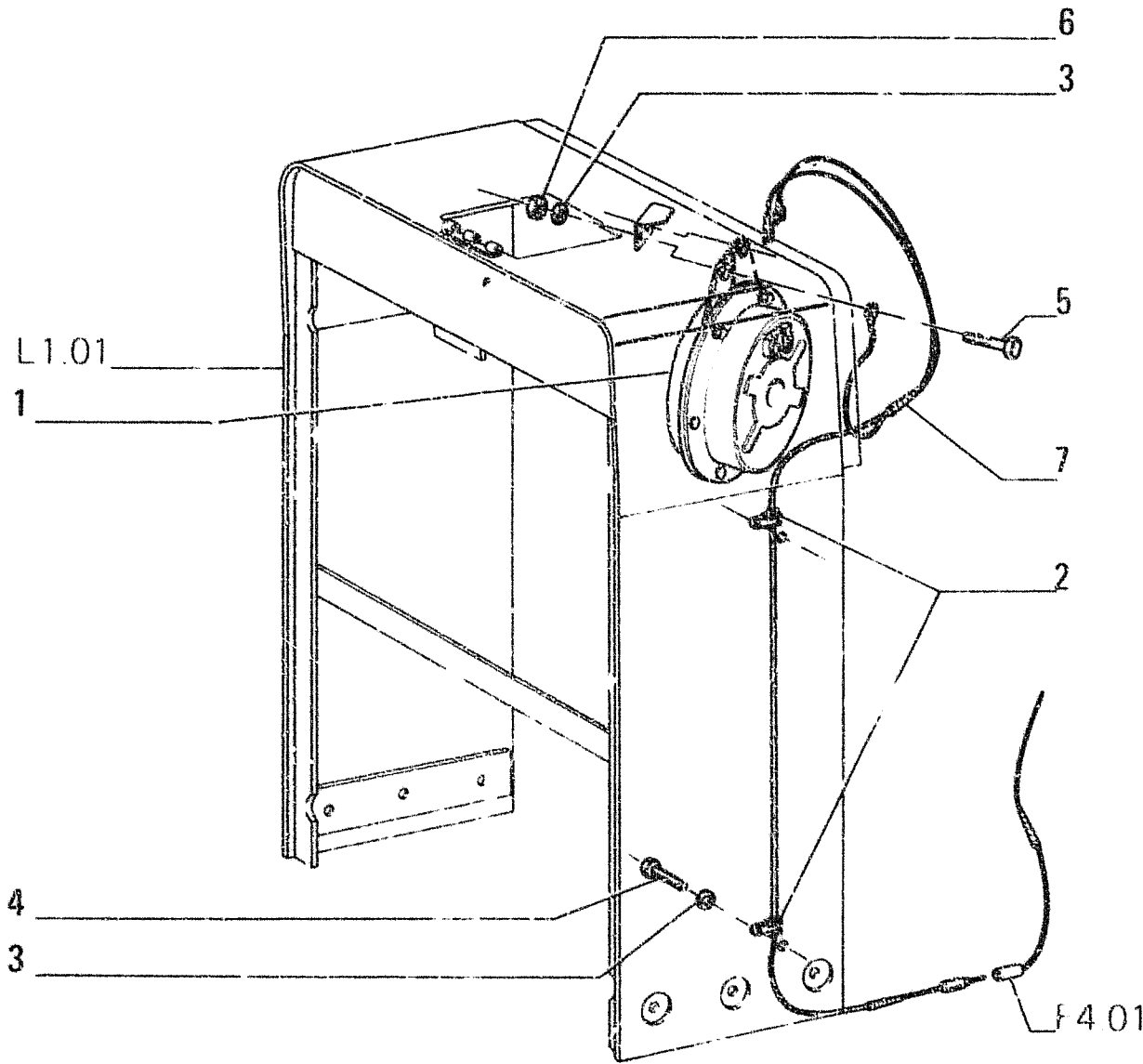

ITEM	PART NUMBER	QTY	TRANS CODE	DESCRIPTION	DESCRIZIONE
1	4238805	1	105A HORN C1524		AVVISATORE ACUSTICO C1524
	79056873	1	105A HORN D1524		AVVISATORE ACUSTICO D1524
2	10440990	2	231S CLIP 6x7		STAFFETTA 6x7
3	10571771	4	132R LOCKWASHER 8,1x2		ROSETTA DI SICUREZZA 8 1x2
4	10979421	2	40V SCREW 6x1x10		VITE 6x1x10
5	16043631	2	40V SCREW 8x1,25x25		VITE 8x1,25x25
6	16100821	2	10D NUT 8x1,25x6,5		DADO 8x1,25x6,5
7	79031741	1	111C CABLE		CAVO

SIGNALLING DEVICES - SEGNALAZIONI DI AVVISO - AVERTISSEURS -
 SIGNALISIERVORRICHTUNGEN - SENALIZACION DE AVISO

2

F5.01

N.T.R. 191 - 20.07.1990
 604.01.081.04

H4

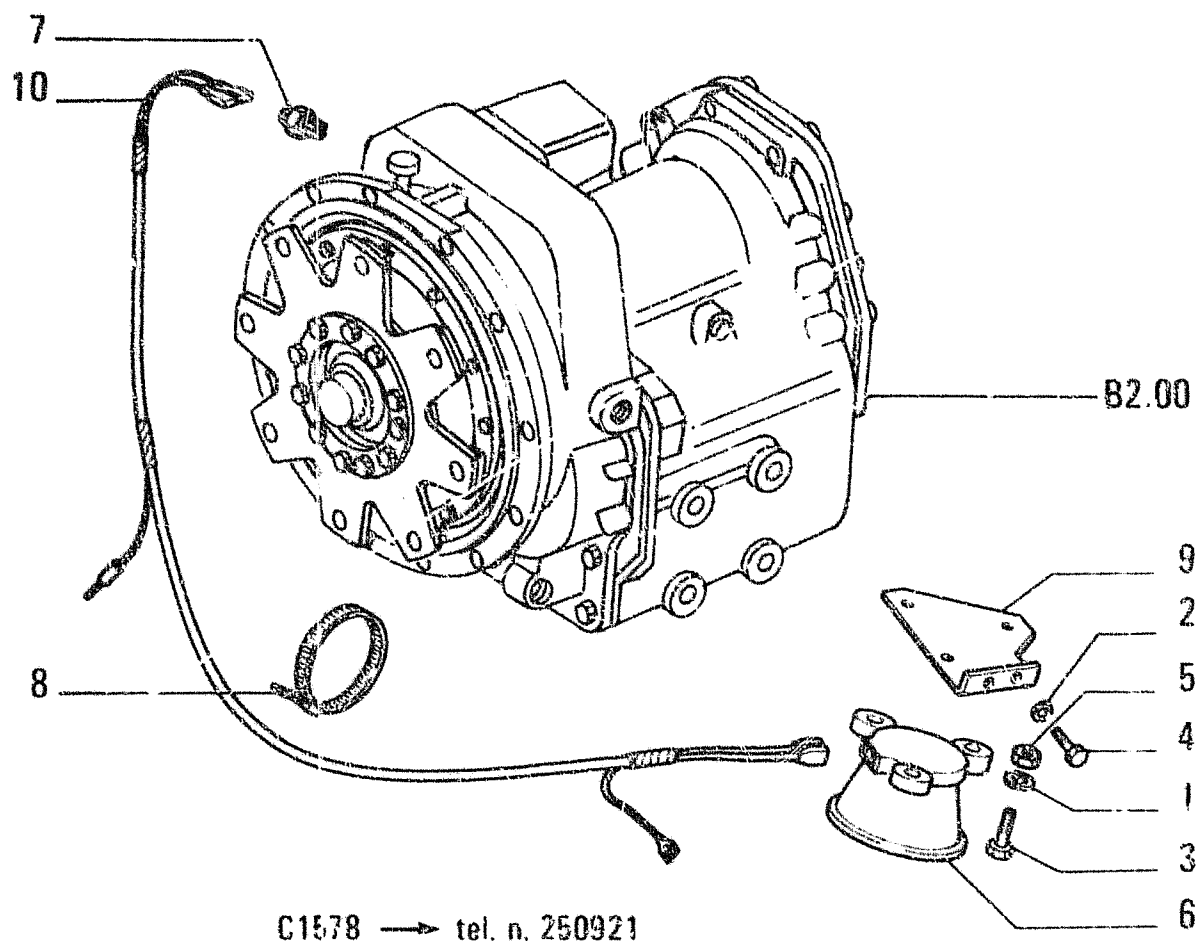

ITEM	PART NUMBER	QTY	TRANS CODE	DESCRIPTION	DESCRIZIONE
1	10571571	3	131R	WASHER (*) (1") 6,1x1,6	ROSETTA (*) (1") 6,1x1,6
2	10571871	2	131R	WASHER (*) (1") 10,2x2,2	ROSETTA (*) (1") 10,2x2,2
3	10902821	3	40V	SCREW (*) (1") 6x1x30	VITE (*) (1") 6x1x30
4	11106231	2	40V	SCREW (*) (1") 10x1,5x25	VITE (*) (1") 10x1,5x25
5	15896211	3	10D	NUT (*) (1") 6x1x5	DADO (*) (1") 6x1x5
6	70699053	1	105A	HORN (1")	AVVISATORE ACUSTICO (1")
7	79012600	1	7SI	SWITCH (*) (1")	INTERRUTTORE (*) (1")
8	79013422	1	31F	CLAMP (*) (1")	FASCETTA (*) (1")
9	79038360	1	300S	SUPPORT (*) (1")	SUPPORTO (*) (1")
10	79045350	1	111C	CABLE - CORRECT (*) (1")	CAVO - CORRIGE (*) (1")
	79045846	1	111C	CABLE - WRONG (*) (1")	CAVO - ERRATA (*) (1")
(*)			469P	FOR SPECIAL EQUIPMENT 30.0759.11.1	PER VARIANTE 30.0759.11.1
(1")			469P	FOR SPECIAL EQUIPMENT 30.0760.11.1	PER VARIANTE 30.0760.11.1

SIGNALLING DEVICES - SEGNALAZIONI DI AVVISO - AVERTISSEURS - SIGNALISIERVORRICHTUNGEN - 2
 SENALIZACION DE AVISO

H5

F5.01/1
 N.T.R. 158 - 13.03.1987
 604.01.081.03

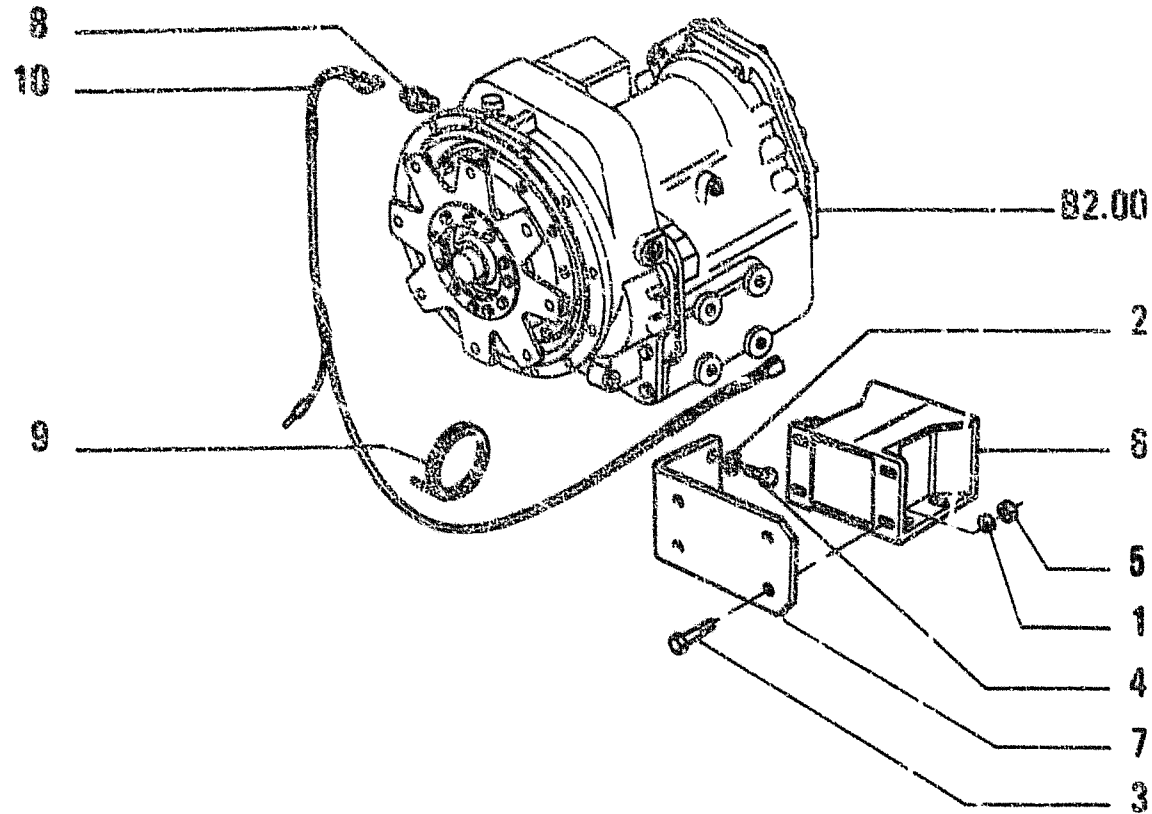

D1578 tel. n. 250922 →

ITEM	PART NUMBER	QTY	TRANS CODE	DESCRIPTION	DESCRIZIONE
1	10571571	4	131R	WASHER (*) (1") 6,1x1,6	ROSETTA (*) (1") 6,1x1,6
2	10571871	2	131R	WASHER (*) (1") 10,2x2,2	ROSETTA (*) (1") 10,2x2,2
3	10902421	4	40V	SCREW (*) (1") 6x1x20	VITE (*) (1") 6x1x20
4	11109231	2	40V	SCREW (*) (1") 10x1,5x25	VITE (*) (1") 10x1,5x25
5	15890211	4	100	NUT (*) (1") 6x1x5	DADO (*) (1") 6x1x5
6	73131988	1	105A	HORN (1")	AVVISATORE ACUSTICO (1")
7	76000588	1	300S	SUPPORT (*) (1")	SUPPORTO (*) (1")
8	79012600	1	75I	SWITCH (*) (1")	INTERRUTTORE (*) (1")
9	79013422	1	31F	CLAMP (*) (1")	FASCETTA (*) (1")
10	79045350	1	111C	CABLE (*) (1")	CAVO (*) (1")
(*)			463P	FOR SPECIAL EQUIPMENT 30.0759.11.1	PER VARIANTE 30.0759.11.1
(1")			463P	FOR SPECIAL EQUIPMENT 30.0760.11.1	PER VARIANTE 30.0760.11.1

SIGNALLING DEVICES - SEGNALAZIONI DI AVVISO - AVERTISSEURS - SIGNALISIERVORRICHTUNGEN -- ²
SEÑALIZACION DE AVISO

F5.01/1A

M.T.F. 158 - 13.03.1987

004.01.081 03

H6

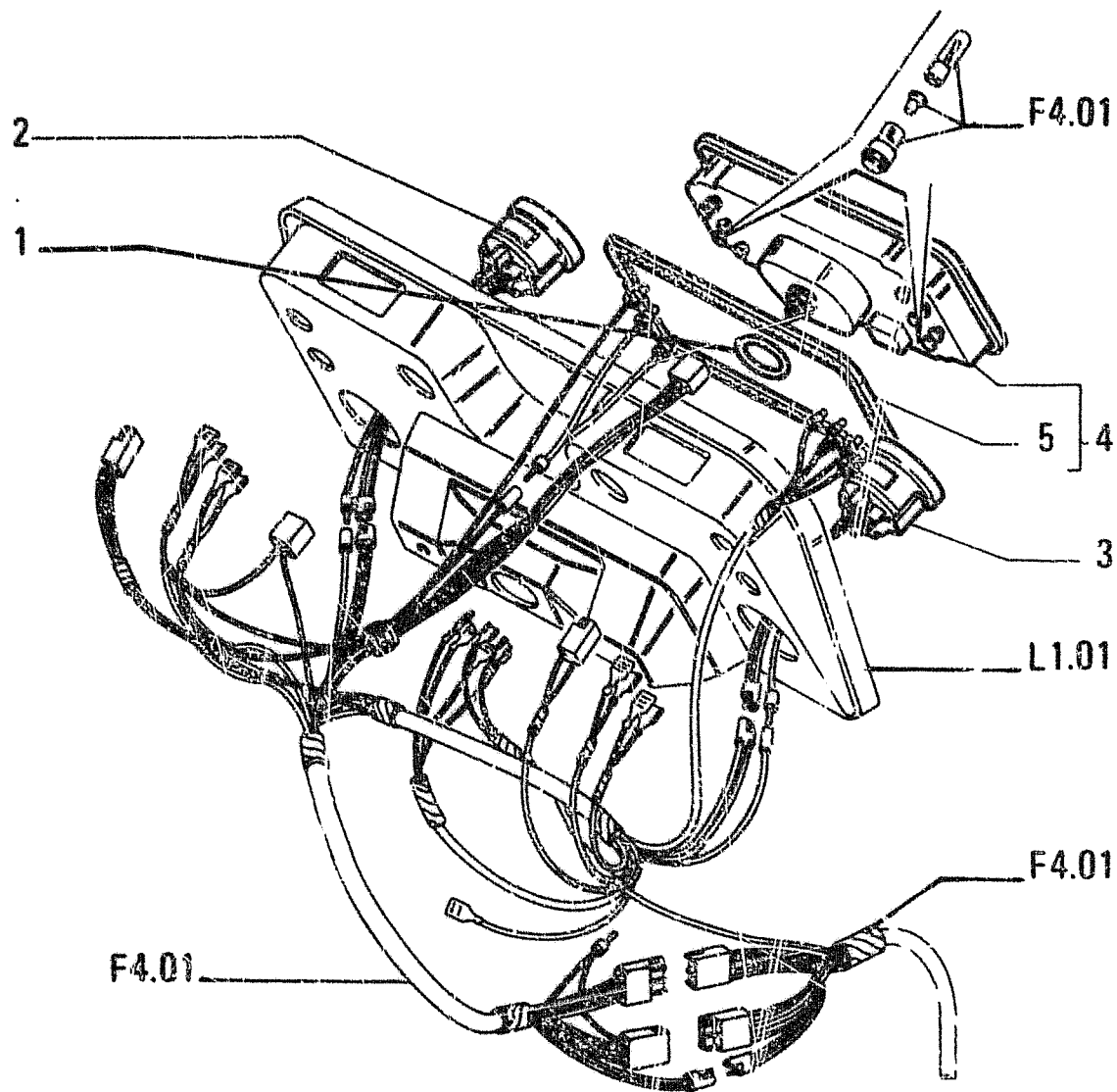

ITEM	PART NUMBER	QTY	TRANS CODE	DESCRIPTION	DESCRIZIONE
1	14471480	1	158G	O-RING 5,33x56,52 C1525	GUARNIZIONE O-R 5,33x56,52 C1525
2	79022774	1	42M	OIL PRESSURE GAUGE TRANSMISSION C1510	MANOMETRO OLIO TRANSMISSION C1510
	79051194	1	42M	OIL PRESSURE GAUGE TRANSMISSION D1510	MANOMETRO OLIO TRANSMISSION D1510
3	79028289	1	42M	OIL PRESSURE GAUGE ENGINE C1510	MANOMETRO OLIO ENGINE C1510
	79051200	1	42M	OIL PRESSURE GAUGE ENGINE D1510	MANOMETRO OLIO ENGINE D1510
4	79042633	1	288S	INSTRUMENT CLUSTER - ASSEMBLY C1525	STRUMENTO MULTIPLO - COMPLETO C1525
	79054141	1	288S	INSTRUMENT CLUSTER - ASSEMBLY D1525	STRUMENTO MULTIPLO - COMPLETO D1525
5	79037810	1	120G	GASKET C1525	GUARNIZIONE PIANA C1525
	79054137	1	120G	GASKET D1525	GUARNIZIONE PIANA D1525

OPERATION INDICATORS - SEGNALAZIONI DI FUNZIONAMENTO - TEMOINS DE FONCTIONNEMENT -
BETRIEBSSIGNALISIERUNG - TESTIGOS DE FUNCIONAMENTO

F5.10

N.T.R. 158 - 13.03.1987
604.01.081.03

H7

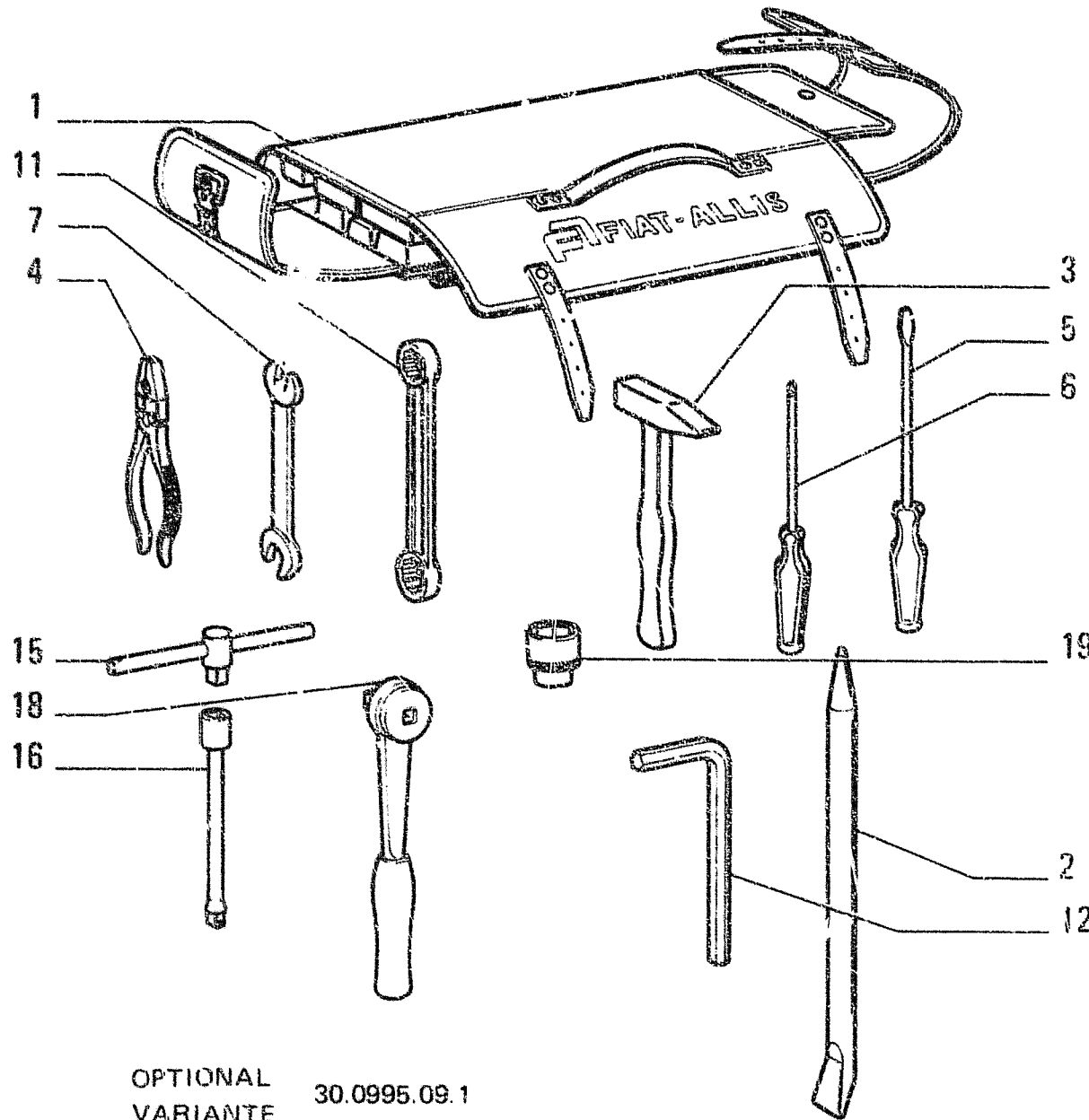

ITEM	PART NUMBER	QTY	TRANS. COLT.	DESCRIPTION	DESCRIZIONE
1	79028806	1	150B	BAG	BORSA
2	79028807	1	4JL	LEVER	LEVA
3	79028808	1	5IM	HAMMER	MARTELLO
4	79028809	1	1:5P	PLIERS	PINZA
5	79028810	1	10C	SCREWDRIVER	CACCIAVITE
6	79028811	1	10C	SCREWDRIVER	CACCIAVITE
7	79028812	1	150C	KEY 1X12	CHIAVE 1X12
	79028813	1	150C	KEY 13X17	CHIAVE 13X17
	79028814	1	150C	KEY 19X22	CHIAVE 19X22
	79028815	1	150C	KEY 24X27	CHIAVE 24X27
11	79028816	1	150C	KEY	CHIAVE
12	79028817	1	150C	KEY 8	CHIAVE 8
	79028818	1	150C	KEY 17	CHIAVE 17
	79028819	1	150C	KEY 24	CHIAVE 24
15	79028820	1	20M	HANDLE	MANIGLIA
16	79028821	1	222P	EXTENSION 75	PROLUNGA 75
	79028822	1	222P	EXTENSION 125	PROLUNGA 125
18	79028823	1	150C	KEY	CHIAVE
19	79028824	1	150C	KEY 10	CHIAVE 10
	79028825	1	150C	KEY 12	CHIAVE 12
	79028826	1	150C	KEY 13	CHIAVE 13
	79028827	1	150C	KEY 17	CHIAVE 17
	79028828	1	150C	KEY 19	CHIAVE 19
	79028829	1	150C	KEY 22	CHIAVE 22
	79028830	1	150C	KEY 24	CHIAVE 24
	79028831	1	150C	KEY 27	CHIAVE 27

OPTIONAL VARIANTE 30.0995.09.1

TOOLS - ATTREZZI - OUTILS - WERKZEUGE - HERRAMIENTAS

H1.01

1

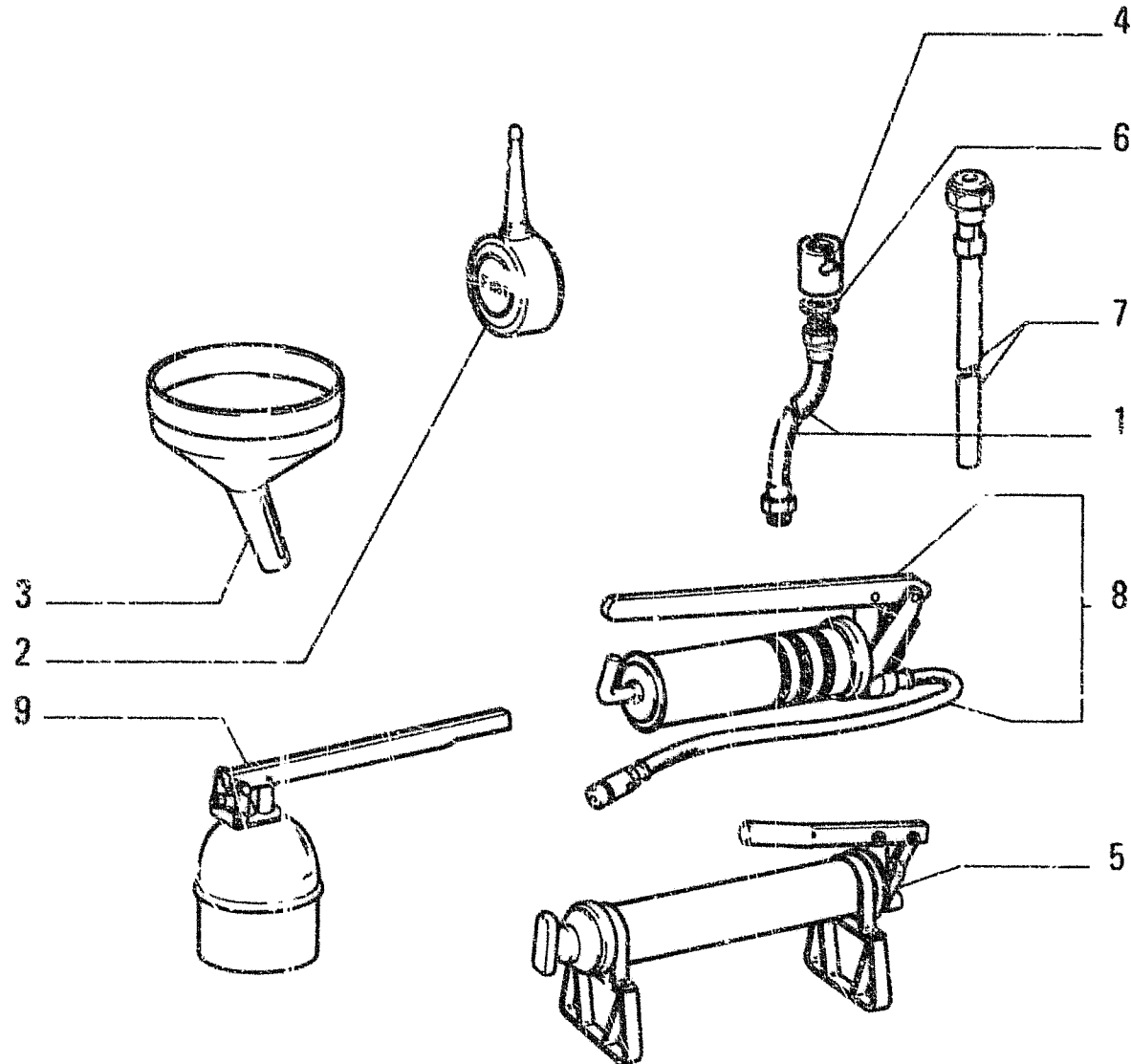

OPTIONAL
VARIANTE 30.0995.09.1

ITEM	PART NUMBER	QTY	TRANS CODE	DESCRIPTION	DESCRIZIONE
1	555486	1	192T	HOSE ASSY	TUBO FLESS.C./RACCORDI
2	591693	1	150	LUBE FITTING	OLIATORE
3	4057844	1	20I	FUNNEL	IMBUTO
4	4980622	1	119T	HEAD	TESTA
5	4981746	1	155P	PUMP	POMPA
6	10287380	2	133R	SEAL 12,2x18	ROSETTA DI TENUTA 12,2x18
7	79020961	1	192T	HOSE ASSY	TUBO FLESS.C./RACCORDI
8	79028979	1	155P	PUMP	POMPA
9	79030200	1	155P	PUMP	POMPA

TOOLS - ATTREZZI - OUTILS - WERKZEUGE - HERRAMIENTAS

H1.01 2

H9

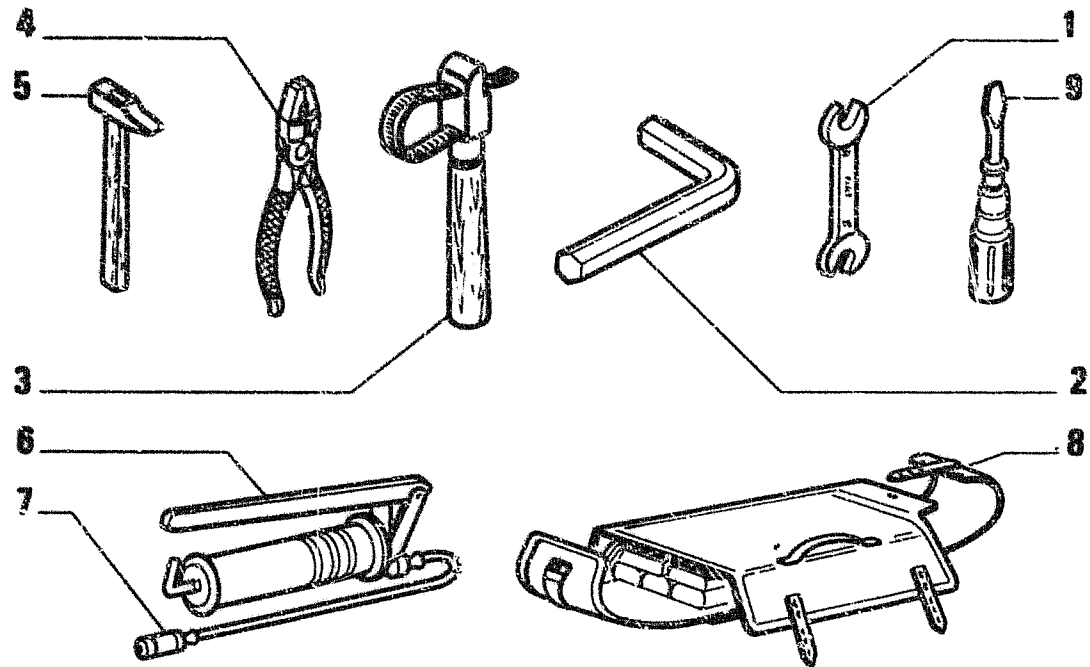

OPTIONAL
VARIANTE 30.0995.12.1

ITEM	PART NUMBER	QTY	TRANS CODE	DESCRIPTION	DESCRIZIONE
1	14522421	1	150C	KEY 13-17 13x17	CHIAVE 13-17 13x17
	14525021	1	150C	KEY 8-10 8x10	CHIAVE 8-10 8x10
	14549579	1	150C	KEY 12-14 12x14	CHIAVE 12-14 12x14
	14549879	1	150C	KEY 19-22 19x22	CHIAVE 19-22 19x22
	14550079	1	150C	KEY 24-27 24x27	CHIAVE 24-27 24x27
2	14625979	1	150C	KEY 12 12x132	CHIAVE 12 12x132
	14628079	1	150C	KEY 8	CHIAVE 8
	14638179	1	150C	KEY 10 10x118	CHIAVE 10 10x118
3	71304923	1	150C	KEY	CHIAVE
4	14626671	1	125P	PLIERS 13x190	PINZA 13x190
5	14582790	1	51M	HAMMER 118x315	MARTELLO 118x315
6	79028977	1	155P	PUMP - IN ALTERNATIVE	POMPA - IN ALTERNATIVA
	79028978	1	155P	PUMP - IN ALTERNATIVE	POMPA - IN ALTERNATIVA
	79028979	1	155P	PUMP - IN ALTERNATIVE	POMPA - IN ALTERNATIVA
	79028980	1	155P	PUMP - IN ALTERNATIVE	POMPA - IN ALTERNATIVA
7	79028981	1	285T	HOSE	TUBO FLESSIBILE
8	79062734	1	150B	BAG	BORSA
9	14626090	1	10C	SCREWDRIVER 4,5X80 4,5x177	CACCIAVITE 4,5X80 4,5x177
	14626290	1	10C	SCREWDRIVER 6X200 6,5x303	CACCIAVITE 6X200 6,5x303

TOOLS - ATTREZZI - OUTILS - WERKZEUGE - HERRAMIENTAS

H1.01/1

1

N.T.R. 158 - 13.03.1987
604.01.081.03

H10

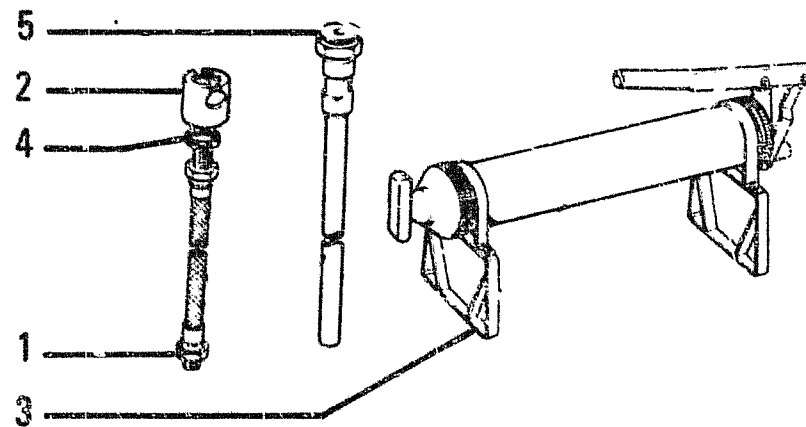

OPTIONAL
VARIANTE 30.0995.12.1

ITEM	PART NUMBER	QTY	TRANS CODE	DESCRIPTION	DESCRIZIONE
1	555486	1	192T	HOSE ASSY	TUBO FLESS.C/RACCORDI
	4983237	1	192T	HOSE ASSY	TUBO FLESS.C/RACCORDI
	79030434	1	192T	HOSE ASSY	TUBO FLESS.C/RACCORDI
2	549537	1	119T	HEAD	TESTA
	4980622	1	119T	HEAD	TESTA
3	582081	1	155P	PUMP - IN ALTERNATIVE	POMPA - IN ALTERNATIVA
	4955390	1	155P	PUMP - IN ALTERNATIVE	POMPA - IN ALTERNATIVA
	4981746	1	155P	PUMP - IN ALTERNATIVE	POMPA - IN ALTERNATIVA
	79030200	1	155P	PUMP - IN ALTERNATIVE	POMPA - IN ALTERNATIVA
4	10287380	2	120G	GASKET 12,2x18	GUARNIZIONE PIANA 12,2x18
5	592437	1	193T	TUBE	TUBO RIGIDO

TOOLS - ATTREZZI - OUTILS - WERKZEUGE - HERRAMIENTAS

H1.01/1

2

N.T.R. 158 - 13.03.1987

604.01.081.03

H11

ITEM	PART NUMBER	QTY	TRANS CODE	DESCRIPTION	DESCRIZIONE
1	14585678		150C	KEY 30x10	CHIAVE 30x10

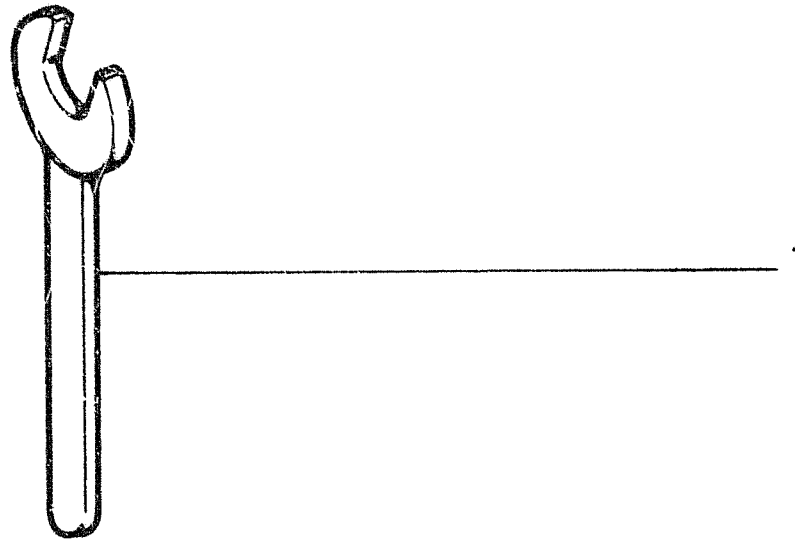

OPTIONAL 30.0405.03.1
 VARIANTE 30.0405.02.1

TOOLS - ATTREZZI - OUTILS - WERKZEUGE - HERRAMIENTAS

H1.01/2

N.T.R. 191 - 20 02.1990

604.01.081.04

H12

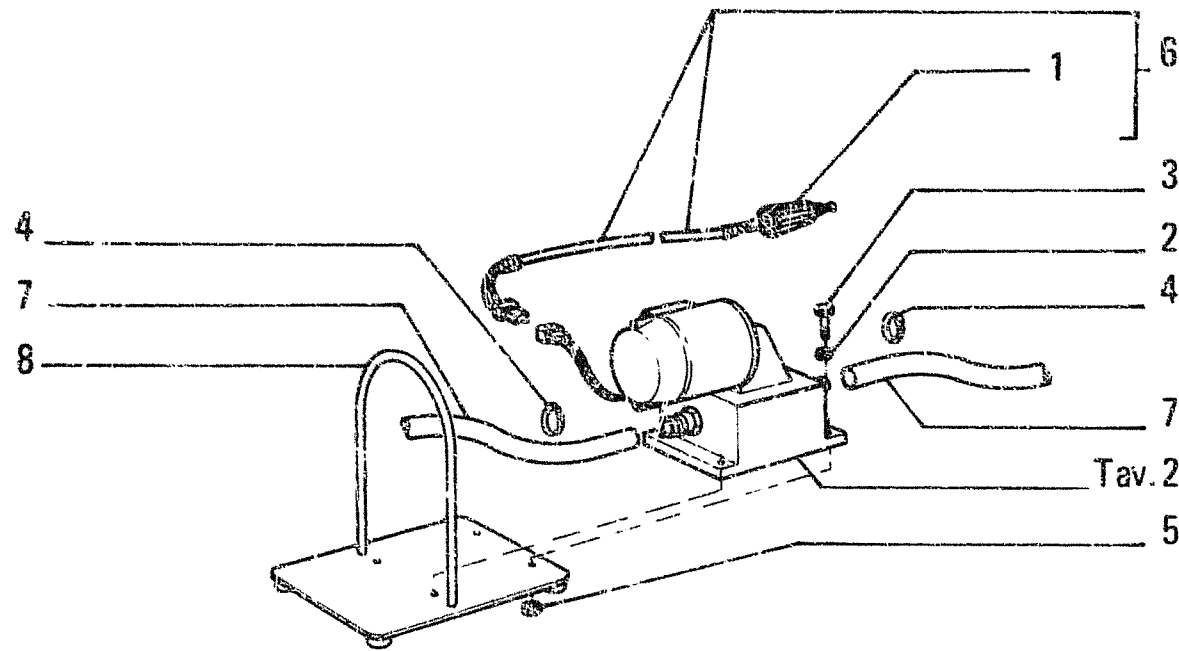

ITEM	PART NUMBER	QTY	TRANS CODE	DESCRIPTION	DESCRIZIONE
1	4182461	1	201S	ELECTRICAL PLUG	SPINA ELETTRICA
2	10516470	4	132R	LOCKWASHER 6,1x1,8	ROSETTA DI SICUREZZA 6,1x1,8
3	10902621	4	40V	SCREW 6x1x25	VITE 6x1x25
4	12173890	2	180C	COLLAR 24/36x14	COLLARE 24/36x14
5	15896211	4	10D	NUT 6x1x5	DADO 6x1x5
6	79013586	1	111C	CABLE - ASSEMBLY	CAVO - COMPLETO
7	79013500	2	193T	TUBE	TUBO RIGIDO
8	79013601	1	300S	SUPPORT	SUPPORTO

OPTIONAL VARIANTE 30.0993.02.1

ACCESSORIES - ACCESSORI - ACCESSOIRES - ZUBEHOER - ACCESORIOS

H1.04

1

H13

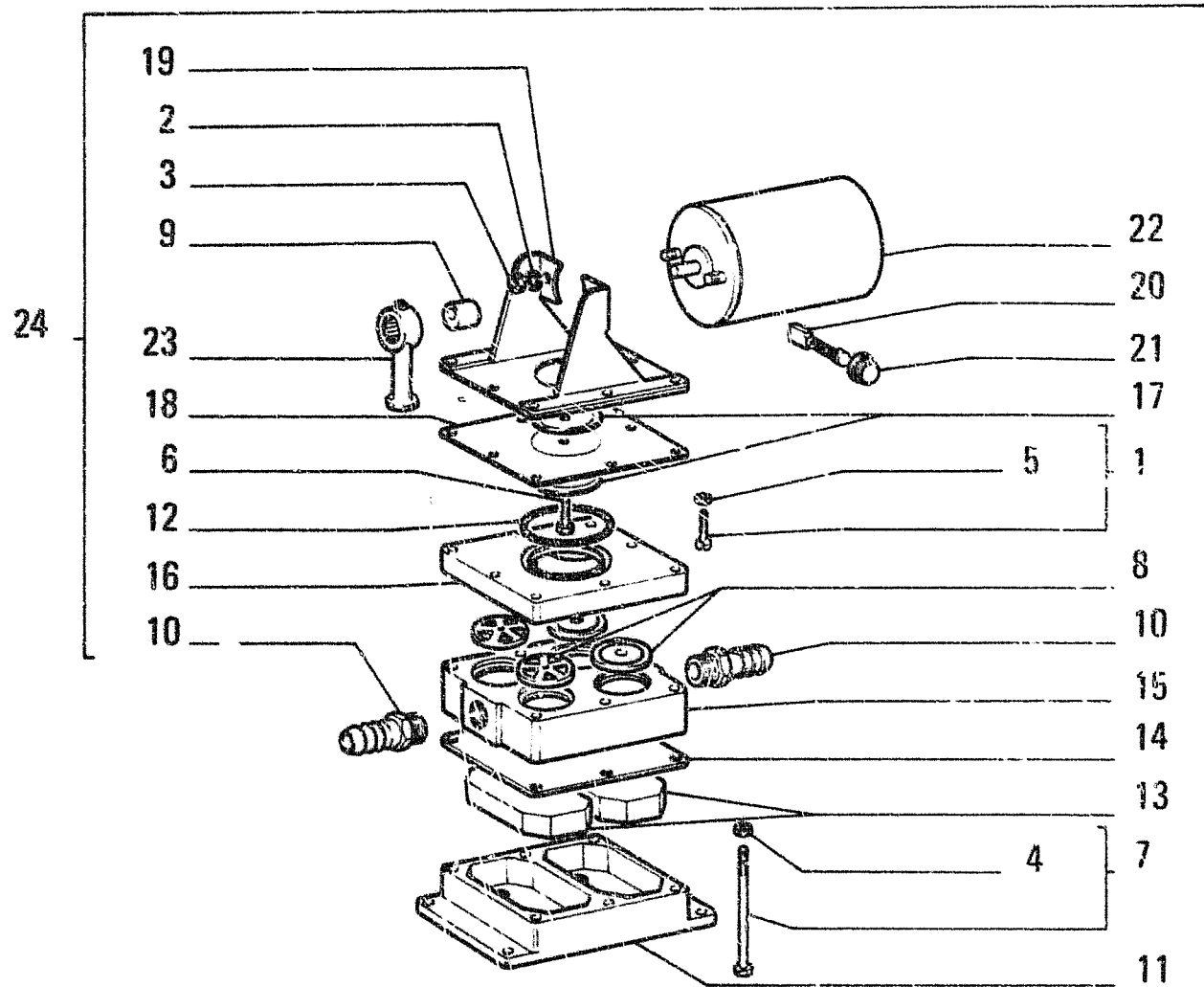

OPTIONAL
VARIANTE 30.0993.02.1

I T E M	PART NUMBER	Q T Y	TRANS CODE	DESCRIPTION	DESCRIZIONE
1	10352442	2	40V	SCREW - ASSEMBLY 4x0,7x25	VITE - COMPLETO 4x0,7x25
2	10516471	2	132R	LOCKWASHER 6,1x1,8	ROSETTA DI SICUREZZA 6,1x1,8
3	10725911	2	10D	NUT 6x1x4	DADO 6x1x4
4	10725940	6	10D	NUT 6x1x4	DADO 6x1x4
5	10794040	2	10D	NUT 4x0,7x3,2	DADO 4x0,7x3,2
6	10979440	1	40V	SCREW 6x1x10	VITE 6x1x10
7	16038540	6	40V	SCREW - ASSEMBLY 6x1x100	VITE - COMPLETO 6x1x100
8	45482314	2	10V	VALVE	VALVOLA
9	71304372	1	10E	ECCENTRIC	ECCENTRICO
10	71304373	2	20R	FITTING	RACCORDO
11	71304374	1	300C	BODY	CORPO
12	71304375	1	158G	O-RING	GUARNIZIONE O-R
13	71304376	2	235S	PISTON	STANTUFFO
14	71304377	1	75M	DIAPHRAGM	MEMBRANA
15	71304378	1	300C	BODY	CORPO
16	71304379	1	300C	BODY	CORPO
17	71304380	2	60D	DISC	DISCO
18	71304381	1	75M	DIAPHRAGM	MEMBRANA
19	71304385	1	300S	SUPPORT	SUPPORTO
20	71304386	2	177S	BRUSH	SPAZZOLA
21	71304387	2	265C	COVER	COPERCHIO
22	71304388	1	137M	ELECTRIC MOTOR	MOTORINO ELETTRICO
23	71304389	1	50B	LINK	BIELLA
24	79013599	1	31E	ELECTROPUMP - ASSEMBLY	ELETTROPOMPA - COMPLETO

ACCESSORIES - ACCESSORI - ACCESSOIRES - ZUBEHÖRER - ACCESORIOS

H1.04

2

H14

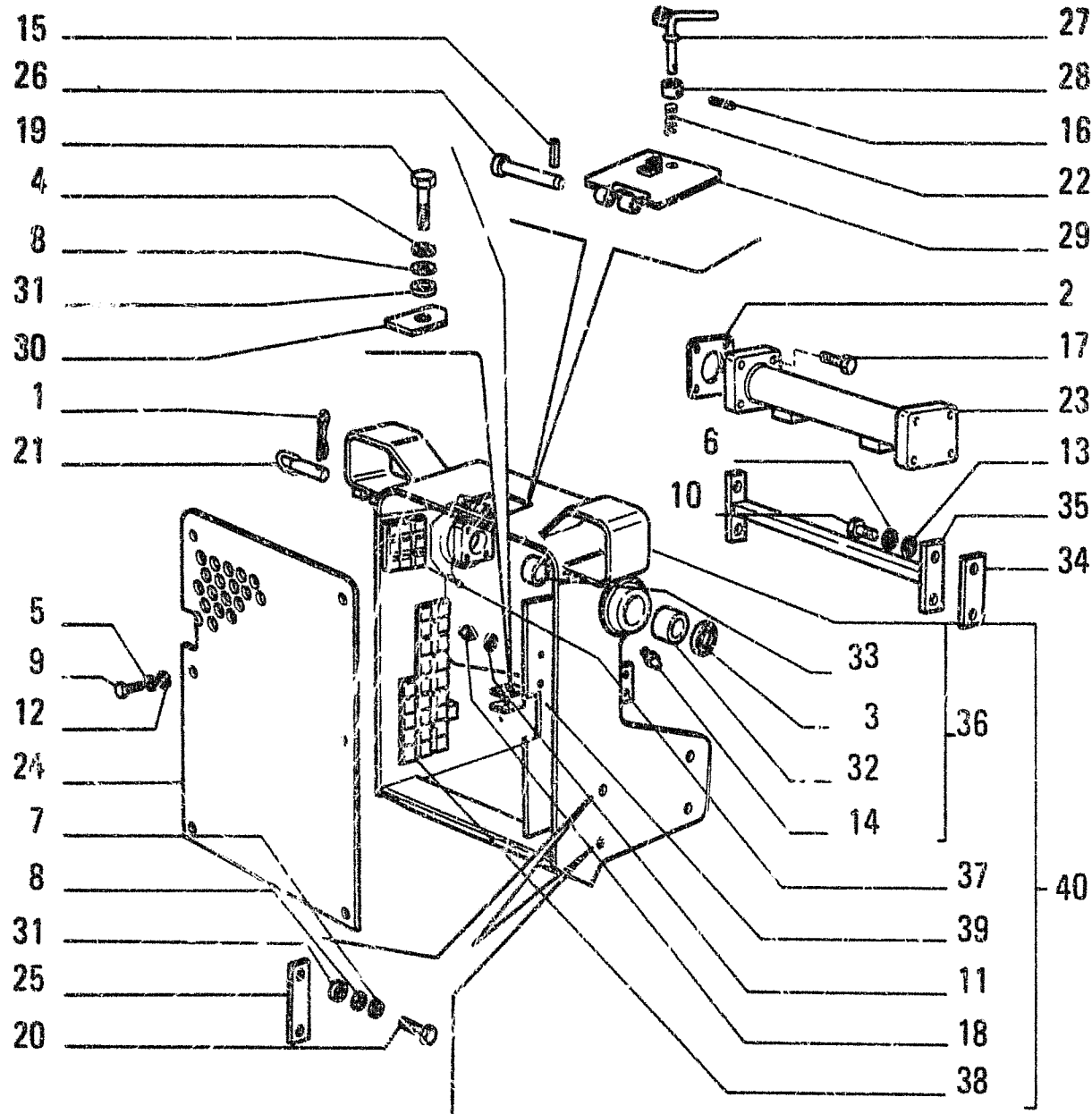

FIATALLIS FD7

ITEM	PART NUMBER	QTY	TRANS CODE	DESCRIPTION	DESCRIZIONE
1	567406	2	270C	COTTER PIN	COPIGLIA
2	4973384		198S	SHIM	SPESSORE
3	6291836	2	158G	O-RING	GUARNIZIONE O-R
4	10516471	4	132R	LOCKWASHER 6,1x1,8	ROSETTA DI SICUREZZA 6,1x1,8
5	10516871	6	132R	LOCKWASHER 10x2,5	ROSETTA DI SICUREZZA 10x2,5
6	10517071	4	132R	LOCKWASHER 12,2x3,1	ROSETTA DI SICUREZZA 12,2x3,1
7	10517471	8	132R	LOCKWASHER 20,2x4,5	ROSETTA DI SICUREZZA 20,2x4,5
8	10520421	12	131R	WASHER 20,4x35	ROSETTA 20,4x35
9	11106431	6	40V	SCREW 10x1,5x30	VITE 10x1,5x30
10	11112431	4	40V	SCREW 12x1,75x30	VITE 12x1,75x30
11	12642801	21	131R	WASHER (*) 4,15x12,5	ROSETTA (*) 4,15x12,5
12	12646821	6	131R	WASHER 10,2x25	ROSETTA 10,2x25
13	12646921	4	131R	WASHER 12,2x28	ROSETTA 12,2x28
14	13407211	2	60I	GREASE FITTING 10x1	INGRASSATORE 10x1
15	14161770	1	200S	PIN 3,3x16	SPINA 3,3x16
16	14163170	1	200S	PIN 4,4x24	SPINA 4,4x24
17	14258037	8	40V	SCREW 16x1,5x45	VITE 16x1,5x45
18	14642295	21	158G	O-RING (*) 2,3x15,7	GUARNIZIONE O-R (*) 2,3x15,7
19	15888931	4	40V	SCREW 14x2x120	VITE 14x2x120
20	15988431	8	40V	SCREW 20x1,5x65	VITE 20x1,5x65
21	79005781	2	81P	SECURING PIN	PERNO DI FISSAGGIO
22	79009016	1	100M	SPRING	MOLLA
23	79016843	1	180T	CROSS BEAM	TRAVERSA
24	79016845	1	70R	GUARD - FRONT	RIPARO - ANTERIORE
25	79017091		198S	SHIM	SPESSORE
26	79021009	1	80P	PIN	PERNO
27	79023984	1	20M	HANDLE	MANIGLIA

HOOD ASSY - COFANATURA - CAPOTAGE - HAUBE - CAPOT

L1.01 1

N.T.R. 158 - 13.03.1987
604.01.081.03

H15

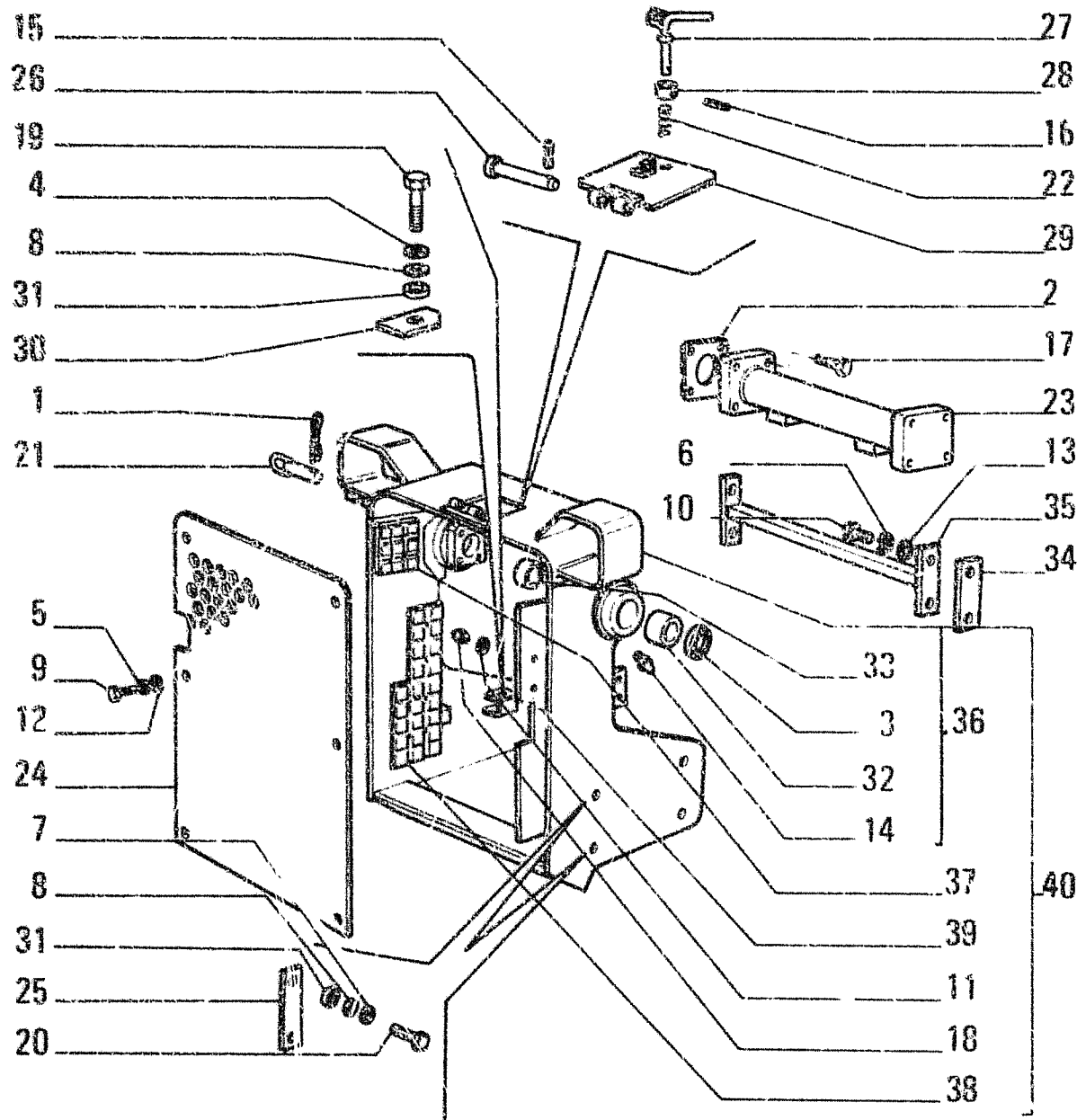

FIATALLIS PD7

L1.01 TAV. 1 PAG.2

ITEM	PART NUMBER	QTY	TRANS CODE	DESCRIPTION	DESCRIZIONE
26	79023986	1	45L	LEVER	LEVA
29	79024802	1	205S	DOOR	SPORTELLO
30	79027981		198S	SHIM	SPESSORE
	79027982		198S	SHIM	SPESSORE
	79027983		198S	SHIM	SPESSORE
31	79032222	12	131R	WASHER	ROSETTA
32	79035549	2	95B	BUSHING - OUTER	BOCCOLA - ESTERNO
33	79035550	2	95B	BUSHING - INNER	BOCCOLA - INTERNO
34	79037033		198S	SHIM	SPESSORE
35	79037578	1	180T	CROSS BEAM - FRONT	TRAVERSA - ANTERIORE
36	79034756	1	330C	RADIATOR GUARD - ASSEMBLY	CUFFIA RADIATORE - COMPLETO
37	79039522	1	25P	PANEL - UPPER RIGHT (*)	PANNELLO - SUPERIORE DESTRO (*)
38	79039523	1	25P	PANEL - LOWER RIGHT (*)	PANNELLO - INFERIORE DESTRO (*)
39	79039524	1	25P	PANEL - LEFT (*)	PANNELLO - SINISTRO (*)
40	79039521	1	330C	RADIATOR GUARD - ASSEMBLY (*)	CUFFIA RADIATORE - COMPLETO (*)
(*)			469P	FOR SPECIAL EQUIPMENT 30.0022.31.1	PER VARIANTE 30.0022.31.1

HOOD ASSY - COFANATURA - CAPOTAGE - HAUBE - CAPOT

L1.01

1

N.T.R. 158 - 13.03.1987
604.01.081.03

H16

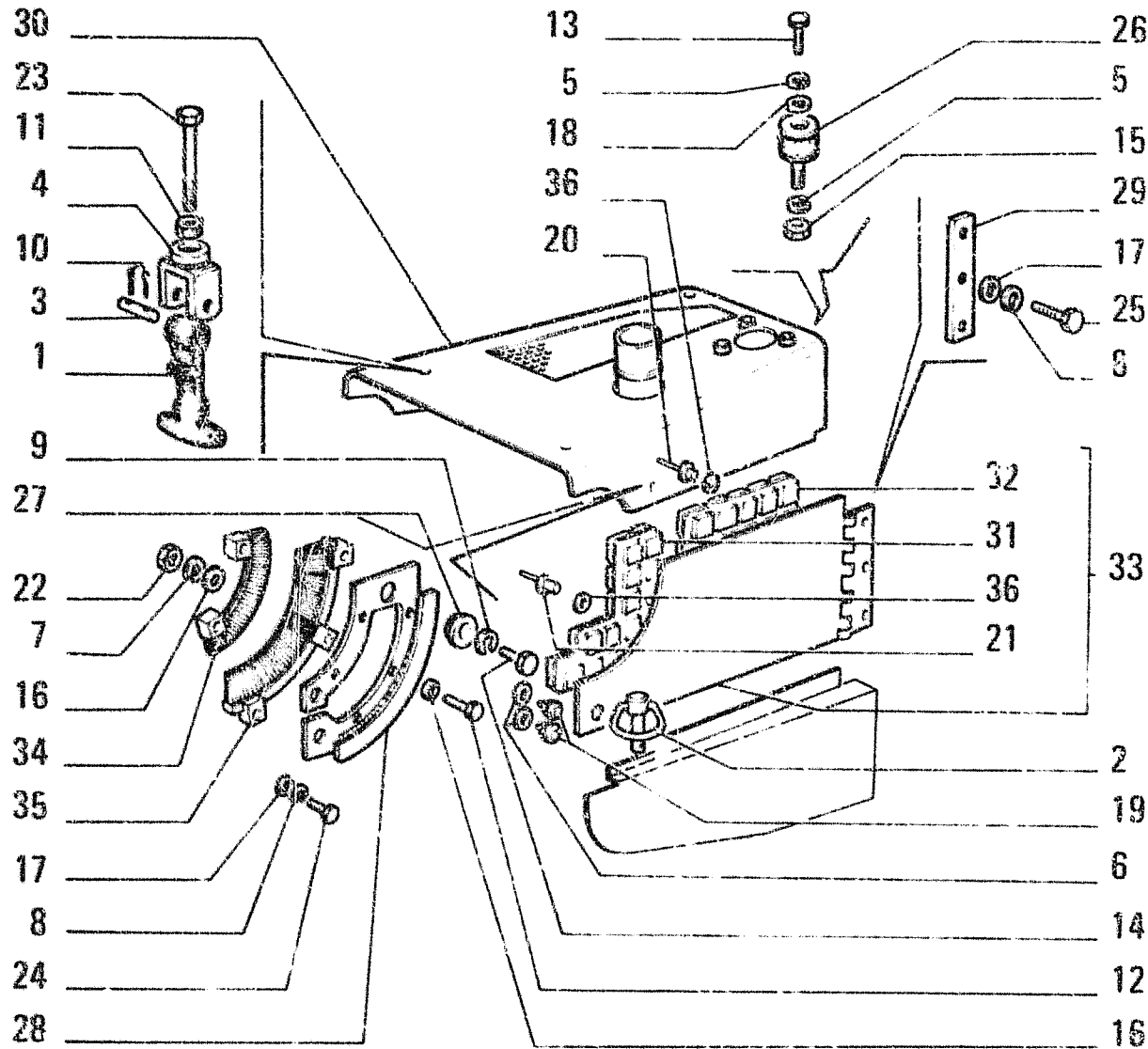

ITEM	PART NUMBER	QTY	TRANS CODE	DESCRIPTION	DESCRIZIONE
1	4952067	2	30G	HOOK C1613	GANCIO C1613
	79014117	2	30G	HOOK D1613	GANCIO D1613
2	4967704	2	81P	SECURING PIN (*) (1")	PERNO DI FISSAGGIO (*) (1")
3	4983695	2	80P	PIN	PERNO
4	4983697	2	85F	YOKE	FORCELLA
5	10516871	4	132R	LOCKWASHER 10x2,5	ROSETTA DI SICUREZZA 10x2,5
6	10519421	4	131R	WASHER (*) (1") 6,15x12	ROSETTA (*) (1") 6,15x12
7	10571571	10	132R	LOCKWASHER (*) (1") 6,1x1,6	ROSETTA DI SICUREZZA (*) (1") 6,1x1,6
8	10571771	10	132R	LOCKWASHER (*) (1") 8,1x2	ROSETTA DI SICUREZZA (*) (1") 8,1x2
9	10571971	2	132R	LOCKWASHER 12,2x2,5	ROSETTA DI SICUREZZA 12,2x2,5
10	10734201	4	276C	COTTER PIN 1,7x18,5	COPIGLIA 1,7x18,5
11	10791021	2	10D	NUT 10x1,25x6	DADO 10x1,25x6
12	10902631	10	40V	SCREW (*) (1") 6x1x25	VITE (*) (1") 6x1x25
13	11106131	2	40V	SCREW 10x1,5x22	VITE 10x1,5x22
14	11112631	2	40V	SCREW 12x1,75x35	VITE 12x1,75x35
15	11701721	2	10F	NUT 10x1,5x8	DADO 10x1,5x8
16	12644421	20	131R	WASHER (*) (1") 6,15x15	ROSETTA (*) (1") 6,15x15
17	12645721	10	131R	WASHER (*) (1") 8,15x20	ROSETTA (*) (1") 8,15x20
18	12646821	2	131R	WASHER 10,2x25	ROSETTA 10,2x25
19	14567080	8	121B	RUBBER STUD (*) (1") 8,5x14	BOITONE DI GOMMA (*) (1") 8,5x14
20	14641995	13	55R	RIVET (*) 2,3x10,4	RIBATTINO (*) 2,3x10,4
21	14642095	14	55R	RIVET (*) 2,3x12	RIBATTINO (*) 2,3x12
22	15896211	10	10D	NUT (*) (1") 6x1x5	DADO (*) (1") 6x1x5
23	15970831	2	40V	SCREW 10x1,25x35	VITE 10x1,25x35

HOOD ASSY - COFANATURA - CAPOTAGE - HAUBE - CAPOT

L1.01 2

N.T.R. 158 - 13.03.1987
604.01.081.03

H17

	DESIGNAZIONE BASE	BASIC DESIGNATION	DESIGNATIONS BASES	GRÜNDBEZEICHNUNGEN	DENOMINACIONES BASE
1076	GRUPPO ACCENSIONE ELETTRONICO	ELECTRONIC IGNITION SYSTEM	GRUPE D'ALLUMAGE	ELEKTRONISCHE	SISTEMA DE ENGEN-
1076		UNIT	ELECTRONIQUE	ZUENDUNGS-AUS-	UNO ELECTRONICO
1076				RUESTUNG	
1076	SEMIPULEGGIA	HALF PULLEY	DEMI-POULIE	SCHIEDSMAELFTE	SEMIPULEA
1076	CILINDRO INCLINAZIONE	TILT CYLINDER	CYLINDRE DE TILT	TILT ZYLINDER	CILINDRO TILT
1071	CILINDRO TILT (HS-L)	TILT CYLINDER (HS-L)	CYLINDRE DE TILT (HS-L)	TILT ZYLINDER (HS-L)	CILINDRO TILT (HS-L)
1072	CILINDRO TILT (HS)	TILT CYLINDER (HS)	CYLINDRE DE TILT (HS)	TILT ZYLINDER (HS)	
1075	COMANDO ATTREZZO POST.	REAR EQUIPMENT CONTROL	COMMANDE D'OUTIL POSTERIEUR	STEUERUNG HECKANLAGEHAFT	MANDO DEL UTIL POSTERIOR
1085	BORDO	EDGE	PROFIL	PROFIL	PERFIL
1085	GRUPPO DI RINVIO	ISLER UNIT	GRUPE DE RENVOI	ZWISCHENGETRIEBE	REENVIO-REDUCTOR
108M	MOLTIPLICATORE	OVERDRIVE	SURMULTIPLIEUR	DREHMOMENTVERSTAEKER	MULTIPLICADOR
108R	RITARDATORE IDRAULICO	HYDRAULIC RETARDER	RETARDATEUR HY-	HYDRAULISCHE VERZO-	RETARDADOR HIDRAU-
108R			DRALIQUE	GERUNGSVORRICHTUNG	LICO
1085	SEMIPISTONO	HALF PISTON	DEMI-PISTON	KOLBENHAELFTE	SEMIEMBOLO
1082	COMANDO E TUBAZIONI	PIPING AND CONTROL	COMMANDE ET TUYANTERIE	STEUERUNG UND LEITUNGEN	
1083	COMANDO II CASSETTO	2ND SPOOL CONTROL	COMMANDE DU 2ME TIROIR	BETAETIGUNG DES 2. STEUERKREISE	
1084	COMANDO III CASSETTO	3RD SPOOL CONTROL	COMMANDE DU 3ME TIROIR	BETAETIGUNG DES 3. STEUERKREISE	MANDO DE LA 3A CARRETES
1087	COMANDO E TUBAZIONI (DAL DEVIATORE)	PIPING AND CONTROL (DIVERT VALVE)	COMMANDE ET TUYANTERIE (DEVIAT)	STEUERUNG LEITUNG (VOM UMSCHALT)	
1098	BORSA PORTACARTE	UTILITY RECESS	VIDE-POCHES	ABLEGEFACH	BOLSA PARA MAPAS
1099	GRUPPO INIEZIONE	INJECTION EQUIPMENT	GRUPE D'INJECTION	EINSPRITZ-AUS-	GRUPO DE INYECCION
1099				RUESTUNG	
1095	MENSOLE INCERNIERAM	TRUNNIONS	CONSOLES	KUGELBOLZEN	REFUERZOS
110A	ATTREZZO ANTERIORE	FRONT IMPLEMENT	EQUIPEMENT AVANT	VORRICHTUNG	IMPLEMENTO ANTERIOR
1100	BRACCI E ARTICOLAZIONI	BOOM/LINKAGE	ARTICULATION DE FLECHE	HUPARM UND UMLENKEBEL	ARTICULACION DEL ANGULO
1101	CILINDRI SOLLEVAMENTO	LIFT CYLINDERS	CYLINDRES LEVAGE	KIPPZYLINDER	CILINDRO ALCE
1102	CILINDRI ROTAZIONE BENNA	DUMP CYLINDERS	CYLINDRES DECHARGE	KIPPZYLINDER	CILINDRO DESCARGA
1103	TUBAZIONI CILINDRI SOLLEV	LIFT CYLINDERS PIPING	CONDUITES CYLINDRES LEVAGE	LEITUNGEN FUER KIPPZYLINDER	TUBERIA CILINDRO ALCE
1104	TUBAZIONI CILINDRI ROTAZIONE	DUMP CYLINDERS PIPING	TUYAUTERIE CYLINDRES BASCULAGE	LEITUNGEN FUER KIPPZYLINDER	
1105	COMANDI ATTREZZO	EQUIPMENT CONTROLS	COMMANDES D'OUTIL		MANDO DEL UTIL
1108	LIMITAZIONE SOLLEV. BRACCI	LIFTING KICK-OUT		HÜHBEGRENZUNG	
110A	AVVOLGIMENTO	WINDING	ENROLLEMENT	WICKLUNG	BOBINA
110F	FUSIBILE	FUSE	FUSIBLE	SICHERUNG	FUSIBLE
1108	GRUPPO OTTICO	LENS/REFLECTOR UNIT	GRUPE OPTIQUE	EINSATZ	GRUPO OPTICO
110P	PIASTRINA	PLAQUE	PLAQUETTE	PLÄTTCHEN	CHAPITA
110T	TESTA A SNODO	ARTICULATED JOINT	JOINT A ROTULE	GELENKKOPF	ARTICULACION
1103	TUBAZIONI CON VALVOLA DEFUSSO	PIPING W/DOWNFLOW VALVE	TUYAUTERIE AVEC SOUPEPE DE DFF		
1107	VALVOLA DISCESA RAPIDA	QUICK RELEASE VALVE	SOUFFRAGE DESCENTE RAPIDE	SCHNELLENKVENTIL	
1109	VALVOLA DI BLOCCO	LOCK VALVE	SOUFFRAGE DE BLOCAGE	RUECKSCHLAGVENTIL	
111C	CAVO	CABLE	CABLE	ELEKTROKABEL	CABLE
111G	GRUPPO DI REGOLAZIONE	GOVERNOR ASSEMBLY	GRUPE REGULATEUR	REGLERGRUPPE	REGULADOR

	DESIGNAZIONE BASE	BASIC DESIGNATION	DESIGNATIONS-BASES	GRUNDBEZEICHNUNGEN	DENOMINACIONES BASE
1010	GRIGLIA	GRID	GRILLE	SCHUTZGITTER	REJILLA
1011	FORCELLE	STRUTS	FOURCHES	STREBEN	
1012	FORCELLE RINFORZATE	STRUTS H.D	FOURCHES RENFORCEES	STREBEN VERSTAERKTE AUSFUEHRUNG	
102B	BOMBOLETTA	BOTTLE	BOUTEILLE	FLASCHE	ENVASE DE GAS
102E	ELEVATORE	ELEVATOR	ELEVATEUR	FOERDERER	ELEVADOR
102G	GRU	CRANE	GRUE	KRAN	GRUA
102P	PIANALE	PLATFORM	PLATEAU	PLATTE	PLATAFORMA
1022	LASERPLANE-TRASMETTITORE		LASERPLANE TRANSMETTEUR	LASERPLANE-SENDER	
1023	LASERPLANE-RICEVITORE		LASERPLANE RECEPTEUR	LASERPLANE-EMPPFAENGER	
103A	ASTUCCIO PORTARULLI	ROLLER CASING	ETUI PORTE-GALET	HUELSE	CARTER PORTARRO- DILLOS
103A					
103E	ESPULSORE	EJECTOR			
103M	MOLLA A DIAFRAMMA	DISC SPRING	RONDELLE-RESSORT	FEDERSCHEIBE	DIAPHRAGMA DE MUE- LLE
103M					
103P	PIANTONE	STEERING COLUMN	COLONNE DIRECTION	LENKSAEULE	COLUMNA DIRECCION
103S	SEMIDISCINETTO	HALF BEARING	DEMI-ROULEMENT	LAGERHALBSHALEN	SEMIRODAMIENTO
1039	CILINDRI ANGOLAZIONE	ANGLE CYLINDERS	CYLINDRES AD	SCHWENKZYLINDER	
104A	ATTACCO PER ATTREZZI	EQUIPMENT MOUNTING	ATTELAGE DES OU- TILS	GERAETEKUPPLUNG	ENGANCHE DE LOS UTILES
104A					
104S	GRUPPO COMANDO DI DISTRIBUZIONE	CAMSHAFT DRIVE SET	JEU DE COMMANDE DE DISTRIBUTION	STEUERUNGSANTRIEB- SATZ	JUEGO DE PINONES DE LA DISTRIBUCION
104S	SEMIDISCO	HALF DISC	DEMI-DISQUE	HALBSCHEIBE	SEMIDISCO
1040	BRACCI E TIRANTI (HSU-HS)	PUSHBEAMS AND STRUTS (HSU-HS)	BRAS ET TIRANTS (HSU-HS)	SCHUBARME UND STREBEN(HSU-HS)	BRAZOS Y TIRANTES (HSU-HS)
1041	BRACCI E TIRANTI (HS-L)	PUSHBEAMS AND STRUTS (HS-L)	BRAS ET TIRANTS (HS-L)	SCHUBARME UND STREBEN(HS-L)	BRAZOS Y TIRANTES (HS-L)
1042	BRACCI E TIRANTI (HS)	PUSHBEAMS AND STRUTS (HS)	BRAS ET TIRANTS (HS)	SCHUBARME UND STREBEN(HS)	BRAZOS Y TIRANTES (HS)
1043	BRACCI E TIRANTI (TILT-PITCH)	PUSHBEAMS & STRUTS(TILT-PITCH)	BRAS ET TIRANTS (TILT-PITCH)	SCHUBARME STREBEN(TILT-PITCH)	BRAZOS Y TIRANTES (TILT-PITCH)
105A	AVVISATORE ACUSTICO	HORN	AVERTISSEUR	HUPE	BOCINA
105F	FUNE	CABLE	CABLE	DRABTSEIL	CABLE
105G	GRUPPO DI ROTAZIONE	ROTATION UNIT	GROUPE DE ROTATION	DREHAGGREGAT	GRUPO DE ROTACION
105M	MOLLETTA	SPRING FASTENER	AGRAFE	KLEMMSTUECK	SUJETADOR
105P	PIASTRA	PLATE	PLAQUE	PLATTE	PLACA
105R	RISCALDATORE	HEATER	RECHAUFFEUR	HEIZUNG	CALENTADOR
105S	SEMIGIUNTO	HALF COUPLING	DEMI-JOINT	HALBGELENK	SEMIACOPLAMIENTO
106B	BORDINO	MOLDING	PROFILE	PROFIL	PERFIL
106G	GRUPPO AMMORTIZZANTE	SHOCK ABSORBING UNIT	GROUPE AMORTISSEUR	STOSSDAEMPFER	GRUPO AMORTIGUADOR
106R	RISCALDATORE ELETTRICO	HEATING ELEMENT	RECHAUFFEUR ELEC- TRIQUE	ELEKTRISCHE HEIZGERAET	RESISTENCIA DE CALDEO
106R					
106S	SEMIGUARNIZIONE	HALF GASKET	DEMI-JOINT	DICHTUNGSHAELFTE	SEMIGUARNICION
1065	CILINDRO TILT (ALL-HYDRAULIC)	TILT CYLINDER (ALL-HYDRAULIC)	CYLINDRE DE TILT(ALL-HYDRAULIC)	TILT ZYLINDER (ALL-HYDRAULIC)	
107B	BORDO DI GOMMA	WEATHERSTRIP	CAOUTCHOUC	PROFILGUMMI	GOMA

DESIGNAZIONE BASE	BASIC DESIGNATION	DESIGNATIONS-BASES	GRUNDZEICHNUNGEN	DENOMINACIONES BASE
EL	ELIMINATO	DELETED	ELIMINE	ELIMINADO
ERR	ERRATA	WRONG	ERRATA	DONDE DICE
EST	ESTERNO	OUTER	EXTERIOR	EXTERIOR
FA00	AGRICOLO A CINGOLI	AGRICULTURAL CRAWLER	TRACT AGRICOLE SUR CHENILLES	TRACTOR AGRICOLA SOBRE ORUGAS
FB00	TERNA	BACKHOE LOADER	CHARGEUSE-PELLETEUSE	TERNA SOBRE RUEDAS
FD0P	APRIPISTA CINGOLI LGP	CRAWLER DOZER-LGP	BOUTEUR SUR CHENILLES LGP	ABRETROCHAS LGP
FD00	APRIPISTA CINGOLI	CRAWLER DOZER	BOUTEUR SUR CHENILLES	ABRETROCHAS
FE0P	ESCAVATORE A CINGOLI LC	CRAWLER EXCAVATOR-LC	PELLE SUR CHENILLES LC	EXCAVADORA SOBRE ORUGAS LC
FE0R	ESCAVATORE A CINGOLI HD	CRAWLER EXCAVATOR-HD	PELLE SUR CHENILLES HD	EXCAVADORA SOBRE ORUGAS HD
FE0W	ESCAVATORE A RUOTE	WHEEL EXCAVATOR	PELLE SUR PNEUS	EXCAVADORA SOBRE RUEDAS
FE00	ESCAVATORE A CINGOLI	CRAWLER EXCAVATOR	PELLE SUR CHENILLES	EXCAVADORA SOBRE ORUGAS
FG00	MOTOLIVELLATRICE	MOTOR-GRADER	NIVELEUSE SUR PNEUS	MC (ONIVELADORA
FL0P	CARICATORE A CINGOLI LGP	CRAWLER LOADER-LGP	CHARGEUSE SUR CHENILLES LGP	CARGADORA SOBRE ORUGAS LGP
FL00	CARICATORE A CINGOLI	CRAWLER LOADER	CHARGEUSE SUR CHENILLES	CARGADORA SOBRE ORUGAS
FP00	POSATUBI	PIPE-LAYER	POSEUR DE TUBES	TIENDETUBOS
FR0C	COMPATTATORE A RUOTE	WHEEL COMPACTOR		
FR00	CARICATORE ART RUOTE	WHEEL LOADER	CHARGEUSE SUR PNEUS	CARGADORA SOBRE RUEDAS
FS00	MOTORUSPA	MOTOR-SCRAPER	DECAPEUSE SUR PNEUS	MOTOTRAILLA
G214	TRASLAZIONE RETROESCAVATORE	BACKHOE TRASLATION		
INF	INFERIORE	LOWER	INFERIEUR	INFERIOR
INT	INTERNO	INNER	INTERIEUR	INTERIOR
LAT	LATERALE	SIDE	LATERAL	LATERAL
POST	POSTERIORE	REAR	ARRIERE	POSTERIOR
SALD	DA SALDARE	TO BE WELDED	A SOLDER	SOLDAR
SEM	SEMILAVORATO	SEMIFINISHED	MI-OUYRE	SEMIELABORADO
SN	SINISTRO	LEFT	GAUCHE	IZQUIERDO
SP	SPESSORE	THICKNESS	EPAISSEUR	GRUESO
SUP	SUPERIORE	UPPER	SUPERIOR	SUPERIOR
VED	VEDERE SGR	SEE SGR	VOIR SGR	VEASE SGR
1003	ARRESTO MOTORE	ENGINE STOP	ARRET DU MOTEUR	PARO DEL MOTOR
1000	BOCCOLA DI GOMMA	RUBBER BUSH	BAGUE CAOUTCHOUC	COJINETE DE CAUCHO
100C	CAVALLOTTO	RETAINER	ARRETOIR	SUJETADOR
100G	GRIGLIA DEL RADIATORE	RADIATOR GRILLE	GRILLE DE RADIA- TEUR	CORAZA DEL RADIA- DOR
100M	MOLLA	SPRING	RESSORT	MUELLE
100R	RIPOSTIGLIO CRUSCOTTO	RECESS	BOITE A GANTS	GUANTERA
100S	SEMICONO	LOCK CONE	DEMI-CONE	CHAVETA CONICA
1003	ARCONI (ALL-HYDRAULIC)	C-FRAME (ALL-HYDRAULIC)	ETRIER (ALL-HYDRAULIC)	ARCON (ALL-HYDRAULIC)
101A	ASTUCCIO	CASING	ETUI	ESTUCHE
101E	ELETTROLITO	ELECTROLYTE	ELECTROLYTE	ELECTROLYTE

L

BODY • CARROZZERIA • CARROSSERIE • AUFBAU • CARROCERIA

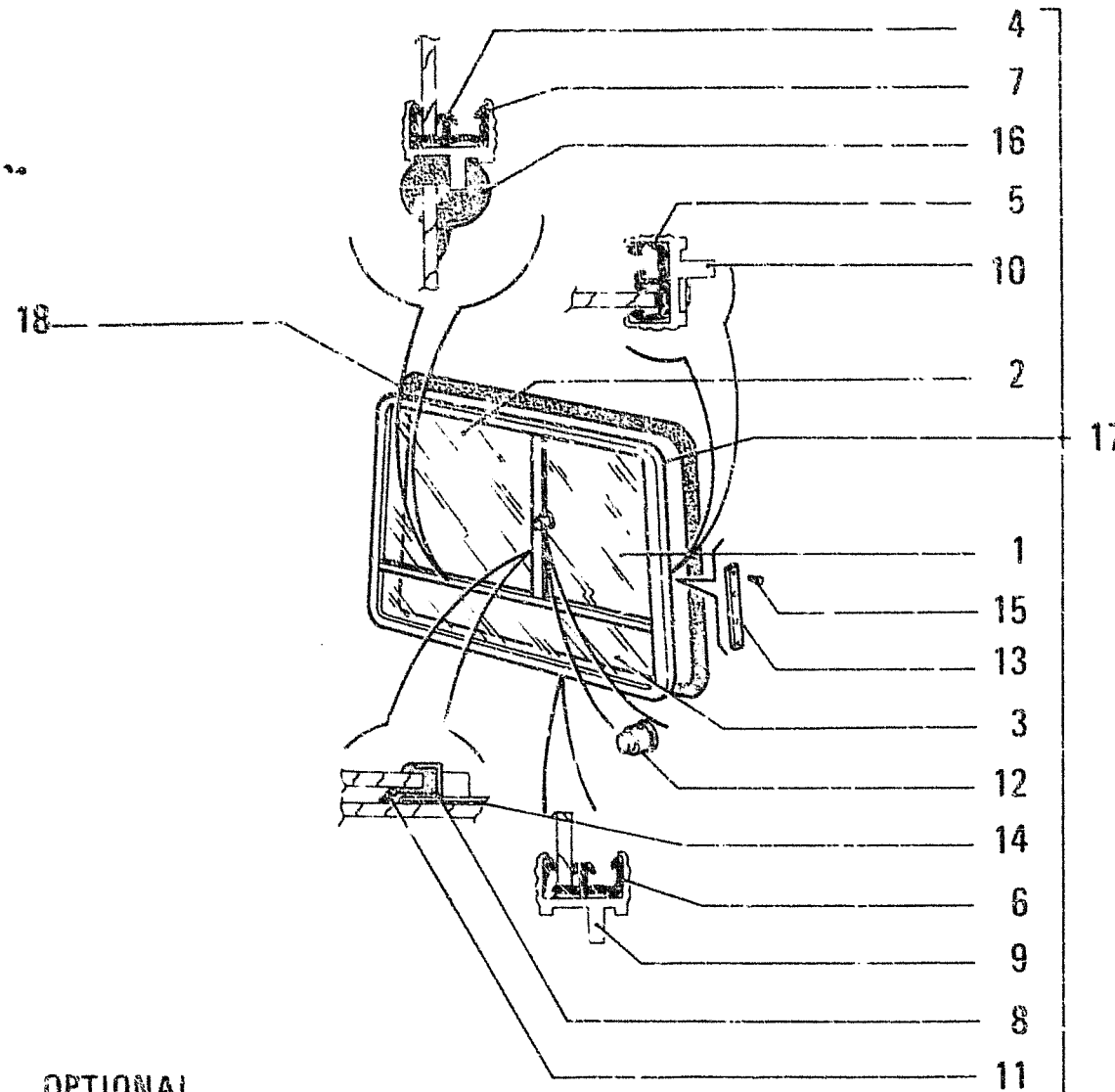

OPTIONAL
VARIANTE 30.C570.18.1

ITEM	PART NUMBER	QTY	TRANS CODE	DESCRIPTION	DESCRIZIONE
1	79051801	1	315C	GLASS PANE	CRISTALLO
2	79051802	1	315C	GLASS PANE - UPPER	CRISTALLO - SUPERIORE
3	79051803	1	315C	GLASS PANE - LOWER	CRISTALLO - INFERIORE
4	79051800	1	122G	SEAL	GUARNIZIONE
5	79051798	1	122G	SEAL	GUARNIZIONE
6	79051799	1	122G	SEAL	GUARNIZIONE
7	79051797	1	180T	CROSS BLAM	TRAVEVERSA
8	76016148	1	115M	PILLAR C3265	MONTANTE C3265
	79051846	1	115M	PILLAR C3265	MONTANTE C3265
9	79051795	1	295C	BEZEL	CORNICE
10	79051796	1	295C	BEZEL	CORNICE
11	76016149	1	120G	GASKET C3265	GUARNIZIONE PIANA C3265
	79051804	1	120G	GASKET C3265	GUARNIZIONE PIANA C3265
12	79046604	1	20M	HANDLE	MANIGLIA
13	79040912	2	105P	PLATE	PIASTRA
14	79051055	1	75D	SPACER	DISTANZIALE
15	14642591	12	55R	RIVET 2,7x9	RIBATTINO 2,7x9
16	79051843	1	122G	SEAL	GUARNIZIONE
17	79051794	1	69F	WINDOW - REAR ASSEMBLY	FINESTRA - POSTERIORE COMPLETO
18	79051807	1	122G	SEAL	GUARNIZIONE

79043237

CAB - CABINA - CABINE - FAHREKHAUS - CABINA

I-2

L1.04

7

N.T.R. 200 - 15.10.1990

604.01.081.05

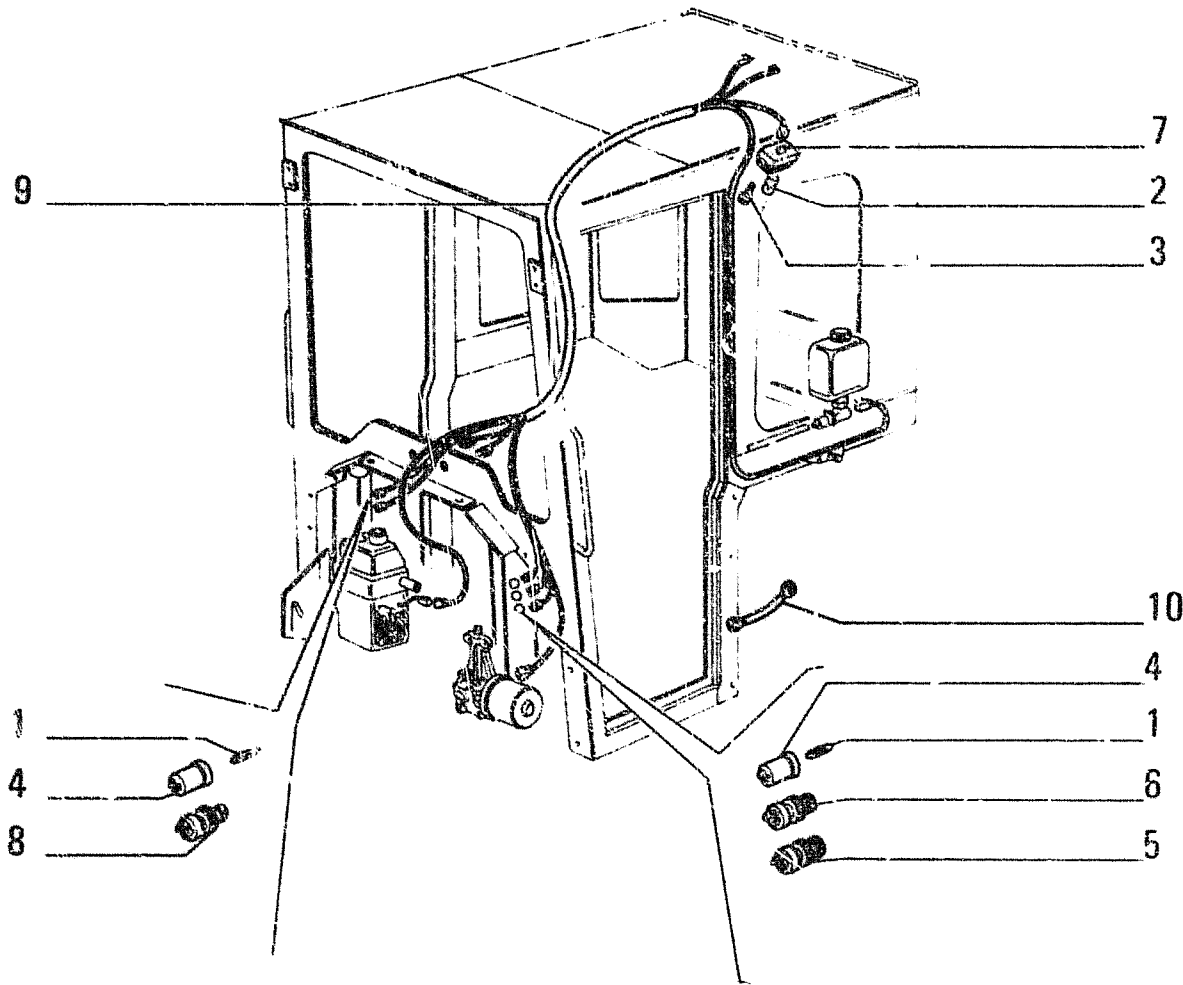

ITEM	PART NUMBER	QTY	TRANS CODE	DESCRIPTION	DESCRIZIONE
1	10858090	2	110F	FUSE 5,7x24,9	FUSIBILE 5,7x24,9
2	10863190	1	30L	LAMP 11x35	LAMPADA 11x35
3	17669001	2	4JV	SCREW 6x9,5	VITE 6x9,5
4	79011645	3	185F	FUSE HOLDER	PORTAFUSIBILE
5	79032226	1	75I	SWITCH	INTERRUTTORE
6	79032225	1	236P	PUSH BUTTON	PULSANTE
7	79020934	1	135P	CEILING LAMP	PLAFONIERA
8	79032224	1	75I	SWITCH	INTERRUTTORE
9	79052468	1	111C	CABLE - ASSEMBLY	CAVO - COMPLETO
10	79050329	1	111C	CABLE	CAVO

OPTIONAL
VARIANTE 30.0570 18.1

79043237
CAB - CABINA - CABINE - FAHRERHAUS - CABINA.

1	L1.04	6
N.T.R. 114 - 16-01-1984 604.01.081.01		

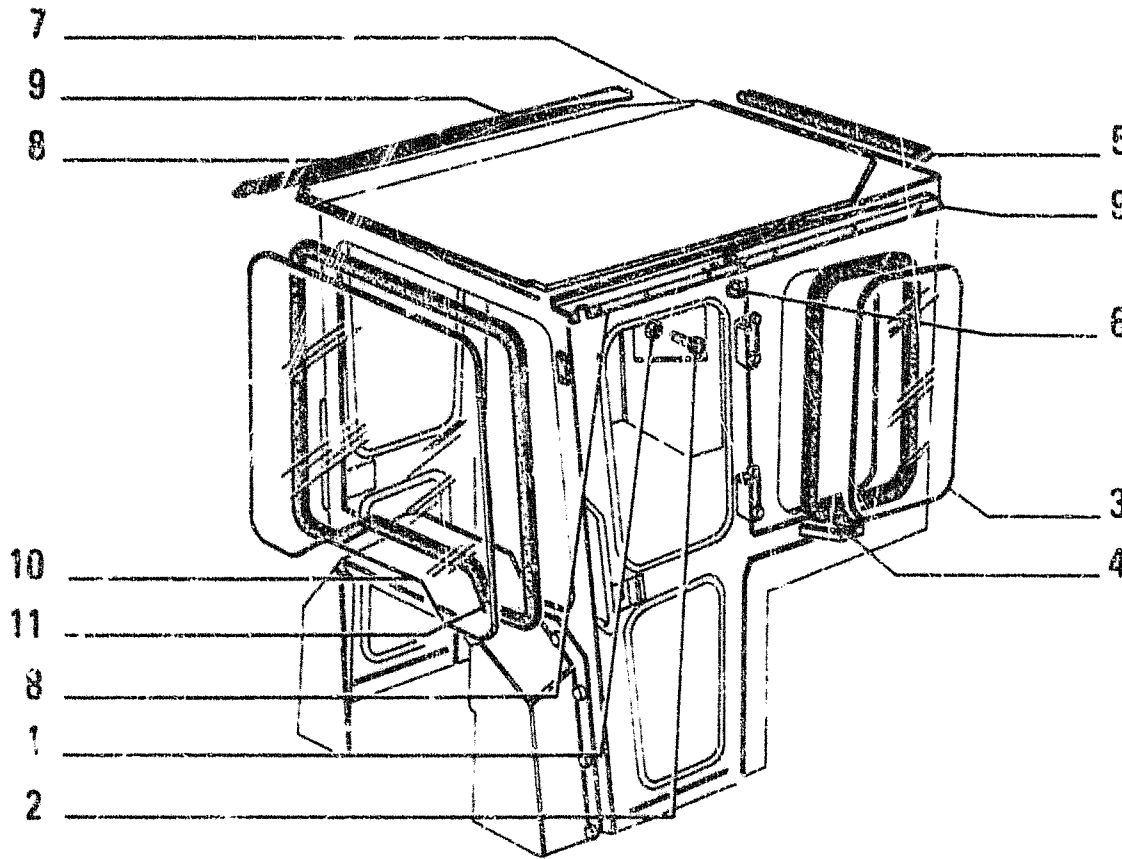

ITEM	PART NUMBER	QTY	TRANS CODE	DESCRIPTION	DESCRIZIONE
1	10571470	14	132R	LOCKWASHER 5,1x1,2	ROSETTA DI SICUREZZA 5,1x1,2
2	15900810	14	40V	SCREW 10x13	VITE 10x13
3	79051805	2	315C	GLASS PANE	CRISTALLO
4	79051806	2	120G	GASKET	GUARNIZIONE PIANA
5	79051835	1	216P	RUBBER SECTION	PROFILATO DI GOMMA
6	79051844	6	120B	BUTTON	BOTTONE
7	79051834	1	116R	COVERING	RIVESTIMENTO
8	79051832	2	108B	EDGE	BORDO
9	79051833	2	108B	EDGE	BORDO
10	79044383	1	315C	GLASS PANE - FRONT	CRISTALLO - ANTERIORE
11	79044384	1	120G	GASKET	GUARNIZIONE PIANA

OPTIONAL VARIANTE 30.0570.18.1

79043237
 CAB - CABINA - CABINE - FAHRERHAUS - CABINA

L1.04 5
 N.T.R. 158 - 13.03.1987
 604.01.081.03

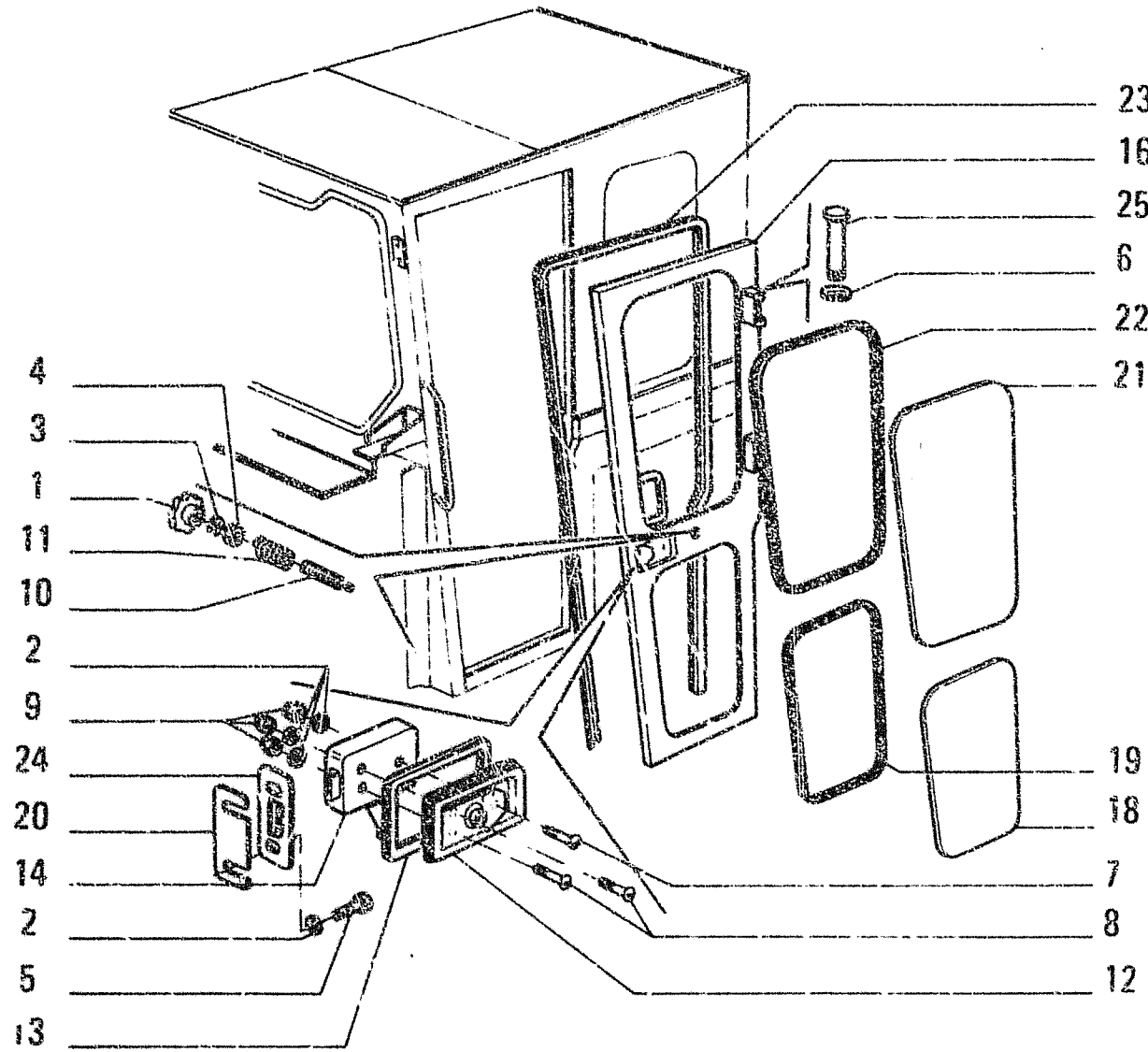

OPTIONAL
VARIANTE 30.0570.18.1

ITEM	PART NUMBER	QTY	TRANS CODE	DESCRIPTION	DESCRIZIONE
1	4952020	2	150P	KNOB	POMELLO
2	10571571	10	132R	LOCKWASHER 6,1x1,6	ROSETTA DI SICUREZZA 6,1x1,6
3	10571870	2	132R	LOCKWASHER 10,2x2,2	ROSETTA DI SICUREZZA 10,2x2,2
4	10788721	2	10D	NUT 10x1,5x6	DADO 10x1,5x6
5	10902021	4	40V	SCREW 6x1x12	VITE 6x1x12
6	11087876	4	45A	RING 6x12	ANELLO 6x12
7	12214111	2	40V	SCREW	VITE
8	13277411	4	40V	SCREW 6x1x60	VITE 6x1x60
9	14054511	6	10D	NUT 6x1x12	DADO 6x1x12
10	79017741	2	80P	PIN	PERNO
11	79017742	2	100M	SPRING	MOZZA
12	79031813	1	20M	HANDLE - RIGHT	MANIGLIA - DESTRO
	79051870	1	20M	HANDLE - LEFT	MANIGLIA - SINISTRO
13	79031814	2	120G	GASKET	GUARNIZIONE PIANA
14	79031815	1	120S	LOCK	SERRATURA
15	79031816	1	120S	LOCK	SERRATURA
16	79051730	1	180P	DOOR - LEFT ASSEMBLY	PORTA - SINISTRO COMPLETO
	79051731	1	180P	DOOR - RIGHT ASSEMBLY	PORTA - DESTRO COMPLETO
18	79043296	2	315C	GLASS PANE	CRISTALLO
19	79043300	2	120G	GASKET	GUARNIZIONE PIANA
20	79043302		198S	SHIM	SPESSORE
21	79043304	2	315C	GLASS PANE	CRISTALLO
22	79043307	2	120G	GASKET	GUARNIZIONE PIANA
23	79043316	2	216P	RUBBER SECTION	PROFILATO DI GOMMA
24	79043380	2	80A	STOP	ARRESTO
25	79044358	4	80P	PIN	PERNO

79043237

CAB - CABINA - CABINE - FAHRERHAUS - CABINA

L1.04

4

N.T.R. 114 - 16-01-1984

604.01.051.01

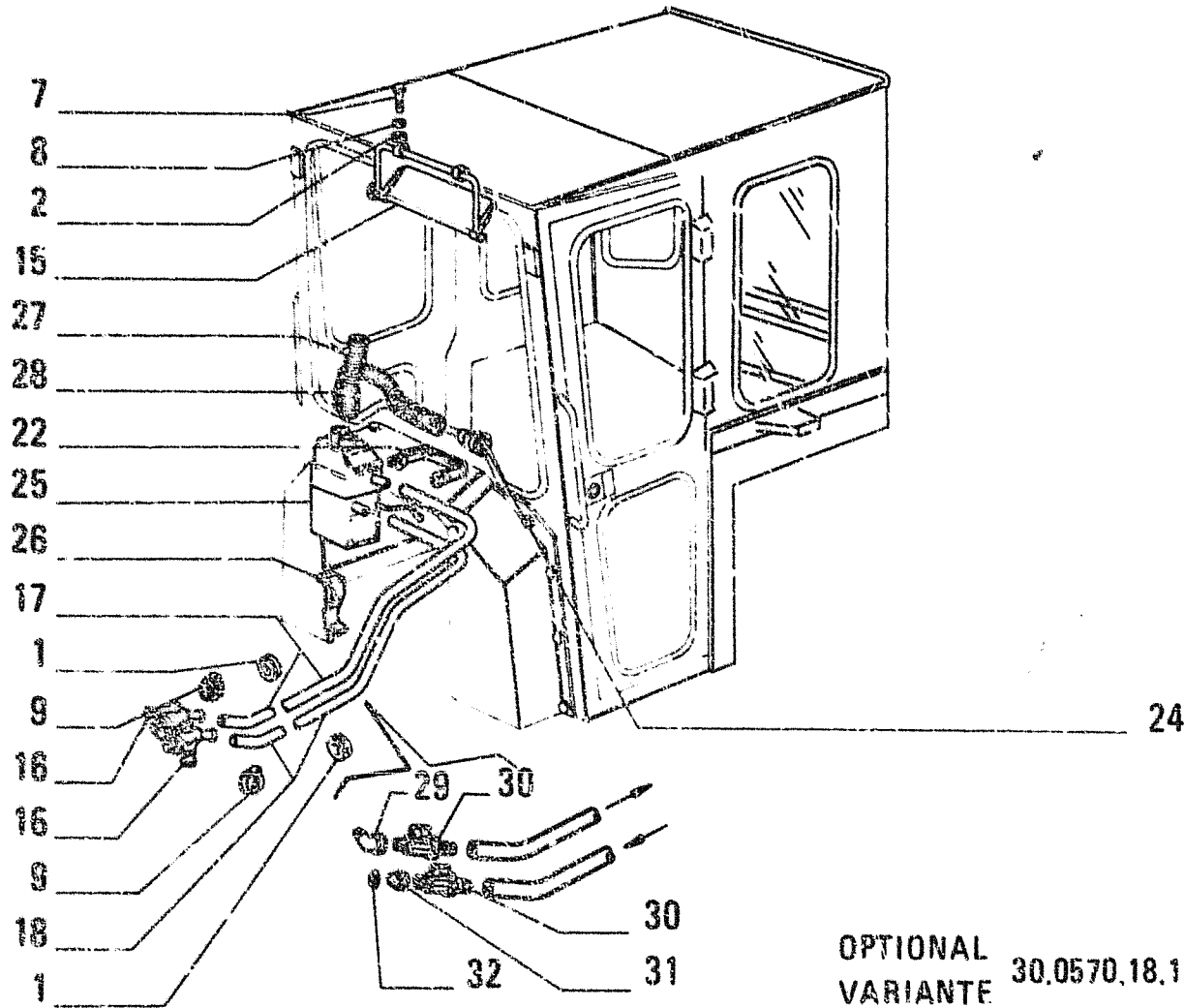

ITEM	PART NUMBER	QTY	TRANS CODE	DESCRIPTION	DESCRIZIONE
	32 10278660				02956

79043237
 CAB - CABINA - CABINE - FAHRERHAUS - CABINA

L1.04

3

N.T.R. 191 - 20.02.1990
 604.01.081.04

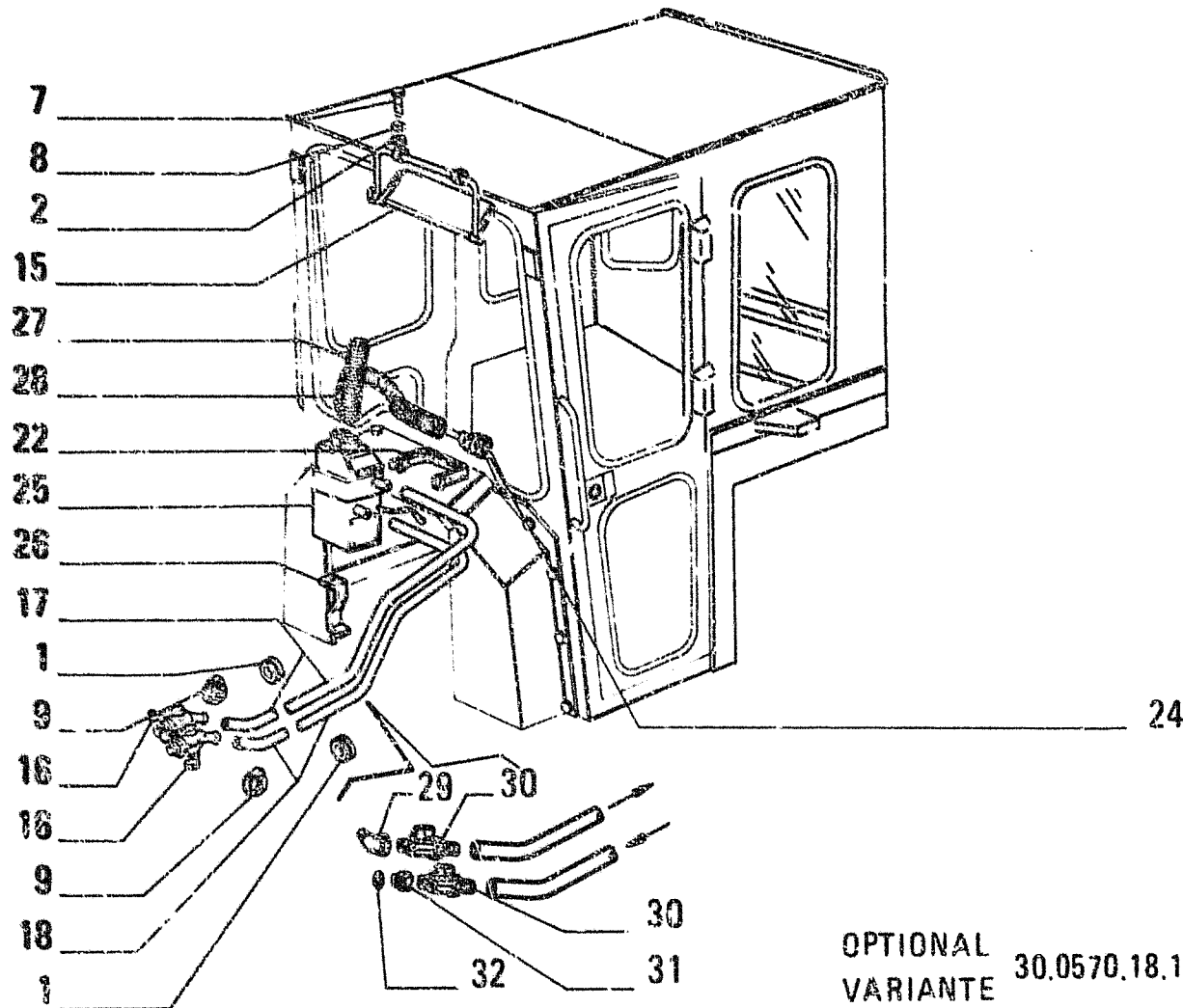

ITEM	PART NUMBER	QTY	TRANS CODE	DESCRIPTION	DESCRIZIONE
1	10097680	2	45A	RING 18x33	ANELLO 18x33
2	10519301	4	131R	WASHER 5,15x10	ROSETTA 5,15x10
7	10977821	4	40V	SCREW 5x0,8x16	VITE 5x0,8x16
8	111105471	4	132R	LOCKWASHER 5,1x1,1	ROSETTA DI SICUREZZA 5,1x1,1
9	12173590	4	31F	CLAMP 14/24x8 C2956	FASCETTA 14/24x8 C2956
	79083842	4	31F	CLAMP D2956	FASCETTA D2956
15	79027938	1	27P	LIGHT SCREEN - ASSEMBLY	PARALUCE - COMPLETO
16	79041301	2	150R	COCK C2956	RUBINETTO C2956
17	76015039	L	285T	HOSE 2,000M D2956	TUBO FLESSIBILE 2,000M D2956
	79053326	1	192T	HOSE ASSY C2956	TUBO FLESS.C/RACCORDI C2956
18	76015039	L	285T	HOSE 2,300M D2956	TUBO FLESSIBILE 2,300M D2956
	79053327	1	192T	HOSE ASSY C2956	TUBO FLESS.C/RACCORDI C2956
22	79043345	1	172C	SECURING STRAP	CINGHIA DI FISSAGGIO
24	79044382	1	95B	BUSHING	BOCCOLA
25	79043354	1	105R	HEATER - ASSEMBLY SEE E1.02	RISCALDATORE - COMPLETO VEDERE E1.02
26	79053325	1	225S	BRACKET	STAFFA
27	79044554	1	193T	TUBE	TUBO RIGIDO
28	79044555	1	193T	TUBE	TUBO RIGIDO
29	76014976	1	20R	FITTING D2956	RACCORDO D2956
30	76014887	2	150R	COCK D2956	RUBINETTO D2956
31	76014857	1	20R	FITTING D2956	RACCORDO D2956
32	10278660	1	122G	SEAL 16,2x22 D2956	GUARNIZIONE 16,2x22

79043237
 CAB - CABINA - CABINE - FAHRERHAUS - CABINA

L1.04 3

N.T.R. 191 - 20.02.1990
 604.01.081.04

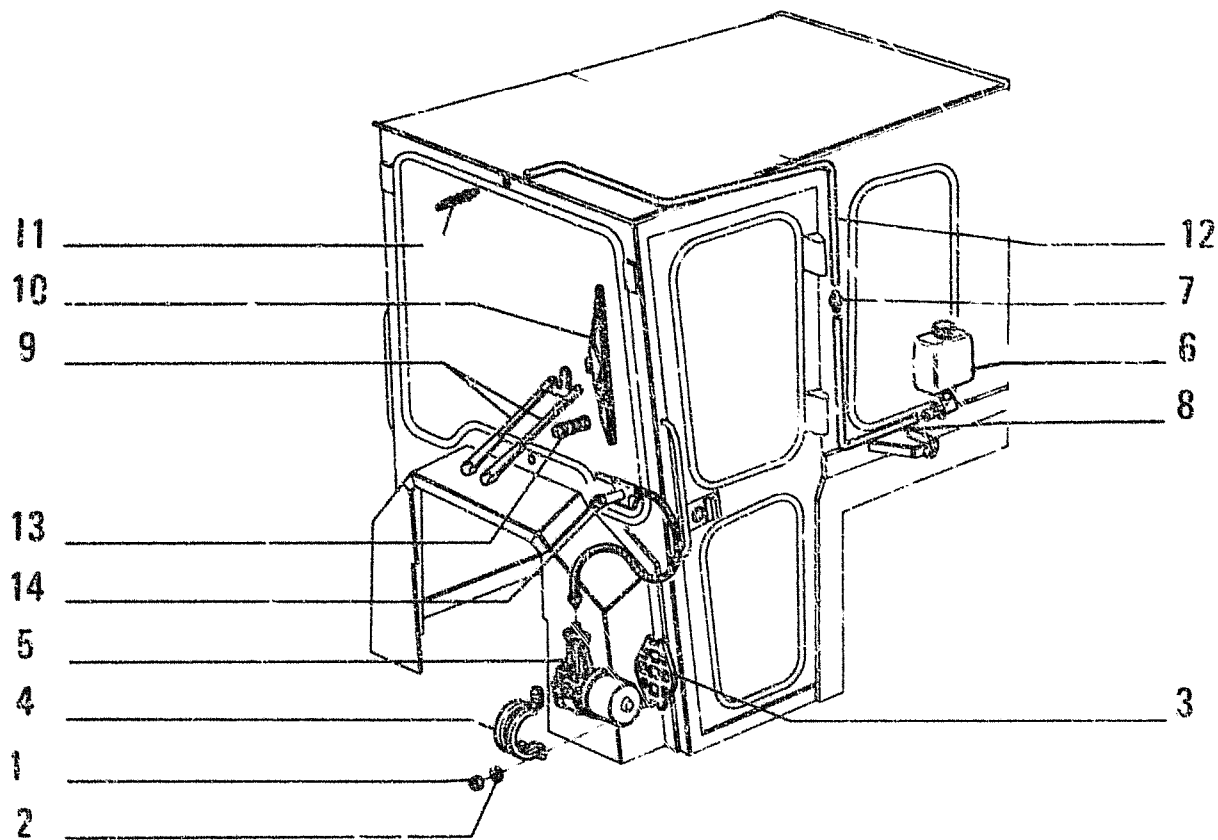

ITEM	PART NUMBER	QTY	TRANS CODE	DESCRIPTION	DESCRIZIONE
1	12574211	2	10D	NUT 6x1x7,8	DADO 6x1x7,8
2	12643701	2	131R	WASHER 6,15x18	ROSETTA 6,15x18
3	79017755	1	60T	BLOCK	TASSELLO
4	79017756	1	31F	CLAMP	FASCETTA
5	79020832	1	134M	MOTOR	MOTORINO
6	79020842	1	19V	PAN	VASCHETTA
7	79020844	1	10V	VALVE	VALVOLA
8	79020952	1	193T	TUBE	TUBO RIGIDO
9	79026217	1	130B	ARM	BRACCIO
10	79031831	1	177S	BRUSH	SPAZZOLA
11	79043299	1	38L	WINDSHIELD WASHER	LAVACRISTALLI
12	79043312	1	193T	TURE	TUBO RIGIDO
13	79044386	1	80P	PIN	PERNO
14	79044387	1	64R	MITER GEARING - ASSEMBLY	RINVIO ANGOLARE - COMPLETO

OPTIONAL VARIANTE 30.0570.18.1

79043237
 CAB - CABINA - CABINE - FAHRERHAUS - CABINA

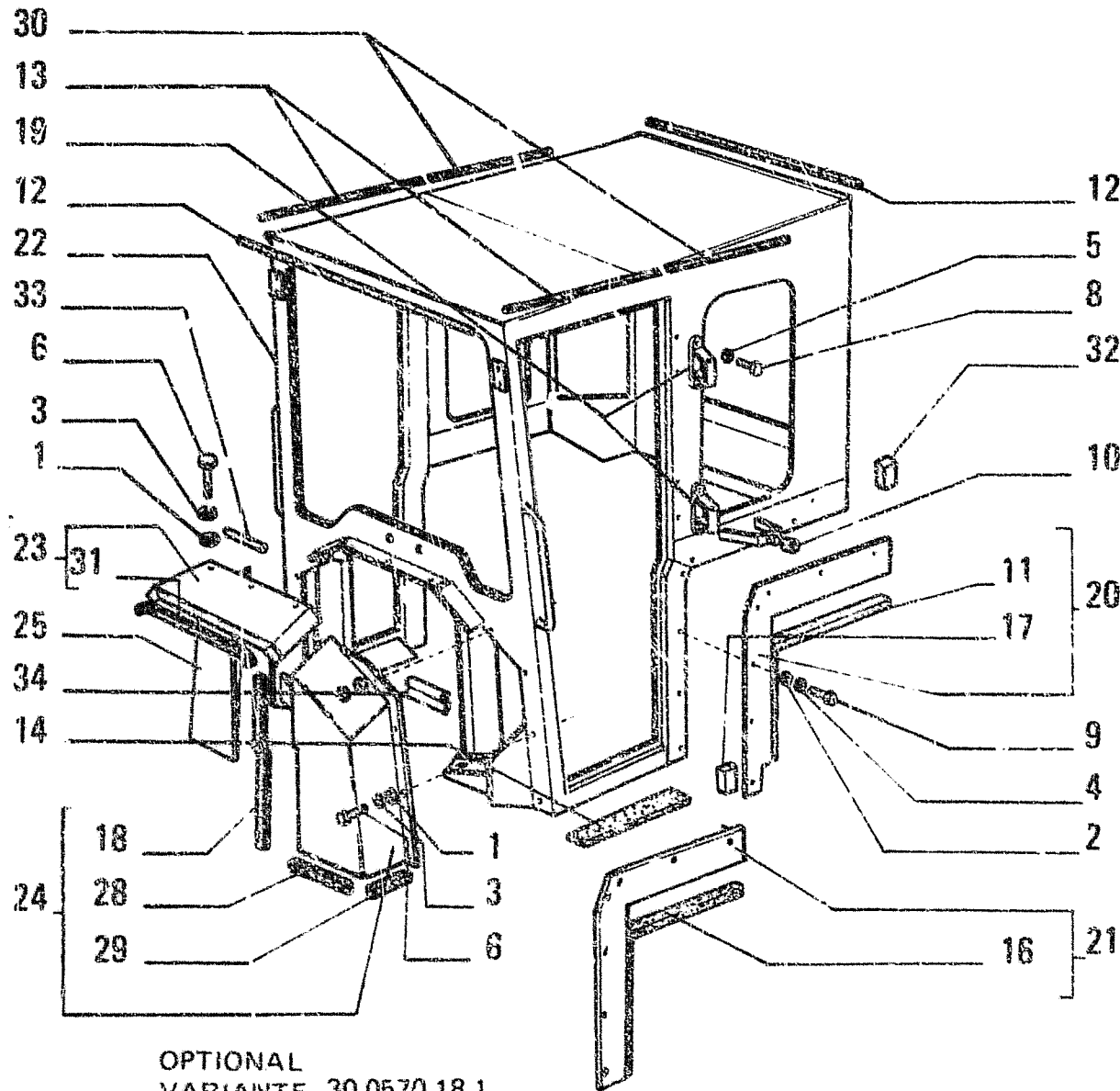

ITEM	PART NUMBER	QTY	TRANS CODE	DESCRIPTION	DESCRIZIONE
25	79052461	1	70R	GUARD - FRONT SIDE RIGHT ASSEMBLY	RIPARO - ANTERIORE LATERALE DESTRO COMPLETO
28	79053330	2	120G	GASKET	GUARNIZIONE PIANA
29	79052459	2	120G	GASKET	GUARNIZIONE PIANA
30	79051842	2	215P	CHANNEL	PROFILATO
31	79053328	1	120G	GASKET	GUARNIZIONE PIANA
32	79052166	1	120G	GASKET	GUARNIZIONE PIANA
33	79045083	1	215P	CHANNEL	PROFILATO
34	79052460	2	120G	GASKET	GUARNIZIONE PIANA

OPTIONAL
VARIANTE 30.0570.18.1

79043237
CAB - CABINA - CABINE - FAHRERHAUS - CABINA

1 L1.04 1

N.T.R. 114 - 16-01-1984
604.01.081.01

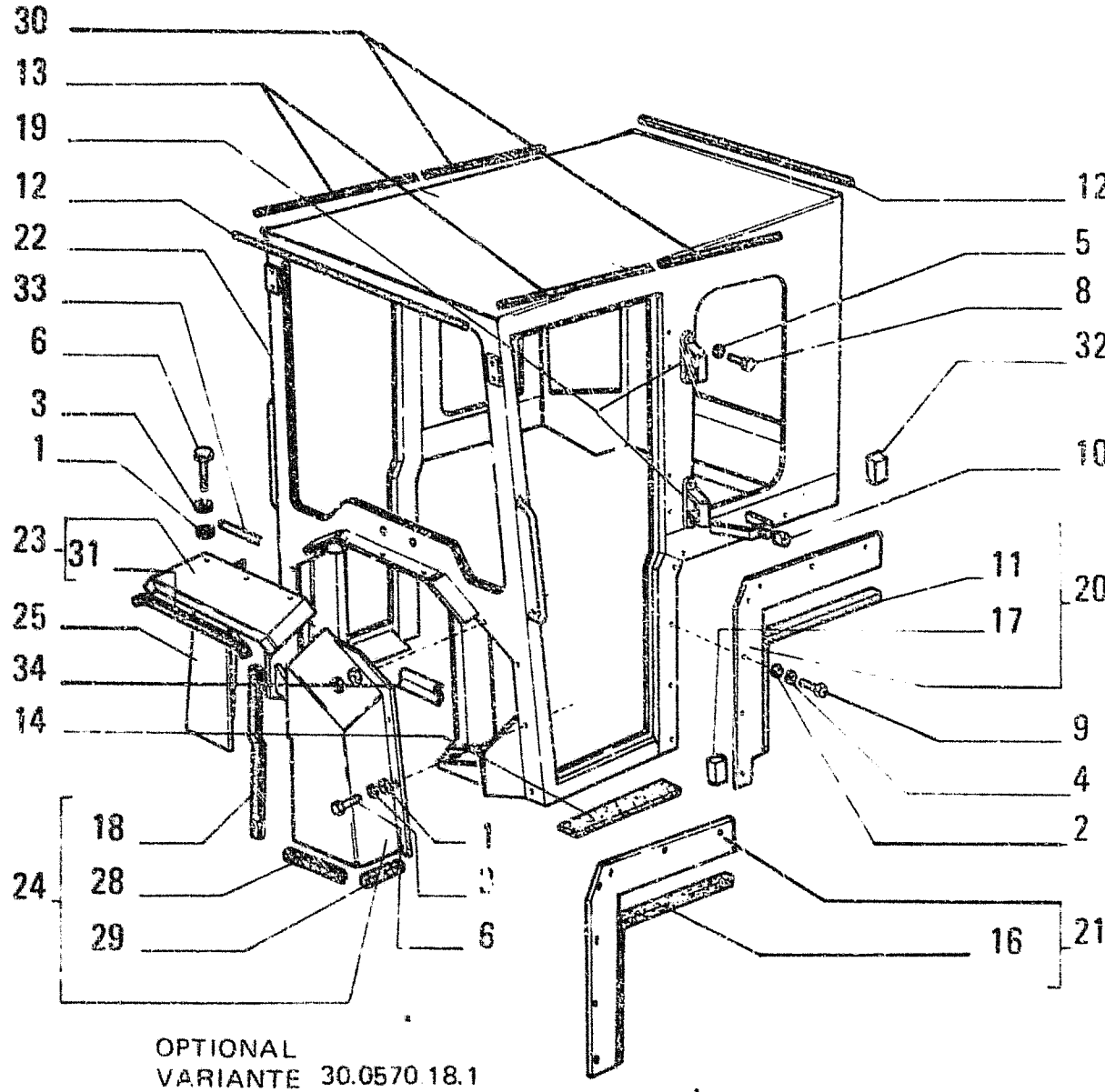

ITEM	PART NUMBER	QTY	TRANS CODE	DESCRIPTION	DESCRIZIONE
1	1051940	15	131R	WASHER 6,15x12	ROSETTA 6,15x12
2	1051960	16	131R	WASHER 8,15x17	ROSETTA 8,15x17
3	10571570	15	132R	LOCKWASHER 6,1x1,6	ROSETTA DI SICUREZZA 6,1x1,6
4	10571770	16	132R	LOCKWASHER 8,1x2	ROSETTA DI SICUREZZA 8,1x2
5	10571870	8	132R	LOCKWASHER 10,2x2,2	ROSETTA DI SICUREZZA 10,2x2,2
6	10902421	15	40V	SCREW 6x1x20	VITE 6x1x20
8	15970721	8	40V	SCREW 10x1,25x25	VITE 10x1,25x25
9	16043021	16	40V	SCREW 8x1,25x12	VITE 8x1,25x12
10	79021573	2	60T	BLOCK	TASSELLO
11	79051814	1	120G	GASKET	GUARNIZIONE PIANA
12	79051840	2	215P	CHANNEL	PROFILATO
13	79051841	2	215P	CHANNEL	PROFILATO
14	79051837	1	120G	GASKET - LEFT	GUARNIZIONE PIANA - SINISTRO
15	79051838	1	120G	GASKET - RIGHT	GUARNIZIONE PIANA - DESTRO
16	79051819	1	120G	GASKET	GUARNIZIONE PIANA
17	79050293	2	120G	GASKET	GUARNIZIONE PIANA
18	79053329	2	120G	GASKET - SIDE FRONT	GUARNIZIONE PIANA - LATERALE ANTERIORE
19	79043350	4	140C	HINGE - ASSEMBLY	CERNIERA - COMPLETO
20	79051813	1	70R	GUARD - SIDE LEFT ASSEMBLY	RIPARO - LATERALE SINISTRO COMPLETO
21	79051818	1	70R	GUARD - SIDE RIGHT ASSEMBLY	RIPARO - LATERALE DESTRO COMPLETO
22	79052456	1	17I	FRAME	INCASTELLATURA
23	79045509	1	70R	GUARD - FRONT ASSEMBLY	RIPARO - ANTERIORE COMPLETO
24	79052464	1	70R	GUARD - FRONT LEFT ASSEMBLY	RIPARO - ANTERIORE SINISTRO COMPLETO

OPTIONAL VARIANTE 30.0570.18.1

79043237
 CAB - CABINA - CABINE - FAHRERHAUS - CABINA

I-10

1	L1.04	1
N.T.R. 114 - 16-01-1984		
604.01.081.01		

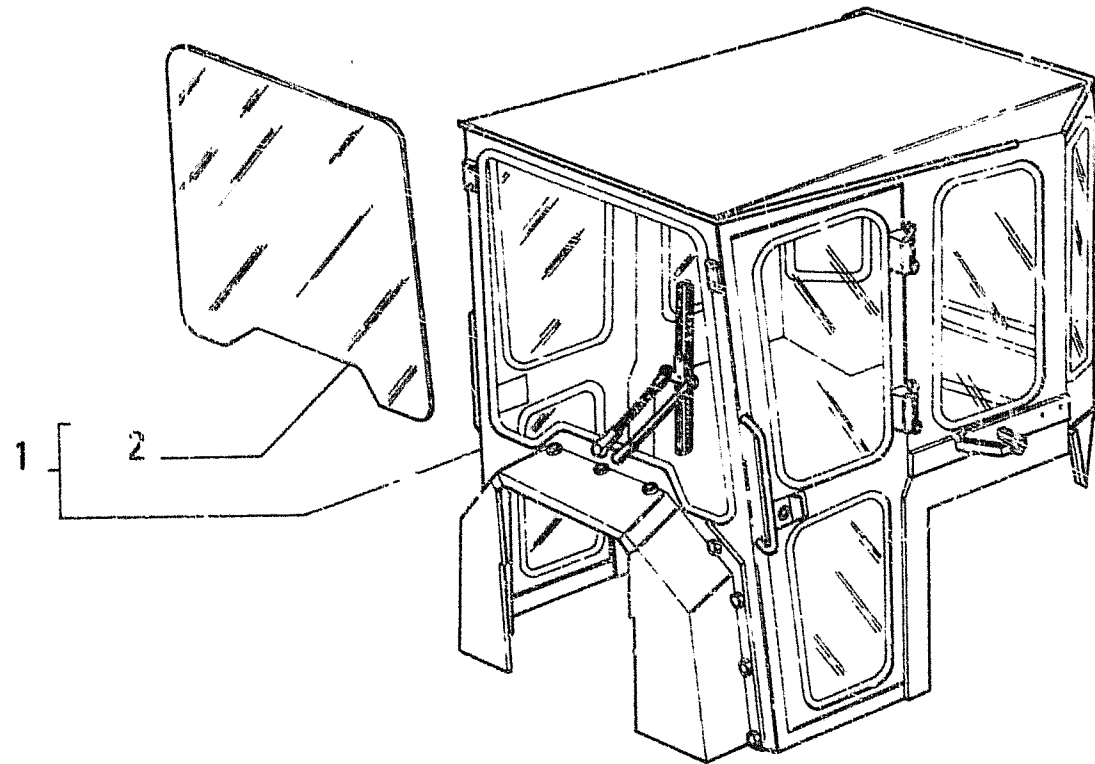

OPTIONAL
VARIANTE 30.0571.04.1

QTY	PART NUMBER	TRANS CODE	DESCRIPTION	DESCRIZIONE
1	76012112	0C	CAB - ASSEMBLY	CABINA - COMPLETO
2	76012109	315C	GLASS PANE	CRISTALLO

- FOR THE CAB MISSING COMPONENTS SEE SGR. L1.03 AND L1.04.
- PER LE RIMANENTI PARTI DELLA CABINA VEDERE I SGR. L1.03 E L1.04.

CAB AND MOUNTINGS - CABINA E SUPPORTI - CARINE ET SUPPORTS - FAHRERHAUS UND LAGER -
CABINA Y APOYOS

L1.03/1

N.T.R. 158 - 13.03.1987
604.01.081.03

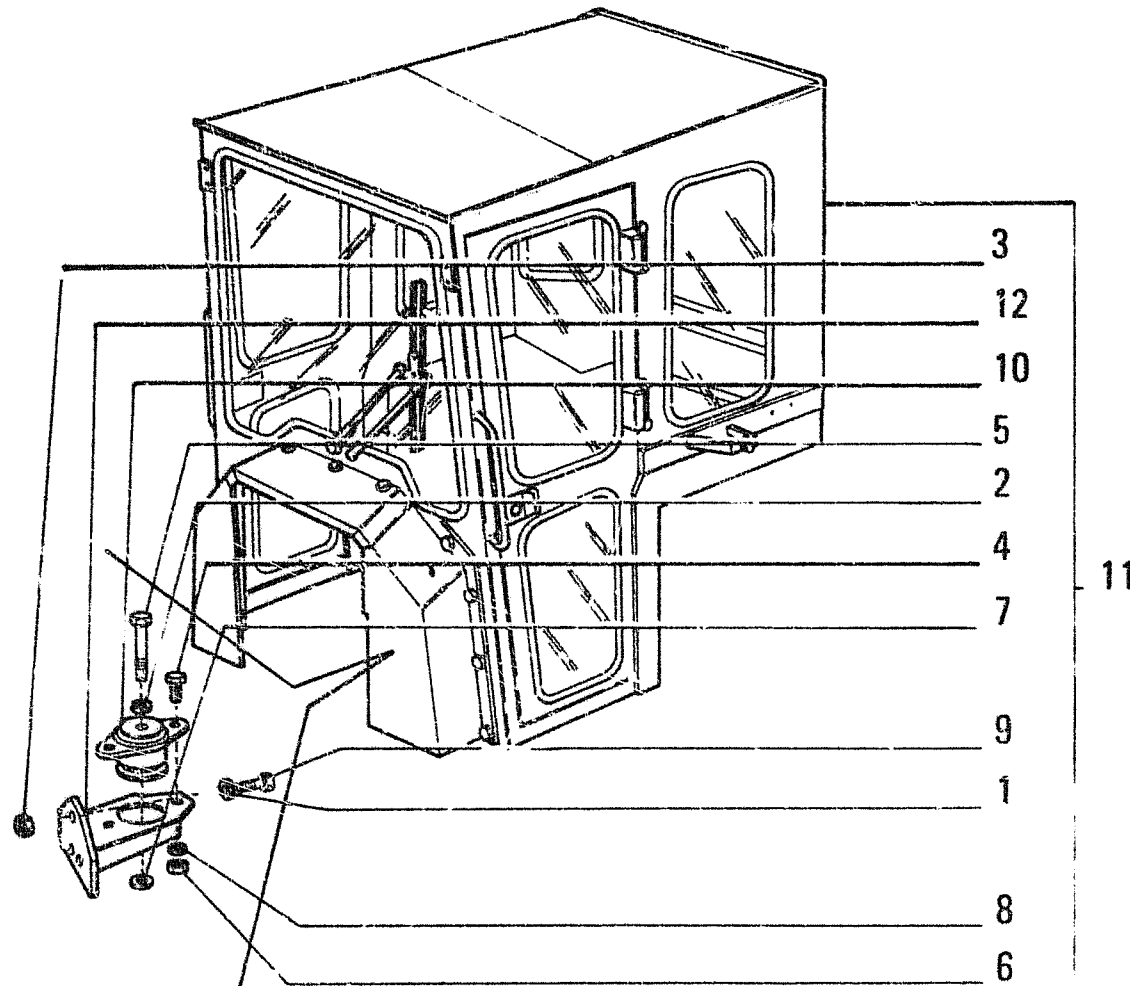

ITEM	PART NUMBER	QTY	TRANS CODE	DESCRIPTION	DESCRIZIONE
1	12638601	6	131R	WASHER 10,2x18	ROSETTA 10,2x18
2	10520201	4	131R	WASHER 16,4x28	ROSETTA 16,4x28
3	12574511	6	10D	NUT 10x1,25x12,3	DADO 10x1,25x12,3
4	11306921	8	40V	SCREW 10x1,25x30	VITE 10x1,25x30
5	11369621	4	40V	SCREW 16x1,5x110	VITE 16x1,5x110
6	12574511	8	10D	NUT 10x1,25x12,3	DADO 10x1,25x12,3
7	10572170	4	132R	LOCKWASHER 16x3,5	ROSETTA DI SICUREZZA 16x3,5
8	12638601	8	131R	WASHER 10,2x18	ROSETTA 10,2x18
9	11307021	6	40V	SCREW 10x1,25x40	VITE 10x1,25x40
10	79043349	4	155S	SILENTBLOC	SILENTBLOC
11	79043237	1	8C	CAB - ASSEMBLY SEE L1.04	CABINA - COMPLETO VEDERE L1.04
12	79052465	2	300S	SUPPORT	SUPPORTO

OPTIONAL VARIANTE 30.0570.18.:

CAB AND MOUNTINGS - CABINA E SUPPORTI - CABINE ET SUPPORTS - FAHRERHAUS UND LAGER - CABINA Y APOYOS

L1.03

N.T.R. 114 - 16-01-1984

604.01.081.01

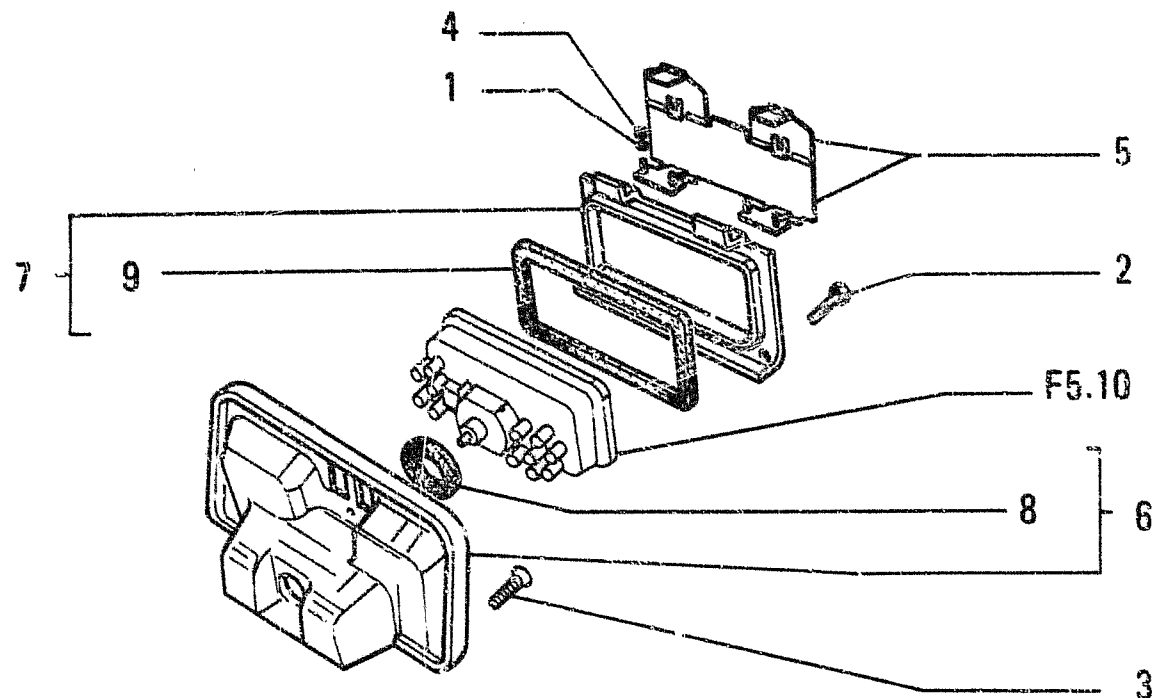

ITEM	PART NUMBER	QTY	TRANS CODE	DESCRIPTION	DESCRIZIONE
1	10516671	4	132R	LOCKWASHER (*) 8,1x2,2	ROSETTA DI SICUREZZA (*) 8,1x2,2
2	13297317	2	40V	SCREW 4x0,7x10	VITE 4x0,7x10
3	13301717	6	40V	SCREW 6x1x25	VITE 6x1x25
4	16102321	4	100	NUT (*) 8x1,25x5	DADO (*) 8x1,25x5
5	78006881	1	265C	COVER (*) D1525	COPERCHIO (*) D1525
	79043102	1	265C	COVER (*) C1525	COPERCHIO (*) C1525
6	79042406	1	141P	INSTRUMENT PANEL C1525	PLANCIA PORTASTRUMENTI C1525
	79054632	1	141P	INSTRUMENT PANEL - ASSEMBLY D1525	PLANCIA PORTASTRUMENTI - COMPLETO D1525
7	79042186	1	295C	BEZEL C1525	CORNICE C1525
	79054634	1	295C	BEZEL - ASSEMBLY D1525	CORNICE - COMPLETO D1525
8	79054635	1	120G	GASKET D1525	GUARNIZIONE PIANA D1525
9	79045510	1	120G	GASKET D1525	GUARNIZIONE PIANA D1525
(*)			469P	FOR SPECIAL EQUIPMENT 30.0843.10.i	PER VARIANTE 30.0843.10.1

HOOD ASSY - COFANATURA - CAPOTAGE - HAUBE - CAPOT

L1.01

4

N.T.R. 158 - 13.03.1987
604.01.081.03

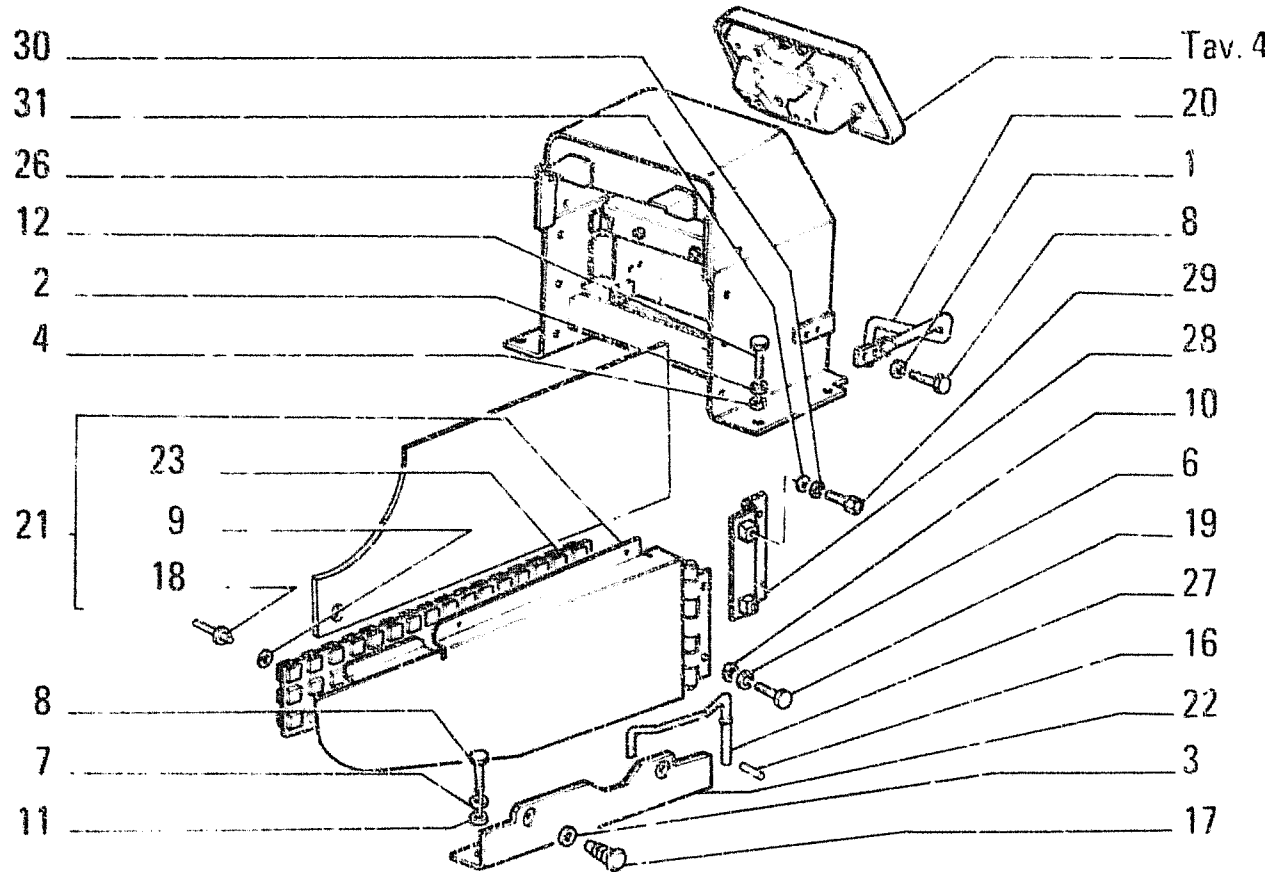

ITEM	PART NUMBER	QTY	TRANS CODE	DESCRIPTION	DESCRIZIONE
23	79039526	2	25P	PANEL (*)	PANNELLO (*)
26	79043367	1	72I	FRAME	INTELAIATURA
27	79044613	1	90A	ROD - LEFT (*) (1')	ASTA - SINISTRO (*) (1')
	79044614	1	90A	ROD - RIGHT (*) (1')	ASTA - DESTRO (*) (1')
28	79050171	2	225S	BRACKET	STAFFA
29	11112631	4	40V	SCREW 12x1,75x35	VITE 12x1,75x35
30	10571971	4	170R	LOCKWASHER 12,2x2,5	POSETTA EL 12,2x2,5
31	12646921	4	131R	WASHER 12,2x26	ROSETTA 12,2x26
	(*)		469P	FOR SPECIAL EQUIPMENT 30.0822.31 1	PER VARIANTE 30.0022.31 1
	(1')		469P	FOR SPECIAL EQUIPMENT 30.0836.12 1	PER VARIANTE 30.0836.12 1

HOOD ASSY - COFANATURA - CAPOTAGE - HAUBE - CAPOT

L1.01

3

N.T.R. 260 15 10 1990

604.01.081 05

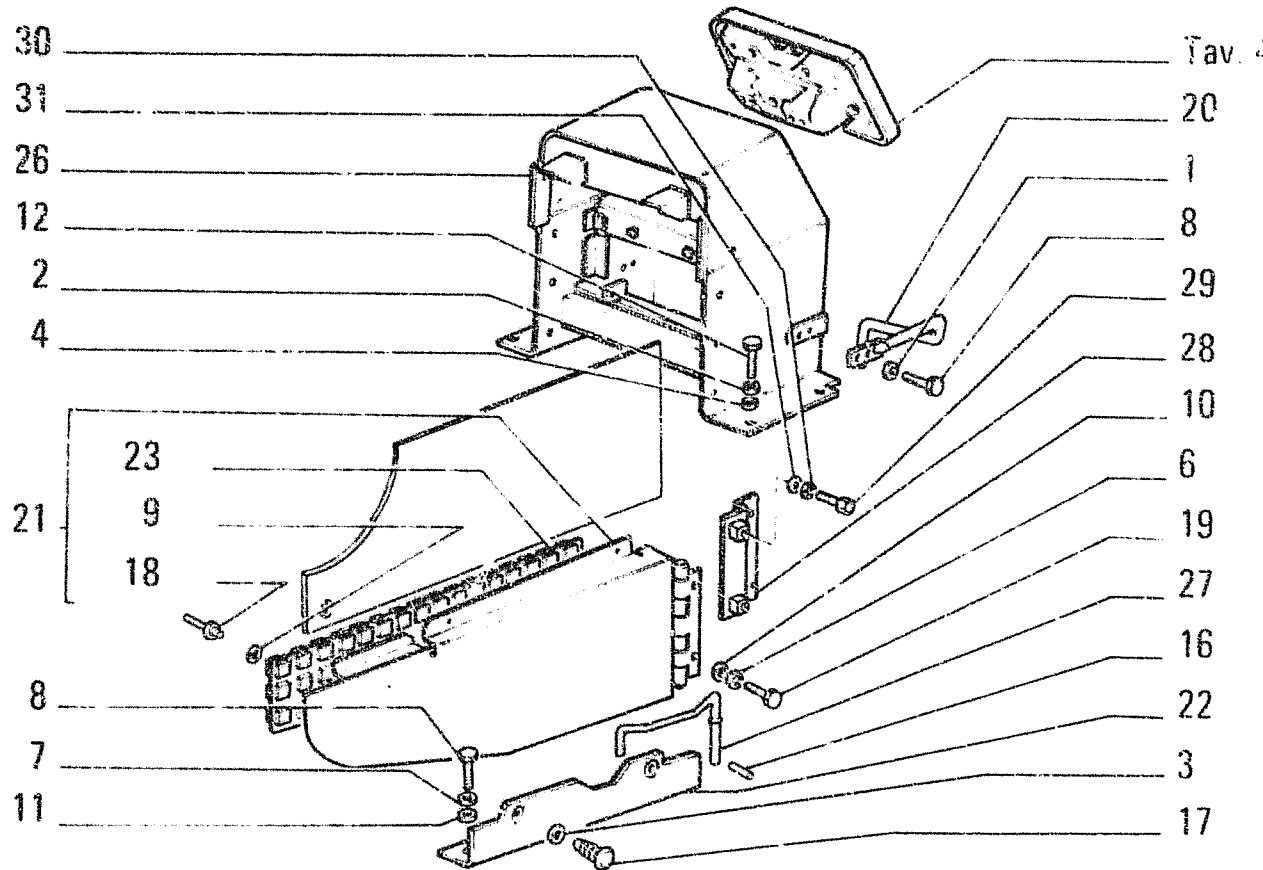

ITEM	PART NUMBER	QTY	TRANS CODE	DESCRIPTION	DESCRIZIONE
1	10516871	4	132R	LOCKWASHER 10x2,5	ROSETTA DI SICUREZZA 10x2,5
2	10517071	4	132	LOCKWASHER 12,2x3,1	ROSETTA DI SICUREZZA 12,2x3,1
3	10519421	8	131R	WASHER (*) 6,15x12	ROSETTA (*) 6,15x12
4	10520021	4	131R	WASHER 12,2x22	ROSETTA 12,2x22
6	10571771	4	132R	LOCKWASHER 8,1x2	ROSETTA DI SICUREZZA 8,1x2
7	10571871	4	132R	LOCKWASHER (*) (1") 10,2x2,2	ROSETTA DI SICUREZZA (*) (1") 10,2x2,2
8	11106231	4	40V	SCREW (*) (1") 10x1,5x25	VITE (*) (1") 10x1,5x25
9	12642801	20	131R	WASHER (*) 4,15x12,5	ROSETTA (*) 4,15x12,5
10	12646721	4	131R	WASHER 8,15x20	ROSETTA 8,15x20
11	12646821	4	131R	WASHER (*) (1") 10,2x25	ROSETTA (*) (1") 10,2x25
12	11112431	4	40V	SCREW 12x1,75x30	VITE 12x1,75x30
16	14158470	2	200S	PIN (*) (1") 2,3x10	SPINA (*) (1") 2,3x10
17	14567080	8	121B	RUBBER STUD (*) 8,5x14	BOTTONE DI GOMMA (*) 8,5x14
18	14641995	20	55R	RIVET (*) 2,3x10,4	RIBATTINO (*) 2,3x10,4
19	16043431	4	40V	SCREW 8x1,25x20	VITE 8x1,25x20
20	79027347	1	78A	FOOTREST - RIGHT	APPOGGIAPIEDE - DESTRO
	79027348	1	78A	FOOTREST - LEFT	APPOGGIAPIEDE - SINISTRO
21	79037580	1	52F	SIDE PANEL - RIGHT (1")	FIANCHETTO - DESTRO (1")
	79037583	1	52F	SIDE PANEL - LEFT (1")	FIANCHETTO - SINISTRO (1")
	79037585	1	52F	SIDE PANEL - RIGHT ASSEMBLY (*)	FIANCHETTO - DESTRO COMPLETO (*)
	79037588	1	52F	SIDE PANEL - LEFT ASSEMBLY (*)	FIANCHETTO - SINISTRO COMPLETO (*)
	79050169	1	52F	SIDE PANEL - RIGHT	FIANCHETTO - DESTRO
	79050170	1	52F	SIDE PANEL - LEFT	FIANCHETTO - SINISTRO
22	79037586	2	52F	SIDE PANEL (*) (1")	FIANCHETTO (*) (1")

HOOD ASSY - COFANATURA - CAPOTAGE - HAUBE - CAPOT

L1.01

3

N I R 200 15.10.1990

604.01.081.05

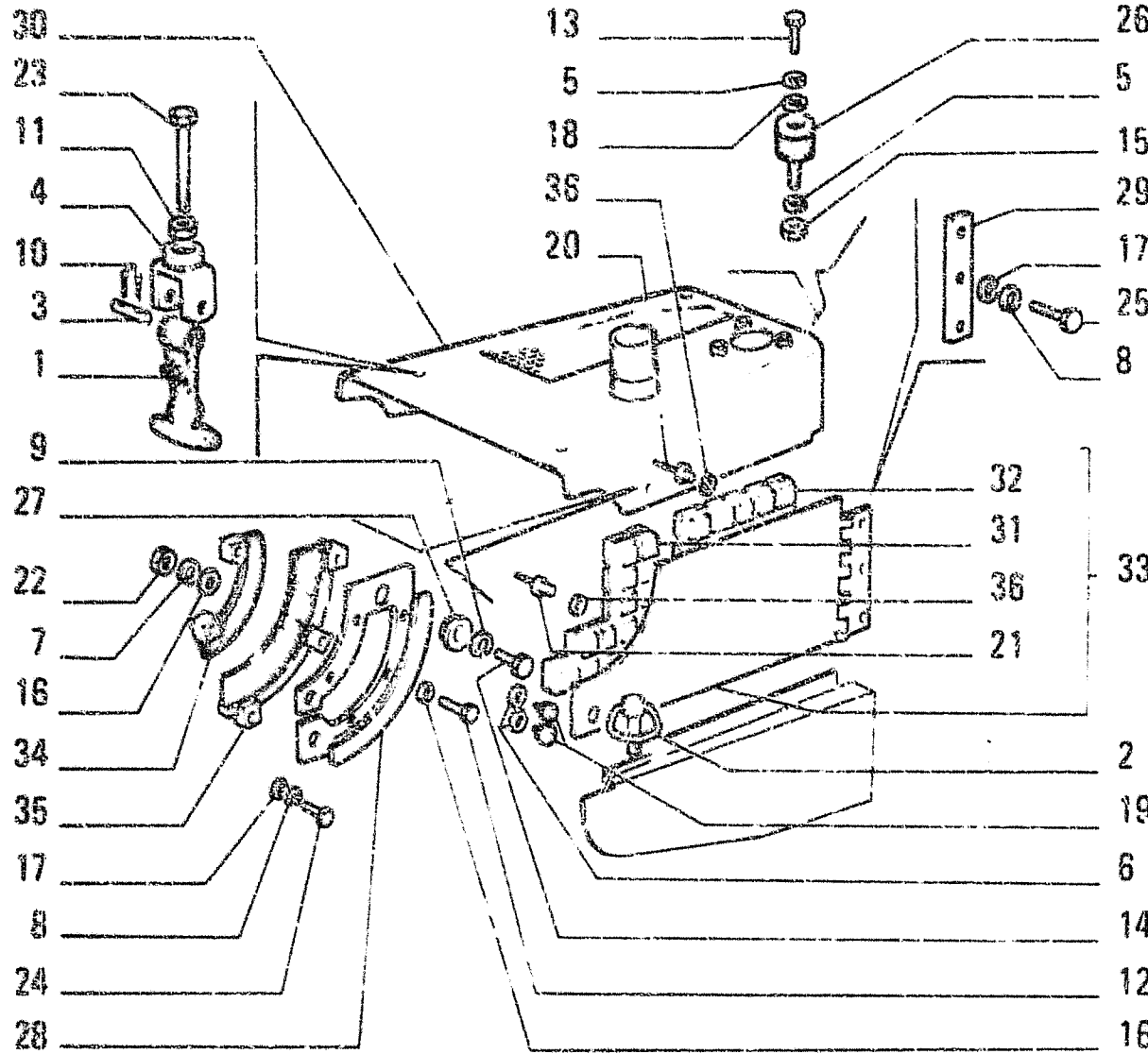

ITEM	PART NUMBER	QTY	TRANS CODE	DESCRIPTION	DESCRIZIONE
(1*)			469P	FOR SPECIAL EQUIPMENT 30.0836.12.1	PER VARIANTE 30.0836.12.1

HCOD ASSY - COFANATURA - CAPOTAGE - HAUBE - CAPOT

L1.01 2
N.T.R. 158 - 13.03.1987
604.01.081.03

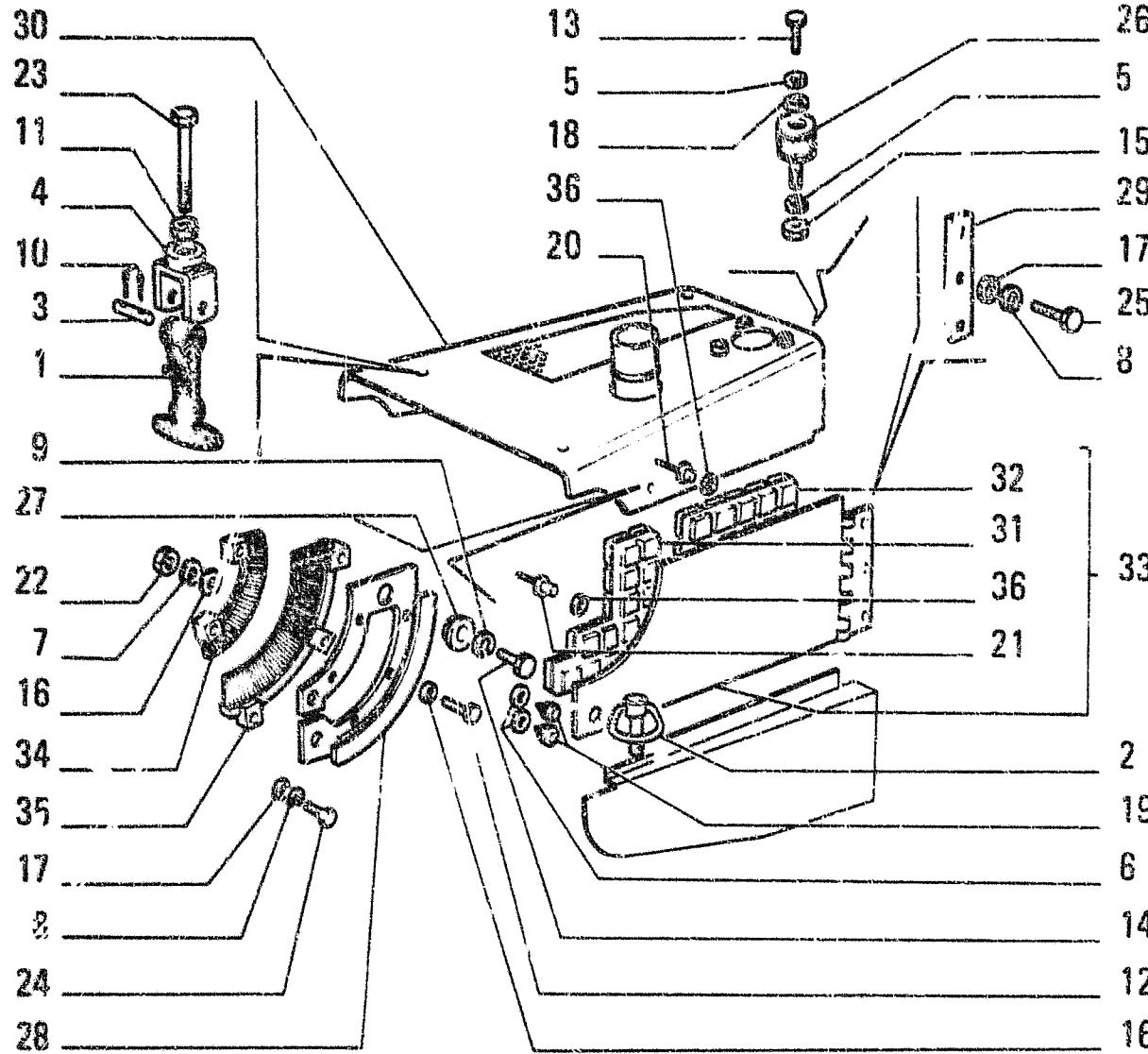

ITEM	PART NUMBER	QTY	TRANS CODE	DESCRIPTION	DESCRIZIONE
24	16043431	4	40V	SCREW (")(1") 8x1,25x20	VITE (")(1") 8x1,25x20
25	16043831	6	40V	SCREW (")(1") 8x1,25x30	VITE (")(1") 8x1,25x30
26	79038554	2	61T	CUSHION PAD	TASSELLO ELASTICO
27	79032003	2	95B	BUSHING	BODICOLA
28	79034265	1	136S	SPROCKET SECTOR - RIGHT (")(1")	SETTORE RUOTA MOTRICE - DESTRO (")(1")
	79034268	1	136S	SPROCKET SECTOR - LEFT (")(1")	SETTORE RUOTA MOTRICE - SINISTRO (")(1")
29	79034284	2	198S	SHIM (")(1")	SPESORE (")(1")
30	79034518	1	176C	HOOD	COFANO
31	79039527	1	25P	PANEL - RIGHT (")	PANNELLO - DESTRO (")
	79039529	1	25P	PANEL - LEFT (")	PANNELLO - SINISTRO (")
32	79039528	1	25P	PANEL - RIGHT (")	PANNELLO - DESTRO (")
	79039530	1	25P	PANEL - LEFT (")	PANNELLO - SINISTRO (")
33	79034278	1	52F	SIDE PANEL - RIGHT ASSEMBLY (")	FIANCHETTO - DESTRO COMPLETO (")
	79034279	1	52F	SIDE PANEL - LEFT ASSEMBLY (")	FIANCHETTO - SINISTRO COMPLETO (")
	79039532	1	52F	SIDE PANEL - RIGHT ASSEMBLY (")	FIANCHETTO - DESTRO COMPLETO (")
	79039533	1	52F	SIDE PANEL - LEFT ASSEMBLY (")	FIANCHETTO - SINISTRO COMPLETO (")
34	79047158	2	177S	BRUSH (")(1")	SPAZZOLA (")(1")
35	79047165	2	177S	BRUSH (")(1")	SPAZZOLA (")(1")
36	12642801	27	131R	WASHER (") 4,15x12,5	ROSETTA (") 4,15x12,5
			469P	FOR SPECIAL EQUIPMENT	PER VARIANTE 30.0022.31.1

HOOD ASSY - COFANATURA - CAPOTAGE - HAUBE - CAPOT

L1.01 2
 N.T.R. 158 - 13.03.1987
 604.01.081.03

DESIGN LETTER	DESIGN BASE	SAAC DESIGNATION	DESIGNATIONS-BASES	GRUNDZEICHEN-NUMMERN	RENDERILACIONES BASE
111V	VALVOLA ASPIRAZIONE	INTAKE VALVE	SOUPAPE DE ADMISSION	ENLASSVENTIL	VALVULA DE ASPIRACION
111B	BRACCIO ABBATTIMENTO (AD)		BRAS ABATTAGE (AD)	ABBRUCHARM (AD)	
111D	BRACCIO ABBATTIMENTO (BD)		BRAS ABATTAGE (BD)	ABBRUCHARM (BD)	
112C	CAVO MASSA	GROUND CABLE	FIL DE MAS	MASSKABEL	CABLE DE MASA
112F	FUSO A SNGCO	STEERING KNUCKLE	FUSEE	ACHSSCHENKEL	PUNTA DE EJE
112P	PIASTRINA ISOLANTE	INSULATING PLATE	PLAQUETTE ISOLANTE	ISOLIERUNG	PLACA AISLANTE
112S	SEPARATORE D'ARIA E VAPORE	AIR AND STEAM SEGREGATOR	SEPARATEUR D'AIR ET DE VAPEUR	LUFT-UND DAMPFABSCHEIDER	SEPARACION DE AIRE Y VAPORE
112V	VALVOLA SCARICO	EXHAUST VALVE	SOUPAPE D'ECHAPPEMENT	AUSLASSVENTIL	VALVULA DE DESCARGA
1120	PIASTRA DI SPINTA PER AD		PLAQUE DE POUSSÉE POUR AD	SCHUBPLATTE (AD)	
1124	TILT IDRAULICO (HA)	HYDRAULIC TILT (HA)	TILT HYDRAULIQUE (HA)	HYDR.TILTVERSTELLUNG (HA)	TILT HIDRAULICO (HA)
1128	TILT-PITCH (HA)	TILT-PITCH (HA)	TILT-PITCH (HA)	TILT-PITCH (HA)	
113B	BOZZELI O CARRUCOLA	SHEAVE BLOCK	POULIE	FLASCHENRUG	GARRUCHA
113F	FUSO	STUB SHAFT	FUSEE	ACHSSCHENKEL	MANGUETA
113G	GUANTI	GLOVES	GANTS	HANDSCHUHE	GUANTES
113M	MONOLEVA	SINGLE LEVER	LEVIER UNIQUE	EINHEBELHEBUNG	MONOPALANCA
113P	PIASTRINA DI SICUREZZA	LOCKPLATE	PLAQUETTE FREIN	SICHERUNGSBLECH	CHAPITA DE SEGURIDAD
113S	SERBATOIO OLIO	OIL RESERVOIR	RESERVOIR D'HUILE	ÖLTANK	DEPOSITO ACEITE
113T	TESTA CILINDRI	CYLINDER HEAD	CULASSE DE CYLINDRE	ZYLINDERKOPF	TAPA DE CILINDROS
113V	VALVOLA DI ANTICIPO	ADVANCE VALVE	SOUPAPE D'AVANCE	REGELVENTIL	VALVULA DE AVANCE
1130	ATTACCO RAPIDO				
113E	PIASTRA DI SPINTA PER BD		PLAQUE DE POUSSÉE POUR BD	SCHUBPLATTE (BD)	
1136	TILT-PITCH	TILT-PITCH	TILT-PITCH	TILT-PITCH	
114P	PIASTRINA DI COMANDO	DRIVE LINK	PLAQUE DE COMMANDE	MITNEMER	PLACA DE ARRASTRE
114S	SERBATOIO COMBUSTIBILE	FUEL TANK	RESERVOIR DE COMBUSTIBLE	KRAFTSTOFFTANK	TANQUE COMBUSTIBLE
115G	GUARDONE PER BENNA	SPILL GUARD	REHAUSSE DE GODET	SCHAUFEL-AUFSETZWAND	PLACA DE EXTENSION DEL CUCHARON
115G					
115M	MONTANTE	PILLAR	MONTANTE	SAEULE	MONTANTE
115S	SERBATOIO	TANK	RESERVOIR	TANK	DEPOSITO
116M	MONTANTO	STEP PLATE	MARCHEPIED	TRITTBLECH	ESTRIBO
116R	RIVESTIMENTO	COVERING	RETEMENT	VERKLENNUNG	REVESTIMIENTO
116S	SERBATOIO CON VALVOLE	RESERVOIR W/VALVE	RESERVOIR ET SOUPAPE	BEHAELTER MIT WENTIL	DEPOSITO CON VALVULAS
116S					
116T	TESTA DEL GIUNTO SFERICO	SOCKET	JOINT A ROTULE	KUGELPAWNE	ARTICULACION DE ROTULA
116T					
116D	BLOCCAGGIO BRACCI	BOOM LOCK	BLOCAGE BRAS	HUBARMARRETIERUNG	ANCLAJE DE BRAZO
116I	BLOCCAGGIO BENNA	BUCKET LOCK	BLOCAGE DU GODET	SCHAUFELARRETIERUNG	ANCLAJE DE LA CUCHARA
117R	RIVESTIMENTO ISOLANTE	INSULATION	RETEMENT ISOLANT	ISOLIERUNG	FORRO AISLANTE
117S	SERBATOIO A DEPRESSIONE	VACUUM TANK	RESERVOIR DEPRESSEUR	UNTERDRUCKBEHALTER	DEPOSITO DE VACIO
117S					

DEGNOMAZIONE BASE	BASIC DESIGNATION	DESIGNATIONS-BASES	NUMEROSI-VERSIONI	DENOMINACIONES BASE	
1170	INDICATORE POSIZIONE REEHA	BUCKET LEVEL INDICATOR	MISE A NIVEAU DU GODET	SCHAUFELSTELLUNGSANZEIGER	NIVELACION DE LA CUCHARA
1171	POSIZIONATORE AUTOMATICO BENNA	BUCKET LEVELER	MISE A NIVEAU AUTOMAT GOUET	AUTOMAT.SCHAUFEL-RIECKSTELLUNG	NIVELACION AUTOMATICA CUCHARA
1167	PLACCHINA MAGNETICA	MAGNETIC PLAQUE	PLAQUETTE MAGNETI- QUE	MAGNETBLECH	ISMAN
118P					
1185	SERRAFILO	TERMINAL SCREW	SERRE-FIL	ANSCHLUSSELENDE	BORNE
1181	DISPOSITIVO LOCK-OUT	DOOR LOCK-OUT	ARRET AUTOMATIQUE BRAS	AUTOMAT.NUBAR-SONALTUNG	LIMITE AUTOMATICO DEL BRAZO
119M	MORSETTIERA	CONNECTION BLOCK	PLAQUE DE JONCTION	KLENNLEISTE	CAJA DE CONTACTOS
119T	TESTA	HEAD	TETE	KOPF	CABEZA
120A	AUTOPILOTA	AUTOPILOT	AUTOPILOTE	SCHALTSTEUERGRUPPE	AUTOPILOTO
120B	BUTTONE	BUTTON	BOUTON	KN-OPF	BOTON
120G	GUARNIZIONE MANA	GASKET	JOINT	FLACHDICHTUNG	GUARNICION
120M	MORSETTO ELETTRICO	TERMINAL CONNECTOR	BORNE	KABELLEMMER	AGARRADERA
120P	PIATTIELLO	PLATE	COUPELLE	TILLERSCHNEIBE	PLATILLO
120R	ROCCETTO	REEL	BOBINE	ZUENDSPULE	BOBINA
120S	SERRATURA	LOCK	SERRURE	SCHLOSS	CERRADURA
120T	TESTA DI REGISTRO	ADJUSTING SLEEVE	EMBOUT DE REGLAGE	EINSTELLBUCHSE	TUERCA DE REGLAJE
120J	BRACCI CARICATORE LUNGI	LONG BOOM	BRAS LONG	LAMBER LADEARM	
121B	BOTTONE DI GOMMA	RUBBER STUD	BOUTON CAOUTCHOUC	GUMMIWOLZEN	PITON DE CAUCHO
121C	CHIUSURA LAMPO	CLIDE FASTENER	FERMETURE EGLAIR	REISSVERSCHLUSS	CIERRE DE CREMA- LLERA
121C					
121M	MORSETTO A MANO	HAND VICE	ETAU A MAIN	KLEMMBACKE	TORNILLO DE MANO
121P	PIATTIELLO DELLA PUNTERIA	TAPPET PLATE	PASTILLE DE POUSSOIR	DISTANZSCHEIBE	PLATILLO DE EMPU
121P					
121S	SEPARATORE DI CONDENSA	WATER SEGREGATOR	SEPARATEUR D'EAU CONDENSEE	KONDENSWASSER- ABSCHIEDER	SEPARADOR DE AGUA
121S					
122F	FINO AL MOTORE IDRAULICO...	UP TO HYDRAULIC MOTOR...	JUSQU'AU MOTEUR HYDRAULIQUE	BIS HYDRAULIKMOTOR...	HASTA EL MOTOR HIDRAULICO...
122G	GUARNIZIONE	SEAL	GARNITURE	DICHTUNG	GUARNICION
122P	PIGNONE	PINION	PIGNON	RITZEL	PINON
123F	FINO AL RIDUTTORE...	UP TO REDUCTION GEAR...	JUSQU'AU REDUCTEUR...	BIS UNTERSETZUNGSGETRIEBE...	HASTA EL REDUCTOR...
123G	GUARNIZIONE TERRUTA FRONTALE	SEAL ASSY	GARNITURE FRONTAL	LIFE TIME-DICHTUNG	SELLO
123P	PIGNONE CONICO	BEVEL PINION	PIGNON CONIQUE	KEGELRITZEL	PINON CONICO
123S	SERVOCOMANDO	SERVO-CONTROL	SERVO-COMMANDE	SERVOSTEUERUNG	SERVOMANDO
124B	BRACCIOLO SEDILE	ARMREST	ACCOUDOIR DE SIEGE	ARMLEHNE	APOYABRAZO
124F	FINO AL ...	UP TO ...	JUSQU'AU .	BIS ...	HASTA EL ...
124M	MOTOPOMPA	MOTOR PUMP	POMPE A MOTEUR	PUMPENAGGREGAT	BOMBA DE MOTOR
124P	PIEZA AUTOCENTRANTE	COLLET	PINCE FENDUE	SPANNZANGE	PASADOR DE MUELLE
124S	SERVODISTRIBUTORE	SERVO-VALVE	SERVO-DISTRIBUTEUR	VORSTEUERVENTIL	SERVOVALVULA
125F	FORCA	FORK			
125P	PIEZA	PLIERS	PINCES	ZANGE	ALICATES
125S	SERVOFRENO	BRAKE BOOSTER	SERVO-FREIN	SERVOSREMSE	SERVOFRENO

	DESIGNAZIONE BASE	BASIC DESIGNATION	DESIGNATIONS-BASES	GRUNDEZEICHNUNGEN	DENOMINACIONES BASE
126F	FINO ALLA POMPA ...	UP TO PUMP ...	JUSQU'A LA POMPE ...	BIS PUMPE...	HASTA LA BOMBA ...
126P	PISTA FRENO	CALIPER	ETRIER DE FREIN	BREMSZANGE	ZAPATA DE FRENO
126S	SERVORRIZIONE	CLUTCH-SERVO	SERVO-EMBAYAGE	SERVOKUPPLUNG	SERVOEMBRAQUE
127M	MOTORE IDRAULICO	HYDRAULIC MOTOR	MOTEUR HYDRAULIQUE	HYDRAULIKMOTOR	MOTOR HIDRAULICO
127P	POMBO	LEAD SEAL	PLOMB	PLOMBE	FRECINTO
127S	SERVOFRENO PNEUMO-IDRAULICO	AIR-HYDRAULIC ASSISTED BRAKE	SERVO-FREIN HYDRO-PNEUMATIQUE	HYDROPNEUMATISCHE SERVOBREMSE	SERVOFRENO NEUMO-HIDRAULICO
127S	TUBAZ. E COMANDO ATTREZZO ANT	FRONT ATTACH PIPING AND CONTR	TUYAUTERIE ET C.DE OUTIL AV.	FRONTGERAET LEITUNGEN-STEUERUM	
1280	TUBAZIONI POST (DAL DEVIATORE)	REAR PIPE (FROM DIVERTER VALV)		LEITUNGEN HINTER(VOM UMSCHATTV	
1281	TUBAZIONI POST (DAL DISTRIB)	REAR PIPE (FROM CONTROL VALVE)		LEITUNGEN HINTER(VOM STEUERVERN	
128B	TUBAZIONI ATTREZZO ANT	FRONT ATTACHEMENT PIPING	CONDUITES D'OUTIL AVANT	FRONTLEITUNGEN	TUBERIA DEL UTIL ANTERIOR
129P	PISTA	RACE	PISTE	LAUFRING	PISTA
130S	BRACCIO	ARM	BRAS	ARM	BRAZO
130G	CENTRALINA	CONTROL UNIT	DISPOSITIVE DE COMMANDE	EL.STEUERPLATTE	CENTRAL
130F	FUNZIONE IDRAUL SUPPL	ADDITIONAL HYDRAULIC FUNCTION			
130M	MOTORE TERMICO	ENGINE	MOTEUR	MOTOR	MOTOR
130P	PISTONCINO	PLUNGER	PISTON	KOLBEN	EMBOLO DE VALVOLA
130S	SERVOSTERZO	SERVOSTEERING	SERVODIRECTION	SERVOLENKUNG	SERVODIRECCION
130T	TESTATA	END PLATE	CULASSE	KOPFSTUECK	TAPA
131F	FIRE SLEEVE	FIRE SLEEVE			
131R	ROSETTA	WASHER	RONDELLE	UNTERLEGSSCHEIBE	ARANDELA
131T	TESTATA CASSONE	END GATES	HAYON	STIRNWAND	TESTERO
132B	BRACCIO OSCILLANTE	SWINGING ARM	BALANCIER	SCHWINGARM	BRAZO OSCILANTE
132F	FONDELLO ANT	HEAD	BOUT AVANT	BODENTELLER	TAPA ANTERIOR
132P	PISTONE	PISTON	PISTON	KOLBEN	EMBOLO
132R	ROSETTA DI SICUREZZA	LOCKWASHER	RONDELLE FREIN	SICHERUNGSRING	ARANDELA DE FRENO
132S	SENSORE	INDUCTIVE PROXIMITY SWITCHES	CAPTEUR	SENSOR	SENSORIO
133B	BRACCIO SOLLEVAMENTO	LIFT BOOM	GRAS DE LEVAGE	HUBARM	BRAZO LEVANTAMIENTO
133F	FONDELLO POST	BOTTOM	BOUT ARRIERE	BODENTELLER	TAPA POSTERIOR
133M	MOTORINO AVVIAMENTO	STARTER MOTOR	DEMARREUR	ANLASSER	MOTOR DE ARRANQUE
133R	ROSETTA DI TENUTA	SEAL	JOINT D'ETANCHEITE	DICHTRING	JUNTA HERMETICA
134M	MOTORINO	MOTOR	MOTEUR	MOTOR	MOTOR
135C	CERCHIO RUOTA	RIM	JANTE	FELGE	LLANTA
135M	MOZZO	HUB	MOYEU	NABE	CUBO
135P	PLAFONIERA	CEILING LAMP	PLAFONNIER	DECKENLEUCHE	PANTALLA
136S	SETTORE DENTATO	TOOTHED SECTOR	SECTEUR DENTEE	ZAHNSEGMENT	SECTOR RUEDA DENTADA
136S	SETTORE RUOTA MOTRICE	SPROCKET SECTOR	SECTEUR BARBOTIN MOTEUR	ANTRIEBSRADSEGMENT	SECTOR RUEDA MOTRIZ
137M	MOTORINO ELETTRICO	ELECTRIC MOTOR	MOTEUR ELECTRIQUE	ELEKTROMOTOR	MOTOR ELECTRICO
138S	SETTORE DI RIFERIMENTO	REFERENCE SECTOR	SECTEUR DE REFERENCE	RASTENPLATTE	PLACA DE REFERENCIAS

L

BODY • CARROZZERIA • CARROSSERIE • AUFBAU • CARROCERIA

L1

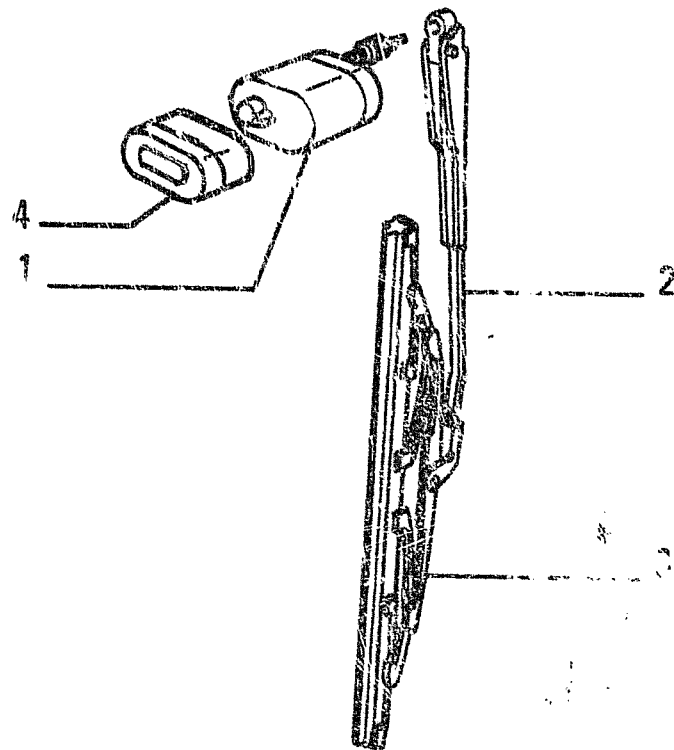

ITEM	PART NUMBER	QTY	TRANS CODE	DESCRIPTION	DESCRIZIONE
1	70738582	1	137M	ELECTRIC MOTOR	MOTORINO ELETTRICO
2	79038338	1	130b	ARM	BRACCIO
3	79050331	1	177S	BRUSH	SPAZZOLA
4	70738688	1	224P	SHIELD	PROTEZIONE

OPTIONAL
VARIANTE 30.0570.18 1

79043237

CAB - CABINA - CABINE - FAHRERHAUS - CABINA

L1.04

8

N.T.R. 158 - 13.03.1987
604.01.081.03

L2

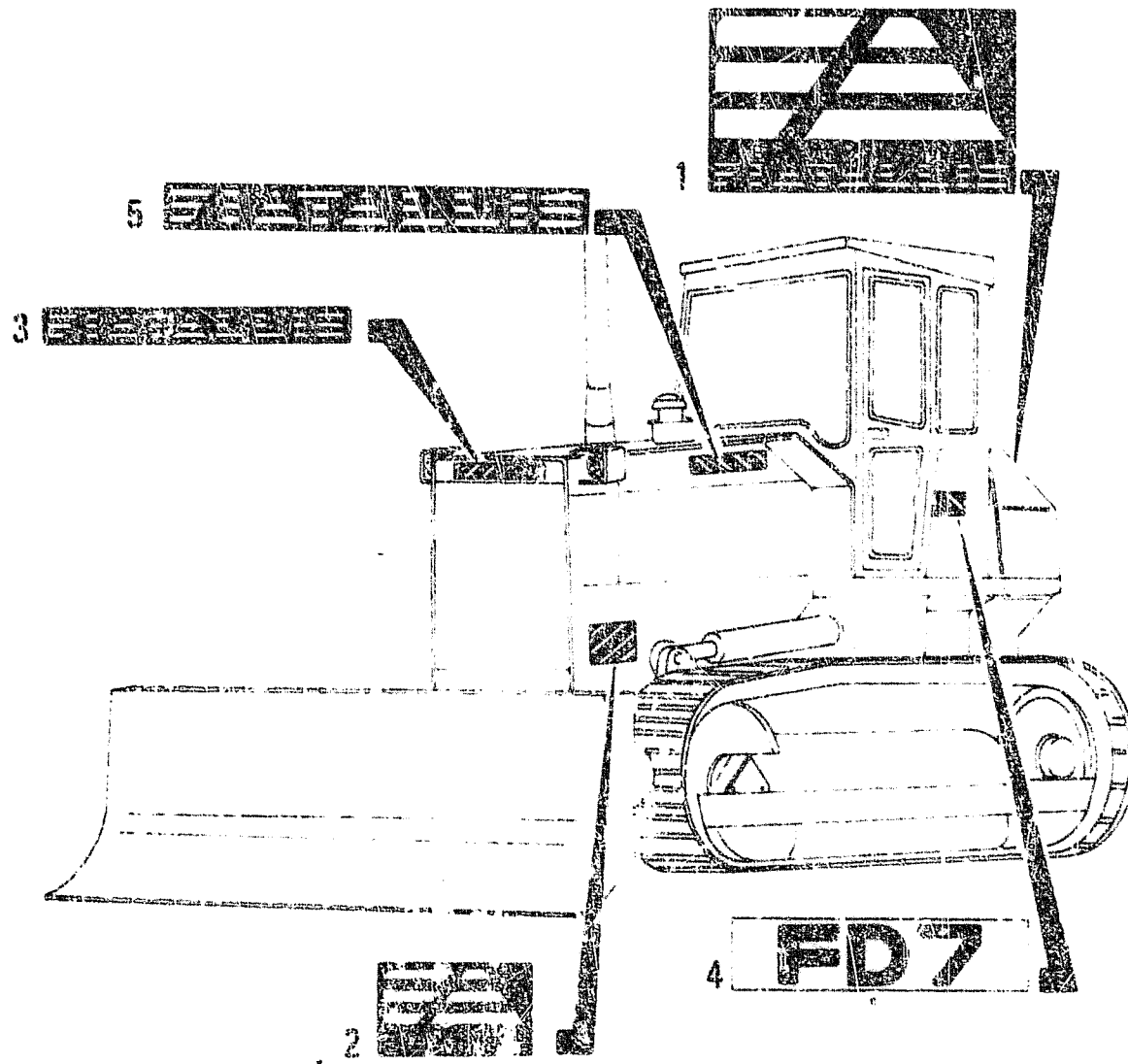

ITEM	PART NUMBER	QTY	TRANS CODE	DESCRIPTION	DESCRIZIONE
1	71308808	1	150S	TRADE MARK - REAR	SIGLA - POSTERIORE
2	79041020	2	150S	TRADE MARK - SIDE	SIGLA - LATERALE
3	79041021	3	150S	TRADE MARK - FRONT	SIGLA - ANTERIORE
4	79041135	2	151S	TYPE PLATE	SIGLA TRATTORE
5	79041164	2	150S	TRADE MARK - SIDE	SIGLA - LATERALE

TYPE PLATE - SIGLE MODELLI - MOTIF - MODELLZEICHEN - EMBLEMA

L1.25

L3

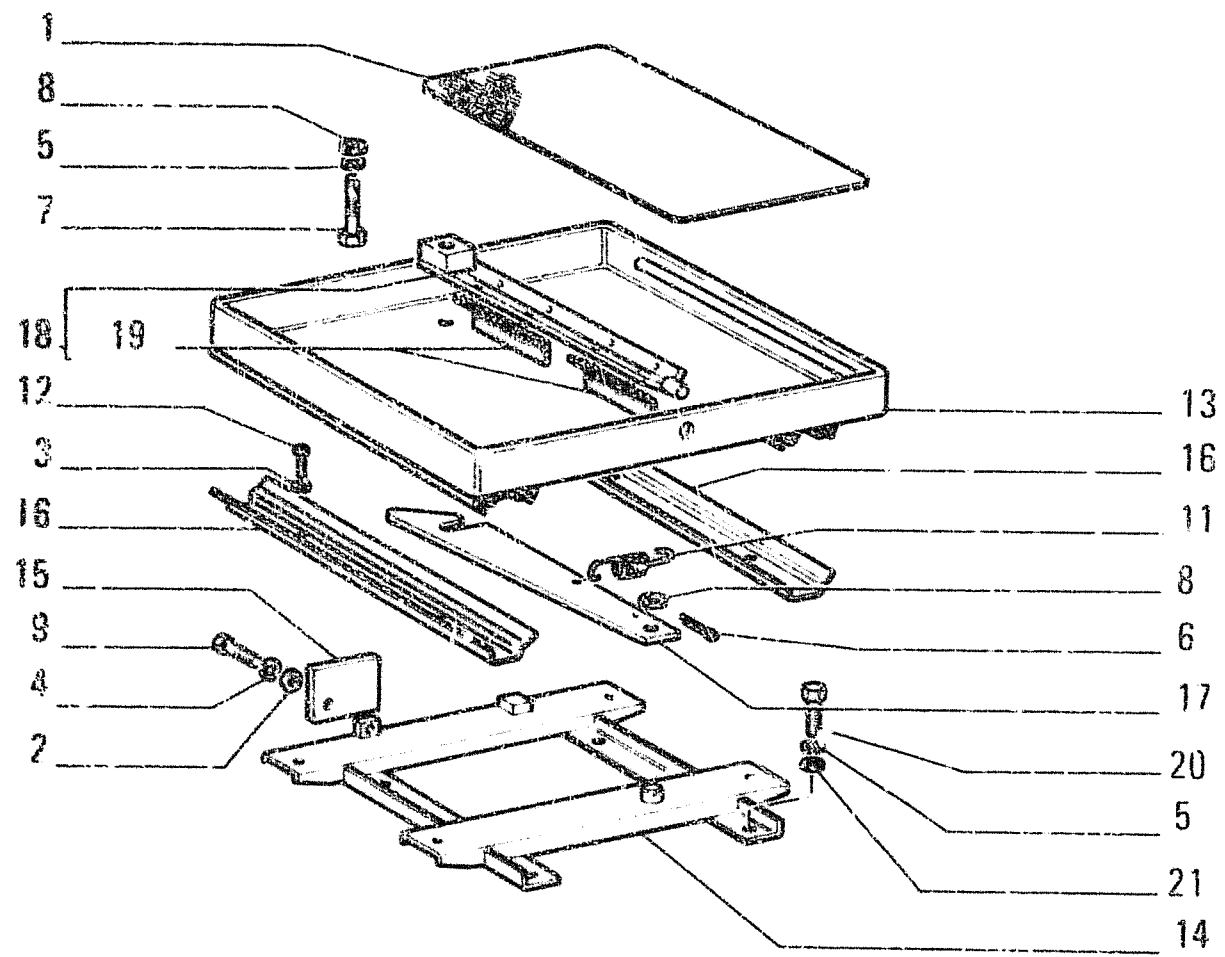

I T E M	PART NUMNER	Q T Y	TRANS CODE	DESCRIPTION	DESCRIZIONE
1	4991458	2	105P	PLATE	PIASTRA
2	10519621	1	131R	WASHER 8,45x17	ROSETTA 8,45x17
3	10569371	4	132R	LOCKWASHER 8,1x2	ROSETTA DI SICUREZZA 8,1x2
4	10571771	1	132R	LOCKWASHER 8,1x2	ROSETTA DI SICUREZZA 8,1x2
5	10571871	5	132R	LOCKWASHER 10,2x2,2	ROSETTA DI SICUREZZA 10,2x2,2
6	10796401	1	270C	COTTER PIN 2,7x27,6	COPIGLIA 2,7x27,6
7	11107231	1	40V	SCREW 10x1,5x50	VITE 10x1,5x50
8	12638621	2	131R	WASHER 10,2x18	ROSETTA 10,2x18
9	16043431	1	40V	SCREW 8x1,25x20	VITE 8x1,25x20
11	79005934	1	130M	SPRING	MOLLA
12	79010350	4	40V	SCREW	VITE
13	79025247	1	300S	SUPPORT	SUPPORTO
14	79025250	1	300S	SUPPORT	SUPPORTO
15	79025273	1	231S	CLIP	STAFFETTA
16	79025274	2	145G	GUIDE	GUIDA
17	79025276	1	45L	LEVER	LEVA
18	79033907	1	225S	BRACKET - ASSEMBLY	STAFFA - COMPLETO
19	79035712	2	61T	CUSHION PAD	TASSELLO ELASTICO
20	10979231	4	40V	SCREW 10x1,5x16	VITE 10x1,5x16
21	12646821	4	131R	WASHER 10,2x25	ROSETTA 10,2x25

C1576 → tel. n. 250884

AUXILIARY ARRANGEMENTS - INTELAIATURE PER SISTEMAZIONI VARIE - AMENAGEMENTS DIVERS
 VERSCHIEDENE GESTELLRAHMEN - SOPORTES VARIOS

L1.30
 N.T.R. 158 - 13.03 1987
 604.01.081.03



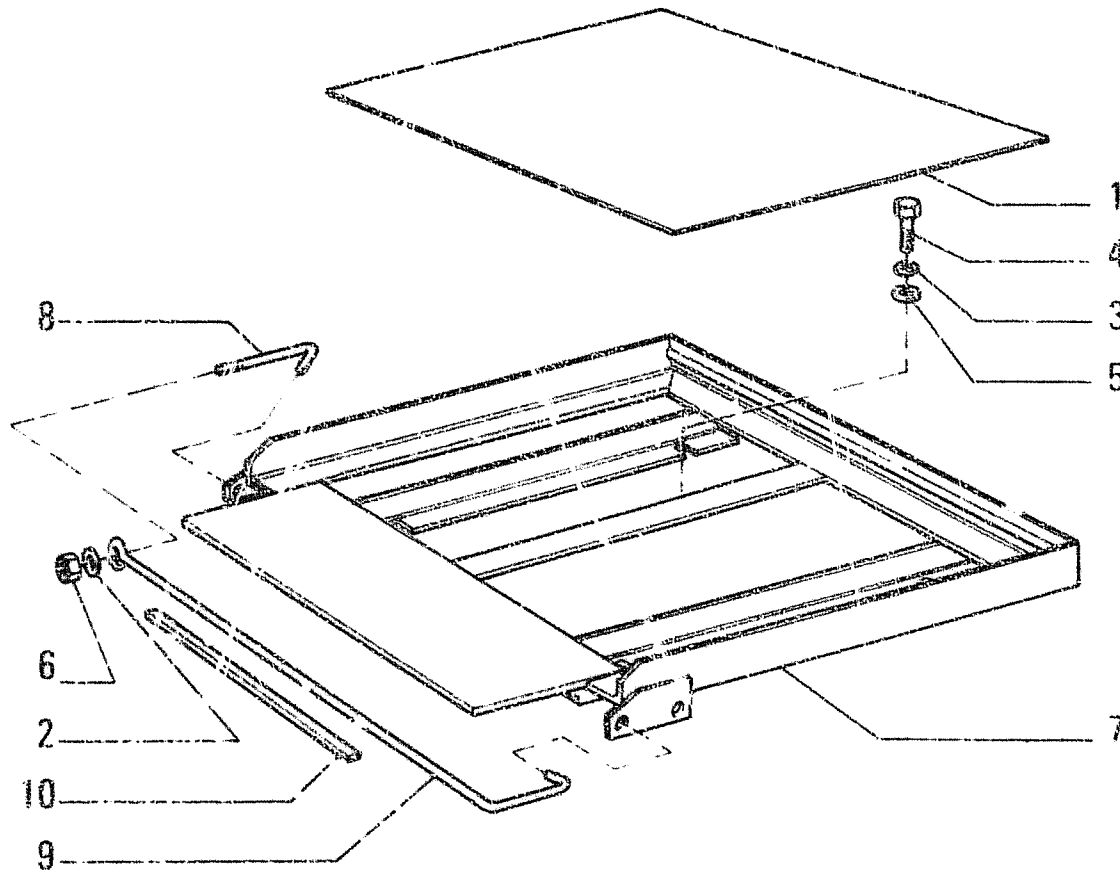

QTY	PART NUMBER	TRANS CODE	DESCRIPTION	DESCRIZIONE
1	4991458	2 105P	PLATE	PIASTRA
2	10519621	1 131R	WASHER 8,45x17	ROSETTA 8,45x17
3	10571871	4 17GR	LOCKWASHER 10,2x2,2	ROSETTA EL. 10,2x2,2
4	10979231	4 40V	SCREW 10x1,5x16	VITE 10x1,5x16
5	12646821	4 131R	WASHER 10,2x25	ROSETTA 10,2x25
6	16104411	1 10U	NUT 8x1,25x8,5	DADO 8x1,25x8,5
7	76011184	1 300S	SUPPORT	SUPPORTO
8	76011194	1 142T	TIEROD	TIRANTE
9	76012946	1 142T	TIEROD	TIRANTE
10	79064308	2 61T	CUSHION PAD	TASSELLO ELASTICO

D1576 tel. n. 250885 →

AUXILIARY ARRANGEMENTS - INTELAIATURE PER SISTEMAZIONI VARIE - AMENAGEMENTS DIVERS -
 VERSCHIEDENE GESTELLRAHMEN - SOPORTES VARIOS

L5

L1.30/A

N.T.R. 158 - 13.03.1987
 604.01.081.03

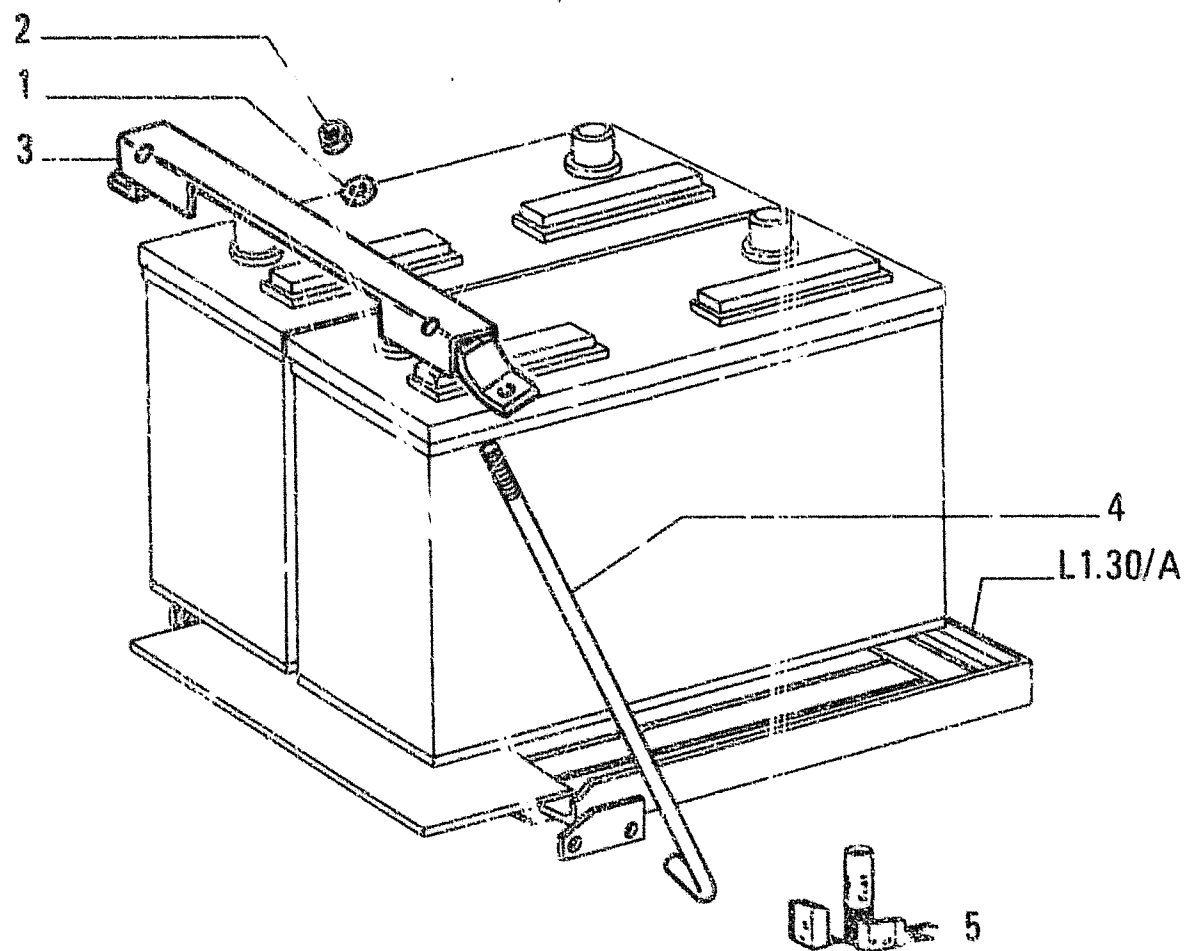

FANA VERSION
ALLESTIMENTO FANA

ITEM	PART NUMBER	QTY	TRANS CODE	DESCRIPTION	DESCRIZIONE
1	12646621	2	131R	WASHER (*) (1")	ROSETTA (*) (1")
2	15896221	2	10D	NUT (*) (1") 6x1x5	DADO (*) (1") 6x1x5
3	76015769	1	225S	BRACKET (*) C2949	STAFFA (*) C2949
	76017076	1	225S	BRACKET (*) (1") D2949	STAFFA (*) (1") D2949
4	76015770	2	142T	TIEROD (*) C2949	TIRANTE (*) C2949
	76017079	2	142T	TIEROD (*) (1") D2949	TIRANTE (*) (1") D2949
5	73153575	1	1K	KIT SEE PAGE 9 (*) C3212	KIT VED. PAG.9 (*) C3212
	76019926	1	1K	KIT SEE PAGE 9 (1") D3212	KIT VED. PAG.9 (1") D3212
(*)				469P FOR SPECIAL EQUIPMENT 76016158	PER VARIANTE 76016158
(1")				469P FOR SPECIAL EQUIPMENT 30.9116.08.1	PER VARIANTE 30.9116.08.1

AUXILIARY ARRANGEMENTS - INTELAIATURE PER SISTEMAZIONI VARIE - AMENAGEMENTS DIVERS -
VERSCHIEDENE GESTELLRAHMEN - SOPORTES VARIOS

L1.30/1

N.T.R. 200 - 15.10.1990

604.01.081.05

L6

L3.08

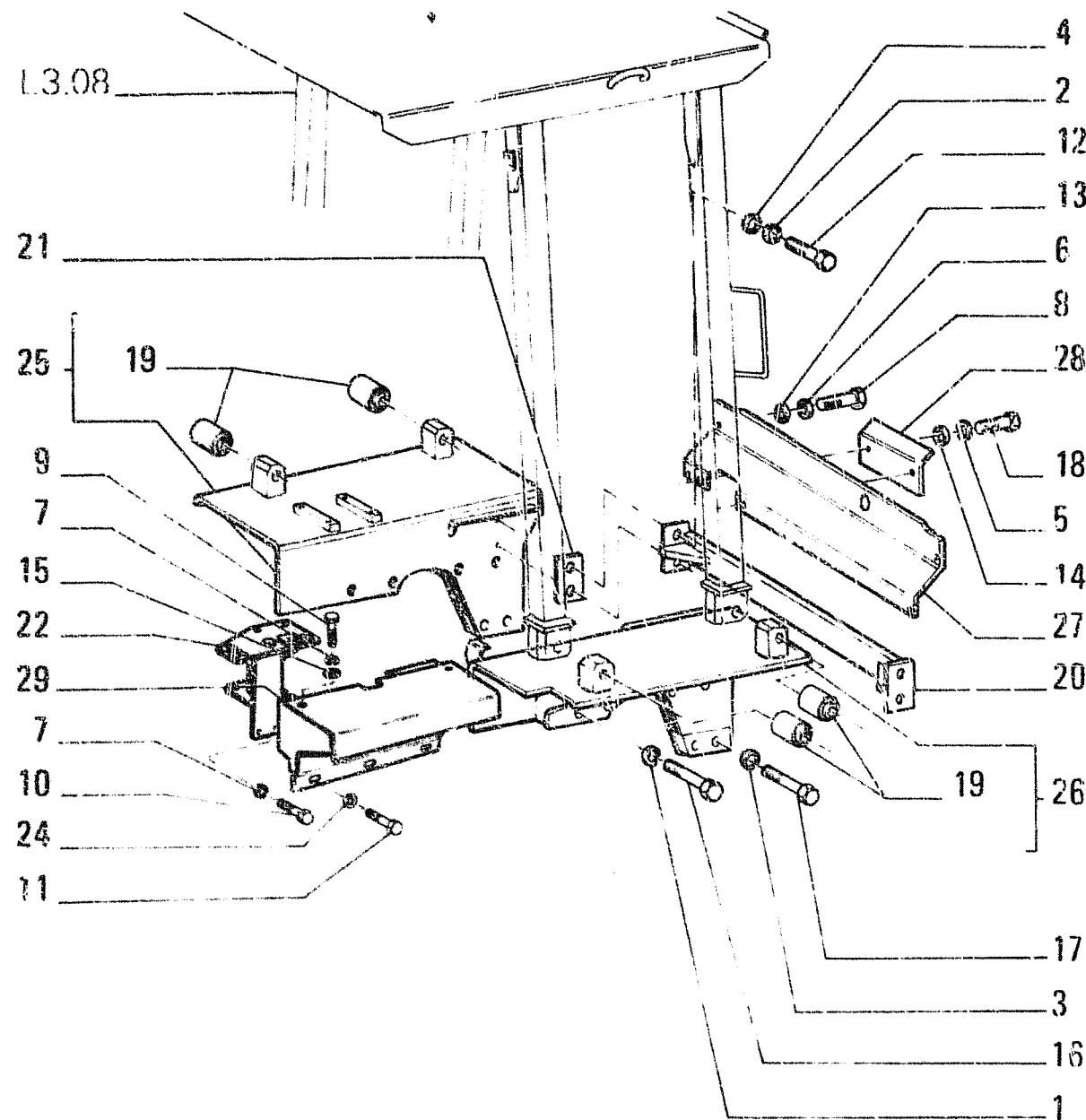

FIATALLIS /07

L3.04 TAV. 1 PAG.1

ITEM	PART NUMBER	QTY	TRANS CODE	DESCRIPTION	DESCRIZIONE
1	10517171	4	132R	LOCKWASHER 14,2x3,5	ROSETTA DI SICUREZZA 14,2x3,5
2	10517271	4	132R	LOCKWASHER 16,2x4	ROSETTA DI SICUREZZA 16,2x4
3	10517471	8	132R	LOCKWASHER 20,2x4,5	ROSETTA DI SICUREZZA 20,2x4,5
4	10520221	4	131R	WASHER 16,4x28	ROSETTA 16,4x28
5	10571771	2	132R	LOCKWASHER 8,1x2	ROSETTA DI SICUREZZA 8,1x2
6	10571871	4	132R	LOCKWASHER 10,2x2,2	ROSETTA DI SICUREZZA 10,2x2,2
7	10571971	12	132R	LOCKWASHER 12,2x2,5	ROSETTA DI SICUREZZA 12,2x2,5
8	11103031	4	40V	SCREW 10x1,5x18	VITE 10x1,5x18
9	11112431	4	40V	SCREW 12x1,75x30	VITE 12x1,75x30
10	11112831	8	40V	SCREW 12x1,75x40	VITE 12x1,75x40
11	11113231	6	40V	SCREW 12x1,75x50	VITE 12x1,75x50
12	11118731	4	40V	SCREW 16x2x40	VITE 16x2x40
13	12644320	4	131R	WASHER 10,2x35	ROSETTA 10,2x35
14	12646721	2	131R	WASHER 8,15x20	ROSETTA 8,15x20
15	12646921	4	131R	WASHER 12,2x28	ROSETTA 12,2x28
16	15977931	4	40V	SCREW 14x1,5x90	VITE 14x1,5x90
17	15989331	8	40V	SCREW 20x1,5x110	VITE 20x1,5x110
18	16043431	2	40V	SCREW 8x1,25x20	VITE 8x1,25x20
19	79016720	4	95B	BUSHING C1163	BOCCOLA C1163
	79048203	4	95B	BUSHING D1163	BOCCOLA D1163
20	79026936	1	180T	CROSS BEAM - REAR	TRAVERSA - POSTERIORE
21	79026974		198S	SHIM	SPESSORE
22	79027289	1	300S	SUPPORT	SUPPORTO
	79027296	1	300S	SUPPORT	SUPPORTO
24	79027338	6	131R	WASHER	ROSETTA
25	79033501	1	31P	FENDER - REAR RIGHT ASSEMBLY C1163	PARAFANGO - POSTERIORE DESTRO COMPLETO C1163

MUDGUARDS AND FOOTBOARDS - PARAFANGHI E PEDANE - AILES ET MARCHEPIEDS - KOTFLUEGEL
UND TRITTBRETTEN - GUARDABARROS Y PISO

2

L3.04

1

N.T.R. 152 - 28.11.1986
604.01.081.02

L7

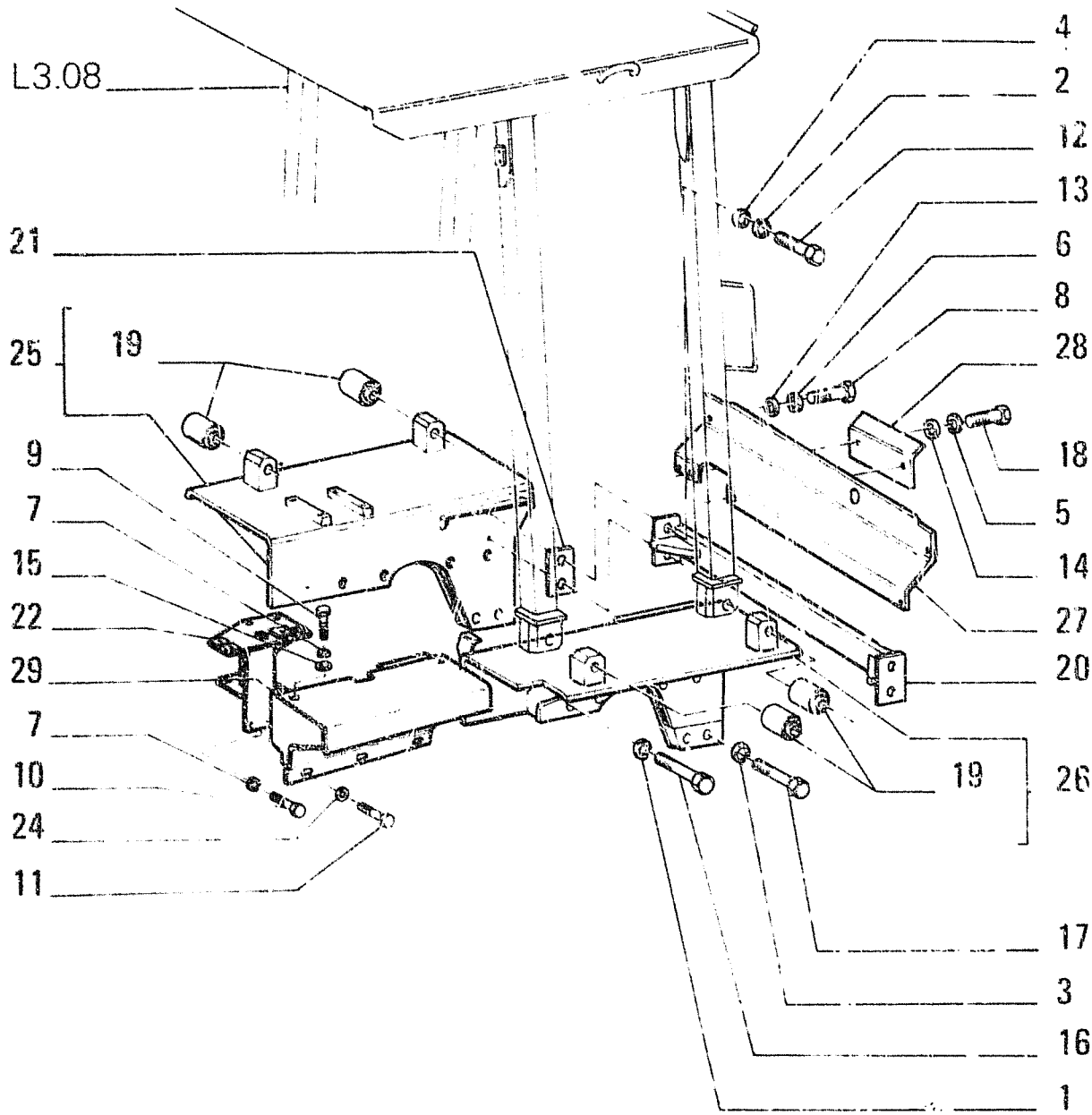

FIATALLIS FD7

ITEM	PART NUMBER	QTY	TRANS CODE	DESCRIPTION	DESCRIZIONE
25	79048258	1	31P	FENDER - REAR RIGHT ASSEMBLY D1163	PARAFANGO - POSTERIORE DESTRO COMPLETO D1163
26	79033502	1	31P	FENDER - REAR LEFT ASSEMBLY C1163	PARAFANGO - POSTERIORE SINISTRO COMPLETO C1163
	79048259	1	31P	FENDER - REAR LEFT ASSEMBLY D1163	PARAFANGO - POSTERIORE SINISTRO COMPLETO D1163
27	79034524	1	70R	GUARD - REAR	RIPARO - POSTERIORE
28	79034526	1	265C	COVER	COPERCHIO
29	79045870	1	31P	FENDER - FRONT RIGHT	PARAFANGO - ANTERIORE DESTRO
	79045873	1	31P	FENDER - FRONT LEFT	PARAFANGO - ANTERIORE SINISTRO

MUDGUARDS AND FOOTBOARDS - PARAFANGHI E PEDANE - AILES ET MARCHEPIEDS - KOTFLUEGEL
UND TRITTBRETTEN - GUARDABARROS Y PISO

2

L3.04

1

N.T.R. 152 - 28.11.1986
604.01.081.02

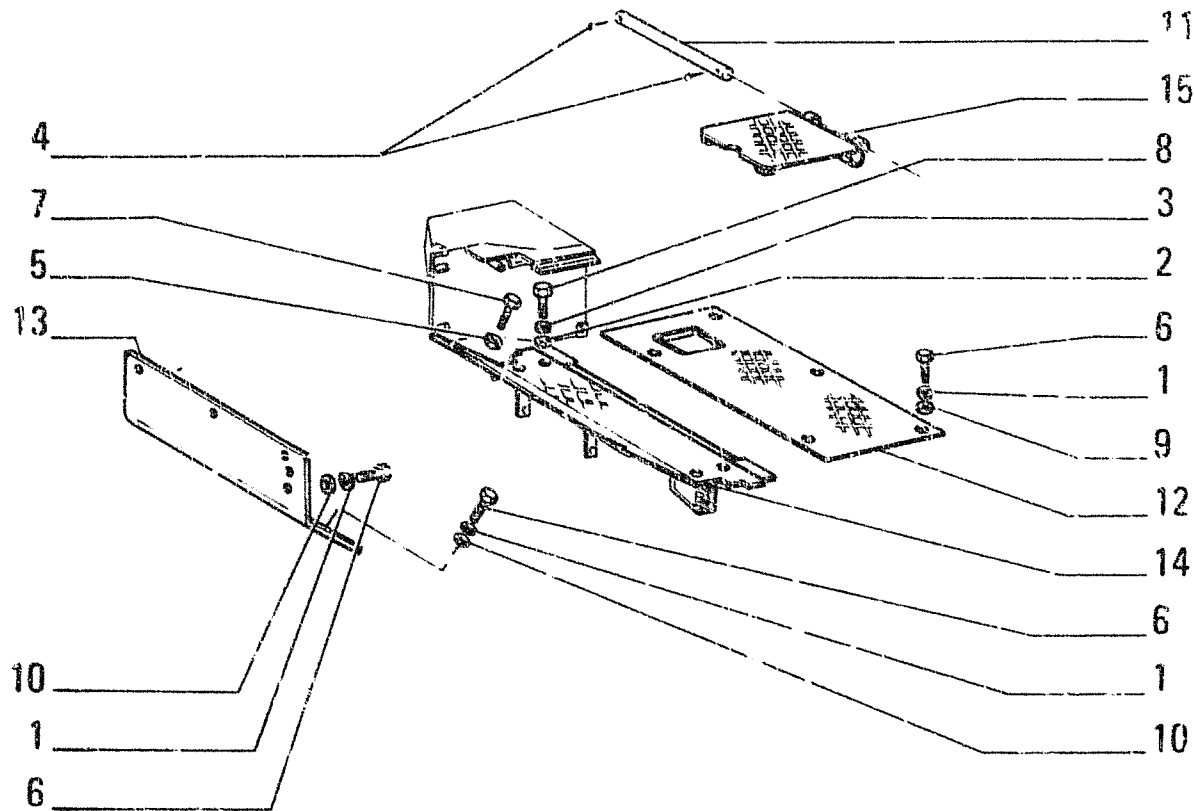

ITEM	PART NUMBER	QTY	TRANS CODE	DESCRIPTION	DESCRIZIONE
1	10516871	11	132R	LOCKWASHER 10x2,5	ROSETTA DI SICUREZZA 10x2,5
2	10517071	4	132R	LOCKWASHER 12,2x3,1	ROSETTA DI SICUREZZA 12,2x3,1
3	10520020	4	131R	WASHER 12,2x22	ROSETTA 12,2x22
4	10734201	2	270C	COTTER PIN 1,7x18,5	COPIGLIA 1,7x18,5
5	10788721	1	10D	NUT 10x1,5x6	DADO 10x1,5x6
6	11106231	11	40V	SCREW 10x1,5x25	VITE 10x1,5x25
7	11106431	1	40V	SCREW 10x1,5x30 C1509	VITE 10x1,5x30 C1509
	15215031	1	40V	SCREW D2908	VITE D2908
	16160131	1	40V	SCREW D1509	VITE D1509
		1	40V	SCREW C2908	VITE C2908
8	11112631	4	40V	SCREW 12x1,75x35	VITE 12x1,75x35
9	12646820	5	131R	WASHER 10,2x25	ROSETTA 10,2x25
10	12646821	6	131R	WASHER 10,2x25	ROSETTA 10,2x25
11	79010160	1	80P	PIN	PERNO
12	79026918	1	64P	FLOOR PLATE - REAR	PEDANA - POSTERIORE
13	79027337	1	70R	GUARD	RIPARO
14	79035945	1	64P	FLOOR PLATE	PEDANA
15	79040505	1	205S	DOOR	SPORTELLO

MUDGUARDS AND FOOTBOARDS - PARAFANGHI E PEDANE - AILES ET MARCHEPIEDS - KOTFLUEGEL UND TRITTBRETTNER - GUARDABARROS Y PISO

L9

2	L3.04	2
N.T.R. 191 - 20.02.1990		
604.01.081.04		

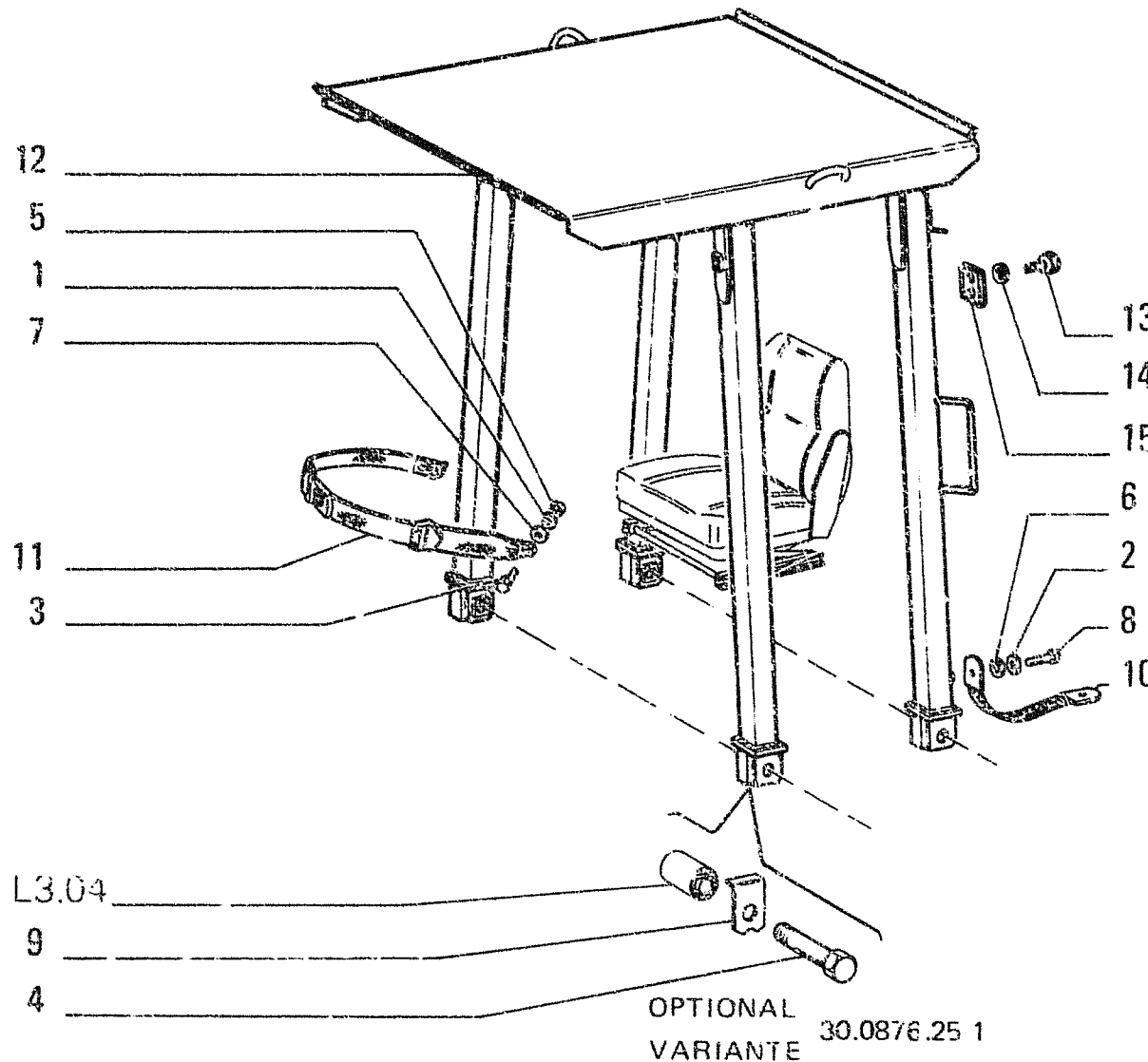

ITEM	PART NUMBER	QTY	TRANS CODE	DESCRIPTION	DESCRIZIONE
1	10516871	2	132R	LOCKWASHER 10x2,5	ROSETTA DI SICUREZZA 10x2,5
2	10511871	2	132R	LOCKWASHER 10,2x2,2	ROSETTA DI SICUREZZA 10,2x2,2
3	11106431	2	40V	SCREW 10x1,5x30	VITE 10x1,5x30
4	11125931	4	40V	SCREW 20x2,5x110	VITE 20x2,5x110
5	11701721	2	10D	NUT 10x1,5x8	DADO 10x1,5x8
6	12638601	2	131R	WASHER 10,2x18	ROSETTA 10,2x18
7	12648821	2	131R	WASHER 10,2x25	ROSETTA 10,2x25
8	15970331	2	40V	SCREW 10x1,25x16	VITE 10x1,25x16
9	76014842	4	113P	LOCKPLATE D2874	PIASTRINA DI SICUREZZA D2874
	79016327	4	113P	LOCKPLATE G2874	PIASTRINA DI SICUREZZA G2874
10	79017173	1	166T	GROUND BRAID	TRECCIA DI MASSA
11	79025920	1	182C	SAFETY BELT	CINTURA DI SICUREZZA
12	79033412	1	72I	FRAME	INTELLAIATURA
13	15995631	8	40V	SCREW 18x1,5x120 D1161	VITE 18x1,5x120 D1161
14	79005239	8	131R	WASHER D1161	ROSETTA D1161
15	79048245		198S	SHIM D1161	SPessore D1161

ROPS CANOPY - STRUTTURA DI PROTEZIONE ROPS - STRUCTURE DE PROTECTION ROPS - ROPS-²
 DACH - TOLDO ROPS

L3.08

N.T.R. 191 - 20.02 1990
 604.01.081.04

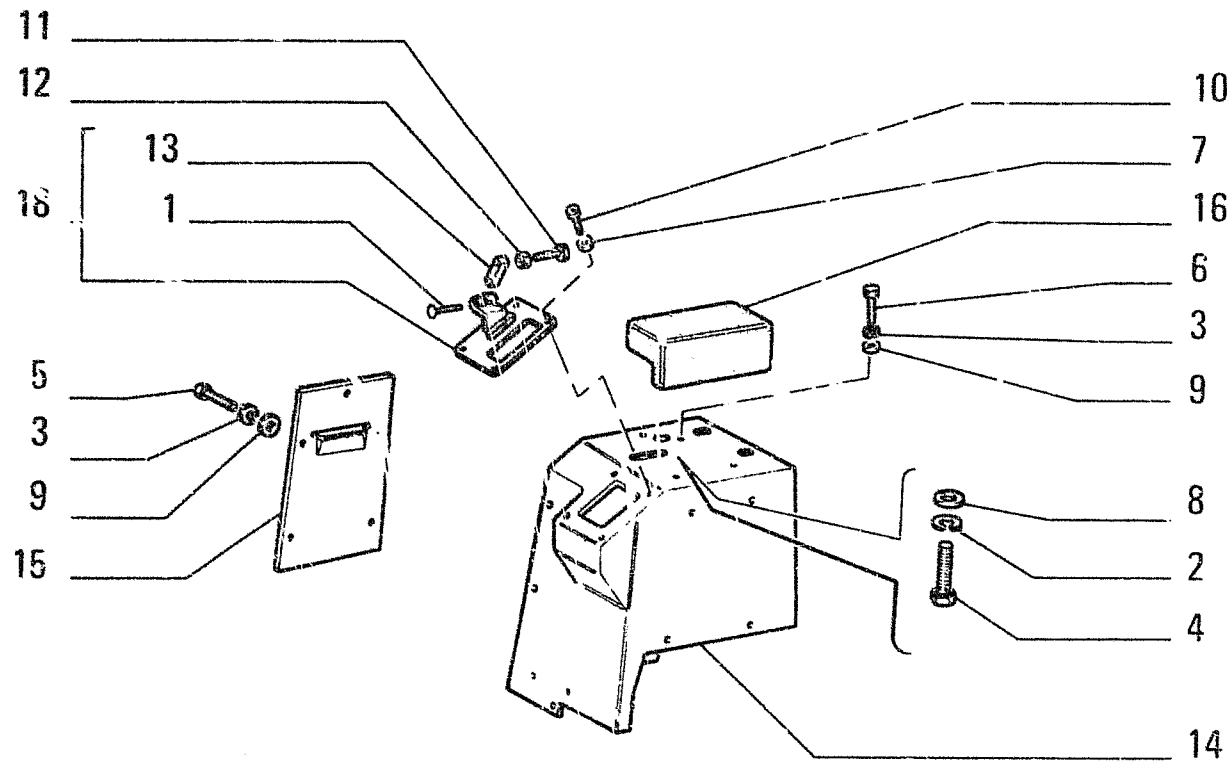

ITEM	PART NUMBER	QTY	TRANS CODE	DESCRIPTION	DESCRIZIONE
1	10253900	1	55R	RIVET 6x55	RIPATTINO 6x55
2	10516471	8	132R	LOCKWASHER 6,1x1,8	ROSETTA DI SICUREZZA 6,1x1,8
3	10516871	9	132R	LOCKWASHER 10x2,5	ROSETTA DI SICUREZZA 10x2,5
4	10902121	8	40V	SCREW 6x1x14	VITE 6x1x14
5	11106031	5	40V	SCREW 10x1,5x20	VITE 10x1,5x20
6	11106231	4	40V	SCREW 10x1,5x25	VITE 10x1,5x25
7	12598371	4	132R	LOCKWASHER 8,1x15,8	ROSETTA DI SICUREZZA 8,1x15,8
8	12644421	8	131R	WASHER 6,15x15	ROSETTA 6,15x15
9	12646821	9	131R	WASHER 10,2x25	ROSETTA 10,2x25
10	13279217	4	40V	SCREW 8x1,25x16	VITE 8x1,25x16
11	16043631	1	40V	SCREW 8x1,25x25	VITE 8x1,25x25
12	16100821	1	10D	NUT 8x1,25x6,5	DADO 8x1,25x6,5
13	79025574	1	45L	LEVER	LEVA
14	79027364	1	115M	PILLAR - RIGHT	MONTANTE - DESTRO
15	79027405	1	205S	DOOR - RIGHT	SPORTELLINO - DESTRO
16	79027559	2	124B	ARMREST	BRACCIOLO SEDILE
18	79031744	1	136S	SPROCKET SECTOR - ASSEMBLY	SETTORE RUOTA MOTRICE - COMPLETO

SEAT PANELS - RIPARI SEDILE - PROTECTIONS DE SIEGE - SITZSCHUETZER -
 PROTECCIONES DEL ASIENTO

L3.10

1

N.T.R. 158 - 13.03.1987
 604.01.081.03

L11

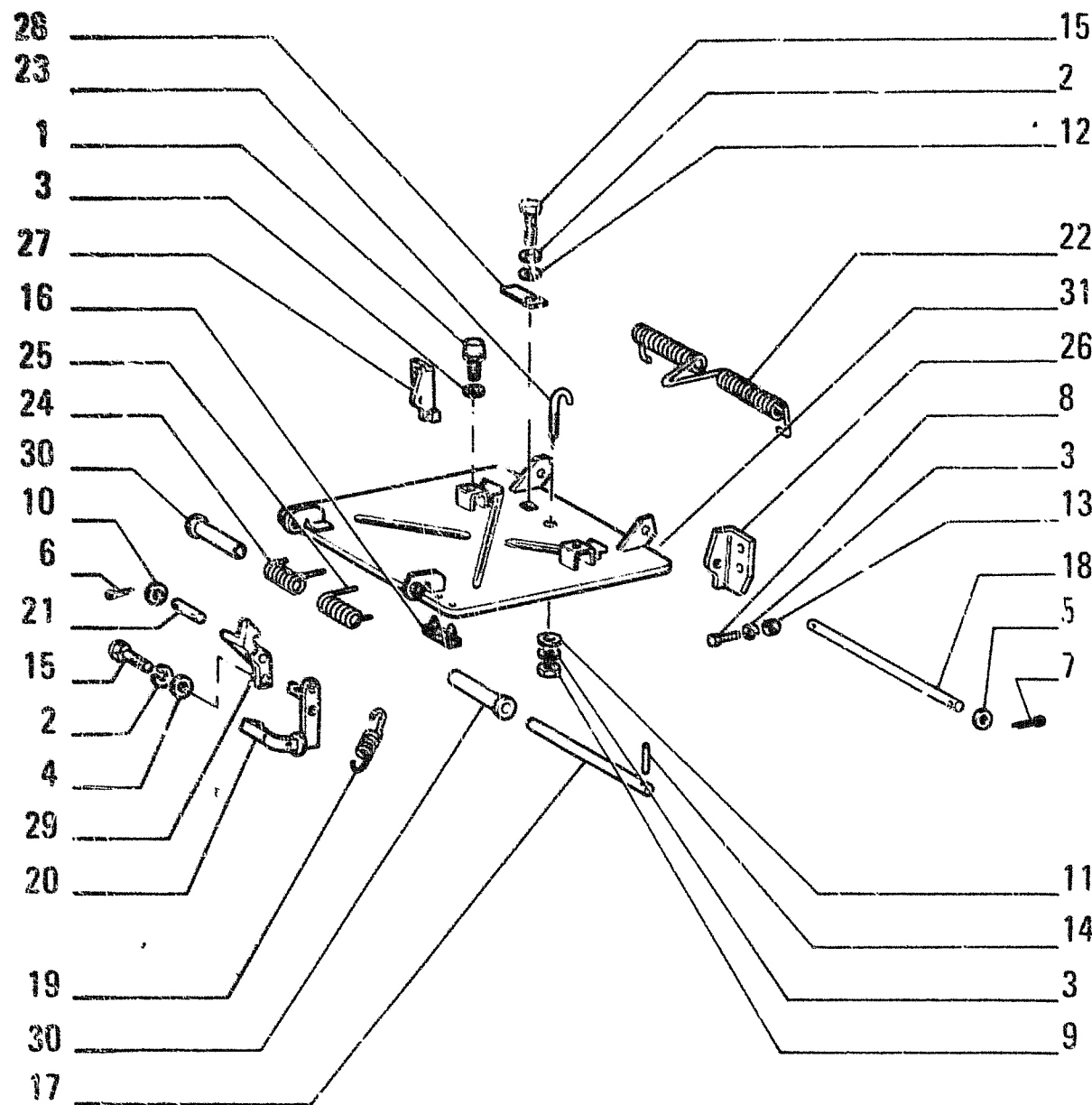

FIATALLIS FD7

ITEM	PART NUMBER	QTY	TRANS CODE	DESCRIPTION	DESCRIZIONE
1	591420	2	60T	BLOCK - IN ALTERNATIVE	TASSELLO - IN ALTERNATIVA
	79037282	2	60T	BLOCK - IN ALTERNATIVE D3335	TASSELLO - IN ALTERNATIVA D3335
2	10516671	2	132R	LOCKWASHER 8,1x2,2	ROSETTÀ DI SICUREZZA 8,1x2,2
3	10516871	7	132R	LOCKWASHER 10x2,5	ROSETTA DI SICUREZZA 10x2,5
4	10519621	1	131R	WASHER 8,45x17	ROSETTA 8,45x17
5	10520221	2	131R	WASHER 16,4x28	ROSETTA 16,4x28
6	10734201	2	270C	COTTER PIN 1,7x18,5	COPIGLIA 1,7x18,5
7	10797101	2	270C	COTTER PIN 4,4x34	COPIGLIA 4,4x34
8	11106431	4	40V	SCREW 10x1,5x30	VITE 10x1,5x30
9	11701721	1	10D	NUT 10x1,5x8	DADO 10x1,5x8
10	12638621	2	131R	WASHER 10,2x18	ROSETTA 10,2x18
11	12644321	1	131R	WASHER 10,2x35	ROSETTA 10,2x35
12	12646721	1	131R	WASHER 8,15x20	ROSETTA 8,15x20
13	12646821	4	131R	WASHER 10,2x25	ROSETTA 10,2x25
14	14164770	1	200S	PIN 4,4x40	SPINA 4,4x40
15	16043631	2	40V	SCREW 8x1,25x25	VITE 8x1,25x25
16	79010401	2	60T	BLOCK	TASSELLO
17	79025453	1	16A	SHAFT	ALBERO
18	79025458	1	16A	SHAFT	ALBERO
19	79025470	1	100M	SPRING	MOLLA
20	79025508	1	60P	PEDAL	PEDALE
21	79025548	1	80P	PIN	PERNO
22	79026148	1	100M	SPRING	MOLLA
23	79026149	1	30G	HOOK	GANCIO
24	79026153	1	100M	SPRING - LEFT	MOLLA - SINISTRO
25	79026154	1	100M	SPRING - RIGHT	MOLLA - DESTRO

SEAT PANELS - RIPARI SEDILE - PROTECTIONS DE SIEGE - SITZSCHUETZER -
 PROTECCIONES DEL ASIENTO

L3.10 2
 N.T.F. 700 - 15.10.1990
 604.01.081.05

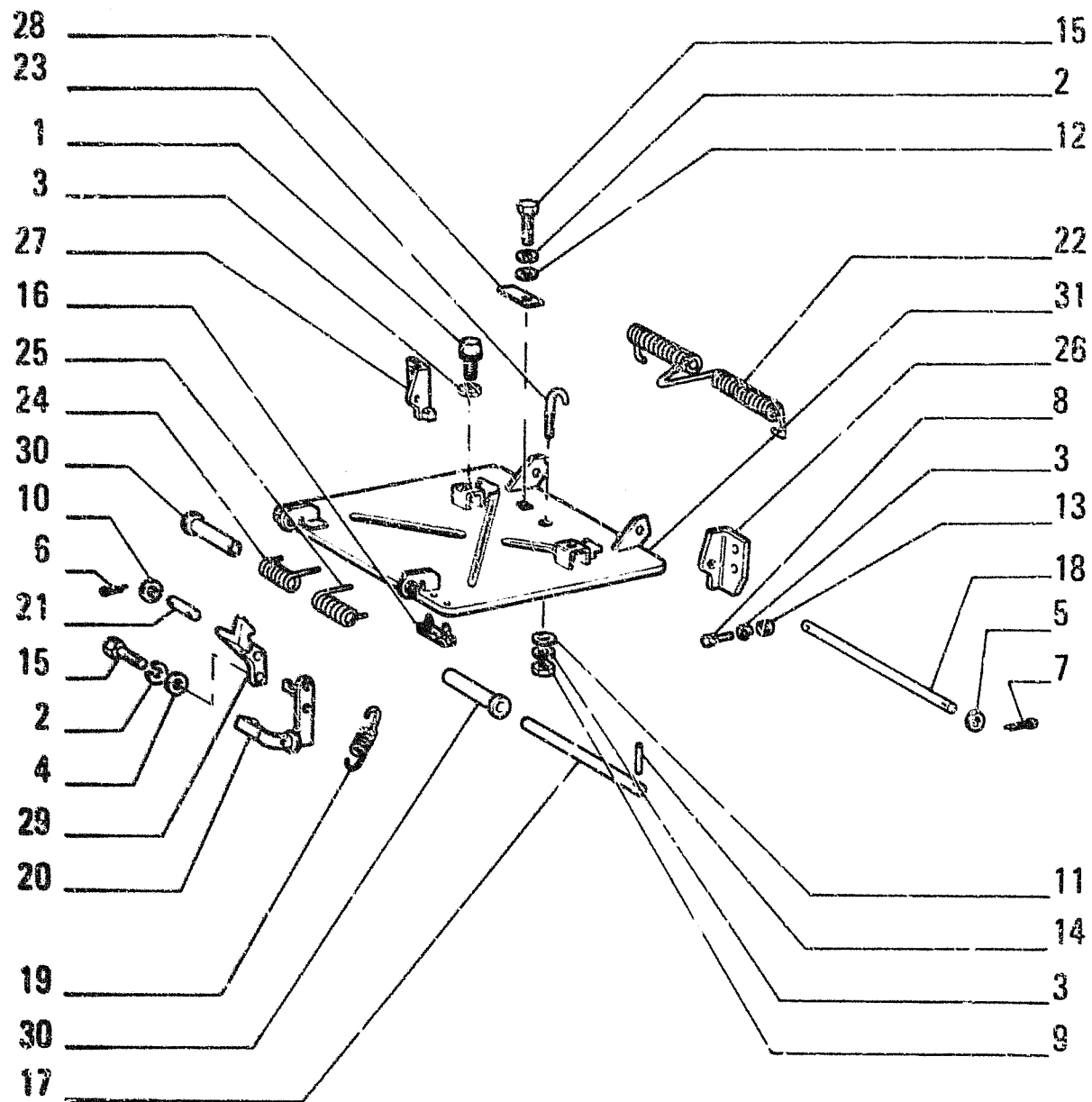

FIATALLIS FD7

L3.10 TAV. 2 PAG.2

ITEM	PART NUMBER	QTY	TRANS CODE	DESCRIPTION	DESCRIZIONE
26	79027057	1	225S	BRACKET - LEFT	STAFFA - SINISTRO
27	79027058	1	225S	BRACKET - RIGHT	STAFFA - DESTRO
28	79027428	1	105P	PLATE	PIASTRA
29	79028272	1	30G	HOOK - FRONT	GANCIO - ANTERIORE
30	79028347	2	75D	SPACER	DISTANZIALE
31	79036971	1	300S	SUPPORT	SUPPORTO

SEAT PANELS - RIPARI SEDILE - PROTECTIONS DE SIEGE - SITZSCHUETZER -
 PROTECCIONES DEL ASIENTO

L3.10

2

N.T.R. 200 - 15.10.1990
 604.01.081.05

L13

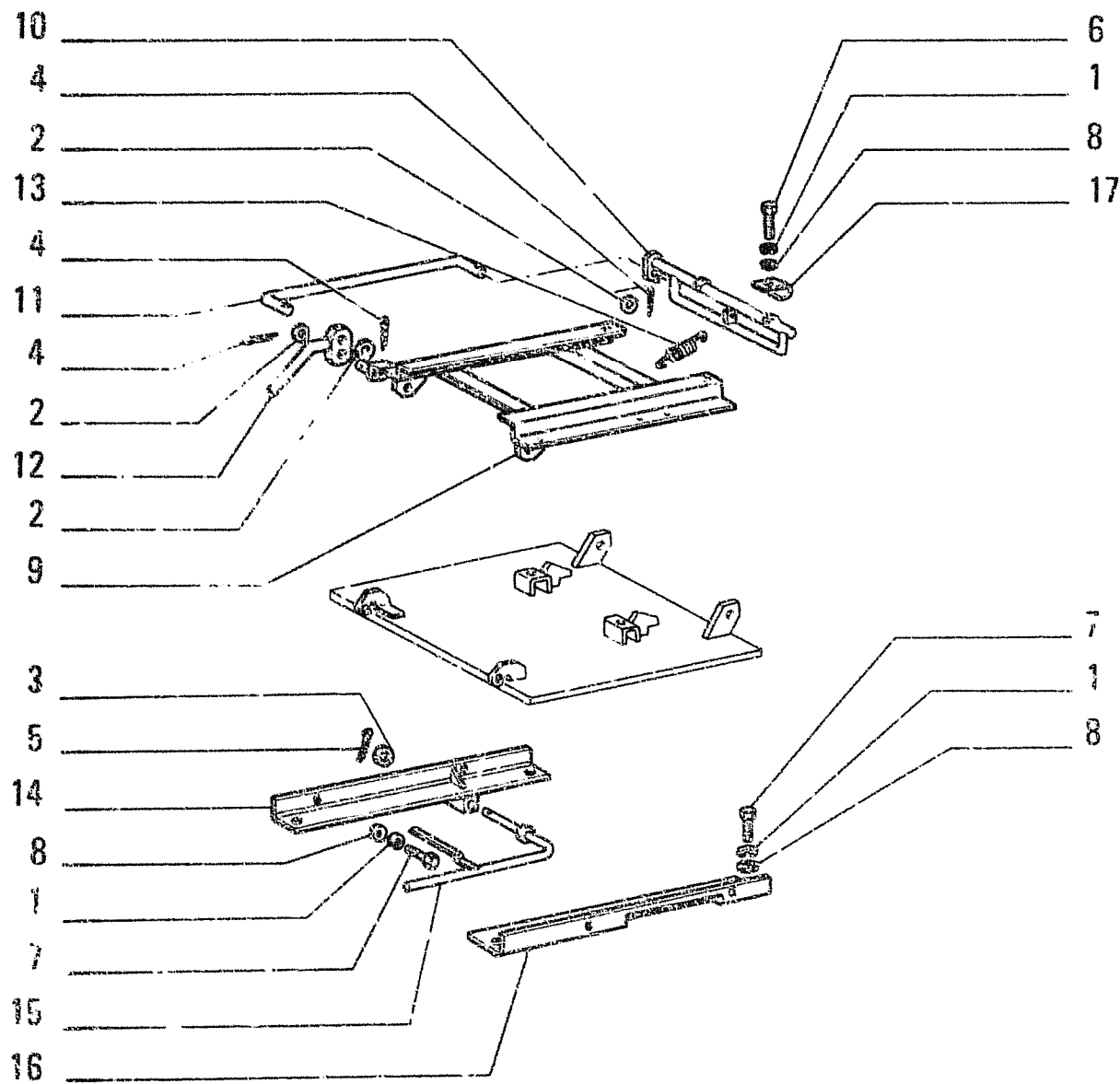

FIATALLIS FD7

ITEM	PART NUMBER	QTY	TRANS CODE	DESCRIPTION	DESCRIZIONE
1	10516871	6	132P	LOCKWASHER 10x2,5	ROSETTA DI SICUREZZA 10x2,5
2	10519621	3	131R	WASHER 8,45x17	ROSETTA 8,45x17
3	10520021	1	131R	WASHER 12,2x22	ROSETTA 12,2x22
4	10796301	3	270C	COTTER PIN 2,7x21,6	COPIGLIA 2,7x21,6
5	10796401	1	270C	COTTER PIN 2,7x27,6	COPIGLIA 2,7x27,6
6	11103031	2	40V	SCREW 10x1,5x18	VITE 10x1,5x18
7	11106031	4	40V	SCREW 10x1,5x20	VITE 10x1,5x20
8	12646821	6	131R	WASHER 10,2x25	ROSETTA 10,2x25
9	79025399	1	300C	BODY	CORPO
10	79025462	1	30G	HOOK - REAR	GANCIO - POSTERIORE
11	79025468	1	142T	TIEROD	TIRANTE
12	79025469	1	45L	LEVER	LEVA
13	79025470	1	100M	SPRING	MOLLA
14	79027055	1	60A	ANGLE - INNER	ANGOLARE - INTERNO
15	79027056	1	238P	PUSH ROD	PUNTALE
16	79034091	1	60A	ANGLE - INNER	ANGOLARE - INTERNO
17	79035168	2	140C	HINGE	CERNIERA

SEAT PANELS - RIPARI SEDILE
 PROTECCIONES DEL ASIENTO

PROTECTIONS DE SIEGE - SITZSCHUETZER

L3.10

3

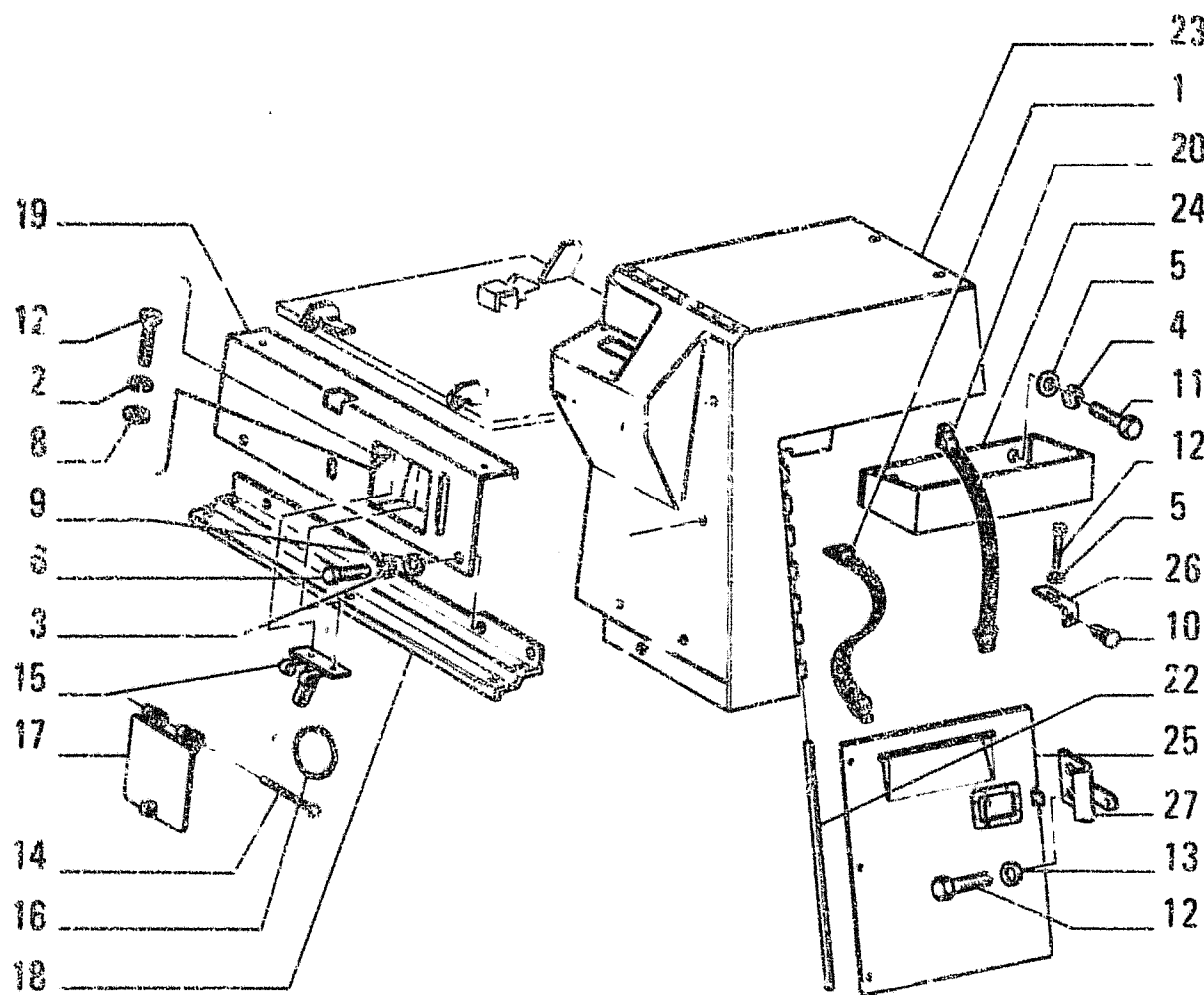

ITEM	PART NUMBER	QTY	TRANS CODE	DESCRIPTION	DESCRIZIONE
1	4293094	1	172C	SECURING STRAP	CINGHIA DI FISSAGGIO
2	10516671	4	132R	LOCKWASHER 8,1x2,2	ROSETTA DI SICUREZZA 8,1x2,2
3	10516877	4	133R	LOCKWASHER 10x2,5	ROSETTA DI SICUREZZA 10x2,5
4	10518621	2	131R	WASHER 8,45x17	ROSETTA 8,45x17
5	10571771	3	132R	LOCKWASHER 8,1x2	ROSETTA DI SICUREZZA 8,1x2
6	11106031	2	40V	SCREW 10x1,5x20	VITE 10x1,5x20
7	11106231	2	40V	SCREW 10x1,5x25	VITE 10x1,5x25
8	12642021	4	131R	WASHER 8,15x25	ROSETTA 8,15x25
9	12646821	4	131R	WASHER 10,2x25	ROSETTA 10,2x25
10	14567080	1	120B	BUTTON 8,5x14	BOTTONE 8,5x14
11	16043231	2	40V	SCREW 8x1,25x16	VITE 8x1,25x16
12	16043431	6	40V	SCREW 8x1,25x20	VITE 8x1,25x20
13	79005244	2	131R	WASHER	ROSETTA
14	79025535	1	80P	PIN	PERNO
15	79025536	1	140V	HINGE	CERNIERA
16	79025540	1	100M	SPRING	MOLLA
17	79025541	1	205S	DOOR	SPORTELLO
18	79027392	1	180T	CROSS BEAM	TRAVERSA
19	79027424	1	140P	PLANK - FRONT	PLANCIA - ANTERIORE
20	79030150	1	172C	SECURING STRAP	CINGHIA DI FISSAGGIO
22	79033896	1	80P	PIN	PERNO
23	79033899	1	115M	PILLAR - LEFT ASSEMBLY	MONTANTE - SINISTRO COMPLETO
24	79033959	1	87C	TOOL BOX	CASSETTA ATTREZZI
25	79034003	1	205S	DOOR - LEFT	SPORTELLO - SINISTRO
26	79035257	1	225S	BRACKET	STAFFA
27	79035414	1	225S	BRACKET - LEFT	STAFFA - SINISTRO

SEAT PANELS - RIPARI SEDILE - PROTECTIONS DE SIEGE - SITZSCHUETZER - PROTECCIONES DEL ASIENTO

L3.10

4

N.T.R. 158 - 13.03.1987

604.01.081.03

L15

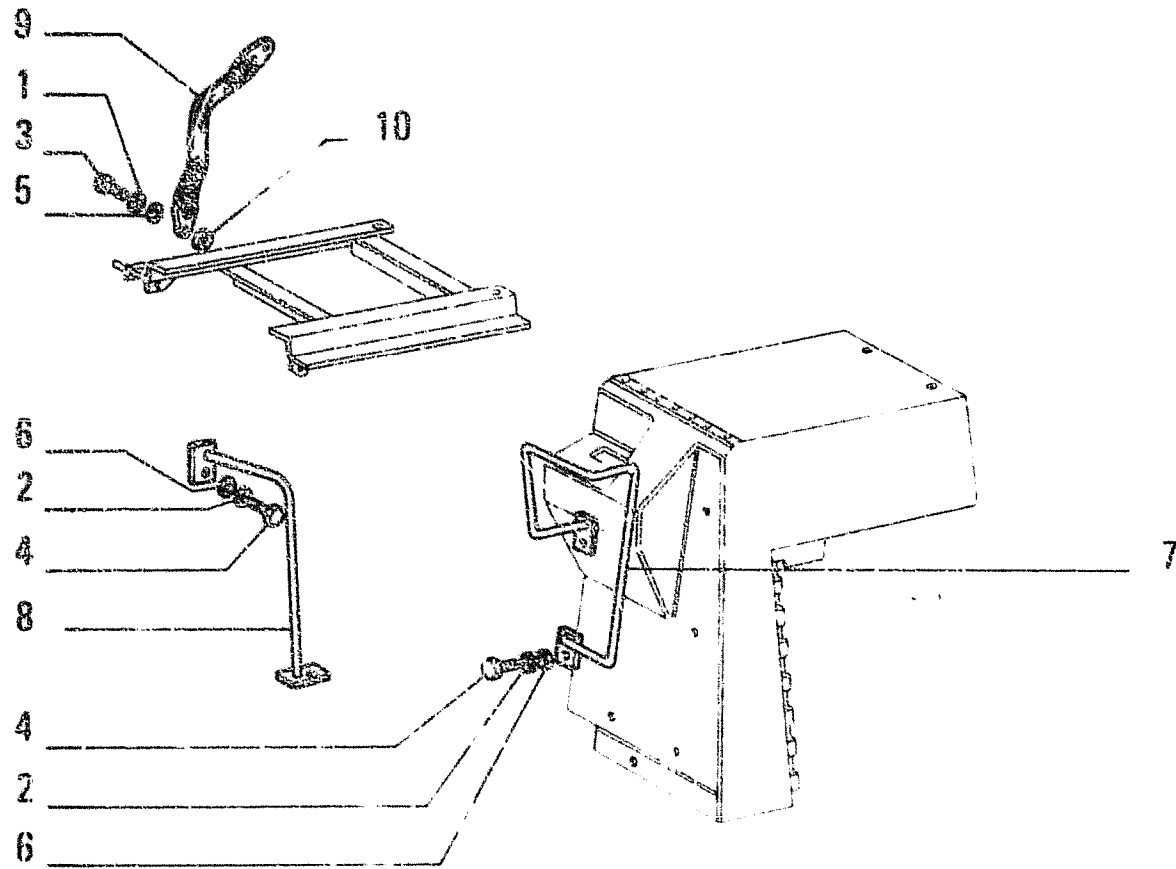

ITEM	PART NUMBER	QTY	TRANS CODE	DESCRIPTION	DESCRIZIONE
1	10516871	2	132R	LOCKWASHER 10x2,5	ROSETTA DI SICUREZZA 10x2,5
2	10517071	8	132R	LOCKWASHER 12,2x3,1	ROSETTA DI SICUREZZA 12,2x3,1
3	11106431	2	40V	SCREW 10x1,5x30	VITE 10x1,5x30
4	11112231	8	40V	SCREW 12x1,75x22	VITE 12x1,75x22
5	12646821	2	131R	WASHER 10,2x25	ROSETTA 10,2x25
6	12646921	8	131R	WASHER 12,2x28	ROSETTA 12,2x28
7	79025239	1	20M	HANDLE - REAR RIGHT	MANIGLIA - POSTERIORE DESTRO
	79025241	1	20M	HANDLE - REAR LEFT	MANIGLIA - POSTERIORE SINISTRO
8	79027408	1	20M	HANDLE - FRONT RIGHT	MANIGLIA - ANTERIORE DESTRO
	79027410	1	20M	HANDLE - FRONT LEFT	MANIGLIA - ANTERIORE SINISTRO
9	79035075	2	142T	TIEROD	TIRANTE
10	79014057	2	73D	SPACER D2947	DISTANZIALE D2947

SEAT PANELS - RIPARI SEDILE - PROTECTIONS DE SIEGE - SITZSCHUETZER -
 PROTECCIONES DEL ASIENTO

L3.10

5

N.T.R. 191 - 20.02.1990

604.01.081.04

L16

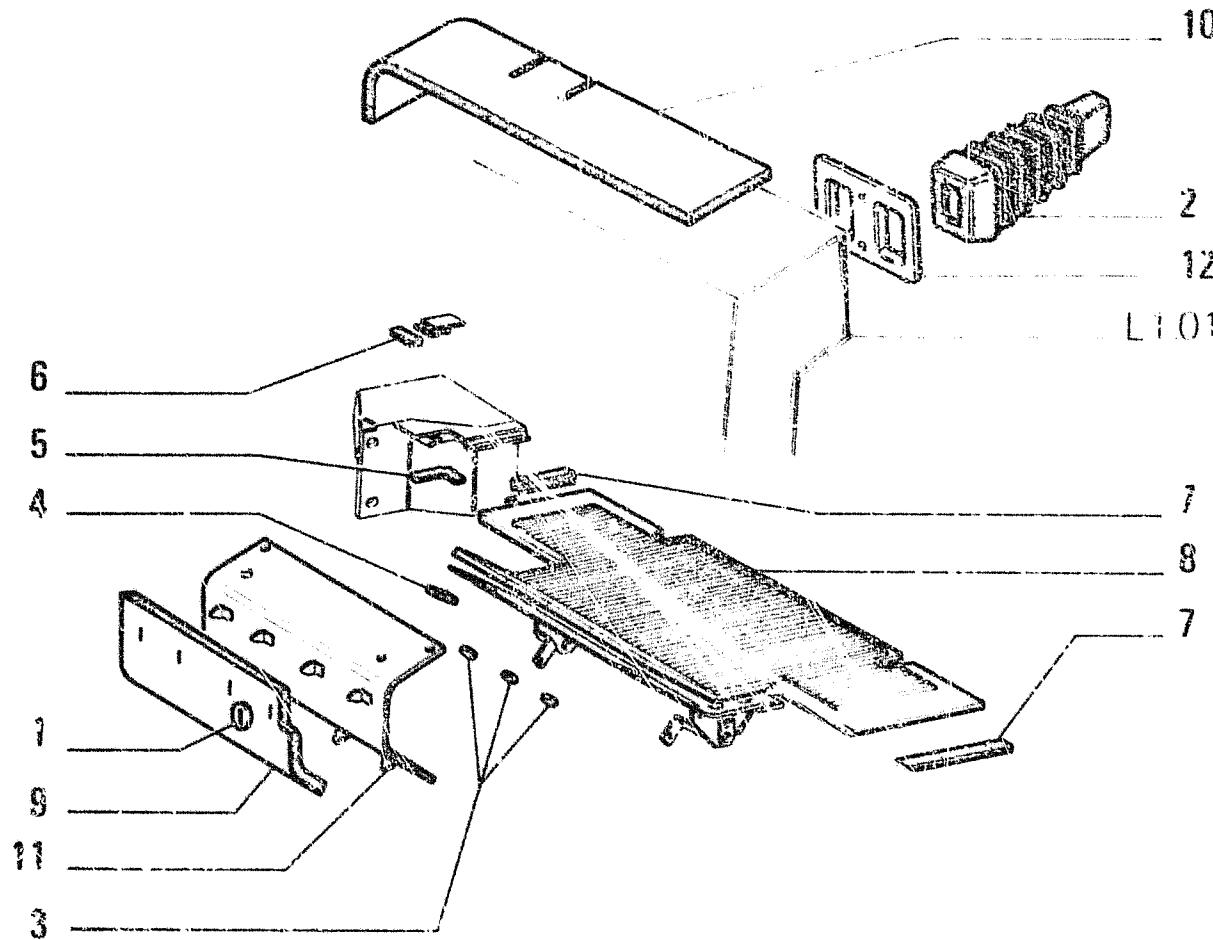

ITEM	PART NUMBER	QTY	TRANS CODE	DESCRIPTION	DESCRIZIONE
1	79002868	8	131R	WASHER	ROSETTA
2	79030670	2	330C	RADIATOR GUARD	CUFFIA RADIATORE
3	79035791	3	25P	PANEL	PANNELLO
4	79035792	2	25P	PANEL	PANNELLO
5	79037635	1	25P	PANEL	PANNELLO
6	79037636	1	25P	PANEL	PANNELLO
7	79039312	2	25P	PANEL	PANNELLO
8	79039313	1	25P	PANEL	PANNELLO
9	79039314	1	25P	PANEL	PANNELLO
10	79039315	1	25P	PANEL	PANNELLO
11	79039317	1	70R	GUARD	RIPARO
12	79043015	1	165P	PLATE	PIASTRA

OPTIONAL
VARIANTE 30.0020.16.1

SEAT PANELS - RIPARI SEDILE - PROTECTIONS DE SIEGE - SITZSCHUETZER - PROTECCIONES DEL ASIENTO

L3.10/1

1

L17

DESIGNAZIONE BASE	BASE DESIGNATION	DESIGNATION BASES	BEZUGSBEZEICHNUNGEN	DESIGNACIONES BASE
159C	CILINDRO FRENO	BARREL CYLINDER	CYLINDRE DE FREIN	CILINDRO DE FRENO
159G	GUARNIZIONE LIQUIDA	PACKET LIQUID	PRODUIT LIQUID POUR ETANCHE	SELLADOR
159R	RUOTA MOTRICE	GEAR WHEEL	BARBOTIN	RUEDA MOTRIZ
159S	SILENZIATORE SUPPLEMENTARE	AUXILIARY SILENCER	SILENCIEUX SUPPLEMENTAIRE	SILENCIADOR SUPLEMENTARIO
159S				
159C	GRANUCOLA	LEAD HUT	ESCHOU EN GRANULE	TUERCA
160G	GRANULATO FERROSO	FERROUS GRANULATE	GRANULE FERRUGINEUX	GRANULADO DE HIERRO
160R	RUOTA	WHEEL	ROUE	RUEDA
160S	SILENZIATORE	MUFFLER	SILENCIEUX	SILENCIADOR
160T	TRASMETTITORE	SENDING UNIT	TRANSMETTEUR	CONTACTOR
160S	ATTREZZO SCRAPER	SCRAPER IMPLEMENT	EQUIPEMENT RACLOIR	
161C	CILINDRO, CLASSE	CYLINDER, CLASS...	CYLINDER, CLASSE...	CILINDRO, CLASSE...
161G	GRASSO	GREASE	GRASSE	
161P	POMPA IDRAULICA	HYDRAULIC PUMP	POMPE HYDRAULIQUE	BOMBA HIDRAULICA
161R	RUOTA LIBERA	FREE WHEEL	ROUE LIBRE	RUEDA LIBRE
161S	SINCRONIZZATORE	SYNCHRONIZER	SYNCHRONISEUR	SINCRONIZADOR
161T	CILINDRO PNEUMATICO	AIR CYLINDER	CYLINDRE PNEUMATIQ	CILINDRO PNEUMATICO
162C				
162C	CILINDRETTO	BARREL	CYLINDRE	CILINDRO
163R	RUOTA MOTRICE	SPROCKET	BARBOTIN MOTEUR	RUEDA MOTRIZ
164C	CILINDRO	CYLINDER	CYLINDRE	CILINDRO
164P	POMPA SERVOCOMANDO	SERVO CONTROL PUMP	POMPE DE SERVO-COMMANDE	BOMBA DE SERVO-COMANDO
164P				
164S	SMORZATORE	DAMPER	AMORTISSEUR	AMORTIZADOR
164S				
165P	PONTE	AXLE	PONT	PUENTE
165R	RUTTORE	BREAKER	RUPTEUR	RUPTOR
165C	FRANCO	ARTICULATION	ARTICULATION	ARTICULACION
165T	TRASMISSIONE FLESSIBILE	FLEXIBLE SHAFT	TRANSMISSION FLEXIBLE	ANJOL FLEXIBLE
166C	CILINDRO DI COMANDO GRANDE	WHEEL CYLINDER	CYLINDRE DE ROUE	CILINDRO DE FRENO
166R	RUOTA GUIDA	TRACK ROLLER	ROUE TENNEUSE	RUEDA DE GUIA
166S	SMORZETTO	BELLING	SOUFFLEUR	FUELLER
166T	TRECCIA DI MASSA	GROUND BRAID	TRESSE DE MASSE	TRENZA DE MASA
167C	CILINDRO DEL SERVOSTERZO	SERVO-ASSYSTD STEERING CYLINDER	CYLINDRE RECEPTEUR	CILINDRO DE SERVO-DIRECCION
167C				
167H	RADIATORE ACQUA	WATER RADIATOR	RADIATOR A L'EAU	RADIADOR DE AGUA
167S	SOLLEVATORE IDRAULICO	HYDRAULIC LIFTER	RELEVAGE HYDRAULIQUE	LEVANTE HIDRAULICO
167T	TRASPARENTE DELLO STOP	STOP LAMP LENS	TRANSPARENT DE FELIX STOP	TAPA TRANSLUCIDA DE LUCES DE FREN
167T				
168R	RADIATORE OLIO	OIL RADIATOR	RADIATOR A HUILE	RADIADOR DE ACEITE

DESIGNAZIONE BASE	BASIC DESIGNATION	DESIGNATIONS BASES	GRUNDBEZEICHNUNGEN	DEMONINACIONES BASE
1500	CHIAVE	KEY	SCHLUESSEL	LLAVE
1508	GUIDA DELLA VALVOLA	VALVE GUIDE	VENTILFUHRUNG	GUIA DE VALVULA
1509	POMELLO	KNOB	KNEDELGRIF	BOTON
1510	RUBINETTO	COCK	ROBINET	GRIFO
1515	SEGNA	TRADE MARK	SIGLE	SIGLA
1517	TIMER	TIMERS	TIMER	TIMER
1521	BARRA PORTAUTILI	TOOL BAR	BARRE PORTEOUTIL	BARRA
1522	BARRA	BAR	SARNE	BARRA
1526	CHIAVE A TUBO	PIPE WRENCH	CLE A TUBE	LLAVE DE TUBO
1528	GUIDA DELLA VALVOLA DI ASPIRAZIONE	INTAKE VALVE GUIDE	GUIDE DE SOUPAPE D'ADMISSION	GUIA DE LA VALVULA DE ADMISION
1529	POMELLO DI FISSAGGIO	RETAINING KNOB	POMMEAU DE FIXATION	POMO DE FIJACION
1529	1519			
1529	SEGNA TRATTORE	TYPE PLATE	TYPE	SIGLA TRACTOR
1528	SENNIA DA CAVA	CLAMNET BUCKET	GODET DE CARRIERE	CUCHARA PARA CANTERA
1528	GUIDA DELLA VALVOLA DI SCARICO	EXHAUST VALVE GUIDE	GUIDE DE SOUPAPE D'ECHAPPEMENT	GUIA DE LA VALVULA DE ESCAPE
1528	1527			
1529	POMPA ACQUA	WATER PUMP	POMPE A EAU	BOMBA DE AGUA
1529	SENNIA MORDENTE	CLAMNET BUCKET	GODET PRENEUSE	CUCHARA MORDIENTE
1528	GUIDA DI SCARICAMENTO	SLIDE GUIDE	COULISSE	GUIA DESLIZANTE
1529	POMPA OLIO	OIL PUMP	POMPE A HUILE	BOMBA DE ACEITE
1540	CHIAVE SERRATURA	LOCK KEY	CLE DE SERRURE	LLAVE DE CERRADURA
1549	POMPA ALIMENTAZIONE	FUEL PUMP	POMPE D'ALIMENTATION	BOMBA DE ALIMENTACION
1558	SENNIA DA ROTAZIONE	HOOK BUCKET	GODET DE ROCHE	CUCHARA PARA ROTAS
1556	GIUNTO RAPIDO	QUICK-CONNECTING COUPLING	ACCOUPLLEMENT RAPID	JUNTA RAPIDA
1559	POMPA	PUMP	POMPE	BOMBA
1559	ROLLINO	ROLLER	ROULEAU	RODILLO
1558	SILENTBLOC	SILENTBLOC	SILENTBLOC	SILENTBLOC
1559	SENNIA TRAPEZOIDALE	TRAPEZOIDAL BUCKET	GODET TRAPEZE	CUCHARA TRAPEZOIDAL
1558	INDICAZIONE	INDICATOR	INDICATEUR	INDICACION
1559	POMPA A MANO	HAND PUMP	POMPE A MAIN	BOMBA DE MANO
1570	SENNIA 4 IN 1	4-IN-1 BUCKET	GODET MULTIPLES	CUCHARA MULTI-USO
1570	GIUNTA ALBERO ROTANTE	LIP SEAL	GARNITURE D'ETANCHEITE	JUNTA
1579	POMPA ARIA	AIR PUMP	POMPE A AIR	BOMBA DE AIRE
1579	ROLLINO	ROLLER	GALET	RODILLO
1580	INVIATA	ENVELOPE	ENVELOPPE	ENVELOPE
1580	LINGUETTA A DISCO	WOODRUFF KEY	CLAVETTE	CHAVETA
1580	GIUNTA O-RING	O-RING	O-RING	GIUNTA O-RING
1589	POMPA INIEZIONE	INJECTION PUMP	POMPE D'INJECTION	BOMBA DE INYECCION
1591	TRASFORMATORE	TRANSFORMER	TRANSFORMATEUR	TRANSFORMADOR

DENOMINAZIONE BASE	BASIC DESIGNATION	DENOMINATIONS-BASES	GRUNDIRZEICHNUNGEN	DENOMINACIONES BASE
140C	CIRCONFERENZA	HINGE	CHARNIERE	BISAGRA
140G	GUAINA FLESSIBILE	SHEATH	GAINE	FUNDA
140P	PLANCHIA	PLANK	PLANCHE	TABLERO
140S	SFERA	BALL	BILLE	ESFERA
140Y	LAMA ABBATTIMENTO		LAME ABAJTAGE	
141B	MASTICE ADESIVO	PUTTY	MASTIC ADHESIF	ALMACIGA ADHESIVA
141D	PLANCHIA PORTASTRUMENTI	INSTRUMENT PANEL	TABLEAU DE BORD	CUADRO INSTRUMENTACION
141T	TIRANTE FILETTATO	THREADED TIEROD	TIRANT	PERNO
141Y	GUAINA	SHEATH	GAINE	FUNDA
142A	MOLLA A BALLESTRA	LEAF SPRING	ROSSORT A LAMES	MUELLE DE BALLESTA
142T	TIRANTE	TIEROD	TIRANT	TIRANTE
142Y	LAMA CAVACEPPI		LAME DESOUCHEUSE	
143M	MO'LOASSALE	LIVE AXLE	ESSIF, MOTEUR	EJE
143T	TIRANTE DI STERZO TRASVERSALE	TRACK ROD	BARRE D'ACCOUPLE- MENT	BARRA DE ACOPLA- MIENTO
143Y	LAMA SPIETRATRICE		LAME EPIERREUSE	
144M	MANIPOLATORE	MANIPULATOR	MANIPULATEUR	
144T	TIRANTE DI STERZO LONGITUDINA- LE	DRAG LINK	BARRE DE DIRECTION	BARRA DE DIRECCION
144Y	LAMA DECESPUGLIATRICE PER AD		LAME DEBROUSSAILLEUSE AD	
144Z	LAMA DECESPUGLIATRICE PER BD		LAME DEBROUSSAILLEUSE BD	
145B	RUSSOLA	GUIDE BUSHING	DOUILLE	CASQUILLO
145G	GUIDA	GUIDE	GUIDE	GUIA
145M	MADRIA CINGOLO	TRACK LINK	MAILLON	MALLA DE ORUGA
145P	PLANETARIO	SUN GEAR	PLANETAIRE	PINON PLANETARIO
145R	ROTORE	ROTOR	ROTOR	ROTOR
145S	SPIATTOIC	BREATHER	RENIFLARD	RESPIRADERO
146M	MODULO ANTERIORE	TOOL MODULE	MODULE ANTERIEUR	MODULO ANTERIOR
146R	RODULA INFERICA	BALL JOINT	RODULE	RODULA
146T	TIRANTE ELASTICO	ELASTIC TIEROD	TIRANT ELASTIQUE	VARILLA ELASTICA
147B	GUIDA DELLA MOLLA	SPRING GUIDE	GUIDE-RESSORT	GUIA DE RESORTE
147M	MODULO POSTERIORE	POWER MODULE	MODULE POSTERIEUR	MODULO POSTERIOR
147P	PNEUMATICO	TIRE	PNEU	NEUMATICO
147T	TORRETTA	TURRET	TOURELLE	TORRE
148P	POLVERIZZATORE	NOZZLE	PULVERISATEUR	PULVERIZADOR
148S	SI FORNISCONO SOLO LE PARTI	ONLY SEPARATE PARTS ARE SERVI- CED	ON LIVRE SEULEMENT SES PIECES	SOLO SE SUMINIS- TRAM LAS PIEZAS SUELTAS
148Z				
149S				
149T	RUBINETTO-VALVOLA	COCK VALVE	ROBINET	VALVULA
150B	BORSA	BAG	TROUSSE	BOLSA

L	BODY • CARROZZERIA • CARROSSERIE • AUFBAU • CARROCERIA
M	DRIVER S SEAT • SEDILE CONDUTTORE • SIEGE DE CONDUCTEUR • FAHRERSITZ • BUTACA DE CONDUCTOR.

M1

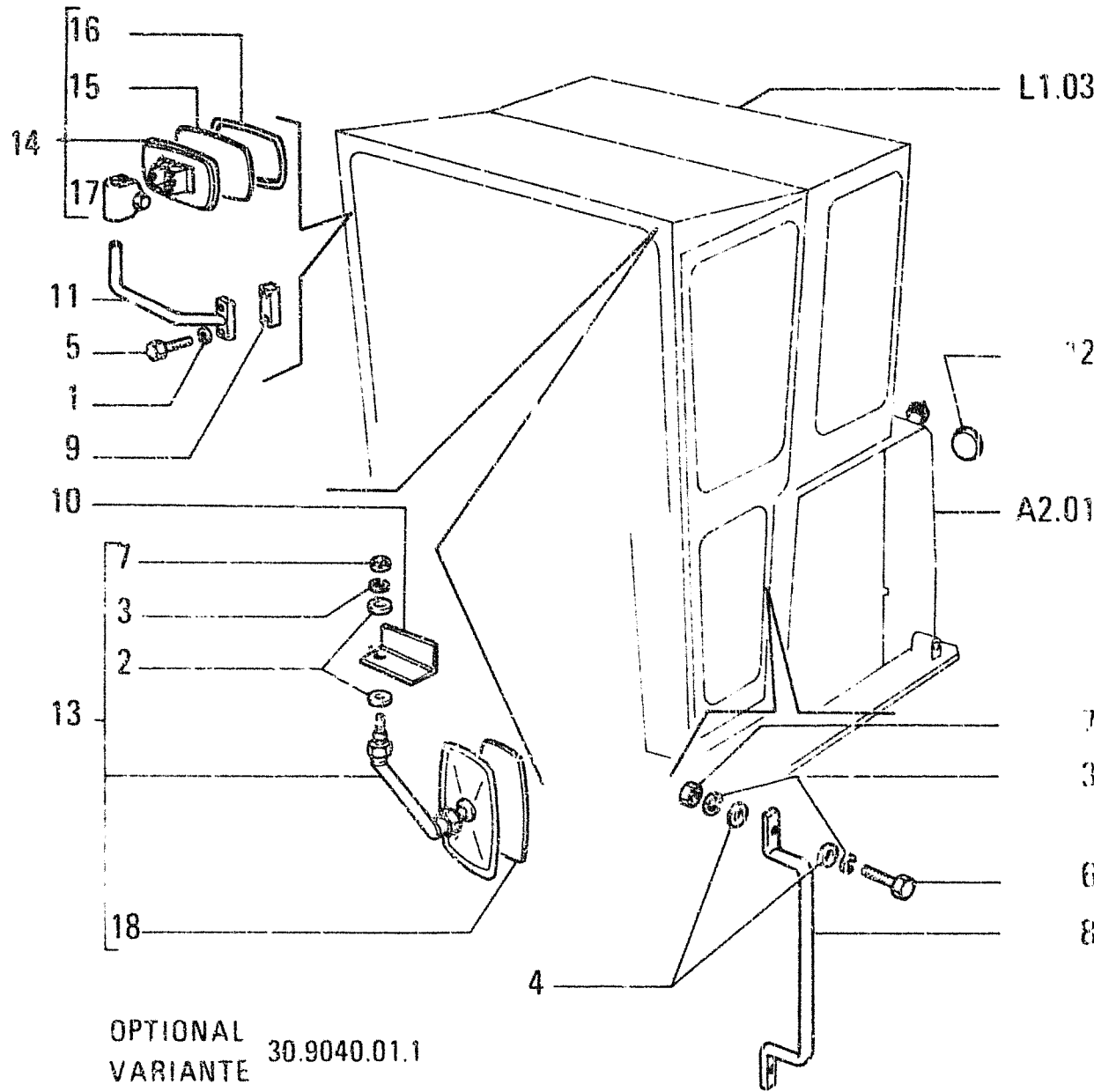

OPTIONAL
VARIANTE 30.9040.01.1

ITEM	PART NUMBER	QTY	TRANS CODE	DESCRIPTION	DESCRIZIONE
1	10516879	2	170R	LOCKWASHER 10,2x2,5	ROSETTA EL. 10,2x2,5
2	10519601	2	131R	WASHER 8,15x17	ROSETTA 8,15x17
3	10571779	5	170R	LOCKWASHER 8,1x2	ROSETTA EL. 8,1x2
4	14496521	8	131R	WASHER 8,4x17	ROSETTA 8,4x17
5	15970531	2	40V	SCREW 10x1,25x20	VITE 10x1,25x20
6	16044031	4	40V	SCREW 8x1,25x40	VITE 8x1,25x40
7	16100821	5	10D	NUT 8x1,25x6,5	DADO 8x1,25x6,5
8	73052024	2	20M	HANDLE	MANIGLIA
9	76008340	1	74B	BLOCK - TO BE WELDED	BLOCCHETTO - DA SALDARE
10	76008341	1	60A	ANGLE - TO BE WELDED	ANGOLARE - DA SALDARE
11	76008344	1	300S	SUPPORT	SUPPORTO
12	76008360	2	90C	REFLECTOR	CATADIOTTRO
13	79018675	1	185S	REAR VIEW MIRROR - INNER ASSEMBLY	SPECCHIO RETROVISORE - INTERNO COMPLETO
14	79044789	1	185S	REAR VIEW MIRROR - OUTER ASSEMBLY	SPECCHIO RETROVISORE - ESTERNO COMPLETO
15	79046237	1	38V	PANEL OF GLASS	VETRO
16	79046238	1	295C	BEZEL	CORNICE
17	79046240	1	225S	BRACKET	STAFFA
18	*	1	38V	PANEL OF GLASS	VETRO

PARTS MARKED * ARE NOT SUPPLIED AS SPARE'S
I PARTICOLARI CONTRASSEGNA TI CON * NON
VENGONO FORNITI DI RICAMBIO

GERMAN VERSION - ALLESTIMENTO GERMANIA - EQUIPMENT ALLEMAGNE - AUSRUSTUNG FUR
DEUTSCHLAND - TIPO ALEMANIA

M1.02

N.T.R. 191 - 20.02.1990

604.01.081.04

M7

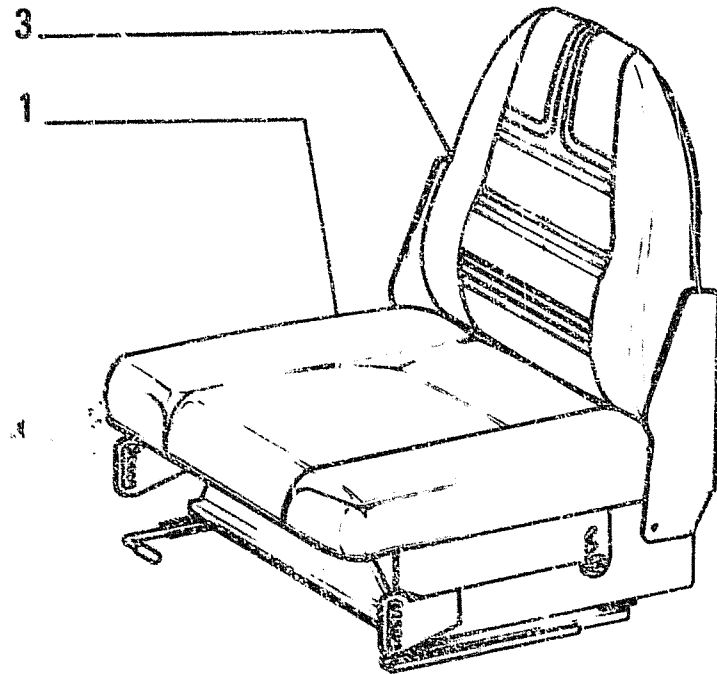

ITEM	PART NUMBER	QTY	TRANS CODE	DESCRIPTION	DESCRIZIONE
1	79026566	1	345C	CUSHION	CUSCINO
2	79036898	1	36A	SHOCK ASSORBER	AMMORTIZZATORE
3	79037996	1	50S	SEAT BACK	SCHIENALE

OPTIONAL
VARIANTE 30.0852.05.1

79012583

SEAT - SEDILE - SIEGE - SITZ - ASIEN TO

L6.04

N.T.R. 158 - 13.03.1987
604.01.081.03

M8

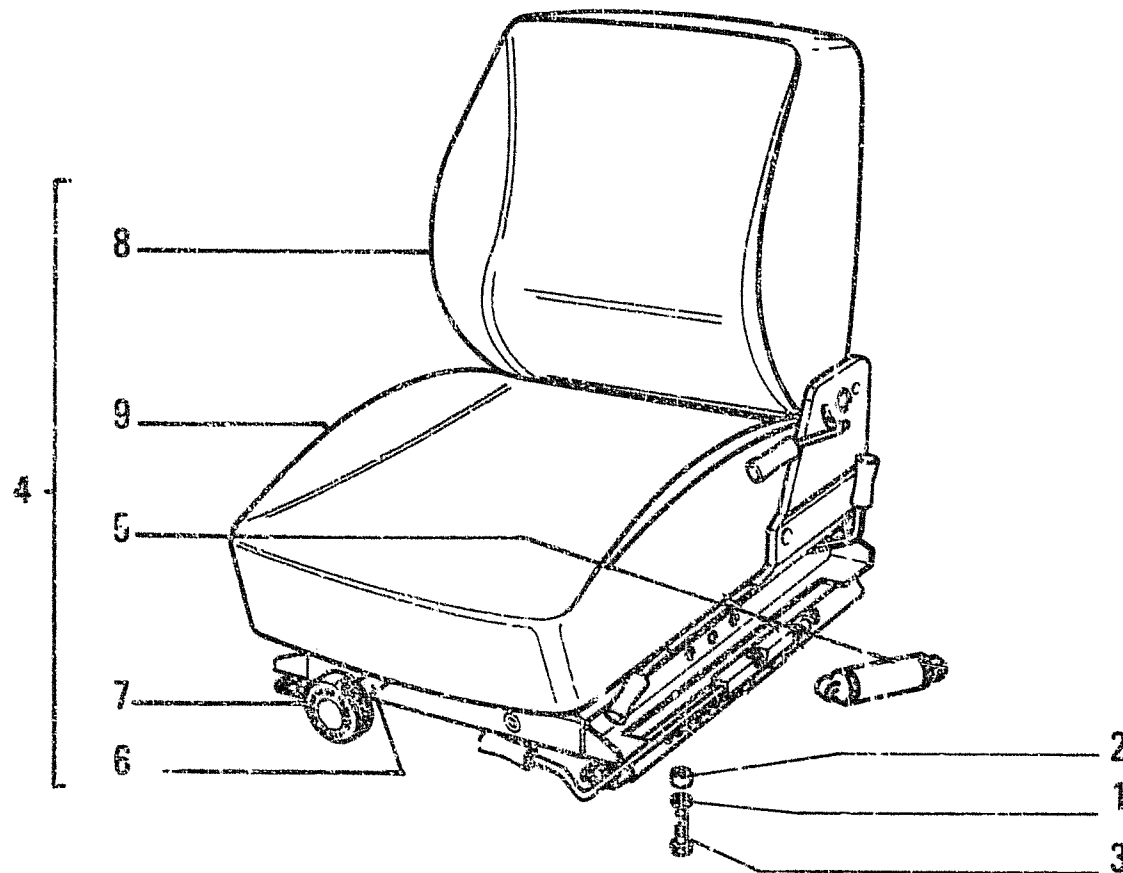

OPTIONAL 30.0853.01.1
VARIANTE

ITEM	PART NUMBER	QTY	TRANS CODE	DESCRIFTION	DESCRIZIONE
1	10516671	4	132R	LOCKWASHER 8,1x2,2	ROSETTA DI SICUREZZA 8,1x2,2
2	13605711	4	75D	SPACER 8,5x5	DISTANZIALE 8,5x5
3	16043631	4	40V	SCREW 3x1,25x25	VITE 8x1,25x25
4	79036696	1	80S	SEAT - ASSEMBLY	SEDILE - COMPLETO
5	79044469	1	36A	SHOCK ABSORBER	AMMORTIZZATORE
6	79044457	1	80P	PIN	PERNO
7	79044458	1	150P	KNOB	POMELO
8	79044438	1	50S	SEAT BACK	SCHIENALE
9	79060061	1	345C	CUSHION	CUSCINO

DRIVER'S SEAT - SEDILE CONDUTTORE - SIEGE DE CONDUCTEUR - FAHRERSITZ -
ASIENTO DEL CONDUCTOR

3

L6.01/2

N.T.R. 158 - 13.03.1987
604.01.081.03

M9

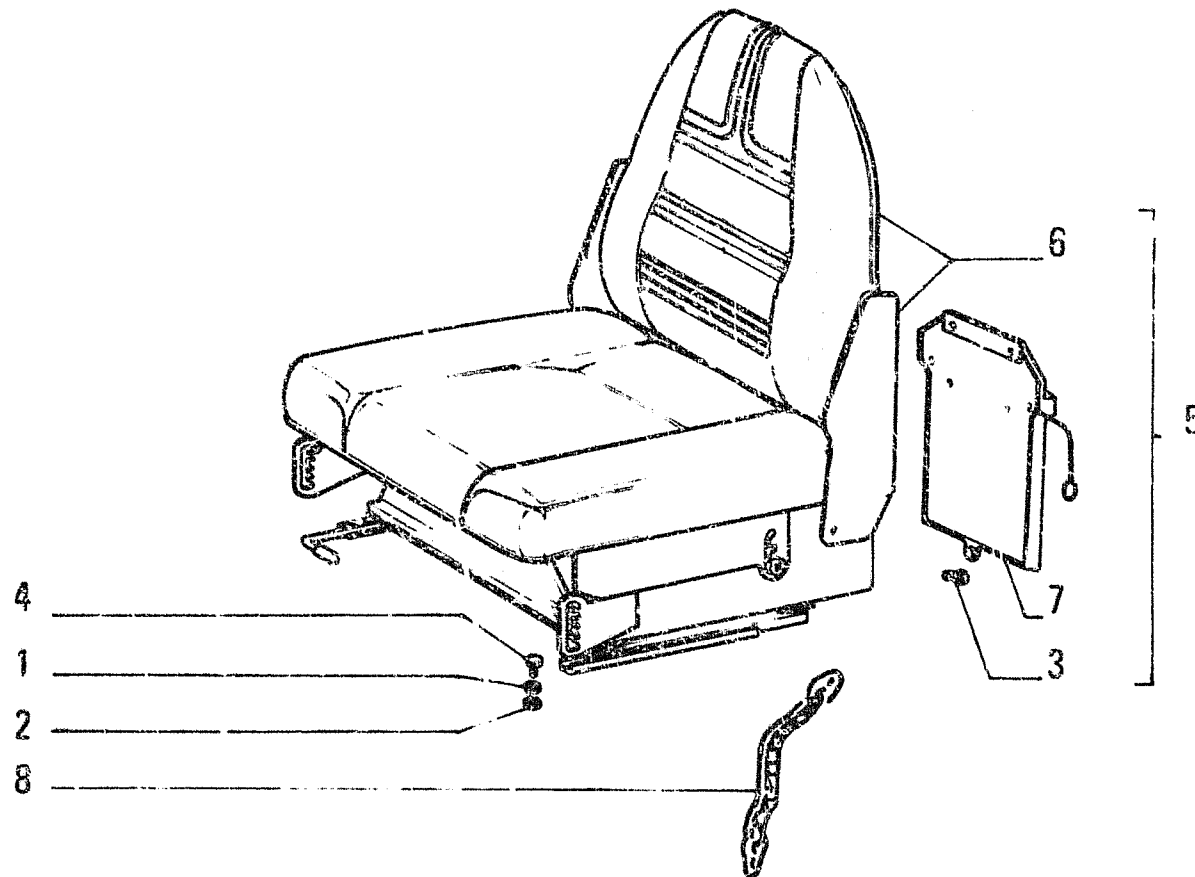

ITEM	PART NUMBER	QTY	TRANS CODE	DESCRIPTION	DESCRIZIONE
1	10516671	4	132R	LOCKWASHER 8,1x2,2	ROSETTA DI SICUREZZA 8,1x2,2
2	13605711	4	75D	SPACER 8,5x5	DISTANZIALE 8,5x5
3	15663101	3	40V	SCREW 4,2x13	VITE 4,2x13
4	16043621	4	40V	SCREW 8x1,25x25	VITE 8x1,25x25
5	76002402	1	80S	SEAT - ASSEMBLY	SEDILE - COMPLETO
6	79012583	1	80S	SEAT - ASSEMBLY SEE SGR. L6.04	SEDILE - COMPLETO VEDERE SGR. L6.04
7	79023080	1	109B	UTILITY RECESS	BORSA PORTACARTE
8	79035976	2	142T	TIEROD	TIRANTE

OPTIONAL
VARIANTE 30.0852.05.1

DRIVER'S SEAT - SEDILE CONDUTTORE - SIEGE DE CONDUCTEUR - FAHRERSITZ - ASIENTO DEL CONDUCTOR

L6.01/1

N.T.R. 158 - 13.03.1987
604.01.081.03

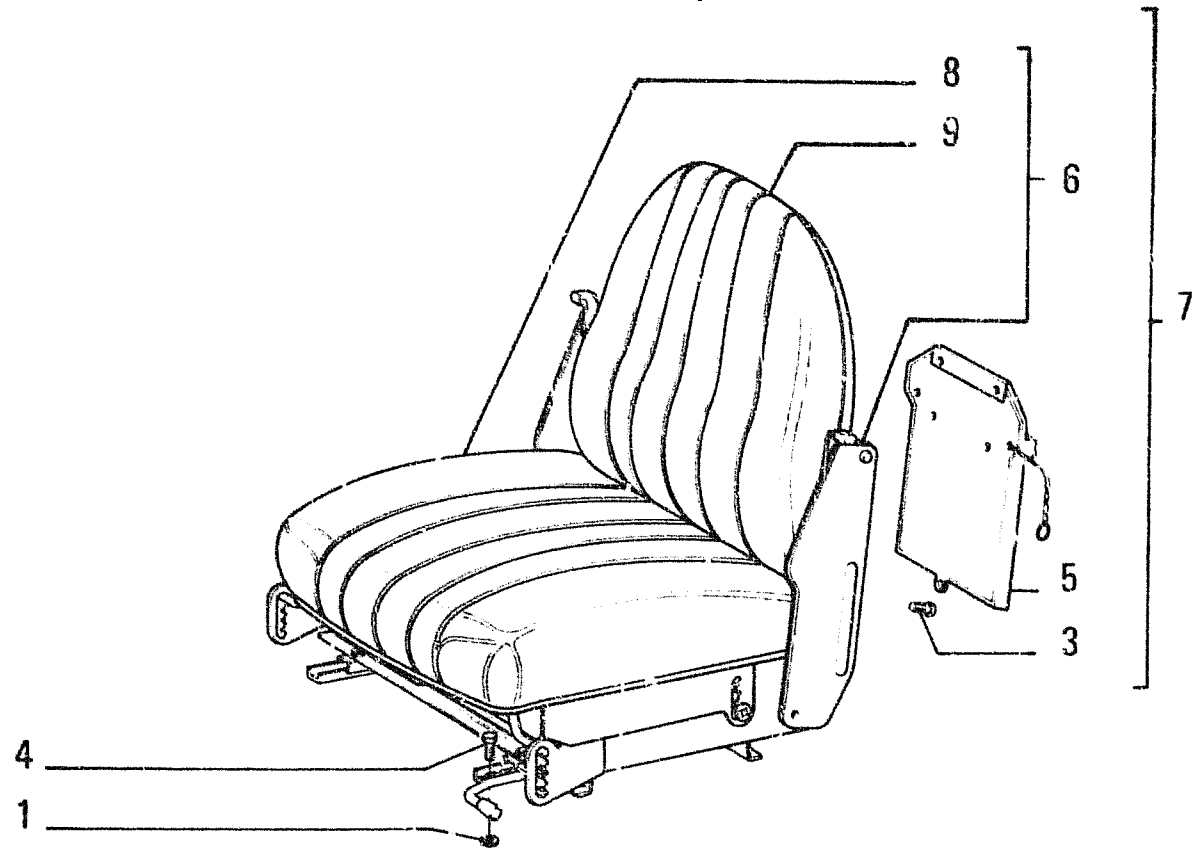

ITEM	PART NUMBER	QTY	TRANS CODE	DESCRIPTION	DESCRIZIONE
1	10510871	4	132R	LOCKWASHER 8,1x2,2	ROSETTA DI SICUREZZA 8,1x2,2
3	15663101	3	40V	SCREW 4,2x13	VITE 4,2x13
4	16043631	4	40V	SCREW 8x1,25x25	VITE 8x1,25x25
5	79023080	1	109B	UTILITY RECESS	BORSA PORTACARTE
6	79024350	1	80S	SEAT - ASSEMBL /	SEDILE - COMPLETO
7	79024644	1	80S	SEAT - ASSEMBLY	SEDILE - COMPLETO
8	79026297	1	345C	CUSHION	CUSCINO
9	79026298	1	50S	SEAT BACK	SCHIENALE

DRIVER'S SEAT - SEDILE CONDUTTORE - SIEGE DE CONDUCTEUR - FAHRERSITZ - ASIENTO DEL CONDUCTOR

L6.01

M11

N.T.R. 158 - 13.03.1987
604.01.081.03

SERIE TARGHE
 DECAL KIT
 BAUSALZ ABZIEHBILDER
 KIT DES DECALCOMANIES
 JUEGO DE CALCOMANIAS
 JOGO DE ETIQUETAS



ITEM	PART NUMBER	QTY	TRANS CODE	DESCRIPTION	DESCRIZIONE
	79023782	1	2K	KIT -ITALIANO (*)	KIT -ITALIANO (*)
	79023783	1	2K	KIT -ENGLISH (1*)	KIT -ENGLISH (1*)
	79023784	1	2K	KIT -DEUTSCH (2*)	KIT -DEUTSCH (2*)
	79023785	1	2K	KIT -FRANCAIS (3*)	KIT -FRANCAIS (3*)
	79023786	1	2K	KIT -ESPANOL (4*)	KIT -ESPANOL (4*)
	79023787	1	2K	KIT -PORTUGUES (5*)	KIT -PORTUGUES (5*)
	(*)		469P	FOR SPECIAL EQUIPMENT 30.0978.23.1	PER VARIANTE 30.0978.23.1
	(1*)		469P	FOR SPECIAL EQUIPMENT 30.0980.42.1	PER VARIANTE 30.0980.42.1
	(2*)		469P	FOR SPECIAL EQUIPMENT 30.0981.21.1	PER VARIANTE 30.0981.21.1
	(3*)		469P	FOR SPECIAL EQUIPMENT 30.0982.20.1	PER VARIANTE 30.0982.20.1
	(4*)		469P	FOR SPECIAL EQUIPMENT 30.0987.18.1	PER VARIANTE 30.0987.18.1
	(5*)		469P	FOR SPECIAL EQUIPMENT 30.0986.18.1	PER VARIANTE 30.0986.18.1

MAKE-MEDALLIONS - TARGHE - MOTIFS - KENNZEICHEN - EMBLEMAS

L4.10

N.T.R. 191 - 20.02.1990

604.01.081.04

M12

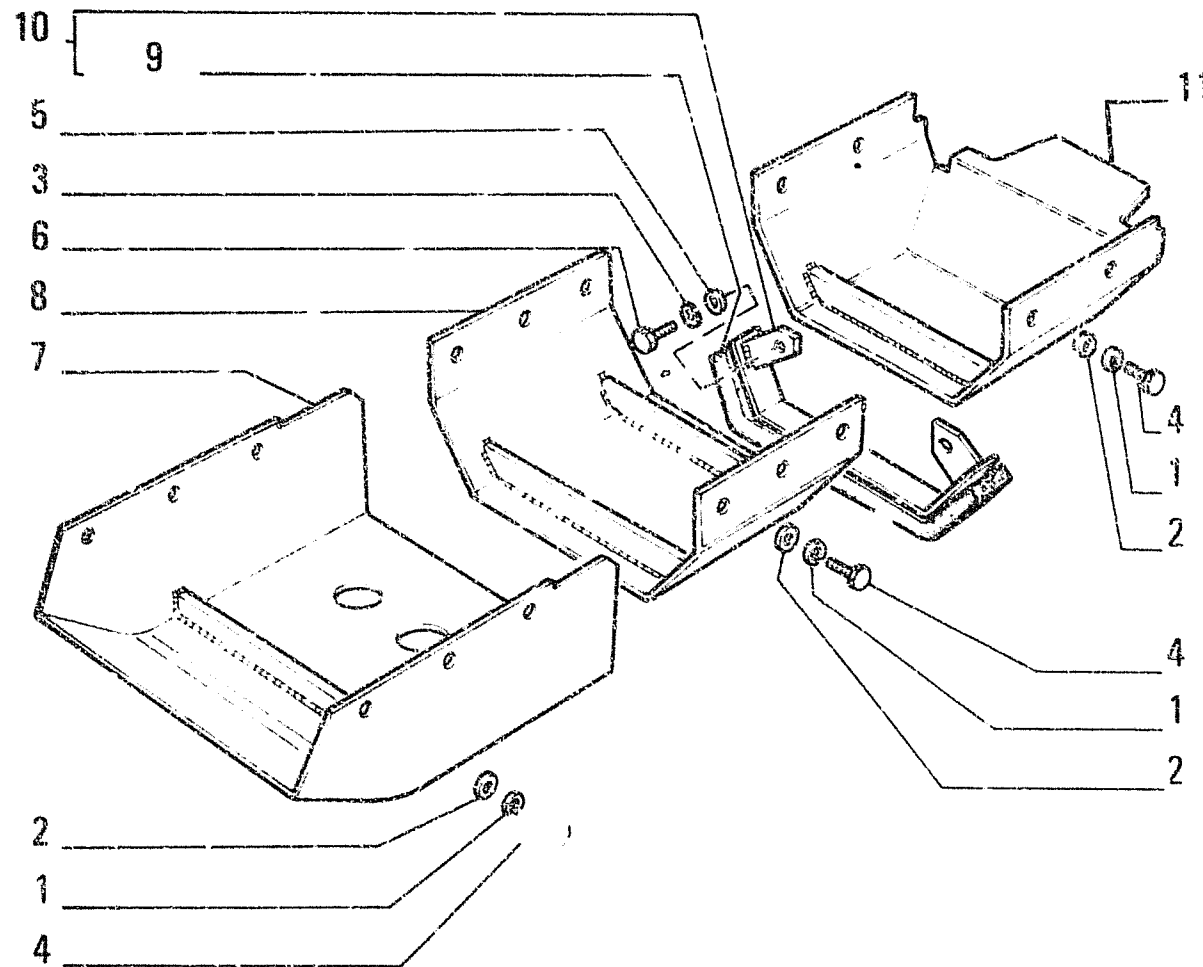

ITEM	PART NUMBER	QTY	TRANS CODE	DESCRIPTION	DESCRIZIONE
1	10517171	16	132R	LOCKWASHER 14,2x3,5	ROSETTA DI SICUREZZA 14,2x3,5
2	10520121	16	133R	SEAL 14,4x26	ROSETTA DI TENUTA 14,4x26
3	10571771	2	132R	LOCKWASHER 8,1x2	ROSETTA DI SICUREZZA 8,1x2
4	11115631	16	40V	SCREW 14x2x35	VITE 14x2x35
5	12642021	2	133R	SEAL 8,15x25	ROSETTA DI TENUTA 8,15x25
6	16043631	2	40V	SCREW 6x1,25x25	VITE 6x1,25x25
7	79017647	1	70R	GUARD - LOWER	RIPARO - INFERIORE
8	79024418	1	70R	GUARD	RIPARO
9	79029864	1	120G	GASKET	GUARNIZIONE PIANA
10	79029865	1	14B	STRAP - ASSEMBLY	BANDELLA - COMPLETO
11	79035301	1	70R	GUARD	RIPARO

BOTTOM GUARDS - RIPARI INFERIORI - PROTECTIONS INFERIEURES - UNTERE SCHUTZBLECHE -
BLINDAJE INFERIOR

L3.12

M13

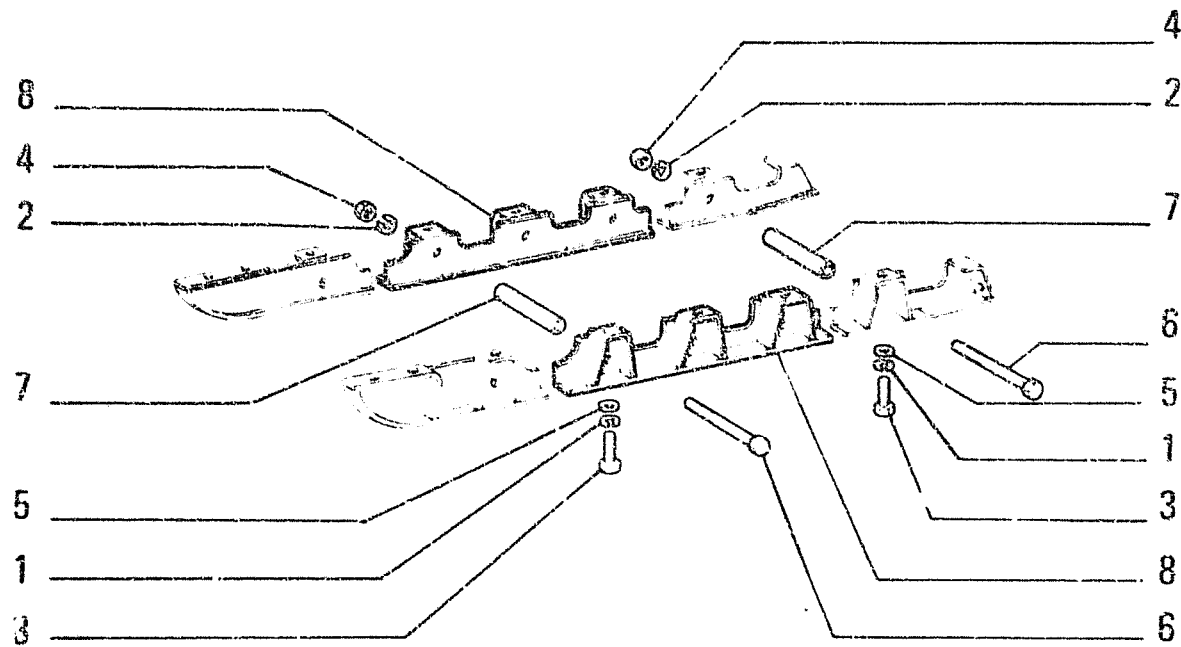

ITEM	PART NUMBER	QTY	TRANS CODE	DESCRIPTION	DESCRIZIONE
1	10517171	24	132R	LOCKWASHER 14,2x3,5	ROSETTA DI SICUREZZA 14,2x3,5
2	10517271	4	132R	LOCKWASHER 16,2x4	ROSETTA DI SICUREZZA 16,2x4
3	11255931	24	40V	SCREW 14x1,5x40	VITE 1 ...40
4	12164127	4	10D	NUT 16x1,5x13	DADO 16x1,5x13
5	79005258	24	131R	WASHER	ROSETTA
6	79022276	4	184C	STUD	COLONNETTA
7	79022277	4	75D	SPACER	DISTANZIALE
8	79024446	4	70R	GUARD	RIPARO

OPTIONAL
VARIANTE 30.0563.16.1

TRACK GUARDS - RIPARI CINGOLI - PROTECTIONS DE CHENILLES - RAUPENKETTENSCHUETZER -
BLINDAJE DE CADENAS

L3.11/1

M14

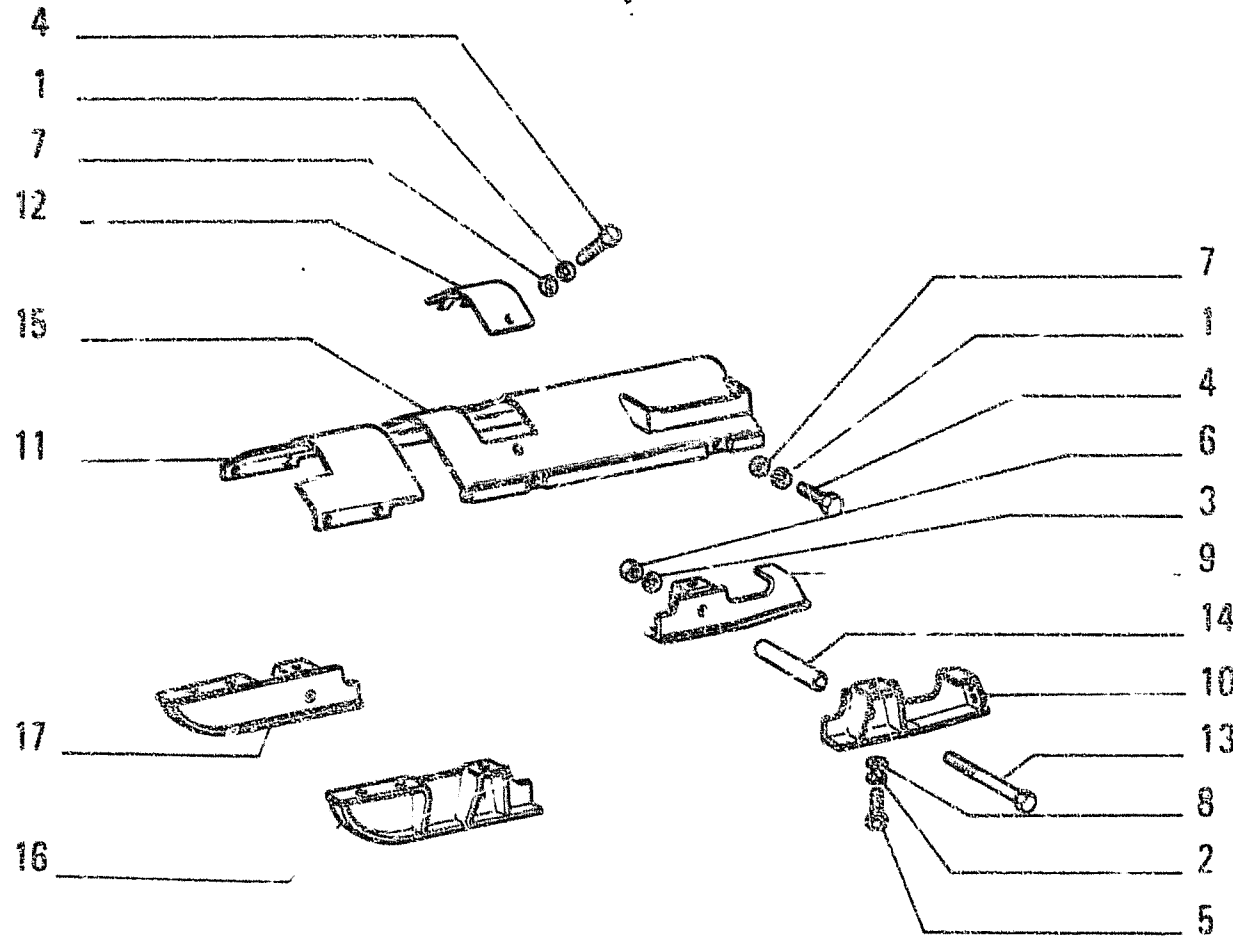

ITEM	PART NUMBER	QTY	TRANS CODE	DESCRIPTION	DESCRIZIONE
1	10516871	16	132R	LOCKWASHER 10x2,5	ROSETTA DI SICUREZZA 10x2,5
2	10517171	24	132R	LOCKWASHER 14,2x3,5	ROSETTA DI SICUREZZA 14,2x3,5
3	10517271	4	132R	LOCKWASHER 16,2x4	ROSETTA DI SICUREZZA 16,2x4
4	11106291	18	40V	SCREW 10x1,5x25	VITE 10x1,5x25
5	11255931	24	40V	SCREW 14x1,5x40	VITE 14x1,5x40
6	12164127	4	10D	NUT 16x1,5x13	DADO 16x1,5x13
7	12646821	18	131R	WASHER 10,2x25	ROSETTA 10,2x25
8	79005238	24	131R	WASHER	ROSETTA
9	79014282	2	70R	GUARD	RIPARO
10	79014283	2	70R	GUARD	RIPARO
11	79015317	1	70R	GUARD - LEFT	RIPARO - SINISTRO
	79015319	1	70R	GUARD - RIGHT	RIPARO - DESTRO
12	79022240	2	265C	COVER	COPERCHIO
13	79022276	4	184C	STUD	COLONNETTA
14	79022277	4	75D	SPACER	DISTANZIALE
15	79024337	1	70R	GUARD - RIGHT	RIPARO - DESTRO
	79024338	1	70R	GUARD - LEFT	RIPARO - SINISTRO
16	79022272	2	70R	GUARD	RIPARO
17	79022273	2	70R	GUARD	RIPARO

TRACK GUARDS - RIPARI CINGOLI - PROTECTIONS DE CHENILLES - RAUPENKETTENSCHUETZER -
BLINDAJE DE CADENAS

L3.11

N.T.R. 191 - 20.02.1990

604.01.081.04

M16

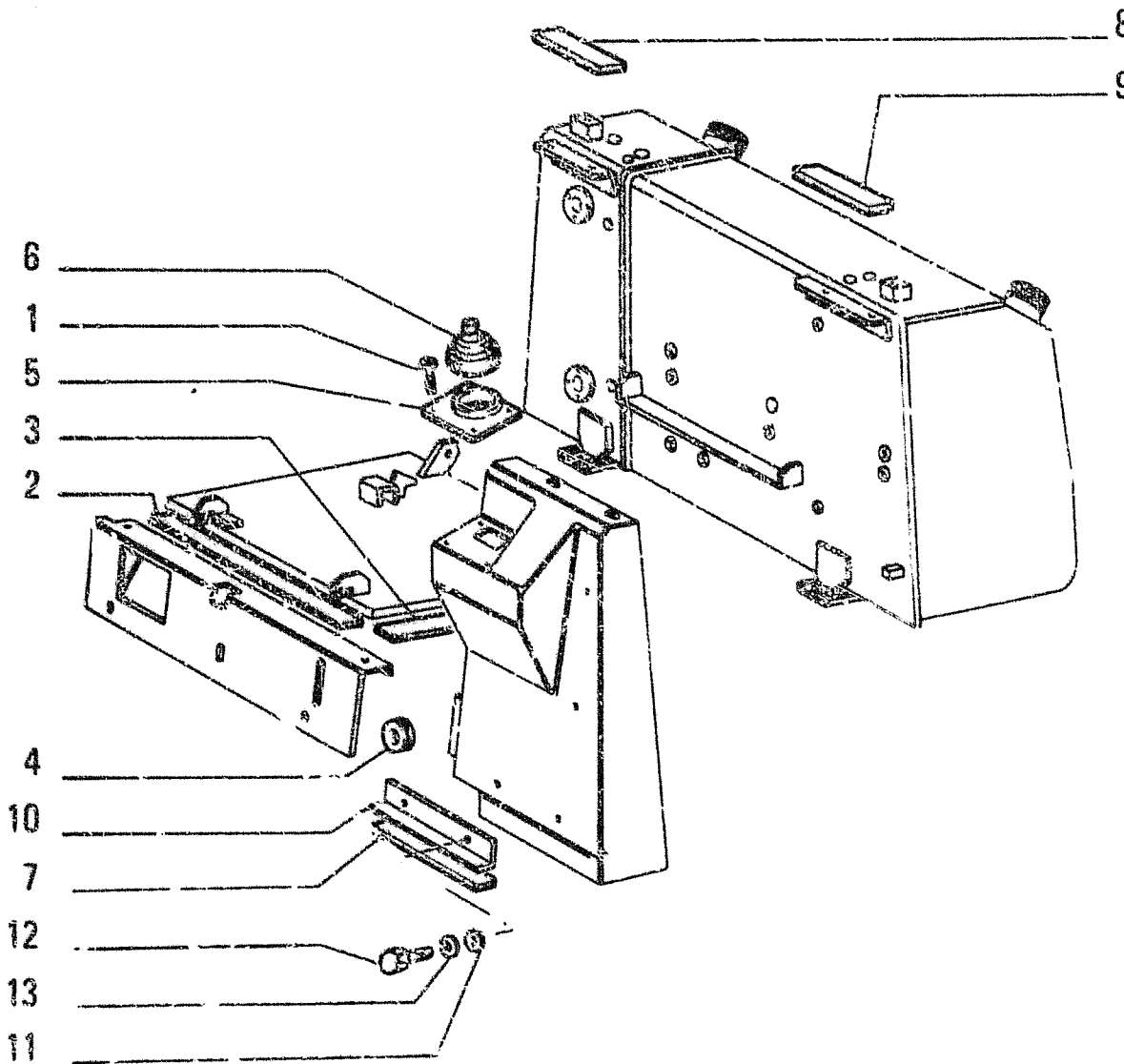

OPTIONAL
VARIANTE 30.0020.16 1

ITEM	PART NUMBER	QTY	TRANS CODE	DESCRIPTION	DESCRIZIONE
1	15645601	4	40V	SCREW 4,8x16	VITE 4,8x16
2	79035786	2	123G	SEAL ASSY	GUARNIZIONE TENUTA FRONTALE
3	79035787	2	123G	SEAL ASSY	GUARNIZIONE TENUTA FRONTALE
4	79035788	1	120G	GASKET	GUARNIZIONE PIANA
5	79035794	1	300S	SUPPORT	SUPPORTO
6	79035795	1	334C	DUST BOOT	CUFFIA PARAPOLVERE
7	79037639	2	123G	SEAL ASSY	GUARNIZIONE TENUTA FRONTALE
8	79037640	1	123G	SEAL ASSY - RIGHT	GUARNIZIONE TENUTA FRONTALE - DESTRO
9	79037641	1	123G	SEAL ASSY - LEFT	GUARNIZIONE TENUTA FRONTALE - SINISTRO
10	79030649	1	70R	GUARD - LEFT	RIPARO - SINISTRO
	79030650	1	70R	GUARD - RIGHT	RIPARO - DESTRO
11	10516871	4	170R	LOCKWASHER 10x2,5	ROSETTA EL 10x2,5
12	11106231	4	40V	SCREW 10x1,5x25	VITE 10x1,5x25
13	12646821	4	131R	WASHER 10,2x25	ROSETTA 10,2x25

SEAT PANELS
ASIENTO

RIPARI SEDILE - PROTECTIONS DE SIEGE - SITZSCHUETZER - PROTECCIONES DEL

L3.10/1	2
N.T.R. 158 - 13.03.1987	
604.01.081.03	

M17

DESIGNAZIONE BASE	BASIC DESIGNATION	DESIGNATIONS-BASES	GRUNDBEZEICHNUNGEN	DEMININACIONES BASE	
168T	TRASPARENTE DELL'INDICATORE DI DIREZIONE	DIRECTION INDICATOR LAMP LENS	TRANSPARENT D'INDICATEUR DE DIRECTION	LICHTSCHEIBE DER BLINKLEUCHTE	TAPA TRANSLUCIDA DEL INDICADOR DE DIRECCION
168T					
168T					
169C	CILINDRO DI DISINNESTO	RELEASE CYLINDER	CYLINDRE DE DEBRAYAGE	ARBEITSZYLINDER	CILINDRO DE EMBRAGUE
169C					
169P	POMPETTA	PUMP, WASHER	POMPE	PUMPE	BOMBA
169P	REGOLATORE	REGULATOR	REGULATEUR	REGLER	REGULADOR
169T	TRASPARENTE CON CATADIOPTRO	LENS AND REFLEX-REFLECTOR	TRANSPARENT ET CATADIOPTRE	LICHTSCHEIBE MIT RUECKSTRAHLER	TAPA TRANSLUCIDA CON CATAFAROS
169T					
170A	RAFFREDDAMENTO MOTORE	ENGINE COOLING SYSTEM	REFROIDISSEMENT MOTEUR	LEITUNGEN MOTORKUEHL SYSTEM	
170A					
170B	TUBAZIONI RAFFREDD. MOTORE	ENGINE COOLING PIPING		DICHTUNG FUER LUFTANLAGE	
170B					
170S	ELEMENTI TENUTA ARIA	AIR-TIGHT ELEMENT	ELEMENTS ETANCHEITE D'AIR	HAUPTZYLINDER	CILINDRO PRINCIPAL
170C	CILINDRO MAESTRO	MASTER CYLINDER	MAITRE-CYLINDRE	ANHAENGERKUPPLUNG	BRIDA
170P	PONTECELLO	BRIDGE PIECE	CHAPE D'ATTELAGE	FEDERRING	ARANDELA DE FRENO
170R	ROSETTA EL.	LOCKWASHER	RONDELLE A RESSORT	ENTSTOERNER	SUPRESOR
170P	SOPPRESSORE	SUPPRESSOR	RESISTANCE	LICHTSCHEIBE	TRANSLUCIDO
170T	TRASPARENTE	LENS	TRANSPARENT	ZYLINDER	CILINDRO DE MANCO
171C	CILINDRO OPERATORE	OPERATING CYLINDER	CYLINDRE DE COMMANDE		
171C					
171R	REFLETTORE	REFLECTOR	REFLECTEUR	REFLECTOR	REFLECTOR
171B	SOPRASUOLA	STREET PLATE	PATIN DE ROUTE	STRASSENSCHUH	PATIN DE CARRETERA
172C	CINGHIA DI FISSAGGIO	SECURING STRAP	SANGLE DE FIXATION	HALTERIEMEN	CORREA DE FIJACION
172S	SUSPENSIONE	SUSPENSION	SUSPENSION	AUFHAENGUNG	SUSPENSION
173C	CINGHIA	BELT	COURROIE	KEHLRIEMEN	CORREA
173R	RALLA ROTAZIONE	BULL GEAR	ORAPAUDINE	DREHKRANZ	RUEDA DE DIENTES-EXCAVADORA
174C	CINGHIE	BELTS	COURROIES	RIEMEN	CORREAS
174R	RALLA PORTALAMA	CIRCLE	CERCLE	KUGELAUFNAPPE	RUELA DE DIENTES-MOTONIVELADOR
174S	SOSTEGNO	BRACE	SUPPORT	STUETZE	SOPORTE
175R	REGOLATORE MECCANICO	GOVERNOR	REGULATEUR	MECHANISCHER REGLER	REGULADOR
176C	COPANO	HOOD	CAPOT	MOTORHAUBE	CAPOT
176R	RUSPA	SCRAPER	DEGROTOIR	ABSTREICHER	LIMPIADOR
177R	HUOTA COMPATTATORE	PADFOOT WHEEL			
177S	SPAZZOLA	BRUSH	BALAIS	KOHLENBUERSTE	ESCOBILLA
178C	CINGOLO	TRACK	CHENILLE	RAUPENKETTE	ORUGA
180C	COLLARE	COLLAR	COLLIER	ROHRSCHELLE	COLLAR
180P	PORTA	DOOR	PORTE	TUER	PUERTA
180T	TRAVERSA	CROSS BEAM	TRAVERSE	TRAVERSE	TRAVESANO
181T	TRAVERSA DI TRAINO	DRAWBAR FRAME	TRAVERSE D'ATTELAGE	ACKERSCHIENE	TRAVIESA PERFORADA
181T					
182C	CINTURA DI SICUREZZA	SAFETY BELT	CEINTURE DE SECURITE	SICHERHEITSGURT	CINTURON DE SEGURIDAD

DESIGNAZIONE BASE	BASIC DESIGNATION	DESIGNATIONS-BASES	GRUNDBEZEICHNUNGEN	DETERMINACIONES BASE
1821	SOLLEVATORE IDRAULICO (VELOCE)		RELEVAGE HYDRAULIQUE (RAPIDE)	
183P	PORTACENERE	ASHTRAY	CENDRIER	CENICERO
184C	COLONNETTA	STUD	COLONNETTE	COLUMNA
184S	SPECCHIO	MIRROR	MIROIR	ESPEJO
185C	CHIODO	NAIL	CLOU	CLAVO
185P	PORTACONTATTI	CONTACT CARRIER	PORTE-CONTACTS	CAJA DE BORNAS
185S	SPECCHIO RETROVISORE	REAR VIEW MIRROR	RETROVISEUR	ESPEJO RETROVISOR
186A	ALBERO RETROMARCIA	REVERSE SHAFT	ARBRE ARRIERE	ARBOL MARCHA ATRAS
187A	ANELLO ELASTICO	SNAP RING	ARRETOIR	AROS ELASTICOS
187C	COMANDO CADUTA LIBERA DI EMERGENZA	FREE FALL CONTROL	COMMANDE DE CHUTE GENCE	MANDO DE CAIDA LIB EMERGENCIA
188A	APPENDIABITI	COAT HOOK	PORTEMANTEAUX	COLGADOR
189C	COLLETTORE	MANIFOLD	COLLECTEUR	COLECTOR
189P	PORTAFUSIBILE	FUSE HOLDER	PORTE-FUSIBLE	PORTAFUSIBLE
189A	ATTUATORE DI ROTAZIONE	SLEWING ACTUATOR	GROUPE DE ROTATION	MECANISMO DE ROTACION
189C	COMANDO	CONTROL	COMMANDE	MANDO
1897	TUBAZIONE MOTORE-FILTRO ARIA	ENGINE TO AIR CLEANER LINES		
190A	ARRICCHITORE	EXCESS FUEL	DISPOSITIF CONTROLE INTRODUCTION	SUPLEMENTO DE INYECCION
190A			COMMANDE A MAIN SPECIAL POUR RECHANGES	
190C	COMANDO A MANO	HAND CONTROL	TUYAU	MANDO MANUAL
190S	SPECIALE PER RICAMBI	SPECIFIC FOR REPLACEMENTS	COMMANDE AU PIED	ESPECIAL PARA RE- CAMBIOS
190S			COMMANDE D'AVERTISSEUR	TUBO
190T	TUBAZIONE	LINE	COMMANDE PNEUMATIQUE	PEDAL
191C	COMANDO A PEDALE	FOOT CONTROL	PORTE-OBJETS	PULSADOR DE BOCINA
192C	COMANDO DELL'AVVISATORE	HORN BUTTON	TUYAU FLEXIBLE	
192C			COMMANDE PNEUMATIQUE	
192P	PORTAOGGETTI	UTILITY HOLDER	QUE	PORTAOBJETOS
192T	TUBO FLESS.C./RACCORDI	HOSE ASSY	PORTE-LAMPE	TUBO FLEXIBLE
193C	COMANDO PNEUMATICO	AIR CONTROL	TUYAU	MANDO NEUMATICO
193C			COMMANDE ELECTRO-PNEUMATIQUE	
193P	PORTALAMPADA	BULB HOLDER	TIRETTE DE COMMANDE	SOPORTE DE LAMPARA
193T	TUBO RIGIDO	TUBE	PORTE-PULVERISATEUR	TUBO
194C	COMANDO ELETTROPNEUMATICO	ELECTRO-PNEUMATIC CONTROL	TUBE	MANDO ELECTRO-NEU- MATICO
194C			PORTE-SATELLITES	MANDO FLEXIBLE
195C	COMANDO FLESSIBILE	BOWDEN ASSY.		
195C				
195P	PORTAPOLVERIZZATORE	NOZZLE HOLDER	DUESENSTOCK	PORTAINYECTOR
195T	TUBETTO	TUBE	ROHR	TUBO
195T			PLANETENTRAEGER	EJE DE SATELITES
195P	PORTASATELLITI	PLANETARY HUB		

	DESIGNAZIONE BASE	BASIC DESIGNATION	DESIGNATIONS-BASES	GRUNDBEZEICHNUNGEN	DENOMINACIONES BASE
196S	SPEIRONE	TRACK FRAME END	GUIDE CHENILLES	KETTENFUHRUNG	ESPOLON
196T	TUBETTO ISOLANTE	INSULATING SHEAT	TUBE ISOLANT	ISOLIERHUELLE	TUBO AISLANTE
197C	COMANDO ACCELERATORE	THROTTLE CONTROL	COMMANDE D'ACCELERATEUR	GASREGULIERUNG	MANDO DEL ACELERADOR
197P	PORTASPAZZOLA	BUSH HOLDER	PORTE-BALAI	BUERSTENTRAEGER	PORTAESCOBILLA
197S	SPESSORE ELASTICO	PAD	CALE ELASTIQUE	ELASTISCHE UNTER- LAGE	SUPLEMENTO ELA- STICO
197S				HUELSE	TUBITO DE FIJACION
197T	TUBETTO STRINGIFILO	FERRULE	TUBE D'ATTACHE	STARTVORRICHTUNG	MANDO MANUAL DE STARTER
198C	COMANDO A MANO STARTER	CHOKE CONTROL	COMMANDE A MAIN DE STARTER		
198C				KENNZEICHENHALTER	SOPORTE DE PLACA
198P	PIASTRA PORTATARGA	PLATE SUPPORT	PORTE-PLAQUE	DISTANZSCHEIBE	ESPESOR
198S	SPESSORE	SHIM	CALE D'EPaisseur	SCHNEIDE	CUCHILLA
198K	COLTELLO SENNA	BUCKET CUTTING EDGE	COUTEAU DU CODET	DICKENMESSGERAET	CALIBRE
198S	SPESSIMETRO	FEELER GAUGE	JAUGE D'EPaisseur	INNENSICHERUNG	PESTILLO DE SEGU- RIDAD
200C	COMANDO SICUREZZA	SAFETY CONTROL	COMMANDE DE SECU- RITE	DRUCKFEDER	ELEMENTO SEPARADOR
200C				STIFT	PASADOR
200P	PREMIGUARNIZIONE	EXPANDER	PRESSE-JOINT	EINFUELLSTUTZEN	CUELLO DE CARGA
200S	SPINA	PIN	SORPILLE		
200T	TUBO DI INTRODUZIONE	FILLER TUBE	TUBULURE DE REM- PLISSAGE		
200T				AUTOMATISCHES AUSLASSVENTIL	VALVULA DE DESCAR- GA AUTOMATICA
200V	VALVOLA AUTOMATICA DI SCARICO	AUTOMATIC DRAIN VALVE	SOUPAPE AUTOMATI- QUE DE DETENTE	VORABSCHIEDER	PREFILTRO
200V				STECKER	ENCHUFE
201P	PREFILTRO	PRECLEANER	PREFILTRE	AUTOMATISCHES ABLASSVENTIL	VALVULA DE PURGA AUTOMATICA
201S	SPINA ELETTRICA	ELECTRICAL PLUG	FIGE ELECTRIQUE	ZUENDANLASSCHALTER MIT LENKSCHLOSS	COMUTADOR CON DISP.ANTIRROBO
201V	VALVOLA AUTOMATICA DI SPURGO	AUTOMATIC BLEED VALVE	PURGEUR AUTOMATI- QUE	RUECKSTELLVORRICHTUNG	POSICIONADOR
201V				SPANNSTIFT	PASADOR ELASTICO
202C	COMUTATORE CON ANTIFURTO	KEY SWITCH W/ANTITHEFT DEVICE	COMMUTATEUR AVEC ANTIVOL	BORDWAND	LADO
202C				ZUFUHRVENTIL	VALVULA DE ALI- MENTACION
202P	POSIZIONATORE	POSITIONER	POSITIONNEUR	LUFYANSCHLUSS	BOCA DE AIRE
202S	SPINA ELASTICA	SPRING PIN	GOUPILE ELASTIQUE	STECKDOSE	TOMA DE CORRIENTE
203S	SPONDA	SIDE	RIDELLE	KLAPPE	POSTIGO
203V	VALVOLA DI ALIMENTAZIONE	FEED VALVE	SOUPAPE D'ALIMEN- TATION	ZAPFWELLE	TOMA DE FUERZA
203V				ENTLUFTUNGSLEI- TUNG	TUBO DE VENTILA- CION
204P	PRESA ARIA	AIR INTAKE	PRISE D'AIR	TURBINE	TURBINA
205P	PRESA DI CORRENTE	RECEPTACLE	PRISE DE COURANT		
205S	SPORTELLI	DOOR	VOLET		
207P	PRESA DI FORZA	POWER TAKE-OFF	PRISE DE FORCE		
207T	TUBO DI SPIATO	VENT PIPE	TUBE D'EVENT		
207T					
209T	TURBINA	TURBINE	TURBINE		
2163	ARTICOLAZIONE TELAI	MAIN FRAME ARTICULATION	ARTICULATION DES CHASSIS		

NORTH AMERICA VERSION ONLY
VERSIONE SOLO PER NORD AMERICA

The attached pages are an addition to the machine's parts catalog.
These additional items are not covered in the main parts catalog but are in this supplement.

Le pagine che seguono sono una aggiunta al catalogo base di questo modello.
Le parti elencate in questa sezione non sono comprese negli elenchi ed indici del catalogo principale, ma soltanto in questa sezione supplementare.

Les pages ci-après sont un additif au catalogue de base de ce modèle.
Les pièces énumérées dans cette section ne figurent pas dans les listes et dans les index du catalogue principal, mais seulement dans cette section supplémentaire.

Die folgenden Seiten sind ein Nachtrag zum Hauptkatalog dieses Modells.
Die in diesem Abschnitt angeführten Teile sind nicht in den Listen und Verzeichnissen des Hauptkatalogs, sondern nur in diesem Nachtrag enthalten.

Las páginas que van a continuación constituyen un apéndice del catálogo básico de este modelo. Las piezas aquí reseñadas no salen en las listas e índices del catálogo principal, sino tan solo en este suplemento.

FD7 ALPHABETICAL INDEX

ALARM INDICATING DEVICE	F401 (3A)
BACK-UP ALARM	F501 (2)
BATTERIES & CABLES	F301
BRAKE CONTROL	C101(1)
COLD WEATHER START	A243
COUNTERWEIGHT	B408 (2)
FILTER CARE KITS	2
LADDER, HANDRAIL & FENDERS	L304 (1)
LIGHTS & WIRING	F401 (1)
LIGHT ASSEMBLY	F629 (1)
PAINTING AND MARKING	5
REAR FLOOD LIGHT	F401 (4)
SEAT	L601/1
STEERING CONTROL VALVE	D229 (1),(2)
STEERING CLUTCH CONTROL	D222 (1)
TRACK	D340/1 (1)

"FILTER CARE" KIT
MODEL: FD7 PRIOR TO S/N 250904

250 HOUR KIT

PART NUMBER: 75124813

<u>QUANTITY</u>	<u>PART NUMBER</u>	<u>DESCRIPTION</u>
1	10263460	ENGINE OIL DRAIN GASKET
2	04630787	LUBE OIL FILTER
1	73118171	TRANSMISSION FILTER

NOTE: Clean and reuse:

Fuel inlet strainer - 00700314

Transmission suction strainer - 71004849

"FILTER CARE" KIT
MODEL: FD7 PRIOR TO S/N 250904

500 HOUR KIT

PART NUMBER: 75124814

<u>QUANTITY</u>	<u>PART NUMBER</u>	<u>DESCRIPTION</u>
1	10263460	ENGINE OIL DRAIN GASKET
2	04630787	LUBE OIL FILTER
1	73118171	TRANSMISSION FILTER
1	04788503	FILTER - FUEL
1	71004848	TRANSMISSION GASKET STRAINER
1	70924166	O'RING HYDRAULIC FILTER
1	79026104	STEERING FILTER
1	78032087	HYDRAULIC OIL FILTER

NOTE: Clean and reuse:

Fuel inlet strainer - 00700314

Transmission suction strainer - 71004849

"FILTER CARE" KIT
MODEL: FD7 PRIOR TO S/N 250904

1000 HOUR KIT

PART NUMBER: 75124815

<u>QUANTITY</u>	<u>PART NUMBER</u>	<u>DESCRIPTION</u>
1	10263460	ENGINE OIL DRAIN GASKET
2	04630787	LUBE OIL FILTER
1	73118171	TRANSMISSION FILTER
1	04788503	FILTER - FUEL
1	71004848	TRANSMISSION GASKET STRAINER
1	70924166	O'RING HYDRAULIC FILTER
1	79026104	STEERING FILTER
1	79032087	HYDRAULIC OIL FILTER
1	73119796	AIR FILTER - PRIMARY
1	73119796	AIR FILTER - SAFETY

NOTE: Clean and reuse:

Fuel inlet strainer - 00700314

Transmission suction strainer - 71004849

"FILTER CARE" KIT
 MODEL: FD7 - S/N 250905 & UP
 IVECO ENGINE

250 HOUR KIT

PART NUMBER: 75127721

QUANTITY	PART NUMBER	DESCRIPTION
2	04630787	ENGINE OIL FILTER
1	10263460	ENGINE OIL PLUG SEAL

"FILTER CARE" KIT
 MODEL: FD7 - S/N 250905 & UP

500 HOUR KIT

PART NUMBER: 75127106

QUANTITY	PART NUMBER	DESCRIPTION
1	10263460	ENGINE OIL DRAIN GASKET
2	04630787	LUBE OIL FILTER
1	73118171	TRANSMISSION FILTER
2	04795601	FUEL FILTER
1	71004848	TRANSMISSION GASKET STRAINER
1	70924166	O'RING HYDRAULIC FILTER
1	79026104	STEERING FILTER
1	79032087	HYDRAULIC OIL FILTER

NOTE: Clean and reuse:
 Fuel inlet strainer.
 Transmission suction strainer - 71004849

"FILTER CARE" KIT
 MODEL: FD7 - S/N 250905 & UP

1000 HOUR KIT

PART NUMBER: 75127107

QUANTITY	PART NUMBER	DESCRIPTION
1	10263460	ENGINE OIL DRAIN GASKET
2	04630787	LUBE OIL FILTER
1	73118171	TRANSMISSION FILTER
2	04795601	FUEL FILTER
1	71004848	TRANSMISSION GASKET STRAINER
1	70924166	O'RING HYDRAULIC FILTER
1	79026104	STEERING FILTER
1	79032087	HYDRAULIC OIL FILTER
1	73119795	AIR FILTER - PRIMARY
1	73119796	AIR FILTER - SAFETY

NOTE: Clean and reuse:
 Fuel inlet strainer.
 Transmission suction strainer - 71004849

PAINTING AND MARKING

ITEM	PART NO.	QTY.	DESCRIPTION	ITEM	PART NO.	QTY.	DESCRIPTION
-	73153575	-	KIT, DECAL INCLUDES ITEMS 3-10,12,14-16,27	15	73107893	2	DECAL, TRACK RELEASE SPRING
-	76009643	-	KIT, DECAL INCLUDES ITEMS 3,11,13,17-26,28-31	16	79016937	1	DECAL, STEERING CLUTCH SPRING
1	73127995	-	PAINT, 12 PZ. SPRAY CAN	17	-----	1	DECAL, "ROPS"
2	73127996	-	PAINT, GAL. CAN	18	79012691	1	DECAL, LIFTING POINTS
3	79024918	1	DECAL, LUBE & SERVICE GUIDE	19	79089476	1	PLATE, THROTTLE CONTROL
4	73107895	1	DECAL, "DO NOT START"	20	79018891	1	DECAL, IMPLEMENT CONTROL
5	73108799	1	DECAL, OPERATION	21	79028482	1	DECAL, FRONT-REAR IMPL.
6	79012804	1	DECAL, STARTUP, SHUTDOWN	22	79019898	2	DECAL, TRANS. LOCKING LEVER
7	73107891	1	DECAL, MASTER SWITCH	23	79028476	1	DECAL, IMPLEMENT LOCKING
8	73107881	2	DECAL, BLADES & BELTS	24	79060535	1	DECAL, ENGINE STARTING INSTR.
9	73107897	2	DECAL, INOPERATIVE BRAKES	25	79060540	2	DECAL, KEEP CLEAR
10	73107890	4	DECAL, SCISSORS POINT	26	79073482	1	DECAL, EXPLOSIVE GASES
11	73109131	1	DECAL, INSTRUCTION MANUAL	27	73109097	1	TAG, COOLING SYSTEM
12	73107882	2	DECAL, FLAMMABLE VAPORS	28	79019360	1	PLATE, TRANSMISSION RANGE
13	73107884	1	DECAL, FLUID PRESSURE	29	79059803	1	PLATE, TRANSMISSION DIRECTION
14	73108929	2	DECAL, TRACK TENSION	30	76004006	1	DECAL, HYDRAULIC TANK
				31	73108722	2	DECAL, FLAMMABLE FLUID

NUMERICAL INDEX - INDICE DELLE PARTI DE RICAMBIO - INDEX DES PIECES DETACHEES - ERSATZTEIL-VERZEICHNIS - INDICE DE PIEZAS DE REPUESTO

00000000..	A243	12646921..	L304(1)	73108440..	L601/1	79035976..	L601/1
00992699..	F301	13279811..	F401(1)	73108441..	L601/1	79036917..	B408(2)
04990239..	F301	13609711..	L601/1	73108444..	F629(1)	79037299..	F401(1)
04994336..	F301	13974530..	B408(2)	73110484..	A243	79037301..	F401(4)
04995683..	F301	14142490..	F401(1)	73115559..	A243	79037302..	F401(1)
10405485..	F401(1)	15896218..	F301	73115562..	A243	79042811..	F401(1)
10441590..	F401(1)	15977931..	L304(1)	73115563..	A243	79042812..	F401(1)
10449890..	F401(4)	15989331..	L304(1)	73115565..	A243	79042813..	F401(1)
10450090..	F401(4)	15996037..	B408(1)	73115987..	A243	79042823..	F401(1)
10450290..	F401(4)	16043031..	F401(4)	73115988..	A243	79043274..	F401(1)
10450790..	F401(4)	16043431..	L304(1)	73121194..	A243	79045870..	L304(1)
10516571..	L601/1	16043621..	L601/1	73122739..	F501(2)	79045873..	L304(1)
10516871..	L601/1	16100818..	F301	73132158..	A243	80913744..	F401(1)
10517071..	F401(4)	45015482..	L304(1)	73138198..	F401(1)		
10517171..	L304(1)	70609217..	A243	73138199..	F401(4)		
10517271..	L304(1)	70621821..	F629(1)	73143763..	A243		
10517471..	L304(1)	70639388..	A243	76000905..	F401(1)		
10520221..	L304(1)	70669359..	A243	79009243..	B408(2)		
10571571..	F401(1)	70677004..	F501(2)	19006370..	F401(1)		
10571771..	F401(4)	70677006..	L601/1	19011643..	F401(1)		
10571871..	A243	70697138..	F629(1)	79011645..	F401(1)		
10571971..	L304(1)	70897460..	F301	79111647..	F401(1)		
10902430..	F501(2)	70910287..	L601/1	79111649..	F401(1)		
10979331..	F401(4)	70910510..	F629(1)	79013422..	F401(4)		
11092090..	F401(1)	70911026..	L601/1	79016720..	L304(1)		
11103031..	L304(1)	70911114..	A243	79017173..	F401(4)		
11105231..	L601/1	70911327..	A243	79023861..	F401(4)		
11107421..	A243	70911841..	A243	79024936..	L304(1)		
11112431..	L304(1)	70912589..	A243	79026974..	L304(1)		
11112531..	L304(1)	70912731..	F629(1)	79027389..	L304(1)		
11113231..	L304(1)	70913744..	F401(4)	79027296..	L304(1)		
11118731..	L304(1)	70920651..	L601/1	79027338..	L304(1)		
11701711..	A243	70921076..	L601/1	79031355..	F401(4)		
11701731..	F401(4)	70926192..	F401(1)	79032280..	F401(4)		
11945018..	F301	70928138..	A243	79032598..	F401(1)		
11947708..	F301	70932747..	A243	79033501..	L304(1)		
12164327..	B408(2)	73092086..	A243	79033502..	L304(1)		
12644320..	L304(1)	73070169..	A243	79034924..	L304(1)		
12644721..	L304(1)	73075858..	L601/1	79034527..	L304(1)		
12646821..	A243	73108117..	F629(1)	79035208..	F301		

LATE ADDITIONS 12/90

73066401	A408(1)
73108722	5
73169097	5
73153575	5
73155767	A408(1)
73156287	D229(2)
73160023	D340/A(1)
73299688	D340/A(1)
73299689	D340/A(1)
73299690	F401(3A)
73299694	F401(3A)
73299697	F401(3A)
73299714	F401(3A)
73299715	F401(3A)
73299716	F401(3A)
74364809	A408(1)
75004008	5
76009543	5
76012691	5
79012204	5
79018891	5
79018360	5
79019899	5
79024916	5
79027918	C101(1)
79027939	C101(1)
79028476	5
79028482	5
79028483	5
79028484	5
79028485	5

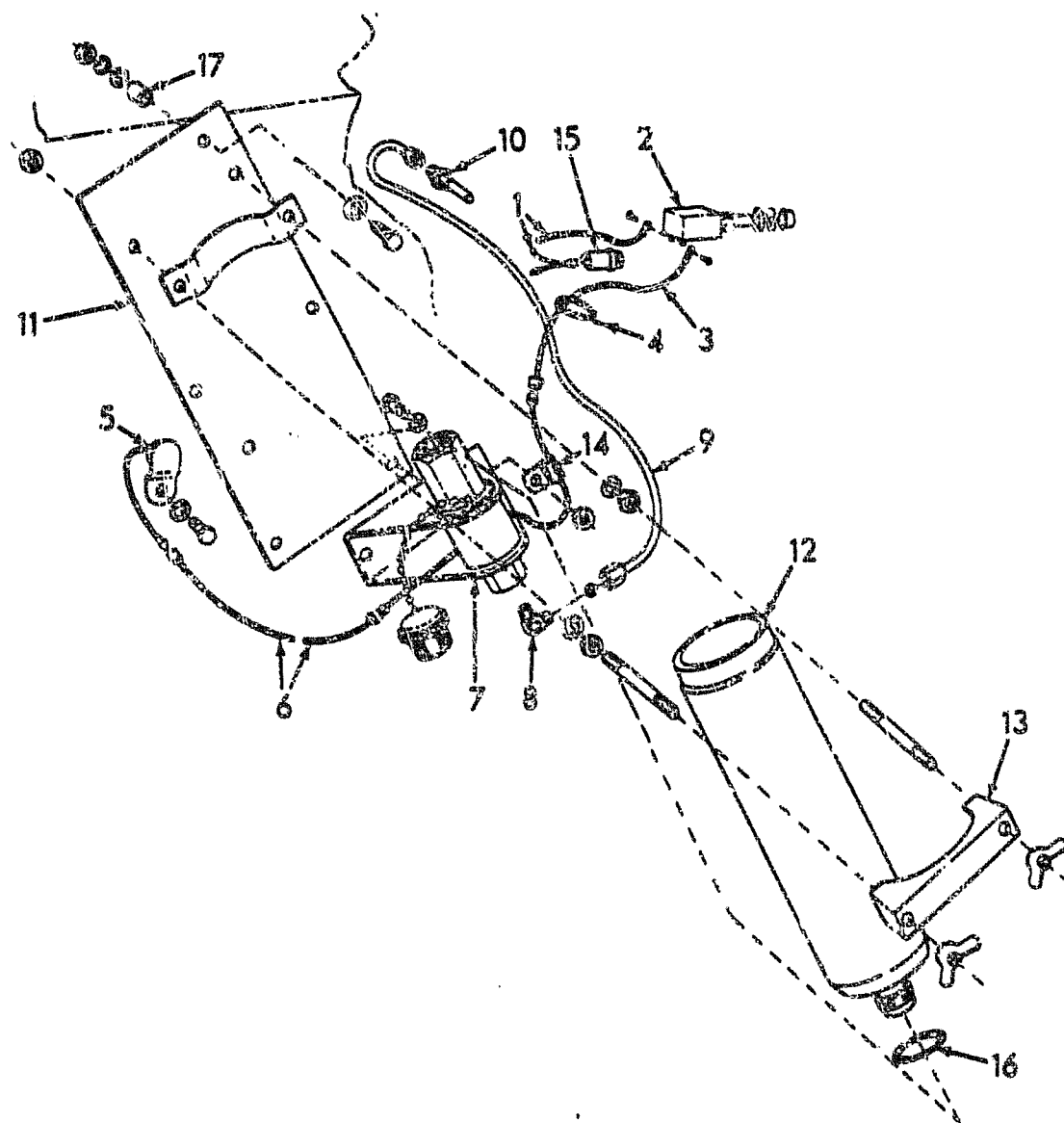

T82310

ITEM	PART NO.	QTY.	LEX.	DESCRIPTION	DENOMINAZIONE
1	73143763	1	105F	CABLE	FUNE
2	73115559	1	751	SWITCH (INCLUDES BOOT)	INTERRUTTORE
3	73115562	1	105F	CABLE	FUNE
4	70932747	6	501H	TIE	TIRANTE
			600P	AS REQUIRED	DEFINITO AL MONTAGGIO
5	73115560	1	500F	THERMOGUARD	SCUDO TERMICO
6	73115567	1	105F	CABLE	FUNE
7	73115563	1	10V	VALVE	VALVOLA
	70928138	2	40V	CAPSCREW, 1/4"NC X 5/8"	VITE
	70911114	4	131R	WASHER	ROSETTA
	70911327	2	100	NUT, 1/4"NC	DADO
8	73052086	1	85G	ELBOW	GOMITO
9	73110484	1	200T	TUBE	TUBO
	70911841	2	301A	SLEEVE, COMPRESSION, 1/4"	MANICOTTO COMPRESSIONE
	70912589	2	100	NUT, 1/4"	DADO
10	73115565	1	500E	ATOMIZER	POLVERIZZATORE
11	73121194	1	80M	BRACKET	MENSOLA
	11107421	2	40V	CAPSCREW	VITE
	12646821	4	131R	WASHER	ROSETTA
	10571871	2	132R	LOCKWASHER, M8	ROSETTA DI SICUREZZA
	11701711	2	100	NUT, M10 X 1.25	DADO
12	73132158	1	164C	CYLINDER	CILINDRO
			600L	INCLUDES ITEM(S) 16	INCLUDE PARTIC. (1)
13	70669359	1	120M	CLAMP	MORSETTO COLLARE
			600R	INCL. HARDWARE	INCL. VITERIA
14	70639388	1	84G	CLIP	GRAFFETTA
15	-----	1	168P	HOLDER, FUSE	PORTAFUSIBILE
16	73070169	1	123G	GASKET	GUARNIZIONE DI TENUTA
17	70609217	2	73D	SPACER	DISTANZIALE

FD7

COLD WEATHER START
 DISPOSITIVO PER AVVIAMENTO A BASSA TEMPERATURA
 DEMARRAGE PAR TEMPS FROID
 KALTWETTERSTART
 ACESORIO DE ARRANQUE POR TIEMPO FRIO

N7

A243

ITEM PART NO. QTY. LEX. DESCRIPTION

1	74394509	1	106H	ELEMENT, HEATING (120V)
2	73155767	1	1C5F	CABLE (120V)
3	73059401	1	35S	HOUSING

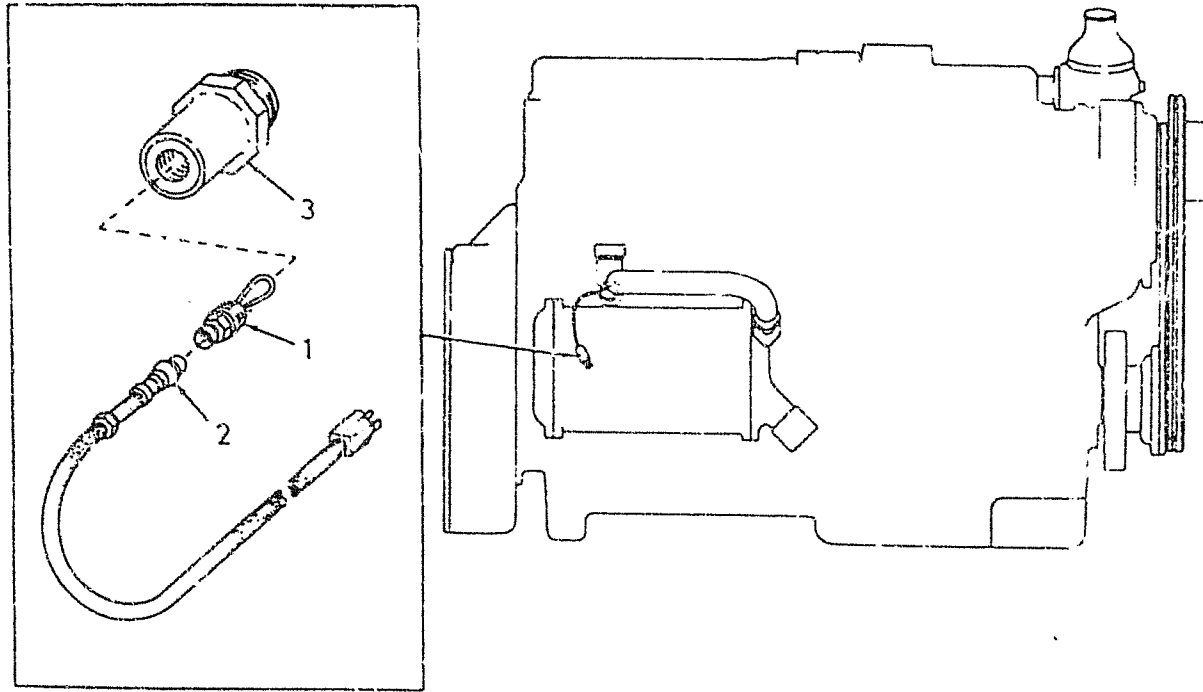

FD7

ENGINE COOLANT HEATER

A405

1

ADDED NOVEMBER 1990

N8

B408(2)

ITEM	PART NO.	QTY.	LEX.	DESCRIPTION	DENOMINAZIONE
1	12164327	4	100	NUT, 20 X 1,5 X 16	DADO
2	13974530	4	210P	STUD, 20 X 1,5 X 160	FRIGIONIERO
3	79005243	4	131R	WASHER	ROSETTA
4	75036917	1	62T	COUNTERWEIGHT	CONTRAPPESO
			600H	REAR	POSTERIORE
	15996037	4	40V	CAPSCREW	VITE

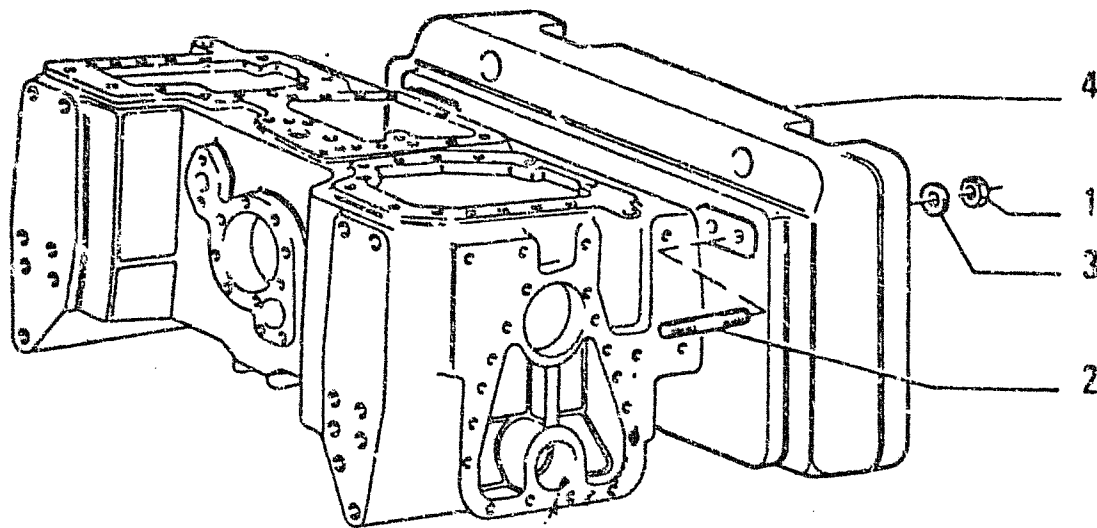

FD7	COUNTERWEIGHT	B408	2
N9			

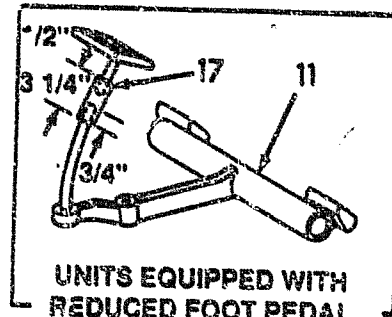

UNITS EQUIPPED WITH
REDUCED FOOT PEDAL
EFFORT REFER TO S. D. 184

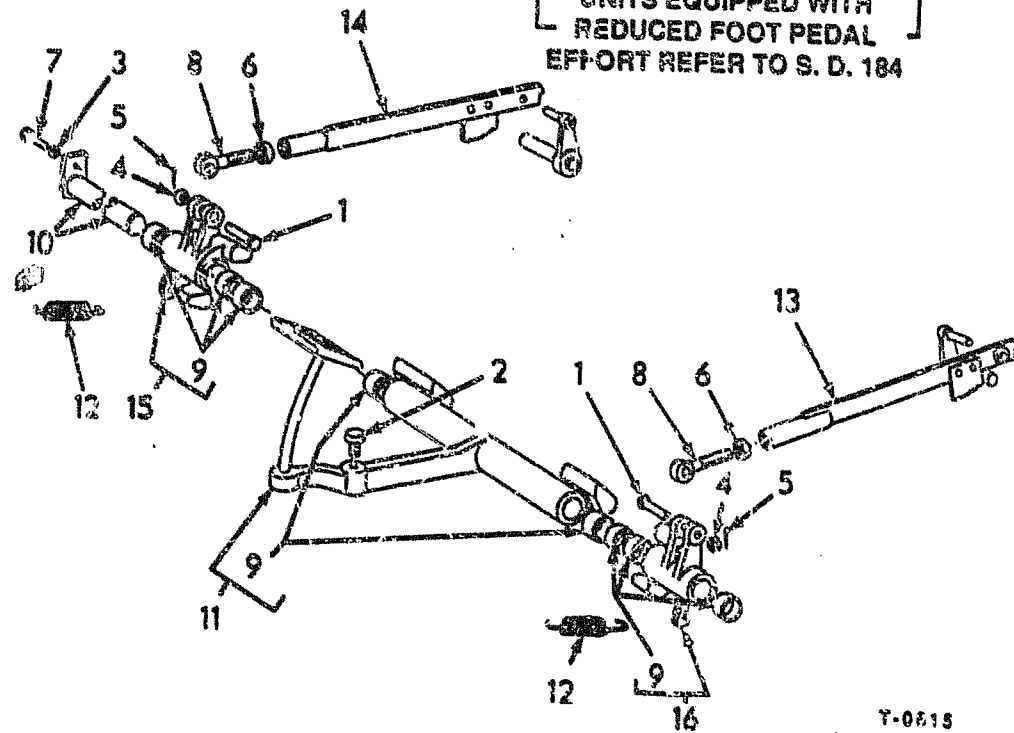

T-0815

ITEM PART NO. QTY. LEX. DESCRIPTION

ITEM	PART NO.	QTY.	LEX.	DESCRIPTION
1	00584009	2	80P	PIN
2	00591420	1	61T	PAD, CUSHIONING
3	10516671	1	132R	LOCKWASHER, 8.1X2.2
4	10520101	2	131R	WASHER, 14.4X26
5	10734601	2	270C	PIN, SPLIT, 2.7X37.6
6	10791321	2	10D	NUT, 14X1.5X8
7	16043631	1	40V	CAPSCREW, 8X1.25X25
8	79003622	2	62E	HEAD, TIEROD
9	79004903	8	95B	BUSHING
10	79012399	1	16A	SHAFT
11	79024586	1	60P	PEDAL
12	79026134	2	100M	SPRING
13	79027110	1	142T	TIEROD, LEFT
14	79027126	1	142T	TIEROD, RIGHT
15	79027916	1	135M	HUB RIGHT
16	79027938	1	135M	HUB LEFT
17	-----	1	206T	TUBE, 5/8" I.D. X 7/8" O.D.

USAGE: UNITS WITH FOOT CONTROLLED STEERING AND REDUCED FOOT
PEDAL EFFORT.

FD7

BRAKE CONTROL

C101

1

ADDED NOVEMBER 1930

N10

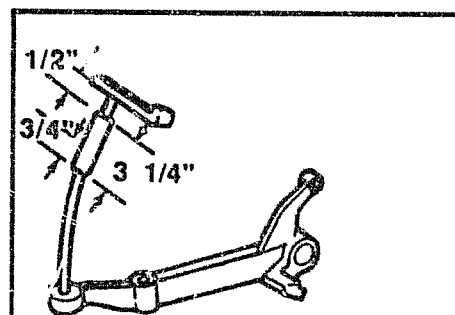
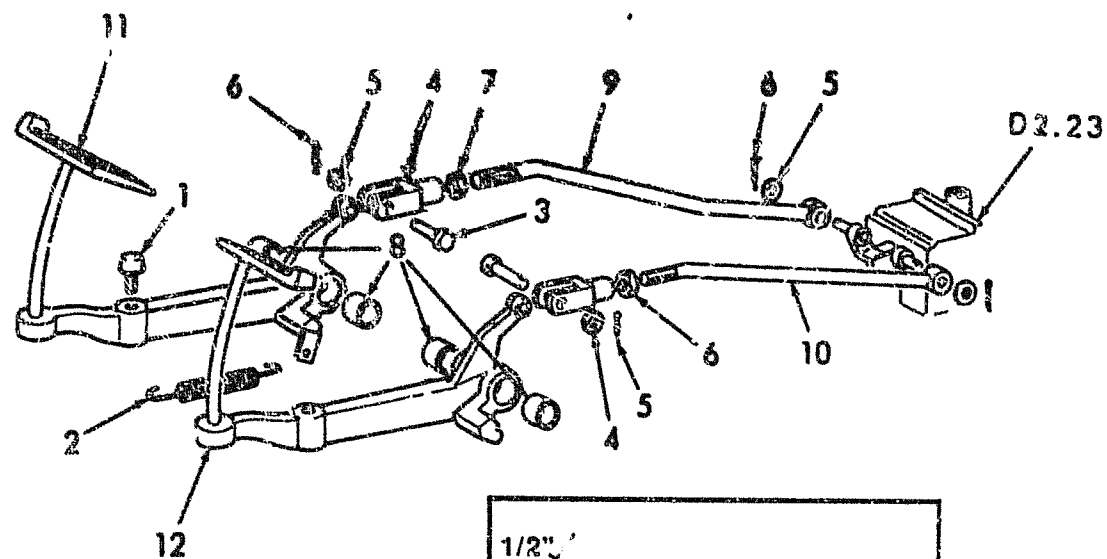

UNITS EQUIPPED WITH
REDUCED FOOT PEDAL
EFFORT (REFER TO SD184)

T-0817

USAGE: UNITS WITH FOOT CONTROLLED STEERING AND REDUCED FOOT
PEDAL EFFORT.

ITEM PART NO. QTY. LEX. DESCRIPTION

ITEM	PART NO.	QTY.	LEX.	DESCRIPTION
1	00591420	2	61T	PAD, CUSHIONING
2	04987835	2	100M	SPRING
3	10005010	2	80P	PIN
4	10248471	2	86F	YOKE
5	10520021	4	131R	WASHER
6	10733601	4	270C	PIN, SPLIT
7	10791221	2	10D	NUT
8	79004903	4	95B	BUSHING
9	79026823	1	141T	TIEROD, THREADED-RIGHT
10	79026825	1	141T	TIEROD, THREADED-LEFT
11	79025109	1	60P	PEDAL-RIGHT
			600L	INCL ITEM 8
12	79025111	1	60P	PEDAL-LEFT
			600L	INCL ITEM 8
13	-----	2	206T	TUBE, 5/8" I.D., 7/8" O.D.
			600T	REQUIRES WELDING

FD7

STEERING CLUTCH CONTROL

D222

1

ADDED NOVEMBER 1990

N11

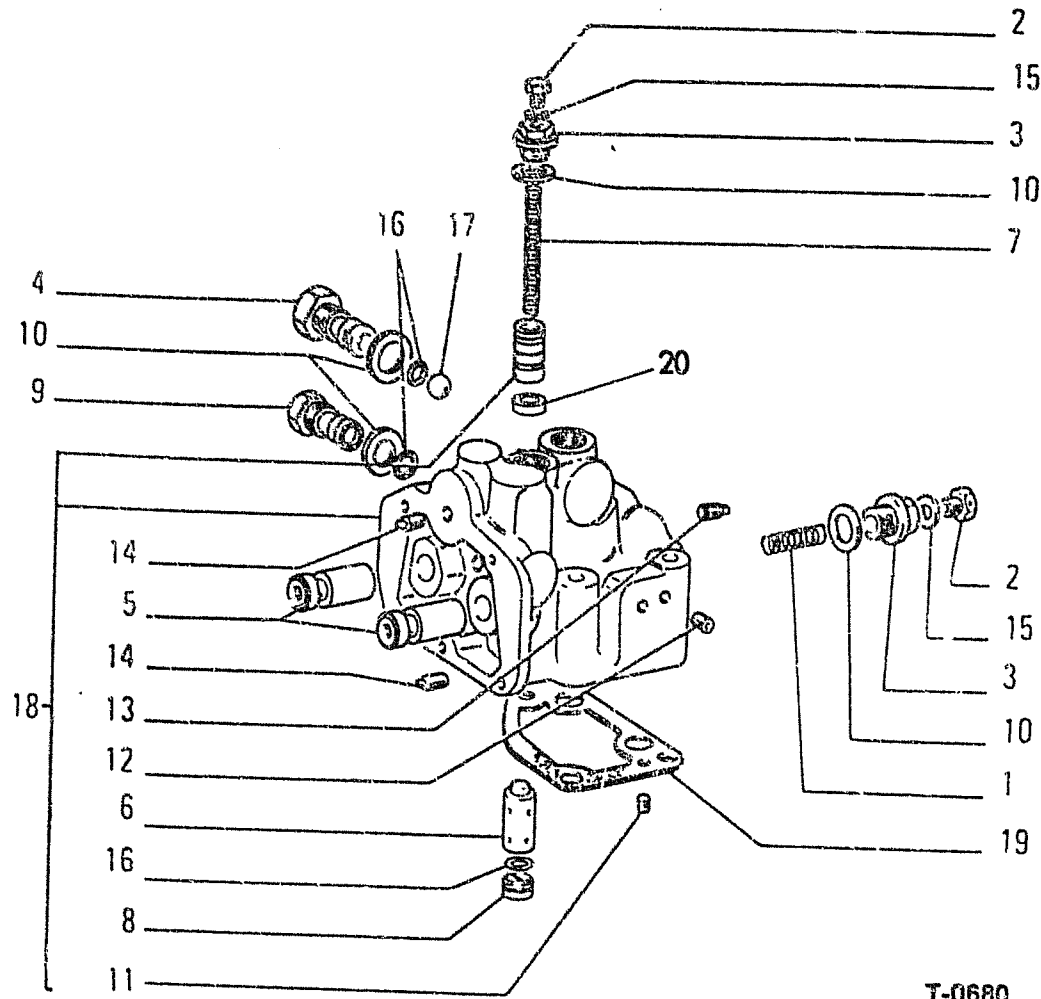

T-0680

ITEM PART NO. QTY. LEX. DESCRIPTION

ITEM	PART NO.	QTY.	LEX.	DESCRIPTION
1	00575874	2	100M	SPRING
2	00581658	3	50T	PLUG
3	00581967	3	90B	UNION
4	00587158	1	50T	PLUG
5	00591105	2	75F	CARRIER
6	00591108	1	75F	CARRIER
7	79036901	1	100M	SPRING
8	00591247	1	50T	PLUG LOWER
9	00595878	1	50T	PLUG
10	10257460	5	133R	SEAL, 20.2X26
11	10269450	1	50T	PLUG, 12X1.5X11
12	14324811	2	50T	PLUG, 12X1.5X13
13	14324911	2	50T	PLUG, 14X1.5X13
14	14325011	2	50T	PLUG, 16X1.5X13
15	14330260	3	133R	SEAL, 8.2X12
16	14456980	3	55A	C-RING, 2.62X10.77
17	20063000	1	140S	BALL, 15.082
18	79002971	1	300C	BODY
19	79007717	1	123G	GASKET
20	79034828	1	75D	SPACER

USAGE: UNITS WITH IMPROVED STEERING.

FD7

CONTROL VALVE

D229

1

ADDED NOVEMBER 1990

N12

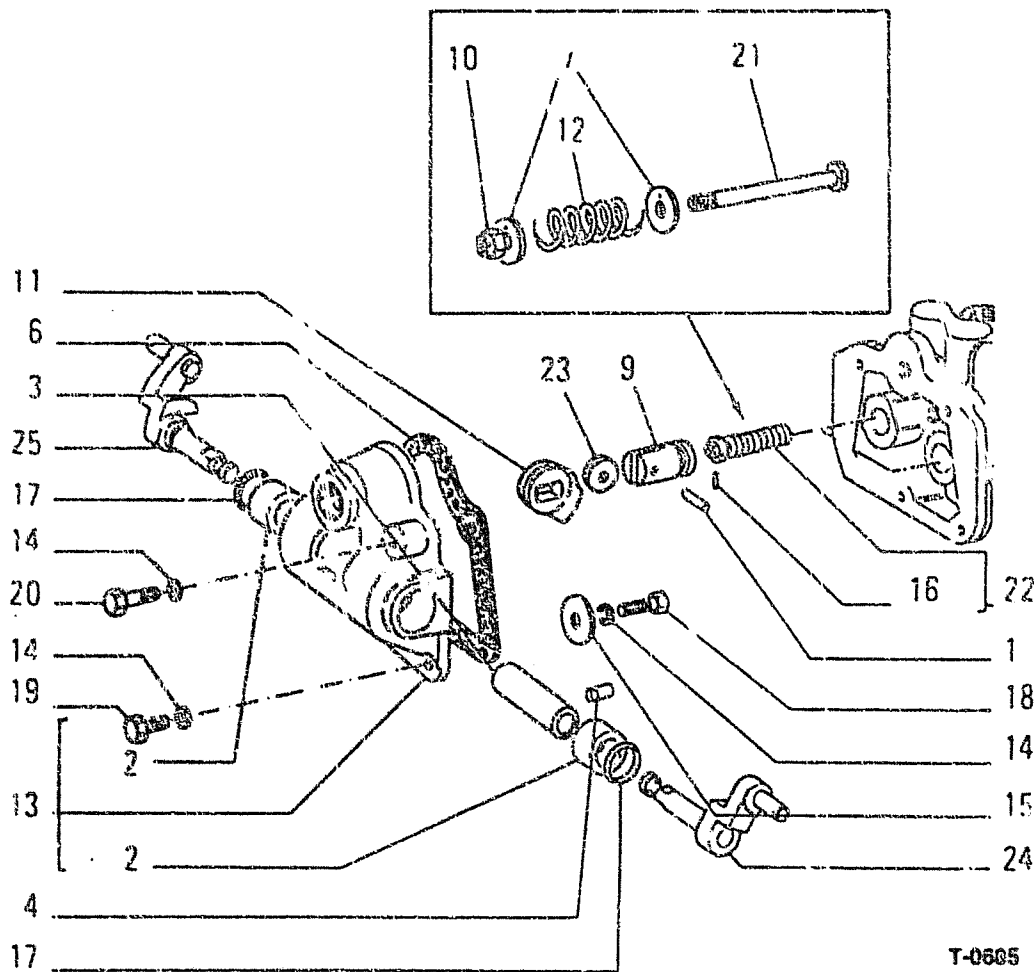

ITEM - PART NO. QTY. LEX. DESCRIPTION

1	00578868	2	80P	PIN
2	00587138	2	95B	RUSHING
3	00587141	1	75D	SPACER
4	00587142	2	80P	PIN
6	00591115	1	123G	GASKET
7	00591121	4	131R	WASHER
9	00595736	2	240P	TAPPET
10	00599820	2	10D	NUT
11	04951759	2	10E	ECCENTRIC
12	73156287	2	100M	SPRING OUTER
13	04983643	1	265C	COVER
14	10516671	6	132R	LOCKWASHER, 8.1X2.2
15	12647001	1	131R	WASHER, 8.15X25
16	14157470	2	80P	PIN, 1.7X10
17	14457280	2	55A	O-RING, 2.62X15.54
18	16043131	1	40V	CAPSCREW, 8X1.25X14
19	16043431	3	40V	CAPSCREW, 8X1.25X20
20	16043931	2	40V	CAPSCREW, 8X1.25X35
21	79003679	2	80P	PIN
22	79003686	2	100M	SPRING
23	79004493	2	157R	ROLLER
24	79025170	1	45L	LEVER OUTER
25	79025172	1	45L	LEVER OUTER

USAGE: UNITS WITH IMPROVED STEERING.

FD7

CONTROL VALVE

N13

D229

2

ADDED NOVEMBER 1990

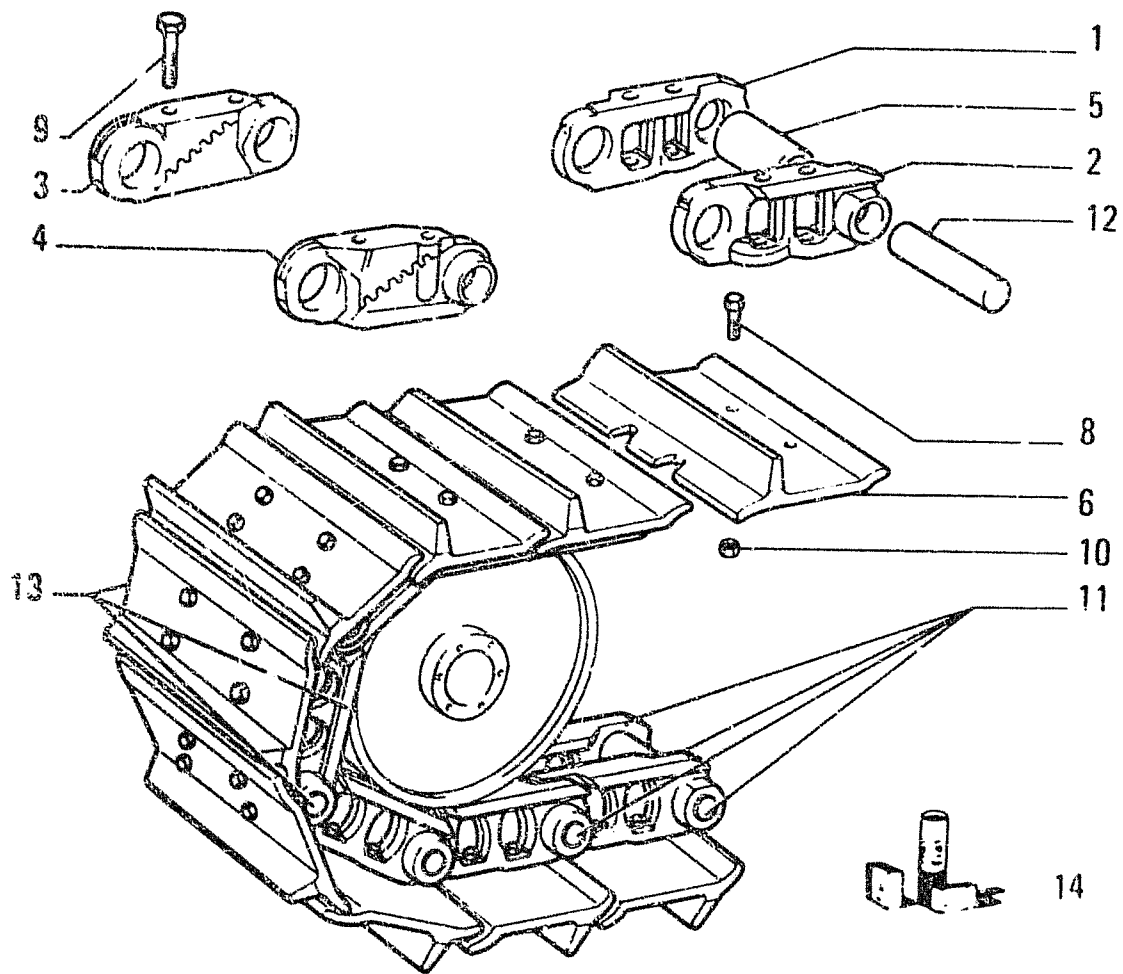

ITEM PART NO. QTY. LEX. DESCRIPTION

1	79086895	37	145M	TRACK LINK-RIGHT
2	79086894	37	145M	TRACK LINK-LEFT
3	79086896	1	145M	TRACK LINK-RIGHT
4	79086897	1	145M	TRACK LINK-LEFT
5	79089109	38	95B	BUSHING
6	79026832	38	295S	SHOE (450MM)
	79026835	38	295S	SHOE (500MM)(43MM GROUSER)
	73160023	38	295S	SHOE (500MM)(53MM GROUSER)
	73299688	38	295S	SHOE (500MM CUT-OUT) (LEFT)
	73299689	38	295S	SHOE (500MM CUT-OUT) (RIGHT)
8	76008353	148	40V	SCREW
9	76015201	2	40V	SCREW (55MM)
	76015987	2	40V	SCREW (85MM)
10	76008354	148	10D	NUT
11	79080081	2	97C	TRACK CHAIN - ASSEMBLY
12	79089110	38	80P	PIN
13	76015787	2	97C	TRACK CHAIN - ASSEMBLY (450MM)
	76015788	2	97C	TRACK CHAIN - ASSEMBLY (500MM)
14	76015040	2	1K	KIT SEE PAGE 9 (500MM)
	76015041	2	1K	KIT SEE PAGE 9 (450MM)

USAGE: UNIT S/N 251326 AND UP

FD7	TRACK	D340/A	1
ADDED NOVEMBER 1990			

N14

F301

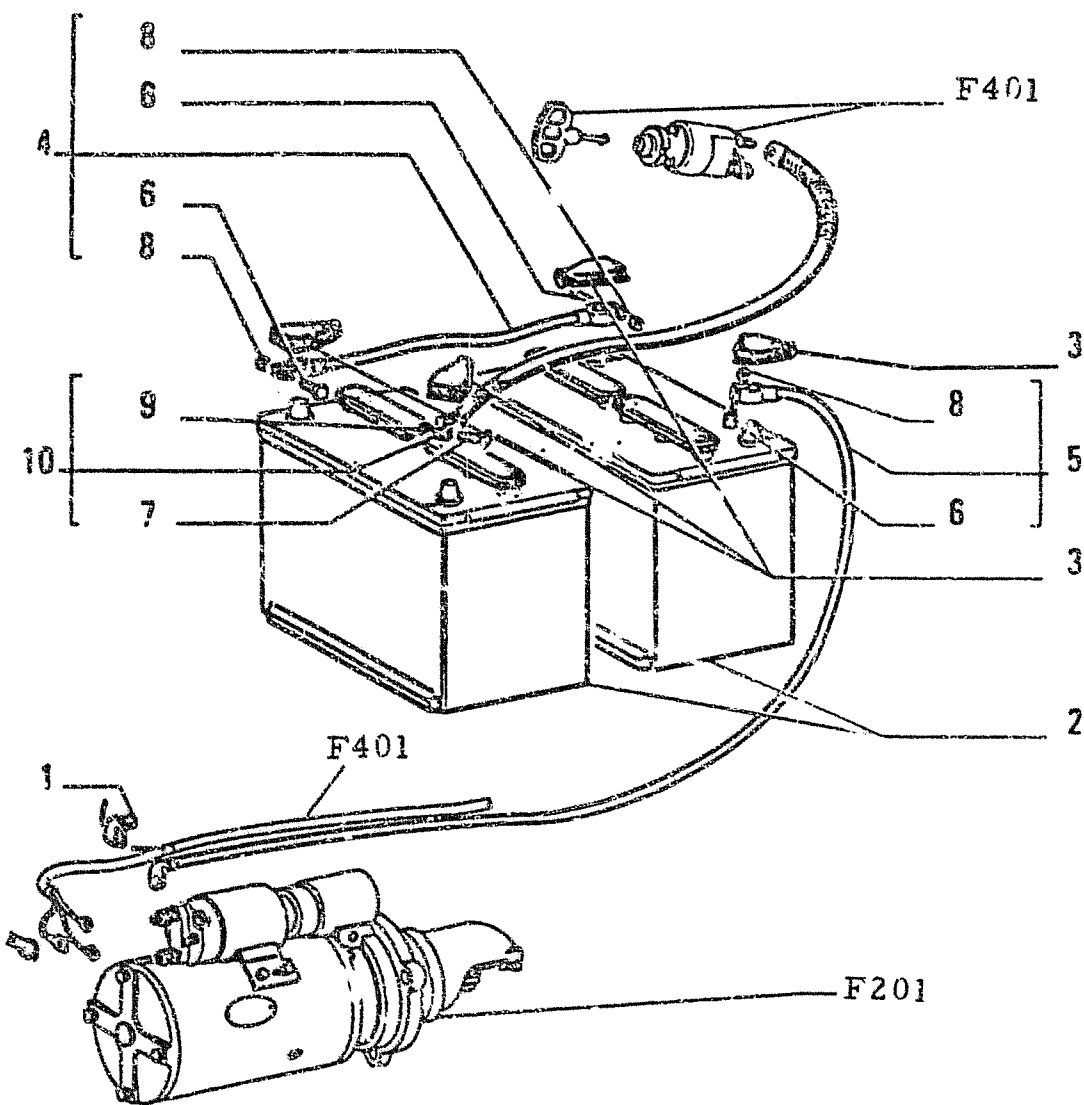

ITEM	PART NO.	QTY.	LEX.	DESCRIPTION	DENOMINAZIONE
1	00552699	1	65C	BOOT, INSULATING	CAPPUCCIO ISOLANTE
2	70697460	2	25B	BATTERY	BATTERIA
3	04950259	3	65C	BOOT, INSULATING	CAPPUCCIO ISOLANTE
4	04954336	1	111C	CABLE, ELECTRIC	CAVO ELETTRICO
5	04995683	1	111C	CABLE, ELECTRIC	CAVO ELETTRICO
6	11945008	3	40V	CAPSCREW, 6 X 1 X 30	VITE
7	11947708	1	40V	CAPSCREW, 8 X 1.25 X 30	VITE
8	15896218	3	10D	NUT, 6 X 1 X 5	DADO
9	16100818	1	10D	NUT, 8 X 1.25 X 6.5	DADO
10	79035908	1	166T	BRAID, GROUND	TRECCIA DI MASSA

FD7	BATTERIES & CABLES BATTERIE E CAVI ACCUS ET CABLES BATTERIEN UND KABEL BATERIAS Y CABLES	F301	

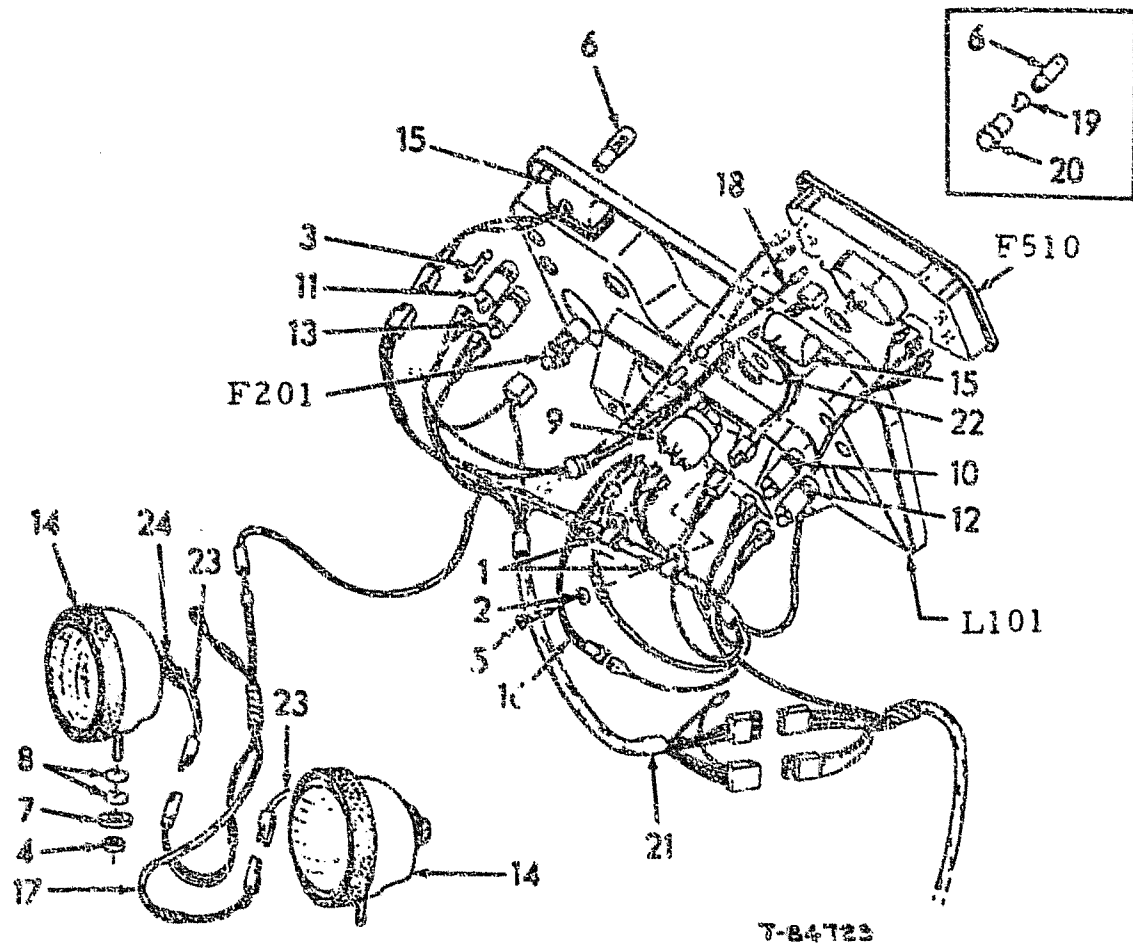

ITEM PART NO. QTY. LEX. DESCRIPTION

1	10441590	2	89G	C LIP
2	10571571	2	132R	LOCKWASHER, 6.1X1.6
3	11052090	4	110F	FUSE 6 X 25
4	70913744	4	10D	NUT, 1/2"
5	13275811	2	40V	CAPSCREW, 6 X 1 X 8
6	14142490	10	30L	BULB, 9.15X8.8
7	70926192	2	131R	WASHER
8	76000905	4	74B	BLOCK
9	79006370	1	75I	SWITCH
10	79011643	1	188P	HOLDER, FUSE
11	79011645	1	188P	HOLDER, FUSE
12	79011647	1	188P	HOLDER, FUSE
13	79011649	1	188P	HOLDER, FUSE
14	-----	2	220P	HEADLAMP (F629(1))
15	79032398	2	12F	LAMP, INSTRUMENT
16	79037299	1	111C	CABLE, ELECTRIC
17	79037302	1	111C	CABLE, ELECTRIC
			600G	FRONT
18	79042811	1	111C	CABLE, ELECTRIC
19	79042812	8	60C	TERMINAL, WIRE
20	79042813	8	193P	HOLDER, BULB
21	79042823	1	111C	CABLE, ELECTRIC
22	79043274	1	8D	DECAL
23	73138198	2	111C	CABLE, ELECTRIC
24	10405485	2	330C	BOOT

FD7

LIGHTS & WIRING

F401

1

REVISED NOVEMBER 1990

N16

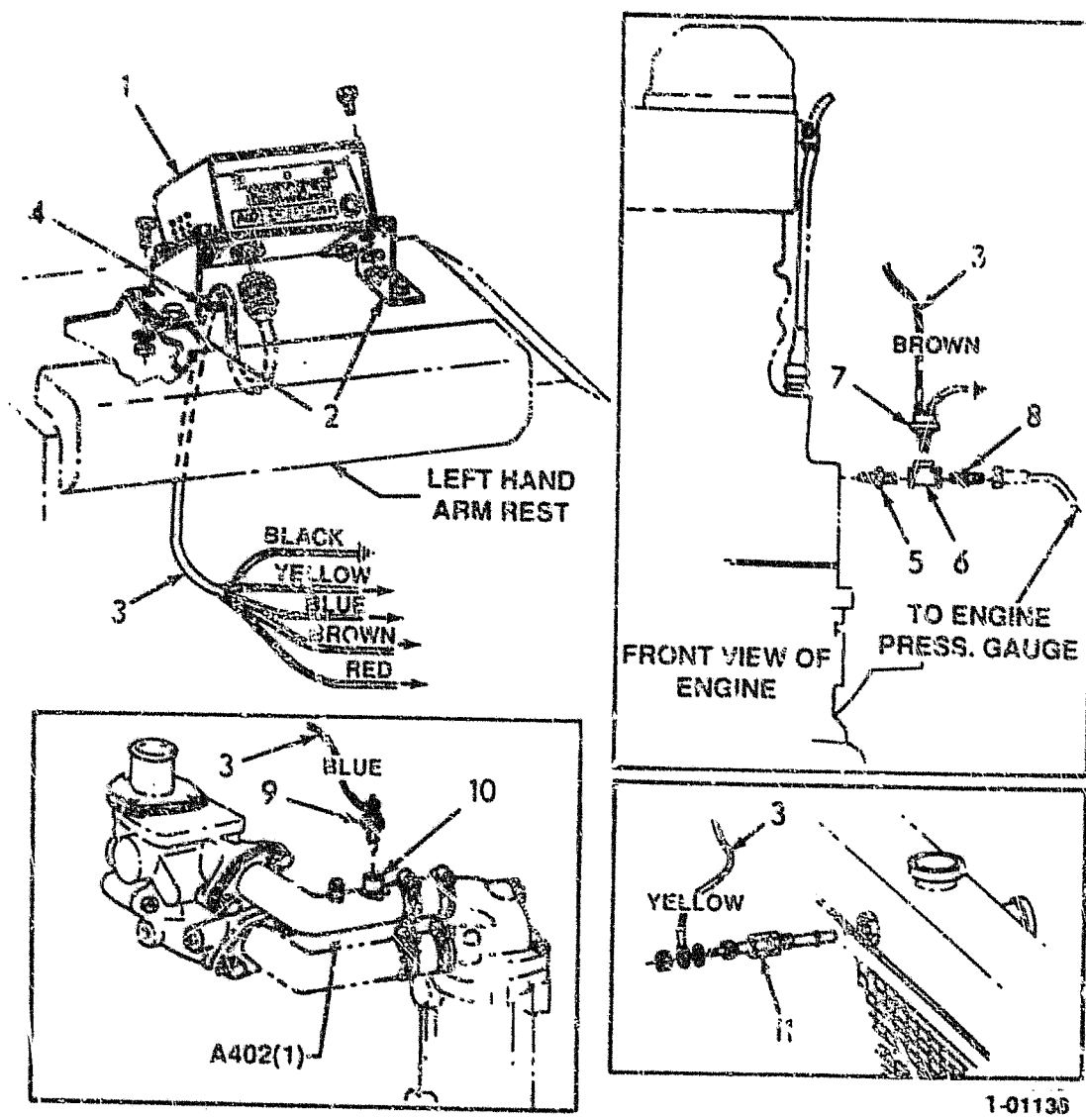

ITEM PART NO. QTY. LEX. DESCRIPTION

1	73299714	1	501R	ALARM KIT
			500L	INCLS. ITEMS 3,7
	70927541	4	40V	CAPSCREW, 1/4"NCX3/4"
	70677004	4	131R	WASHER
	70911024	4	10D	NUT, 1/4"NC
2	73299715	1	80M	BRACKET, RIGHT
	73299716	1	80M	BRACKET, LEFT
	70927541	4	40V	CAPSCREW, 1/4"NCX3/4"
	70677004	4	131R	WASHER
	70911024	4	10D	NUT, 1/4"NC
3	-----	1	70I	CABLE, HARNESS
	70928628	4	60C	TERMINAL, #10
	70934663	2	60C	TERMINAL, 3/8"
4	70913233	1	500J	GROMMET
5	73299693	1	75B	CONNECTOR
6	70901702	1	16R	TEE
7	-----	1	160T	SENDING, UNIT, ENGINE OIL PRESSURE
8	73299694	1	75B	CONNECTOR
9	-----	1	160T	SENDING, UNIT, COOLANT TEMPERATURE
10	73299697	1	20R	FITTING
			600T	REQUIRES WELDING
11	-----	1	160T	SENDING, UNIT, COOLANT LEVEL

USAGE: SPECIAL EQUIPMENT

FD7

ALARM INDICATING DEVICE

F401

3A

N17

ADDED NOVEMBER 1990

DESIGNAZIONE BASE	BASIC DESIGNATION	DESIGNATIONS-BASES	GRUNDBEZEICHNUNGEN	DENOMINACIONES BASE	
286C	COPPIA DI INGRANAGGI	GEAR SET	COUPLE D'ENGRENA- GES	ZAHNRAUPAAR	PAR DE ENGRANAJES
286C					
286T	TELAIO ANTERIORE	FRONT MAIN FRAME	CHASSIS AVANT	RAHMEN VORN	ARMAZON DELANTERO
287T	TELAIO POSTERIORE	REAR MAIN FRAME	CHASSIS ARRIERE	RAHMEN HINTER	ARMAZON TRASERO
288S	STRUMENTO MULTIPLO	INSTRUMENT CLUSTER	COMBINE DE BORD PLUS INDICAT	KOMBINSTRUMENT	CUADRO DE INDICACIONES MULTIPLO
288T	TROMBA ACUSTICA	PROJECTOR	TROMPETTE	TROMPETE	TROMPETA
289T	TRATTORE	TRACTOR	TRACTEUR	MASCHINE	TRACTOR
29G1	COMANDI ESTERNI CAMBIO	TRANSMISSION OUTSIDE CONTROL	COMMANDES EXTER. BOITE V TESSE	AEUSSERE GETRIEBESCHALTUNG	VARRILAJE CAMBIO VELOCIDADES
29G2	COMANDI ESTERNI RIDUTTORE	LOW SPEED OUTER CONTROLS	COMMANDES EXTER. REDUCTEUR	ZUSATZGETRIEBESCHALTUNG	MANCO DEL REDUCTOR DEL CAMBIO
29G3	DISPOSITIVI SICUREZZA CAMBIO	TRANSMISSION SAFETY DEVICE	BLOCAGE DE BOITE DE VITESSES	GETRIEBESCHALTSPERRE	ENCLAVAMIENTO DEL CAMBIO
29C0C	COPRIGIUNTO	FISHPLATE	COUVRE-JOINT	LASCHE	CUBREJUNTAS
290T	TUBETTO IDENTIFIC. CAVI	CABLE IDENTIF. TUBE			
291C	COPRIGUARNIZIONE	SEAL COVER	COUVRE-JOINT	HAUTER	ABRIZADERA
291T	TORQUE CONTROL	TORQUE CONTROL			
292C	COPRIPEDALE DI GOMMA	PEDAL RUBBER PAD	GARNITURE CADUTCHOU	FUSSHEBELUEBERZUG	FORRO DE CAUCHO
293C	COPRITAPPO	PLUG COVER	CACHE-BOUCHON	SCHUTZKAPPE	CAPUCHON
294S	SUCCHIERUOLA	SUCTION ROSE	CREPINE	SAUGSIEB	FILTRO DE ASPIRACION
295C	CORNICE	BEZEL	MONTURE	RAHMEN	MARCO
295S	SUOLA	SHOE	PATIN	KETTENPLATTE	ZAPATA
296C	COPRIPULSANTE	BUTTON COVER	CACHE-BOUTON	DRUCKKNOPFDECKEL	CAPUCHA
297C	CORONA DENTATA	RING GEAR	COURONNE DENTEE	ZAHNKRANZ	CORONA DENTADA
29A2	CILINDRO POSIZIONATORE	POSITIONER CYLINDER	CYLINDRE POSITION	STELLZYLINDER	
3044	CILINDRO PENETRAZIONE	PENETRATION CYLINDER	CYLINDRE DE PENETRATION	EINDRINGZYLINDER	
300C	CORPO	BODY	CORPS	GEHAUSE	CUERPO
300S	SUPPORTO	SUPPORT	SUPPORT	TRAEGER	SOPORTE
3007	PNEUMATICI 23.5X25	TIRES 23.5X25	PNEUS 23.5X25	REIFEN 23.5X25	
301S	SUPPORTO ELASTICO	SNLBBER	SUPPORT ELASTIQUE	FEDERTRAEGER	APOYO ELASTICO
3017	PNEUMATICI 20X24	TIRES 20X24		REIFEN 20X24	
302S	SUPPORTO OSCILLANTE	SWIVELLING BLOCK	SUPPORT OSCILLANT	KIPPLAGER	APOYO OSCILANTE
304S	SUPPORTO MASSE CENTRIFUGHE	WEIGHT PLATE	PLAQUE DE MASSE- LOTTE	VERSTELI PLATTE	SOPORTE DEL CON- TRAPESO
304S					
305S	SUPPORTO CON CATADIOTTRO	SUPPORT W/REFLEX REFLECTOR	SUPPORT AVEC CATA- DIOPTR	LAGER MIT RUECK- STRAHLER	SOPORTE CON CATA- FAROS
305S					
307C	CORRETTORE	CORRECTOR	CORPECTEUR	VERSTELLER	CORRECTOR
308C	CORRETTORE DI FRENO	BRAKE COMPENSATOR	REPARTITEUR DE FRENAGE	BREMSVERSTELLER	CORRECTOR DE FRENADO
308C					
310S	SUPPRESSORE FRENI	BRAKE BOOSTER	SURPRESSEUR DE FRENE	DRUCKVERSTELLER	REFORZADOR DE FRENO
312C	CREMAGLIERA	RACK	CREMAILLIERE	ZAHNSTANGE	CREMALLERA
315C	CRISTALLO	GLASS PANE	GLACE	GLASSSCHEIBE	CRISTAL
316C	CRISTALLO PROIETTORE	HEADLAMP LENS	GLACE DE PRO- JECTEUR	STREUSCHEIBE	CRISTAL DE PRO- JECTOR
316C					

DESIGNAZIONE BASE	BASIC DESIGNATION	DESIGNATIONS-BASES	GRUNDBEZEICHNUNGEN	DENOMINACIONES BASE
238P	PUNTALE	PUSH ROD	EMBOUT	HERRETE
238P	PUNTELLO	STAY	BEQUILLE	PUNTAL
246A	TURAZIONI TRASMISSIONI STATICA	HYDROSTATIC DRIVE SYSTEM LINES		
240P	PUNTERIA	TAPPET	POUSSOIR	PERNIO ARTICOLATO
241P	PUNTERIA A RULLO	ROLLER TAPPET	POUSSOIR A GALET	EMPUJADOR DE RODILLO
242P	PUNTA DENTE RIPPER	RIPPER SHANK POINT	POINTE DENT SCARIFICATEUR	PUJA DE DIENTE RIPPER
244P	PUNZONE	STRUT	ETAI	LISTON
245C	CONTACHILOMETRI	SPEEDOMETER KM	COMPTEUR KILOMETRIQUE	CUENTAKILOMETROS
245C				
245C	CONTAMIGLIA	SPEEDOMETER-MILES	COMPTEUR DE MILLES	CUENTAMILLAS
247C	CONTAGIRI	TACHOMETER	COMPTE-TOURS	CUENTAREVOLUCIONES
248C	CONTACRE	HOURMETER	HOROMETRE	CUENTAHORAS
248P	PUNZONE	PUNCH	POINCON	PUNZON
256A	INNESTO TRASMISSIONE	ENGINE/TRANSMISSION COUPLING		
2561	COLLEGAMENTO CAMBIO	TRANSMISSION CONNECTING	CONNECTIONS DE BOITE VITESSES	
250C	CONTATTO	CONTACT	CONTACT	CONTACTO
254C	CONTENITORE	CONTAINER	CONTAINEUR	RECIPIENTE
255C	CONTENITORE FILTRO	FILTER SHELL	CUVE DE FILTRE	CAMISA DE FILTRO
257C	CONTRODADO	LOCK NUT	CONTRE-ECROU	CONTRATUERCA
259C	CONVERTITTORE DI COPPIA	TORQUE CONVERTER	CONVERTISSEUR DE COUPLE	CONVERTIDOR
260C	CONVOGLIATORE	SHROUD	CONVOYEUR	CANALIZADOR
265C	COVERCHIO	COVER	COUVERCLE	CAPA
270C	COPIGLIA	COTTER PIN	COUPLIN	CHAVETA PARTIDA
271S	STATORE	STATOR	STATOR	ESTATOR
274C	COPPA OLIO	OIL SUMP	CARTER A HUILE	CARTER DE ACEITE
274S	STELO	ROD	TIGE	VASTAGO
275C	COPPA	SUMP	CARTER A HUILE	CARTER DE ACEITE
275S	STERZO	STEERING	DIRECTION	DIRECCION
278C	COPPA DELLA RUOTA	WHEEL CAP	ENJOLIVEUR DE ROUE	EMBELECEDOR DE RUEDA
278C				
279C	COPPA RACCOGLIOLIO	OIL SHIELD	COLLECTEUR D'HUILE	RETENEDOR DE ACEITE
279C				
286B	DISPOSITIVO LUBRIFIC CAMBIO	TRANS LUBRICATION SYSTEM	DISP LUBRIFIC BOITE VITESSE	
280S	STOPPINO	WICK	MECHE	MECHA
282T	TARGA MANUTENZIONE	SERVICE AND LUBE INSTRUCTION	DECALCOMANIE ENTRETIEN	CALCOMANIA DE MANTENIMIENTO
283T	TARGETTA IDENTIFICAZIONE	IDENTIFICATION PLATE	PLAQUETTE RECAPITULATIVE	PLAQUETA DE IDENTIFICACION
284T	TERGICRISTALLO POSTERIORE	WINDSCREEN WIPER	ESSUIE-GLACE	LIMPIA-CRISTAL POST
285C	COPPIA CONICA	BEVEL GEAR SET	COUPLE CONIQUE	PAR CONICO
285T	TUBO FLESSIBILE	HOSE	TUYAU FLEXIBLE	TUBO FLEXIBLE

DESIGNAZIONE BASE	BASIC DESIGNATION	DESIGNATIONS-BASES	GRUNDBEZEICHNUNGEN	DENDOMINACIONES BASE
210C	COMMUTATORE	SWITCH	COMMUTATEUR	COMMUTADOR
210P	PIGIONIERO	STUD	GOUJON	ESPARRAGO
210T	TURBOCOMPRESSORE	TURBOCHARGER	TURBOCOMPRESSEUR	TURBOCOMPRESOR
211T	TUTA	OVERALL	COMBINAISON	MONO DE MECANICO
214C	COMPRENDE	INCLUDES...	COMPREND ...	COMPRENDE...
215P	PROFILATO	CHANNEL	PROFILE	PERFIL
215S	SQUADRETTA	CONNECTING PLATE	EQUERRE	ESCUADRA
216C	COMPRESSORE ARIA	AIR COMPRESSOR	COMPRESSEUR D'AIR	COMPRESOR
216P	PROFILATO DI GOMMA	RUBBER SECTION	PROFILE CAOUTCHOUC	PERFIL DE GOMA
218P	PROIETTORE A TRE LUCI	THREE-LIGHT HEADLAMP	PROJECTEUR A TROIS FEUX	PROYECTOR DE TRES LUCES
218P			ROTATION PELLE RETRO	ROTACION RETROEXCAVADORA
220D	ROTAZIONE RETROSCAVATORE	BACKHOE ROTATION	CONDENSATEUR	CONDENSADOR
220C	CONDENSATORE	CONDENSER	PROJECTEUR	PROYECTOR
220P	PROIETTORE	FLOODLIGHT	STABILISATEUR	ESTABILIZADOR
220S	STABILIZZATORE	STABILIZER	CLIMATISEUR	CLIMATIZADOR
221C	CONDIZIONATORE	AIR CONDITIONER	PROJECTEUR JUMELÉ	PROYECTORES GEME- LOS
221P	PROIETTORE SDOPPIATO	DUAL HEADLAMP		EXTENSION
221P			RALLONGE	CONDUCTO
222P	PROLUNGA	EXTENSION	CONDUIT	EXTENSION DE MAN- GUERA
223C	CONDOTTO	DUCT	RALLONGE DE GOM- FLAGE	
223P	PROLUNGA PER GONFIAGGIO	TIRE INFLATION EXTENSION	CONDUIT D'AIR	CONDUCTO DE AIRE
223P			PROTECTION	DEFENSA
223P			CONDUIT D'ADMISSION	COLECTOR DE ASPIRACION
224C	CONDOTTO ARIA	AIR DUCT	ETRIER	ESTRIBO
224P	PROTEZIONE	SHIELD	ETRIER PROFILE	BRIDA DE SECCION
225C	COLLETTORF ASPIRAZIONE	INTAKE MANIFOLD	EN U	EN U
225S	STAFFA	BRACKET		
226S	STAFFA AD U	U-BOLT		
226S				
23G3	PEDALIERA	PEDAL CONTROL	CONDUIT D'ECHAPPEMENT	COLECTOR DE ESCAPE
23G5	TUBAZIONI COMANDO TRASMISSIONE	TRANSMISSION CONTROL LINES	POULIE	POLEA
230C	COLLETTORE DI SCARICO	EXHAUST MANIFOLD	VOLTAMPEROMETRE	VOLTAMPERIMETRO
230P	PULEGGIA	POULIE	COLLIER	ABRAZADERA
230V	VOLTAMPEROMETRO	VOLTAMPERE METER	PEINTURE	TINTURA
231S	STAFFETTA	CLIP	CONNECTION	CONEXION
231V	VERNICE	PAINT	PISTON	EMBOLO
235C	CONNESSIONE	CONNECTION	PUSH BUTTON	PULSADOR
235S	STANTUFFO	PISTON	SWITCH PANEL	DECLADO
236P	PULSANTE	PUSH BUTTON		
237P	PULSANIERA	SWITCH PANEL		

NORTH AMERICA VERSION ONLY
VERSIONE SOLO PER NORD AMERICA

The attached pages are an addition to the machine's parts catalog.
These additional items are not covered in the main parts catalog but are in this supplement.

Le pagine che seguono sono una aggiunta al catalogo base di questo modello.
Le parti elencate in questa sezione non sono comprese negli elenchi ed indici del catalogo principale, ma soltanto in questa sezione supplementare.

Les pages ci après sont un additif au catalogue de base de ce modèle.
Les pièces énumérées dans cette section ne figurent pas dans les listes et dans les index du catalogue principal, mais seulement dans cette section supplémentaire.

Die folgenden Seiten sind ein Nachtrag zum Hauptkatalog dieses Modells.
Die in diesem Abschnitt angeführten Teile sind nicht in den Listen und Verzeichnissen des Hauptkatalogs, sondern nur in diesem Nachtrag enthalten.

Las páginas que van a continuación constituyen un apéndice del catálogo básico de este modelo. Las piezas aquí reseñadas no salen en las listas e índices del catálogo principal, sino tan solo en este suplemento.

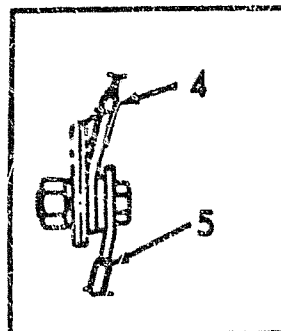
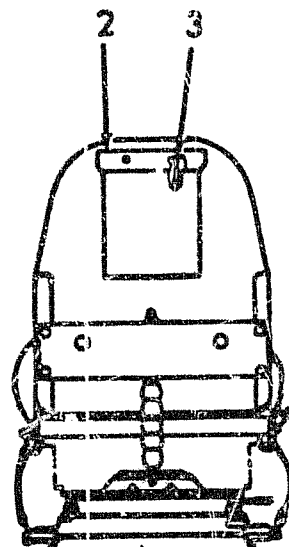
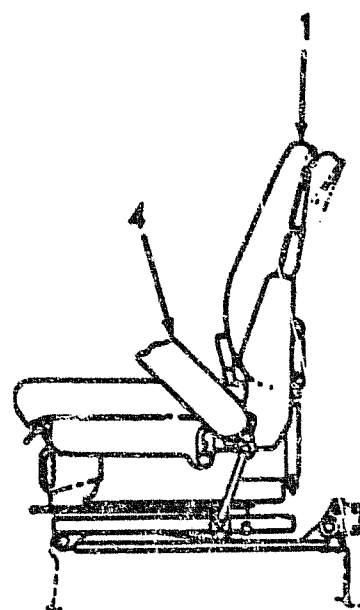

7-84705

ITEM	PART NO.	QTY.	LEX.	DESCRIPTION	DETERMINAZIONE
1	-----	1	80S	SEAT(L604)	
	16043621	4	40V	CAPSCREW, M8 X 1,25 X 25MM	VITE
	10516671	4	131R	WASHER	ROSETTA
	13605711	4	75D	SPACER	DISTANZIALE
2	73108441	1	501L	POCKET	SACCA
	70920651	2	42V	SCREW,#8 X 1/2"	VITE
3	73108440	1	95C	CHAIN	CATENA
4	73075858	1	182C	SEAT BELT	CINTURA DI SICUREZZA
	70921076	2	40V	CAPSCREW	VITE
	70677006	2	131R	WASHER	ROSETTA
	70910287	2	132R	LOCKWASHER	ROSETTA DI SICUREZZA
	70911026	2	10D	NUT	DADO
5	79035976	2		TETHER	
	11106231	2	40V	CAPSCREW, M10 X 1,5 X 25MM	VITE
	10516871	2	132R	LOCKWASHER	ROSETTA DI SICUREZZA
	70677006	2	131R	WASHER	ROSETTA

FD7

SEAT
SEDILE
SIEGE
SITZ
ASIENTO

L601/1

ITEM	PART NO.	QTY.	LEV.	DESCRIPTION	DENOMINAZIONE
29	79045870	1	115G	GUARD	PROTEZIONE
			600G	FRONT	ANTERIORE
			600B	RIGHT	DESTRO
	79045873	1	115G	GUARD	PROTEZIONE
			600G	FRONT	ANTERIORE
			600A	LEFT	SINISTRO
30	45015482	2	502D	STEP /READ	PEDANA ANTISORUCCIOLO

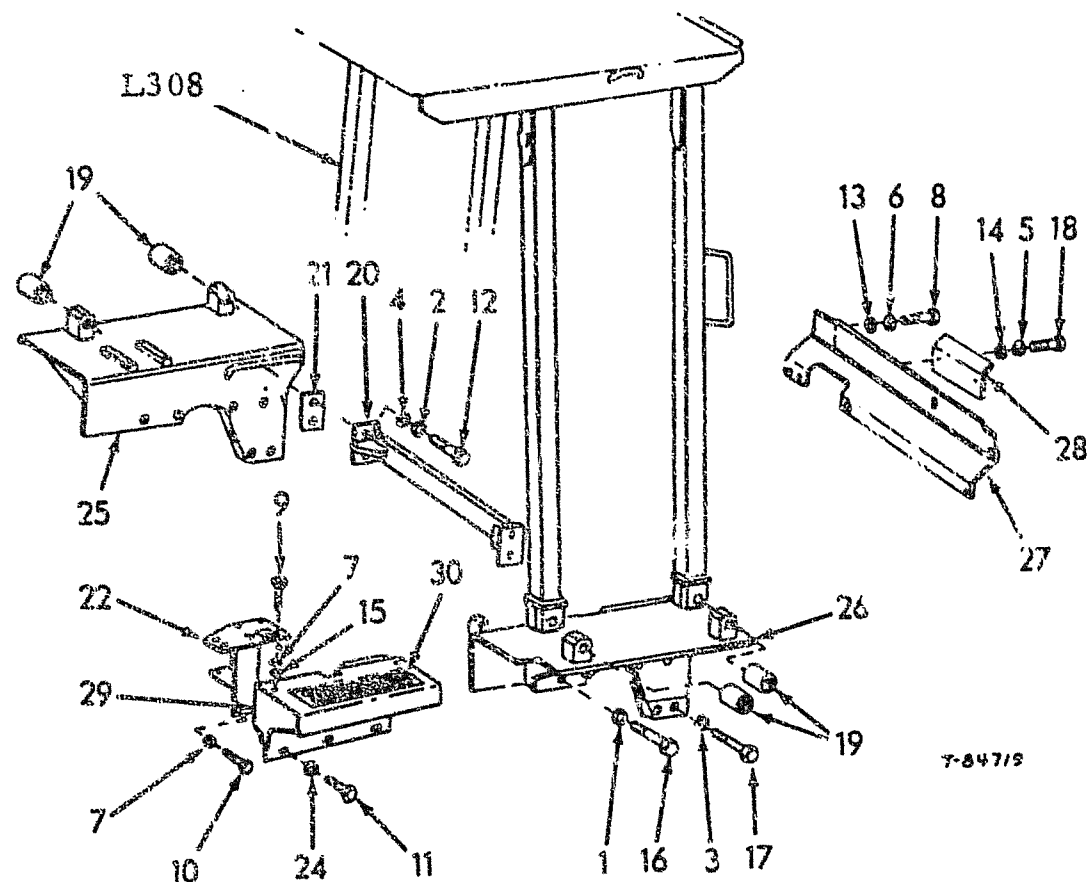

FD7

LADDER, HANDRAIL & FENDERS
 SCALA MANCORRENTI E PARAFANGHI
 ECHELLE, MAINS COURANTES ET GARDE-BOUE
 LEITER, HANDGRIFF UND SCHUTZBLECHE
 ESCALER, SARANDILLA Y GUARDABARROS

L304

1

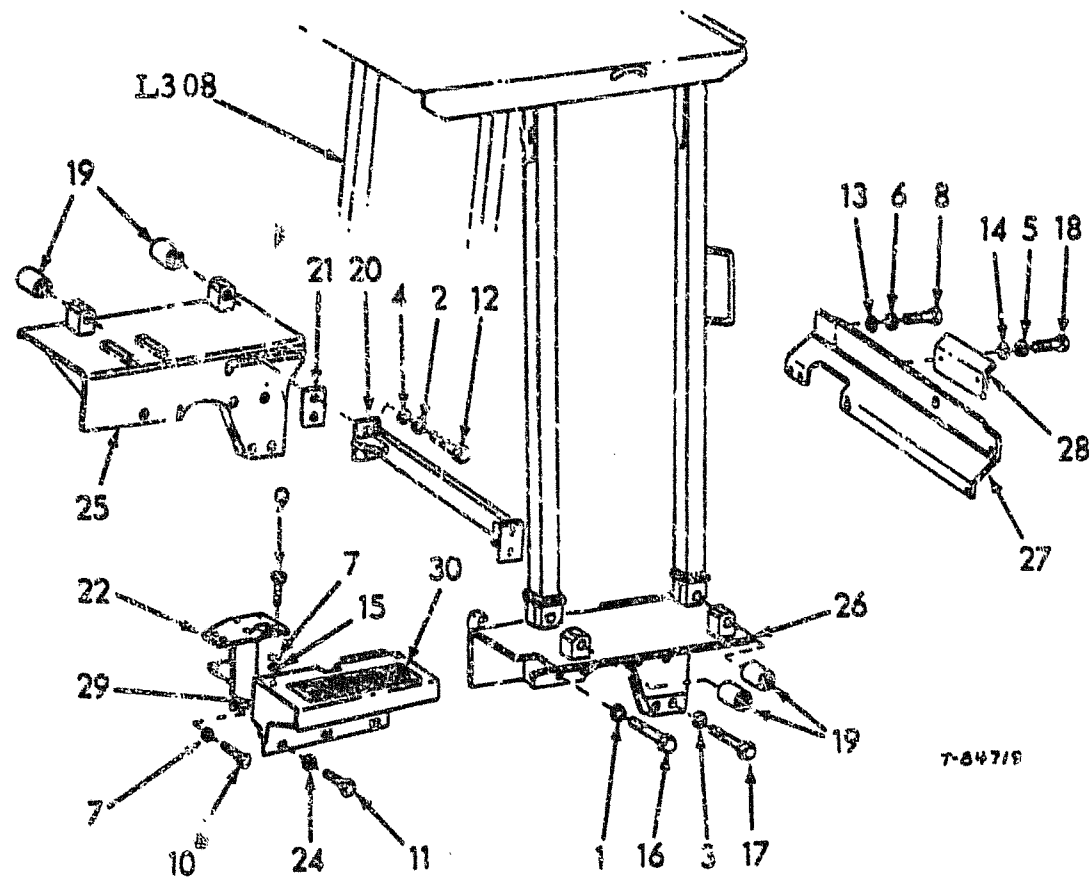

ITEM	PART NO.	QTY.	LEX.	DESCRIPTION	DENOMINAZIONE
1	10517171	4	132R	LOCKWASHER, 14.2 X 3.3	ROSETTA DI SICUREZZA
2	10517271	4	132R	LOCKWASHER, 16.2 X 4	ROSETTA DI SICUREZZA
3	10517471	8	132R	LOCKWASHER, 20.2 X 4.9	ROSETTA DI SICUREZZA
4	10520221	4	131R	WASHER, 16.4 X 26	ROSETTA
5	10571771	2	132R	LOCKWASHER, 8.1 X 2	ROSETTA DI SICUREZZA
6	10571871	4	132R	LOCKWASHER, 10.2 X 2.2	ROSETTA DI SICUREZZA
7	10571971	12	132R	LOCKWASHER, 12.2 X 2.9	ROSETTA DI SICUREZZA
8	11103031	4	40V	CAPSCREW, 10 X 1.5 X 16	VITE
9	11112431	4	40V	CAPSCREW, 12 X 1.75 X 30	VITE
10	11112831	8	40V	CAPSCREW, 12 X 1.75 X 40	VITE
11	11113231	8	40V	CAPSCREW, 12 X 1.75 X 50	VITE
12	11118731	4	40V	CAPSCREW, 16 X 2 X 40	VITE
13	12644320	4	131R	WASHER, 10.2 X 33	ROSETTA
14	12646721	2	131R	WASHER, 8.15 X 20	ROSETTA
15	12646921	4	131R	WASHER, 12.2 X 28	ROSETTA
16	15977931	4	40V	CAPSCREW, 14 X 1.5 X 90	VITE
17	15989331	8	40V	CAPSCREW, 20 X 1.5 X 110	VITE
18	16043431	2	40V	CAPSCREW, 8 X 1.25 X 20	VITE
19	79048203	4	95B	BUSHING	BUCIOLA
20	79026936	1	5020	BEAM	TRAVE
			600H	REAR	POSTERIORE
21	79026974	-	1985	SHIM, ADJUSTMENT	SPESSORE DI REGISTRO
			600P	AS REQUIRED	DEFINITO AL MONTAGGIO
22	79027289	1	300S	SUPPORT	SUPPORTO
	79027296	1	300S	SUPPORT	SUPPORTO
24	79027338	6	131R	WASHER	ROSETTA
25	79048258	1	115G	GUARD	PROTEZIONE
			600H	REAR	POSTERIORE
			600B	RIGHT	DESTRO
26	79048259	1	115G	GUARD	PROTEZIONE
			600H	REAR	POSTERIORE
			600A	LEFT	SINISTRO
27	79034524	1	165P	PLATE	PIASTRA
			600H	REAR	POSTERIORE
28	79034526	1	265C	COVER	COPERCHIO

FD7

LADDER, HANDRAIL & FENDERS
 SCALA MANCORRENTI E PARAFANGHI
 ECHELLE, MAINS COURANTES ET GARDE-BOUE
 LEITER, HANDGRIFF UND SCHUTZBLECHE
 ESCALER, BARANDILLA Y GUARDABARROS

L304

1

Revised November 1990

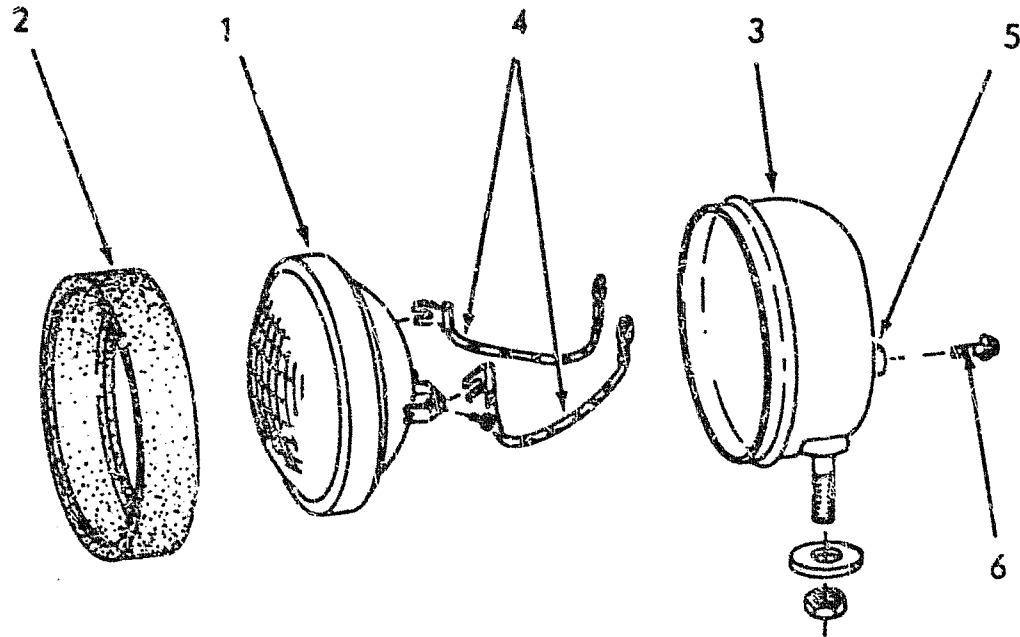

ITEM	PART NO.	QTY.	LEX.	DESCRIPTION	DENOMINAZIONE
-	70697138	2	116G	LIGHT ASSY.	GRUPPO OTTICO
			600P	INCLUDES ITEM(S) 1-6	INCLUDE PARTIC. (1)
1	73108117	1	9P	LAMP	FANALE
2	70621821	1	61S	RETAINER	SCODELLINO DI RITEGNO
3	-----	1	5V	SHELL	VALVA
			601C	NOT SERVICED	NON FORNITO DI RICAMB.
	70926192	1	131R	WASHER	ROSETTA
	70910510	1	10D	NUT, 1/2"NC	DADO
4	73108444	2	60F	WIRE	FILO
5	-----	1	75B	CONNECTOR	BLOCCETTO CONNESSIONE
			601C	NOT SERVICED	NON FORNITO DI RICAMB.
6	70912731	2	42V	SCREW, #8-32NC X 5/16"	VITE

T-80980

FD7	HEAD LIGHT LUCI PHARES SCHEINWERFER FAROS DELANTEROS	F629	1

F501(2)

ITEM	PART NO.	QTY.	LEX.	DESCRIPTION	DENOMINAZIONE
1	73122739	1	105A	HORN	AVVISATORE
	10902430	5	40V	CAPSCREW	VITE
	70677004	6	131R	WASHER	ROSETTA

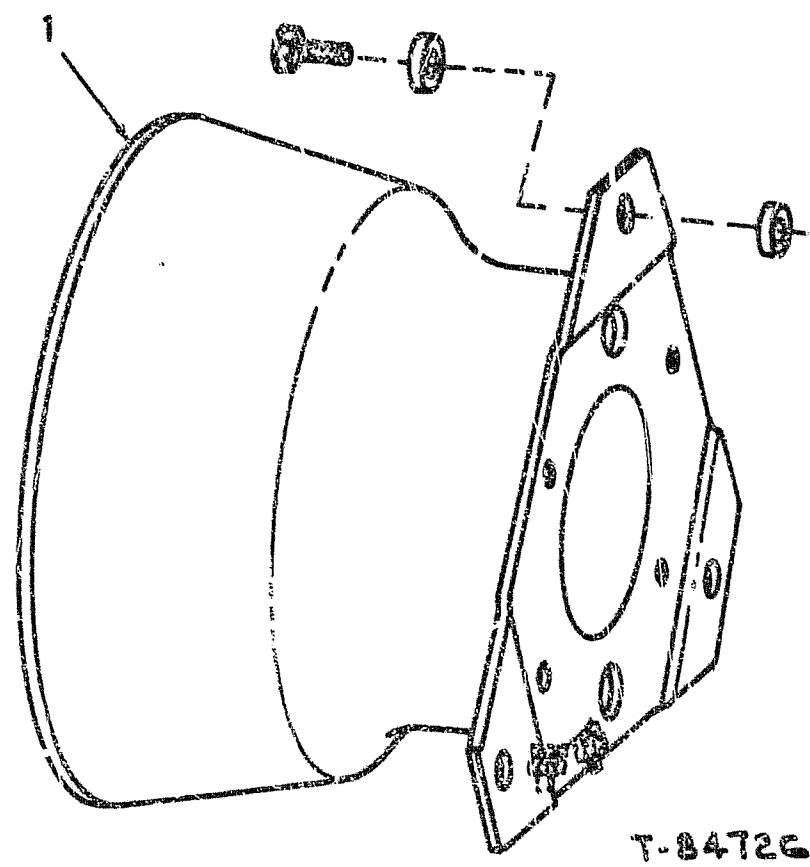

<p>707</p>	<p>BACK-UP ALARM AVUSATIRE RETRINARCUA AVERTUSSEYR DE RECYK RYCJSETZ-WARNHORN BOCINA DE RETROCESP</p>	<p>F501</p>	<p>2</p>
------------	---	-------------	----------

0-16

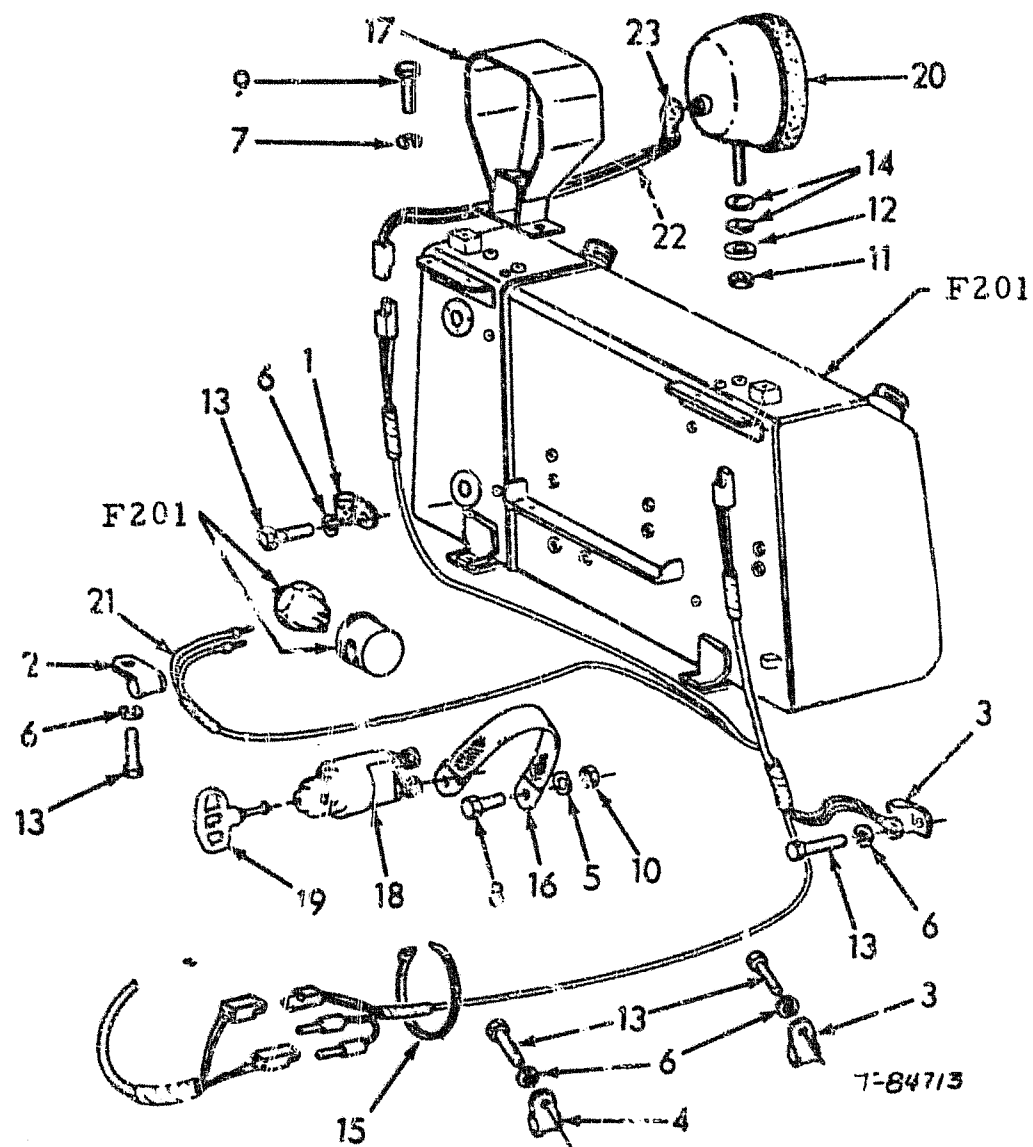

ITEM	PART NO.	QTY.	LEX.	DESCRIPTION	DEINOMIAZIONE
1	10449890	5	61S	RETAINER, 6 X 9	SCODELLINO DI RITEGNO
2	10450090	3	61S	RETAINER, 8 X 9	SCODELLINO DI RITEGNO
3	10450290	2	61S	RETAINER, 74 X 9	SCODELLINO DI RITEGNO
4	10450790	1	61S	RETAINER, 22 X 9	SCODELLINO DI RITEGNO
5	10517071	2	132R	LOCKWASHER, 12.2 X 3.1	ROSETTA DI SICUREZZA
6	10571771	11	132R	LOCKWASHER, 8.1 X 2	ROSETTA DI SICUREZZA
7	10571871	1	132R	LOCKWASHER, 10.2 X 2.2	ROSETTA DI SICUREZZA
8	10979331	1	40V	CAPSCREW, 10 X 1.5 X 14	VITE
9	11106231	2	40V	CAPSCREW, 10 X 1.5 X 25	VITE
10	11701721	1	10D	NUT, 10 X 1.5 X 8	DADO
11	70913744	1	10D	NUT, 1/2"NC	DADO
12	70926192	1	131R	WASHER	ROSETTA
13	16043031	11	40V	CAPSCREW, 8 X 1.25 X 12	VITE
14	76000905	2	74B	BLOCK	BLOCCHETTO
15	79013422	1	20M	BAND	NASTRO
16	79017173	1	166T	BRAID, GROUND	TRECCIA DI MASSA
17	79025861	1	300S	SUPPORT	SUPPORTO
18	79031355	1	75I	SWITCH	INTERRUTTORE
19	79032280	1	154C	KEY, LOCK	CHIAVE SERRATURA
20	-----	1	220P	HEADLAMP (F629(1))	PROIETTORE
21	79037301	1	111C	CABLE, ELECTRIC	CAVO ELETTRICO
			600M	REAR	POSTERIORE
22	73138199	1	111C	CABLE, ELECTRIC	CAVO ELETTRICO
23	10405485	1	330C	BOOT	CUFFIA DI PROTEZIONE

FD7

LIGHTING SYSTEM
ILLUMINAZIONE
ECLAIRAGE
BELEUCHTUNG
SISTEMA DE ALUMBRADO

F401

4

DESTINAZIONE BASE	BASIC DESIGNATION	DESIGNATIONS-BASES	GRUNDBEZEICHNUNGEN	DENOMINAZIONE BASE
319C	CRISTALLO ATERMICO	ATHERMIC GLASS PANE	GLACE ATHERMIQUE	CRISTAL ATERMICO
32GA	TRASMISSIONE POSTERIORE	REAR TRANSMISSION	TRANSMISSION ARRIERE	
320C	CROCIENA	SPIDER	CROISILLON	CRUCETA
3201	PNEUMATICI 14.00X24	TIRES 14.00 24	PNEUS 14.00X24	
3208	PNEUMATICI 15.5X25	TIRES 15.5X25	PNEUS 15.5X25	
3209	PNEUMATICI 17.5X25	TIRES 17.5X25	PNEUS 17.5X25	
321C	CRONOGIROMETRO	TACHOMETER	TACHYMETRE	CUENTAREVOLUCIONES
3210	PNEUMATICI 22X25	TIRES 22X25	PNEUS 22X25	
3211	PNEUMATICI 20.5X25	TIRES 20.5X25	PNEUS 20.5X25	
3213	PNEUMATICI 26.5X25	TIRES 26.5X25	PNEUS 26.5X25	
3219	PNEUMATICI 29.5X25	TIRES 29.5X25	PNEUS 29.5X25	
322C	CRONOTACHIMETRO	SPEEDOMETER	CHRONOTACHYMETRE	CRONOTACOMETRO
325C	CRUSCOTTO	DASHBOARD	PLANCHE DE BORD	TABLERO
330C	CUFFIA RADIATORE	RADIATOR GUARD	CAPOT	CAPUCHON
331C	CUFFIA DI GOMMA	RUBBER BOOT	CAPUCHON CAOUT- CHOUC	CAPUCHON DE CAUCHO
332C	CUFFIA PER PROIETTORE	HEADLAMP BOOT	CALOTTE DE PRO- JECTEUR	SOPORTE DEL PROJECTOR
333C	CUNEI	WEDGE	COIN	CUNA
334C	CUFFIA PARAPOLVERE	DUST BOOT	CAPUCHON POUR POUSSIER	CAPUCHON GUARDAPOVVO
3402	RUOTE CON CERCHIO 14.00-25	WHEELS W/RIM 14.00-25		
3403	RUOTE CON CERCHIO 8.00TG-24	WHEELS W/RIM 8.00TG-24		
341C	CUSCINETTO	BEARING	ROULEMENT	RODAMIENTO
345C	CUSCINO	CUSHION	COUSSIN	ALMOHADA
348C	CUSTODIA PER LIBRETTI	PORTFOLIO	POCHETTE A PAPIERS	FUNDA PARA MAPAS
36G5	BLOCCAGGIO IDRAULICO	HYDRAULIC LOCK	BLOCAGE HYDRAULIQUE	ANCLAJE HIDRAULICO
37G3	COMANDO FRENI SERVIZIO	BRAKE PEDALS		
37G4	COMANDO FRENI STAZIONAMENTO	PARKING BRAKE	FREINS DE STATIONNEMENT	
39G2	COMANDO FRIZIONI DI STERZO	STEERING CONTROL		
39G6	TUBAZIONI EST FRIZIONI STERZO	STEERING OUTER PIPING		
39G7	TUBAZIONI COLLEG.FRIZ.STERZO	STEERING CONNECTING PIPING		
390C	CORNICE DELLA TARGA	NUMBER PLATE FRAME	MONTURE DE PLAQUE	MARCO DE MATRICULA
390C				
391C	CORNICE DEL PROIETTORE	HEADLAMP RIM	MONTURE DE PRO- JECTEUR	MARCO DE PROJECTOR
391C				
397C	CORNICE DI GOMMA	WEATHERSEAL STRIP	CONTOUR CAOUTCHOUC	BURLETE DE GOMA
393C	CABINA SICUREZZA	ROPS CAB	CABINE DE SECURITE	CABINA DE SEGURIDAD
394C	CASSETTO DISTRIBUTORE	CONTROL VALVE SPOOL	BOITE DISTRIBUTEUR	CORREJERA DEL DISTRIBUIDOR
395C	COLORE	COLOR	COULEUR	COLOR
396C	CORPO TRATTORE	TRACTOR BODY	CORPS TRACTEUR	CUERPO TRACTOR

DESIGNAZIONE BASE	BASIC DESIGNATION	DESIGNATIONS-BASES	GRUNDEZEICHNUNGEN	DENOMINACIONES BASE
387C	CORPO CARRELLO	TRACK FRAME	LAUFWERKSAHMEN	CARRÓ DE ORUGA
398C	CRISTALLO COLORATO	TINTED ATHERMIC GLASS PANE	SCHIEBEGETÖENT	CRISTAL COLOREADO
399C	CONVERTITIC E PNEUMOIDRAULICO	POWER CLUSTEP	HYDROPNEUMATISCHE SERVOBREMSE	SERVOFRENO NEUMOHIDRAULICO
400C	COMBUSTIBILE	FUEL	KRAFTSTOFF	COMBUSTIBLE
401C	COSTAMPATO	MOLD-ON CONNECTOR		
401S	SARACINESCA	GATE VALVE	VANNE	COMPUERTA
402S	SCATOLA CAMBIO	TRANSMISSION HOUSING	BOITE DE VITESSES	CAJA DE CAMBIO
403S	SCATOLA RIDUTTORE FINALE	FINAL DRIVE HOUSING	CARTER DE REDUCTEUR FINAL	CAJA DE REDUCTOR
404S	SCATOLA TRASMISSIONE	REAR HOUSING	CARTER PONT ARRIERE	CAJA DE TRANSMISION
405S	SIGILLANTE	SEALANT	PRODUIT D'ETANCHEITE	SELLADOR
405G	SPRUZZATORE	NOZZLE	GICLÉUR	INJECTOR
407S	STIPESIA ANTISORUCCIOLO	ANTI-SKID	BANDE ANTIDERAPANTE	TIRA CONTRA-DESGLIZAMIENTO
408S	STIPESIA PROTEZIONE	ROPS CANOPY	STRUCTURE DE PROTECTION	ESTRUCTURA DE PROTECCION
409S	SERBENTIO FRENO	BRAKE LINING	SEGMENT DE FREIN	ZAPATA DE FRENO
410S	SERRATOIO OLIO IMP. IDRAULICO	HYDRAULIC TANK	RESERVOIR HYDRAULIQUE	DEPOSITO ACEITE SISTEMA HIDR.
411S	SERRATOIO COMBUSTIBILE E OLIO	FUEL AND OIL TANK	RESERVOIR COMBUSTIBLE-HUILE	TANQUE COMBUSTIBLE Y ACEITE
412S	SEMIMAGLIA CINGOLO	HALF TRACK LINK	DEMI-MAILLON	SEMIMALLA DE ORUGA
413S	SEMICHARNIERA	HALF HINGE	DEMI-CHARNIERE	SEMIBISAGRA
414S	SCHEMA	SCHEMATIC	SCHEME	ESQUEMA
415G	SEMIFASCIA	HALF BAND	DEMI-BANDE	SEMIFAJA
416S	SBRIGATORE	DEFROSTER	DEGIVREUR	DESCONGELADOR
417S	SEMIFLANGIA	HALF FLANGE	DEMI-BRIDE	SEMIBRIDA
418S	SERIE	SET	JEU	JUEGO
419S	SGANCIO SOLLEVAMENTO	LIFT RELEASE VALVE		
420S	SERBATOIO ARIA	AIR RESERVOIR	RESERVOIR A AIR	DEPOSITO DE AIRE
421S	SOLVENTE	SOLVENT	SOLVANT	
469P	PER VARIANTE	FOR SPECIAL EQUIPMENT	POUR VARIANTE	PARA VARIANTE
480A	RIDUTTORE LATERALE	FINAL DRIVE	REDUCTEUR LATERAL	
490P	PERNO A SFERA	BALL PIN	AXE SPHERIQUE	ROTULA
491P	POZZETTO	WELL	ETUI	DEPOSITO
492P	PUNTA DENTE BENTIA	BUCKET TOOTH POINT	POINTE DENT DE GOÛET	PUA DE DIENTE CUCHARA
493P	PIATTAFORMA	PLATFORM	PLATE-FORME	PLATAFORMA
5061	RUOTE CARPELLO CINGOLO	TRACK ROLLERS	ROUE PORTEUR DE CHENILLE	RUEDA DE APOYO DE LA ORUGA
5062	TENDICINGOLO	TRACK IDLER	TENDEUR DE CHENILLE	
5063	RULLO SOSTEGNO CINGOLO	TRACK CARRIER ROLLER	GALET DE RETOUR DE CHENILLE	BIECA DE SOPORTE DE LA ORUGA
5064	RIPARI CINGOLO	TRACK COVERS	PROTECTIONS DE CHENILLE	BRIGADA DE CASCOS
5061	SOSPENSIONE ANT CINGOLO	TRACK FRONT SUSPENSION	SUSPENSION AV CHENILLE	
5063	COLLEGAMENTO CARRELLI	TRACK GUIDING PLATES		
5065	SOSPENSIONE POST CINGOLO	REAR SUSPENSION	SUSPENSION AR CHENILLE	
606J	VARIANTE A RICHIESTA	SPECIAL EQUIPMENT	EQUIPEMENT SPECIAL	EQUIPO SPECIULE

DESIGNAZIONE BASE	BASIC DESIGNATION	DESIGNATIONS-BASES	GRUNDBEZEICHNUNGEN	REMININACIONES BASE
600U	PROVEDERE IN LOCO	OBTAIN LOCALLY	A PROCURER SER	CONSEGUIR LOCALMENTE
600W	TAGLIARE DI MISURA	CUT AT ASSEMBLY	COUPER SELON BESOIN	CORTAR SEGUN NECESARIO
600X	FINO AL TELAIO...	UP TO SERIAL NO...	JUSQU'AU CHASSIS	HASTA EL ARMAZON...
600Y	DAL TELAIO...	FROM THE SERIAL NO	A PARTIR DU CHASSIS	A PARTIR DEL ARMAZON
601E	VEDERE NOTA	SEE NOTE	VOIR REMARQUE	VEASE NOTA
63G0	COMANDI DIREZIONALI	STEERING SYSTEM	COMMANDE DE DIRECTION	MANDO DE LA DIRECCION
65G3	COMANDI FRENO	BRAKE CONTROLS	COMMANDE DE FREINS	MANDO DEL FRENO
7117	LEVERAGGI	CONTROL LEVERS	TRINGLERIES	TIMONIERA
7211	TELAIO INFERIORE	LOWER MAIN FRAME	CHASSIS INFERIOR	ARMAZON INFERIOR
7215	TELAIO SUPERIORE	UPPER MAIN FRAME	CHASSIS SUPERIOR	ARMAZON SUPERIOR
74G0	BATTERIE, SEDE E RIPARI	BATTERY, SEAT AND SUPPORT	BATTERIE, SIEGE ET PROTECTION	
74B0	MOTORIDUTTORE TRASLAZIONE	DRIVE MOTOREDUCTION		
74B2	MOTORIDUTTORE ROTAZIONE	SWING MOTOREDUCTION		
75G8	IMPIANTO ELETTRICO	ELECTRICAL SYSTEM	SYSTEME ELECTRIQUE	
75G0	COMANDI ELETTRICI	ELECTRIC CONTROLS	COMMANDES ELECTRIQUE	ELEKTRISCHE STEUERUNG
75G1	APPARECCHI ELETTRICI	ELECTRICAL INSTRUMENTS	DISPOSITIFS ELECTRIQUES	ELEKTRISCHE ANZEIGENSTRUMENTE
75G3	CAVI AVVIAMENTO	STARTING CABLES	CABLES DEMARRAGE	STARTERKABEL
75G4	CAVI VARI	VARIOUS CABLES	CABLE DIVERS	MEHRENE KABEL
75G6	APPARECCHI ILLUMINAZIONE	LIGHTS	ECLAIRAGE	BELEUCHTUNG
75G8	TERMOMETRI E MANOMETRI	TEMPERATURE-PRESSURE GAUGES	THERMOMETRES ET MANOMETRES	TEMPERATUR UND MANOMETER
7874	BLOCCAGGIO TORRETTA	SUPERSTRUCTURE LOCKING	BLOCAGE SUPERSTRUCTURE	
8079	BENNA SCARICO BILATERALE	BILATERAL DISCHARGE BUCKET	COUET VIDAGE BILATERAL	SEITENABSCHAUFEL
82G8	IMPIANTO IDRAULICO	HYDRAULIC SYSTEM	SYSTEME HYDRAULIQUE	SISTEMA HYDRAULICO
82G0	TUBAZIONI	PIPING		
82G1	FILTRI SERBATOIO OLIO	OIL TANK FILTERS		LEITUNGEN
82G3	POMPA ATTREZZO	EQUIPMENT PUMP	POMPE OUTIL	HYDR.FILTER
82G4	DISTRIBUTORE ATTREZZO	EQUIPMENT CONTROL VALVE	DISTRIBUTEUR DE L'OUTIL	HYDRAULIKPUMPE
82G5	COMANDO DISTRIBUTORE ATTREZZO	CONTROL VALVE DRIVE	COMMANDE DE OUTIL	STEUERGEHAETIARBEITSHYDRAULIK
82G6	TUBAZIONI IMPIANTO IDRAULICO	HYDRAULIC SYSTEM PIPING		HYDRAULIK-STEUERUNG
83G0	COFANI	HOODS	CAPOTS	LEITUNGEN FUER HYDRAULIKSYSTEM
83G6	RIPARI LATERALI COFANO	HOOD SIDE GUARDS	PROTECTIONS LATERALES CAPOT	MOTORHAEBEN
85G0	SEDILE CONDUTTORE	OPERATOR SEAT	SIEGE OPERATEUR	SEITENBLECHE
85G2	SOSTEGNO E RIPARI SEDILE	SEAT SUPPORT AND GUARD	SUPPORT ET PROTECTION SIEGE	FAHRERSITZ
8501	CATENARIA ANTIPOLVERE	SEALED TRACK CHAIN	CHENILLE SCHELLE	SITZBEFESTIGUNG UND VERKLEIDUNG
8582	CABINA COPERTATA	BULLETPROOF CAB	CABINE BLINDEE	KETTENZUG MIT STAUBDICHTUNG
87G8	POSTO GUIDA	OPERATORS COMPARTMENT		FAHRERHAUS GEPANZERT
87G0	PARAFANGHI PAVANE	FENDERS-FLOORS	AILES - PLANCHERS	
87G1	PROTEZIONI INFERIORI	BOTTOM GUARDS	PROTECTION INFERIEURS	KOTFLUEGEL-TRITTBLECH
8877	STRUTTURA ROPS RIVESTITA			PANZERWANNE
8905	SOSTITUIZ RAPIDA OLIO MOTORE	ENGINE OIL QUICK CHANGE		ROPS RAHMEN VERKLEIDET

DESIGNAZIONE BASE	BASIC DESIGNATION	DESIGNATIONS-BASES	GRUNDBEZEICHNUNGEN	DESIGNACIONES BASE
9007	IMP. PROTEZIONE MOTORE	ENGINE PROTECTION		
9016	ALLESTIMENTO USAF	USAF PROVISION		
9110	SENZA CILINDRI SOLLEVAMENTO	LIFT CYLINDERS DEDUCTION	SANS CYLINDRES SOULEVEMENT	OHNE HUBZYLINDER
9113	SENZA TUBAZ E CILINDRI SOLLEV	LIFT CYLINDERS & PIPING DEDUCT	SANS TUBANT. ET SYL. SOUL.	OHNE LEITUNGEN UND HUBZYLINDER
9115	BLOCCAGGIO ARTICOLAZ BRACCI	BOOM LINKAGE LOCK	BLOCCAGE ARTICULATION BRAS	HUBGESTENGEARRETTERUNG
9116	ALLESTIMENTO FANA	FAN% PROVISION		
9117	PREPARAZIONE P/SPEDIZIONE	SHIPPING PREPARATION		
9130	SENZA DISPOSITIVO EQUISTATIC	EQUISTATIC DEVICE DEDUCTION	SANS DISPOSITIF EQUISTATIQUE	OHNE EQUISTATIK
9159	SENZA VERNICIATURA A SMALTO			
9200	SENZA BOZZELLI GANCIO	HOOK SHEAVES DEDUCTION	SANS MOULE DE CROCHET	OHNE HAKENSEILBLOCK
9206	SPECIAL CONTRACT	SPECIAL CONTRACT		
9220	SENZA ZAVORRE POSTERIORI	REAR COUNTERWEIGHT DEDUCTION	SANS LESTS . PIERRES	OHNE KONTERGEWICHT HINTER
9225	SENZA COMANDO FREE FALL	FREE FALL CONTROL DEDUCTION	SANS COMMAN DE FREE FALL	OHNE FREIFALL-EINRICHTUNG
9230	SENZA ZAVORRA E SOPPORTO (ANT)		SANS LEST ET TAPP (AV)	OHNE KONTERGEWICHT/KONSOLE VOR
9232	SENZA ZAVORRE LATERALI	SIDE COUNTERWEIGHT DEDUCTION	SANS LESTS LATERAUX	OHNE SEITLICHES KONTERGEWICHT
9242	SENZA PNEUMATICI	TIRE OMISSION	SANS PNEUS	OHNE REIFEN
9491	SENZA PNEUMATICI E CERCHI	TIRE AND WHEEL OMISSION	SANS PNEUS ET . ERICLES	OHNE REIFEN UND FELSEN
9506	SENZA SUOLE	SHOES DEDUCTION	SANS PATINS	OHNE KETTENPLATTEN
9512	SENZA CATENARIA E SUOLE	TRACK CHAIN & SHOES DEDUCTION	SANS CHEMILLE ET PATINS	OHNE KETTENZUG UND PLATTEN
9580	SENZA CABINA	CAB OMISSION		
9902	SENZA RISCALDATORE	HEATER DEDUCTION	SANS CHAUFFAGE	OHNE HEIZUNG
9033	SENZA EMERGENCY STEERING	EMERGENCY STEERING DEDUCTION	SANS DIRECTION D'EMERGENCE	OHNE NOTLENKUNG
976A	FORNITURE ESTERNE	PURCHASED FINISH (I. F.)		
9765	COMANDI MOTORE (PF MOTORE)	ENGINE CONTROLS (ENGINE PF)		MOTORSTEUERUNG
9761	SENZA BACK UP ALARM	BACK UP ALARM DEDUCTION	SANS BACK UP ALARM	OHNE RUECKFAHRWARNANLAGE
9060	TARGHE E MANUALI	MANUALS AND DECALS	PLAQUES ET MANUELS	KLEBESCHILDER UND HANDBUECHER
9067	TARGHE D'IDENTIFICAZIONE	IDENTIFICATION PLATES	PLAQUE D'IDENTIFICATION	TYPENSCHILDER
9062	MARCHI DELLA DITTA	TRADE MARKS		FIRMENZEICHEN
9640	SENZA RIBALTAMENTO SEDILE			
9650	SENZA SEDILE	SEAT DEDUCTION	SANS SIÈGE	OHNE SITZ
9851	SENZA SEDILE E SOPPORTO	SEAT AND PEDESTAL DEDUCTION	SANS SIÈGE ET SUPPORT	OHNE SITZ UND KONSOLE
9876	SENZA STRUTTURA PROTEZIONE	ROPS CANOPY DEDUCTION	SANS STRUCTURE DE PROTECTION	OHNE SCHUTZRAHMEN
9890	SENZA BARRA DI TRAINO	SWINGING DRAWBAR DEDUCTION	SANS BARRE D'ATTelage	OHNE ZUGPENDEL
9891	SENZA GANCIO TRAINO	DRAWBAR DEDUCTION	SANS CROCHET D'ATTALAGE	OHNE ZUGHAKEN
9960	DOTAZIONI FINALI	FINAL PREPARATION		
9968	LUBRIFICANTI	LUBRICANTS	LUBRIFIANTS	
				SIN ESTRUCTURA DE PROTECCION