

CLARK

SHOP MANUAL

No. 3275

HYDRAULIC CYLINDERS



CLARK WARRANTY

CLARK warrants each new Construction Machinery Group product, including attachments and accessories thereto, sold by it to be merchantable and free from defects in material and workmanship.

CLARK will cause any part of a CLARK product covered by this warranty (except as excluded below) which proves to be defective in material or workmanship during six (6) months immediately following the delivery of said product to the person who first puts it into use, to be replaced without charge with a new or repaired part (whichever CLARK elects). CLARK also will cause the labor to remove any such defective part and to install the new or repaired part to be provided without charge to the owner of said CLARK product. The parts and labor to meet this warranty will be furnished by a CLARK distributor designated by CLARK.

CLARK also warrants each replacement part for the products covered by this warranty sold by it to be merchantable and free from defects in material and workmanship. CLARK will cause any such replacement part which proves to be defective during the first six (6) months following its installation in a CLARK product to be replaced, without charge, with a new or repaired part (whichever CLARK elects).

CLARK'S warranty *does not cover*: (i) the replacement of parts found to have been damaged by abuse, accident or a failure to maintain or use the CLARK product or part according to the instructions applicable to it, (ii) the labor to remove and reinstall a defective replacement part after the expiration of the warranty period applicable to the product in which such part is located, (iii) overtime labor premiums, (iv) transportation of the CLARK product to the distributor's service facility or transportation of the distributor's service men to the product's location, (v) the engine or the tires of any CLARK product, nor does it cover the carrier on any truck mounted hydraulic cranes. The warranty of the respective manufacturers of these components shall apply to said items unless said manufacturers make no warranty with respect to said items, in which event CLARK'S warranty shall apply.

The Buyer accepts this warranty and the limitations of liability and disclaimers set forth herein as part of the purchase of the CLARK product or part to which this warranty applies.

THIS WARRANTY IS EXCLUSIVE AND IS IN LIEU OF ALL OTHER WARRANTIES EXPRESSED OR IMPLIED AND THERE IS NO IMPLIED WARRANTY OF MERCHANTABILITY OR FITNESS FOR A PARTICULAR PURPOSE.

Remedies available to any person claiming under this warranty are exclusive and expressly limited to obtaining the parts and the labor, where applicable, in accordance with terms of this warranty.

CLARK'S liability for losses, damages or expenses of any kind arising from its design, manufacture or sale of the products or parts covered by this warranty whether based on contract, tort or otherwise, including liability arising from a breach of this warranty, is limited, unless otherwise prohibited by law, to an amount not exceeding the cost of performing the obligations contained in this warranty according to its terms, and in no event shall CLARK'S liability exceed the value of the CLARK product giving rise to such liability.

CLARK disclaims all liability for loss, damage or expense attributable to a loss of use of the CLARK product, a loss or damage to property other than the CLARK product, a loss of profits or other commercial loss, or any special or consequential damages (except liability for consequential damages which by law may not be disclaimed).

The term CLARK means Clark Equipment Company or one of its subsidiaries, whichever last sold the product to which this warranty applies. The term Construction Machinery Group products refers to machines of the following types: Wheel loaders, wheel dozers, scrapers, log skidders, log loaders, motor graders, hydraulic cranes, cable cranes, excavators, and power shovels. (Not included are: lift trucks, straddle carriers, skid steer loaders, agricultural products or other products sold by CLARK'S Material Handling Group or the General Products Group).

Revised July 1981

IMPROVEMENTS

It is CLARK'S policy to constantly strive to improve its products. The right therefore is reserved to make changes in design and improvements whenever it is believed the efficiency of the product will be improved thereby, but without incurring any obligation to incorporate such improvements in any product which has been shipped or is in service.

CLARK

FOREWORD

This manual has been prepared to provide the customer and maintenance personnel with information on the repair of cylinders.

In order to become familiar with the parts of the cylinders and the special tools used in the disassembly and assembly operations, it is urged that the mechanic study the instructions in this manual before performing the operations.

The special tools shown in this manual will help to disassemble and assemble the cylinders without damaging the components. Instructions to make these tools are in the rear of this manual.

When repair or replacement of component parts is required, only Clark Approved Parts as listed in the applicable parts manual should be used. Use of "will fit" or non-approved parts may endanger proper operation and performance of the equipment. The Clark Equipment Company does not warrant repair or replacement parts, nor failures resulting from the use thereof, which are not supplied by or approved by the Clark Equipment Company.

CLARK

SAFETY

Before you begin your work, make sure your machine is in the service position. Observe these Safety rules. Work safely.

Bucket on the ground

Parking brake applied

Engine shut down

Ignition key removed

Red Warning flag tied on steering wheel

Safety link connected

Wheels blocked

Remove all pressure caps slowly to relieve pressure

*Let the machine become cool

*If work must be done on a warm machine, BE CAREFUL OF HOT liquids and components.



**A symbol which means:
WARNING! BECOME ALERT!
YOUR SAFETY IS INVOLVED!**

Safety Alert Symbol

CLARK

TABLE OF CONTENTS

DISASSEMBLY	1 thru 16
Remove the Rod Assembly from the Cylinder	1
Remove the Piston from the Rod Assembly	4
Remove the Cap from the Rod Assembly	6
Disassembly of the Piston	8
Disassembly of the Cap	10
Remove the Rod Seal	13
Remove the Buffer Ring Assembly	15
CLEANING AND INSPECTION	17 thru 18
ASSEMBLY	19 thru 35
Install the Buffer Ring Assembly	19
Install the Rod Seal	21
Assemble the Cap	23
Assembly of the Piston	26
Install the Cap on the Piston Rod	28
Install the Piston on the Rod	30
Install the Rod Assembly Into the Cylinder	32
CYLINDER TOOLS	36 thru 40
Seal Guide	36
Adjustable Spanner Wrench	38
Dowel Pin Puller	40

CLARK Cylinder Repack Kits



Maintain the performance your machine was designed to deliver.

When repacking cylinders, why risk the aggravation and misfortune of not ordering all parts required? Clark now offers kits for Clark Cylinders which include all the seals, rings and packings necessary for repacking one cylinder.

When ordering kits always furnish your local Clark distributor with the cylinder number and/or the model and serial number.

Clark Cylinder Repack Kits are designed to benefit in numerous ways the most important individual to us, you our customer.

Kits are designed to service the complete cylinder

Helps to eliminate confusion

Fewer part numbers to record and order

Less handling of parts

Clark Engineered Components

Everything is in one box

Helps your Planned Maintenance Program

Saves on down-time

Reduces possibility of searches for unanticipated parts

Reduces emergency requirements

Have everything at your finger tips

When ordering always furnish model and serial number and applications or part number of cylinder to be serviced.

DISASSEMBLY

1. Remove the rod assembly from the cylinder.

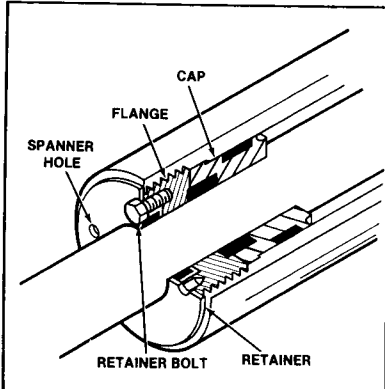

TS-21170

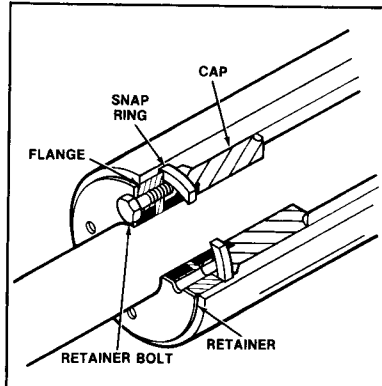

TS-21171

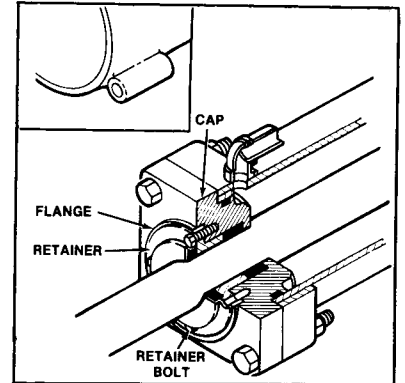

TS-21172

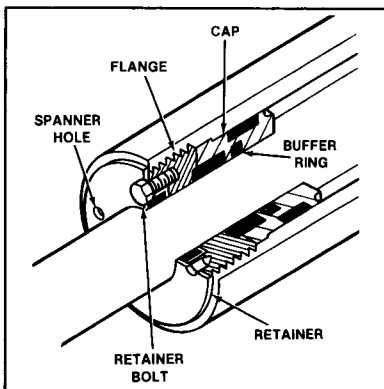

TS-21379

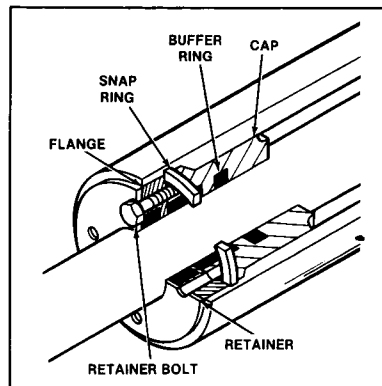

TS-21378

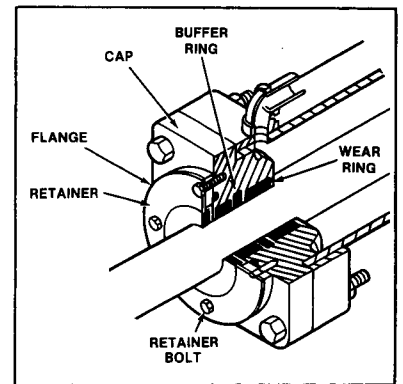

TS-21377

For cylinders with the cap fastened by a threaded flange. Steps A-F.

For cylinders with the retainer fastened by bolts and the cap fastened by a snap ring. Steps G-M.

For cylinders with a cap that is bolted on. Steps N-O.

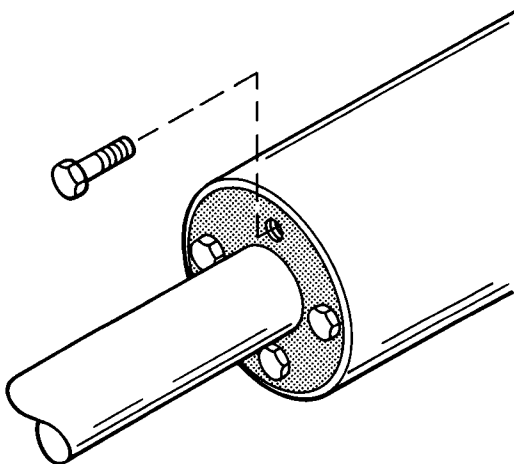

TS-21086

A. Remove the bolts from the retainer and flange, if used.

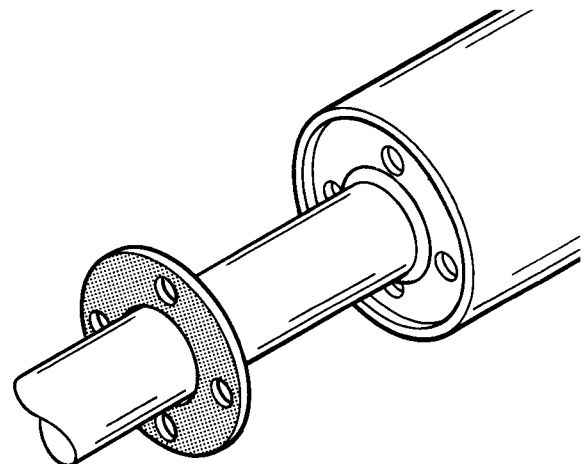

TS-21087

B. Move the retainer away from the flange, if used.

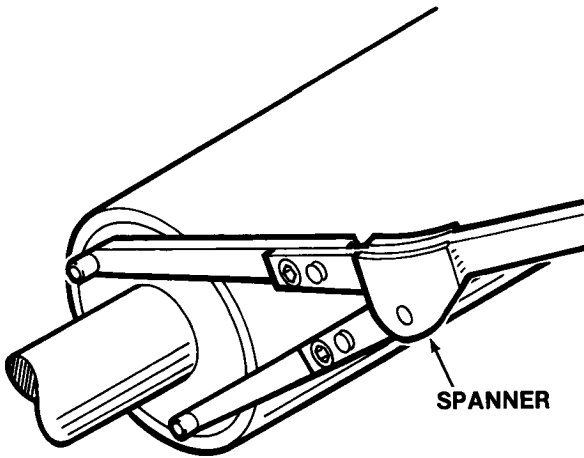

TS-21092

C. Turn the flange counterclockwise until it is out of the cylinder.

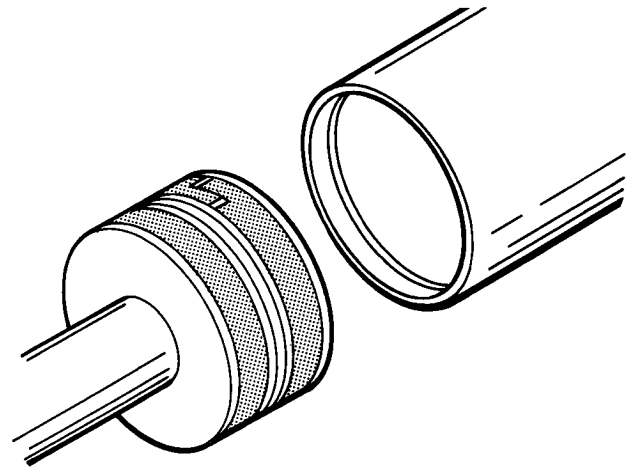

TS-21100

F. Remove the rod assembly from the cylinder. Some fluid will run out.

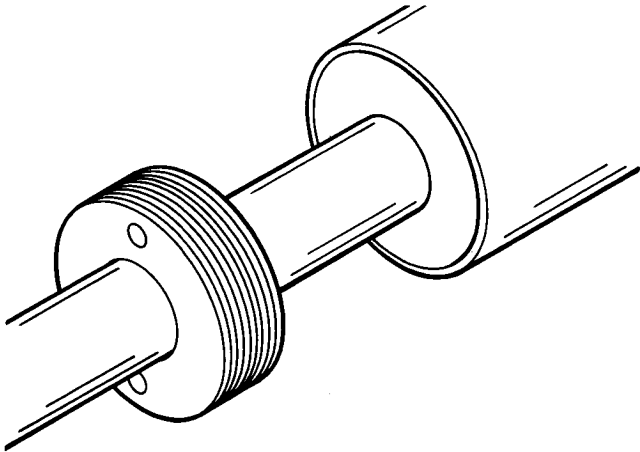

TS-21093

D. Move the flange away from the cylinder.

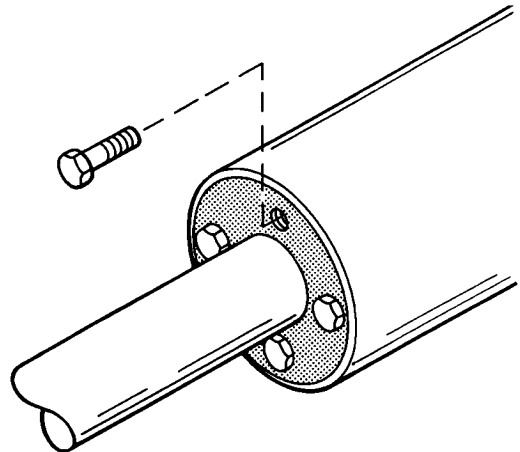

TS-21086

G. Remove the bolts from the retainer.

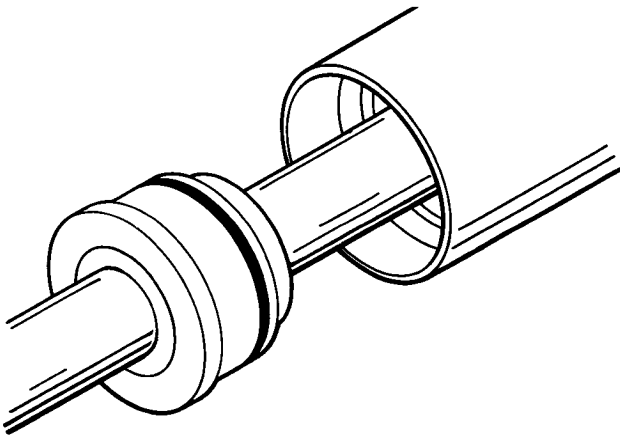

TS-21099

E. Slide the cap out of the cylinder. Some fluid will run out.

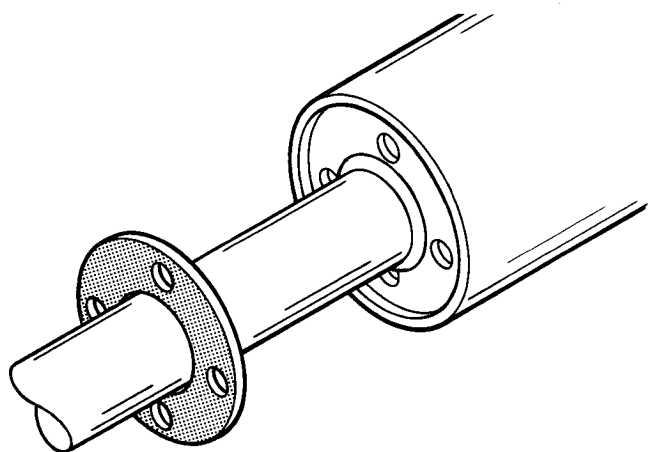

TS-21087

H. Move the retainer away from the flange.

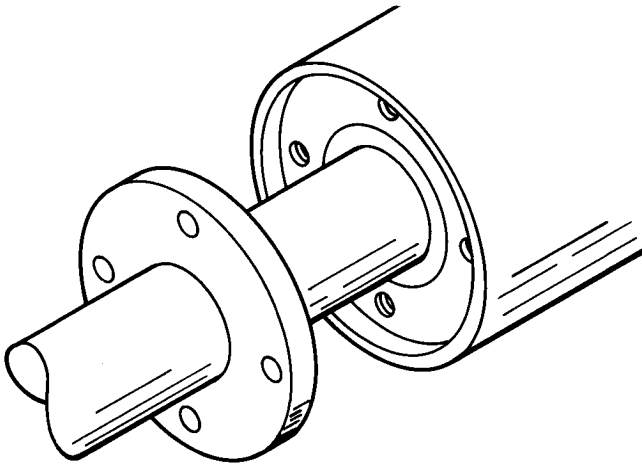

TS-21096

I. Slide the flange out of the cylinder, if used.

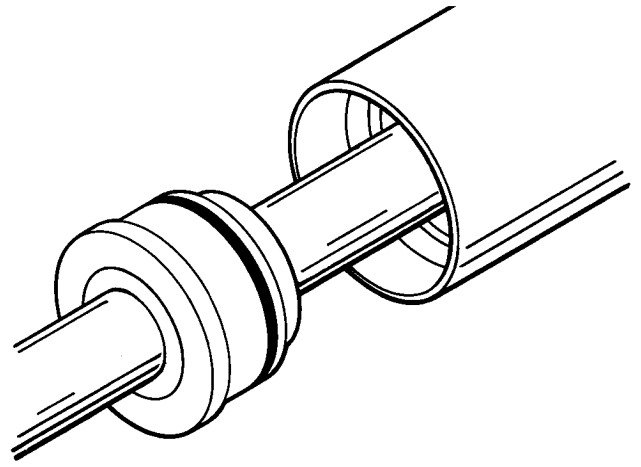

TS-21099

L. Slide the cap out of the cylinder. Some fluid will run out.

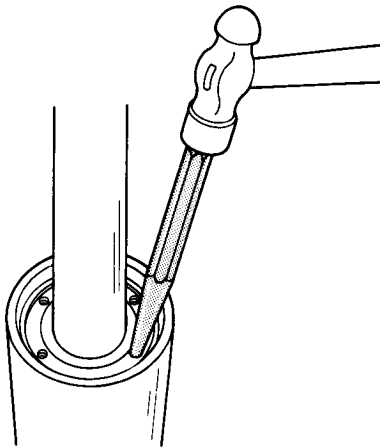

TS-21097

J. Push the cap into the cylinder until the snap ring can be removed.

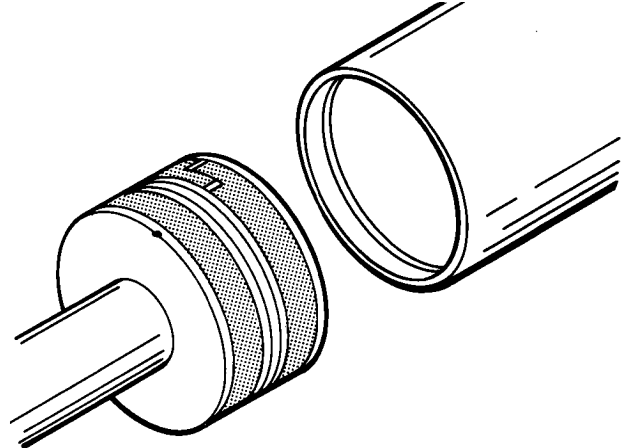

TS-21100

M. Remove the rod assembly from the cylinder. Some fluid will run out.

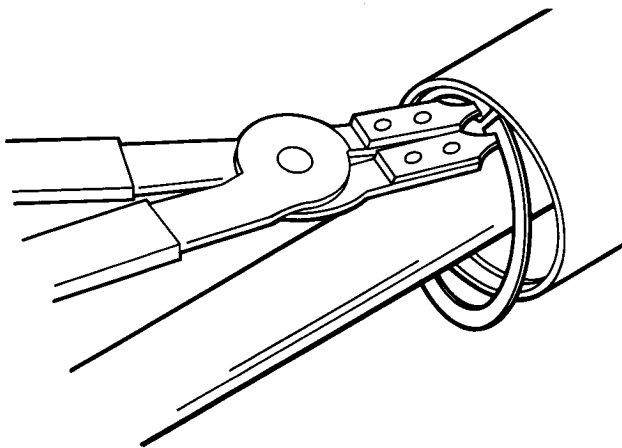

TS-21098

K. Remove the snap ring.

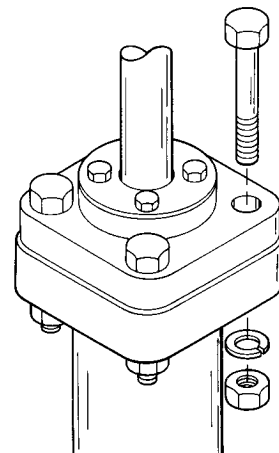

TS-21094

N. If there is a port in the cap, put alignment marks on the cap and cylinder. The marks will be aligned when the cap is installed. Remove the nuts from the cap, if used. Remove the bolts and washers from the cap.

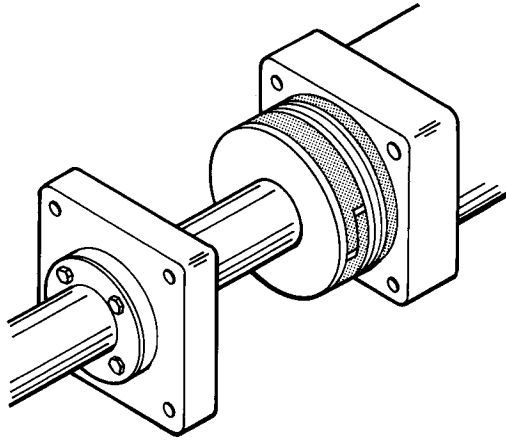

TS-21095

O. Remove the rod assembly from the cylinder. Some fluid will run out.

2. Remove the piston from the rod assembly.

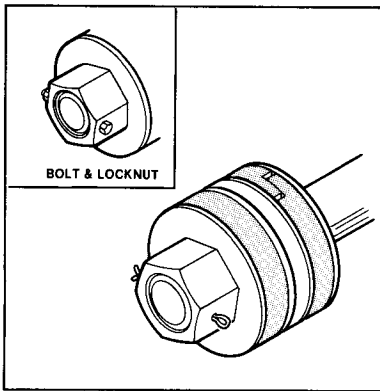

TS-21173

For a piston fastened with a nut held by a cotter pin or a bolt and locknut. Steps A-C.

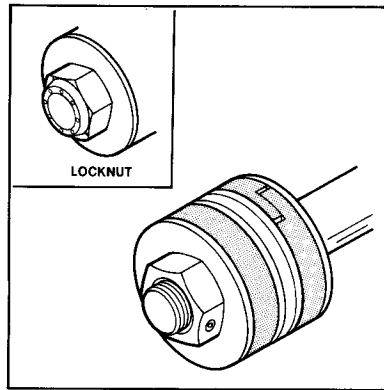

TS-21174

For a piston fastened with a nut held by a set screw or a locknut. Steps D-F.

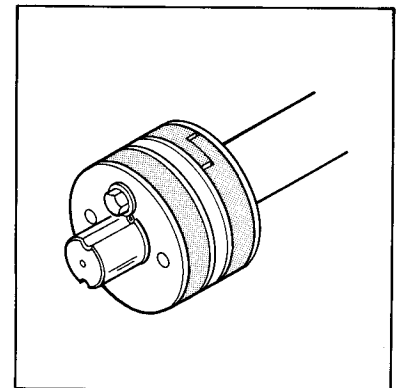

TS-21175

For a piston that is threaded inside. Steps G-J.

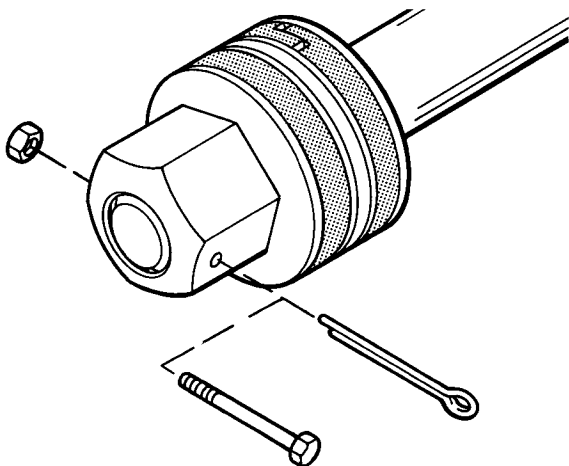

TS-21103

A. Remove the cotter pin or bolt and nut.

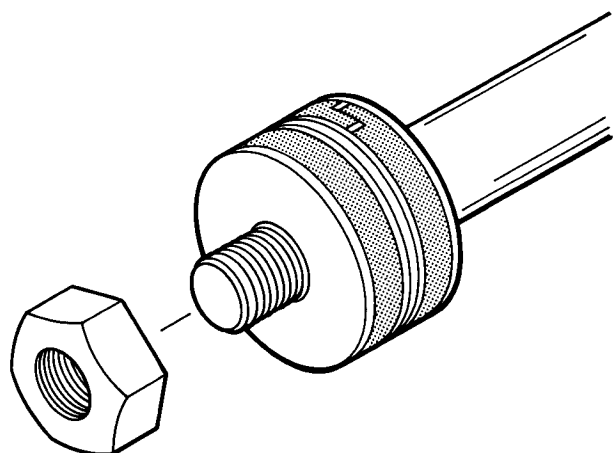

TS-21104

B. Remove the nut from the rod.

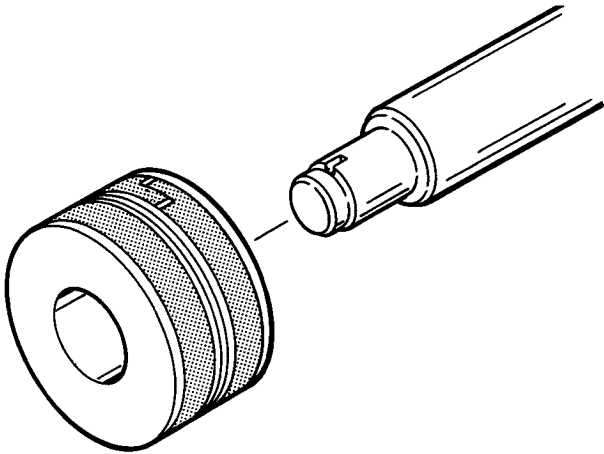

TS-21105

C. Remove the piston from the rod.

Note: If there is an o-ring in a groove in the rod, remove and discard it.

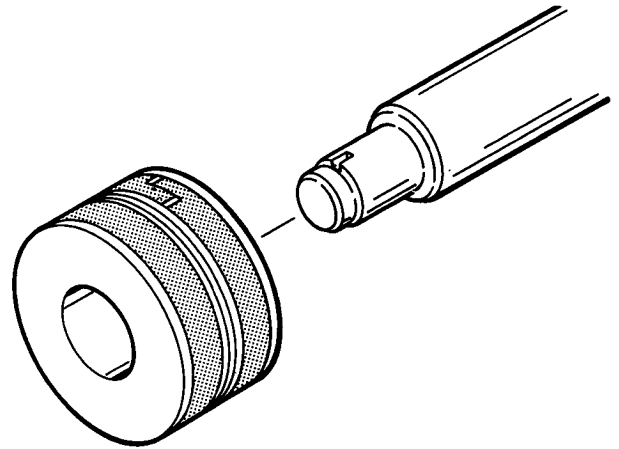

TS-21105

F. Remove the piston from the rod.

Note: If there is an o-ring in a groove in the rod, remove and discard it.

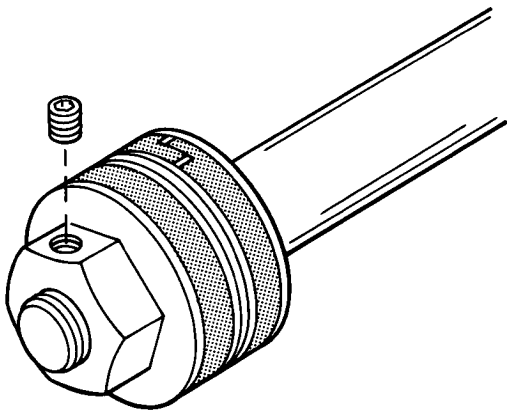

TS-21090

D. Loosen and remove the set screw, if used (some piston nuts use 2 set screws, remove both).

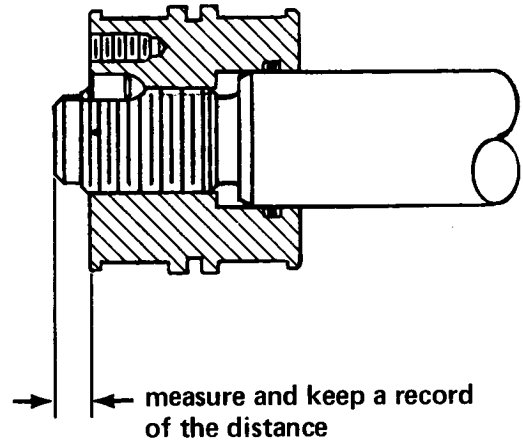

TS-15732

G. If the piston and rod are to be used again, make the measurement and keep a record of it.

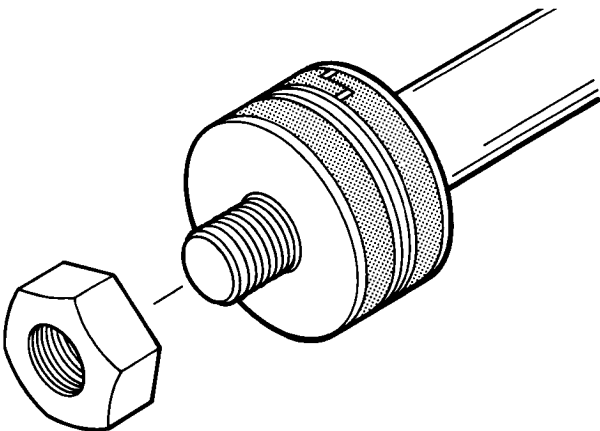

TS-21104

E. Remove the nut or locknut from the rod.

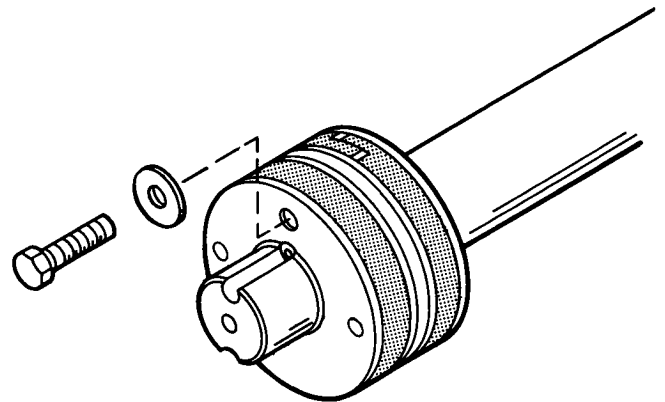

TS-21101

H. Remove the bolt and washer from the piston.

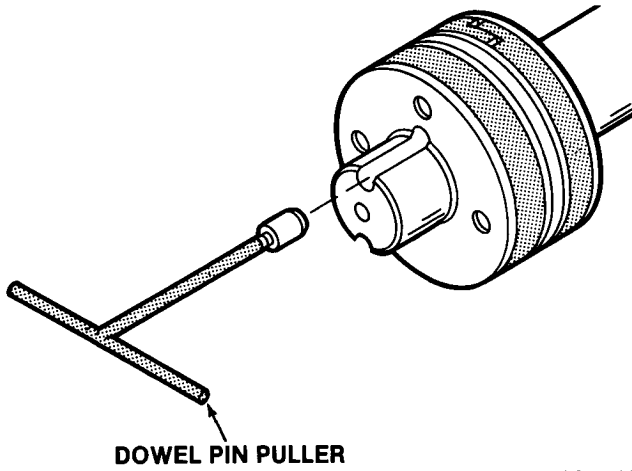

TS-21102

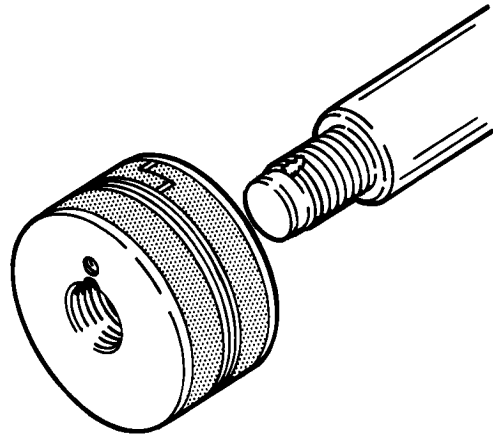

TS-16244

I. Pull the dowel pin out of the piston.

J. Turn the piston counterclockwise and remove it.

3. Remove the cap from the rod assembly.

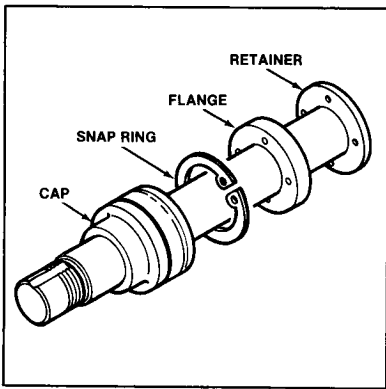

TS-21177

For a cap fastened by a snap ring. Steps A-D.

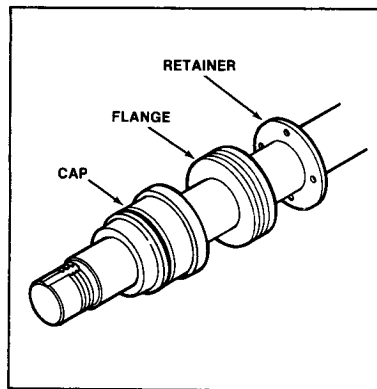

TS-21176

For a cap fastened by a flange with threads. Steps E-F.

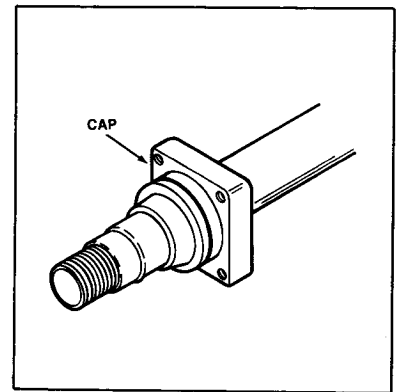

TS-21178

For a cap that is fastened by bolts. Step G.

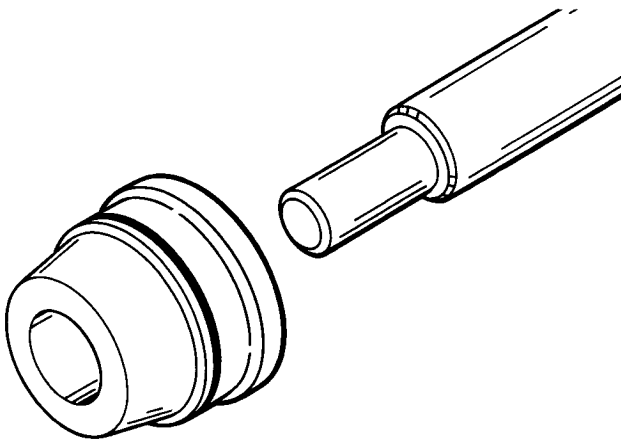

TS-21089

A. Remove the cap from the rod.

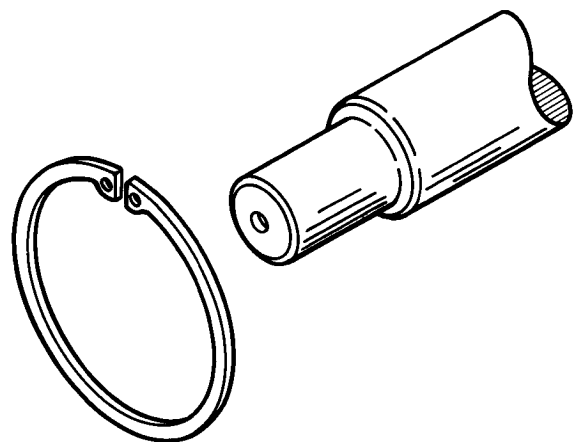

TS-21164

B. Remove the snap ring from the rod.

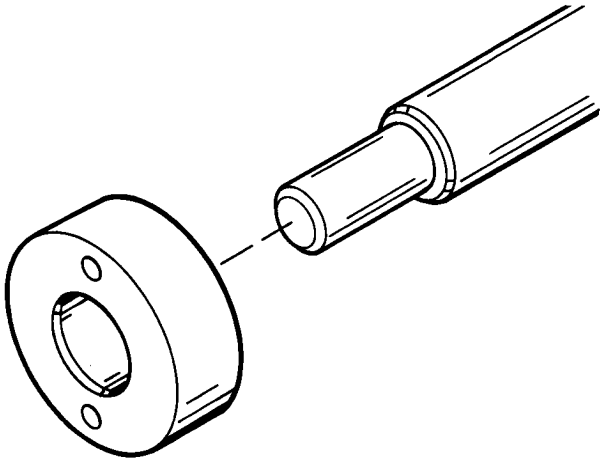

C. Remove the flange from the rod.

TS-21106

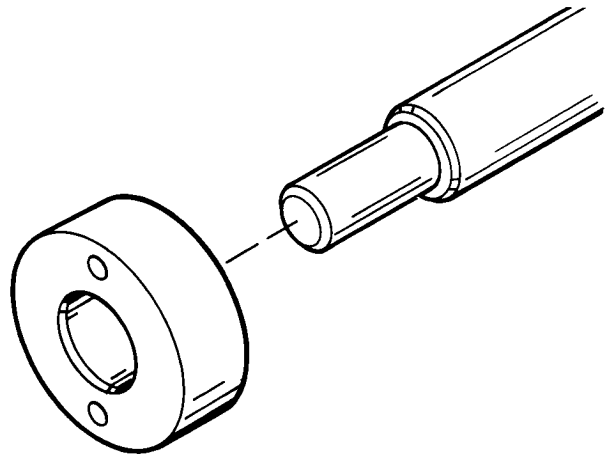

F. Remove the flange, with threads, from the rod. Remove the retainer, if used.

TS-21106

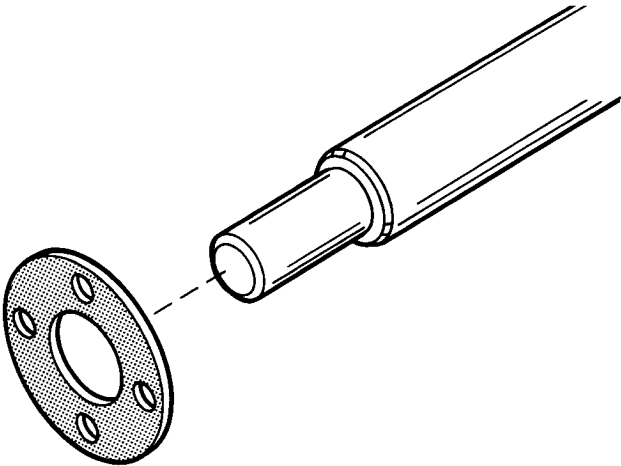

D. Remove the retainer from the rod.

TS-21088

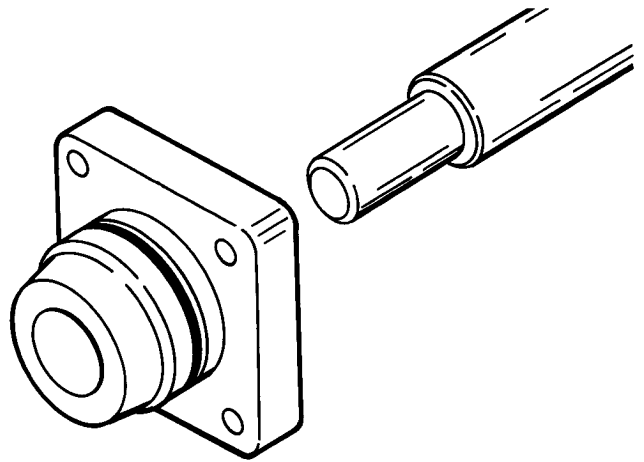

G. Remove the cap assembly.

TS-21135

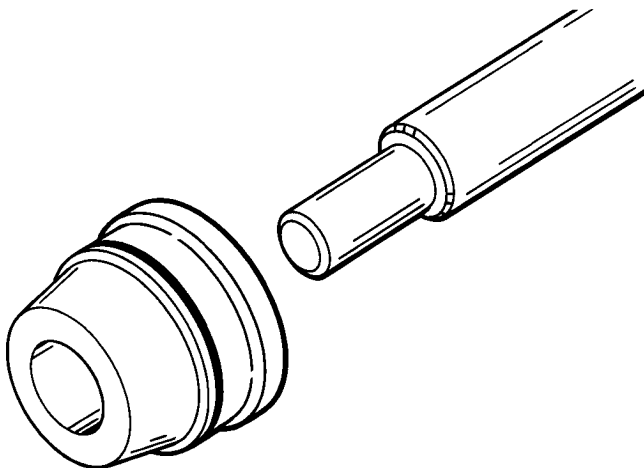

E. Remove the cap from the rod.

TS-21089

4. Disassembly of the piston.

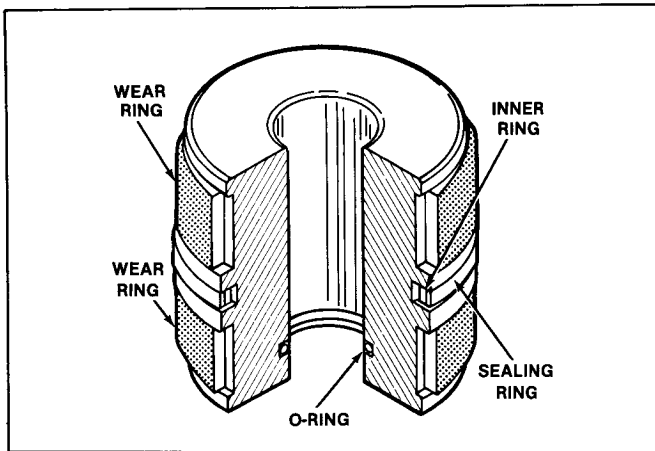

TS-21179

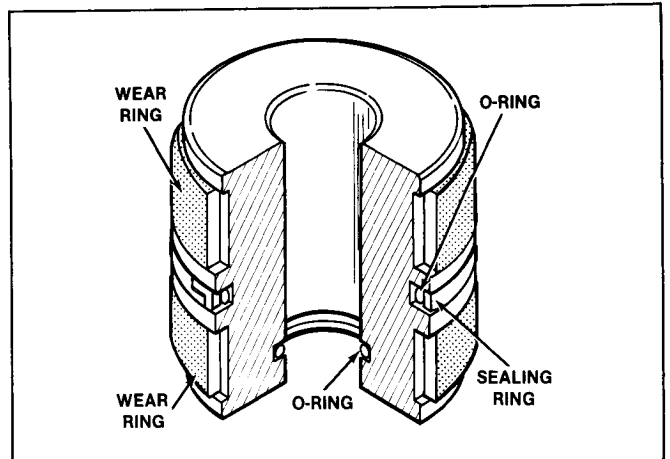

TS-21388

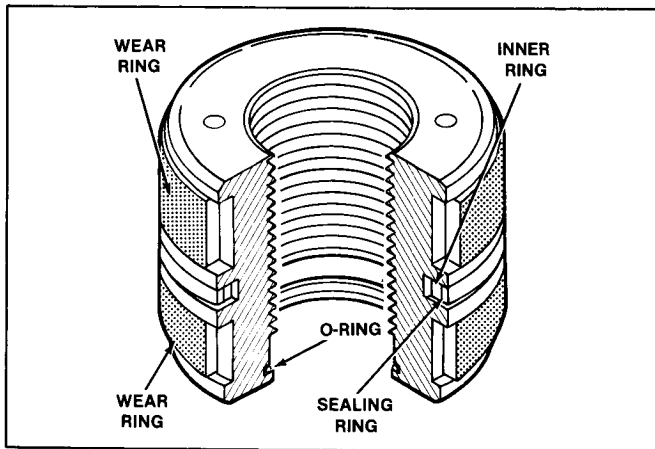

TS-21180

For pistons with no split in the sealing ring. Steps A-D.

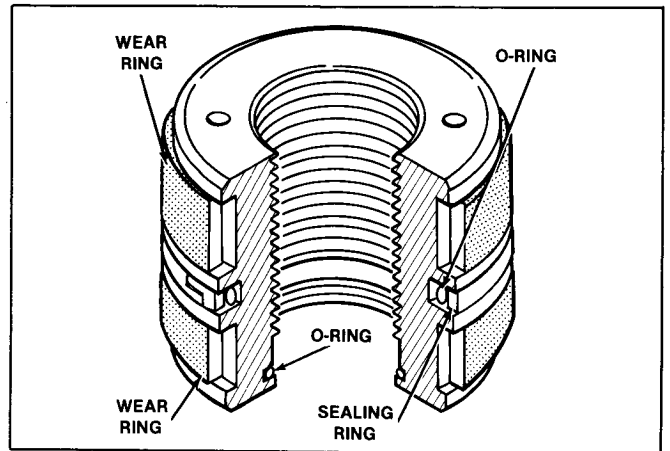

TS-21389

For pistons with a split piston sealing ring. Steps E-H.

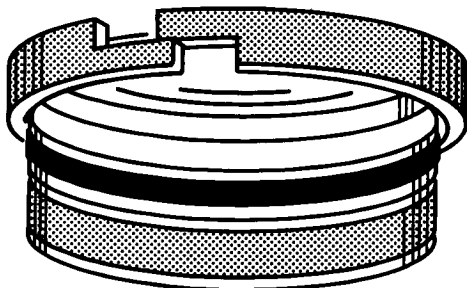

TS-21397

A. Remove and discard the wear rings.

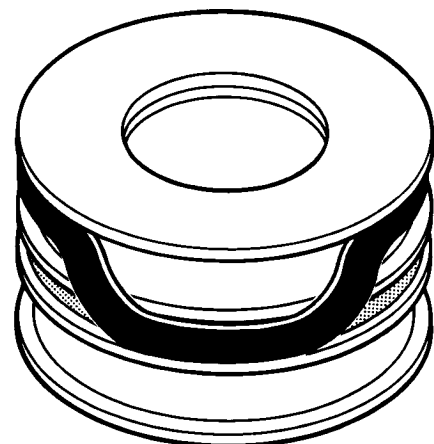

TS-21109

B. Remove and discard the sealing ring.

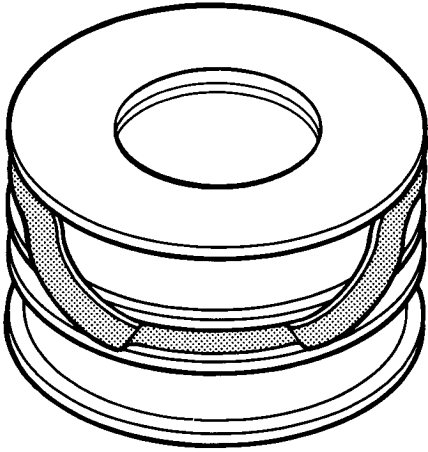

C. Remove and discard the inner ring.

TS-21110

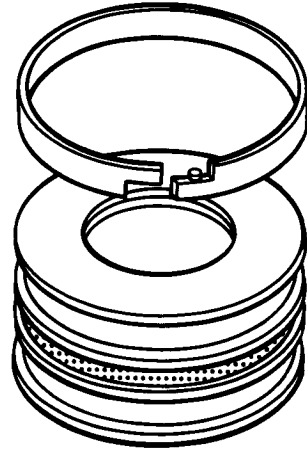

F. Remove and discard the sealing ring.

TS-21376

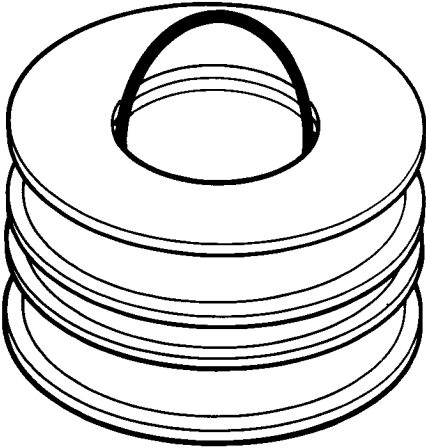

D. Remove and discard the o-ring, if used.

TS-21111

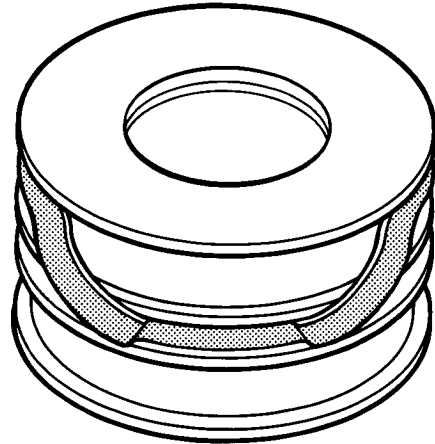

G. Remove and discard the o-ring.

TS-21110

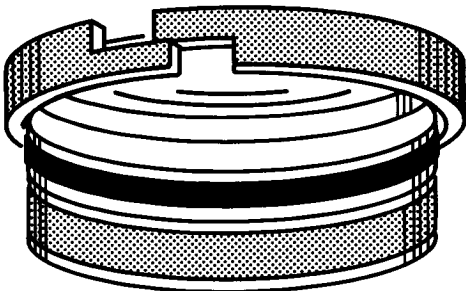

E. Remove and discard the wear rings.

TS-21397

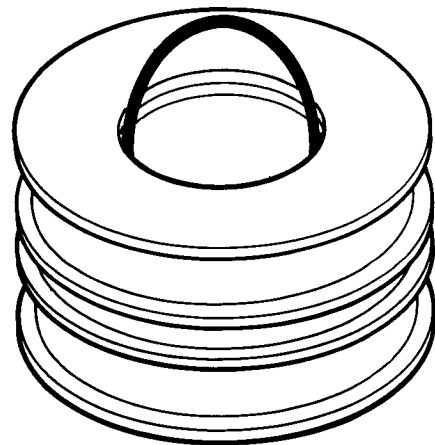

H. Remove and discard the o-ring, if used.

TS-21111

5. Disassembly of the cap.

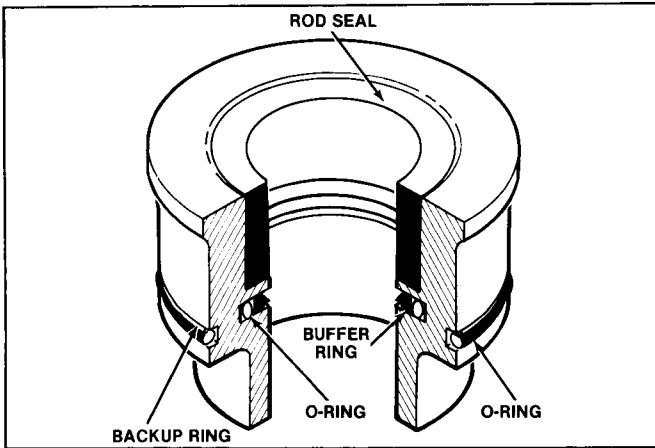

TS-21181

For caps that are fastened in the cylinder by a flange that is threaded or a snap ring. Steps A-D.

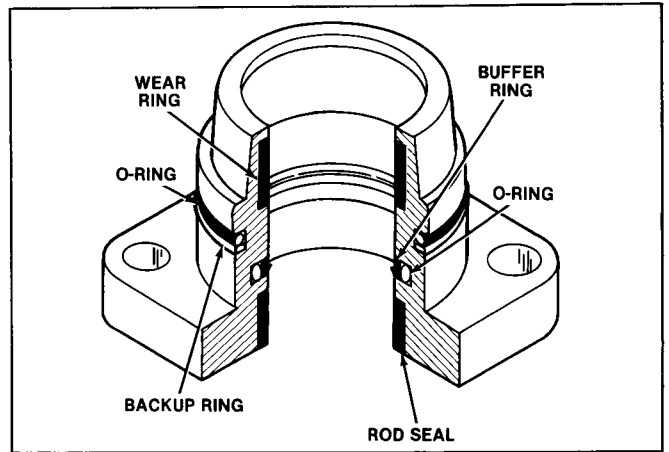

TS-21182

For caps that are fastened to the cylinder with bolts. Steps E-M.

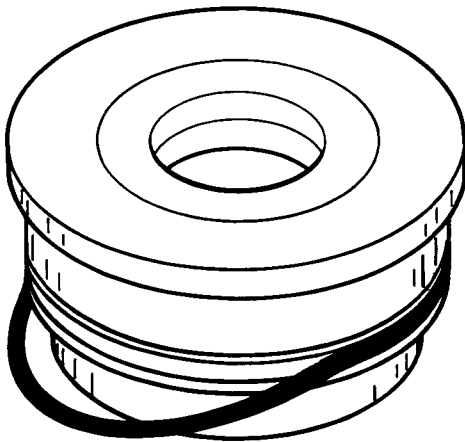

TS-21118

A. Remove and discard the o-ring from the cylinder cap groove.

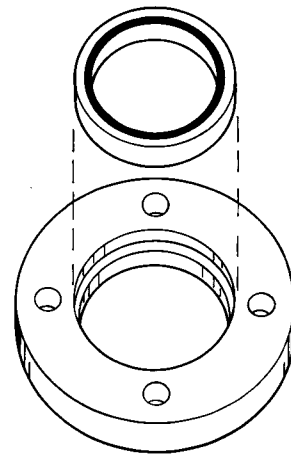

TS-21194

C. Remove and discard the rod wiper from the flange.

Note: Some cylinders have the wiper located in the cap. Remove and discard the wiper.

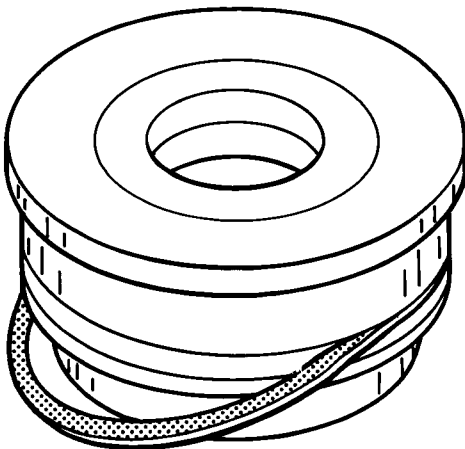

TS-21119

B. Remove and discard the backup ring.

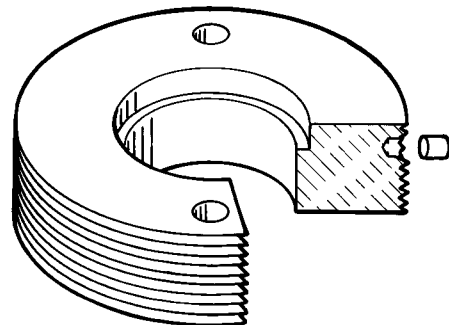

TS-16282

D. Remove the plug from the threaded flange, if used.

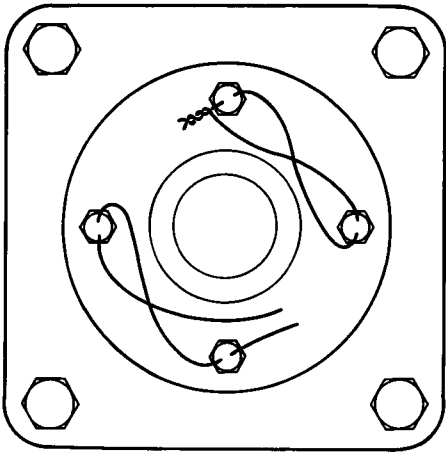

TS-21165

E. Remove and discard the lockwires, if used.

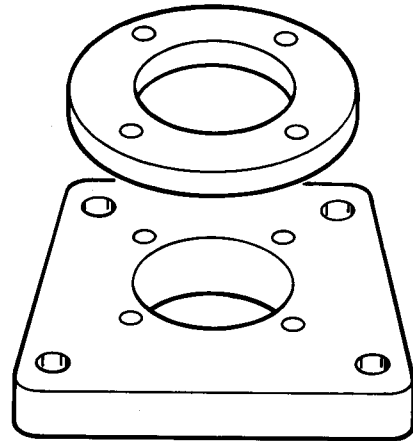

TS-21167

H. Remove the flange. Remove and discard the spacers, if used.

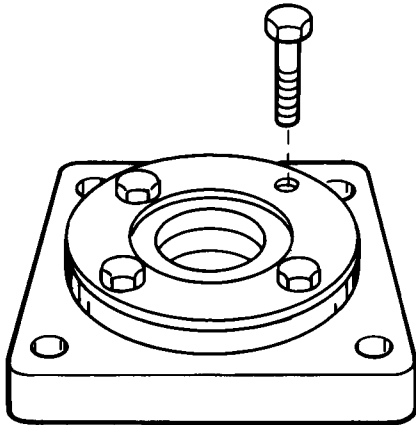

TS-21112

F. Remove the bolts that fasten the retainer to the cap, if used.

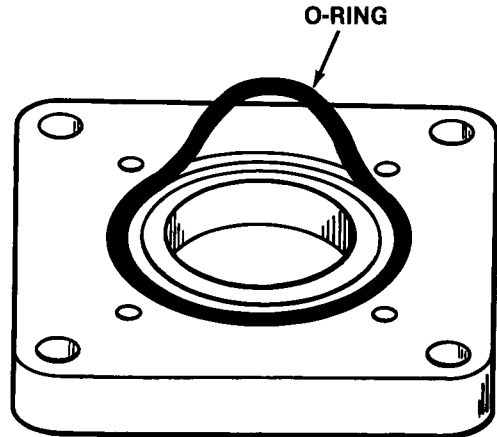

TS-21375

I. Remove the o-ring from the cap, if used.

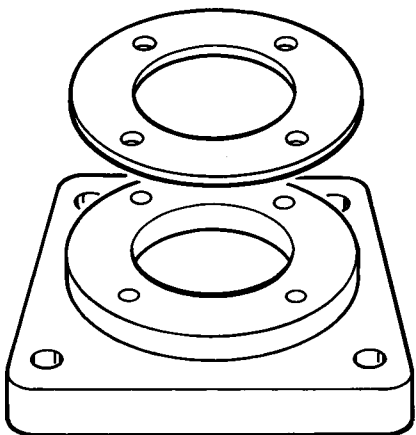

TS-21113

G. Remove the retainer, if used.

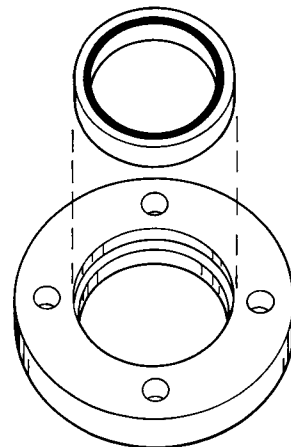

TS-21194

J. Remove and discard the rod wiper from the flange.

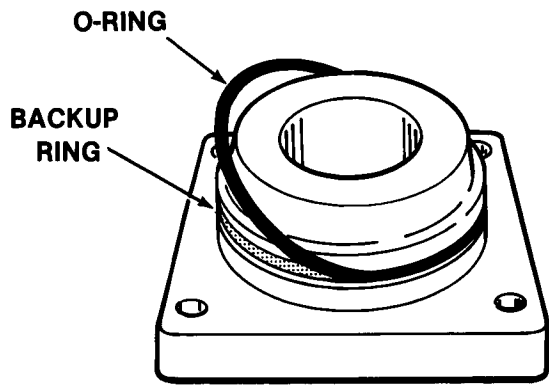

TS-21115

K. Remove and discard the o-ring.

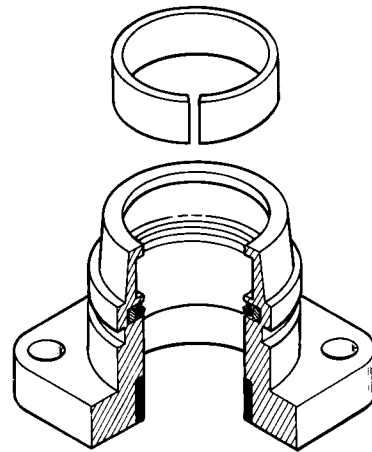

TS-21370

M. Remove and discard the wear ring, if used.

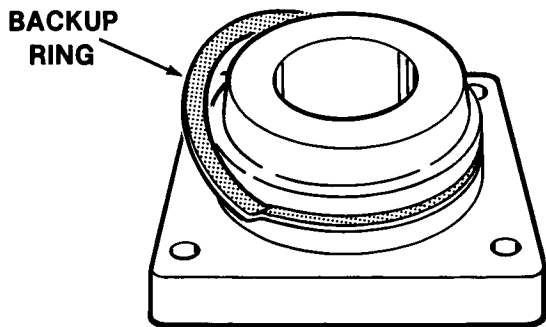

TS-21168

L. Remove and discard the backup ring.

6. Remove the rod seal.

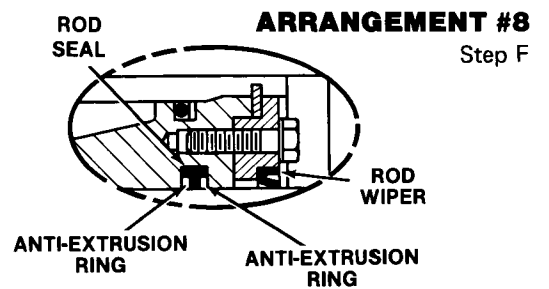
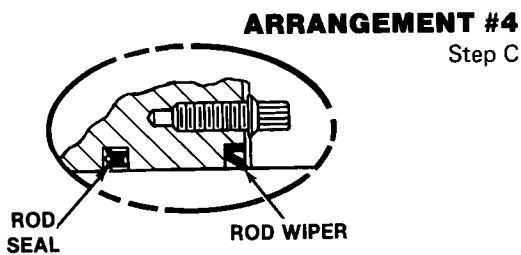
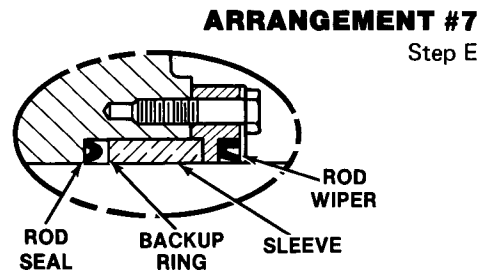
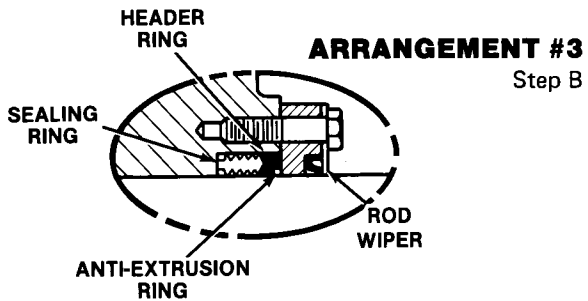
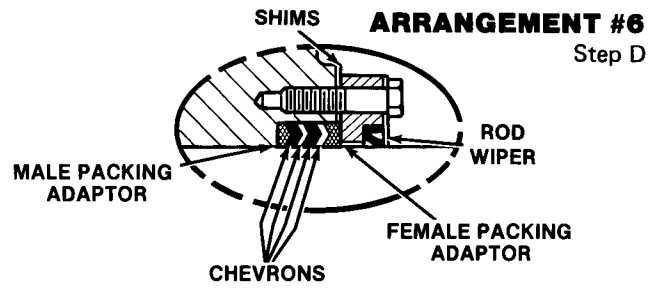
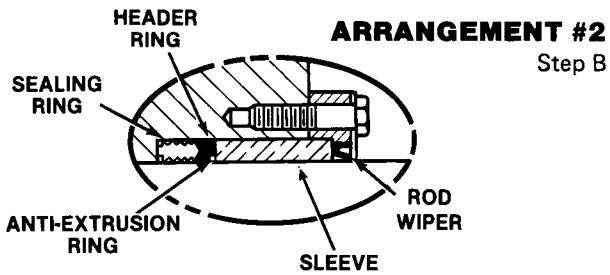
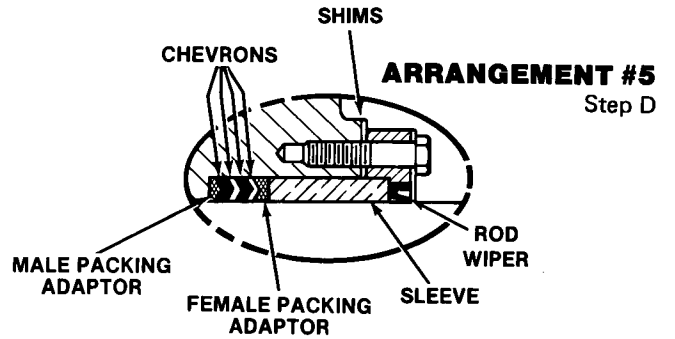
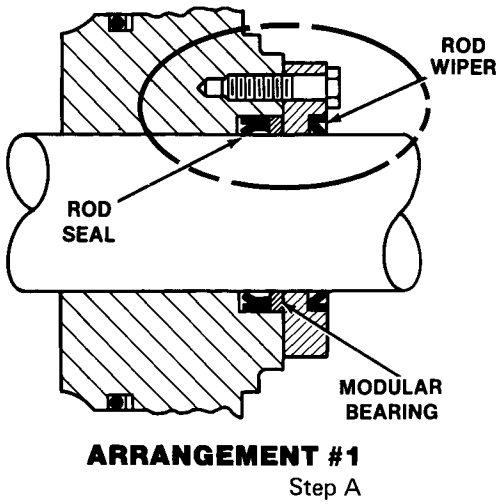

ARRANGEMENT #1

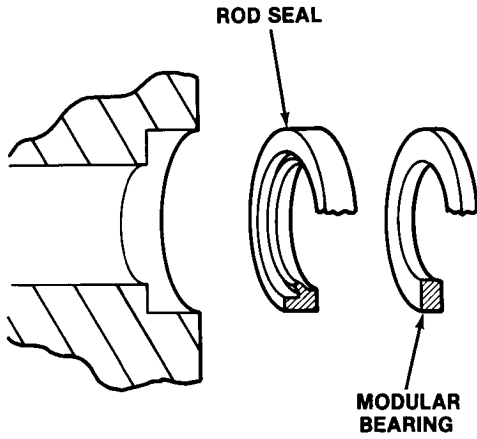

TS-21238

ARRANGEMENT #4

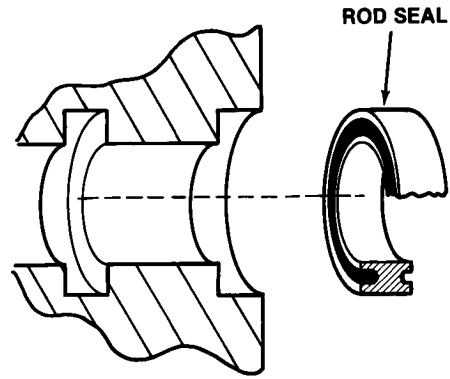

TS-21240

A.

1. Remove and discard the modular bearing.
2. Remove and discard the rod seal.

C.

1. Remove and discard the rod seal.

ARRANGEMENTS #2 & 3

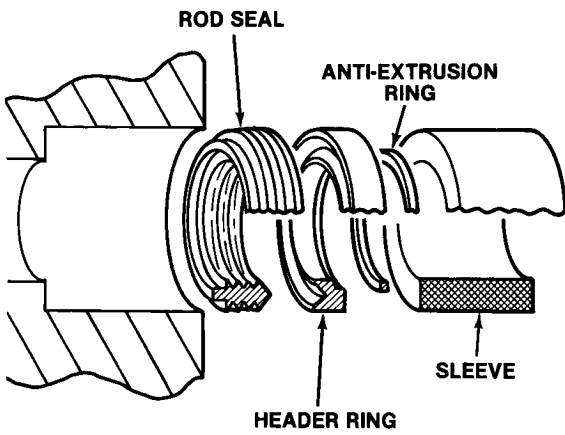

TS-21239

ARRANGEMENTS #5 & 6

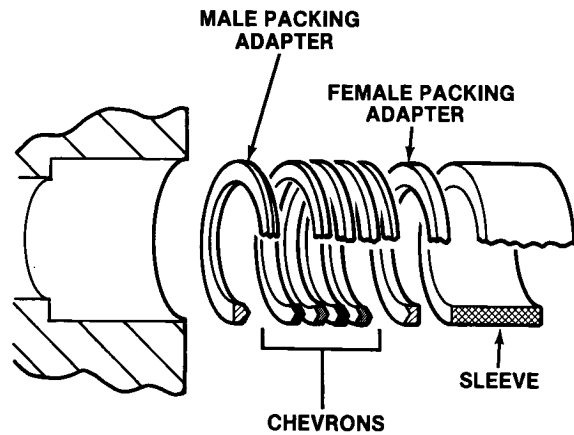

TS-21241

B.

1. Remove the sleeve, if used.
2. Remove and discard the anti-extrusion ring.
3. Remove and discard the header ring.
4. Remove and discard the rod seal.

D.

1. Remove the sleeve, if used.
2. Remove and discard the female packing adapter.
3. Remove and discard the chevrons.
4. Remove and discard the male packing adapter.

ARRANGEMENT #7

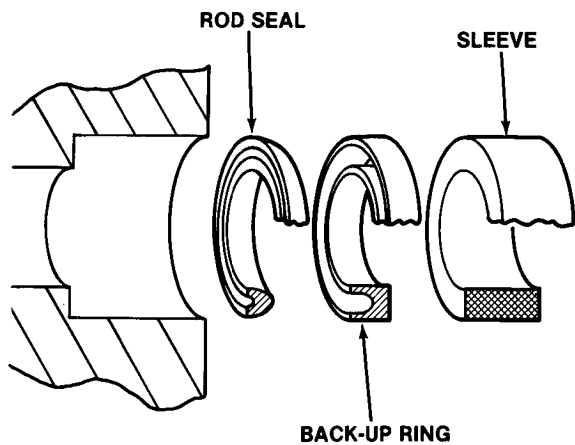

TS-21242

E.

1. Remove the sleeve, if used.
2. Remove and discard the backup ring.
3. Remove and discard the rod seal.

ARRANGEMENT #8

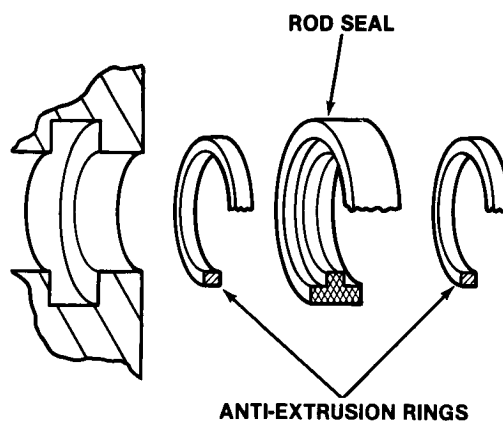

TS-21243

F.

1. Remove and discard the anti-extrusion rings.
2. Remove and discard the rod seal.

7. Remove the buffer ring assembly (if used)

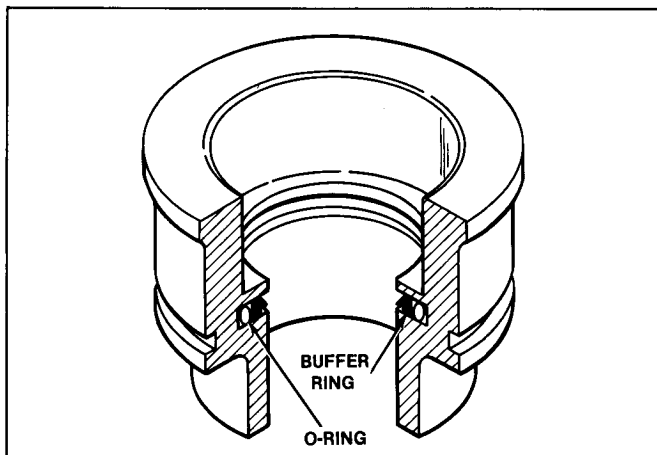

TS-21391

For caps that are fastened in the cylinder by a flange or snap ring. Steps A-B.

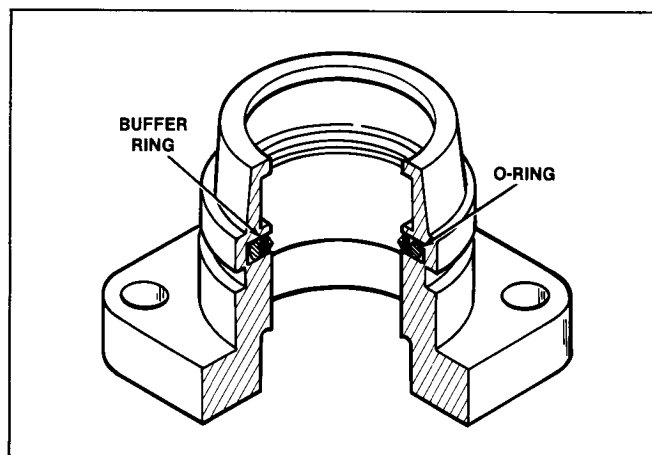

TS-21390

For caps that are fastened to the cylinder with bolts. Steps C-D.

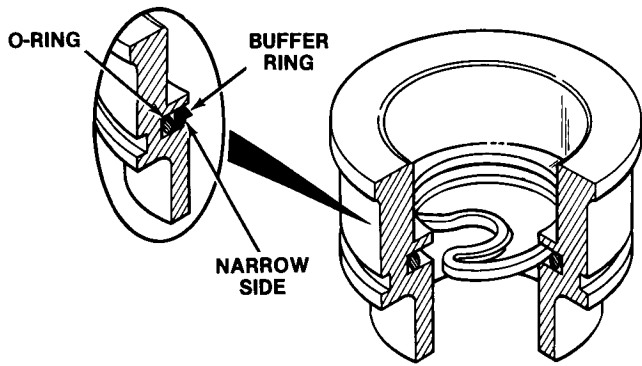

TS-21373

A. Remove and discard the buffer ring.

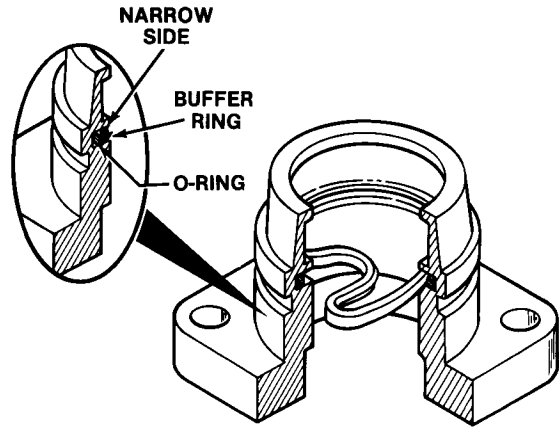

TS-21371

C. Remove and discard the buffer ring.

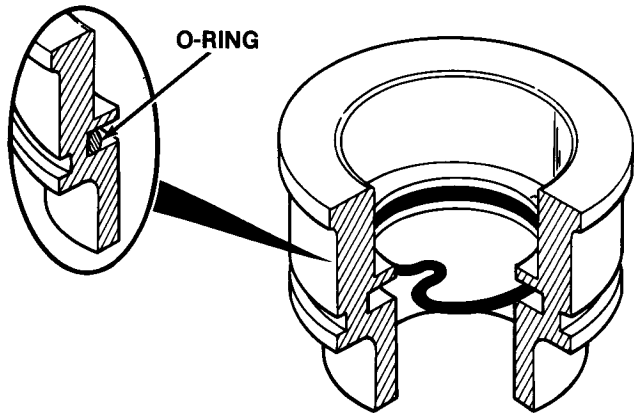

TS-21374

B. Remove and discard the o-ring.

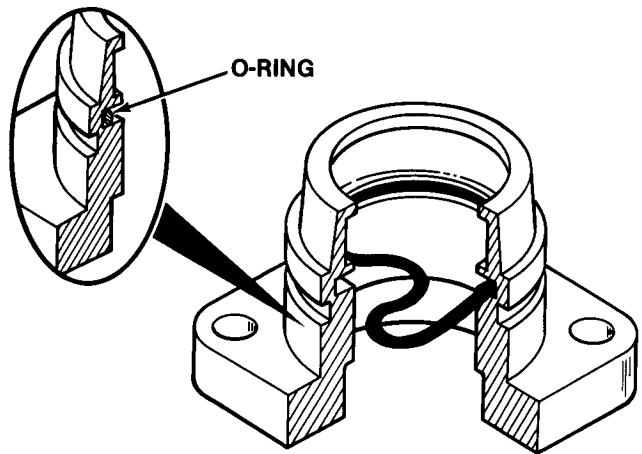

TS-21372

D. Remove and discard the o-ring.

CLEANING AND INSPECTION

Clean all of the parts with solvent and dry.



The solvent can cause skin rashes or fire hazards. Do not inhale the solvent vapors.

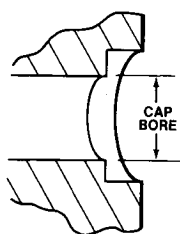

TS-21399

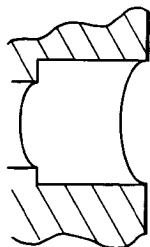

TS-21400

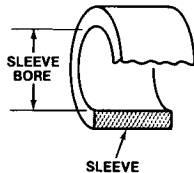

Replace any parts that are damaged or worn. See Supplement 3283 for the original specifications for the cap or sleeve, tube and rod.

Do not install any used sealing parts.

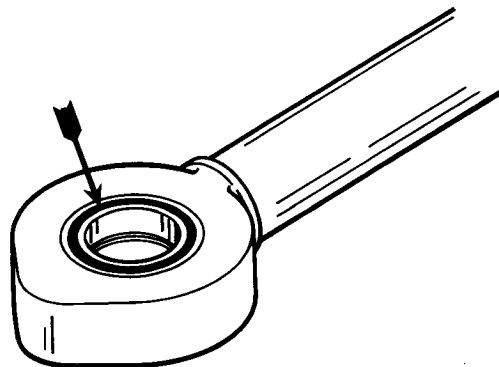

TS-21120

Check the bushing in the piston rod eye and cylinder. Replace the bushing(s) if it has rust, grooves or any distortion.

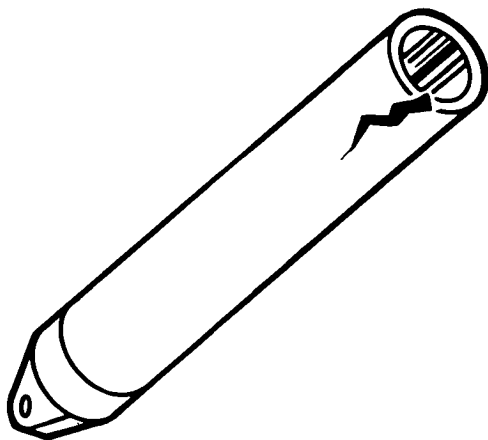

TS-34006

Make sure the cylinder tube is not cracked or scored.

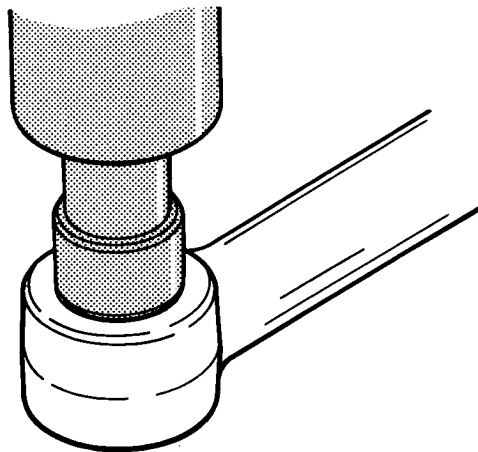

TS-21121

Use a press to push the bushing out of the bore.

Note: Some bushings use snap rings to fasten the bushing, remove if used.

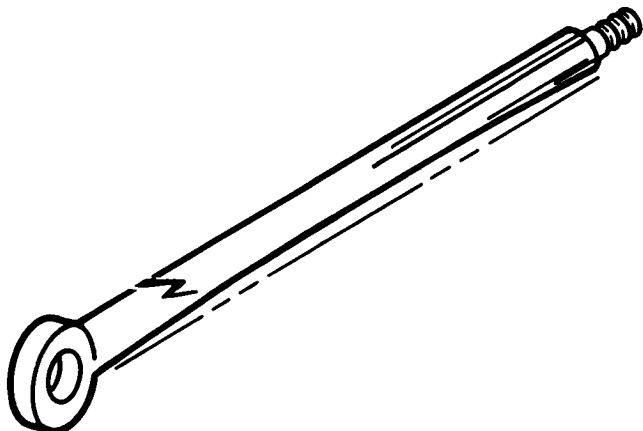

TS-34007

Make sure the cylinder rod is not scored, cracked or bent.

Use a press to push the new bushing into the bore. Center the bushing in the bore. Install snap rings, if used.

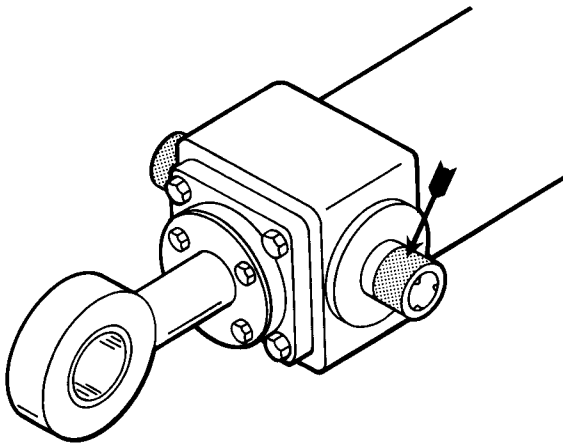

TS-21122

Check the trunnion bushings for rust, grooves or any distortion. If the bushings are to be replaced, grind the weld from the bushings and trunnion. Remove the bushings.

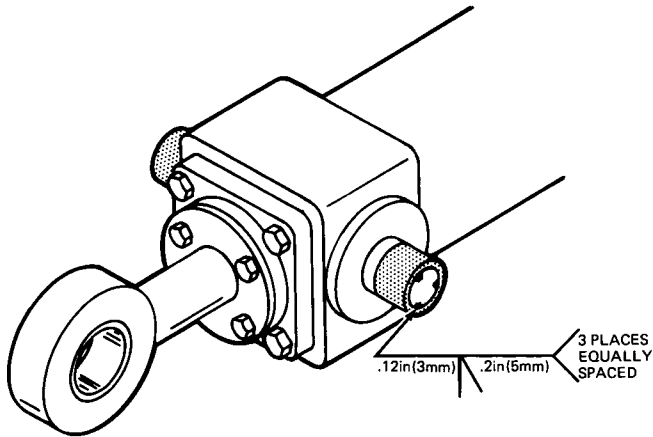

TS-16196

When installing new bushings, use a grinder to remove all of the old weld.

Clean the area of repair, removing all grease, oil, rust, scale and paint from the surfaces to be joined.

Install the bushing. Be sure to protect the bushing surface from weld splatter and damage.

If the cylinder is on the machine, disconnect the battery ground cable before welding.

Weld the bushing in position using .125 inch diameter AWS E-7018 or equivalent with Metal Arc process in accordance with the specifications on the illustration.

Note: *Welder shall be qualified for the type of weld being made in accordance with AWS D14.3 (Latest Issue). Quality and workmanship of weld shall be in accordance with AWS D14.3 (Latest Issue).*



Faulty welding or improper installation could cause property damage, personal injury or death.

ASSEMBLY

1. Install the buffer ring assembly.

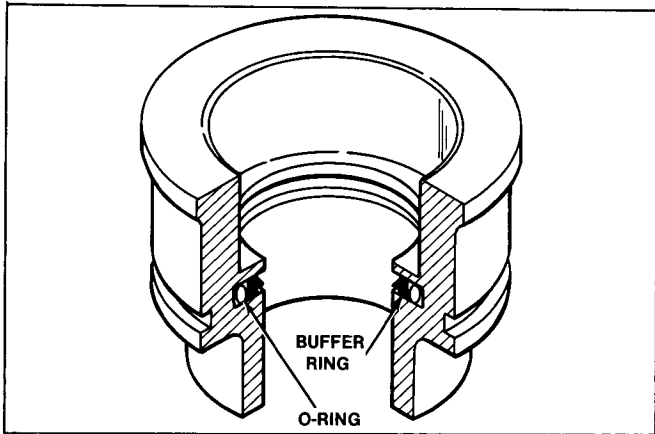

TS-21391

For caps that are fastened in the cylinder by a flange or snap ring. Steps A-C.

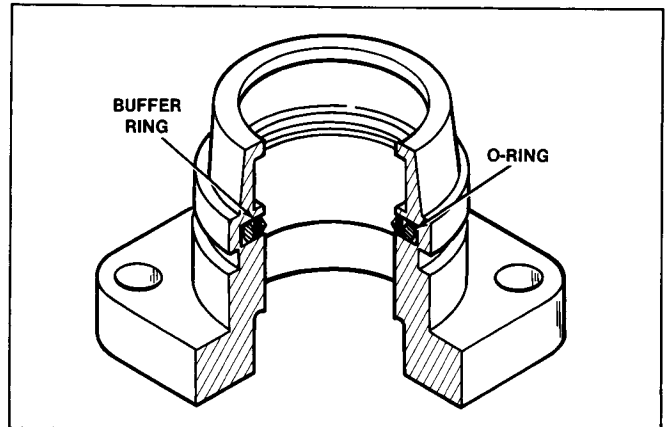

TS-21390

For caps that are fastened to the cylinder with bolts. Steps D-F.

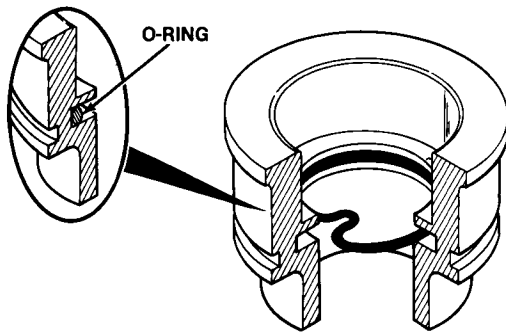

TS-21374

A. Apply hydraulic fluid to the o-ring. Install the o-ring.

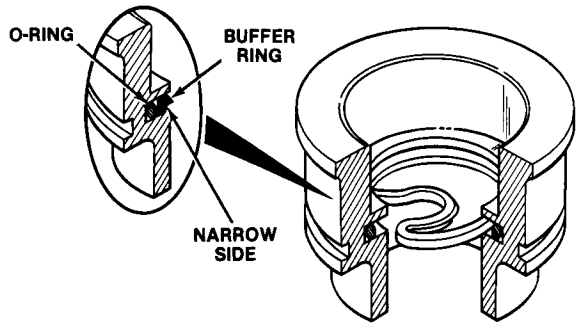

TS-21373

C. Install the buffer ring.

Note: Be sure the buffer ring is installed correctly, with the narrow side toward the inside of the cylinder. Carefully smooth the ring fully into the groove. See the illustration above.

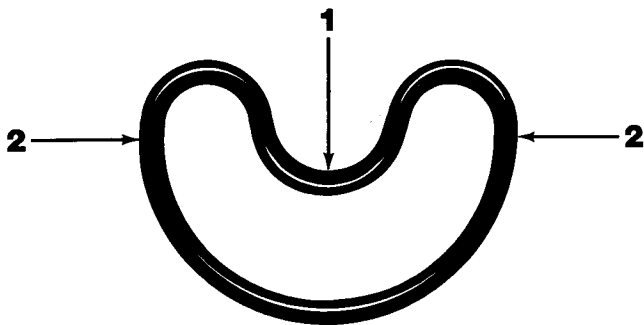

TS-21398

B. Apply hydraulic fluid to the buffer ring. Push the top (1) of the buffer ring down while holding the sides (2). Push the sides (2) together until the ring will slide into the bore.

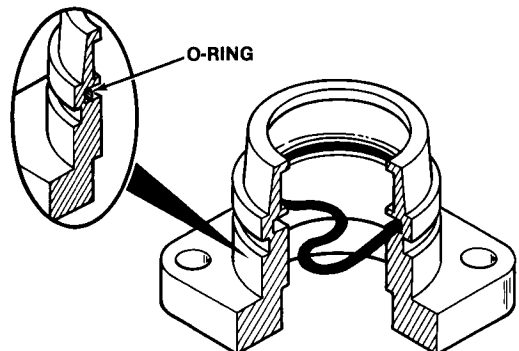

TS-21372

D. Apply hydraulic fluid to the o-ring. Install the o-ring.

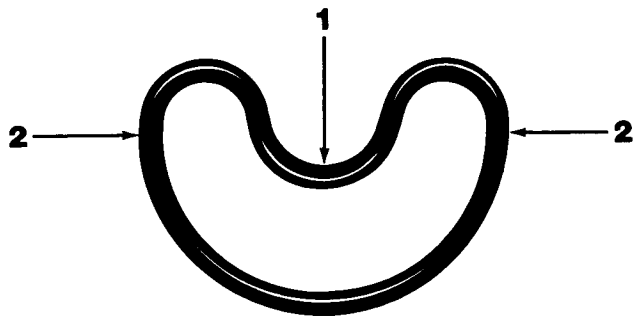

TS-21398

E. Apply hydraulic fluid to the buffer ring. Push the top (1) of the buffer ring down while holding the sides (2). Push the sides (2) together until the ring will slide into the bore.

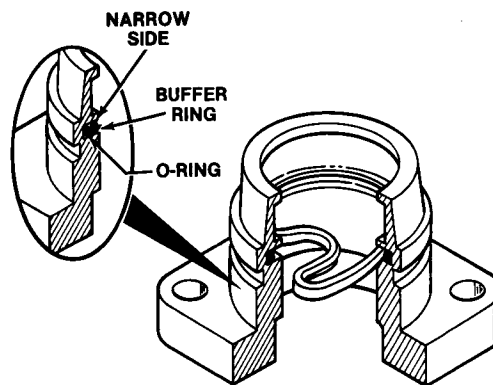

TS-21371

F. Install the buffer ring.

Note: Be sure the buffer ring is installed correctly, with the narrow side toward the inside of the cylinder. Carefully smooth the ring fully into the groove. See the illustration above.

2. Install the rod seal.

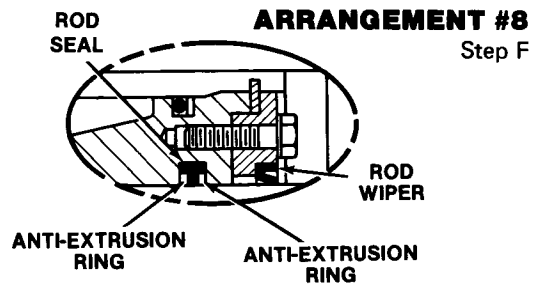
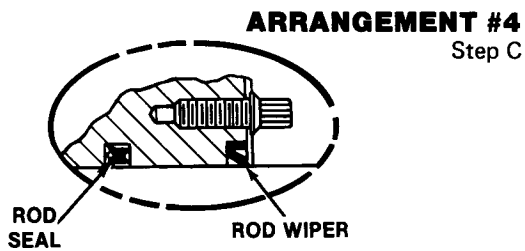
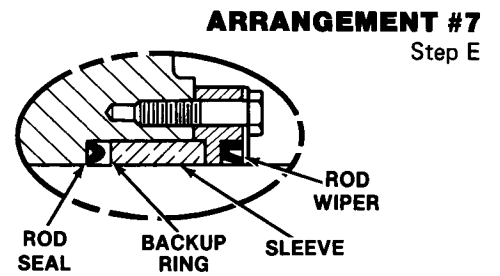
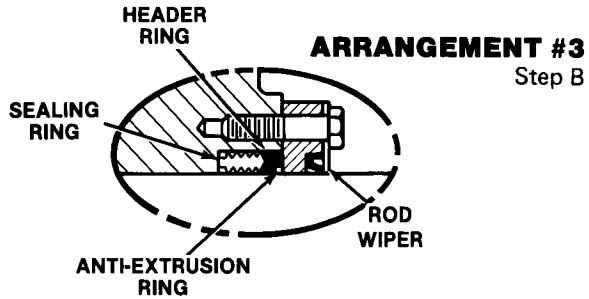
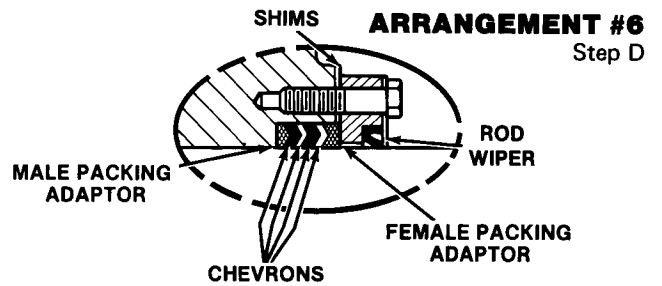
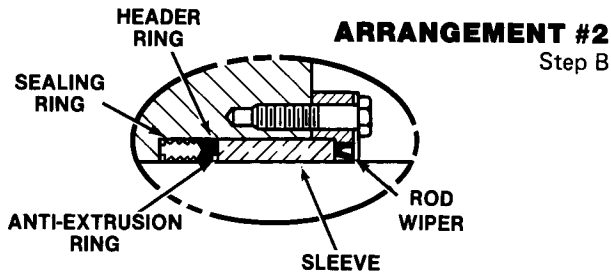
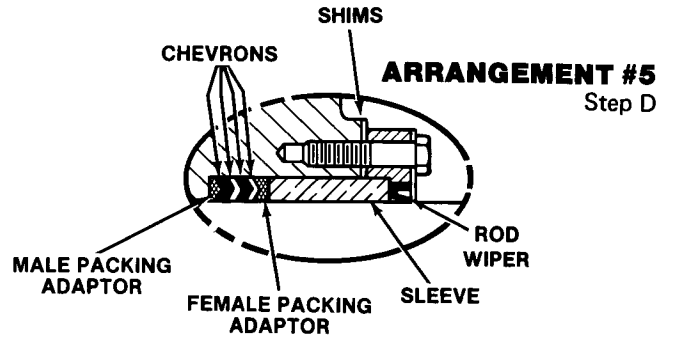
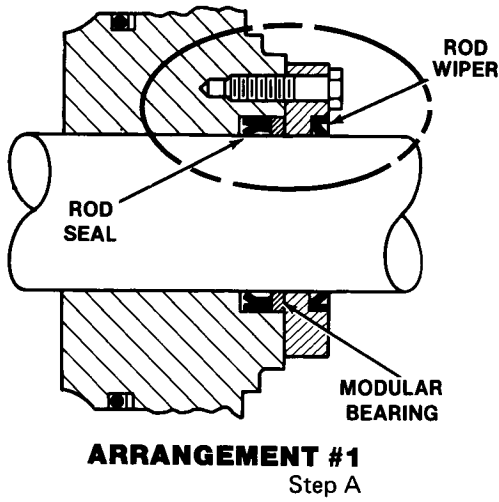

ARRANGEMENT #1

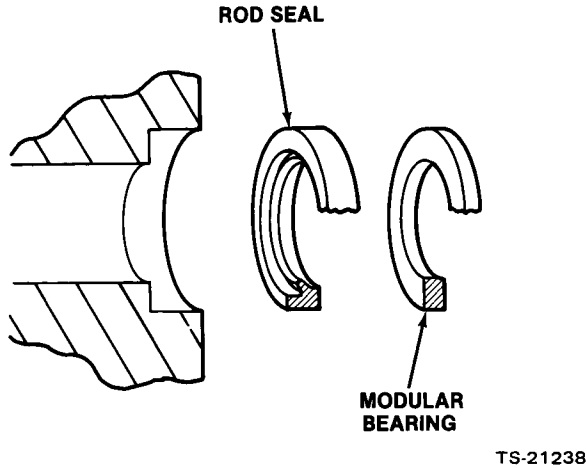

A.

1. Apply hydraulic fluid to the rod seal and install with the lips toward the pressure.
2. Apply hydraulic fluid to the modular bearing and install it.

ARRANGEMENT #4

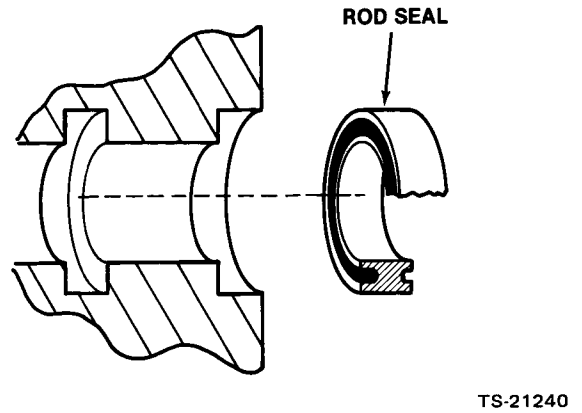

C.

1. Apply hydraulic fluid to the seal assembly and install with the lips toward the pressure.

ARRANGEMENTS #2 & 3

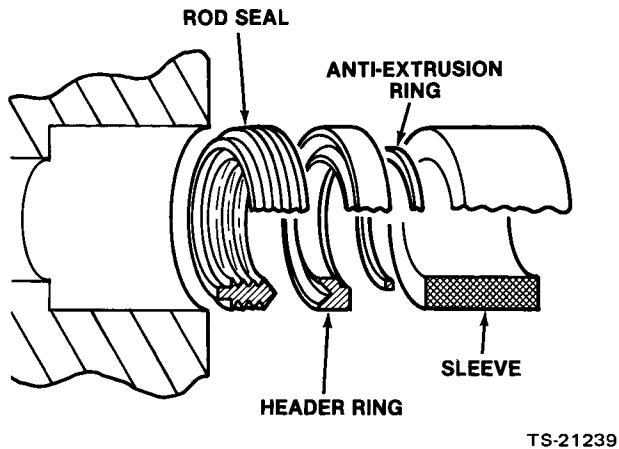

B.

1. Apply hydraulic fluid to all three parts of the seal assembly.

Note: The seal assembly will be installed with the splits in the rings turned 180° from the last ring installed, to help prevent leakage.

2. Install the rod seal.
3. Install the header ring.
4. Install the anti-extrusion ring.
5. Install the sleeve, if used.

ARRANGEMENTS #5 & 6

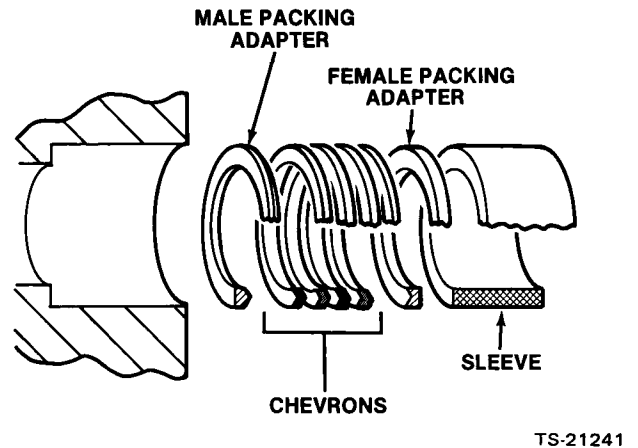

D.

1. Apply hydraulic fluid to the seal assembly.

Note: Do not cut the seal assembly unless the seal is to be changed while the cylinder is on the machine. If the seal is to be changed on the machine, cut the seals at a 45° angle and install with the splits 180° from the last ring installed, to help prevent leaks.

2. Install the male packing adapter.
3. Install the chevrons.
4. Install the female packing adapter.
5. Install the sleeve, if used.

ARRANGEMENT #7

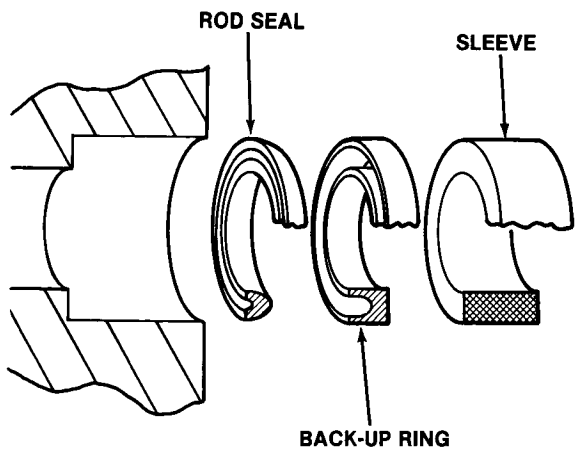

TS-21242

E.

1. Apply hydraulic fluid to the seal assembly.
2. Install the rod seal.
3. Install the backup ring.
4. Install the sleeve.

ARRANGEMENT #8

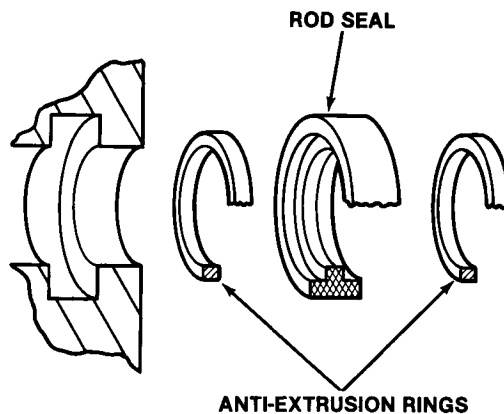

TS-21243

F.

1. Apply hydraulic fluid to the seal assembly.
2. Install the seal in the packing groove. Be sure the seal is flat in the groove.
3. Install the anti-extrusion rings. Be sure the splits are not together and the rings lie flat.

3. Assemble the cap.

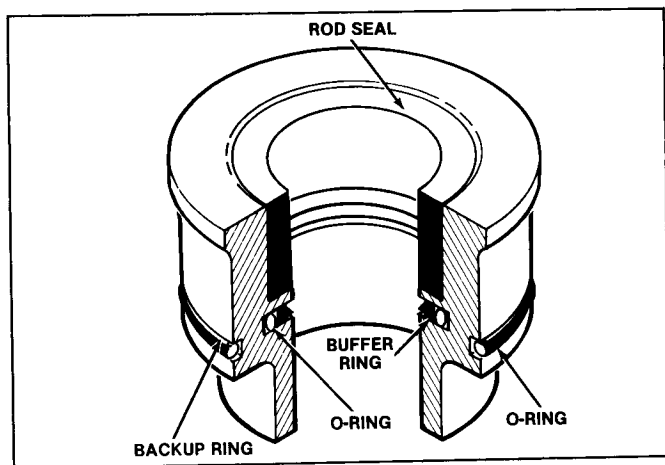

TS-21181

For caps that are fastened in the cylinder by a snap ring or flange with threads. Steps A-D.

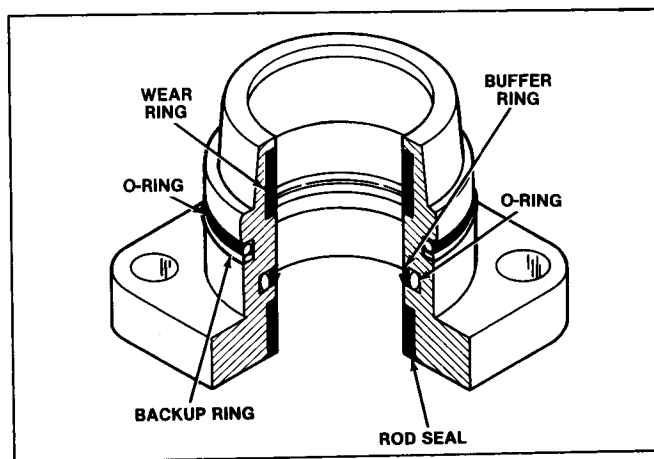

TS-21182

For caps that are fastened to the cylinder by bolts. Steps E-L.

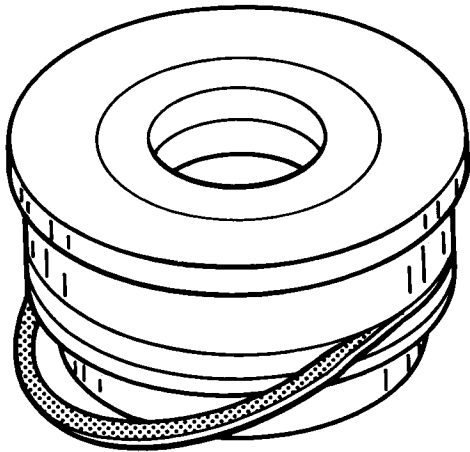

TS-21119

A. Apply grease to the backup ring and install it on the cap.

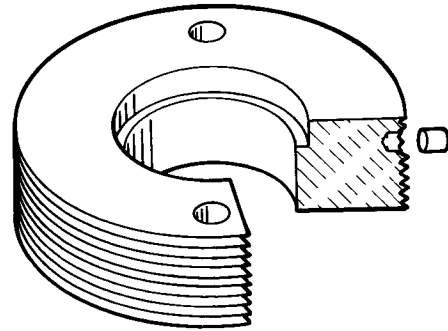

TS-16282

D. Apply grease to the plug, if used. Install the plug in the flange.

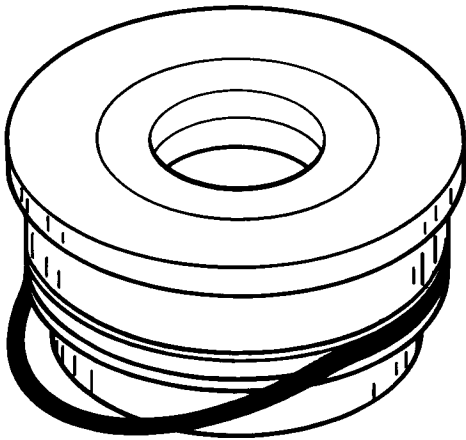

TS-21118

B. Apply grease to the o-ring and install it on the cap.

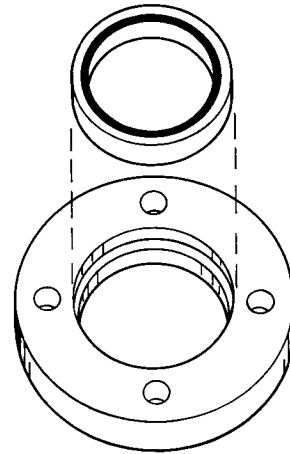

TS-21194

E. Apply grease to the rod wiper and install in the flange.

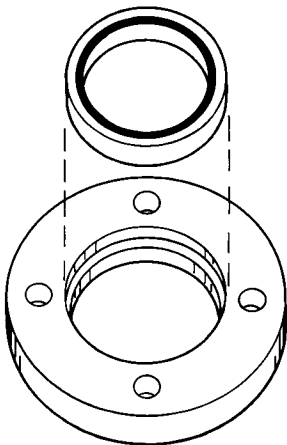

TS-21194

C. Apply grease to the rod wiper and install in the flange.

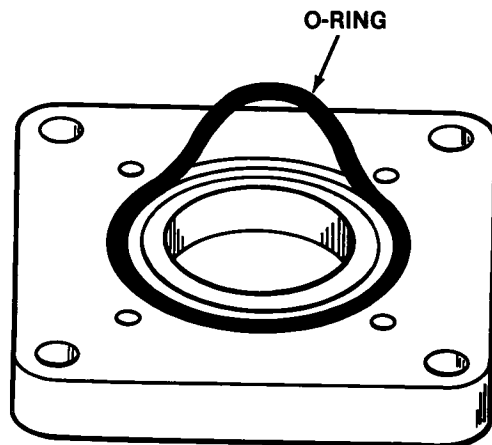

TS-21375

F. Apply hydraulic fluid to the o-ring, if used. Install the o-ring.

Note: Some cylinders have the wiper located in the cap. Apply grease to the wiper and install it.

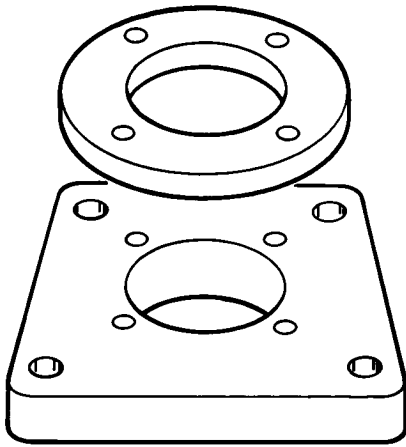

TS-21167

G. Install two shims on the cap, if used. Be sure to align the bolt holes. Install the flange on the cap. Be sure to align the bolt holes.

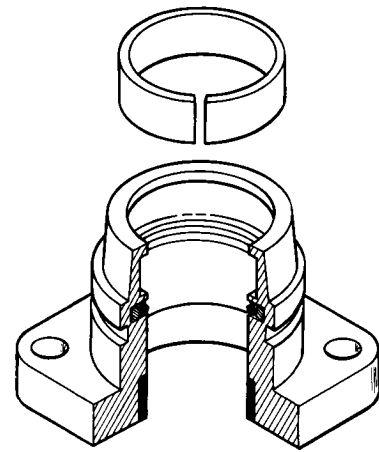

TS-21370

J. Apply hydraulic fluid to the wear ring, if used. Install the wear ring.

Note: To install the ring in the groove, the ring must be compressed. To compress the ring, put one of the split ends of the ring inside of the other and push the ring together.

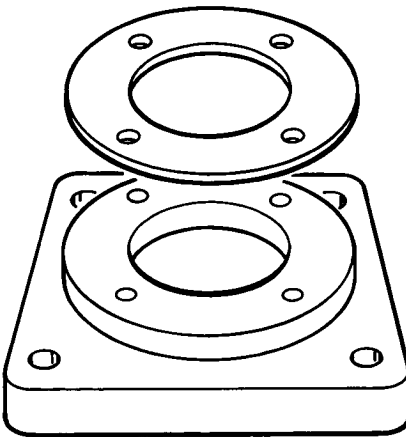

TS-21113

H. Install the retainer ring on the flange. Be sure to align the bolt holes.

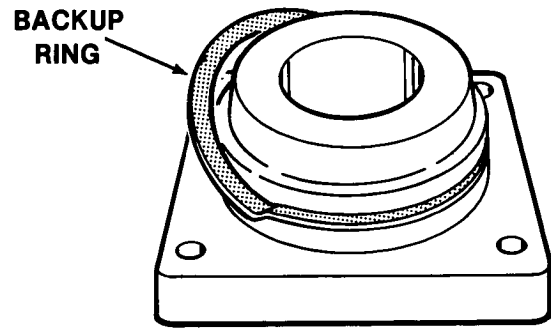

TS-21168

K. Apply grease to the backup ring and install.

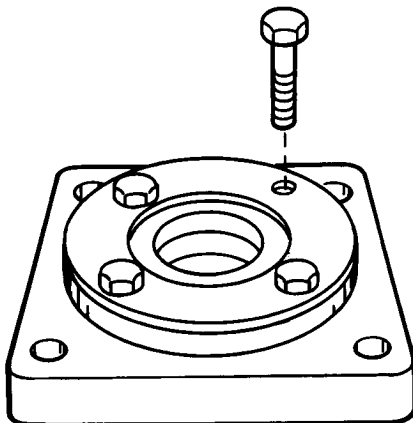

TS-21112

I. Install the retainer bolts. Do not tighten the bolts, they must be loose.

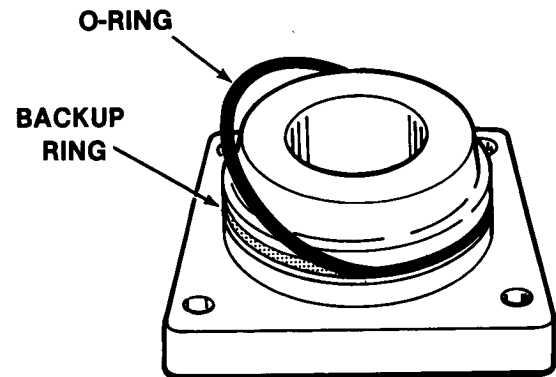

TS-21115

L. Apply grease to the o-ring and install.

4. Assembly of the piston.

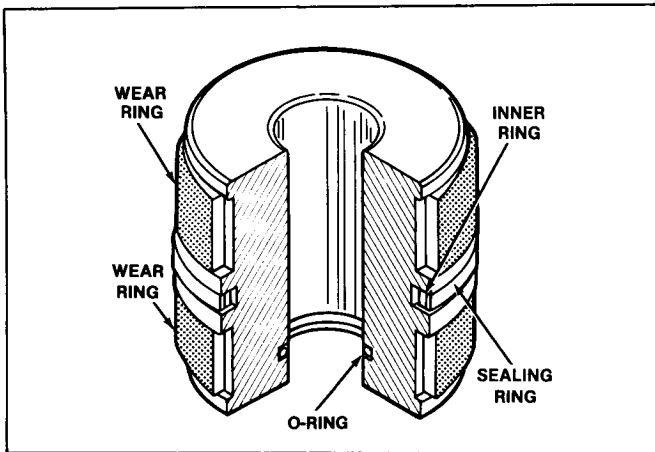

TS-21179

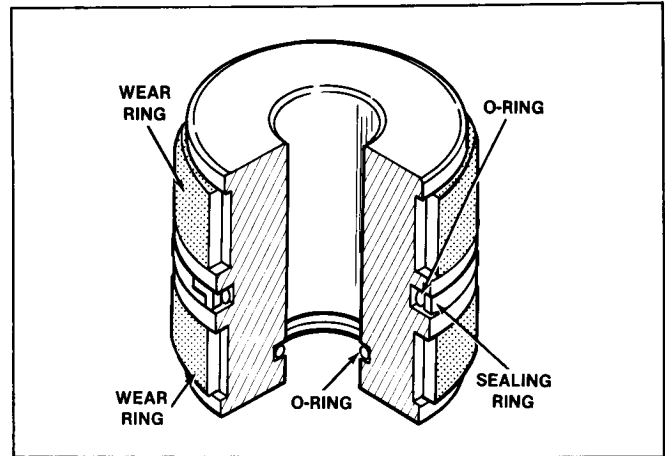

TS-21388

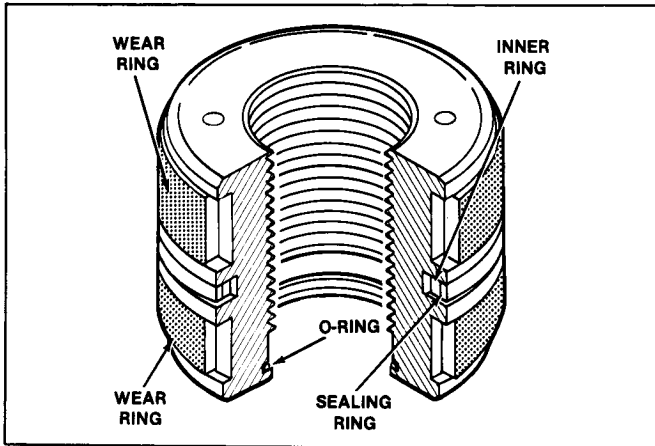

TS-21180

For pistons with no split in the sealing ring. Steps A-D.

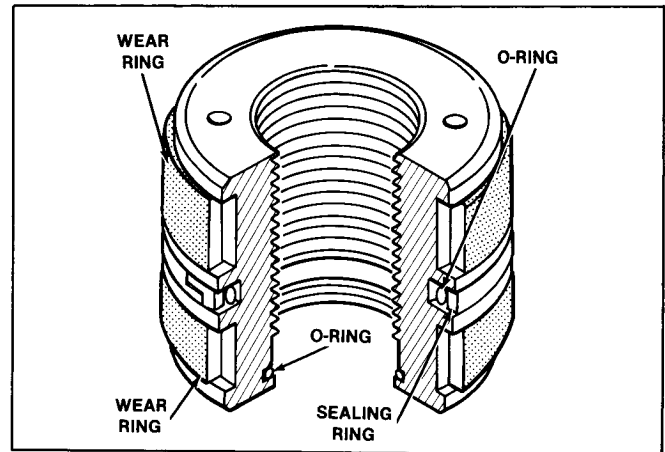

TS-21389

For pistons with a split piston sealing ring. Steps E-H.

Note: If the piston has two seal rings, follow the same assembly procedure except install both sets of rings.

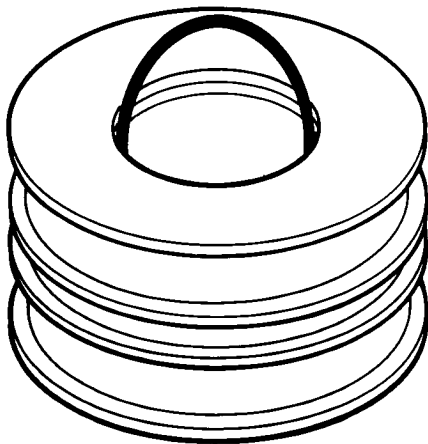

TS-21111

A. Apply grease to the o-ring and install in the groove inside the piston.

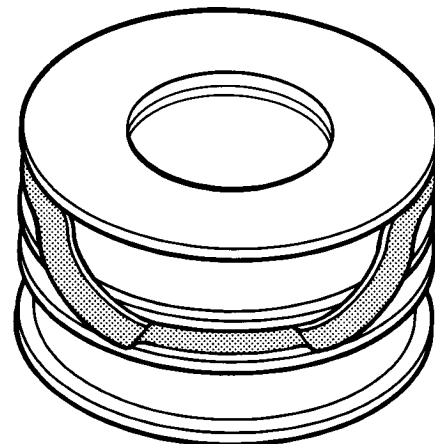

TS-21110

B. Install a new inner ring in the center groove of the piston.

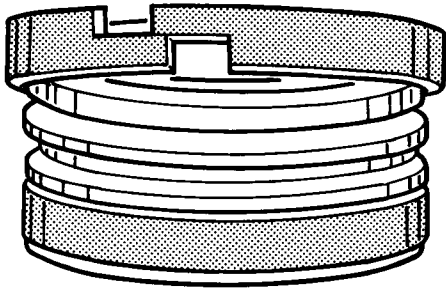

TS-21195

C. Install new wear rings on the piston. Be sure there is 180° between the splits of the rings.

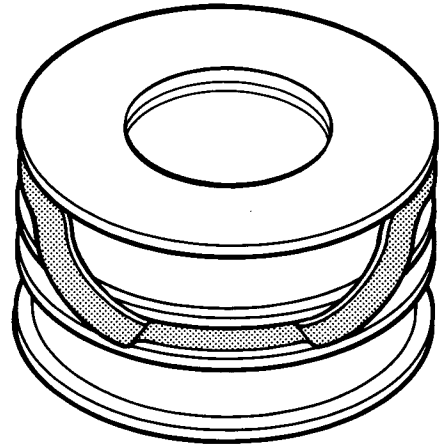

TS-21110

F. Install a new o-ring in the center groove of the piston.

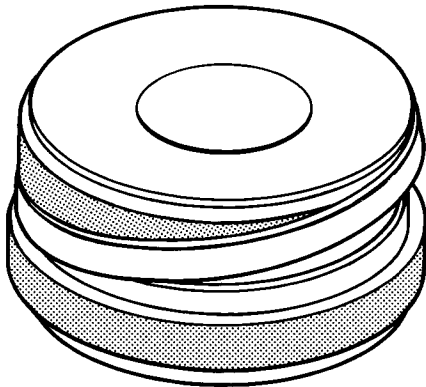

TS-21196

D. Install a new outer seal ring in the center groove of the piston.

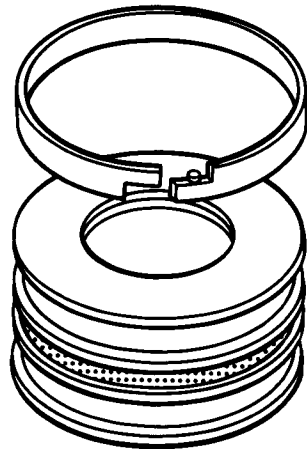

TS-21376

G. Install a new seal ring in the center groove of the piston.

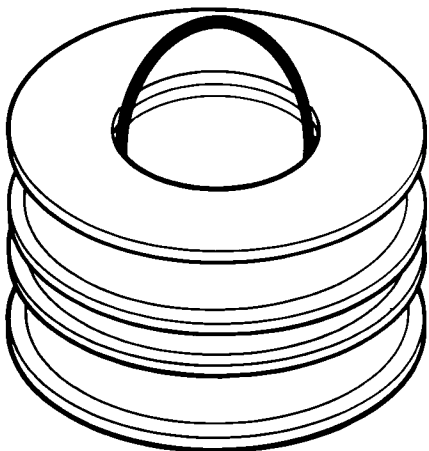

TS-21111

E. Apply grease to the new o-ring and install in the groove inside the piston.

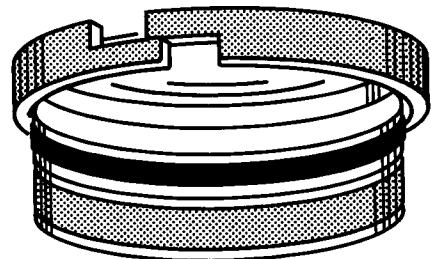

TS-21397

H. Install new wear rings on the piston. Be sure there is 180° between the splits of the rings.

5. Install the cap on the piston rod.

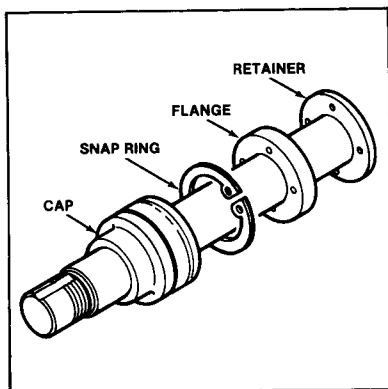

TS-21177

For caps fastened by a snap ring. Steps A-E.

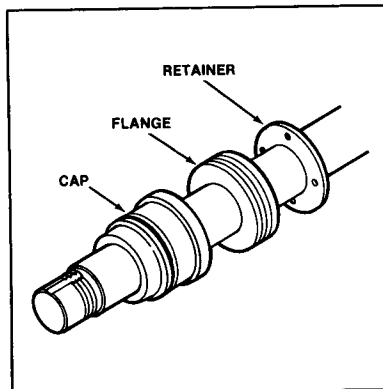

TS-21176

For caps fastened by a flange with threads. Steps F-H.

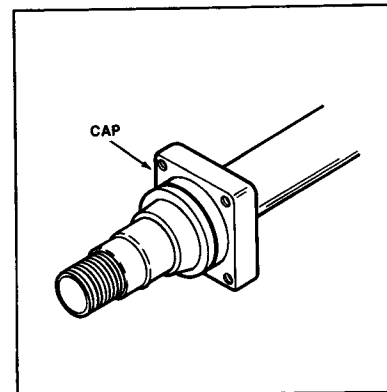

TS-21178

For caps that are fastened by bolts. Steps I-L.

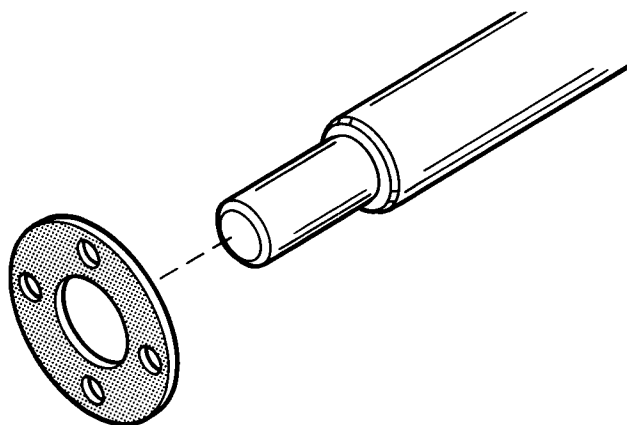

TS-21088

A. Apply grease to the inside of the retainer ring and install it on the rod.

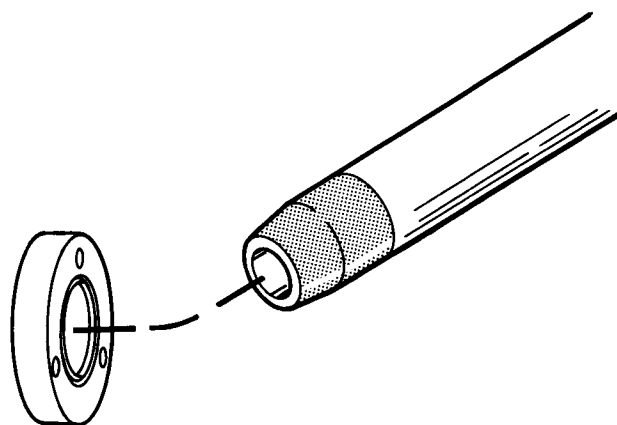

TS-21123

C. Apply hydraulic fluid to the inside of the flange and install it on the rod, with the wiper toward the rod eye.

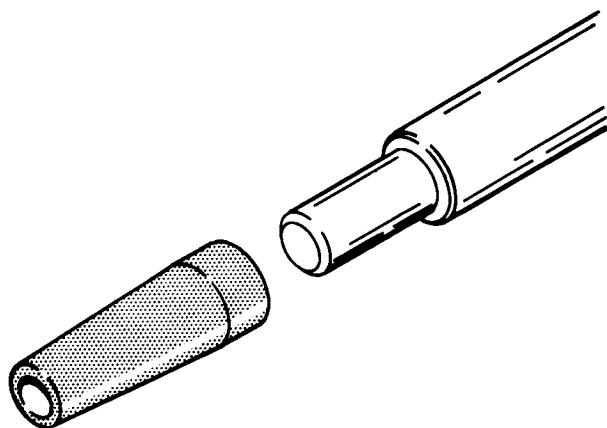

TS-16195

B. Apply grease to the inside of the seal guide and install it on the end of the rod. Apply hydraulic fluid to the outside of the seal guide.

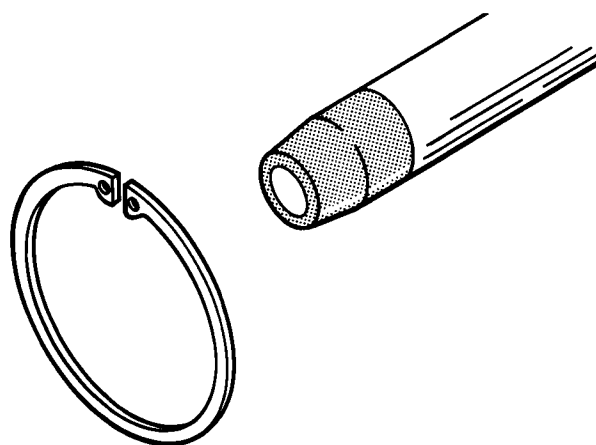

TS-21185

D. Install the snap ring on the rod.

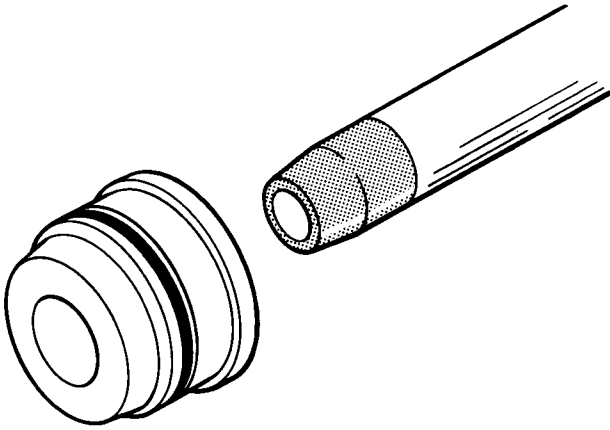

TS-21124

E. Apply hydraulic fluid inside the cap and install it on the rod. Remove the seal guide.

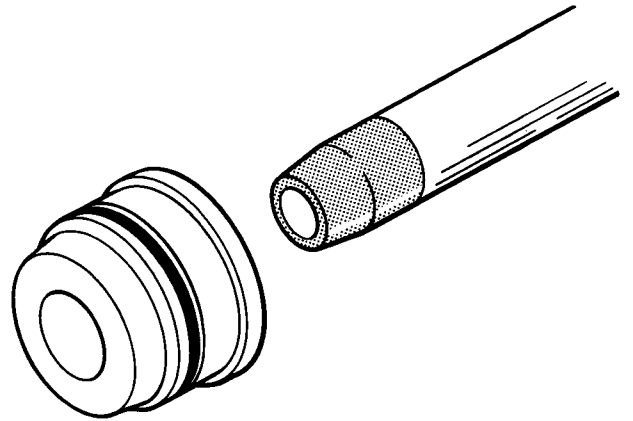

TS-21124

H. Apply hydraulic fluid to the inside of the cap and install it on the rod. Remove the seal guide.

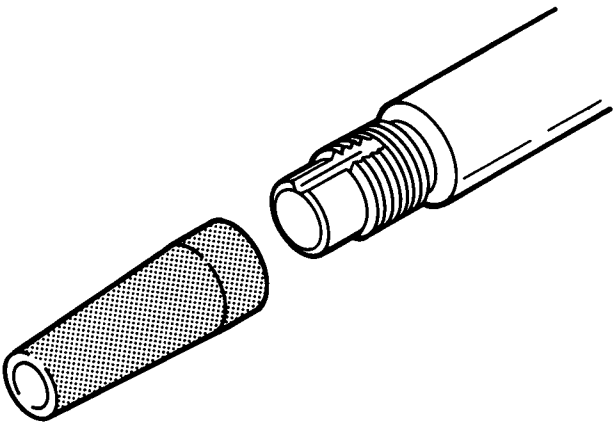

TS-21432

F. Apply grease to the inside of the seal guide and install it on the end of the rod. Apply hydraulic fluid to the outside of the seal guide.

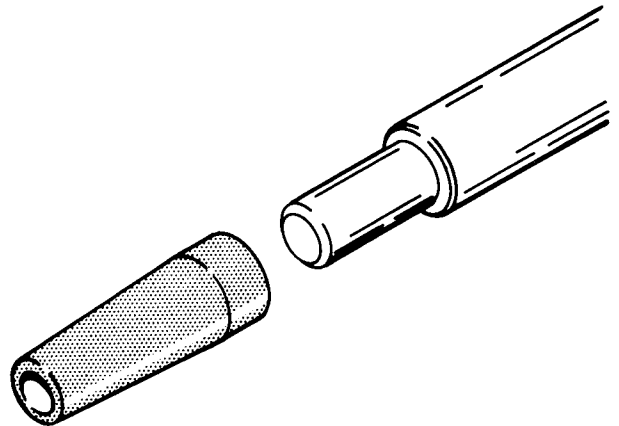

TS-16195

I. Apply grease to the inside of the seal guide and install it on the end of the rod. Apply hydraulic fluid to the outside of the seal guide.

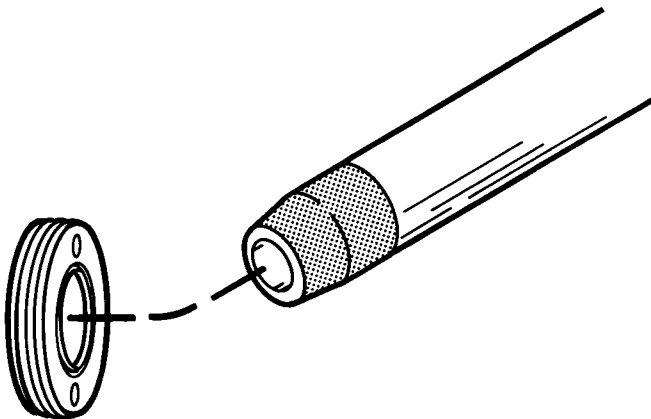

TS-21433

G. Apply hydraulic fluid to the inside of the flange and install it on the rod, with the wiper facing the rod eye.

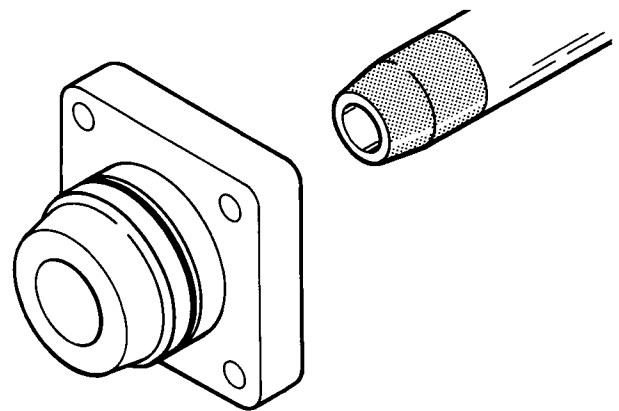

TS-21125

J. Apply hydraulic fluid to the inside of the cap assembly and install it on the rod.

K. Tighten the retainer bolts to the correct torque (see Supplement 3283).

Note: If seal arrangement #5 or 6 are used, the cap must fit tight on the rod and be able to turn with some resistance.

If the cap turns with very little resistance, loosen the bolts and remove shims until the cap turns with some resistance. Tighten the bolts to the correct torque.

If the cap turns with a large amount of resistance, loosen the bolts and add shims until the cap turns with some resistance. Cut the shims on an angle and be sure the cuts are not next to each other when installed. Tighten the bolts to the correct torque.

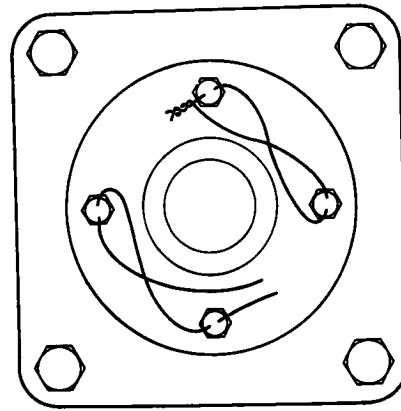

TS-21165

L. Install the lockwires, if used.

6. Install the piston on the rod.

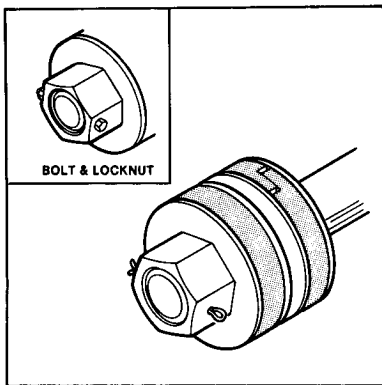

TS-21173

For pistons fastened on by a nut held by a cotter pin or a bolt and nut. Steps A-C.

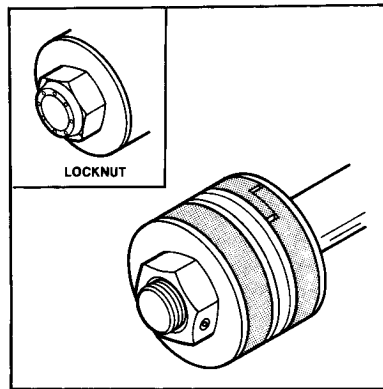

TS-21174

For pistons fastened on by a nut held by a set screw or a locknut. Steps D-F.

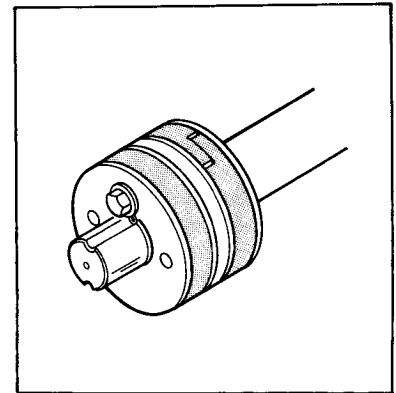

TS-21175

For pistons that have threads inside. Steps G-J.

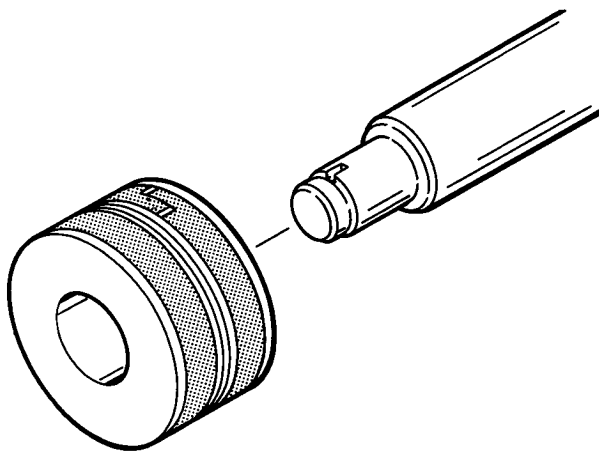

TS-21105

A. Apply grease to the inside of the piston. If the o-ring groove is located in the rod, apply grease to the o-ring and install it. Install the piston on the rod. Be sure not to damage the o-ring.

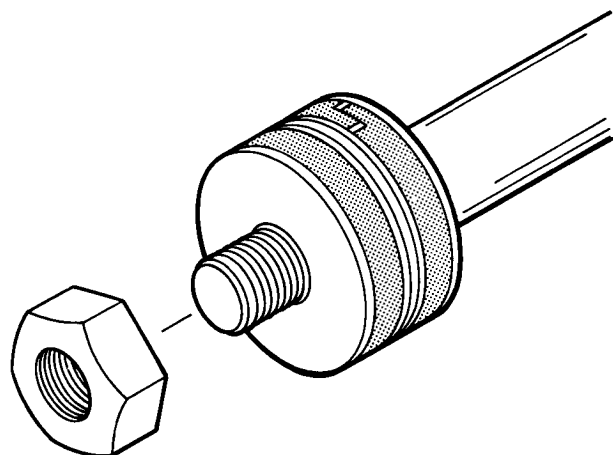

TS-21104

B. Install the nut on the rod. Tighten the nut to the correct torque (see Supplement 3283).

See if the holes in the nut are aligned with the hole in the rod. If the holes are not aligned, remove the nut.

Start the other end of the nut on the rod. Tighten the nut to the correct torque. See if the holes in the nut are aligned with the hole in the rod. If the holes cannot be aligned, a hole can be drilled in the rod.

NOTE: *The rod can have no more than two holes through it.*

Use the holes in the nut as a drill guide. Do not use the holes that are closest to the piston.

Drill a hole halfway through the rod, finish drilling the hole from the opposite side.

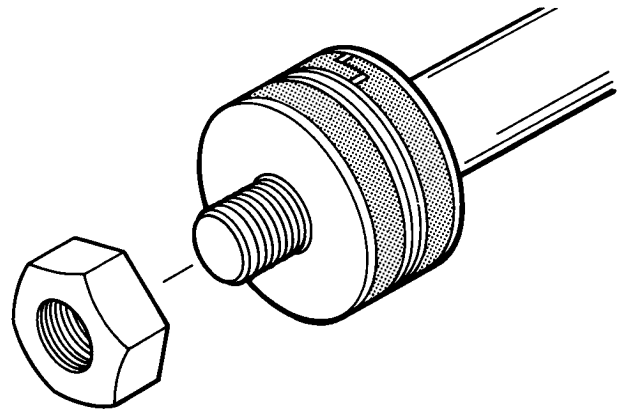

TS-21104

E. Install the nut on the rod and tighten to the correct torque (see Supplement 3283).

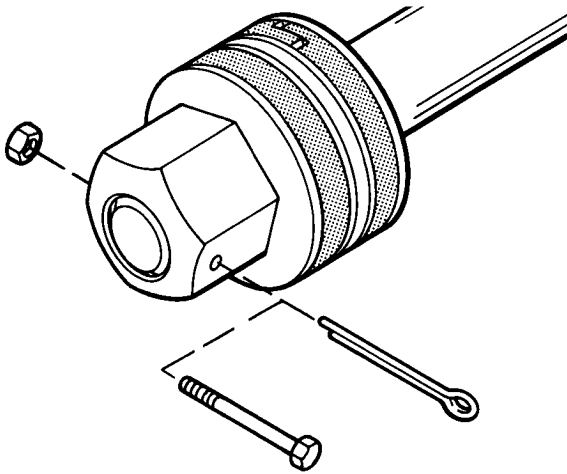

TS-21103

C. Install the cotter pin or the nut and bolt. Tighten the nut on the bolt.

Use a hammer to expand the end of the bolt threads to prevent the nut from coming off.

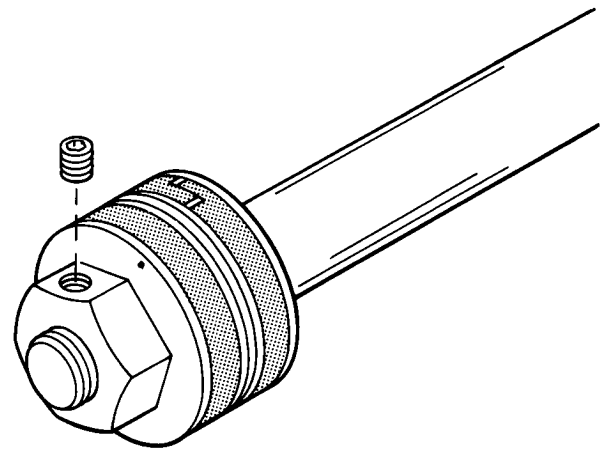

TS-21090

F. Install the set screw(s), if used, and tighten.

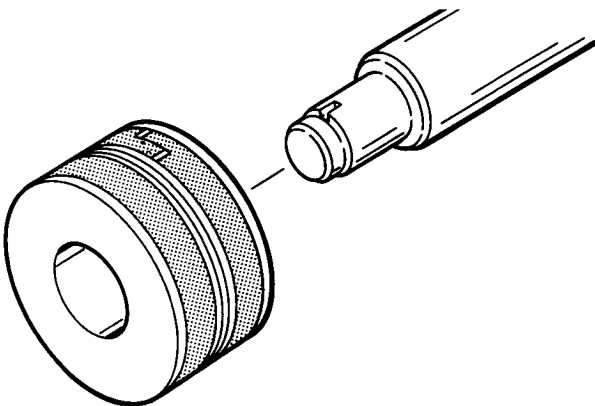

TS-21105

D. Apply grease to the inside of the piston. If the o-ring groove is located in the rod, apply grease to the o-ring and install it. Install the piston on the rod. Be sure not to damage the o-ring.

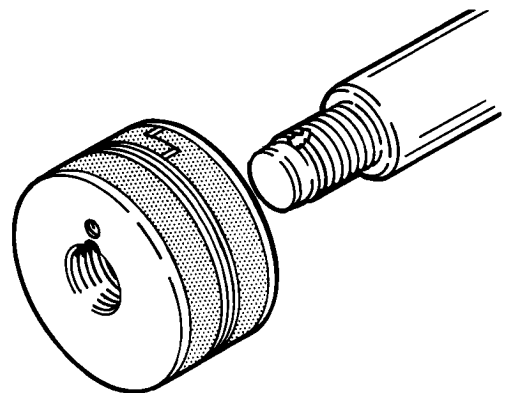

TS-16244

G. Apply grease to the inside of the piston and install the piston. Be sure not to damage the o-ring.

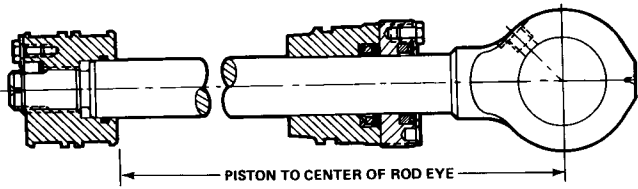

TS-16232

H. Turn the piston to the dimension measured in "Disassembly - Remove the piston from the rod assembly" (G). If this dimension was not measured, or if a new rod or piston is used, turn the piston to the correct measurement (see Supplement 3283). Turn the piston the shortest distance to align the groove in the piston and the rod.

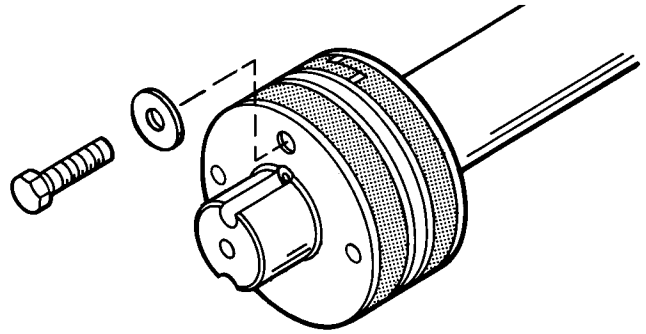

TS-21101

J. Install the bolt and washer in the piston. Tighten the bolt to the correct torque (see Supplement 3283).

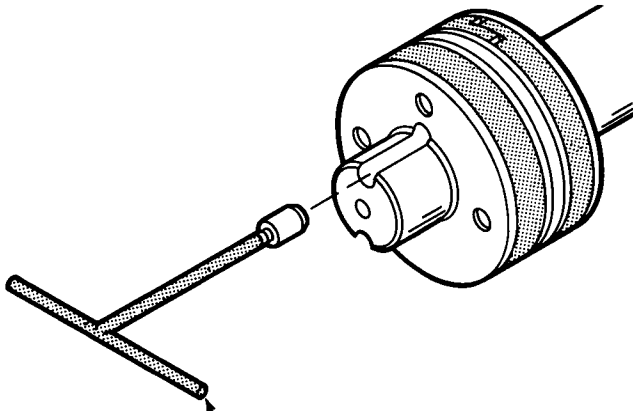

DOWEL PIN PULLER

TS-21102

I. Install the dowel pin in the piston. Remove the dowel pin puller.

7. Install the rod assembly into the cylinder.

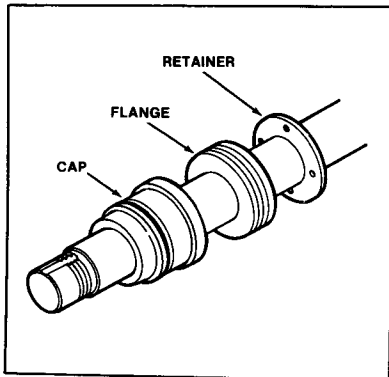

TS-21176

For cylinders with the cap fastened by a flange with threads. Steps A-H.

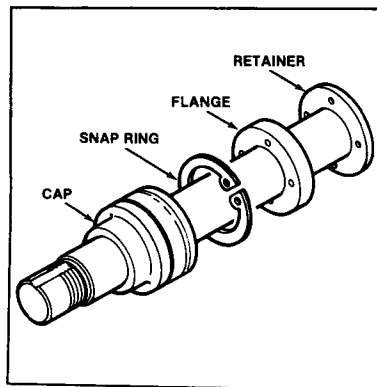

TS-21177

For cylinders with the retainer fastened by bolts and the cap fastened by a snap ring. Steps I-N.

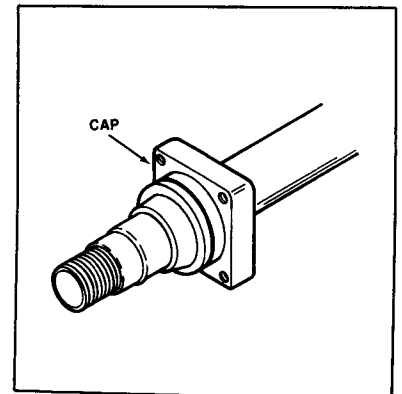

TS-21178

For cylinders with a cap that is bolted on. Steps O-R.

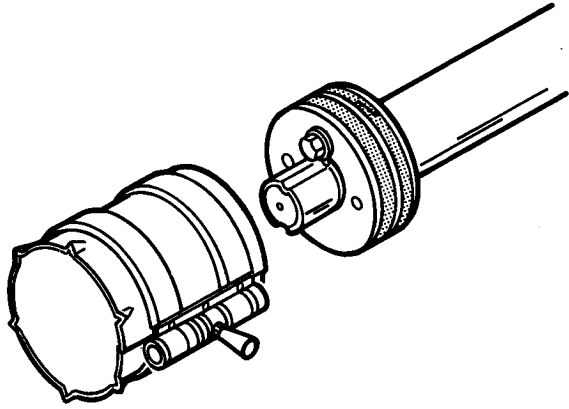

TS-21209

A. Apply grease to the outside of the piston. Install a ring compressor on the piston and tighten it.

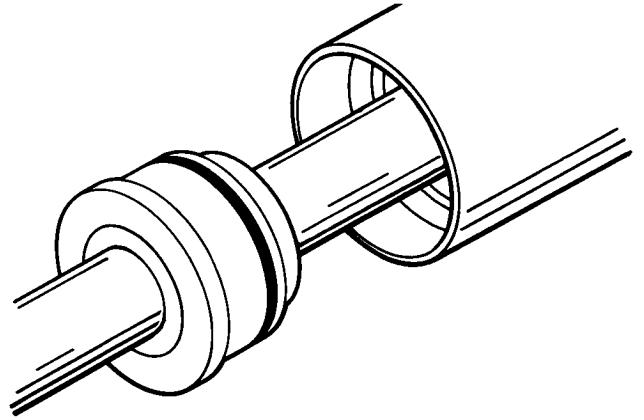

TS-21099

D. Install the cap into the cylinder. Be sure not to damage the o-ring or backup ring.

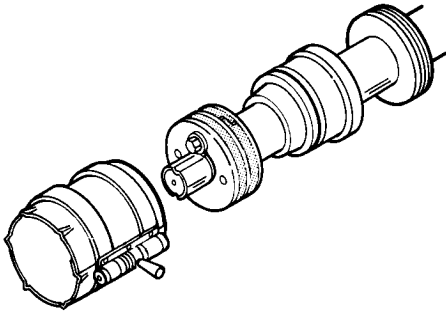

TS-21210

B. Apply grease to the outside of the cap and flange. Remove ring compressor.

Install a piece of .005 in (1,27 mm) shim stock, long and wide enough to cover the cylinder port.

Be sure the shim stock is long enough to be held so that it will not slide into the cylinder as the piston is pushed in.

NOTE: Make sure the wear ring splits are 180° apart.

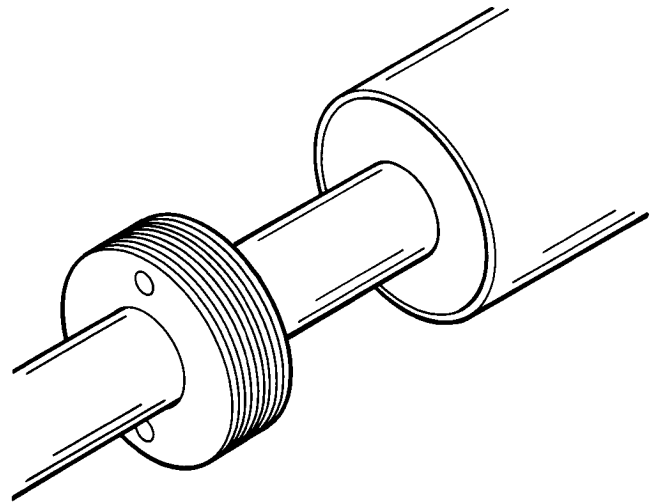

TS-21093

E. Install the flange in the cylinder.

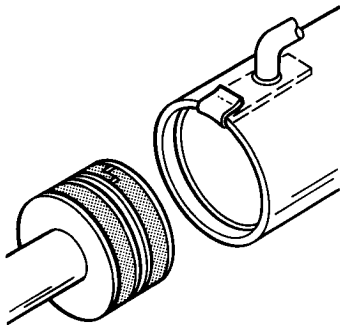

TS-21320

C. Install the piston into the cylinder. Be sure not to damage the wear rings or sealing ring.

Remove the shim stock.

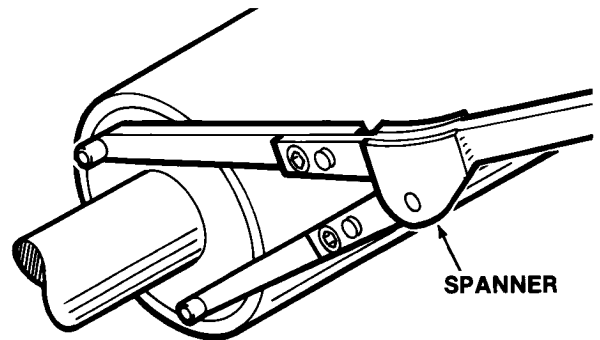

TS-21092

F. Turn the flange until it is tight.

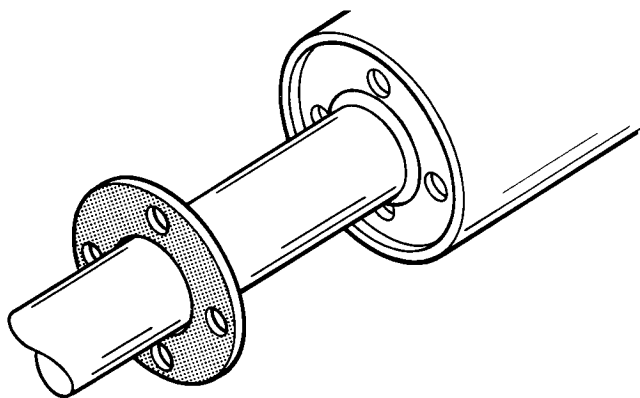

TS-21087

G. Move the retainer, if used, to the flange. Align the bolt holes.

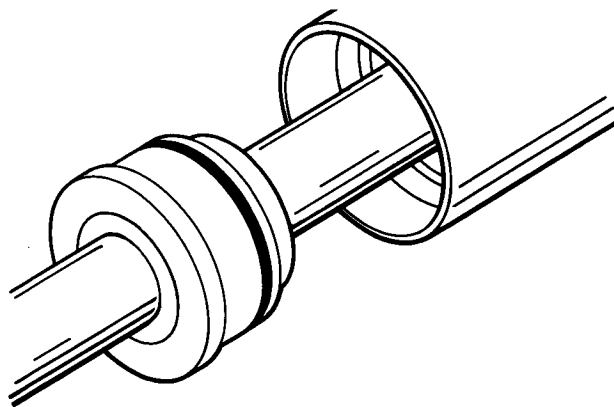

TS-21099

J. Apply grease to the outside of the cap, o-ring and backup ring.

Install the cap into the cylinder. Be sure to push the cap below the snap ring groove.

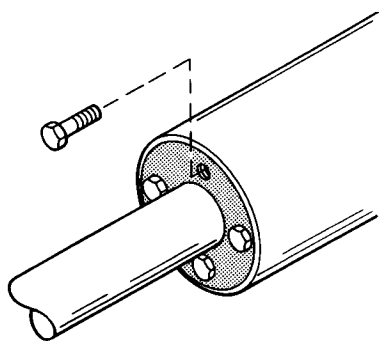

TS-21086

H. Install the retainer bolts and tighten to the correct torque (see Supplement 3283).

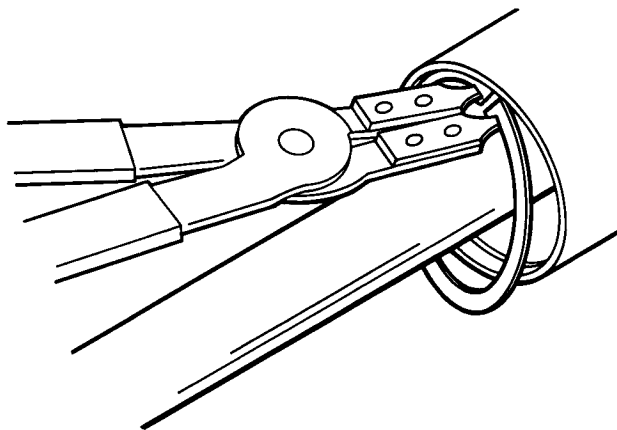

TS-21098

K. Install the snap ring.

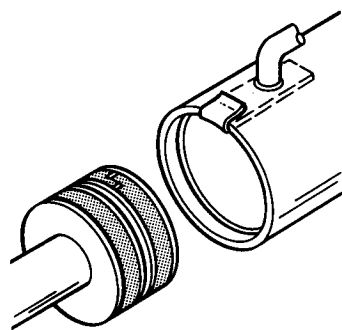

TS-21230

I. Apply grease to the outside of the piston. Make sure the wear ring splits are 180° apart. Install a ring compressor on the piston. Tighten the ring compressor to compress the rings to the correct size. Remove the compressor.

Insert a piece of .005 in (1,27 mm) shim stock, long and wide enough to cover the cylinder port, in the cylinder. Be sure the shim stock is long enough to be held so that it will not slide into the cylinder as the piston is pushed in.

Install the piston into the cylinder.

Remove the shim stock.

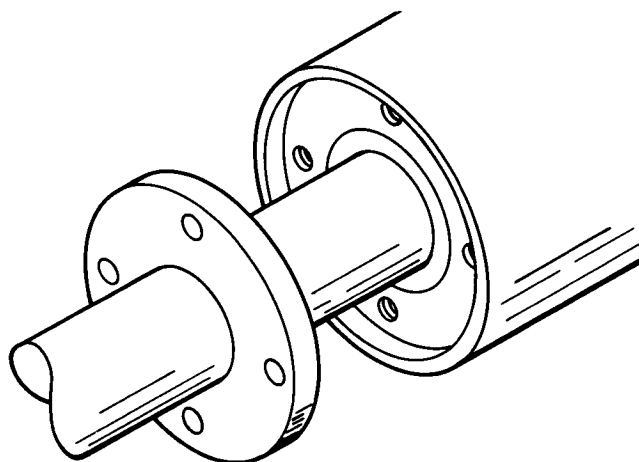

TS-21096

L. Apply grease to the outside of the flange, if used.

Install the flange into the cylinder with the bolt holes aligned with the holes in the cap.

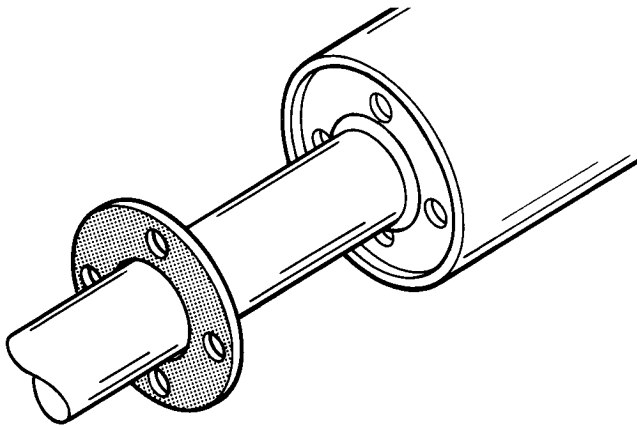

TS-21087

M. Install the retainer. Be sure to align the bolt holes with the holes in the flange.

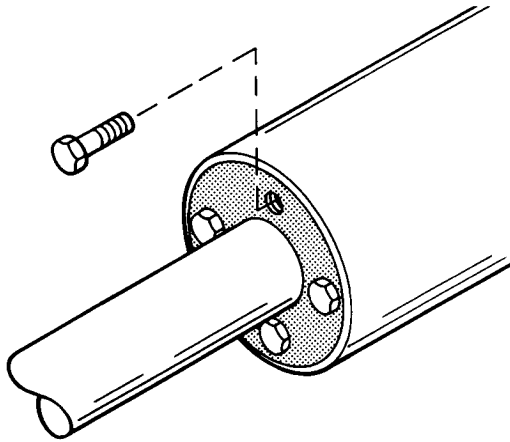

TS-21086

N. Install the retainer bolts. Tighten the bolts to the correct torque (see Supplement 3283).

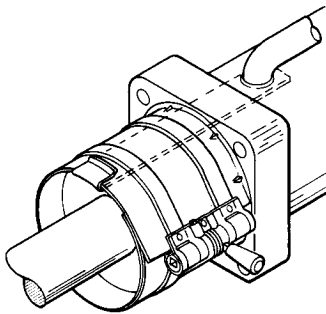

TS-21091

O. Apply grease to the outside of the piston. Make sure the wear ring splits are 180° apart. Install a ring compressor on the piston. Insert a piece of .005 in (1,27 mm) shim stock, long and wide enough to cover the cylinder port, between the compressor and the piston.

Be sure the shim stock is long enough to be held so that it will not slide into the cylinder as the piston is pushed in.

Tighten the ring compressor.

Push the piston out of the ring compressor and into the cylinder. Do not cause damage to the sealing ring or wear rings.

Remove the ring compressor and shim stock.

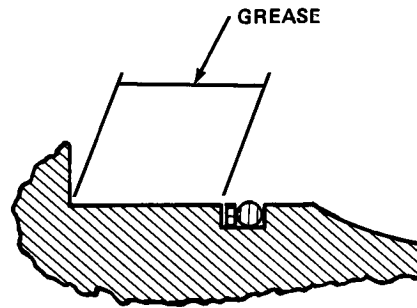

TS-30922

P. Apply grease to the backup ring and o-ring. Apply grease to the outside diameter of the cylinder cap to prevent rust.

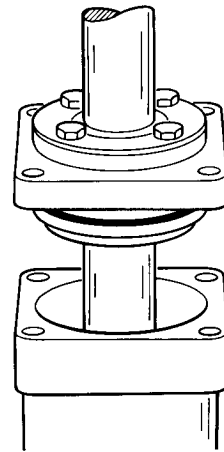

TS-21151

Q. If there is a port in the cap, align the alignment marks on the cap and cylinder. Install the cap into the cylinder with the bolt holes aligned.

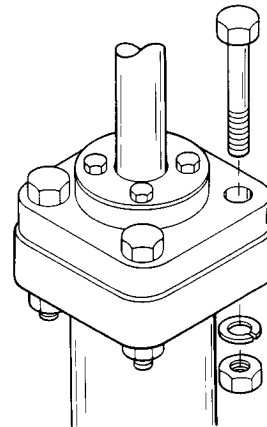

TS-21094

R. Install the cap bolts, washers and nuts. Tighten the bolts to the correct torque (see Supplement 3283).

CLARK

SEAL GUIDE

This tool is used to slowly expand the seals and protect them from damage as the cap is installed on the rod.

SAE 1020 CRS can be used to make the seal guide.

For cylinders with the piston held by a nut.

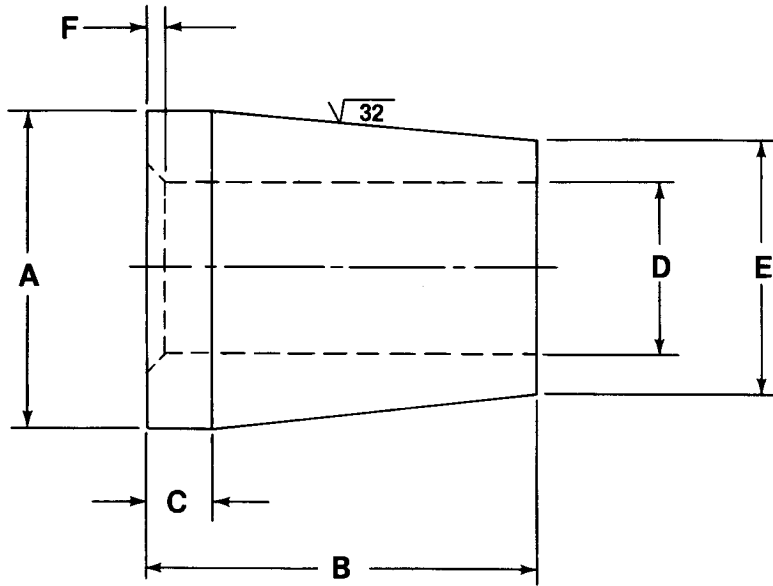

TS-20466

NOTE: Some of the rod diameters below are the same. The difference between the rods will be found in one of the seal guide dimensions. Be sure to find the seal guide that has the same dimensions as the rod being rebuilt, before starting to make the guide.

ROD DIA.		A - DIA.		B		C		D - DIA.		E - DIA.		F	
IN	MM	IN	MM	IN	MM	IN	MM	IN	MM	IN	MM	IN	MM
1.250	31,75	1.247-1.250	31,674-31,750	3.00	76,2	.500	12,7	.754-.756	19,152-19,203	1.00	25,4	.0625x45°	1,6x45°
1.250	31,75	1.247-1.250	3,674-31,750	3.00	76,2	.500	12,7	.992-.994	25,196-25,248	1.00	25,4	.0625x45°	1,6x45°
1.750	44,45	1.747-1.750	44,374-44,450	3.75	95,25	.500	12,7	1.377-1.379	34,976-35,027	1.50	38,1	.0625x45°	1,6x45°
2.000	50,80	1.997-2.000	50,72-50,80	4.25	107,95	.500	12,7	1.377-1.379	34,976-35,027	1.75	44,45	.0625x45°	1,6x45°
2.000	50,80	1.997-2.000	50,72-50,80	4.00	101,6	.500	12,7	1.627-1.629	41,326-41,377	1.75	44,45	.0625x45°	1,6x45°
2.250	51,435	2.247-2.250	51,427-51,435	4.50	114,3	.500	12,7	1.627-1.629	41,326-41,377	2.00	50,8	.0625x45°	1,6x45°
2.250	51,435	2.247-2.250	51,427-51,435	4.00	101,6	.500	12,7	1.802-1.804	45,771-45,822	2.00	50,8	.0625x45°	1,6x45°
2.250	51,435	2.247-2.250	51,427-51,435	4.00	101,6	.500	12,7	1.877-1.879	47,676-47,727	2.00	50,8	.0625x45°	1,6x45°
2.750	69,850	2.747-2.750	69,770-69,850	4.50	114,3	.500	12,7	2.127-2,129	54,026-54,077	2.500	63,5	.0625x45°	1,6x45°
2.750	69,850	2.747-2.750	69,770-69,850	5.00	127,0	.500	12,7	2.002-2.004	50,85-50,92	2.500	63,5	.0625x45°	1,6x45°
3.500	88,90	3.497-3.500	88,62-88,90	6.50	165,1	1.00	25,4	2.752-2.754	69,901-69,952	3.250	82,55	.0625x45°	1,6x45°
4.500	114,30	4.497-4.500	114,22-114,30	7.00	177,8	1.00	25,4	3.252-3.254	82,601-82,652	4.250	107,95	.0625x45°	1,6x45°

CLARK

For cylinders with pistons that have threads inside.

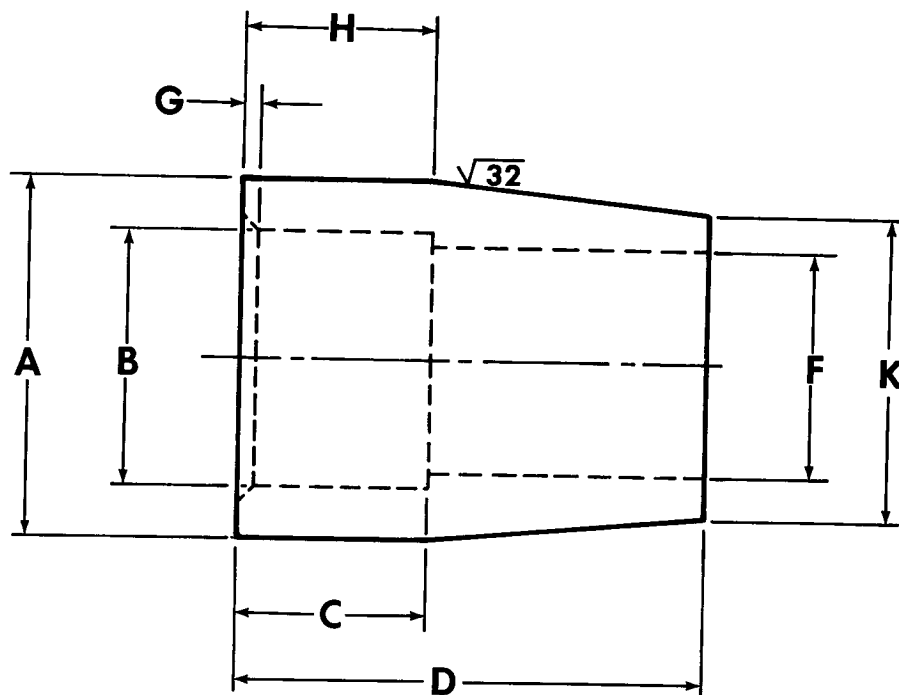

TS-16180

ROD DIA.		A - DIA.		B - DIA.		C		D		F - DIA.		G		H		K - DIA.	
IN	MM	IN	MM	IN	MM	IN	MM	IN	MM	IN	MM	IN	MM	IN	MM	IN	MM
1.250	31,75	1.247-1.250	31,674-31,750	1.002-1.004	25,451-25,502	1.506	38,253	3.00	76,20	.790	20,066	.0625x45°	1,6x45°	1.500	38,100	1.00	25,40
1.750	44,45	1.747-1.750	44,374-44,450	1.502-1.504	38,151-38,202	1.830	46,482	3.50	88,90	1.383	35,129	.0625x45°	1,6x45°	1.830	46,482	1.50	38,10
2.00	50,80	1.997-2.000	50,72-50,80	1.752-1.754	44,501-44,552	1.820	46,228	3.50	88,90	1.617	41,073	.0625x45°	1,6x45°	1.820	46,228	1.75	44,45
2.25	51,435	2.247-2.250	51,427-51,435	2.002-2.004	50,851-50,902	1.810	45,974	3.50	88,90	1.903	48,337	.0625x45°	1,6x45°	1.810	45,974	2.00	50,80
2.75	69,85	2.747-2.750	69,770-69,850	2.502-2.504	63,551-63,602	1.610	40,894	3.50	88,90	2.303	58,497	.0625x45°	1,6x45°	1.610	40,894	2.50	63,50
3.00	76,20	2.997-3.000	76,124-76,200	2.752-2.754	69,901-69,952	1.710	43,434	3.50	88,90	2.263	57,481	.0625x45°	1,6x45°	1.710	43,434	2.75	69,85
3.50	88,90	3.497-3.500	88,62-88,90	3.252-3.254	82,601-82,652	2.710	68,834	5.00	127,0	2.763	70,181	.0625x45°	1,6x45°	2.710	68,834	3.25	82,55
4.00	101,6	3.997-4.000	91,524-101,600	3.752-3.754	95,301-95,352	2.910	73,914	5.00	127,0	3.203	81,357	.0625x45°	1,6x45°	2.910	73,914	3.75	95,25
4.50	114,30	4.497-4.500	114,22-114,300	4.252-4.254	108,001-108,052	4.770	121,26	6.75	171,45	3.503	88,977	.0625x45°	1,6x45°	4.770	121,26	4.25	107,95
5.00	127,0	4.997-5.000	126,924-127,000	4.752-4.754	120,701-120,752	3.710	94,234	6.00	152,4	4.003	101,677	.0625x45°	1,6x45°	3.710	94,234	4.75	119,65

CLARK

ADJUSTABLE SPANNER WRENCH

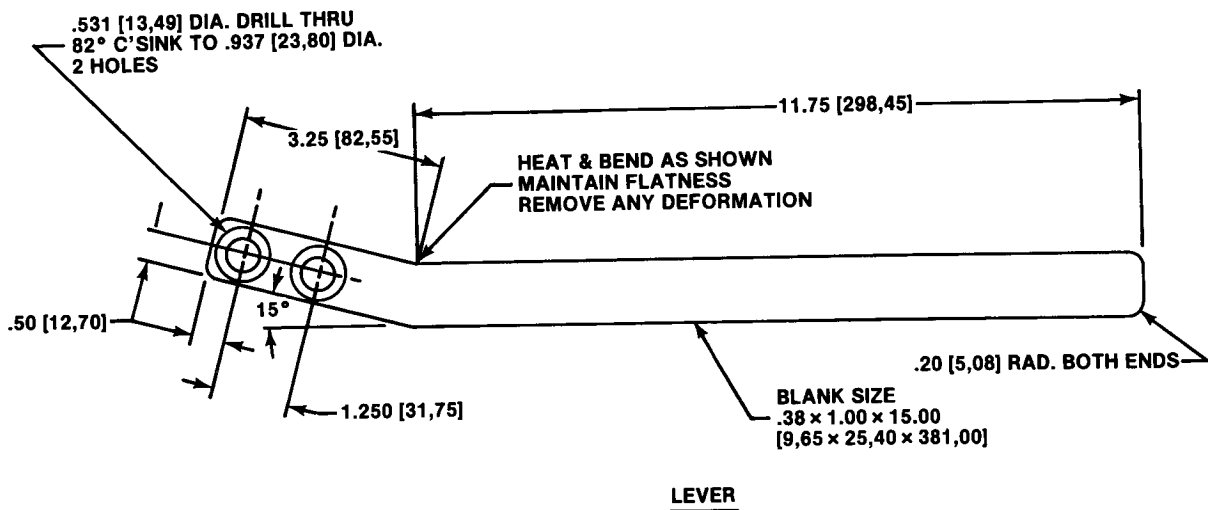
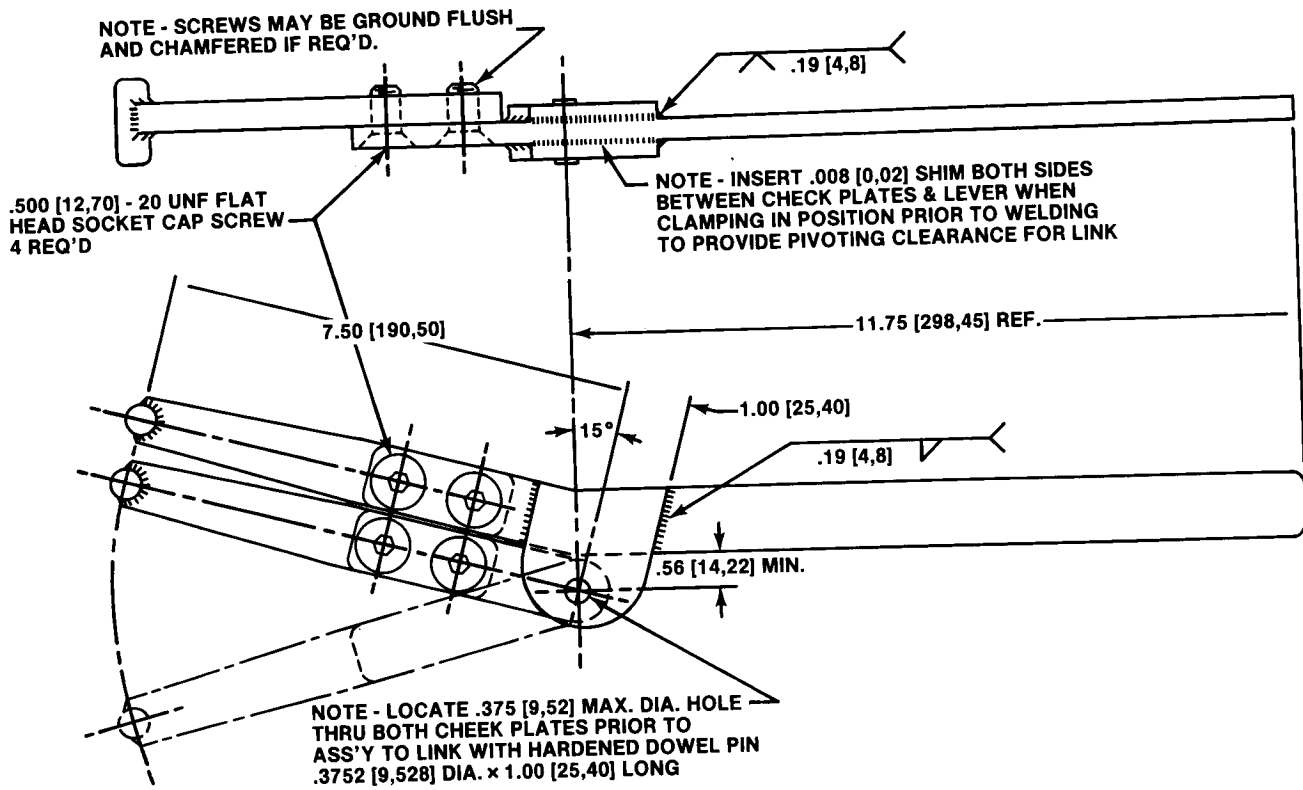

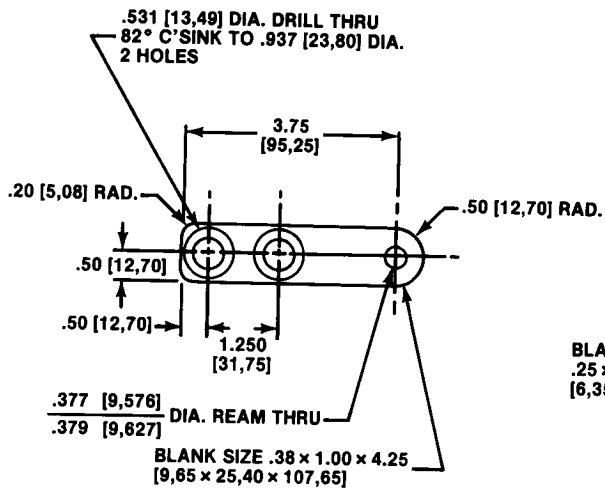

LINK

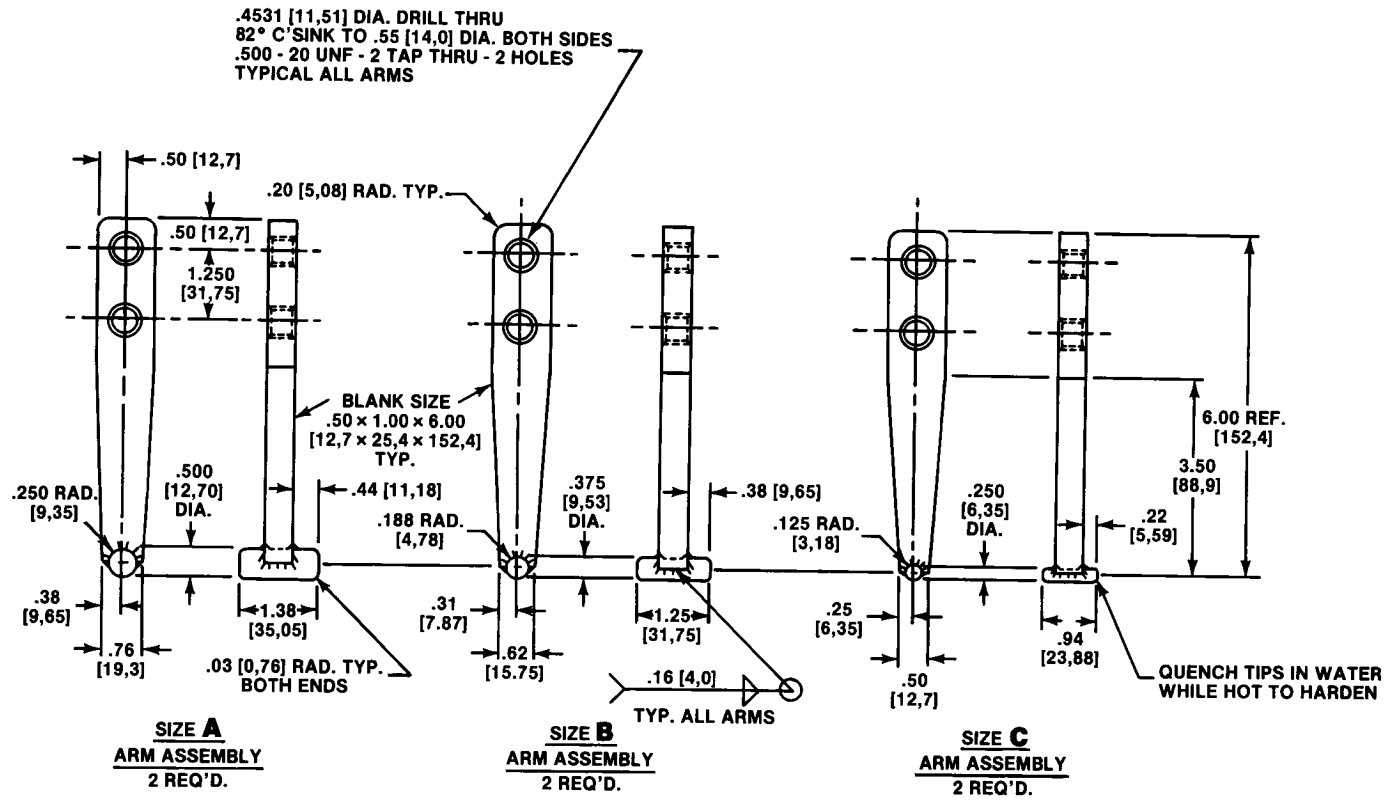
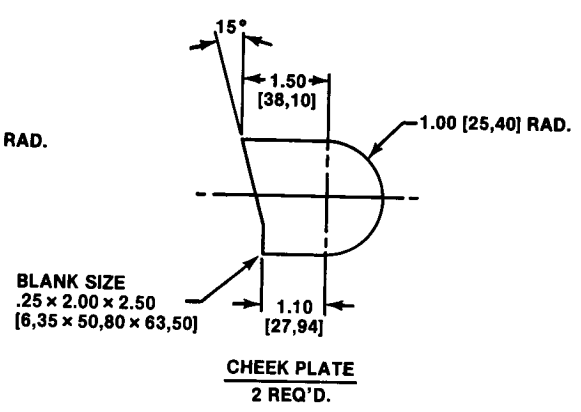

NOTE - ALL CONSTRUCTION MATERIALS
S.A.E. 1045 H.R. COMMERCIAL QUAL. STEEL
BARS - FLATS - ROUNDS
ALL WELDS WILL USE A.W.S. E 7018 OR EQUIV.

FINISH - DEGREASE - PRIME & ONE COAT FLAT BLACK ENAMEL

PISTON DOWELPIN PULLER

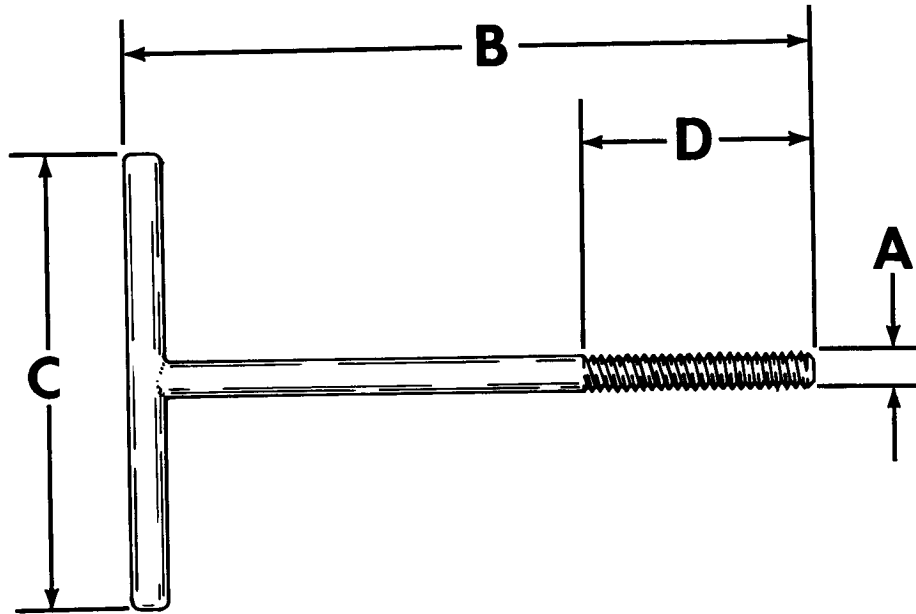

TS-16183

A	B	C	D
NO. 12-.216 IN (3,048 mm) - 24 UNC-2B THD	4.0 IN (101,6 mm)	2.0 IN (50,8 mm)	2.0 IN (50,8 mm)
NO. 5-.125 IN (3,175 mm) - 40 UNC-2B THD	3.0 IN (76,2 mm)	2.0 IN (50,8 mm)	.750 IN (19,05 mm)
NO. 8-.164 IN (4,165 mm) - 32 UNC-2B THD	3.0 IN (76,2 mm)	2.0 IN (50,8 mm)	1.0 IN (25,4 mm)

CLARK

≡ SHOP MANUAL SUPPLEMENT ≡

No. 3283

★

CYLINDER SPECIFICATIONS

★

This supplement gives the specifications needed to assemble cylinders correctly. It also gives original dimensions of cylinder components to be used as a guide when checking the components.

★

Use this supplement with the Cylinder Shop Manual publication No. 3275.

CLARK EQUIPMENT COMPANY

FOREWORD

The cylinders in this Supplement have been shown by model and application. If the cylinder is not on a machine, the type of cylinder can be found by the Part Number stamped into the tube or the Part Number stamped on the plate fastened to the side of the tube (see Illustration below).

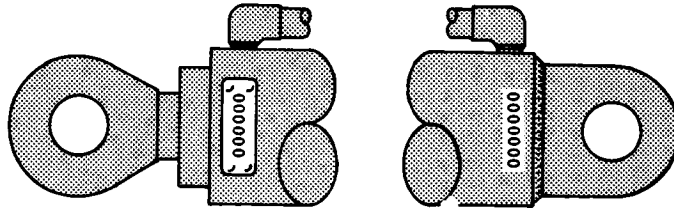

TS-16622



CLARK

ASSEMBLY SPECIFICATIONS

Cylinder Number	Piston Nut Torque			Piston Lock Bolt Torque (Threaded Pistons Only)			Cylinder Cap Bolt Torque			Retainer Ring Bolt Torque			Piston to Center of Rod Eye Dimension	
	lb·ft	N·m	kgf·m	lb·ft	N·m	kgf·m	lb·ft	N·m	kgf·m	lb·ft	N·m	kgf·m	in	mm

35C BOOM

2518199	---	---	---	20	27	2,8	175	240	24,2	40	54	5,5	34.84	885
2518201	---	---	---	20	27	2,8	175	240	24,2	40	54	5,5	34.84	885
2521767	---	---	---	20	27	2,8	175	240	24,2	40	54	5,5	35.63	905
2521768	---	---	---	20	27	2,8	175	240	24,2	40	54	5,5	35.63	905
2521773	---	---	---	20	27	2,8	175	240	24,2	40	54	5,5	34.84	885
2521774	---	---	---	20	27	2,8	175	240	24,2	40	54	5,5	34.84	885
2523265	---	---	---	18-20	24-27	2,5-2,8	175-190	240-260	24,2-26,3	35-40	48-54	4,8-5,5	34.84	885
2523266	---	---	---	18-20	24-27	2,5-2,8	175-190	240-260	24,2-26,3	35-40	48-54	4,8-5,5	34.84	885

35C BUCKET

2518191	---	---	---	7	9,5	,97	50	68	6,9	4	5,4	,55	46.69	1186
2518193	---	---	---	7	9,5	,97	50	68	6,9	4	5,4	,55	46.69	1186
2518196	---	---	---	7	9,5	,97	50	68	6,9	4	5,4	,55	52.99	1346
2518197	---	---	---	7	9,5	,97	50	68	6,9	4	5,4	,55	52.99	1346
2521041	---	---	---	20	27	2,8	90-100	122-135	16,9-18,9	10	14	1,4	46.69	1186
2521042	---	---	---	20	27	2,8	90-100	122-135	16,9-18,9	10	14	1,4	52.99	1346
2521043	---	---	---	20	27	2,8	90-100	122-135	16,9-18,9	10	14	1,4	46.69	1186
2521044	---	---	---	20	27	2,8	90-100	122-135	16,9-18,9	10	14	1,4	52.99	1346
2523229	---	---	---	18-20	24-27	2,5-2,8	90-100	122-135	16,9-18,9	9-10	13-14	1,2-1,4	43.31	1100
2523230	---	---	---	18-20	24-27	2,5-2,8	90-100	122-135	16,9-18,9	9-10	13-14	1,2-1,4	43.31	1100
2526749	---	---	---	18-20	24-27	2,5-2,8	90-100	122-135	16,9-18,9	9-10	13-14	1,2-1,4	43.31	1100
2526750	---	---	---	18-20	24-27	2,5-2,8	90-100	122-135	16,9-18,9	9-10	13-14	1,2-1,4	43.31	1100

35C STEER

2511942	175	237	24,2	---	---	---	---	---	---	2	2,7	,28	---	---
2518513	175	237	24,2	---	---	---	---	---	---	2	2,7	,28	---	---
2526859	---	---	---	7-8	9-10	,96-1,1	---	---	---	7-8	9-10	,96-1,1	19.488	495

45B BOOM

3980095	750	1017	103,70	---	---	---	90	122	16,9	33	45	4,6	---	---
---------	-----	------	--------	-----	-----	-----	----	-----	------	----	----	-----	-----	-----

45B BUCKET

3980108	500	680	69,10	---	---	---	90	122	16,9	33	45	4,6	---	---
3980125	500	680	69,10	---	---	---	90	122	16,9	33	45	4,6	---	---

45B STEER

3980906	250	340	34,6	---	---	---	---	---	---	14	19	1,9	---	---
---------	-----	-----	------	-----	-----	-----	-----	-----	-----	----	----	-----	-----	-----

45FB BOOM

3980095	750	1017	103,70	---	---	---	90	122	16,9	33	45	4,6	---	---
---------	-----	------	--------	-----	-----	-----	----	-----	------	----	----	-----	-----	-----

45FB TILT

3980108	500	680	69,10	---	---	---	90	122	16,9	33	45	4,6	---	---
3980125	500	680	69,10	---	---	---	90	122	16,9	33	45	4,6	---	---

45FB STEER

3980906	250	340	34,6	---	---	---	---	---	---	14	19	1,9	---	---
---------	-----	-----	------	-----	-----	-----	-----	-----	-----	----	----	-----	-----	-----

CLARK

CYLINDER SPECIFICATIONS (ORIGINAL DIMENSIONS)

Cylinder Number	Rod Diameter		Tube Bore		Cap or Sleeve Bore		Stroke	
	in	mm	in	mm	in	mm	in	mm

35C BOOM

2518199	2.003-2.000	50,876-50,800	4.030-4.025	102,36-102,24	2.008-2.006	51,00-50,95	26.78	680
2518201	2.003-2.000	50,876-50,800	4.030-4.025	102,36-102,24	2.008-2.006	51,00-50,95	26.78	680
2521767	2.003-2.000	50,876-50,800	4.530-4.525	115,06-114,94	2.008-2.006	51,00-50,95	21.17	690
2521768	2.003-2.000	50,876-50,800	4.530-4.525	115,06-114,94	2.008-2.006	51,00-50,95	21.17	690
2521773	2.003-2.000	50,876-50,800	4.030-4.025	102,36-102,24	2.008-2.006	51,00-50,95	26.78	680
2521774	2.003-2.000	50,876-50,800	4.030-4.025	102,36-102,24	2.008-2.006	51,00-50,95	26.78	680
2523265	2.003-2.000	50,876-50,800	4.030-4.025	102,36-102,24	2.008-2.006	51,00-50,95	26.78	680
2523266	2.003-2.000	50,876-50,800	4.030-4.025	102,36-102,24	2.008-2.006	51,00-50,95	26.78	680

35C BUCKET

2518191	1.753-1.750	44,526-44,450	3.530-3.525	89,66-89,54	1.758-1.756	44,65-44,60	27.17	690
2518193	1.753-1.750	44,526-44,450	3.530-3.525	89,66-89,54	1.758-1.756	44,65-44,60	27.17	690
2518196	1.753-1.750	44,526-44,450	3.530-3.525	89,66-89,54	1.758-1.756	44,65-44,60	27.17	690
2518197	1.753-1.750	44,526-44,450	3.530-3.525	89,66-89,54	1.758-1.756	44,65-44,60	27.17	690
2521041	1.753-1.750	44,526-44,450	3.530-3.525	89,66-89,54	1.758-1.756	44,65-44,60	25.79	655
2521042	1.753-1.750	44,526-44,450	3.530-3.525	89,66-89,54	1.758-1.756	44,65-44,60	25.79	655
2521043	1.753-1.750	44,526-44,450	3.530-3.525	89,66-89,54	1.758-1.756	44,65-44,60	25.79	655
2521044	1.752-1.750	44,500-44,450	3.530-3.525	89,66-89,54	1.758-1.756	44,65-44,60	25.79	655
2523229	1.753-1.750	44,526-44,450	3.530-3.525	89,66-89,54	1.758-1.756	44,65-44,60	25.79	655
2523230	1.753-1.750	44,526-44,450	3.530-3.525	89,66-89,54	1.758-1.756	44,65-44,60	25.79	655
2526749	1.752-1.750	44,500-44,450	3.530-3.525	89,66-89,54	1.758-1.756	44,65-44,60	25.79	655
2526750	1.752-1.750	44,500-44,450	3.530-3.525	89,66-89,54	1.758-1.756	44,65-44,60	25.79	655

35C STEER

2511942	1.250-1.247	31,750-31,674	2.530-2.525	64,26-64,14	1.254-1.252	31,85-31,80	14.02	356
2518513	1.253-1.250	31,826-31,750	2.530-2.525	64,26-64,14	1.258-1.256	31,95-31,90	14.02	356
2526859	1.250-1.247	31,750-31,674	2.530-2.525	64,26-64,14	1.255-1.253	31,87-31,83	14.02	356

45B BOOM

3980095	2.003-2.000	50,876-50,800	4.530-4.525	115,06-114,94	2.008-2.006	51,00-50,95	30.90	785
---------	-------------	---------------	-------------	---------------	-------------	-------------	-------	-----

45B BUCKET

3980108	1.753-1.750	44,526-44,450	3.530-3.525	89,66-89,54	1.758-1.756	44,65-44,60	16.22	412,0
3980125	1.753-1.750	44,526-44,450	3.530-3.525	89,66-89,54	1.758-1.756	44,65-44,60	16.22	412,0

45B STEER

3980906	1.250-1.247	31,750-31,674	2.530-2.525	64,26-64,14	1.254-1.252	31,85-31,80	17.72	450,1
---------	-------------	---------------	-------------	-------------	-------------	-------------	-------	-------

45FB BOOM

3980095	2.003-2.000	50,876-50,800	4.530-4.525	115,06-114,94	2.008-2.006	51,00-50,95	30.90	785
---------	-------------	---------------	-------------	---------------	-------------	-------------	-------	-----

45FB TILT

3980108	1.753-1.750	44,526-44,450	3.530-3.525	89,66-89,54	1.758-1.756	44,65-44,60	16.22	412,0
3980125	1.753-1.750	44,526-44,450	3.530-3.525	89,66-89,54	1.758-1.756	44,65-44,60	16.22	412,0

45FB STEER

3980906	1.250-1.247	31,750-31,674	2.530-2.525	64,26-64,14	1.254-1.252	31,85-31,80	17.72	450,1
---------	-------------	---------------	-------------	-------------	-------------	-------------	-------	-------

CLARK

ASSEMBLY SPECIFICATIONS

Cylinder Number	Piston Nut Torque			Piston Lock Bolt Torque (Threaded Pistons Only)			Cylinder Cap Bolt Torque			Retainer Ring Bolt Torque			Piston to Center of Rod Eye Dimension	
	lb·ft	N·m	kgf·m	lb·ft	N·m	kgf·m	lb·ft	N·m	kgf·m	lb·ft	N·m	kgf·m	in	mm

45C BOOM

2518204	---	---	---	20	27	2,8	175	240	24,2	40	54	5,5	35.63	905
2518206	---	---	---	20	27	2,8	175	240	24,2	40	54	5,5	35.63	905
2521767	---	---	---	20	27	2,8	175	240	24,2	40	54	5,5	35.63	905
2521768	---	---	---	20	27	2,8	175	240	24,2	40	54	5,5	35.63	905
2521773	---	---	---	20	27	2,8	175	240	24,2	40	54	5,5	35.63	905
2521774	---	---	---	20	27	2,8	175	240	24,2	40	54	5,5	34.84	885
2522734	---	---	---	18-20	24-27	2,5-2,8	175-190	240-260	24,2-26,3	40	54	5,5	34.84	885
2522735	---	---	---	18-20	24-27	2,5-2,8	175-190	240-260	24,2-26,3	35-40	48-54	4,8-5,5	35.63	905
2523265	---	---	---	18-20	24-27	2,5-2,8	175-190	240-260	24,2-26,3	35-40	48-54	4,8-5,5	35.63	905
2523266	---	---	---	18-20	24-27	2,5-2,8	175-190	240-260	24,2-26,3	35-40	48-54	4,8-5,5	34.84	885
2538691	---	---	---	18-20	24-27	2,5-2,8	175-190	240-260	24,2-26,3	35-40	48-54	4,8-5,5	34.84	885
2538692	---	---	---	18-20	24-27	2,5-2,8	175-190	240-260	24,2-26,5	35-40	48-54	4,8-5,5	35.63	905

45C BUCKET

2518191	---	---	---	7	9,5	,97	50	68	6,9	4	5,4	,55	46.69	1186
2518193	---	---	---	7	9,5	,97	50	68	6,9	4	5,4	,55	46.69	1186
2518196	---	---	---	7	9,5	,97	50	68	6,9	4	5,4	,55	52.99	1346
2518197	---	---	---	7	9,5	,97	50	68	6,9	4	5,4	,55	52.99	1346
2521041	---	---	---	20	27	2,8	90-100	122-135	16,9-18,9	10	14	1,4	46.69	1186
2521042	---	---	---	20	27	2,8	90-100	122-135	16,9-18,9	10	14	1,4	52.99	1346
2521043	---	---	---	20	27	2,8	90-100	122-135	16,9-18,9	10	14	1,4	46.69	1186
2521044	---	---	---	20	27	2,8	90-100	122-135	16,9-18,9	10	14	1,4	52.99	1346
2522923	---	---	---	18-20	24-27	2,5-2,8	90-100	122-135	16,9-18,9	9-10	13-14	1,2-1,4	49.05	1246
2522924	---	---	---	18-20	24-27	2,5-2,8	90-100	122-135	16,9-18,9	9-10	13-14	1,2-1,4	49.05	1246
2526536	---	---	---	18-20	24-27	2,5-2,8	90-100	122-135	16,9-18,9	9-10	13-14	1,2-1,4	49.05	1246
2526537	---	---	---	18-20	24-27	2,5-2,8	90-100	122-135	16,9-18,9	9-10	13-14	1,2-1,4	49.05	1246
2526749	---	---	---	18-20	24-27	2,5-2,8	90-100	122-135	16,9-18,9	9-10	13-14	1,2-1,4	43.31	1100
2526750	---	---	---	18-20	24-27	2,5-2,8	90-100	122-135	16,9-18,9	9-10	13-14	1,2-1,4	43.31	1100

45C STEER

2511942	175	237	24,2	---	---	---	---	---	---	2	2,7	,28	---	---
2518513	175	237	24,2	---	---	---	---	---	---	2	2,7	,28	---	---
2526859	---	---	---	7-8	9-10	,96-1,1	---	---	---	7-8	9-10	,96-1,1	19.488	495

55B BOOM

964660	750	1017	103,7	---	---	---	90-100	122-135	16,9-18,9	17	23	2,4	---	---
964661	750	1017	103,7	---	---	---	90-100	122-135	16,9-18,9	17	23	2,4	---	---
1546056	750	1017	103,7	---	---	---	90	122	16,9	90-100	122-135	16,9-18,9	---	---
1546057	750	1017	103,7	---	---	---	90	122	16,9	90-100	122-135	16,9-18,9	---	---
2514111	750	1017	103,7	---	---	---	90-100	122-135	16,9-18,9	17	23	2,4	---	---
2514122	750	1017	103,7	---	---	---	90-100	122-135	16,9-18,9	17	23	2,4	---	---
2528603	750	1017	103,7	---	---	---	90-100	122-135	16,9-18,9	35-40	48-54	4,8-5,5	---	---
2528604	750	1017	103,7	---	---	---	90-100	122-135	16,9-18,9	35-40	48-54	4,8-5,5	---	---

55B BUCKET

964669	400	542	55,3	---	---	---	175-190	240-260	24,2-26,3	18-20	24-27	2,5-2,8	---	---
1549758	400	542	55,3	---	---	---	210	285	29,0	90-100	122-135	16,9-18,9	---	---
2514258	400	542	55,3	---	---	---	175-190	240-260	24,2-26,3	7	9,5	,97	---	---
2532655	400	542	55,3	---	---	---	175-190	240-260	24,2-26,3	18-20	24-27	2,5-2,8	---	---

CLARK

CYLINDER SPECIFICATIONS (ORIGINAL DIMENSIONS)

Cylinder Number	Rod Diameter		Tube Bore		Cap or Sleeve Bore		Stroke	
	in	mm	in	mm	in	mm	in	mm

45C BOOM

2518204	2.003-2.000	50,876-50,800	4.530-4.525	115,06-114,94	2.008-2.006	51,00-50,95	27.17	690
2518206	2.003-2.000	50,876-50,800	4.530-4.525	115,06-114,94	2.008-2.006	51,00-50,95	27.17	690
2521767	2.003-2.000	50,876-50,800	4.530-4.525	115,06-114,94	2.008-2.006	51,00-50,95	27.17	690
2521768	2.003-2.000	50,876-50,800	4.530-4.525	115,06-114,94	2.008-2.006	51,00-50,95	27.17	690
2521773	2.003-2.000	50,876-50,800	4.030-4.025	102,36-102,24	2.008-2.006	51,00-50,95	26.78	680
2521774	2.003-2.000	50,876-50,800	4.030-4.025	102,36-102,24	2.008-2.006	51,00-50,95	26.78	680
2522734	2.003-2.000	50,876-50,800	4.530-4.525	115,06-114,94	2.008-2.006	51,00-50,95	27.17	690
2522735	2.003-2.000	50,876-50,800	4.530-4.425	115,06-114,94	2.008-2.006	51,00-50,95	27.17	690
2523265	2.003-2.000	50,876-50,800	4.030-4.025	102,36-102,24	2.008-2.006	51,00-50,95	26.78	680
2523266	2.003-2.000	50,876-50,800	4.030-4.025	102,36-102,24	2.008-2.006	51,00-50,95	26.78	680
2538691	2.003-2.000	50,876-50,800	4.530-4.525	115,06-114,94	2.008-2.006	51,00-50,95	27.17	690
2538692	2.003-2.000	50,876-50,800	4.530-4.525	115,06-114,94	2.008-2.006	51,00-50,95	27.17	690

45C BUCKET

2518191	1.753-1.750	44,526-44,450	3.530-3.525	89,66-89,54	1.758-1.756	44,65-44,60	27.17	690
2518193	1.753-1.750	44,526-44,450	3.530-3.525	89,66-89,54	1.758-1.756	44,65-44,60	27.17	690
2518196	1.753-1.750	44,526-44,450	3.530-3.525	89,66-89,54	1.758-1.756	44,65-44,60	27.17	690
2518197	1.753-1.750	44,526-44,450	3.530-3.525	89,66-89,54	1.758-1.756	44,65-44,60	27.17	690
2521041	1.753-1.750	44,526-44,450	3.530-3.525	89,66-89,54	1.758-1.756	44,65-44,60	25.79	655
2521042	1.753-1.750	44,526-44,450	3.530-3.525	89,66-89,54	1.758-1.756	44,65-44,60	25.79	655
2521043	1.753-1.750	44,526-44,450	3.530-3.525	89,66-89,54	1.758-1.756	44,65-44,60	25.79	655
2521044	1.753-1.750	44,526-44,450	3.530-3.525	89,66-89,54	1.758-1.756	44,65-44,60	25.79	655
2522923	1.753-1.750	44,526-44,450	3.530-3.525	89,66-89,54	1.758-1.756	44,65-44,60	25.79	655
2522924	1.753-1.750	44,526-44,450	3.530-3.525	89,66-89,54	1.758-1.756	44,65-44,60	25.79	655
2526536	1.752-1.750	44,500-44,450	3.530-3.525	89,66-89,54	1.758-1.756	44,65-44,60	25.79	655
2526537	1.752-1.750	44,500-44,450	3.530-3.525	89,66-89,54	1.758-1.756	44,65-44,60	25.79	655
2526749	1.752-1.750	44,500-44,450	3.530-3.525	89,66-89,54	1.758-1.756	44,65-44,60	25.79	655
2526750	1.752-1.750	44,500-44,450	3.530-3.525	89,66-89,54	1.758-1.756	44,65-44,60	25.79	655

45C STEER

2511942	1.250-1.247	31,750-31,674	2.530-2.525	64,26-64,14	1.254-1.252	31,85-31,80	14.02	356
2518513	1.253-1.250	31,826-31,750	2.530-2.525	64,26-64,14	1.258-1.256	39,95-31,90	14.02	356
2526859	1.250-1.247	31,750-31,674	2.530-2.525	64,26-64,14	1.255-1.253	31,87-31,83	14.02	356

55B BOOM

964660	2.253-2.250	57,226-57,150	5.030-5.025	127,76-127,64	—	—	34.20	868,7
964661	2.253-2.250	57,226-57,150	5.030-5.025	127,76-127,64	—	—	34.20	868,7
1546056	2.253-2.250	57,226-27,150	5.030-5.025	127,76-127,64	—	—	34.20	868,7
1546057	2.253-2.250	57,226-57,150	5.030-5.025	127,76-127,64	2.258-2.256	57,353-57,303	34.20	868,7
2514111	2.253-2.250	57,226-57,150	5.030-5.025	127,76-127,64	2.258-2.256	57,353-57,303	34.20	868,7
2514122	2.253-2.250	57,226-57,150	5.030-5.025	127,76-127,64	2.258-2.256	57,353-57,303	34.20	868,7
2528603	2.253-2.250	57,226-57,150	5.030-5.025	127,76-127,64	2.258-2.256	57,353-57,303	34.20	868,7
2528604	2.253-2.250	57,226-57,150	5.030-5.025	127,76-127,64	2.258-2.256	57,353-57,303	34.20	868,7

55B BUCKET

964669	2.003-2.000	50,876-50,800	4.030-4.025	102,36-102,24	2.008-2.006	51,00-50,95	15.75	400,0
1549758	2.003-2.000	50,876-50,800	4.030-4.025	102,36-102,24	2.008-2.006	51,00-50,95	15.75	399,8
2514258	2.003-2.000	50,876-50,800	4.030-4.025	102,36-102,24	2.008-2.006	51,00-50,95	15.75	400,0
2532655	2.003-2.000	50,876-50,800	4.030-4.025	102,36-102,24	2.008-2.006	51,00-50,95	15.75	400,0

CLARK

ASSEMBLY SPECIFICATIONS

Cylinder Number	Piston Nut Torque			Piston Lock Bolt Torque (Threaded Pistons Only)			Cylinder Cap Bolt Torque			Retainer Ring Bolt Torque			Piston to Center of Rod Eye Dimension	
	lb·ft	N·m	kgf·m	lb·ft	N·m	kgf·m	lb·ft	N·m	kgf·m	lb·ft	N·m	kgf·m	in	mm

55B STEER

1508904	400	542	55,3	---	---	---	---	---	---	7	9,5	,97	---	---
2518802	---	---	---	20	27	2,8	---	---	---	4	5,4	,55	20.98	532,9
2532705	---	---	---	18-20	24-27	2,5-2,8	---	---	---	9-10	13-14	1,2-1,4	20.90	530

55C BOOM

2523872	---	---	---	18-20	24-27	2,5-2,8	175-190	240-260	24,2-26,3	35-40	48-54	4,8-5,5	35.63	905
2523873	---	---	---	18-20	24-27	2,5-2,8	175-190	240-260	24,2-26,3	35-40	48-54	4,8-5,5	35.63	905

55C BUCKET

2523950	---	---	---	18-20	24-27	2,5-2,8	175-190	240-260	24,2-26,3	35-40	48-54	4,8-5,5	52.72	1339
2523951	---	---	---	18-20	24-27	2,5-2,8	175-190	240-260	24,2-26,3	35-40	48-54	4,8-5,5	52.72	1339
2526667	---	---	---	18-20	24-27	2,5-2,8	175-190	240-260	24,2-26,3	35-40	48-54	4,8-5,5	52.72	1339
2526668	---	---	---	18-20	24-27	2,5-2,8	175-190	240-260	24,2-26,3	35-40	48-54	4,8-5,5	52.72	1339

55C STEER

2526859	---	---	---	7-8	9-10	,96-1,1	---	---	---	7-8	9-10	,96-1,1	19.488	495
---------	-----	-----	-----	-----	------	---------	-----	-----	-----	-----	------	---------	--------	-----

75B BOOM

962702	750	1017	103,7	---	---	---	90-100	122-135	16,9-18,9	17	23	2,4	---	---
962703	750	1017	103,7	---	---	---	90-100	122-135	16,9-18,9	17	23	2,4	---	---
1518977	750	1017	103,7	---	---	---	90	122	16,9	17	23	2,4	---	---
1518978	750	1017	103,7	---	---	---	90	122	16,9	17	23	2,4	---	---
1546056	750	1017	103,7	---	---	---	90	122	16,9	90-100	122-135	16,9-18,9	---	---
1546057	750	1017	103,7	---	---	---	90	122	16,9	90-100	122-135	16,9-18,9	---	---
2514111	750	1017	103,7	---	---	---	90-100	122-135	16,9-18,9	17	23	2,4	---	---
2514122	750	1017	103,7	---	---	---	90-100	122-135	16,9-18,9	17	23	2,4	---	---
2518075	750	1017	103,7	---	---	---	90-100	122-135	16,9-18,9	17	23	2,4	---	---
2518076	750	1017	103,7	---	---	---	90-100	122-135	16,9-18,9	17	23	2,4	---	---
2527513	---	---	---	18-20	24-27	2,5-2,8	90-100	122-135	16,9-18,9	35-40	48-54	4,8-5,5	40.80	1036,4
2527549	---	---	---	18-20	24-27	2,5-2,8	90-100	122-135	16,9-18,9	35-40	48-54	4,8-5,5	40.80	1036,4
2528565	---	---	---	18-20	24-27	2,5-2,8	90-100	122-135	16,9-18,9	35-40	48-54	4,8-5,5	40.80	1036,4
2528566	---	---	---	18-20	24-27	2,5-2,8	90-100	122-135	16,9-18,9	35-40	48-54	4,8-5,5	40.80	1036,4

75B BUCKET

964581	750	1017	103,7	---	---	---	175-190	240-260	24,2-26,3	35-40	48-54	4,8-5,5	---	---
1511554	400	542	55,3	---	---	---	210	285	29,0	17	23	2,4	---	---
2518071	400	542	55,30	---	---	---	175-190	240-260	24,2-26,3	17	23	2,4	---	---
2520412	750	1017	103,7	---	---	---	175-190	240-260	24,2-26,3	35-40	48-54	4,8-5,5	---	---
2532204	750	1017	103,7	---	---	---	175-190	240-260	24,2-26,3	35-40	48-54	4,8-5,5	---	---

75B STEER

1508904	400	542	55,3	---	---	---	---	---	---	7	9,5	,97	---	---
2518802	---	---	---	20	27	2,8	---	---	---	4	5,4	,55	20.98	532,9
2532705	---	---	---	18-20	24-27	2,5-2,8	---	---	---	9-10	13-14	1,2-1,4	20.90	530

LF 75B BOOM

1546056	750	1017	103,7	---	---	---	90	122	16,9	90-100	122-135	16,9-18,9	---	---
1546057	750	1017	103,7	---	---	---	90	122	16,9	90-100	122-135	16,9-18,9	---	---
2514111	750	1017	103,7	---	---	---	90-100	122-135	16,9-18,9	17	23	2,4	---	---
2514122	750	1017	103,7	---	---	---	90-100	122-135	16,9-18,9	17	23	2,4	---	---

CLARK

CYLINDER SPECIFICATIONS (ORIGINAL DIMENSIONS)

Cylinder Number	Rod Diameter		Tube Bore		Cap or Sleeve Bore		Stroke	
	in	mm	in	mm	in	mm	in	mm

55B STEER

1508904	1.753-1.750	44,526-44,450	3.530-3.525	89,66-89,54	1.757-1.755	44,627-44,577	16.00	406,4
2518802	1.753-1.750	44,526-44,450	3.530-3.525	89,66-89,54	1.757-1.755	44,627-44,577	16.00	406,4
2532705	1.753-1.750	44,526-44,450	3.530-3.525	89,66-89,54	1.757-1.755	44,627-44,577	16.00	406,4

55C BOOM

2523872	2.253-2.250	57,226-57,150	5.030-5.025	127,76-127,64	2.258-2.256	57,35-57,30	27.17	690
2523873	2.253-2.250	57,226-57,150	5.030-5.025	127,76-127,64	2.258-2.256	57,35-57,30	27.17	690

55C BUCKET

2523950	2.003-2.000	50,876-50,800	4.030-4.025	102,36-102,24	2.008-2.006	51,00-50,95	25.79	665
2523951	2.003-2.000	50,876-50,800	4.030-4.025	102,36-102,24	2.008-2.006	51,00-50,95	25.79	665
2526667	2.003-2.000	50,876-50,800	4.030-4.025	102,36-102,24	2.008-2.006	51,00-50,95	25.79	665
2526668	2.003-2.000	50,876-50,800	4.030-4.025	102,36-102,24	2.008-2.006	51,00-50,95	25.79	665

55C STEER

2526859	1.250-1.247	31,750-31,674	2.530-2.525	64,26-64,14	1.255-1.253	31,87-31,83	14.02	356
---------	-------------	---------------	-------------	-------------	-------------	-------------	-------	-----

75B BOOM

962702	2.253-2.250	57,226-57,150	5.030-5.025	127,76-127,64	---	---	34.20	868,7
962703	2.253-2.250	57,226-57,150	5.030-5.025	127,76-127,64	---	---	34.20	868,7
1518977	2.253-2.250	57,226-57,150	5.030-5.025	127,76-127,64	2.258-2.256	57,353-57,503	34.20	868,7
1518978	2.253-2.250	57,226-57,150	5.030-5.025	127,76-127,64	2.258-2.256	57,353-57,503	34.20	868,7
1546056	2.253-2.250	57,226-57,150	5.030-5.025	127,76-127,64	2.258-2.256	57,353-57,303	34.20	868,7
1546057	2.253-2.250	57,226-57,150	5.030-5.025	127,76-127,64	2.258-2.256	57,353-57,303	34.20	868,7
2514111	2.253-2.250	57,226-57,150	5.030-5.025	127,76-127,64	2.258-2.256	57,353-57,303	34.20	868,7
2514122	2.253-2.250	57,226-57,150	5.030-5.025	127,76-127,64	2.258-2.256	57,353-57,303	34.20	868,7
2518075	2.253-2.250	57,226-57,150	5.030-5.025	127,76-127,64	2.258-2.256	57,353-57,303	34.20	868,7
2518076	2.253-2.250	57,226-57,150	5.030-5.025	127,76-127,64	2.258-2.256	57,353-57,303	34.20	868,7
2527513	2.253-2.250	57,226-57,150	5.030-5.025	127,76-127,64	2.258-2.256	57,353-57,303	35.10	891,5
2527549	2.253-2.250	57,226-57,150	5.030-5.025	127,76-127,64	2.258-2.256	57,353-57,303	35.10	891,5
2528565	2.253-2.250	57,226-57,150	5.030-5.025	127,76-127,64	2.258-2.256	57,353-57,303	35.10	891,5
2528566	2.253-2.250	57,226-57,150	5.030-5.025	127,76-127,64	2.258-2.256	57,353-57,303	35.10	891,5

75B BUCKET

964581	2.253-2.250	57,226-57,150	5.030-5.025	127,76-127,64	---	---	15.74	399,8
1511554	2.003-2.000	50,876-50,800	4.280-4.275	108,71-108,59	2.008-2.006	51,003-50,953	15.74	399,8
2518071	2.003-2.000	50,876-50,800	4.280-4.275	108,71-108,59	2.008-2.006	51,003-50,953	15.74	399,8
2520412	2.253-2.250	57,226-57,150	5.030-5.025	127,76-127,64	2.258-2.256	57,353-57,303	15.74	399,8
2532204	2.253-2.250	57,226-57,150	5.030-5.025	127,76-127,64	2.258-2.256	57,353-57,303	15.74	399,8

75B STEER

1508904	1.753-1.750	44,526-44,450	3.530-3.525	89,66-89,54	1.757-1.755	44,627-44,577	16.00	406,4
2518802	1.753-1.750	44,526-44,450	3.530-3.525	89,66-89,54	1.757-1.755	44,627-44,577	16.00	406,4
2532705	1.753-1.750	44,526-44,450	3.530-3.525	89,66-89,54	1.757-1.755	44,627-44,577	16.00	406,4

LF 75B BOOM

1546056	2.253-2.250	57,226-57,150	5.030-5.025	127,76-127,64	2.258-2.256	57,353-57,303	34.20	868,7
1546057	2.253-2.250	57,226-57,150	5.030-5.025	127,76-127,64	2.258-2.256	57,353-57,303	34.20	868,7
2514111	2.253-2.250	57,226-57,150	5.030-5.025	127,76-127,64	2.258-2.256	57,353-57,303	34.20	868,7
2514122	2.253-2.250	57,226-57,150	5.030-5.025	127,76-127,64	2.258-2.256	57,353-57,303	34.20	868,7

CLARK

ASSEMBLY SPECIFICATIONS

Cylinder Number	Piston Nut Torque			Piston Lock Bolt Torque (Threaded Pistons Only)			Cylinder Cap Bolt Torque			Retainer Ring Bolt Torque			Piston to Center of Rod Eye Dimension	
	lb-ft	N·m	kgf·m	lb-ft	N·m	kgf·m	lb-ft	N·m	kgf·m	lb-ft	N·m	kgf·m	in	mm

LF 75B BUCKET

1511554	400	542	55,3	---	---	---	210	285	29,0	17	23	2,4	---	---
---------	-----	-----	------	-----	-----	-----	-----	-----	------	----	----	-----	-----	-----

LF 75B STEER

1508904	400	542	55,3	---	---	---	---	---	---	7	9,5	,97	---	---
2518802	---	---	---	20	27	2,8	---	---	---	4	5,4	,55	20.98	532,9

75C BOOM

2528565	---	---	---	18-20	24-27	2,5-2,8	90-100	122-135	16,9-18,9	35-40	48-54	4,8-5,5	40.80	1036,3
2528566	---	---	---	18-20	24-27	2,5-2,8	90-100	122-135	16,9-18,9	35-40	48-54	4,8-5,5	40.80	1036,3
2536734	---	---	---	18-20	24-27	2,5-2,8	90-100	122-135	16,9-18,9	35-40	48-54	4,8-5,5	40.80	1036,3
2536739	---	---	---	18-20	24-27	2,5-2,8	90-100	122-135	16,9-18,9	35-40	48-54	4,8-5,5	40.80	1036,3
2541827	---	---	---	18-20	24-27	2,5-2,8	90-100	122-135	16,9-18,9	35-40	48-54	4,8-5,5	40.80	1036,3
2541828	---	---	---	18-20	24-27	2,5-2,8	90-100	122-135	16,9-18,9	35-40	48-54	4,8-5,5	40.80	1036,3

75C BUCKET

2529648	---	---	---	18-20	24-27	2,5-2,8	---	---	---	9-10	13-14	1,2-1,4	27.48	698
2541652	---	---	---	18-20	24-27	2,5-2,8	---	---	---	---	---	---	27.48	698,0

75C STEER

2518802	---	---	---	20	27	2,8	---	---	---	4	5,4	,55	20.98	532,9
2529205	---	---	---	---	---	---	475-525	645-710	65,7-72,6	---	---	---	20.96	532,4
2541853	---	---	---	18-20	24-27	2,5-2,8	---	---	---	---	---	---	20.96	532,4

125B BOOM

964597	1000	1356	138,3	---	---	---	175-190	240-260	24,2-26,3	90-100	122-135	16,9-18,9	---	---
964598	1000	1356	138,3	---	---	---	175-190	240-260	24,2-26,3	90-100	122-135	16,9-18,9	---	---
1519174	1000	1356	138,3	---	---	---	168	228	23,2	42	57	5,8	---	---
1519175	1000	1356	138,3	---	---	---	168	228	23,2	42	57	5,8	---	---
2517389	1000	1356	138,3	---	---	---	175-190	240-260	24,2-26,3	42	57	5,8	---	---
2517390	1000	1356	138,3	---	---	---	175-190	240-260	24,2-26,3	42	57	5,8	---	---
2528568	1000	1356	138,3	---	---	---	175-190	240-260	24,2-26,3	90-100	122-135	16,9-18,9	---	---
2528570	1000	1356	138,3	---	---	---	175-190	240-260	24,2-26,3	90-100	122-135	16,9-18,9	---	---

125B BUCKET

964578	1000	1356	138,3	---	---	---	300-330	410-450	41,5-45,6	17	23	2,4	---	---
1519173	1000	1356	138,3	---	---	---	320	434	44,2	17	23	2,4	---	---
2517395	1000	1356	138,3	---	---	---	300-330	410-450	41,5-45,6	17	23	2,4	---	---

125B STEER

2501171	800	1085	110,6	---	---	---	---	---	---	18-20	24-27	2,5-2,8	---	---
2518871	---	---	---	20	27	2,8	---	---	---	4	5,4	,55	26.16	664,5
2532427	---	---	---	18-20	24-27	2,5-2,7	---	---	---	9-10	13-14	1,2-1,4	26.16	664,5

125C BOOM

2528982	---	---	---	18-20	24-27	2,5-2,8	175-190	240-260	24,2-26,3	90-100	122-135	16,9-18,9	46.00	1168,4
2528983	---	---	---	18-20	24-27	2,5-2,8	175-190	240-260	24,2-26,3	90-100	122-135	16,9-18,9	46.00	1168,4
2541356	---	---	---	18-20	24-27	2,5-2,8	175-190	240-260	24,2-26,3	90-100	122-135	16,9-18,9	46.00	1168,4
2541357	---	---	---	18-20	24-27	2,5-2,8	175-190	240-260	24,2-26,3	90-100	122-135	16,9-18,9	46.00	1168,4

CLARK

CYLINDER SPECIFICATIONS (ORIGINAL DIMENSIONS)

Cylinder Number	Rod Diameter		Tube Bore		Cap or Sleeve Bore		Stroke	
	in	mm	in	mm	in	mm	in	mm

LF 75B BUCKET

1511554	2.003-2.000	50,876-50,800	4.280-4.275	108,71-108,59	2.008-2.006	51,003-50,953	15.74	399,8
---------	-------------	---------------	-------------	---------------	-------------	---------------	-------	-------

LF 75B STEER

1508904	1.753-1.750	44,526-44,450	3.530-3.525	89,66-89,54	1.757-1.755	44,63-44,58	16.00	406,4
2518802	1.753-1.750	44,526-44,450	3.530-3.525	89,66-89,54	1.757-1.755	44,63-44,58	16.00	406,4

75C BOOM

2528565	2.253-2.250	57,226-57,150	5.030-5.025	127,76-127,64	2.258-2.256	57,353-57,303	35.10	891,5
2528566	2.253-2.250	57,226-57,150	5.030-5.025	127,76-127,64	2.258-2.256	57,353-57,303	35.10	891,5
2536734	2.253-2.250	57,226-57,150	5.030-5.025	127,76-127,64	2.258-2.256	57,353-57,303	35.10	891,5
2536739	2.253-2.250	57,226-57,150	5.030-5.025	127,76-127,64	2.258-2.256	57,353-57,303	35.10	891,5
2541827	2.253-2.250	57,226-57,150	5.030-5.025	127,76-127,64	---	---	35.10	891,5
2541828	2.253-2.250	57,226-57,150	5.030-5.025	127,76-127,64	---	---	35.10	891,5

75C BUCKET

2529648	2.750-2.747	69,850-69,774	5.030-5.025	127,76-127,64	2.7550-2.7526	69,977-69,916	15.74	399,8
2541652	2.750-2.747	69,850-69,774	5.030-5.025	127,76-127,64	2.7550-2.7526	69,977-69,916	15.74	399,8

75C STEER

2518802	1.753-1.750	44,526-44,450	3.530-3.525	89,66-89,54	1.757-1.755	44,627-44,577	16.00	406,4
2529205	1.750-1.747	44,450-44,374	3.530-3.525	89,66-89,54	1.755-1.753	44,577-44,526	16.00	406,4
2541853	1.750-1.747	44,450-44,374	3.530-3.525	89,66-89,54	1.755-1.753	44,577-44,526	16.00	406,4

125B BOOM

964597	2.753-2.750	69,926-69,850	6.030-6.025	153,16-153,04	---	---	39.30	998,2
964598	2.753-2.750	69,926-69,850	6.030-6.025	153,16-153,04	---	---	39.30	998,2
1519174	2.753-2.750	69,926-69,850	6.030-6.025	153,16-153,04	2.758-2.756	70,053-70,003	39.30	998,2
1519175	2.753-2.750	69,926-69,850	6.030-6.025	153,16-153,04	2.758-2.756	70,053-70,003	39.30	998,2
2517389	2.753-2.750	69,926-69,850	6.030-6.025	153,16-153,04	2.758-2.756	70,053-70,003	39.30	998,2
2517390	2.753-2.750	69,926-69,850	6.030-6.025	153,16-153,04	2.758-2.756	70,053-70,003	39.30	998,2
2528568	2.753-2.750	69,926-69,850	6.030-6.025	153,16-153,04	2.758-2.756	70,053-70,003	39.30	998,2
2528570	2.753-2.750	69,926-69,850	6.030-6.025	153,16-153,04	2.758-2.756	70,053-70,003	39.30	998,2

125B BUCKET

964578	2.253-2.250	57,226-57,150	4.530-4.525	115,06-114,94	---	---	24.70	627,4
1519173	2.253-2.250	57,226-57,150	4.530-4.525	115,06-114,94	2.258-2.256	57,353-57,303	24.70	627,4
2517395	2.253-2.250	57,226-57,150	4.530-4.525	115,06-114,94	2.258-2.256	57,353-57,303	24.70	627,4

125B STEER

2501171	1.753-1.750	44,526-44,450	3.530-3.525	89,66-89,54	1.757-1.755	44,627-44,577	20.30	515,6
2518871	1.753-1.750	44,526-44,450	3.530-3.525	89,66-89,54	1.757-1.755	44,627-44,577	20.30	515,6
2532427	1.753-1.750	44,526-44,450	3.530-3.525	89,66-89,54	1.757-1.755	44,627-44,577	20.30	515,6

125C BOOM

2528982	2.750-2.747	69,850-69,774	6.030-6.025	153,16-153,04	2.7550-2.7526	69,977-69,916	39.30	998,2
2528983	2.750-2.747	69,850-69,774	6.030-6.025	153,16-153,04	2.7550-2.7526	69,977-69,916	39.30	998,2
2541356	2.750-2.747	69,850-69,774	6.030-6.025	153,16-153,04	---	---	39.30	998,2
2541357	2.750-2.747	69,850-69,774	6.030-6.025	153,16-153,04	---	---	39.30	998,2

CLARK

ASSEMBLY SPECIFICATIONS

Cylinder Number	Piston Nut Torque			Piston Lock Bolt Torque (Threaded Pistons Only)			Cylinder Cap Bolt Torque			Retainer Ring Bolt Torque			Piston to Center of Rod Eye Dimension	
	lb•ft	N•m	kgf•m	lb•ft	N•m	kgf•m	lb•ft	N•m	kgf•m	lb•ft	N•m	kgf•m	in	mm

125C BUCKET

2525298	---	---	---	18-20	24-27	2,5-2,7	---	---	---	9-10	13-14	1,2-1,4	39.82	1011
2532213	---	---	---	18-20	24-27	2,5-2,7	---	---	---	9-10	13-14	1,2-1,4	39.80	1011
2541648	---	---	---	18-20	24-27	2,5-2,7	---	---	---	---	---	---	39.80	1010,9

125C STEER

2525743	---	---	---	18-20	24-27	2,5-2,7	---	---	---	---	---	---	25.76	654,3
2541852	---	---	---	18-20	24-27	2,5-2,7	---	---	---	---	---	---	25.76	654,3

175B BOOM

964596	1000	1356	138,3	---	---	---	300-330	410-450	41,5-45,6	90-100	122-135	16,9-18,9	---	---
1518400	1000	1356	138,3	---	---	---	300	410	41,5	42	57	5,8	---	---
2518119	1000	1356	138,3	---	---	---	300-330	410-450	41,5-45,6	42	57	5,8	---	---
2528567	1000	1356	138,3	---	---	---	300-330	410-450	41,5-45,6	90-100	122-135	16,9-18,9	---	---

175B BUCKET

964575	1000	1356	138,3	---	---	---	475-525	645-710	65,7-72,6	42	57	5,8	---	---
1511622	1000	1356	138,3	---	---	---	320	434	44,2	42	57	5,8	---	---
1517851	1000	1356	138,3	---	---	---	505	685	69,8	42	57	5,8	---	---
2518125	1000	1356	138,3	---	---	---	475-525	645-710	65,7-72,6	42	57	5,8	---	---
2523731	1000	1356	138,3	---	---	---	475-525	645-710	65,7-72,6	90-100	122-135	16,9-18,9	---	---
2524276	---	---	---	18-20	24-27	2,5-2,7	475-525	645-710	65,7-72,6	90-100	122-135	16,9-18,9	38.12	968,2
2541789	---	---	---	18-20	24-27	2,5-2,7	475-525	645-710	65,7-72,6	90-100	122-135	16,9-18,9	38.12	968,2

175B STEER

1511641	750	1017	103,7	---	---	---	90	122	16,9	17	23	2,4	---	---
2518117	750	1017	103,7	---	---	---	90-100	122-135	16,9-18,9	17	23	2,4	---	---
2532353	750	1017	103,7	---	---	---	90-100	122-135	16,9-18,9	35-40	48-54	4,8-5,5	---	---

175C BOOM

2524467	---	---	---	18-20	24-27	2,5-2,7	300-330	410-450	41,5-45,6	90-100	122-135	16,9-18,9	51.34	1304,0
2541925	---	---	---	18-20	24-27	2,5-2,7	300-330	410-450	41,5-45,6	90-100	122-135	16,9-18,9	51.34	1304,0

175C BUCKET

2524276	---	---	---	18-20	24-27	2,5-2,7	475-525	645-710	65,7-72,6	90-100	122-135	16,9-18,9	38.12	968,2
2541789	---	---	---	18-20	24-27	2,5-2,7	475-525	645-710	65,7-72,6	90-100	122-135	16,9-18,9	38.12	968,2

175C STEER

2528848	---	---	---	18-20	24-27	2,5-2,7	---	---	---	9-10	13-14	1,2-1,4	26.32	668,5
2541510	---	---	---	18-20	24-27	2,5-2,7	---	---	---	---	---	---	26.32	668,5

275B BOOM

964590	1000	1356	138,3	---	---	---	800-825	1085-1119	110,6-114,0	90-100	122-135	16,9-18,9	---	---
1511407	2500	3389	345,6	---	---	---	1058	1434	146,1	42	57	5,8	---	---
1511408	2500	3389	345,6	---	---	---	1058	1434	146,1	42	57	5,8	---	---
1512294	1000	1356	138,3	---	---	---	1058	1435	146,1	42	57	5,8	---	---
1518399	1000	1356	138,3	---	---	---	1058	1435	146,1	42	57	5,8	---	---
2504218	1000	1356	138,3	---	---	---	800-825	1085-1119	110,6-114,0	42	57	5,8	---	---
2528569	1000	1356	138,3	---	---	---	725-800	983-1085	100,2-110,6	90-100	122-135	16,9-18,9	---	---

CLARK

CYLINDER SPECIFICATIONS (ORIGINAL DIMENSIONS)

Cylinder Number	Rod Diameter		Tube Bore		Cap or Sleeve Bore		Stroke	
	in	mm	in	mm	in	mm	in	mm

125C BUCKET

2525298	2.750-2.747	69,850-69,774	5.030-5.025	127,76-127,64	2.7550-2.7526	69,977-69,916	24.70	627,4
2532213	2.750-2.747	69,850-69,774	5.030-5.025	127,76-127,64	2.7550-2.7526	69,977-69,916	24.70	627,4
2541648	2.750-2.747	69,850-69,774	5.030-5.025	127,76-127,64	2.7550-2.7526	69,977-69,916	24.70	627,4

125C STEER

2525743	1.750-1.747	44,450-44,374	3.530-3.525	89,66-89,54	1.7550-1.7526	44,577-44,516	20.30	515,6
2541852	1.750-1.747	44,450-44,374	3.530-3.525	89,66-89,54	1.7550-1.7526	44,577-44,516	20.30	515,6

175B BOOM

964596	2.753-2.750	69,926-69,850	7.030-7.025	178,56-178,44	—	—	42.70	1084,6
1518400	2.753-2.750	69,926-69,850	7.030-7.025	178,56-178,44	2.758-2.756	70,053-70,003	42.70	1084,6
2518119	2.753-2.750	69,926-69,850	7.030-7.025	178,56-178,44	2.758-2.756	70,053-70,003	42.70	1084,6
2528567	2.753-2.750	69,926-69,850	7.030-7.025	178,56-178,44	2.758-2.756	70,053-70,003	42.70	1084,6

175B BUCKET

964575	2.753-2.750	69,926-69,850	6.030-6.025	153,16-153,04	2.758-2.756	70,05-70,00	23.62	600,0
1511622	2.753-2.750	69,926-69,850	6.030-6.025	153,16-153,04	2.758-2.756	70,053-70,003	23.62	600,0
1517851	2.753-2.750	69,926-69,850	6.030-6.025	153,16-153,04	2.758-2.756	70,053-70,003	23.62	600,0
2518125	2.753-2.750	69,926-69,850	6.030-6.025	153,16-153,04	2.758-2.756	70,053-70,003	23.62	600,0
2523731	2.753-2.750	69,926-69,850	6.030-6.025	153,16-153,04	2.758-2.756	70,053-70,003	23.62	600,0
2524276	2.750-2.747	69,850-69,774	6.030-6.025	153,16-153,04	2.755-2.754	69,977-69,952	23.62	600,0
2541789	2.750-2.747	69,850-69,774	6.030-6.025	153,16-153,04	—	—	23.62	600,0

175B STEER

1511641	2.003-2.000	50,876-50,800	4.530-4.525	115,06-114,94	2.008-2.006	51,003-50,953	18.50	469,9
2518117	2.003-2.000	50,876-50,800	4.530-4.525	115,06-114,94	2.008-2.006	51,003-50,953	18.50	469,9
2532353	2.003-2.000	50,876-50,800	4.530-4.525	115,06-114,94	2.008-2.006	51,003-50,953	18.50	469,9

175C BOOM

2524467	3.000-2.997	76,200-76,124	7.030-7.025	178,56-178,44	3.0050-3.0026	76,327-76,266	42.70	1084,6
2541925	3.000-2.997	76,200-76,124	7.030-7.025	178,56-178,44	—	—	42.70	1084,6

175C BUCKET

2524276	2.750-2.747	69,850-69,774	6.030-6.025	153,16-153,04	2.7550-2.7536	69,977-69,916	23.62	600,0
2541789	2.750-2.747	69,850-69,774	6.030-6.025	153,16-153,04	—	—	23.62	600,0

175C STEER

2528848	2.250-2.247	57,150-57,074	4.530-4.525	115,06-114,94	2.2550-2.2526	57,277-57,216	19.96	507
2541510	2.250-2.247	57,150-57,074	4.530-4.525	115,06-114,94	2.2550-2.2526	57,277-57,216	19.96	507

275B BOOM

964590	3.500-3.497	88,900-88,824	9.045-9.040	229,74-229,62	—	—	44.90	1140,5
1511407	3.500-3.497	88,900-88,824	9.045-9.040	229,74-229,62	3.505-3.503	89,027-88,977	44.88	1140,0
1511408	3.500-3.497	88,900-88,824	9.045-9.040	229,74-229,62	3.505-3.503	89,027-88,977	44.88	1140,0
1512294	3.500-3.497	88,900-88,824	9.045-9.040	229,74-229,62	3.505-3.503	89,027-88,977	44.90	1140,5
1518399	3.500-3.497	88,900-88,824	9.045-9.040	229,74-229,62	3.505-3.503	89,027-88,977	44.90	1140,5
2504218	3.500-2.497	88,900-88,824	9.045-9.040	229,74-229,62	3.505-3.503	89,027-88,977	44.90	1140,5
2528569	3.500-3.497	88,900-88,824	9.045-9.040	229,74-229,62	3.506-3.504	89,052-89,002	44.90	1140,5

CLARK

ASSEMBLY SPECIFICATIONS

Cylinder Number	Piston Nut Torque			Piston Lock Bolt Torque (Threaded Pistons Only)			Cylinder Cap Bolt Torque			Retainer Ring Bolt Torque			Piston to Center of Rod Eye Dimension	
	lb·ft	N·m	kgf·m	lb·ft	N·m	kgf·m	lb·ft	N·m	kgf·m	lb·ft	N·m	kgf·m	in	mm

275B BUCKET

964573	1000	1356	138,3	---	---	---	475-525	645-710	65,7-72,6	90-100	122-135	16,9-18,9	---	---
1509395	1000	1356	138,3	---	---	---	505	685	69,8	90-100	122-135	16,9-18,9	---	---
1513815	1000	1356	138,3	---	---	---	505	685	69,8	42	57	5,8	---	---
2516176	1000	1356	138,3	---	---	---	475-525	645-710	65,7-72,6	42	57	5,8	---	---
2532534	1000	1356	138,3	---	---	---	475-525	645-710	65,7-72,6	90-100	122-135	16,9-18,9	---	---

275B STEER

1511749	1000	1356	138,3	---	---	---	185	251	25,6	17	23	2,4	---	---
1538181	1000	1356	138,3	---	---	---	185	251	25,6	90-100	122-135	16,9-18,9	---	---
2516160	1000	1356	138,3	---	---	---	175-190	240-260	24,2-26,3	17	23	2,4	---	---
2532606	1000	1356	138,3	---	---	---	175-190	240-260	24,2-26,3	17	23	2,4	---	---

275C BOOM

2525863	---	---	---	18-20	24-27	2,5-2,7	1475-1625	2000-2200	203,9-224,6	90-100	122-135	16,9-18,9	53.50	1358,9
2541292	---	---	---	18-20	24-27	2,5-2,7	---	---	---	90-100	122-135	16,9-18,9	53.50	1358,9

275C BUCKET

2529399	---	---	---	18-20	24-27	2,5-2,7	725-800	985-1085	100,2-110,6	90-100	122-135	16,9-18,9	35.86	910,8
2541297	---	---	---	18-20	24-27	2,5-2,7	725-800	985-1085	100,2-110,6	90-100	122-135	16,9-18,9	35.86	910,8

275C STEER

2529566	---	---	---	18-20	24-27	2,5-2,7	---	---	---	9-10	13-14	1,2-1,4	23.36	593,3
2541515	---	---	---	18-20	24-27	2,5-2,7	---	---	---	---	---	---	23.36	593,3

475B BOOM

964569	2000	2712	276,5	---	---	---	1475-1625	2000-2200	203,9-224,6	100	135	18,9	---	---
1515037	2000	2712	276,5	---	---	---	1500	2034	207,4	42	57	5,8	---	---
1518699	2000	2712	276,5	---	---	---	1500	2034	207,4	42	57	5,8	---	---
2514095	2000	2712	276,5	---	---	---	1475-1625	2000-2200	203,9-224,6	100	135	18,9	---	---

475B BUCKET

964589	2000	2712	276,5	---	---	---	1475-1625	2000-2200	203,9-224,6	100	135	18,9	---	---
2514104	2000	2712	276,5	---	---	---	1475-1625	2000-2200	203,9-224,6	100	135	18,9	---	---

475B STEER

1503659	1000	1356	138,3	---	---	---	153	207	28,6	FINGER TIGHTEN			---	---
2514101	1000	1356	138,3	---	---	---	---	---	---	100	135	18,9	---	---

475C BOOM

2528161	---	---	---	35-40	48-54	6,6-7,5	2600-2850	3530-3870	359,5-394,0	90-100	122-135	16,9-18,9	69.88	1775
2541330	---	---	---	35-40	48-54	6,6-7,5	2600-2850	3530-3870	359,5-394,0	90-100	122-135	16,9-18,9	69.88	1775

475C BUCKET

2524053	---	---	---	18-20	24-27	2,5-2,7	1475-1625	2000-2200	203,9-224,6	90-100	122-135	16,9-18,9	58.30	1480,8
2541265	---	---	---	18-20	24-27	2,5-2,7	---	---	---	90-100	122-135	16,9-18,9	58.30	1480,8

CLARK

CYLINDER SPECIFICATIONS (ORIGINAL DIMENSIONS)

Cylinder Number	Rod Diameter		Tube Bore		Cap or Sleeve Bore		Stroke	
	in	mm	in	mm	in	mm	in	mm

275B BUCKET

964573	2.753-2.750	69,926-69,850	7.030-7.025	178,56-178,44	2.758-2.756	70,05-70,00	25.50	647,7
1509395	2.753-2.750	69,926-69,850	7.030-7.025	178,56-178,44	2.759-2.755	70,07-69,97	25.50	647,7
1513815	2.753-2.750	69,926-69,850	7.030-7.025	178,56-178,44	2.758-2.756	70,05-70,00	25.50	647,7
2516176	2.753-2.750	69,926-69,850	7.030-7.025	178,56-178,44	2.758-2.756	70,05-70,00	25.50	647,7
2532534	2.753-2.750	69,926-69,850	7.030-7.025	178,56-178,44	2.758-2.756	70,05-70,00	25.50	647,7

275B STEER

1511749	2.253-2.250	57,226-57,150	5.280-5.275	134,11-133,99	2.258-2.256	57,353-57,303	17.00	431,8
1538181	2.250-2.248	57,150-57,100	5.280-5.275	134,11-133,99	2.258-2.256	57,353-57,303	16.50	419,1
2516160	2.253-2.250	57,226-57,150	5.280-5.275	134,11-133,99	2.258-2.256	57,353-57,303	17.00	431,8
2532606	2.253-2.250	57,226-57,150	5.280-5.275	134,11-133,99	2.258-2.256	57,353-57,303	17.00	431,8

275C BOOM

2525863	4.000-3.997	101,600-101,524	9.045-9.040	229,74-229,62	4.0050-4.0026	101,727-101,666	44.90	1140,5
2541292	4.000-3.997	101,600-101,524	9.045-9.040	229,74-229,62	---	---	44.90	1140,5

275C BUCKET

2729399	2.750-2.747	69,850-69,774	7.030-7.025	178,56-178,44	2.7550-2.7526	69,977-69,916	25.50	647,7
2541297	2.750-2.747	69,850-69,774	7.030-7.025	178,56-178,44	---	---	25.50	647,7

275C STEER

2529566	2.250-2.247	57,150-57,074	4.530-4.525	115,06-114,94	2.2550-2.2526	57,277-57,216	17.00	431,8
2541515	2.250-2.247	57,150-57,074	4.530-4.525	115,06-114,94	2.2550-2.2526	57,277-57,216	17.00	431,8

475B BOOM

964569	4.500-4.497	114,300-114,224	10.545-10.540	267,84-267,72	---	---	58.38	1482,8
1515037	4.500-4.497	114,300-114,224	10.545-10.540	267,84-267,72	4.505-4.503	114,427-114,377	58.38	1482,8
1518699	4.500-4.497	114,300-114,224	10.545-10.540	267,84-267,72	4.505-4.503	114,427-114,377	58.38	1482,8
2514095	4.500-4.497	114,300-114,224	10.545-10.540	267,84-267,72	4.505-4.503	114,427-114,377	58.38	1482,8

475B BUCKET

964589	4.500-4.497	114,300-114,224	9.045-9.040	229,74-229,62	---	---	72.00	1828,8
2514104	4.500-4.497	114,300-114,224	9.045-9.040	229,74-229,62	4.505-4.503	114,427-114,377	72.00	1828,8

475B STEER

1503659	2.753-2.750	69,926-69,850	7.030-7.025	178,56-178,44	2.760-2.757	70,104-70,028	29.25	743,0
2514101	2.753-2.750	69,926-69,850	7.030-7.025	178,56-178,44	2.758-2.756	70,05-70,00	29.25	743,0

475C BOOM

2528161	5.000-4.997	127,000-126,924	10.545-10.540	267,84-267,72	5.005-5.003	127,127-127,077	58.38	1482,8
2541330	5.000-4.997	127,000-126,924	10.545-10.540	267,84-267,72	---	---	58.38	1482,8

475C BUCKET

2524053	4.500-4.497	114,300-114,224	9.045-9.040	229,74-229,62	4.505-4.503	114,427-114,377	33.40	848,4
2541265	4.500-4.497	114,300-114,224	9.045-9.040	229,74-229,62	---	---	33.40	848,4

CLARK

ASSEMBLY SPECIFICATIONS

Cylinder Number	Piston Nut Torque			Piston Lock Bolt Torque (Threaded Pistons Only)			Cylinder Cap Bolt Torque			Retainer Ring Bolt Torque			Piston to Center of Rod Eye Dimension	
	lb-ft	N·m	kgf·m	lb-ft	N·m	kgf·m	lb-ft	N·m	kgf·m	lb-ft	N·m	kgf·m	in	mm

475C STEER

2527900	---	---	---	18-20	24-27	2,5-2,7	475-525	645-710	65,7-72,6	90-100	122-135	16,9-18,9	42.26	1073,4
2536980	---	---	---	18-20	24-27	2,5-2,7	475-525	645-710	65,7-72,6	90-100	122-135	16,9-18,9	42.26	1073,4
2541333	---	---	---	18-20	24-27	2,5-2,7	---	---	---	90-100	122-135	16,9-18,9	42.26	1073,4

675B BOOM

2526276	---	---	---	35-40	48-54	6,6-7,5	2600-2800	3530-3870	359,5-394,0	90-100	122-135	16,9-18,9	86.50	2197
---------	-----	-----	-----	-------	-------	---------	-----------	-----------	-------------	--------	---------	-----------	-------	------

675B BUCKET

2526097	---	---	---	35-40	48-54	6,6-7,5	2600-2850	3530-3870	359,5-394,0	90-100	122-135	16,9-18,9	71.00	1803
---------	-----	-----	-----	-------	-------	---------	-----------	-----------	-------------	--------	---------	-----------	-------	------

675B STEER

1512049	2000	2712	276,5	---	---	---	1058	1435	146,1	42	57	5,8	---	---
---------	------	------	-------	-----	-----	-----	------	------	-------	----	----	-----	-----	-----

675C BOOM

2526276	---	---	---	35-40	48-54	6,6-7,5	2600-2800	3530-3870	359,5-394,0	90-100	122-135	16,9-18,9	86.50	2197
---------	-----	-----	-----	-------	-------	---------	-----------	-----------	-------------	--------	---------	-----------	-------	------

675C BUCKET

2526097	---	---	---	35-40	48-54	6,6-7,5	2600-2800	3530-3870	359,5-394,0	90-100	122-135	16,9-18,9	71.00	1803
---------	-----	-----	-----	-------	-------	---------	-----------	-----------	-------------	--------	---------	-----------	-------	------

675C STEER

2527211	---	---	---	18-20	24-27	2,5-2,7	475-525	645-710	65,7-72,6	90-100	122-135	16,9-18,9	48.50	1232
---------	-----	-----	-----	-------	-------	---------	---------	---------	-----------	--------	---------	-----------	-------	------

280 III A STEER

569968	1000	1356	138,3	---	---	---	185	250	25,6	FINGER TIGHTEN			---	---
1503241	1000	1356	138,3	---	---	---	185	250	25,6	FINGER TIGHTEN			---	---
1515236	1000	1356	138,3	---	---	---	175-190	240-260	24,2-26,3	FINGER TIGHTEN			---	---
2522932	1500	2034	207,4	---	---	---	175-190	240-260	24,2-26,3	35-40	48-54	4,8-5,5	---	---

280 III A TILT

964662	1500	2034	207,4	---	---	---	175-190	240-260	24,2-26,3	35-40	48-54	4,8-5,5	---	---
1503606	1500	2034	207,4	---	---	---	175-190	240-260	24,2-26,3	FINGER TIGHTEN			---	---
1524035	2000	2712	276,5	---	---	---	105	142	14,5	FINGER TIGHTEN			---	---
1530853	1500	2034	207,4	---	---	---	185	250	25,6	FINGER TIGHTEN			---	---
2522880	1500	2034	207,4	---	---	---	175-190	240-260	24,2-26,3	35-40	48-54	4,8-5,5	---	---

280 III A PITCH

964665	1500	2034	207,4	---	---	---	175-190	240-260	24,2-26,3	35-40	48-54	4,8-5,5	---	---
1503609	1500	2034	207,4	---	---	---	90-100	122-135	16,9-18,9	FINGER TIGHTEN			---	---
1527870	1500	2034	207,4	---	---	---	50	68	6,9	FINGER TIGHTEN			---	---
2523004	1500	2034	207,4	---	---	---	175-190	240-260	24,2-26,3	35-40	48-54	4,8-5,5	---	---

280 III A LIFT

962698	1500	2034	207,4	---	---	---	175-190	240-260	24,2-26,3	90-100	125-135	16,9-18,9	---	---
1503604	1500	2034	207,4	---	---	---	90-100	122-135	16,9-18,9	FINGER TIGHTEN			---	---
1503605	1500	2034	207,4	---	---	---	185	250	25,6	FINGER TIGHTEN			---	---
1530505	1500	2034	207,4	---	---	---	185	250	25,6	FINGER TIGHTEN			---	---
2522607	1500	2034	207,4	---	---	---	175-190	240-260	24,2-26,3	90-100	122-135	16,9-18,9	---	---

CLARK

CYLINDER SPECIFICATIONS (ORIGINAL DIMENSIONS)

Cylinder Number	Rod Diameter		Tube Bore		Cap or Sleeve Bore		Stroke	
	in	mm	in	mm	in	mm	in	mm
475C STEER								
2527900	2.750-2.747	69,850-69,774	6.030-6.025	153,16-153,04	2.755-2.753	69,977-69,926	23.80	604,5
2536980	2.750-2.747	69,850-69,774	6.030-6.025	153,16-153,04	2.755-2.753	69,977-69,926	23.80	604,5
2541333	2.750-2.747	69,850-69,774	6.030-6.025	153,16-153,04	—	—	23.80	604,5
675B BOOM								
2526276	5.500-5.497	139,70-139,60	10.545-10.540	267,84-267,72	5.505-5.503	139,9-139,8	72.00	1828,8
675B BUCKET								
2526097	5.000-4.997	127,00-126,90	10.545-10.540	267,84-267,72	5.005-5.003	127,127-127,077	54.60	1386,8
675B STEER								
1512049	3.500-3.497	88,900-88,824	8.045-8.040	204,34-204,22	3.505-3.503	89,027-88,977	35.50	901,7
675C BOOM								
2526276	5.500-5.497	139,70-139,60	10.545-10.540	267,84-267,72	5.505-5.503	139,9-139,8	72.00	1828,8
675C BUCKET								
2526097	5.000-4.997	127,00-126,90	10.545-10.540	267,84-267,72	5.005-5.003	127,127-127,077	54.60	1386,8
675C STEER								
2527211	3.000-2.997	76,20-76,10	7.030-7.025	178,56-178,44	3.005-3.003	76,327-76,276	35.50	901,7
280 III A STEER								
569968	2.253-2.250	57,226-57,150	5.280-5.275	134,11-133,99	2.260-2.257	57,404-57,328	27.25	692,0
1503241	2.253-2.250	57,226-57,150	5.280-5.275	134,11-133,99	2.260-2.257	57,404-57,328	27.25	692,0
1515236	2.253-2.250	57,226-57,150	5.280-5.275	134,11-133,99	2.260-2.257	57,404-57,328	27.24	691,9
2522932	2.253-2.250	57,226-57,150	5.280-5.275	134,11-133,99	2.258-2.256	57,353-57,303	27.24	691,9
280 III A TILT								
964662	2.253-2.250	57,226-57,150	5.280-5.275	134,11-133,99	—	—	—	—
1503606	2.253-2.250	57,226-57,150	5.280-5.275	134,11-133,99	2.260-2.257	57,404-57,328	9.625	244,5
1524035	2.753-2.750	69,926-69,850	6.030-6.025	153,16-153,04	2.760-2.757	70,104-70,028	9.625	244,5
1530853	2.253-2.250	57,226-57,150	5.280-5.275	134,11-133,99	2.260-2.257	57,404-57,328	9.625	244,5
2522880	2.253-2.250	57,226-57,150	5.280-5.275	134,11-133,99	2.258-2.256	57,353-57,303	9.625	244,5
280 III A PITCH								
964665	2.003-2.000	50,876-50,800	4.530-4.525	115,06-114,94	2.008-2.006	51,00-50,95	15.375	390,5
1503609	2.003-2.000	50,876-50,800	4.530-4.525	115,06-114,94	2.010-2.007	51,054-50,978	15.375	390,5
1527870	2.003-2.000	50,876-50,800	4.530-4.525	115,06-114,94	2.010-2.007	51,054-50,978	15.375	390,5
2523004	2.003-2.000	50,876-50,800	4.530-4.525	115,06-114,94	2.008-2.006	51,00-50,95	15.375	390,5
280 III A LIFT								
962698	2.753-2.750	69,926-69,850	6.030-6.025	153,16-153,04	—	—	35.72	907,3
1503604	2.753-2.750	69,926-69,850	6.030-6.025	153,16-153,04	2.760-2.757	70,104-70,028	35.72	907,3
1503605	2.253-2.250	57,226-57,150	5.280-5.275	134,11-133,99	2.260-2.257	57,404-57,328	35.68	906,4
1530505	2.253-2.250	57,226-57,150	5.280-5.275	134,11-133,99	2.260-2.257	57,404-57,328	35.68	906,4
2522607	2.753-2.750	69,926-69,850	6.030-6.025	153,16-153,04	2.758-2.756	70,053-70,003	35.72	907,3

CLARK

ASSEMBLY SPECIFICATIONS

Cylinder Number	Piston Nut Torque			Piston Lock Bolt Torque (Threaded Pistons Only)			Cylinder Cap Bolt Torque			Retainer Ring Bolt Torque			Piston to Center of Rod Eye Dimension	
	lb·ft	N·m	kgf·m	lb·ft	N·m	kgf·m	lb·ft	N·m	kgf·m	lb·ft	N·m	kgf·m	in	mm

LF280 LIFT

1503605	1500	2034	207,4	---	---	---	185	250	25,6	FINGER TIGHTEN			---	---
---------	------	------	-------	-----	-----	-----	-----	-----	------	----------------	--	--	-----	-----

280B STEER

2528419	---	---	---	18-20	24-27	2,5-2,7	---	---	---	---	---	---	33.80	858,5
---------	-----	-----	-----	-------	-------	---------	-----	-----	-----	-----	-----	-----	-------	-------

280B TILT

964662	1500	2034	207,4	---	---	---	175-190	240-260	24,2-26,3	35-40	48-54	4,8-5,5	---	---
2522880	1500	2034	207,4	---	---	---	175-190	240-260	24,2-26,3	35-40	48-54	4,8-5,5	---	---

280B PITCH

964665	1500	2034	207,4	---	---	---	175-190	240-260	24,2-26,3	35-40	48-54	4,8-5,5	---	---
2523004	1500	2034	207,4	---	---	---	175-190	240-260	24,2-26,3	35-40	48-54	4,8-5,5	---	---

280B LIFT

962698	1500	2034	207,4	---	---	---	175-190	240-260	24,2-26,3	90-100	122-135	16,9-18,9	---	---
1503604	1500	2034	207,4	---	---	---	90-100	122-135	16,9-18,9	FINGER TIGHTEN			---	---
2522607	1500	2034	207,4	---	---	---	175-190	240-260	24,2-26,3	90-100	122-135	16,9-18,9	---	---

380 III A STEER

1528437	1000	1356	138,3	---	---	---	725-800	985-1085	100,2-110,6	FINGER TIGHTEN			---	---
2522598	1000	1356	138,3	---	---	---	475-525	645-710	65,7-72,6	90-100	122-135	16,9-18,9	---	---
2536465	---	---	---	18-20	24-27	2,5-2,7	475-525	645-710	65,7-72,6	90-100	122-135	16,9-18,9	39.20	995,7

380 III A TILT

964577	1500	2034	207,4	---	---	---	175-190	240-260	24,2-26,3	90-100	122-135	16,9-18,9	---	---
1532052	1500	2034	207,4	---	---	---	175-190	240-260	24,2-26,3	FINGER TIGHTEN			---	---
2522120	1500	2034	207,4	---	---	---	175-190	240-260	24,2-26,3	90-100	122-135	16,9-18,9	---	---

380 III A PITCH

964583	1500	2034	207,4	---	---	---	175-190	240-260	24,2-26,3	35-40	48-54	4,8-5,5	---	---
1505457	1500	2034	207,4	---	---	---	175-190	240-260	24,2-26,3	FINGER TIGHTEN			---	---
2522411	1500	2034	207,4	---	---	---	175-190	240-260	24,2-26,3	35-40	48-54	4,8-5,5	---	---

380 III A LIFT

962697	1500	2034	207,4	---	---	---	175-190	240-260	24,2-26,3	90-100	122-135	16,9-18,9	---	---
1510225	1500	2034	207,4	---	---	---	300-330	410-450	41,5-45,6	FINGER TIGHTEN			---	---
2522115	1500	2034	207,4	---	---	---	175-190	240-260	24,2-26,3	90-100	122-135	16,9-18,9	---	---

380B STEER

1528437	1000	1356	138,3	---	---	---	725-800	985-1085	100,2-110,6	FINGER TIGHTEN			---	---
2522598	1000	1356	138,3	---	---	---	475-525	645-710	65,7-72,6	90-100	122-135	16,9-18,9	---	---

380B TILT

964577	1500	2034	207,4	---	---	---	175-190	240-260	24,2-26,3	90-100	122-135	16,9-18,9	---	---
1532052	1500	2034	207,4	---	---	---	175-190	240-260	24,2-26,3	FINGER TIGHTEN			---	---
2522120	1500	2034	207,4	---	---	---	175-190	240-260	24,2-26,3	90-100	122-135	16,9-18,9	---	---

CLARK

CYLINDER SPECIFICATIONS (ORIGINAL DIMENSIONS)

Cylinder Number	Rod Diameter		Tube Bore		Cap or Sleeve Bore		Stroke	
	in	mm	in	mm	in	mm	in	mm

LF280 LIFT

1503605	2.253-2.250	57,226-57,150	5.280-5.275	134,11-133,99	2.260-2.257	57,404-57,328	---	---
---------	-------------	---------------	-------------	---------------	-------------	---------------	-----	-----

280B STEER

2528419	2.250-2.247	57,150-57,100	5.280-5.275	134,11-133,99	2.255-2.253	57,277-57,227	26.12	663,4
---------	-------------	---------------	-------------	---------------	-------------	---------------	-------	-------

280B TILT

964662	2.253-2.250	57,226-57,150	5.280-5.275	134,11-133,99	---	---	9.625	244,5
2522880	2.253-2.250	57,226-57,150	5.280-5.275	134,11-133,99	2.258-2.256	57,353-57,303	9.625	244,5

280B PITCH

964665	2.003-2.000	50,876-50,800	4.530-4.525	115,06-114,94	2.008-2.006	51,00-50,95	15.375	390,5
2523004	2.003-2.000	50,876-50,800	4.530-4.525	115,06-114,94	2.008-2.006	51,00-50,95	15.375	390,5

280B LIFT

962698	2.753-2.750	69,926-69,850	6.030-6.025	153,16-153,04	---	---	35.72	907,3
1503604	2.753-2.750	69,926-69,850	6.030-6.025	153,16-153,04	2.760-2.757	70,104-70,028	35.72	907,3
2522607	2.753-2.750	69,926-69,850	6.030-6.025	153,16-153,04	2.758-2.756	70,053-70,003	35.72	907,3

380 III A STEER

1528437	3.503-3.500	88,976-88,900	8.045-8.040	204,34-204,22	3.508-3.506	89,103-89,053	29.25	743,0
2522598	3.503-3.500	88,976-88,900	8.045-8.040	204,34-204,22	3.508-3.506	89,103-89,053	29.25	743,0
2536465	---	---	8.045-8.040	204,34-204,22	---	---	29.25	743,0

380 III A TILT

964577	2.753-2.750	69,926-69,850	6.030-6.025	153,16-153,04	---	---	10.875	276,2
1532052	2.753-2.750	69,926-69,850	6.030-6.025	153,16-153,04	2.760-2.757	70,104-70,028	10.875	276,2
2522120	2.753-2.750	69,926-69,850	6.030-6.025	153,16-153,04	2.758-2.756	70,053-70,003	10.875	276,2

380 III A PITCH

964583	2.253-2.250	57,226-57,150	5.280-5.275	134,11-133,99	---	---	17.562	743,0
1505457	2.253-2.250	57,226-57,150	5.280-5.275	134,11-133,99	2.260-2.257	57,404-57,328	17.562	743,0
2522411	2.253-2.250	57,226-57,150	5.280-5.275	134,11-133,99	2.258-2.256	57,353-57,303	17.562	743,0

380 III A LIFT

962697	2.753-2.750	69,926-69,850	6.030-6.025	153,16-153,04	---	---	35.14	892,6
1510225	2.753-2.750	69,926-69,850	6.030-6.025	153,16-153,04	---	---	35.12	892,0
2522115	2.753-2.750	69,926-69,850	6.030-6.025	153,16-153,04	2.758-2.756	70,053-70,003	35.14	892,6

380B STEER

1528437	3.503-3.500	88,976-88,900	8.045-8.040	204,34-204,22	3.508-3.506	89,103-89,053	29.25	743,0
2522598	3.503-3.500	88,976-88,900	8.045-8.040	204,34-204,22	3.508-3.506	89,103-89,053	29.25	743,0

380B TILT

964577	2.753-2.750	69,926-69,850	6.030-6.025	153,16-153,04	---	---	10.875	276,2
1532052	2.753-2.750	69,926-69,850	6.030-6.025	153,16-153,04	2.760-2.757	70,104-70,028	10.875	276,2
2522120	2.753-2.750	69,926-69,850	6.030-6.025	153,16-153,04	2.758-2.756	70,053-70,003	10.875	276,2

CLARK

ASSEMBLY SPECIFICATIONS

Cylinder Number	Piston Nut Torque			Piston Lock Bolt Torque (Threaded Pistons Only)			Cylinder Cap Bolt Torque			Retainer Ring Bolt Torque			Piston to Center of Rod Eye Dimension	
	lb•ft	N•m	kgf•m	lb•ft	N•m	kgf•m	lb•ft	N•m	kgf•m	lb•ft	N•m	kgf•m	in	mm

380B PITCH

964583	1500	2034	207,4	---	---	---	175-190	240-260	24,2-26,3	35-40	48-54	4,8-5,5	---	---
1505457	1500	2034	207,4	---	---	---	175-190	240-260	24,2-26,3	FINGER TIGHTEN			---	---
2522411	1500	2034	207,4	---	---	---	175-190	240-260	24,2-26,3	35-40	48-54	4,8-5,5	---	---

380B LIFT

962697	1500	2034	207,4	---	---	---	175-190	240-260	24,2-26,3	90-100	122-135	16,9-18,9	---	---
1510225	1500	2034	207,4	---	---	---	300-330	410-450	41,5-45,6	FINGER TIGHTEN			---	---
2522115	1500	2034	207,4	---	---	---	175-190	240-260	24,2-26,3	90-100	122-135	16,9-18,9	---	---

662 STEER

1904666	500	680	69,10	---	---	---	---	---	---	18-20	24-27	2,5-2,7	---	---
---------	-----	-----	-------	-----	-----	-----	-----	-----	-----	-------	-------	---------	-----	-----

662 BLADE

1904666	500	680	69,10	---	---	---	---	---	---	18-20	24-27	2,5-2,7	---	---
---------	-----	-----	-------	-----	-----	-----	-----	-----	-----	-------	-------	---------	-----	-----

664/664GR STEER

1904666	500	680	69,10	---	---	---	---	---	---	18-20	24-27	2,5-2,7	---	---
1904674	---	---	---	---	---	---	---	---	---	18-20	24-27	2,5-2,7	---	---
1906258	500	680	69,10	---	---	---	---	---	---	18-20	24-27	2,5-2,7	---	---
2526178	---	---	---	18-20	24-27	2,5-2,7	---	---	---	---	---	---	28,96	735,6

664/664GR BLADE

1904666	500	680	69,10	---	---	---	---	---	---	18-20	24-27	2,5-2,7	---	---
1904674	---	---	---	---	---	---	---	---	---	18-20	24-27	2,5-2,7	---	---
1906258	500	680	69,10	---	---	---	---	---	---	18-20	24-27	2,5-2,7	---	---
2526178	---	---	---	18-20	24-27	2,5-2,7	---	---	---	---	---	---	28,96	735,6

664/664GR GRAPPLE

1916233	---	---	---	---	---	---	---	---	---	---	---	---	---	---
1927276	---	---	---	---	---	---	---	---	---	18-20	24-27	2,5-2,7	---	---

664/664GR ARCH

1904666	500	680	69,10	---	---	---	---	---	---	18-20	24-27	2,5-2,7	---	---
1906258	500	680	69,10	---	---	---	---	---	---	18-20	24-27	2,5-2,7	---	---
2526178	---	---	---	18-20	24-27	2,5-2,7	---	---	---	---	---	---	28,96	735,6

665/665GR STEER

2526178	---	---	---	18-20	24-27	2,5-2,7	---	---	---	---	---	---	28,96	735,6
---------	-----	-----	-----	-------	-------	---------	-----	-----	-----	-----	-----	-----	-------	-------

665/665GR BLADE

2626178	---	---	---	18-20	24-27	2,5-2,7	---	---	---	---	---	---	28,96	735,6
---------	-----	-----	-----	-------	-------	---------	-----	-----	-----	-----	-----	-----	-------	-------

665/665GR GRAPPLE

2532851	---	---	---	---	---	---	---	---	---	18-20	24-27	2,5-2,7	23,00	584,5
---------	-----	-----	-----	-----	-----	-----	-----	-----	-----	-------	-------	---------	-------	-------

665/665GR ARCH

2526178	---	---	---	18-20	24-27	2,5-2,7	---	---	---	---	---	---	28,96	735,6
---------	-----	-----	-----	-------	-------	---------	-----	-----	-----	-----	-----	-----	-------	-------

CLARK

CYLINDER SPECIFICATIONS (ORIGINAL DIMENSIONS)

Cylinder Number	Rod Diameter		Tube Bore		Cap or Sleeve Bore		Stroke	
	in	mm	in	mm	in	mm	in	mm

380B PITCH

964583	2.253-2.250	57,226-57,150	5.280-5.275	134,11-133,99	---	---	17.562	446,1
1505457	2.253-2.250	57,226-57,150	5.280-5.275	134,11-133,99	2.260-2.257	57,404-57,328	17.562	446,1
2522411	2.253-2.250	57,226-57,150	5.280-5.275	134,11-133,99	2.258-2.256	57,353-57,303	17.562	446,1

380B LIFT

962697	2.753-2.750	69,926-69,850	6.030-6.025	153,16-153,04	---	---	35.14	892,6
1510225	2.753-2.750	69,926-69,850	6.030-6.025	153,16-153,04	---	---	35.12	892,0
2522115	2.753-2.750	69,926-69,850	6.030-6.025	153,16-153,04	2.758-2.756	70,053-70,003	35.12	892,0

662 STEER

1904666	1.750-1.748	44,400-44,300	---	---	---	---	17.00	431,8
---------	-------------	---------------	-----	-----	-----	-----	-------	-------

662 BLADE

1904666	1.750-1.748	44,400-44,300	---	---	---	---	17.00	431,8
---------	-------------	---------------	-----	-----	-----	-----	-------	-------

664/664GR STEER

1904666	1.750-1.748	44,400-44,300	---	---	---	---	17.00	431,8
1904674	1.747-1.746	44,37-44,35	---	---	---	---	17.00	431,8
1906258	1.747-1.746	44,37-44,35	---	---	---	---	17.00	431,8
2526178	2.000-1.997	50,800-50,724	4.030-4.025	102,36-102,24	2.007-2.005	50,977-50,927	21.65	549,9

664/664GR BLADE

1904666	1.750-1.748	44,400-44,300	---	---	---	---	17.00	451,8
1904674	1.747-1.746	44,37-44,35	---	---	---	---	17.00	451,8
1906258	1.747-1.746	44,37-44,35	---	---	---	---	17.00	431,8
2526178	2.000-1.997	50,800-50,724	4.030-4.025	102,36-102,24	2.007-2.005	50,977-50,927	21.65	548,9

664/664GR GRAPPLE

1916233	2.749-2.747	69,825-69,774	---	---	---	---	15.00	381,0
1927276	2.000-1.998	50,80-50,75	---	---	---	---	15.00	381,0

664/664GR ARCH

1904666	1.750-1.748	44,400-44,300	---	---	---	---	17.00	431,8
1906258	1.747-1.746	44,37-44,35	---	---	---	---	17.00	431,8
2526178	2.000-1.997	50,800-50,724	4.030-4.025	102,36-102,24	2.007-2.005	50,977-50,927	21.65	549,9

665/665GR STEER

2526178	2.000-1.997	50,800-50,724	4.030-4.025	102,36-102,24	2.007-2.005	50,977-50,927	21.65	549,9
---------	-------------	---------------	-------------	---------------	-------------	---------------	-------	-------

665/665GR BLADE

2526178	2.000-1.997	50,800-50,724	4.030-4.025	102,36-102,24	2.007-2.005	50,977-50,927	21.65	549,9
---------	-------------	---------------	-------------	---------------	-------------	---------------	-------	-------

665/665GR GRAPPLE

2532851	2.000-1.997	50,800-50,724	4.030-4.025	102,36-102,24	2.007-2.005	50,977-50,927	21.65	549,9
---------	-------------	---------------	-------------	---------------	-------------	---------------	-------	-------

665/665GR ARCH

2526178	2.000-1.997	50,800-50,724	4.030-4.025	102,36-102,24	2.007-2.005	50,977-50,927	21.65	549,9
---------	-------------	---------------	-------------	---------------	-------------	---------------	-------	-------

CLARK

ASSEMBLY SPECIFICATIONS

Cylinder Number	Piston Nut Torque			Piston Lock Bolt Torque (Threaded Pistons Only)			Cylinder Cap Bolt Torque			Retainer Ring Bolt Torque			Piston to Center of Rod Eye Dimension	
	lb•ft	N•m	kgf•m	lb•ft	N•m	kgf•m	lb•ft	N•m	kgf•m	lb•ft	N•m	kgf•m	in	mm

666/666GR STEER

1904666	500	680	69,10	---	---	---	---	---	---	18-20	24-27	2,5-2,7	---	---
1904674	---	---	---	---	---	---	---	---	---	18-20	24-27	2,5-2,7	---	---
1906258	500	680	69,10	---	---	---	---	---	---	18-20	24-27	2,5-2,7	---	---

666/666GR BLADE

1904666	500	680	69,10	---	---	---	---	---	---	18-20	24-27	2,5-2,7	---	---
1904674	---	---	---	---	---	---	---	---	---	18-20	24-27	2,5-2,7	---	---
1906258	500	680	69,10	---	---	---	---	---	---	18-20	24-27	2,5-2,7	---	---

666/666GR GRAPPLE

1916233	---	---	---	---	---	---	---	---	---	---	---	---	---	---
1927276	---	---	---	---	---	---	---	---	---	18-20	24-27	2,5-2,7	---	---

666/666GR ARCH

1904666	500	680	69,10	---	---	---	---	---	---	18-20	24-27	2,5-2,7	---	---
1906258	500	680	69,10	---	---	---	---	---	---	18-20	24-27	2,5-2,7	---	---

667/667GR STEER

1904666	500	680	69,10	---	---	---	---	---	---	18-20	24-27	2,5-2,7	---	---
1917220	---	---	---	---	---	---	---	---	---	18-20	24-27	2,5-2,7	---	---

667/667GR BLADE

1904666	500	680	69,10	---	---	---	---	---	---	18-20	24-27	2,5-2,7	---	---
1917220	---	---	---	---	---	---	---	---	---	18-20	24-27	2,5-2,7	---	---

667/667GR GRAPPLE

1916233	---	---	---	---	---	---	---	---	---	---	---	---	---	---
1919023	---	---	---	---	---	---	---	---	---	18-20	24-27	2,5-2,7	---	---
2526178	---	---	---	18-20	24-27	2,5-2,7	---	---	---	---	---	---	28,96	735,6

667/667GR ARCH

1904666	500	680	69,10	---	---	---	---	---	---	18-20	24-27	2,5-2,7	---	---
1917220	---	---	---	---	---	---	---	---	---	18-20	24-27	2,5-2,7	---	---
2526178	---	---	---	18-20	24-27	2,5-2,7	---	---	---	---	---	---	28,96	735,6

667/667GR BOOM

1906165	500	680	69,10	---	---	---	---	---	---	18-20	24-27	2,5-2,7	---	---
---------	-----	-----	-------	-----	-----	-----	-----	-----	-----	-------	-------	---------	-----	-----

668/668GR STEER

1903548	---	---	---	---	---	---	---	---	---	18-20	24-27	2,5-2,7	---	---
---------	-----	-----	-----	-----	-----	-----	-----	-----	-----	-------	-------	---------	-----	-----

668/668GR BLADE

1903548	---	---	---	---	---	---	---	---	---	18-20	24-27	2,5-2,7	---	---
---------	-----	-----	-----	-----	-----	-----	-----	-----	-----	-------	-------	---------	-----	-----

668/668GR TILT

2518802	---	---	---	20	27	2,8	---	---	---	4	5,4	,55	20,98	532,9
---------	-----	-----	-----	----	----	-----	-----	-----	-----	---	-----	-----	-------	-------

CLARK

CYLINDER SPECIFICATIONS (ORIGINAL DIMENSIONS)

Cylinder Number	Rod Diameter		Tube Bore		Cap or Sleeve Bore		Stroke	
	in	mm	in	mm	in	mm	in	mm

666/666GR STEER

1904666	1.750-1.748	44,400-44,300	---	---	---	---	17.00	431,8
1904674	1.747-1.746	44,37-44,35	---	---	---	---	17.00	431,8
1906258	1.747-1.746	44,37-44,35	---	---	---	---	17.00	431,8

666/666GR BLADE

1904666	1.750-1.748	44,400-44,300	---	---	---	---	17.00	431,8
1904674	1.747-1.746	44,37-44,35	---	---	---	---	17.00	431,8
1906258	1.747-1.746	44,37-44,35	---	---	---	---	17.00	431,8

666/666GR GRAPPLE

1916233	2.749-2.747	69,825-69,774	---	---	---	---	15.00	381,0
1927276	2.000-1.998	50,80-50,75	---	---	---	---	15.00	381,0

666/666GR ARCH

1904666	1.750-1.748	44,400-44,300	---	---	---	---	17.00	431,8
1906258	1.747-1.746	44,37-44,35	---	---	---	---	17.00	431,8

667/667 GR STEER

1904666	1.750-1.748	44,400-44,300	---	---	---	---	17.00	431,8
1917220	1.750-1.748	44,400-44,300	---	---	---	---	19.75	501,7

667/667GR BLADE

1904666	1.750-1.748	44,400-44,300	---	---	---	---	17.00	431,8
1917220	1.750-1.748	44,400-44,300	---	---	---	---	19.75	501,7

667/667GR GRAPPLE

1916233	2.749-2.747	69,825-69,774	---	---	---	---	15.00	381,0
1919023	1.750-1.748	44,400-44,300	---	---	---	---	19.75	501,7
2526178	2.000-1.997	50,800-50,724	4.030-4.025	102,36-102,24	2.007-2.005	50,977-50,927	21.65	549,9

667/667GR ARCH

1904666	1.750-1.748	44,400-44,300	---	---	---	---	17.00	431,8
1917220	1.750-1.748	44,400-44,300	---	---	---	---	19.75	501,7
2526178	2.000-1.997	50,800-50,724	4.030-4.025	102,36-102,24	2.007-2.005	50,977-50,927	21.65	549,9

667/667GR BOOM

1906165	1.750-1.748	44,400-44,300	---	---	---	---	17.00	431,8
---------	-------------	---------------	-----	-----	-----	-----	-------	-------

668/668GR STEER

1903548	2.000-1.998	50,80-50,75	---	---	---	---	20.50	520,7
---------	-------------	-------------	-----	-----	-----	-----	-------	-------

668/668GR BLADE

1903548	2.000-1.998	50,80-50,75	---	---	---	---	20.50	520,7
---------	-------------	-------------	-----	-----	-----	-----	-------	-------

668/668GR TILT

2518802	1.753-1.750	44,526-44,450	3.530-3.525	89,66-89,54	1.757-1.755	44,627-44,577	16.00	406,4
---------	-------------	---------------	-------------	-------------	-------------	---------------	-------	-------

ADDITIONAL CYLINDERS

NOTE: The additional cylinders will not have the specifications listed in this supplement. The specifications may be found by using the cylinder number in the last column of this chart.

Model	Application	Cylinder Number	See This Cylinder Number For The Specifications
55B	Steering	964667	2532705
75B	Boom	964783	2527513
75B	Boom	964784	2527549
75B	Steering	964667	2532705
75C	Boom	964783	2536739
75C	Boom	964784	2536734
75C	Bucket	964791	2529648
75C	Bucket	964791	2529648
75C	Steering	964792	2529205
125B	Steering	964671	2532427
125C	Boom	964793	2528983
125C	Boom	964794	2528982
125C	Bucket	964795	2525298
125C	Bucket	964796	2532213
125C	Bucket	964797	2525743
175B	Bucket	964798	2524276
175B	Steering	964586	2532353
175C	Boom	964799	2524467
175C	Bucket	964798	2524276
175C	Steering	964801	2528848
275B	Steering	962700	2532606
275C	Boom	964802	2525863
275C	Bucket	964803	2529399
275C	Steering	964804	2529566
475B	Steering	964592	2514101
475C	Boom	964805	2528161
475C	Bucket	964806	2524053
475C	Steering	964807	2527900
280 IIIA	Steering	964584	2522932
280B	Steering	964663	2528419
380 IIIA	Steering	964593	2522598
380B	Steering	964593	2522598

CLARK

NOTES