

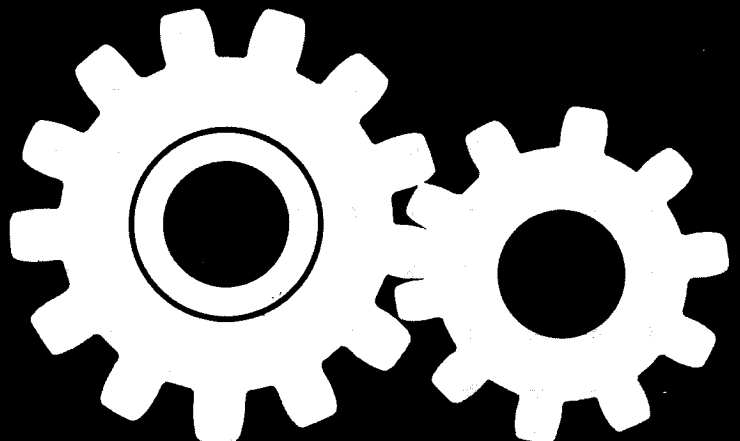
**3000 SERIES
TRANSMISSION**

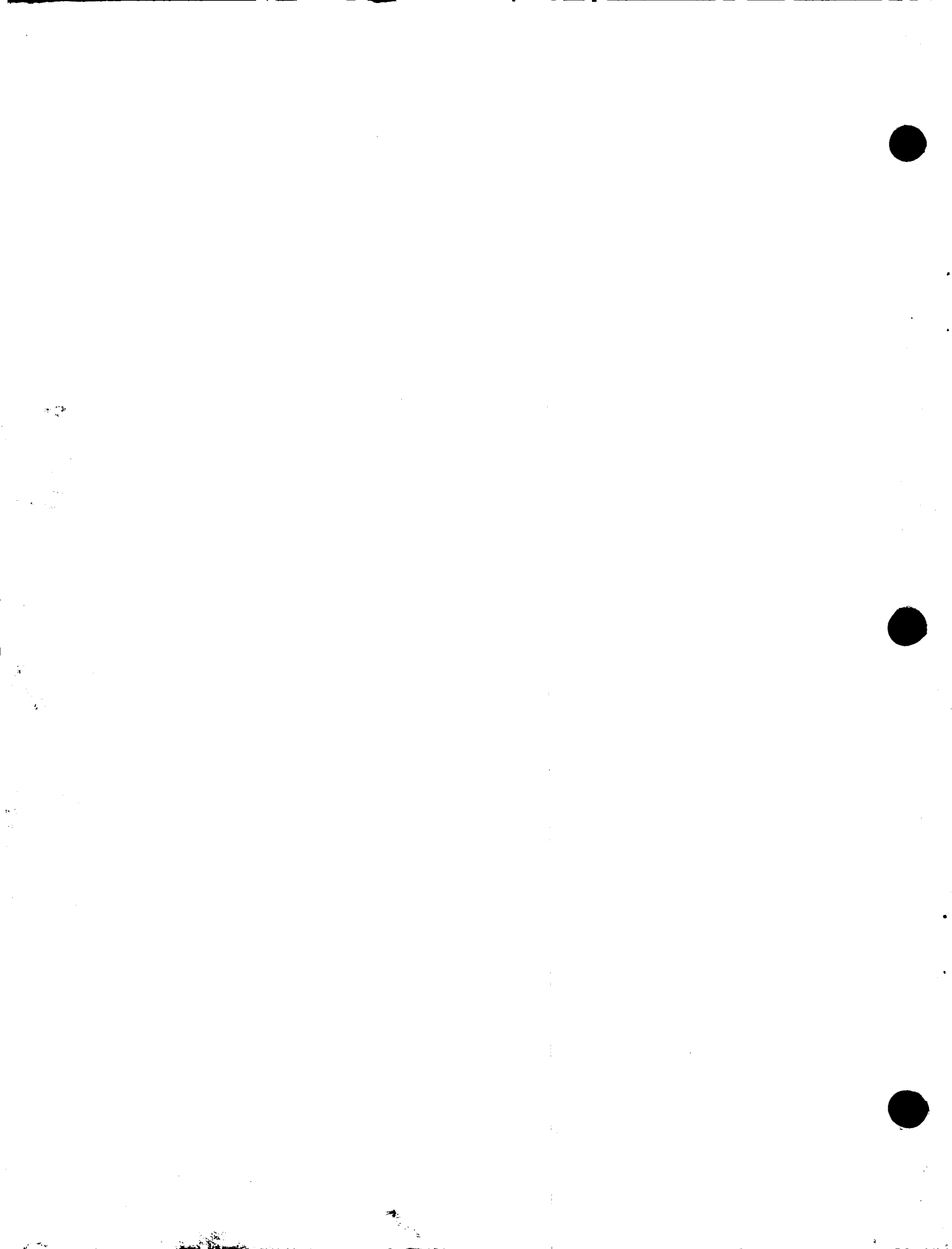
SHOP

MANUAL

CLARK

Michigan Company





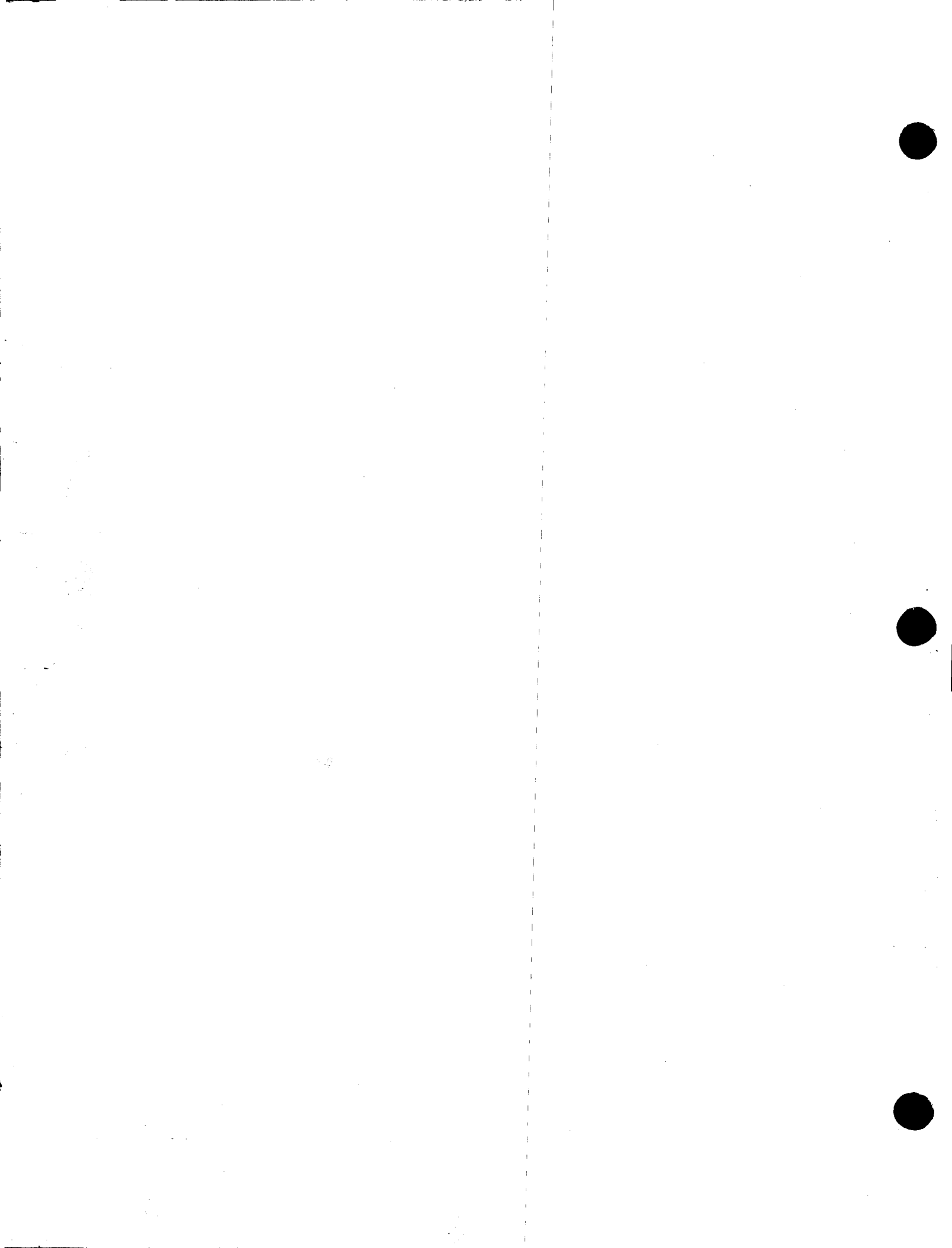
CLARK

**3000 SERIES
TRANSMISSION**

SHOP

MANUAL

**PUBLICATION
NO. 2256**



FOREWORD



This manual has been prepared to provide the customer and the maintenance personnel with information and instructions on the maintenance and repair of the **CLARK** Power Shift Transmission.

Extreme care has been exercised in the design, selection of materials and manufacturing of these units. The slight outlay in personal attention and cost required to provide regular and proper lubrication, inspection at stated intervals, and such adjustments as may be indicated will be reimbursed many times in low cost operation and trouble free service.

In order to become familiar with the various parts of the transmission, its principle of operation, trouble shooting and adjustments, it is urged that the mechanic study the instructions in this manual carefully and use it as a reference when performing maintenance and repair operations.

Whenever repair or replacement of component parts is required, only Clark-approved parts as listed in the applicable parts manual should be used. Use of "will-fit" or non-approved parts may endanger proper operation and performance of the equipment. The Clark Equipment Company does not warrant repair or replacement parts, nor failures resulting from the use thereof, which are not supplied by or approved by the Clark Equipment Company. **IMPORTANT: Always furnish the Distributor with the transmission serial and model number when ordering parts.**

N O T E S



TABLE OF CONTENTS

HOW THE UNITS OPERATE	4
SHAFT AND CLUTCH IDENTIFICATION	6
SECTIONAL VIEWS AND PARTS IDENTIFICATION	
a) Front and Rear Views, Shaft Identification	6
b) Transmission Case and Internal Tubing	7
c) Control Cover Assembly	8
d) Output Shaft and Disconnect Assembly Group—"O"	10
e) Idler Shaft Group—"I"	12
f) Input Shaft and Forward Group—"F"	12
g) Reverse Drive Shaft Group—"R"	12
h) Second and Fourth Drive Shaft Group—"A"	14
i) First and Third Drive Shaft Group—"B"	14
l) External Oil Flow—Converter and Transmission	16
DISASSEMBLY OF THE TRANSMISSION	17
REASSEMBLY OF TRANSMISSION	29
SERVICING MACHINE AFTER TRANSMISSION OVERHAUL	45
SPECIFICATION AND SERVICE DATA	46
LUBRICATION	46
TROUBLE SHOOTING GUIDE	47
PRESSURE AND OIL FLOW CHECK SPECIFICATIONS	47
TABLE OF TORQUE LIMITS	47
PRESSURE AND OIL FLOW CHECK PROCEDURE	48

NOTE: Metric Dimensions Shown in Brackets [].

The transmission portion of the power train enacts an important role in delivering engine power to the driving wheels. In order to properly maintain and service these units it is important to first understand their function and how they operate.

The transmission and torque converter function together and operate through a common hydraulic system. To obtain maximum serviceability they have been designed and built as separate units. It is necessary, however, to consider both units in the study of their function and operation.

To supplement the text below, and for references use therewith, the following illustrations are provided:

- | | |
|----------------------------------------------------|--------------------------------------------------------|
| Fig. A — Front and Rear View, Shaft Identification | Fig. F — Input and Forward Drive Shaft Group—"F" |
| Fig. B — Transmission Case and Internal Tubing | Fig. G — Reverse Drive Shaft Group — "R" |
| Fig. C — Control Cover Assembly | Fig. H — 2nd and 4th Drive Shaft Group — "A" |
| Fig. D — Output Shaft Group — "O" | Fig. I — 1st and 3rd Drive Shaft Group — "B" |
| Fig. E — Idler Shaft Group — "I" | Fig. J — External Oil Flow—Converter and Transmission. |

HOW THE UNITS OPERATE —

With the engine running, the converter charging pump draws oil from the transmission sump and directs it through oil filters to the regulating valve located on top of the transmission. From the regulating valve it is then directed through the control cover on the transmission to the converter and to the transmission clutches.

The pressure regulating valve mounted on the top of the transmission remains closed until required pressure is delivered to the transmission for actuating the direction and speed clutches. This regulator valve consists of a hardened valve spool operating in a closely fitted bore. The valve spool is backed up by a spring to hold the valve spool against its seat until the oil pressure builds up to the specified pressure. The valve spool then moves toward the spring until a port is exposed along the side of the bore. The oil can then flow through this port into a distributor which directs the oil into the converter inlet port.

After entering the converter, the oil is directed through the stator support to the converter cavity and exits between the turbine shaft and converter support. The oil then passes through an oil distributor which directs the oil out of the converter by way of a down stream regulator valve and then to the oil cooler. After leaving the cooler the oil is directed through a hose to the lubricating oil inlet on the transmission, then through a series of tubes to the transmission, bearings, and clutches. The oil then returns to the transmission sump.

A safety valve is built in the transmission control cover and will open to bypass oil only if an excessive pressure is built up due to a blocked passage.

The rear compartment of the converter unit also houses the converter output shaft. A flexible hose provides an overflow to the transmission sump.

The three members of the torque converter are composed of a series of blades. The blades are curved in such a manner as to force the oil to circulate from the impeller to the turbine, through the reaction member again into the impeller. This circulation causes the turbine to turn in the same direction as the impeller. Oil enters the inner side of the impeller and exits from the outer side into the outer side of the turbine. It then exits from the inner side of the turbine and after passing through the reaction member, again enters the inner side of the impeller.

Converter stall is achieved whenever the turbine and output shaft are stationary and the engine is operating at full power or wide open throttle. **CAUTION:** Do not maintain "Stall" for more than 30 seconds at a time. Excessive heat will be generated and may cause converter or transmission seal damage.

In converters equipped with Lock-up clutches, a hydraulic clutch, similar to the transmission clutches is used to "lock" the engine mechanically to the output shaft. This is accomplished by hydraulic pressure actuating the lock-up clutch which in turn locks the impeller cover to the turbine hub. During lock-up the converter turns at 1 to 1 speed ratio.

The down stream regulator valve on the converter consists of a valve body and regulator spool. The spool is backed up by a spring to hold the valve until converter oil pressure builds up to specified pressure. The valve is used to maintain a given converter pressure to insure proper performance under all conditions.

The control valve assembly on the transmission consists of a valve body with selector valve spools connected to the steering column by exterior linkage. A detent ball and spring in the selector spool provides four positions, one position for each speed range. A detent ball and spring in the direction spool provides three positions, one each for forward, neutral, and reverse.

On certain models, this valve also contains a shut-off valve spool operated by an air or hydraulic cylinder located on the control cover. This valve is connected to the brake system by a hose line. When the wheel brakes are applied, air or hydraulic fluid enters the valve and overcomes a spring force. This forces the spool to shift over and block pressure from entering the directional clutches. In this manner a "neutral" is established without moving the control levers.

With the engine running and the directional control lever in neutral position, oil pressure is blocked at the control valve, and the transmission is in neutral. Movement of the forward and reverse spool will direct oil, under pressure, to either the forward or reverse direction clutch as desired, and the opposite one is open to relieve pressure.

The direction or speed clutch assembly consists of a drum with internal gear teeth and a bore to receive a hydraulically actuated piston. A piston is inserted into the bore of the drum. The piston is "oil tight" by the use of sealing rings. A friction disc with internal teeth is inserted into the drum and rests against the piston. Next, a disc with splines at the outer diameter is inserted. Discs are alternated until the required total is achieved. After inserting the last disc, a series of springs and pins are assembled in such a manner that these springs rest on teeth of the piston. A heavy back-up plate is then inserted and secured by a snap ring. A hub with I.D. and O.D. splines is inserted into the splines of discs with teeth on the inner diameter and a splined shaft extending through the clutch support. This hub is retained by a snap ring. The discs and inner shaft are free to increase in speed or rotated in the opposite direction as long as no pressure is present in the direction or speed clutch.

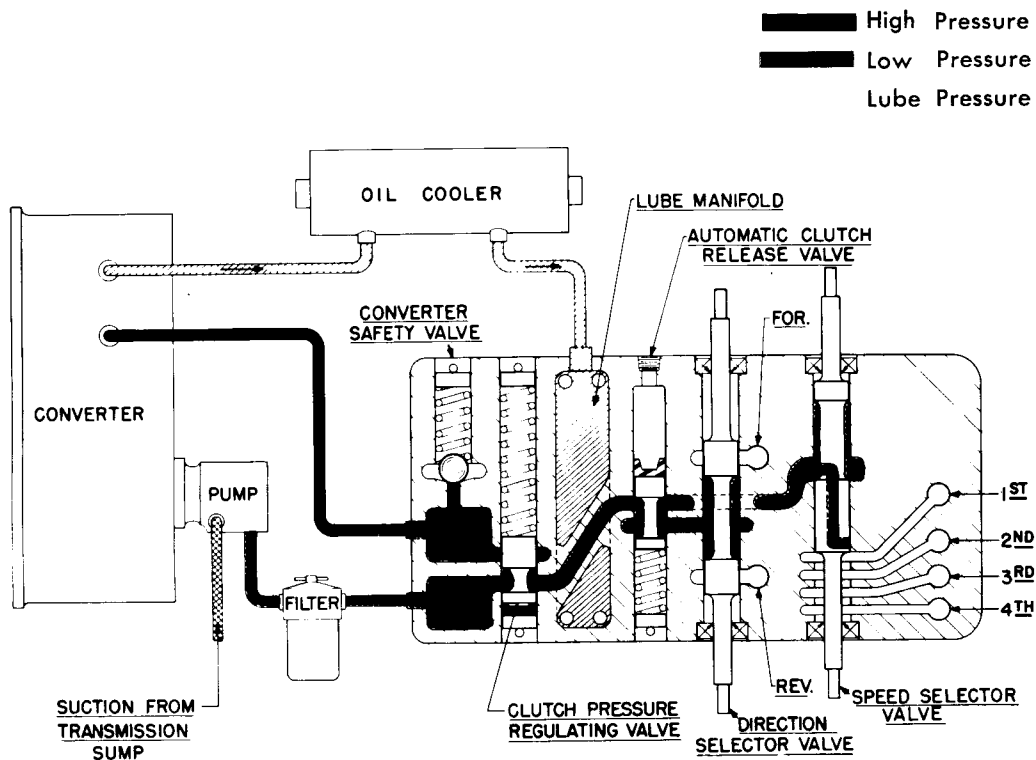
To engage the clutch, as previously stated, the control valve is placed in the desired position. This allows oil under pressure to flow from the control cover valve, through a tube in the transmission case, to a chosen clutch. Once into the drum, oil is directed through a drilled hole into the rear side of the piston bore. Pressure of the oil forces the piston and discs over against the heavy back-up plate. The discs, with teeth on the outer diameter, clamping against discs, with teeth on inner diameter, enables the clutch drum and drive shaft to be locked together and allows them to turn as a unit.

There are bleed balls in the clutch drums which allow quick escape for oil when the pressure to the piston is released.

The transmission gear train consists of six shafts: (1) Input Shaft, (2) Reverse Shaft, (3) Idler Shaft, (4) First and Third Shaft, (5) Second and Fourth Shaft, (6) Output Shaft.

A screen mounted in a frame is positioned on the bottom of the transmission case, to screen out any foreign material. This screen is covered by the sump pan. This pan is provided with magnets to catch any metallic particles.

Some transmissions may have an axle declutching unit as optional equipment, this unit consists of a split output shaft with a sliding splined sleeve to engage or disengage the axle. This is accomplished by manually shifting a lever in the operator's compartment which is mechanically connected to the shift fork on the clutching unit sliding sleeve. This unit, of course, is only used on the four wheel drive machine. On the front drive only or the rear wheel drive only, the output shaft is a one piece type and an output flange assembled only on the required end.



TRANSMISSION CONTROL COVER INTERNAL OILFLOW

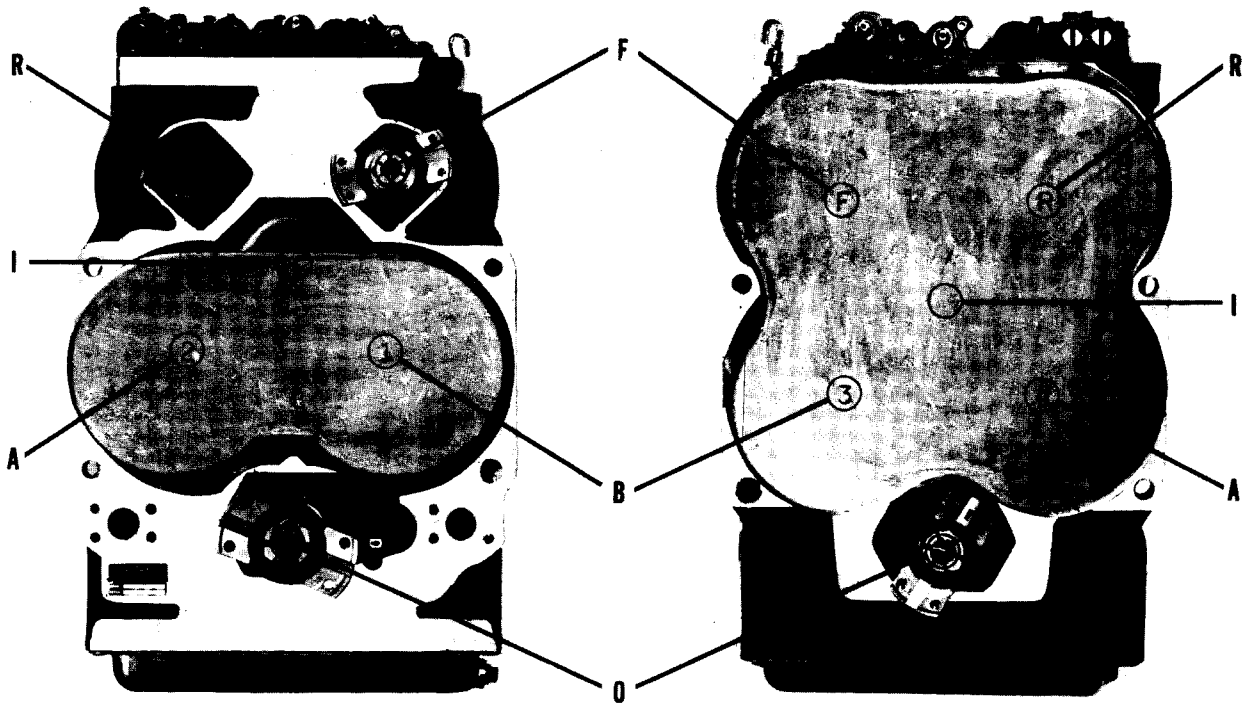


FIG. A — TRANSMISSION ASSEMBLY SHAFT IDENTIFICATION

For purpose of identification, illustration above indicates by alphabetical designation the individual shaft group location in transmission. Code to alphabetical designation is given below. Alphabetical designation also appears in heading of each shaft group covered in parts listings herein.

A—Second & Fourth Drive Shaft Group

B—First & Third Drive Shaft Group

F—Input Drive Shaft & Forward Clutch Group

I—Idler Shaft Group

O—Output Shaft & Disconnect Assembly Group

R—Reverse Drive Shaft Group

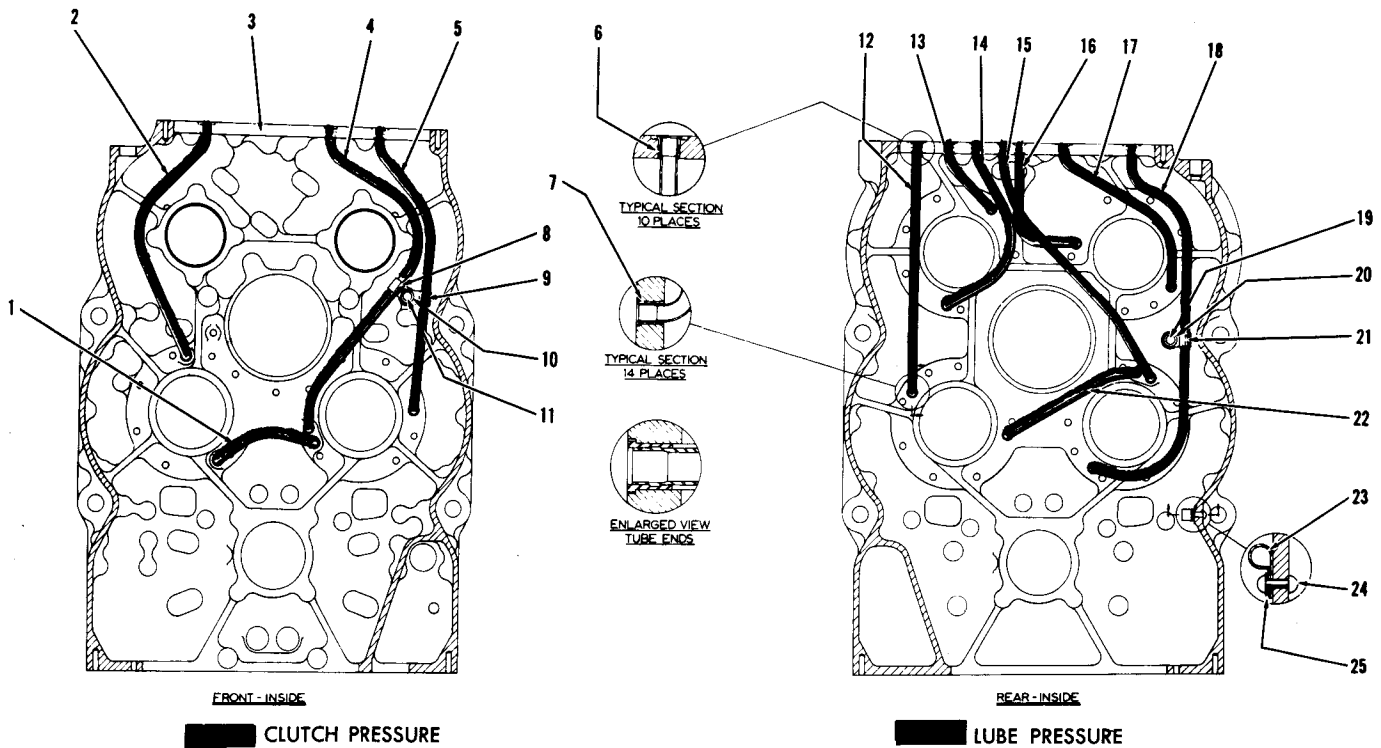
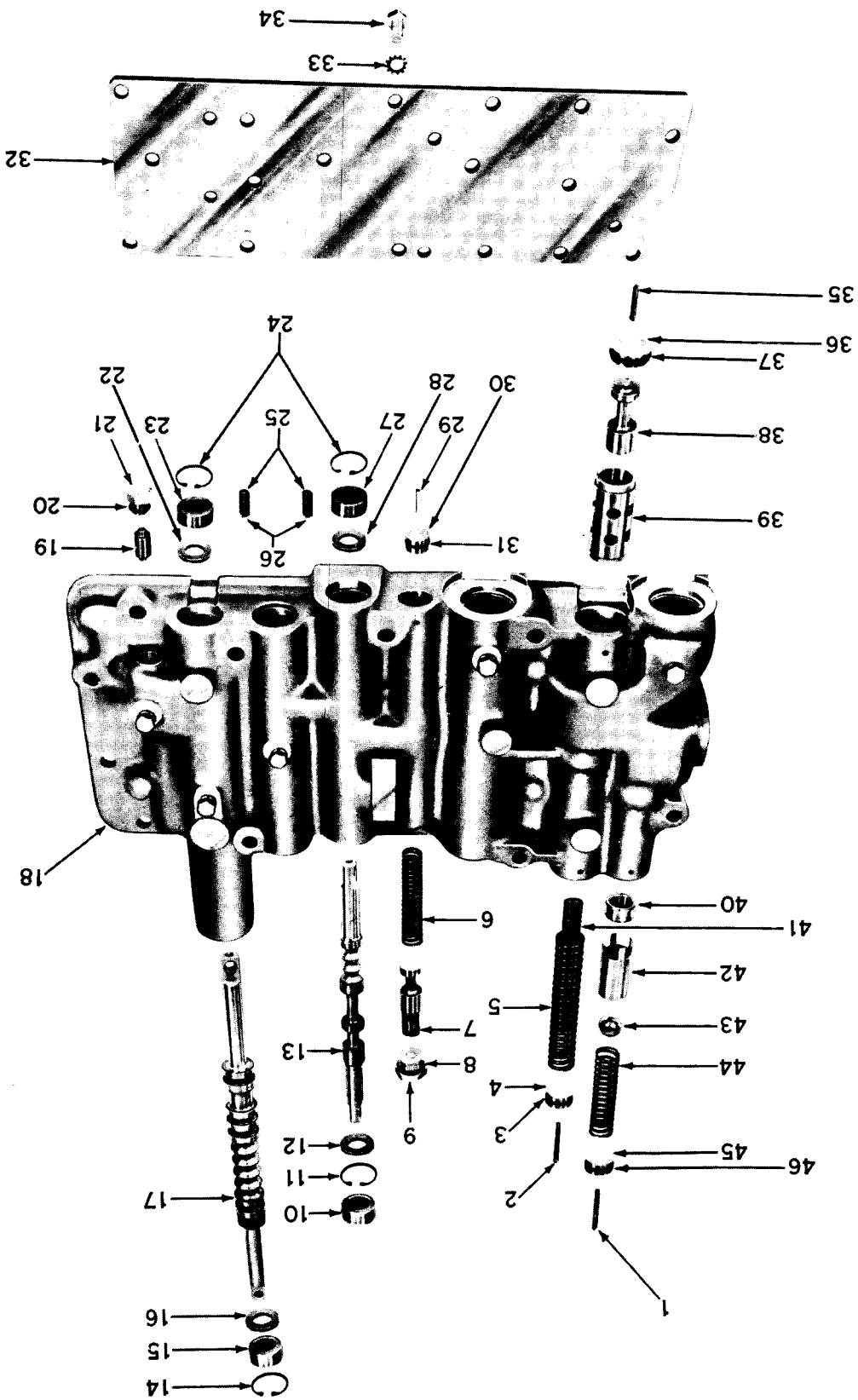


FIG. B — 3000 SERIES CASE ASSEMBLY

ITEM	DESCRIPTION	QTY.	ITEM	DESCRIPTION	QTY.
1	Lube Crossover Tube	1	14	Reverse Lube Tube	1
2	1st Clutch Pressure Tube	1	15	3rd Lube	1
3	Transmission Case	1	16	Input Lube Tube	1
4	2nd Clutch Lube Tube	1	17	Input Clutch Pressure Tube	1
5	2nd Clutch Pressure Tube	1	18	3rd Clutch Pressure Tube	1
6	Tube Sleeve	10	19	Tube Clip Rivet	1
7	Tube Sleeve	14	20	Tube Clip Washer	1
8	Tube Clip	1	21	Tube Clip	1
9	Tube Clip	1	22	Lube Crossover Tube	1
10	Tube Clip Washer	1	23	Dipstick Tube Clip	1
11	Tube Clip Rivet	1	24	Dipstick Tube Clip Rivet	1
12	4th Clutch Pressure Tube	1	25	Dipstick Tube Clip Washer	1
13	Reverse Clutch Pressure Tube	1			

3420



CLARK

CLARK

FIG. C — CONTROL COVER GROUP

ITEM	DESCRIPTION	QTY.	ITEM	DESCRIPTION	QTY.
1	Spring Stop Roll Pin.....	1	24	Valve Stop Snap Ring.....	1
2	Spring Stop Roll Pin.....	1	25	Poppet Spring.....	2
3	Spring Stop "O" Ring.....	1	26	Poppet Ball.....	2
4	Spring Stop.....	1	27	Valve Oil Seal.....	1
5	Regulator Valve Spring (Outer).....	1	28	Valve Stop Washer.....	1
6	Shut-off Valve Spool Spring.....	1	29	Spring Stop Roll Pin.....	1
7	Shut-off Valve Spool.....	1	30	Spring Stop.....	1
8	Shut-off Valve Hole Plug "O" Ring.....	1	31	Spring Stop "O" Ring.....	1
9	Shut-off Valve Hole Plug.....	1	32	Control Cover Plate.....	1
10	Valve Oil Seal.....	1	33	Control Cover Plate Screw Lockwasher 17	
11	Valve Stop Snap Ring.....	1	34	Control Cover Plate Screw.....	17
12	Valve Stop Washer.....	1	35	Spring Stop Roll Pin.....	1
13	Forward and Reverse Selector Valve.....	1	36	Valve Stop.....	1
14	Valve Stop Snap Ring.....	1	37	Valve Stop "O" Ring.....	1
15	Valve Oil Seal.....	1	38	Regulator Valve Spool.....	1
16	Valve Stop Washer.....	1	39	Regulator Valve Spool Sleeve.....	1
17	Speed Selector Valve Assembly.....	1	40	Safety Valve Seat.....	1
18	Control Cover.....	1	41	Regulator Valve Spring (Inner).....	1
19	Shuffle Valve.....	1	42	Safety Valve Spacer.....	1
20	Shuttle Valve "O" Ring.....	1	43	Safety Valve Ball.....	1
21	Shuttle Valve Plug.....	1	44	Safety Valve Spring.....	1
22	Valve Stop Washer.....	1	45	Spring Stop.....	1
23	Valve Oil Seal.....	1	46	Spring Stop "O" Ring.....	1

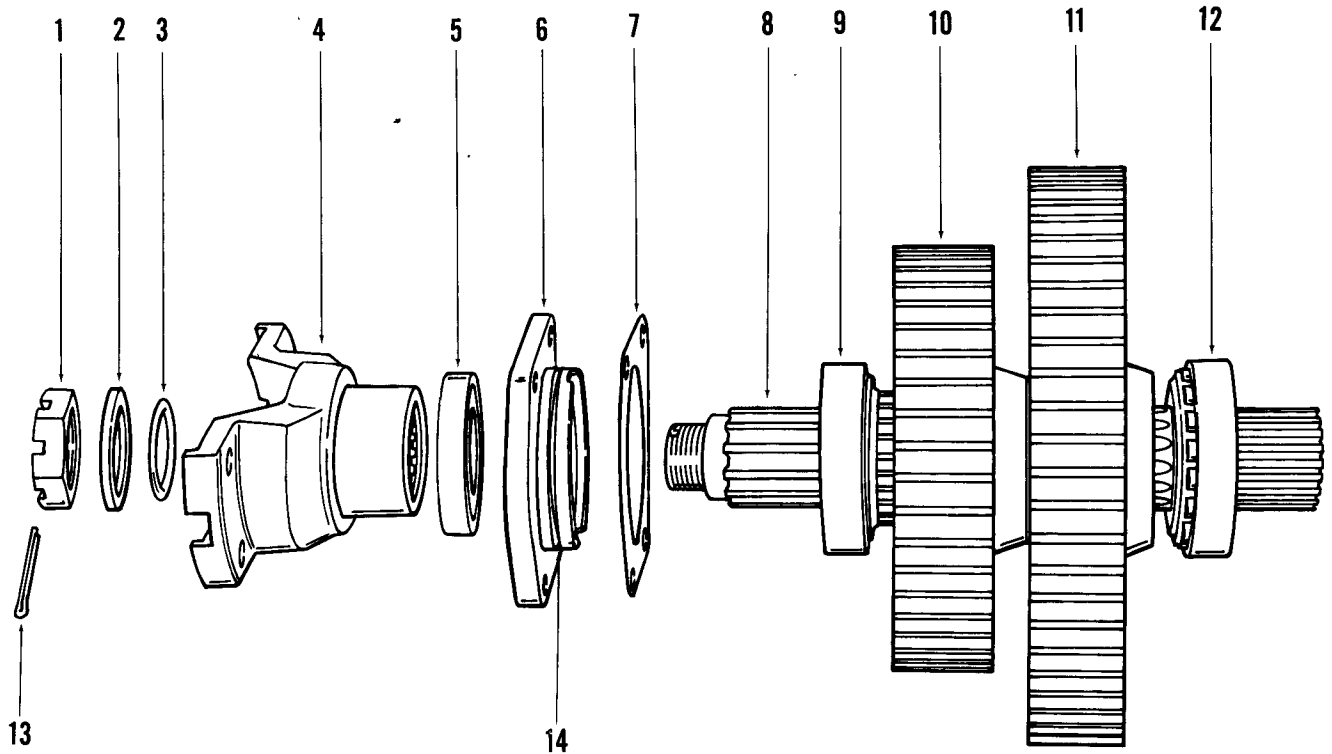


FIG. D OUTPUT SHAFT GROUP "O"

ITEM	DESCRIPTION	QTY.	ITEM	DESCRIPTION	QTY.
1	Flange Nut	1	8	Output Shaft.....	1
2	Flange Nut Washer.....	1	9	Output Shaft Taper Bearing.....	1
3	Flange Nut "O" Ring.....	1	10	Output Shaft Gear.....	1
4	Companion Flange.....	1	11	Output Shaft Gear.....	1
5	Oil Seal.....	1	12	Output Shaft Taper Bearing.....	1
6	Bearing Cap.....	1	13	Flange Nut Cotter.....	1
7	Bearing Cap Shim.....	1	14	Bearing Cap "O" Ring	1

CLARK

CLARK

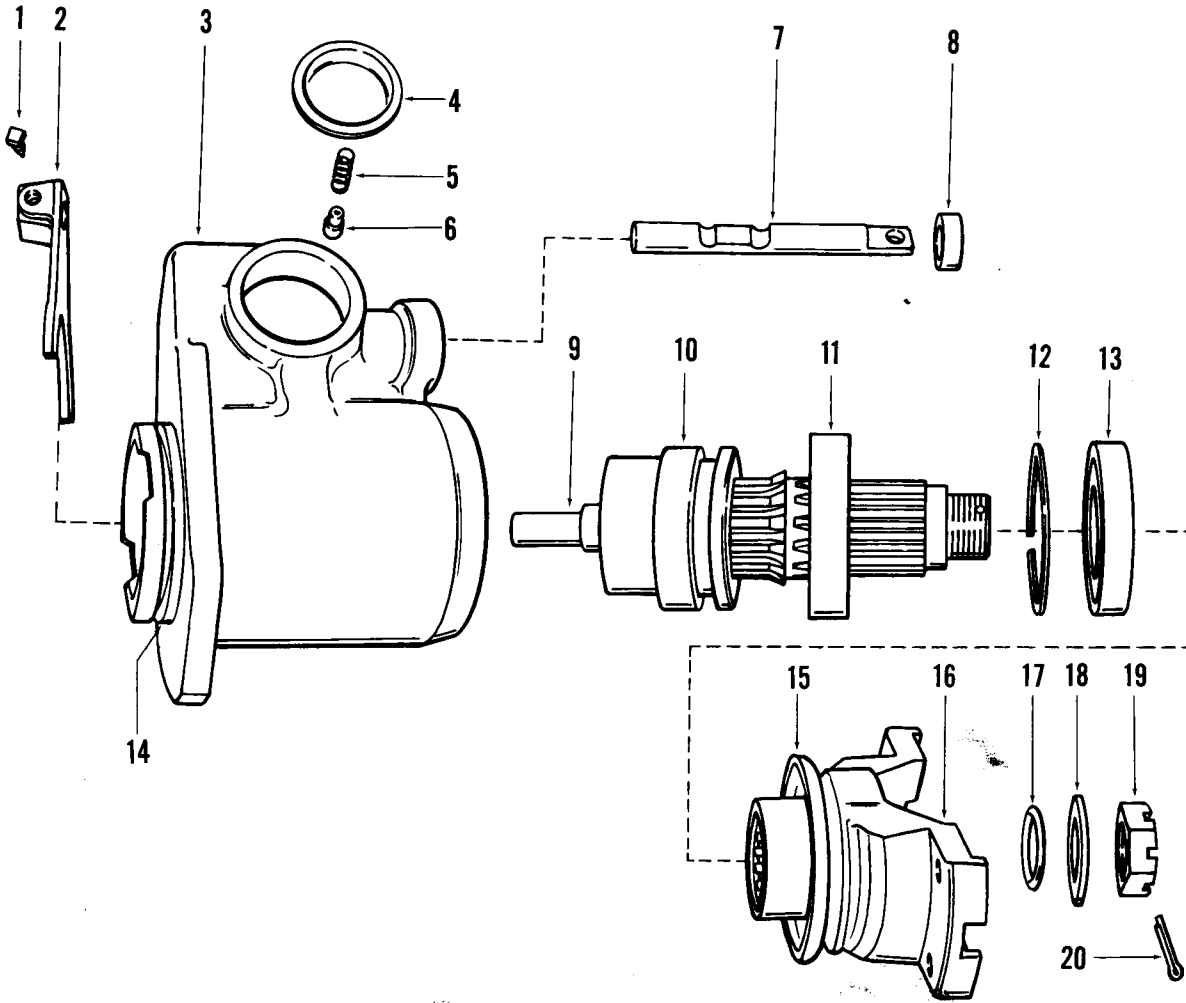


FIG. D DISCONNECT ASSEMBLY "O"

ITEM	DESCRIPTION	QTY.	ITEM	DESCRIPTION	QTY.
1	Lock Screw	1	11	Bearing	1
2	Shift Fork	1	12	Bearing Snap Ring	1
3	Disconnect Housing	1	13	Oil Seal	1
4	Housing Plug	1	14	Housing "O" Ring	1
5	Detent Spring	1	15	Companion Flange Deflector	1
6	Detent Ball	1	16	Companion Flange	1
7	Shift Rail	1	17	Flange "O" Ring	1
8	Oil Seal	1	18	Washer	1
9	Output Shaft	1	19	Nut	1
10	Shift Hub	1	20	Cotter Pin	1

CLARK

CLARK

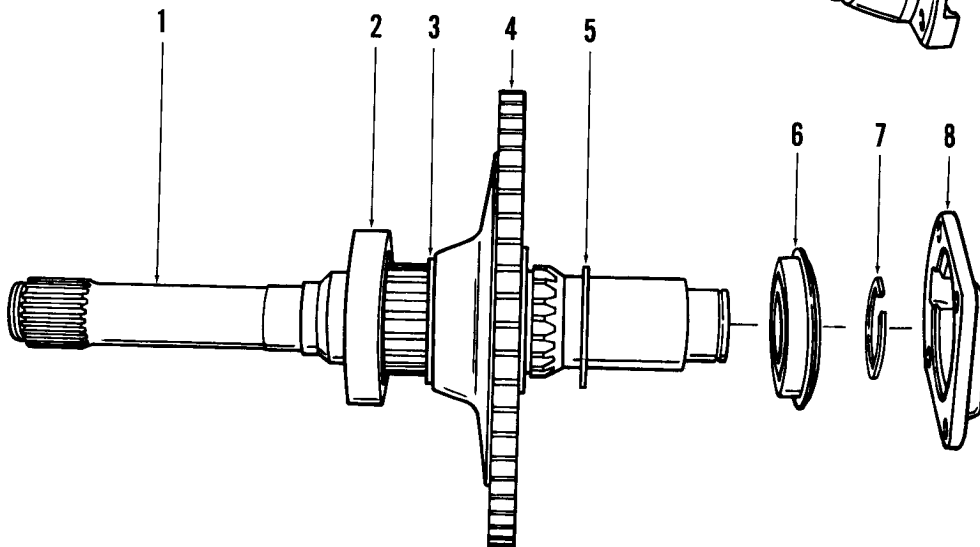
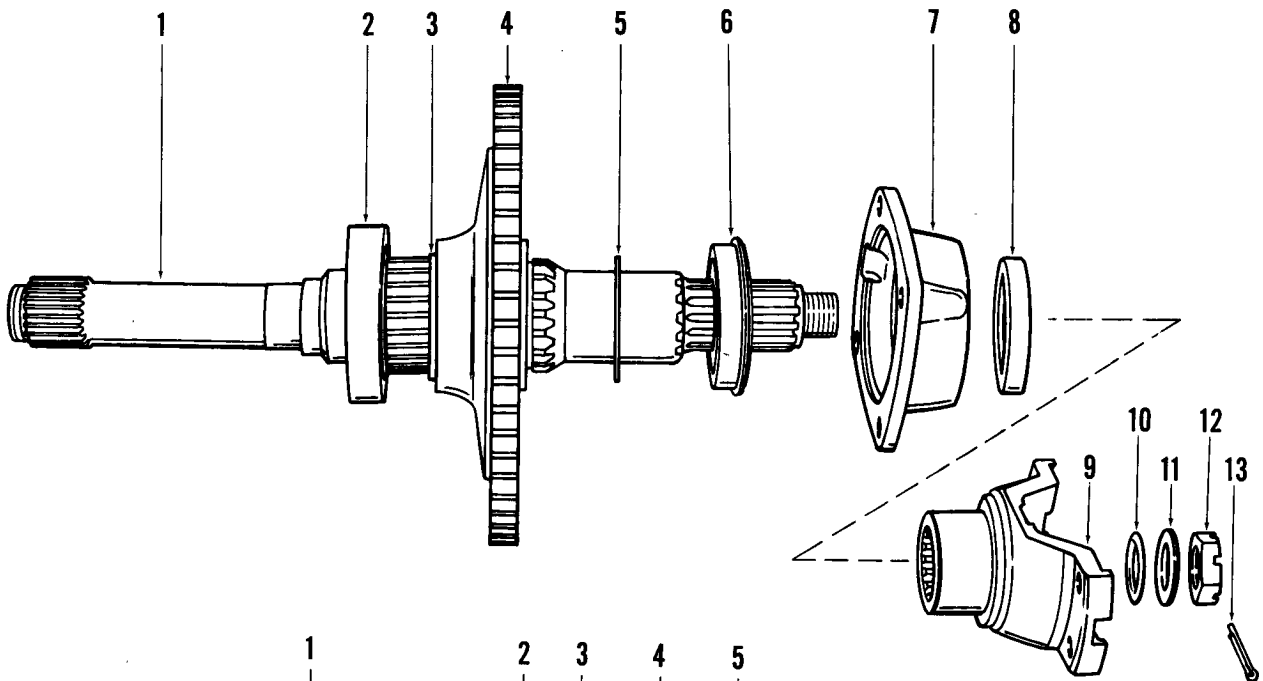
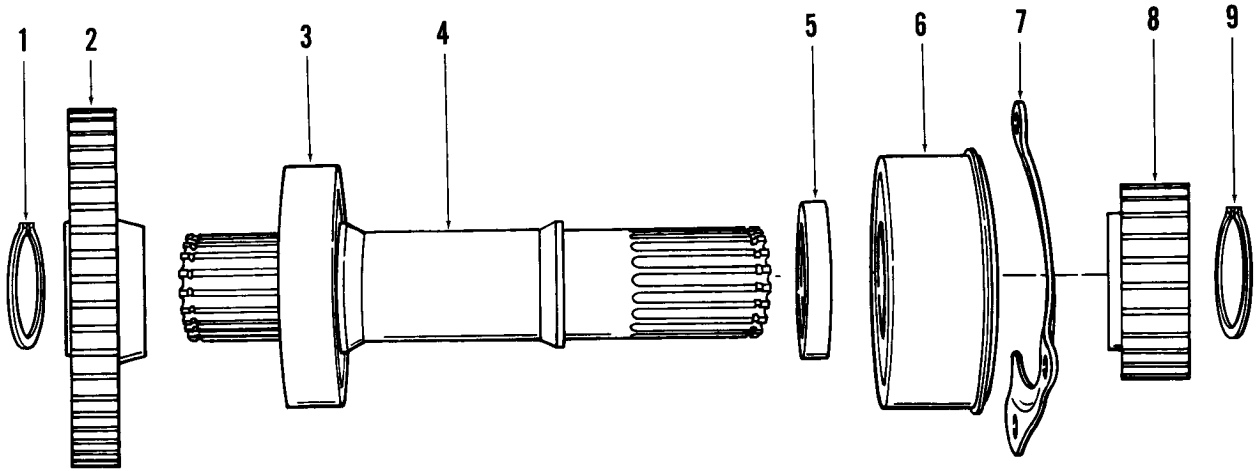


FIG. E IDLER SHAFT GROUP "I"

ITEM	DESCRIPTION	QTY.	ITEM	DESCRIPTION	QTY.
1	Gear Snap Ring.....	1	6	Front Bearing.....	1
2	Idler Gear.....	1	7	Bearing Retainer.....	1
3	Rear Bearing.....	1	8	Idler Gear.....	1
4	Idler Shaft.....	1	9	Gear Snap Ring.....	1
5	Bearing Spacer.....	1			

FIG. F INPUT SHAFT GROUP "F"

ITEM	DESCRIPTION	QTY.	ITEM	DESCRIPTION	QTY.
1	Input Shaft.....	1	8	Bearing Retainer Oil Seal.....	1
2	Rear Bearing.....	1	9	Companion Flange.....	1
3	Gear Locating Ring.....	1	10	Flange Nut "O" Ring.....	1
4	Input Gear.....	1	11	Flange Nut Washer.....	1
5	Gear Retainer Ring.....	1	12	Flange Nut.....	1
6	Front Bearing.....	1	13	Flange Nut Cotter.....	1
7	Bearing Retainer.....	1			

FIG. G REVERSE SHAFT GROUP "R"

ITEM	DESCRIPTION	QTY.	ITEM	DESCRIPTION	QTY.
1	Reverse Shaft.....	1	5	Gear Retainer Ring.....	1
2	Rear Bearing.....	1	6	Front Bearing.....	1
3	Gear Locating Ring.....	1	7	Bearing Retainer Ring.....	1
4	Reverse Gear.....	1	8	Bearing Cap.....	1

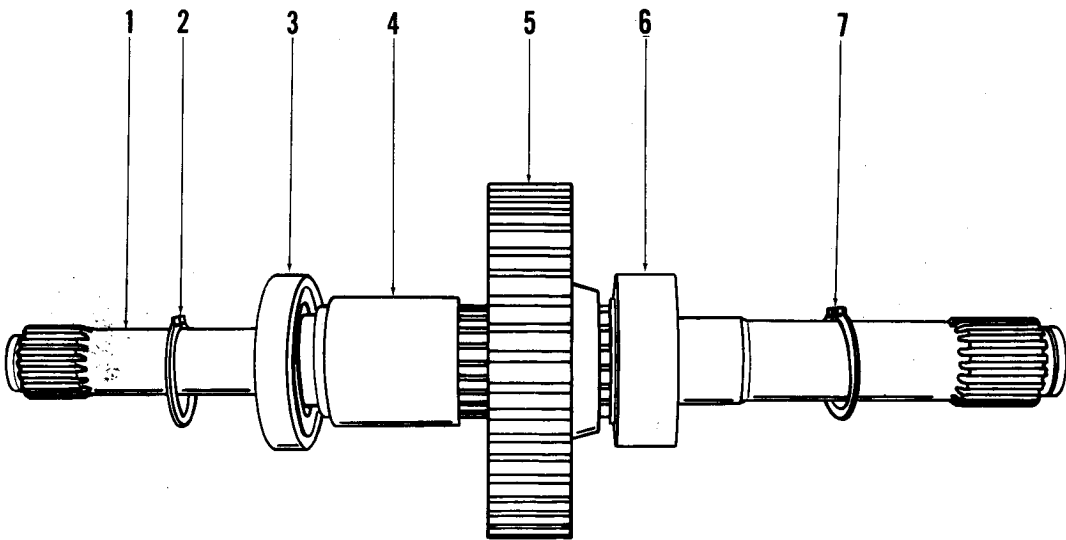
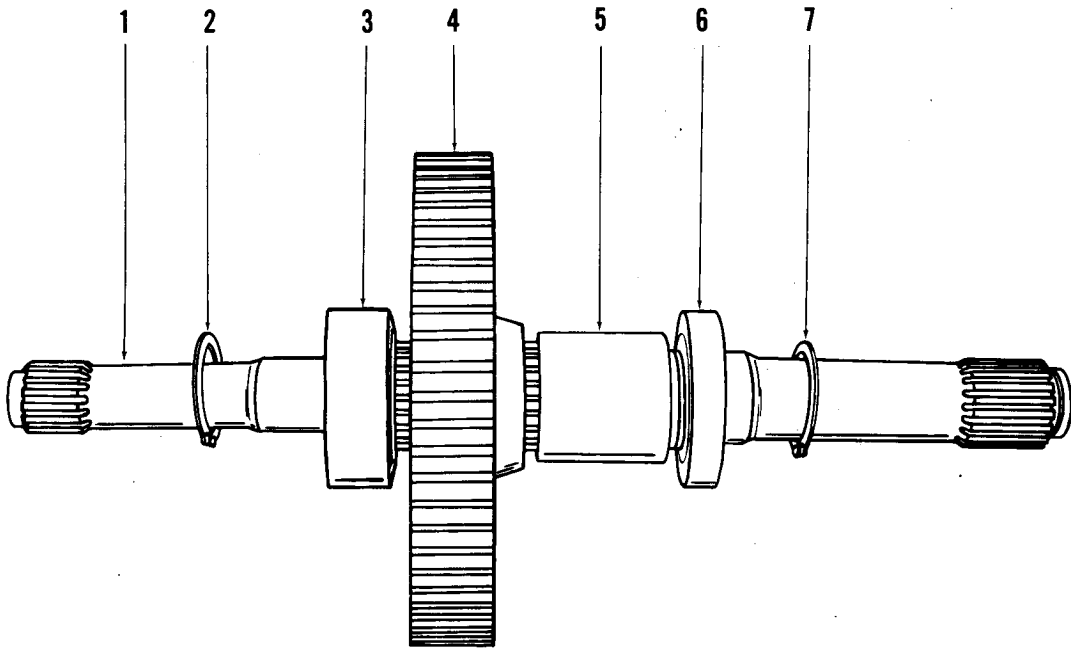


FIG. H 2nd and 4th SHAFT GROUP "A"

ITEM	DESCRIPTION	QTY.	ITEM	DESCRIPTION	QTY.
1	2nd and 4th Shaft	1	5	Bearing Spacer	1
2	Bearing Snap Ring	1	6	Front Bearing	1
3	Rear Bearing	1	7	Bearing Snap Ring.....	1
4	2nd and 4th Shaft Gear.....	1			

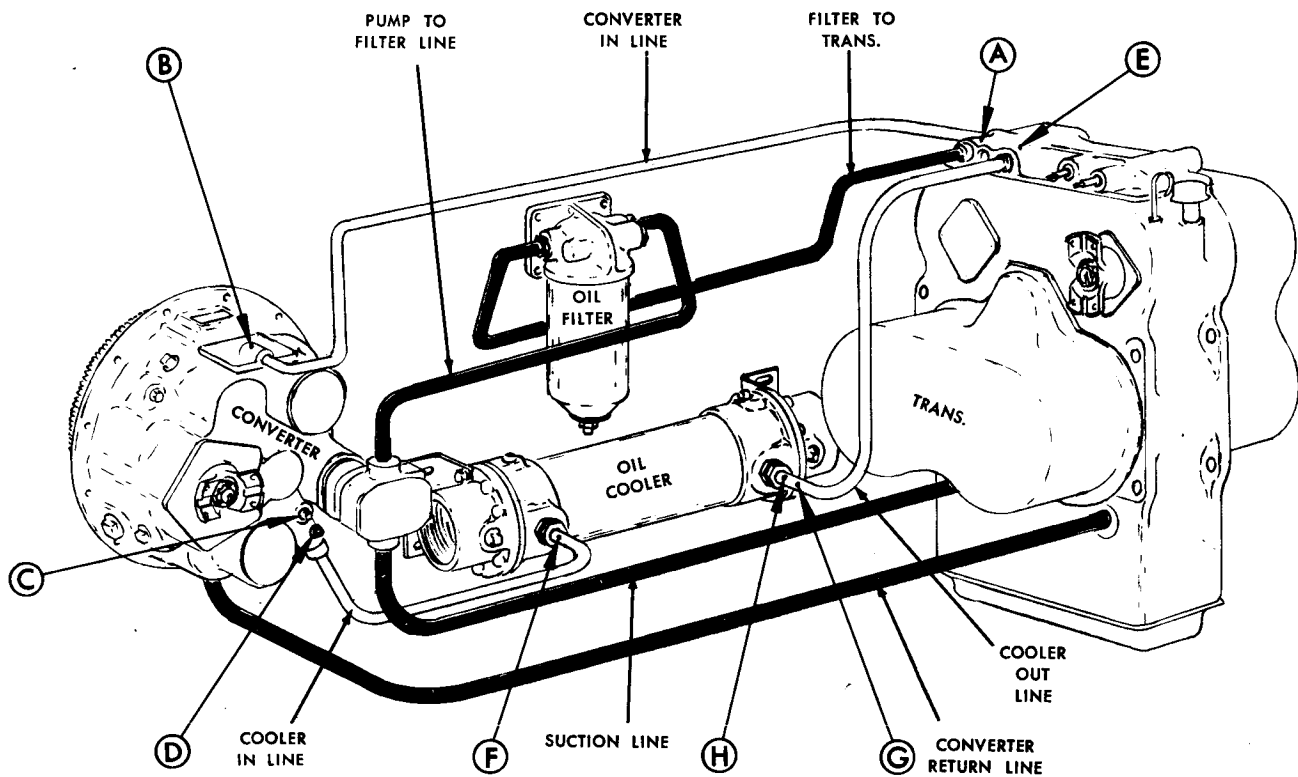
FIG. I 1st and 3rd SHAFT GROUP "B"

ITEM	DESCRIPTION	QTY.	ITEM	DESCRIPTION	QTY.
1	1st and 3rd Shaft	1	5	1st and 3rd Shaft Gear.....	1
2	Bearing Snap Ring	1	6	Front Bearing	1
3	Rear Bearing	1	7	Bearing Snap Ring	1
4	Bearing Spacer	1			

FIG J CHECK POINTS

- | | |
|-------------------------------------|------------------------------|
| A. CLUTCH PRESSURE | E. LUBE PRESSURE |
| B. CONVERTER INLET | F. COOLER INLET PRESSURE |
| C. CONVERTER OUTLET | G. COOLER OUTLET PRESSURE |
| D. CONVERTER TEMPERATURE CONNECTION | H. COOLER OUTLET TEMPERATURE |

HIGH PRESSURE
 LOW PRESSURE
 SUCTION & DRAIN



EXTERNAL PLUMBING & CHECK POINT DIAGRAM

OVERHAUL OF TRANSMISSION ASSEMBLY

The instructions contained herein cover the disassembly and reassembly of the transmission in a sequence that would normally be followed after the unit has been removed from the machine and is to be completely overhauled.

CAUTION: Cleanliness is of extreme importance and an absolute must in the repair and overhaul of this unit. Before attempting any repairs, the exterior of the unit must be thoroughly cleaned to prevent the possibility of dirt and foreign matter entering the mechanism.

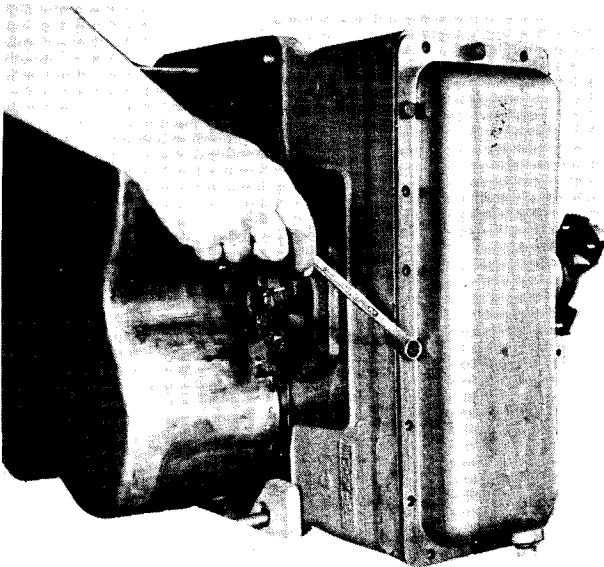
DISASSEMBLY OF THE TRANSMISSION

Figure 1
Remove transmission sump pan bolts.

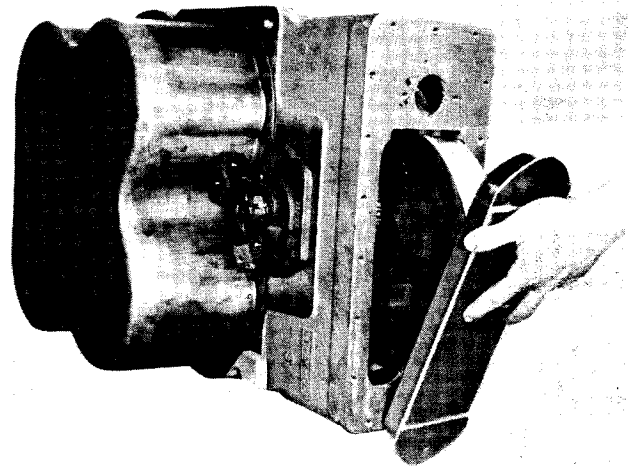


Figure 3
Remove sump screen bolts and sump screen.

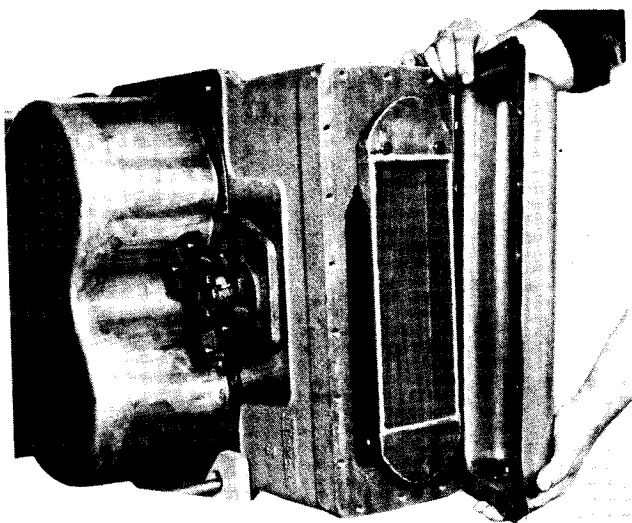


Figure 2
Remove transmission sump pan.

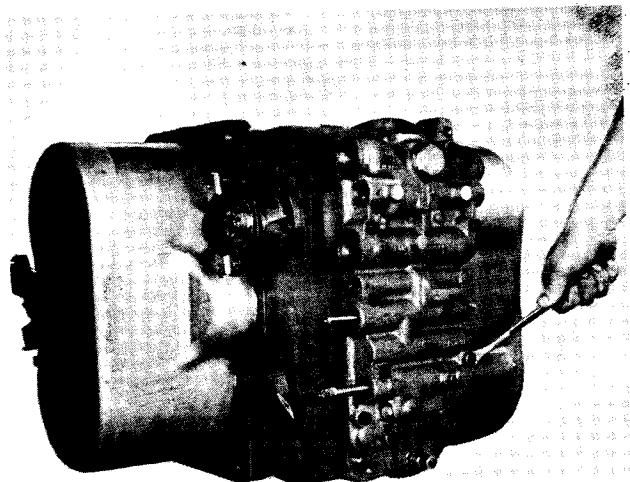


Figure 4
Remove control cover bolts.

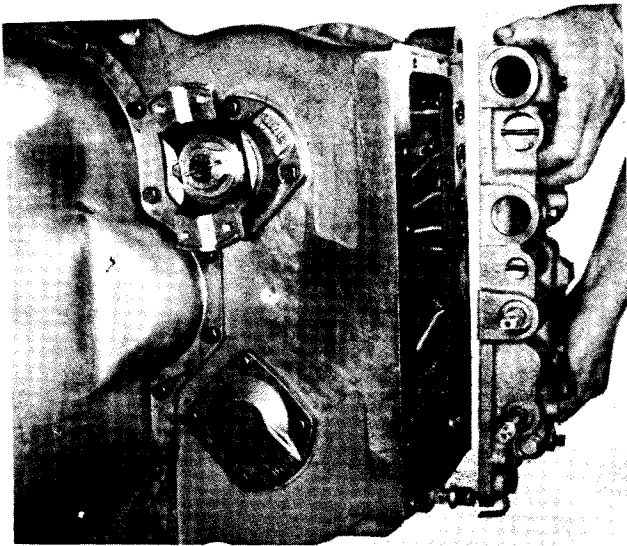


Figure 5

Remove control cover.

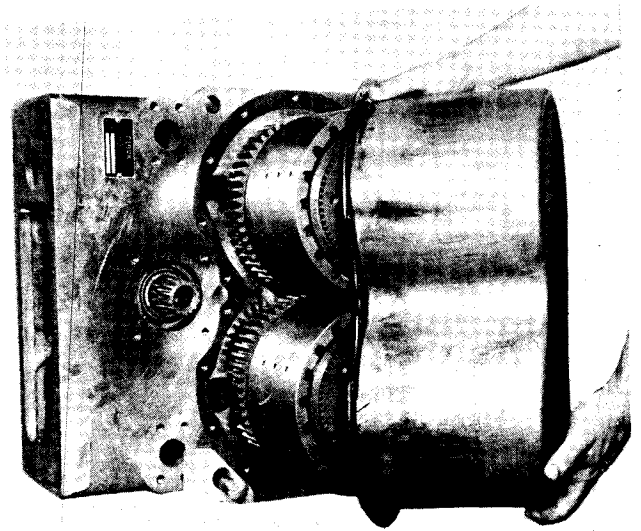


Figure 8

Remove 1st and 2nd clutch cover.

NOTE: All clutches are disassembled in a similar manner. The quantity of clutch discs will differ between the 1st and 2nd clutch and the forward, reverse, 3rd, and 4th. Do not mix 1st and 2nd clutch plates with forward, reverse, 3rd and 4th.

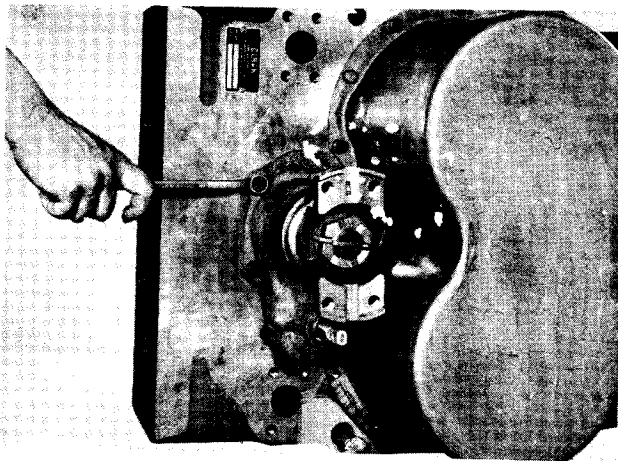


Figure 6

Remove disconnect housing bolts.

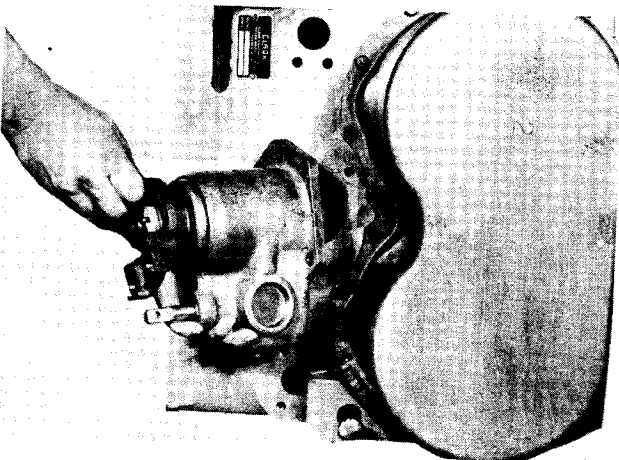


Figure 7

Remove disconnect assembly.

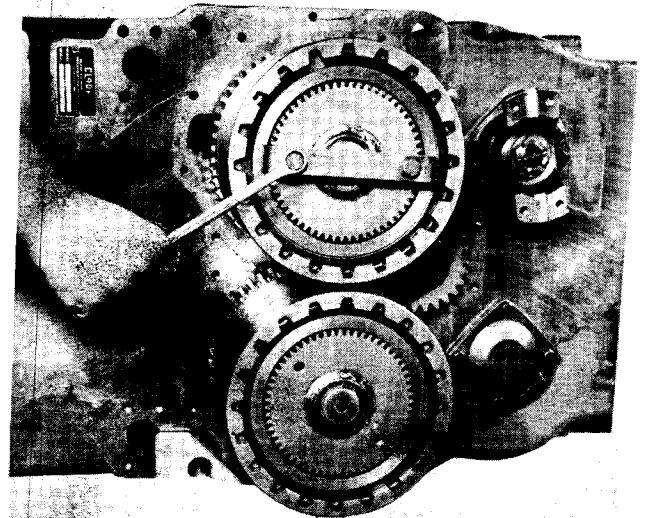


Figure 9

Depress end plate.

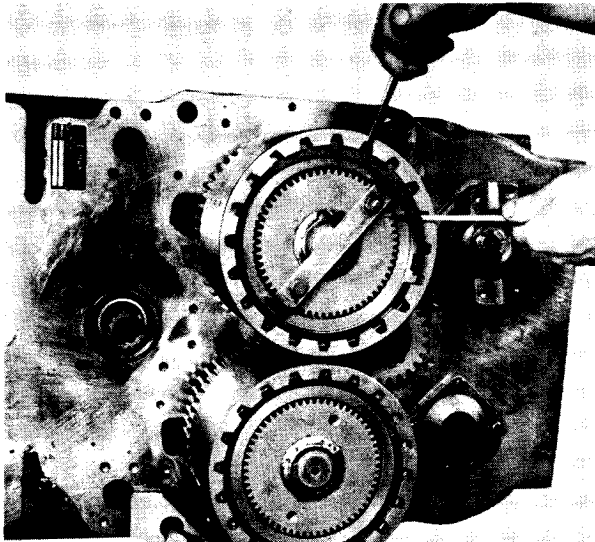


Figure 10

Remove end plate retainer ring.

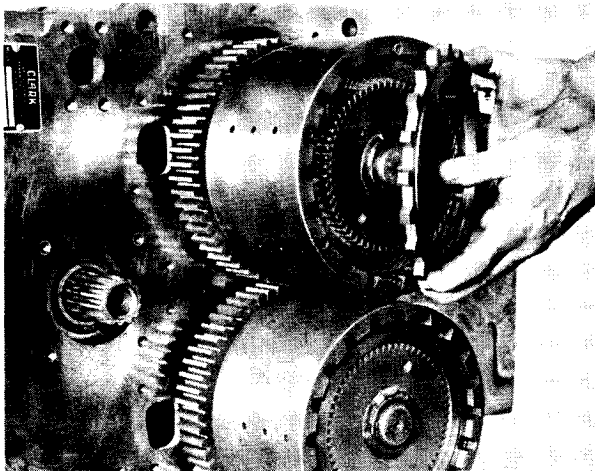


Figure 11

Remove end plate.

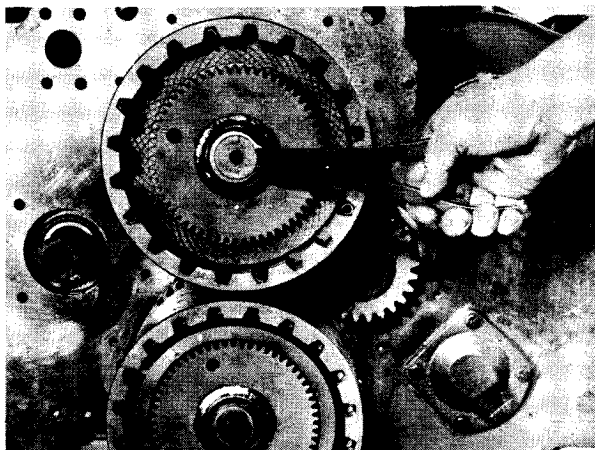


Figure 12

Remove clutch disc hub retainer ring.

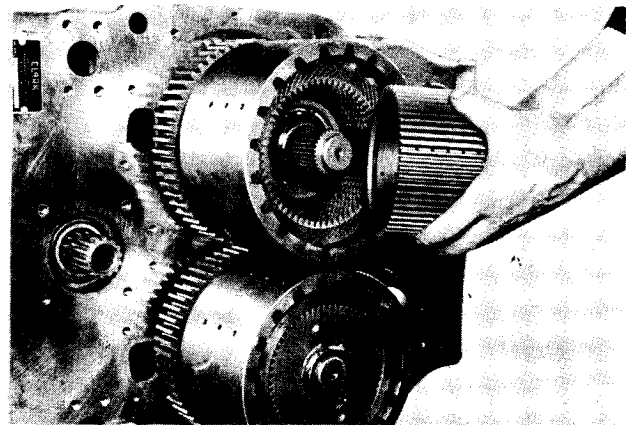


Figure 13

Remove clutch disc hub. Remove release springs, guide pins, and inner and outer clutch disc.

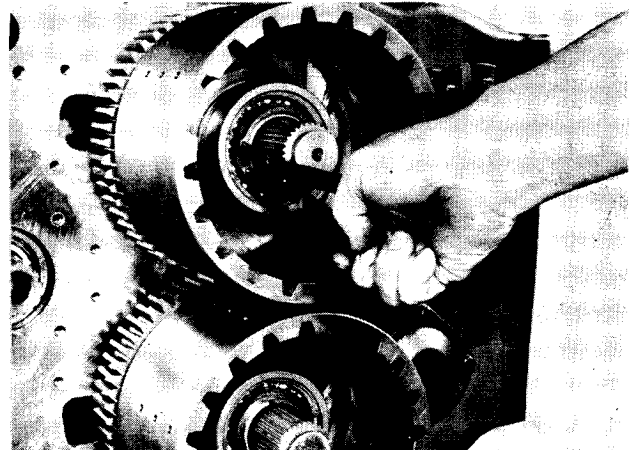


Figure 14

Remove clutch drum hub retainer ring and retainer washer.

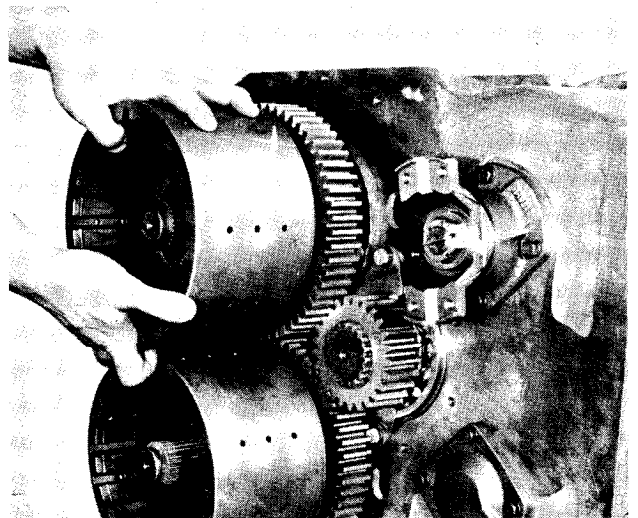


Figure 15

Remove clutch drum assembly from clutch support.

NOTE: If clutch drum hub gear (1st and 2nd clutch only,) support bearings, or piston ring outer race are to be replaced, use Figures 16 through 20, if replacement is not necessary, disregard and continue on with Figure 21.

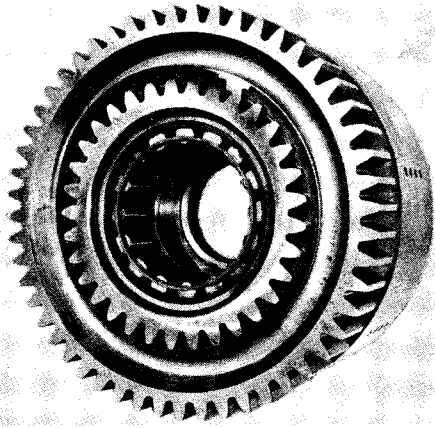


Figure 16

Remove clutch drum hub gear retainer ring.

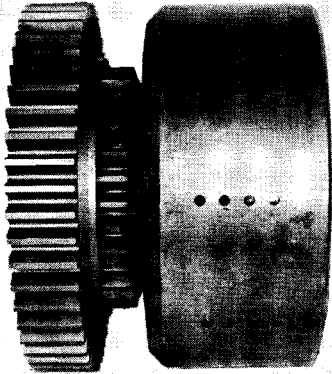


Figure 17

Remove clutch drum hub gear.

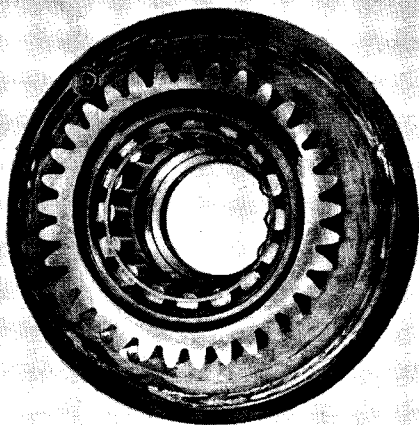


Figure 18

Remove drum support roller bearing retainer ring.

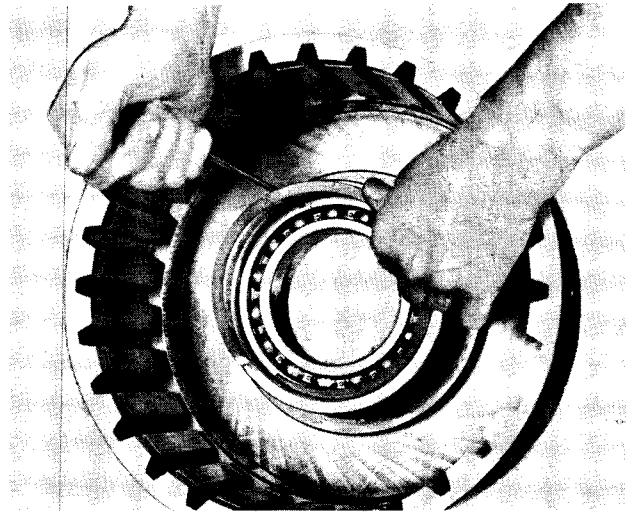


Figure 19

Remove drum support ball bearing retainer ring. Press or drive roller and ball bearing from clutch drum.

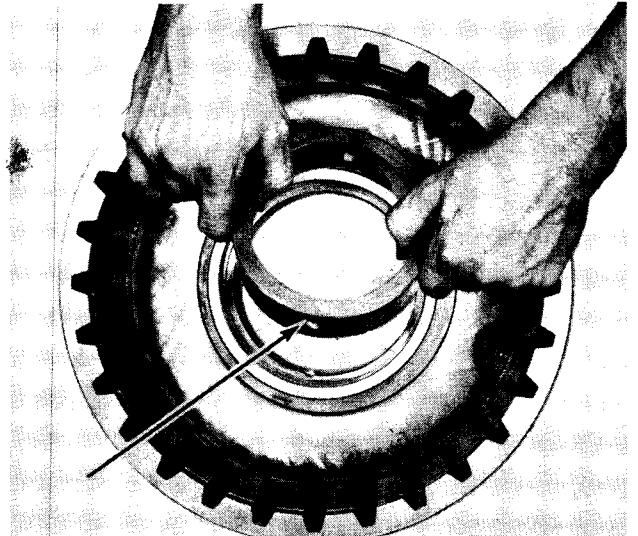


Figure 20

Press piston ring outer race from clutch drum. **CAUTION:** Do not lose ball (see arrow).

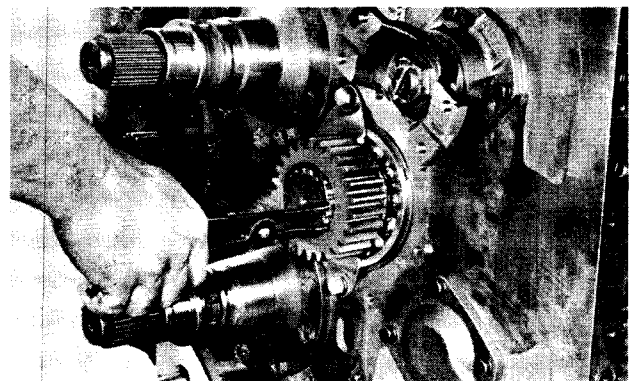


Figure 21

Remove idler gear retainer ring, and idler gear.

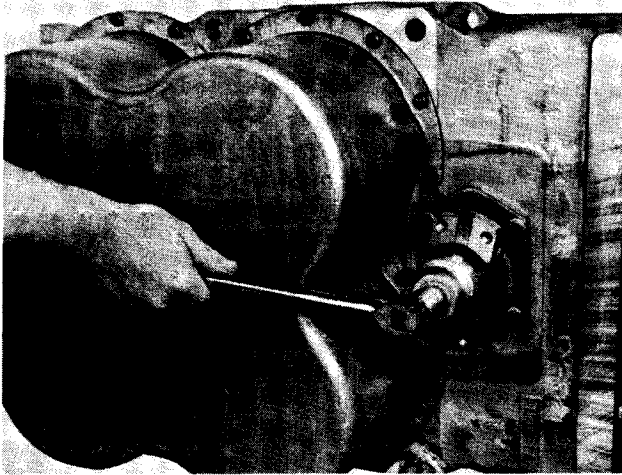


Figure 22

Lock transmission gears with a soft bar and remove output flange nut and flange

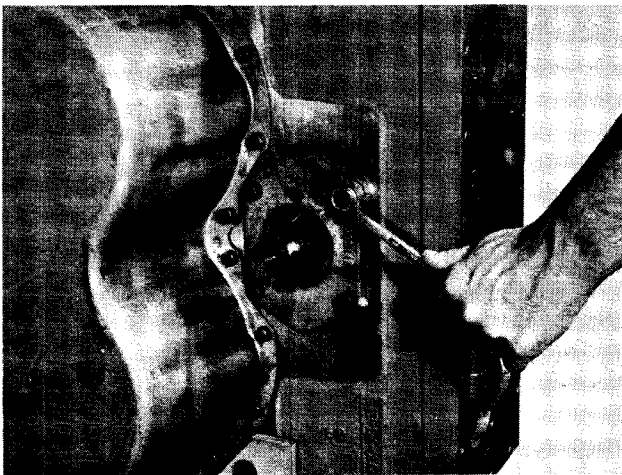


Figure 23

Remove output shaft bearing cap bolts and bearing cap.

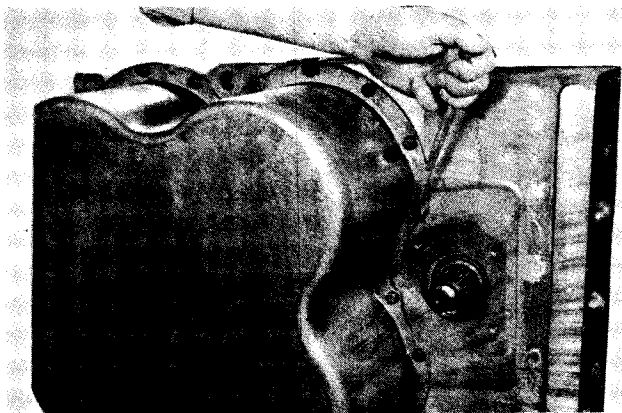


Figure 24

Remove forward, reverse, 3rd and 4th clutch cover bolts.

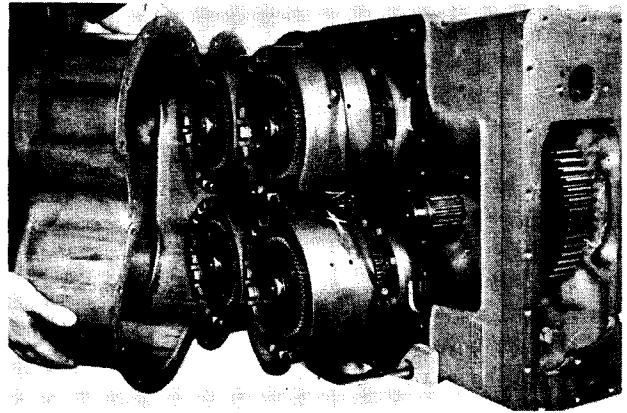


Figure 25

Remove clutch cover. Proceed with clutch disassembly as explained in previous text (Figure 9 through 15 and Figure 18 through 20).

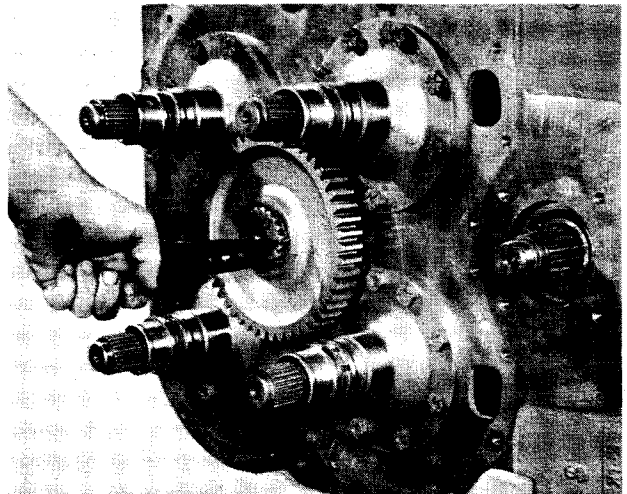


Figure 26

Remove idler gear retainer ring and idler gear.

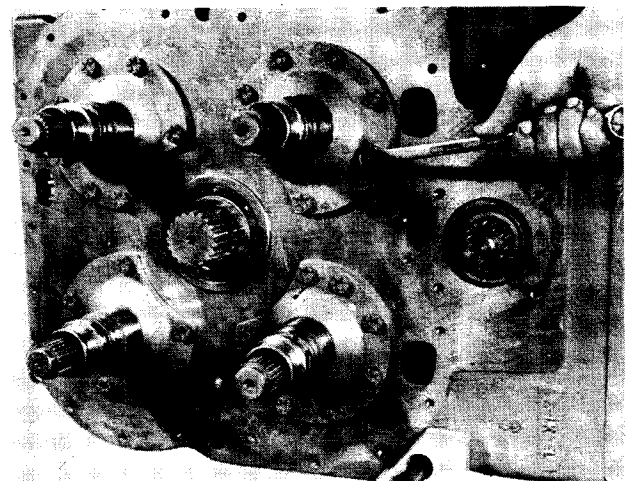


Figure 27

Remove clutch support bolts.

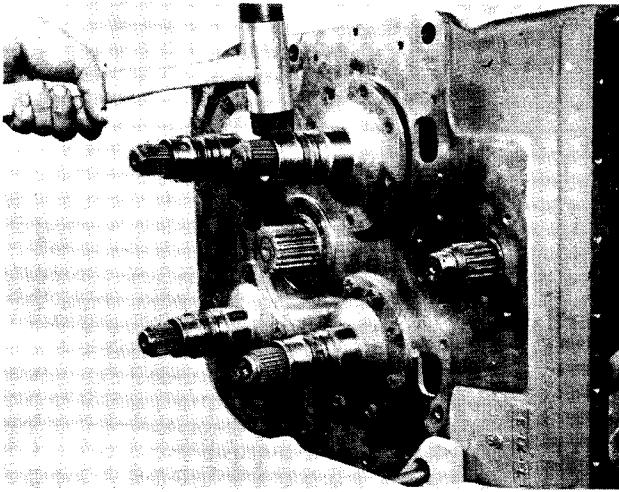


Figure 28

Using a soft hammer, tap clutch support top and bottom to remove same from case.

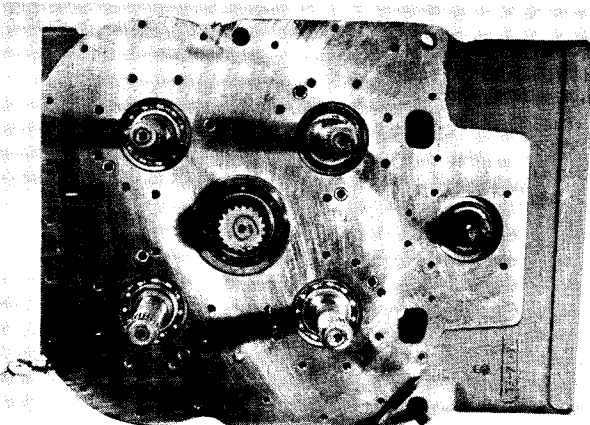


Figure 29

Side view showing all external parts removed.

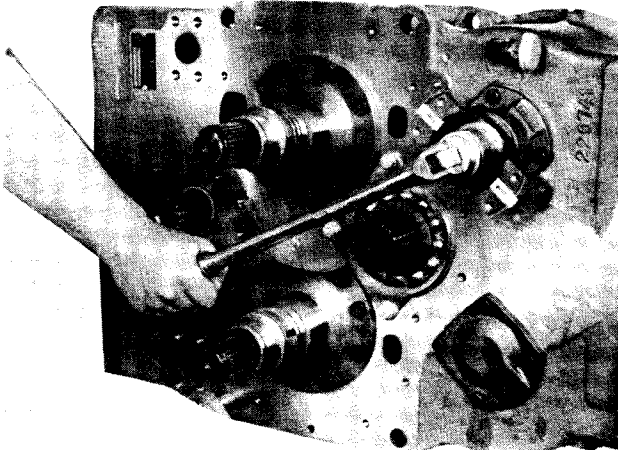


Figure 30

Lock transmission gears with a soft bar and remove input flange nut and flange.

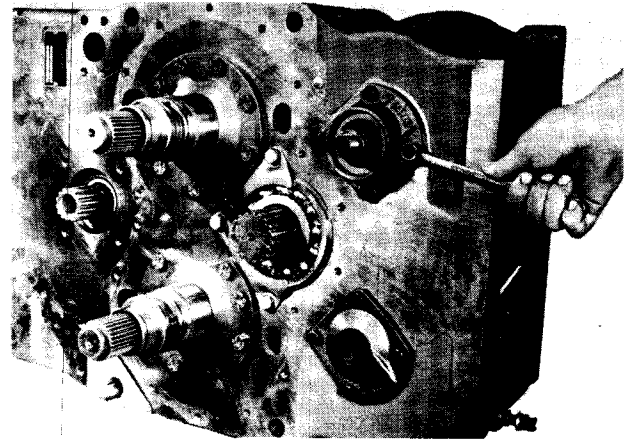


Figure 31

Remove input shaft bearing cap bolts. Remove bearing cap and oil seal assembly.

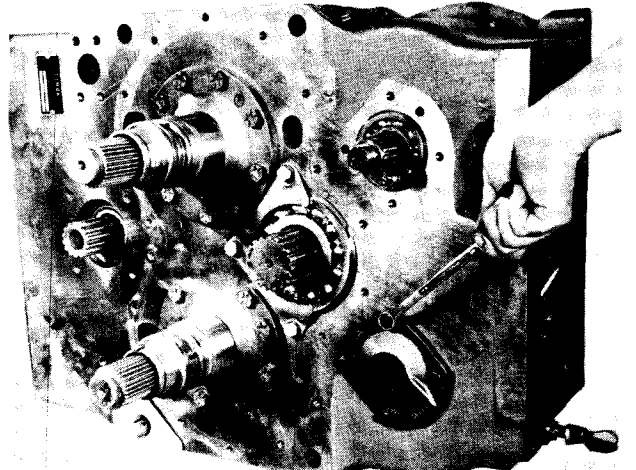


Figure 32

Remove reverse shaft bearing cap bolts and bearing cap.

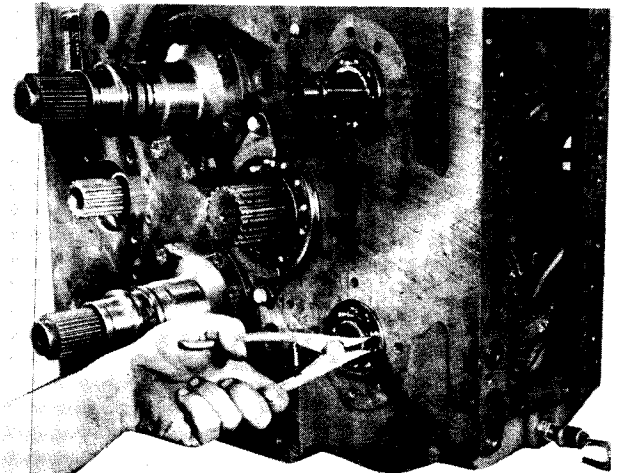


Figure 33

Remove reverse shaft bearing retainer ring.

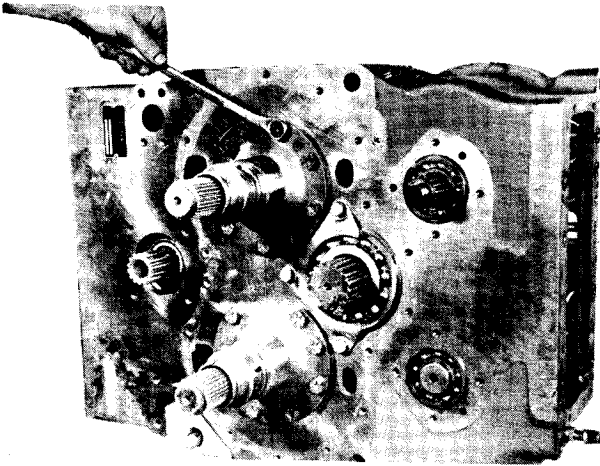


Figure 34

Remove 1st and 2nd clutch shaft support bolts.

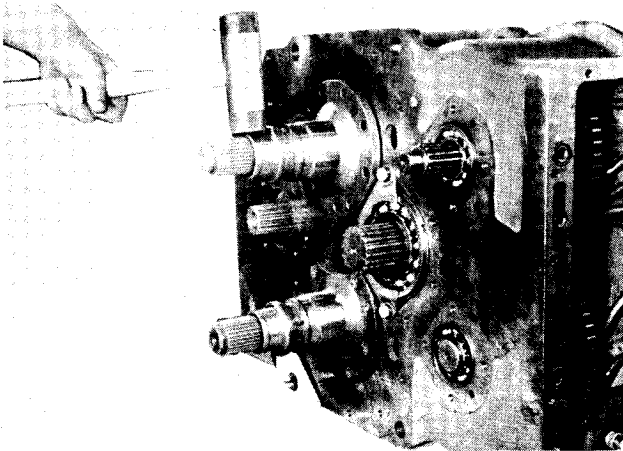


Figure 35

Using a soft hammer, tap clutch support top and bottom to remove same from case.

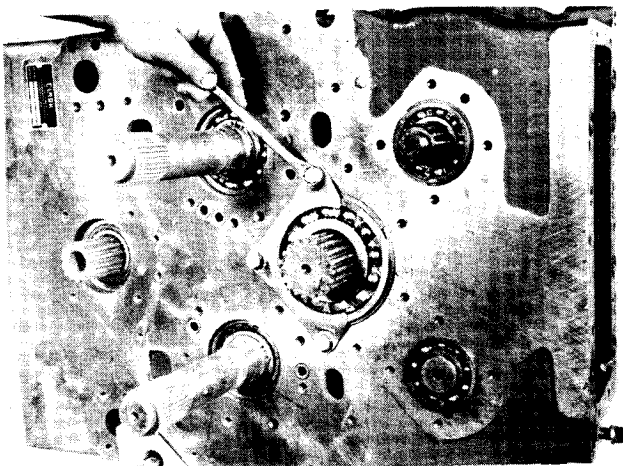


Figure 36

Remove idler bearing retainer bolts, and retainer. Before removing the input shaft, note its location, re-assemble in the same location.

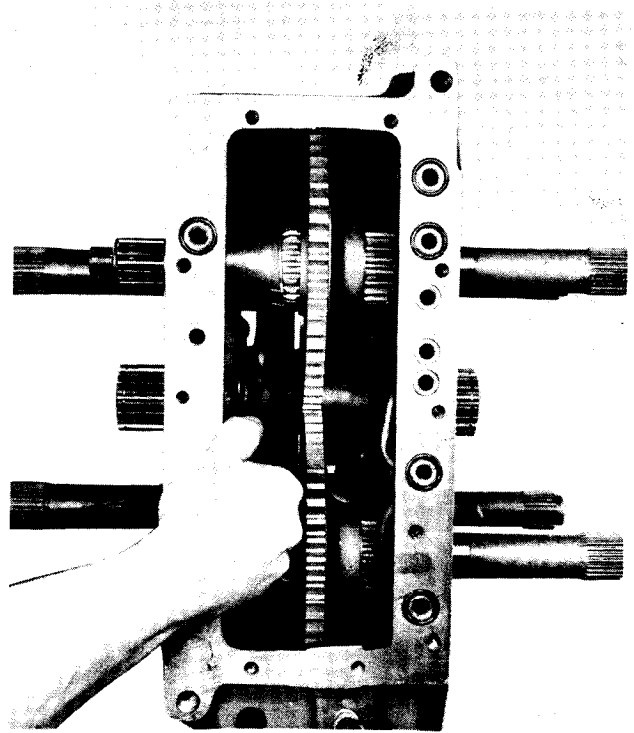


Figure 37

Remove input gear retainer ring from ring groove.

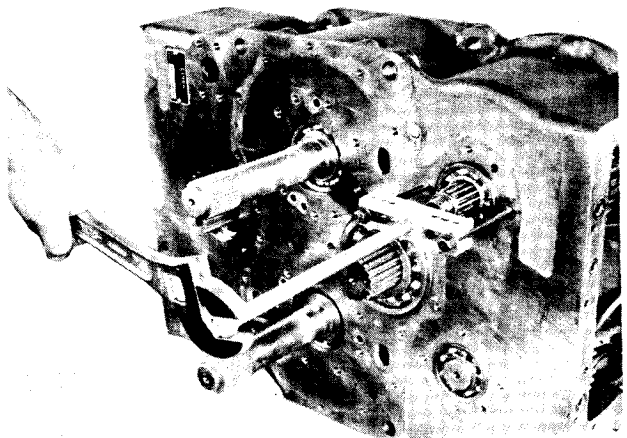


Figure 38

Using a suitable shaft pusher tool, remove input shaft and gear from case.

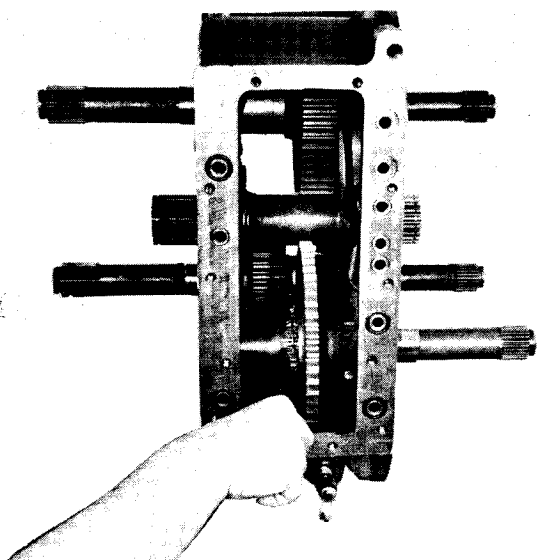


Figure 39

Remove reverse gear retainer ring from ring groove.

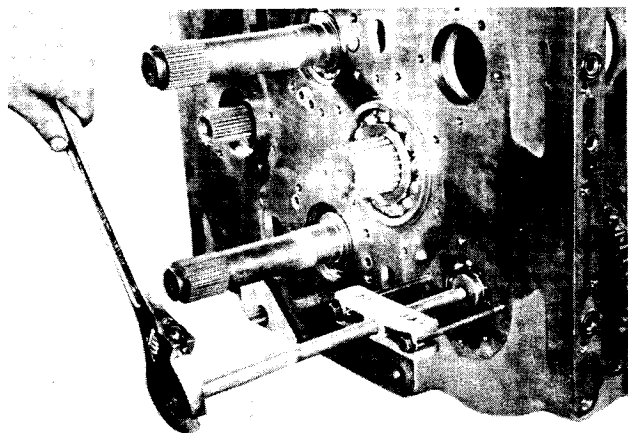


Figure 40

Using a suitable shaft pusher tool, remove reverse shaft and gear from case.

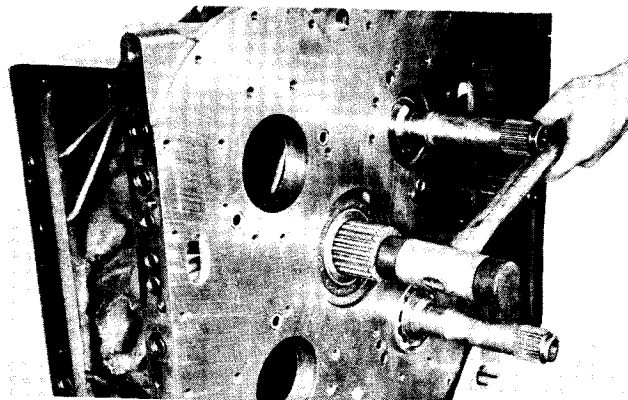


Figure 41

Tap idler shaft and bearing through case until bearing on opposite side is out at least one half an inch.

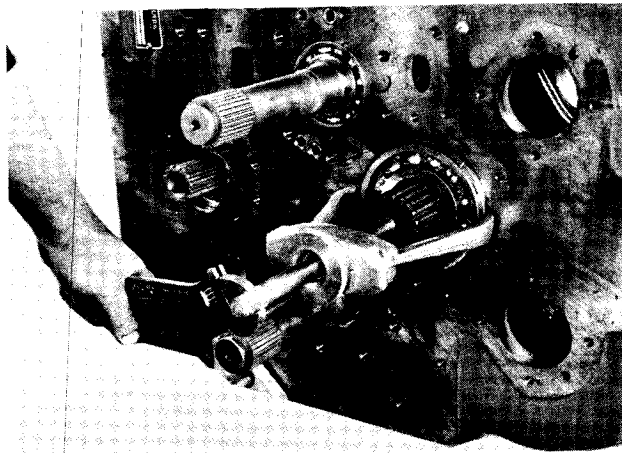


Figure 42

Using a suitable bearing puller, remove bearing from shaft.

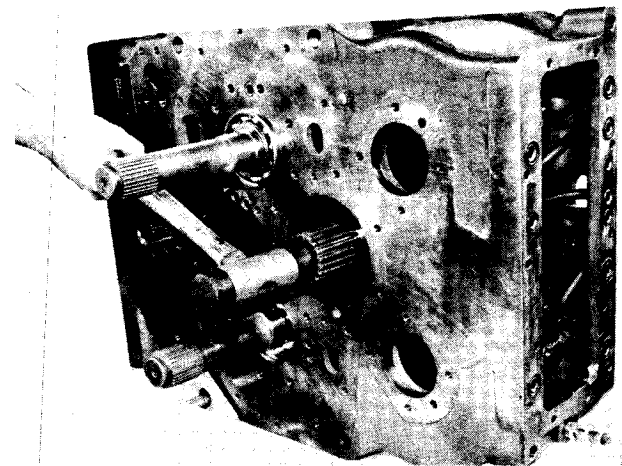


Figure 43

Tap idler shaft and bearing from case.

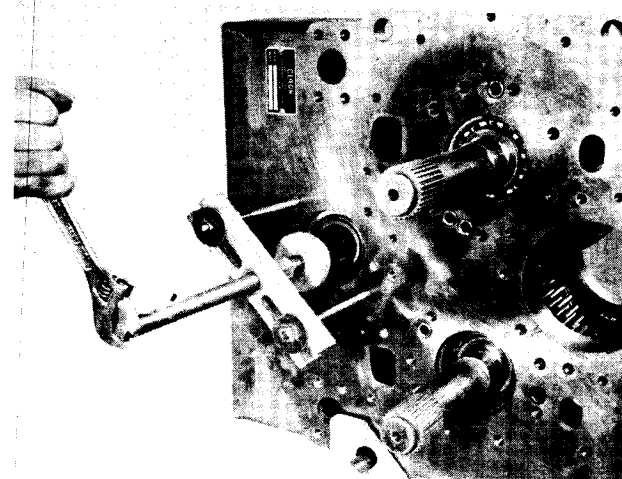


Figure 44

Block output shaft gears and using a suitable shaft pusher tool, remove output shaft and gears from case.

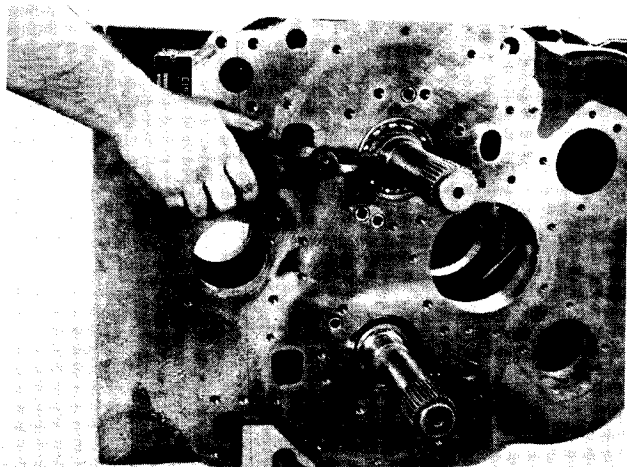


Figure 45

Remove 2nd speed bearing retainer ring. Tap on opposite end of shaft until bearing is out of case.

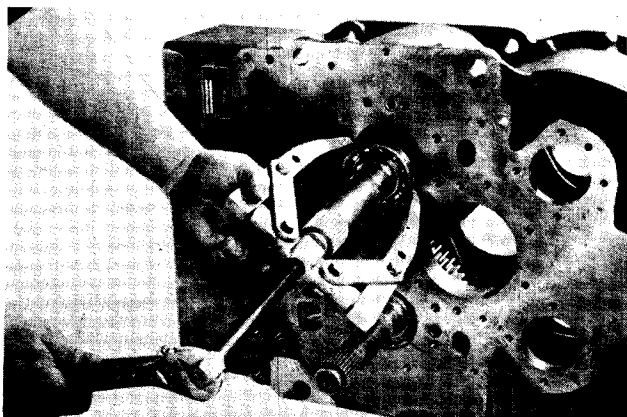


Figure 46

Using a suitable bearing puller, remove bearing from shaft. Push shaft through 2nd speed gear and out of case.

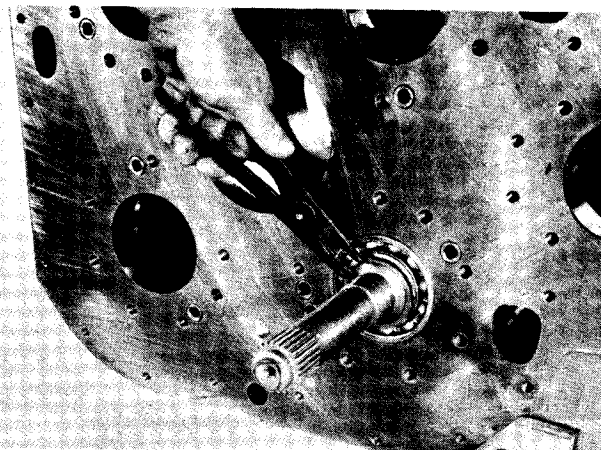


Figure 47

Remove 3rd speed bearing retainer ring. (Opposite side of second speed ring.) Tap on opposite end of shaft until bearing is out of case.

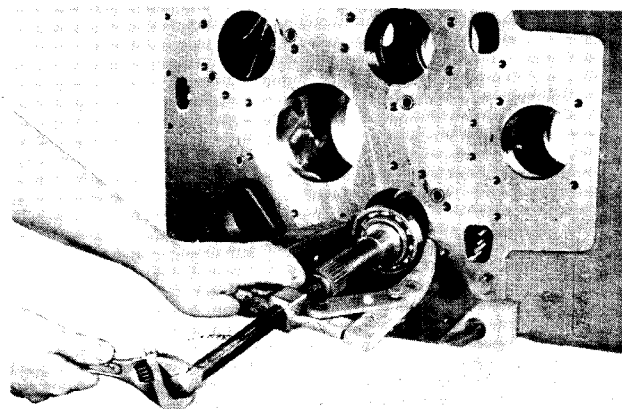


Figure 48

Using a suitable bearing puller, remove bearing from shaft. Push shaft through 3rd speed gear and out of case.

DISASSEMBLY OF CONTROL COVER

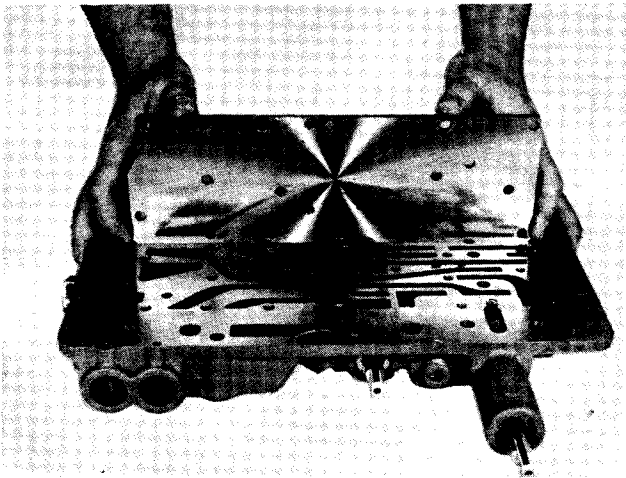


Figure 49

Remove bolts from oil circuit plate. Remove oil circuit plate. **CAUTION:** Do not lose detent springs.

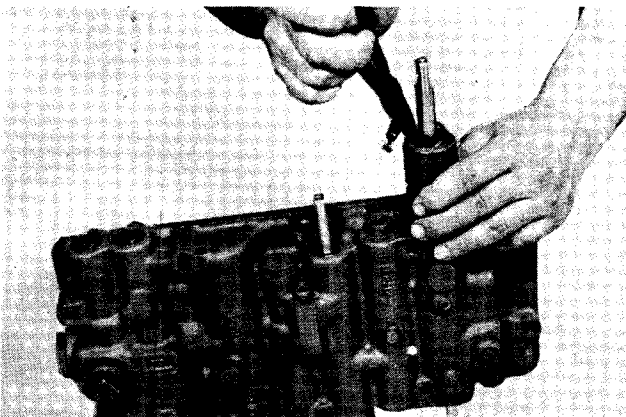


Figure 50

Remove speed selector valve assembly retainer ring.

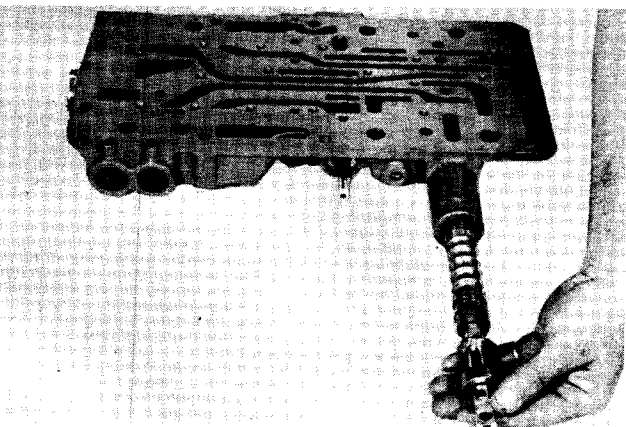


Figure 51

Tap lightly on opposite end of speed selector valve. Valve and valve oil seal will come out together.

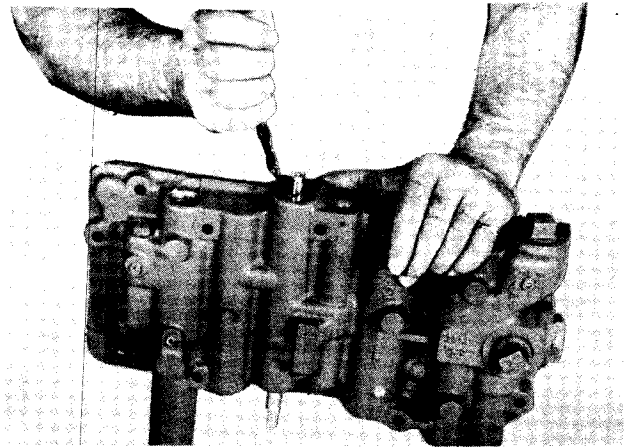


Figure 52

Remove forward and reverse selector valve retainer ring.

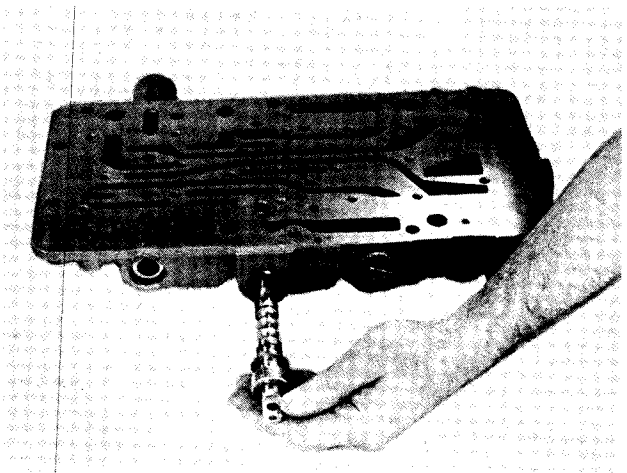


Figure 53

Tap lightly on opposite end of forward and reverse selector valve. Valve and valve oil seal will come out together.

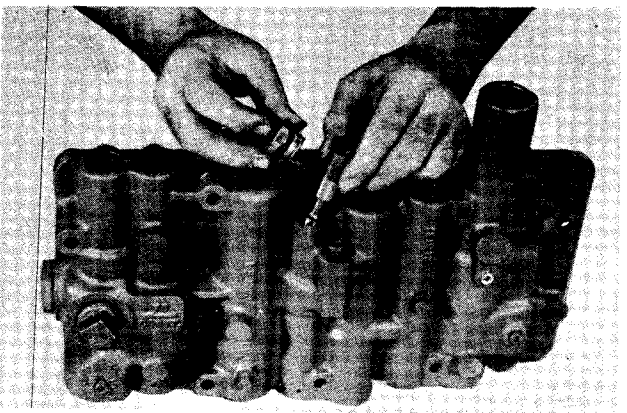


Figure 54

Remove shut-off valve plug and "O" ring. Remove shut-off valve.

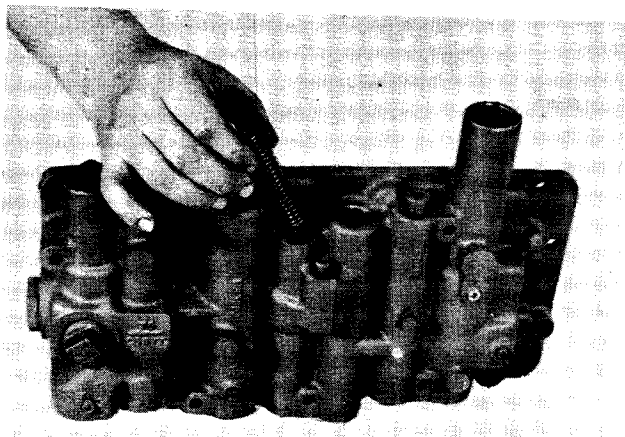


Figure 55

Remove shut-off valve spring.

CAUTION: When removing roll pins, it is recommended a press be used to depress valve stop, valve and spool springs.

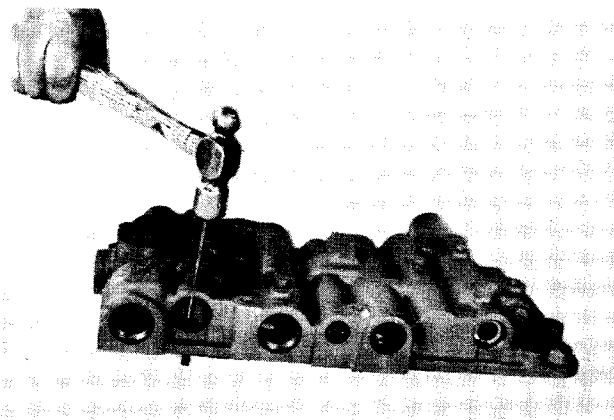


Figure 58

Remove roll pin on opposite end. Depressing valve stop is not necessary as the springs were removed in Figure 57.

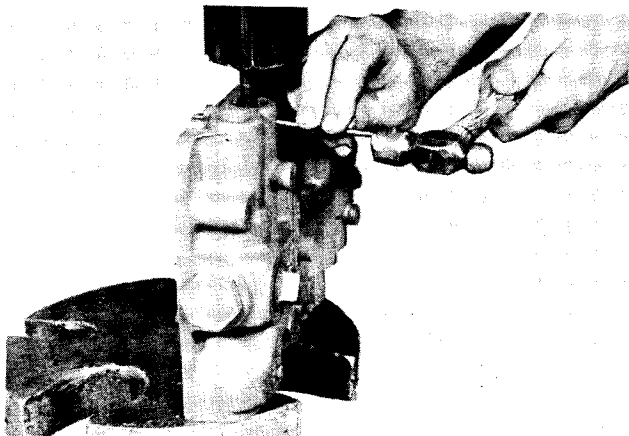


Figure 56

Depress regulating valve spring stop and spring. Remove roll pin.

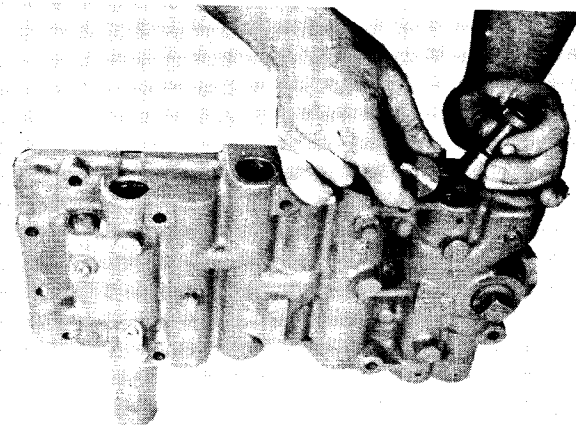


Figure 59

Remove regulating valve stop and valve from control housing.

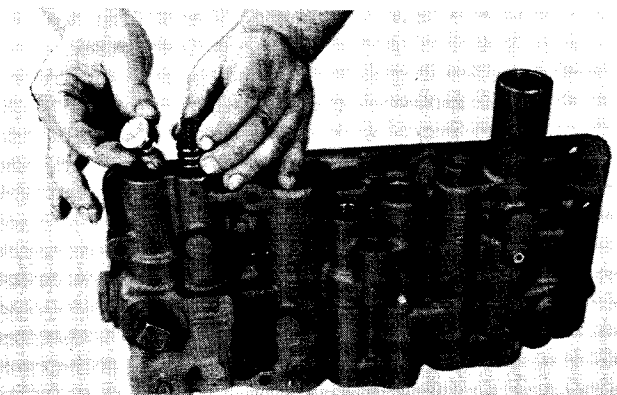


Figure 57

Release arbor press slowly, springs will push spring stop from control housing. Remove spring stop and inner and outer spring.

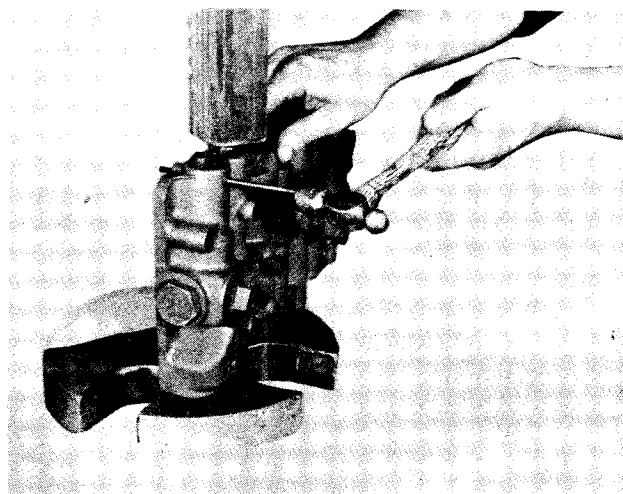


Figure 60

Depress safety valve spring and spring stop.

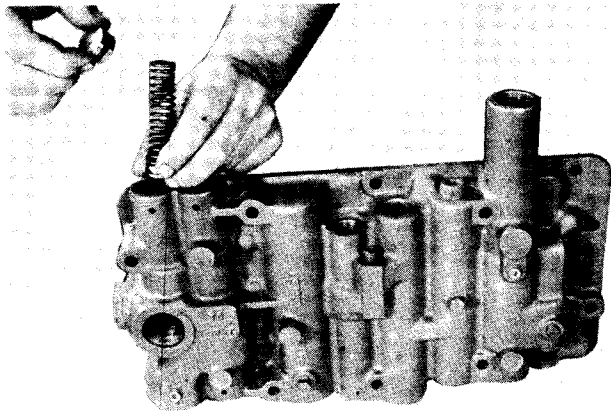


Figure 61

Remove safety valve spring stop, valve spring, and safety ball valve.

TRANSMISSION INTERNAL TUBING

These tubes are not to be removed unless damaged. They should, however, be cleaned and checked for leaks when transmission is disassembled. The tubes are divided into two groups. The high pressure or clutch pressure lines and the low or lubricating pressure lines.

When necessary to replace any tubes, tool CE-805 is required. The procedure for using tool is as follows:

1. Install tubing in housing with end flush with case.
2. Slide collar over end of tube and press into bore of case.

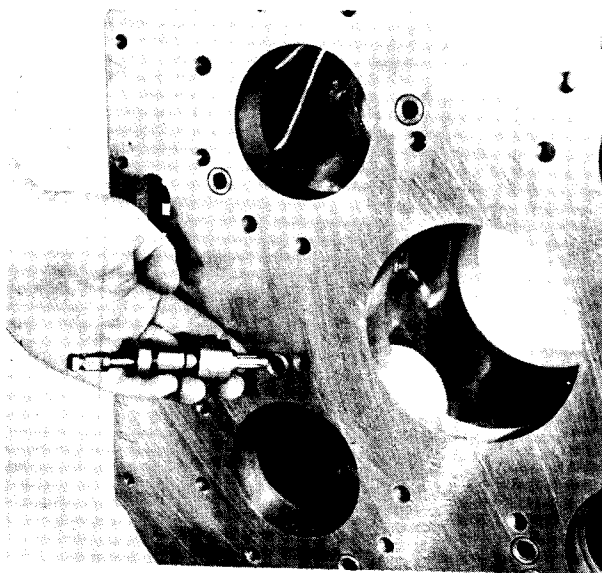


Figure 62

Pull mandrel on tool all the way back and insert tool in tube.

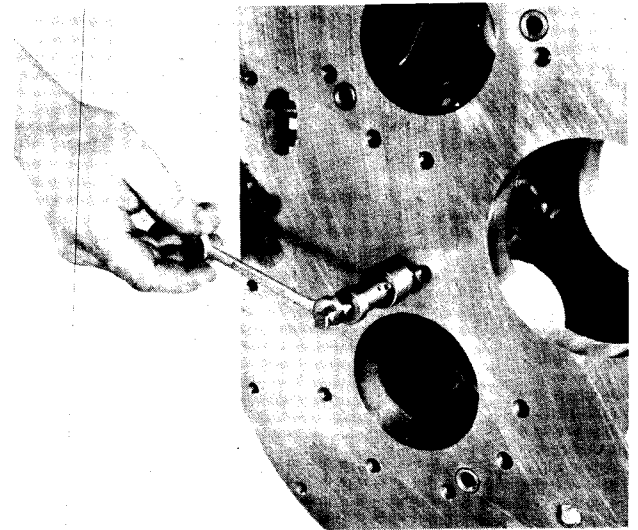


Figure 63

Turn mandrel with hand until tool is firmly seated in tube. Using a 3/8" wrench, turn mandrel as far as possible.

Use this procedure to install all tubes in housing.

Principle of Tool

Tool has roller which expands when mandrel is inserted. As mandrel is turned, the rollers expand against the internal bore of tubing. This forces tube to expand against collar which has a groove on inside diameter: When tube is expanded into this groove it is locked into position.

Cleaning and Repair of Tool

This tool is a precision instrument and must be treated as such. After each use, remove mandrel and rollers and flush tool with cleaning solvent. Inspect rollers and mandrel for chips and flaking. If rollers or mandrel need to be replaced, they may be purchased from **Air Tool Division, Dresser Industries, Inc., 302 S. Center St., Springfield, Ohio 45501. Phone 513-323-4981. Attn: Order Dept.**

CLEANING AND INSPECTION

CLEANING

Clean all parts thoroughly using solvent type cleaning fluid. It is recommended that parts be immersed in cleaning fluid and slushed up and down slowly until all old lubricant and foreign material is dissolved and parts are thoroughly cleaned.

CAUTION: Care should be exercised to avoid skin rashes, fire hazards and inhalation of vapors when using solvent type cleaners.

Bearings

Remove bearings from cleaning fluid and strike larger side of cone flat against a block of wood to dislodge solidified particles of lubricant. Immerse again in cleaning fluid to flush out particles. Repeat above operation until bearings are thoroughly clean. Dry bearings using moisture-free compressed air. Be careful to direct air stream across

bearing to avoid spinning. Do not spin bearings when drying. Bearings may be rotated slowly by hand to facilitate drying process.

Housings

Clean interior and exterior of housings, bearing caps, etc., thoroughly. Cast parts may be cleaned in hot solution tanks with mild alkali solutions providing these parts do not have ground or polished surfaces. Parts should remain in solution long enough to be thoroughly cleaned and heated. This will aid the evaporation of the cleaning solution and rinse water. Parts cleaned in solution tanks must be thoroughly rinsed with clean water to remove all traces of alkali. Cast parts may also be cleaned with steam cleaner.

CAUTION: Care should be exercised to avoid inhalation of vapors and skin rashes when using alkali cleaners.

All parts cleaned must be thoroughly dried immediately by using moisture-free compressed air or soft, lintless absorbent wiping rags free of abrasive materials such as metal filings, contaminated oil or lapping compound.

INSPECTION

The importance of careful and thorough inspection of all parts cannot be overstressed. Replacement of all parts showing indication of wear or stress will eliminate costly and avoidable failures at a later date.

Bearings

Carefully inspect all rollers, cages and cups for wear, chipping or nicks to determine fitness of bearings for further use. Do not replace a bearing cone or cup individually without replacing the mating cup or cone at the same time. After inspection, dip bearings in Automatic Transmission Fluid and wrap in clean lintless cloth or paper to protect them until installed.

Oil Seals, Gaskets, Etc.

Replacement of spring load oil seals, "O" rings, metal sealing rings, gaskets and snap rings is more economical when unit is disassembled than premature overhaul to replace these parts at a future time. Further loss of lubricant through a worn seal may result in failure of other more expensive parts of the assembly. Sealing members should be handled carefully, particularly when being installed. Cutting, scratching, or curling under of lip of seal seriously impairs its efficiency. Apply a thin coat of Permatex No. 2 on the outer diameter of the oil seal to assure an oil tight fit into the retainer. When assembling new metal type sealing rings, same should be lubricated with coat of chassis grease to stabilize rings in their grooves for ease of assembly of mating members. Lubricate all "O" rings and seals with Automatic Transmission Fluid before assembly.

Gears and Shafts

If magna-flux process is available, use process to check parts. Examine teeth on all gears carefully for wear, pitting, chipping, nicks, cracks or scores. If gear teeth show spots where case hardening is worn through or cracked, replace with new gear. Small nicks may be removed with

suitable hone. Inspect shafts to make certain they are not sprung, bent, or splines twisted, and that shafts are true.

Housing, Covers, etc.

Inspect housings, covers and bearing caps to be certain they are thoroughly cleaned and that mating surfaces, bearing bores, etc., are free from nicks or burrs. Check all parts carefully for evidence of cracks or condition which would cause subsequent oil leaks or failures.

REASSEMBLY OF TRANSMISSION

Instructions given below on reassembly of components of transmission assembly are given in the sequence that must be followed in rebuilding. Principle of operations cited and views shown are similar and parallel on all shafts. The various drive shafts are assembled in the following order:

1. Second and Fourth Shaft—"A"
2. First and Third Shaft—"B"
3. Idler Shaft—"I"
4. Output Shaft—"O"
5. Reverse Shaft—"R"
6. Input Shaft—"F"

REASSEMBLY OF 2nd AND 4th SHAFT

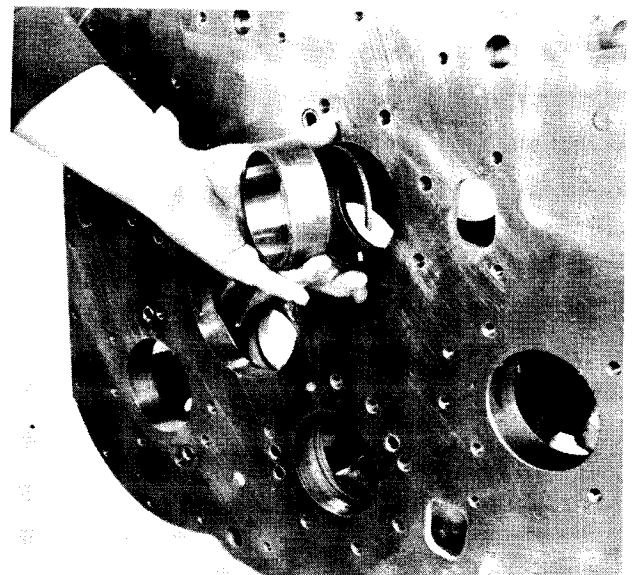


Figure 64

Install 4th speed bearing outer race locating ring (rear side of case).

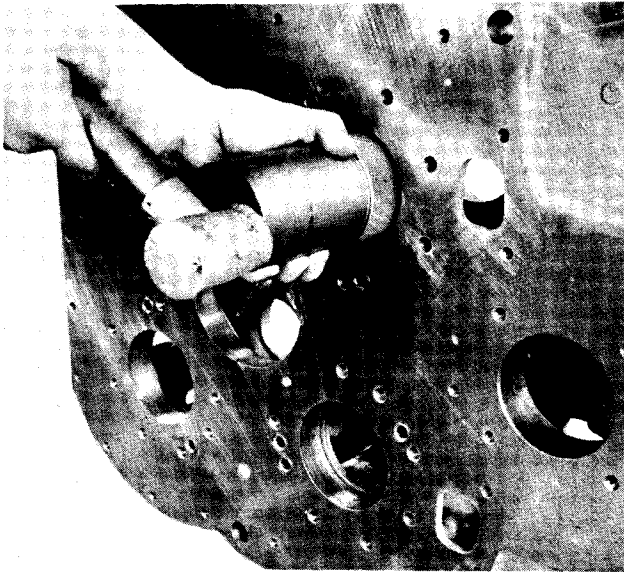


Figure 65
Install 4th speed bearing outer race.

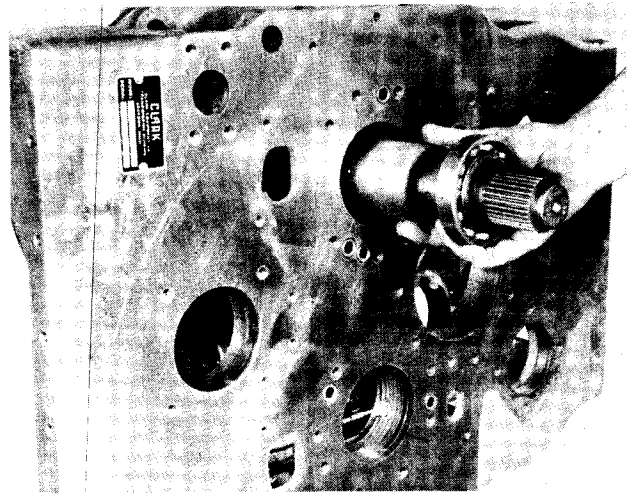


Figure 67
Install bearing spacer and bearing on shaft.

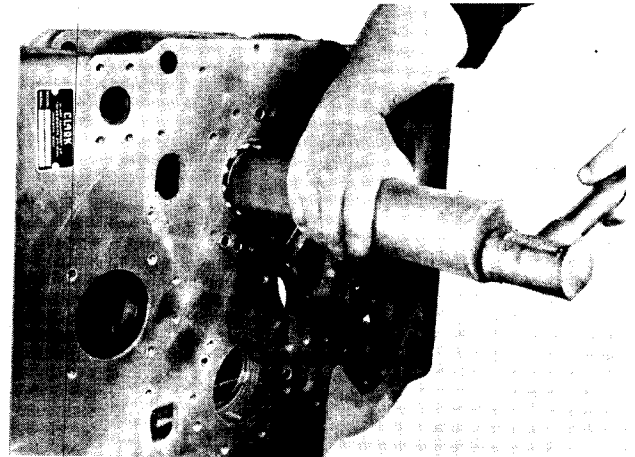


Figure 68
Block shaft on rear of case and drive bearing into position.

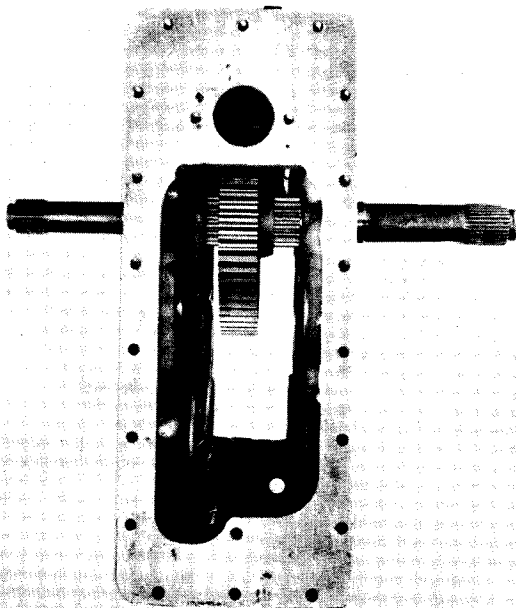


Figure 66
Install 2nd and 4th shaft and roller bearing assembly in case and through gear (hub of gear toward front of case).

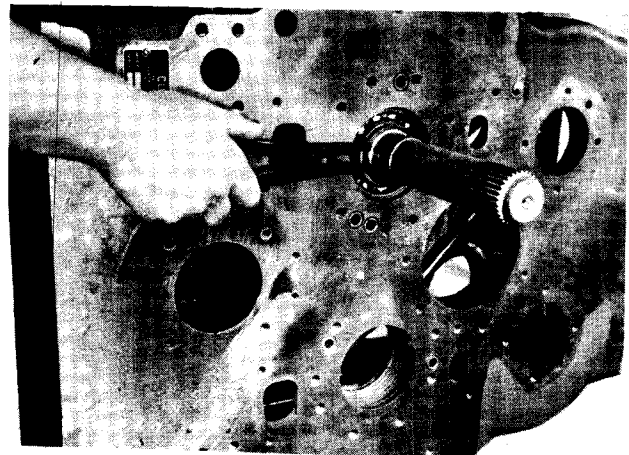


Figure 69
Install bearing retainer ring.

REASSEMBLY OF 1st AND 3rd SHAFT

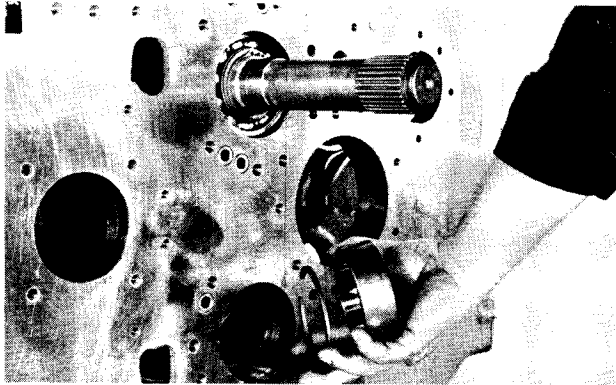


Figure 70

Install 1st speed bearing outer race locating ring (front side of case).

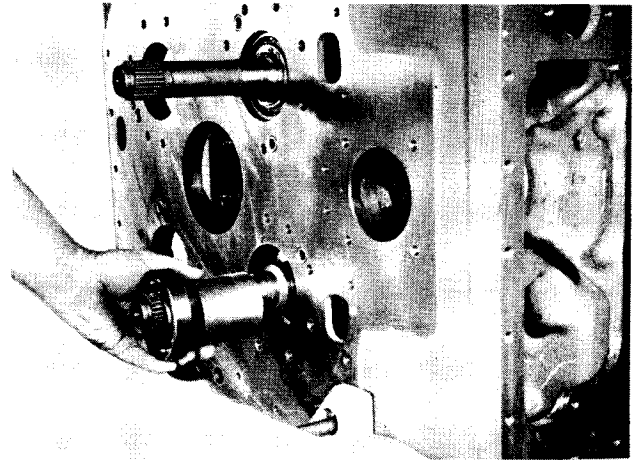


Figure 73

Install bearing spacer and bearing on shaft.

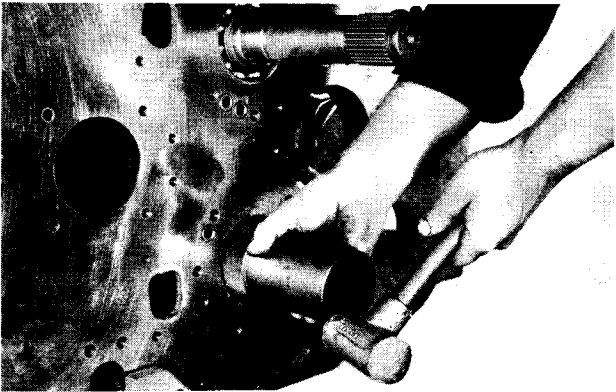


Figure 71

Install first speed bearing outer race.

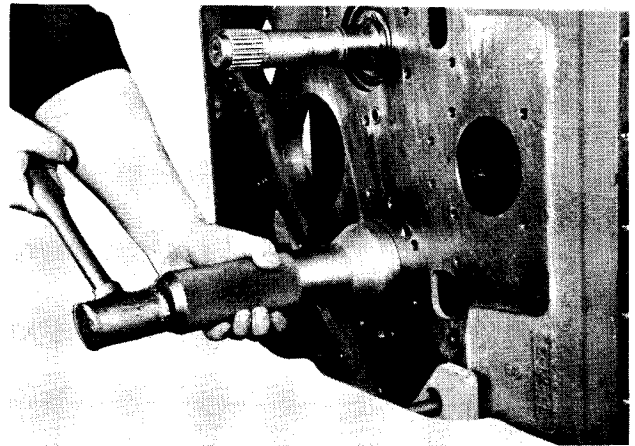


Figure 74

Block shaft on front of case and drive bearing into position.

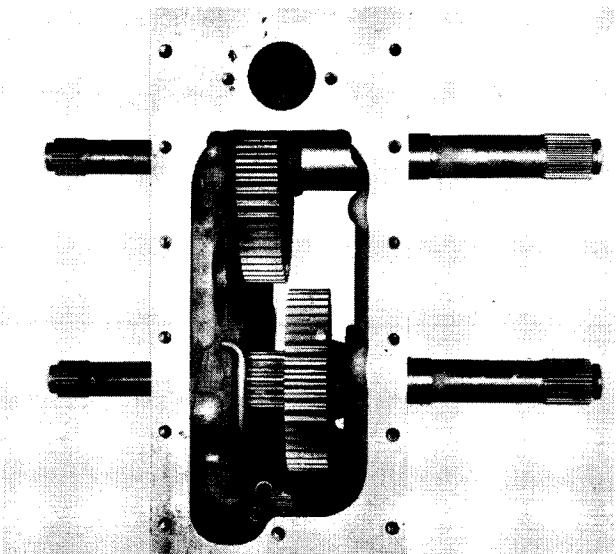


Figure 72

Install 1st and 3rd shaft and roller bearing assembly in case and through gear (hub of gear toward front of case).

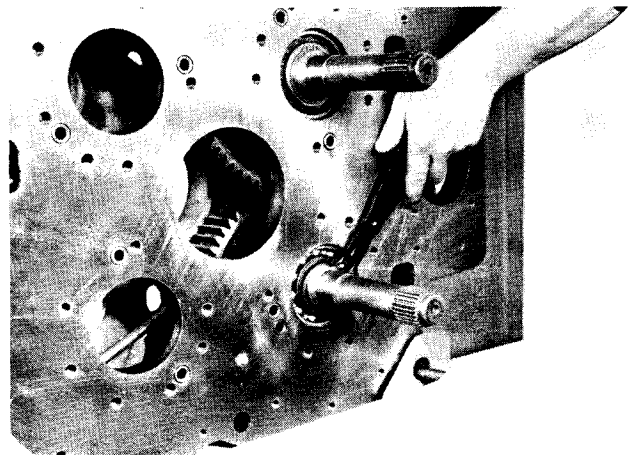


Figure 75

Install bearing retainer ring.

REASSEMBLY OF IDLER SHAFT

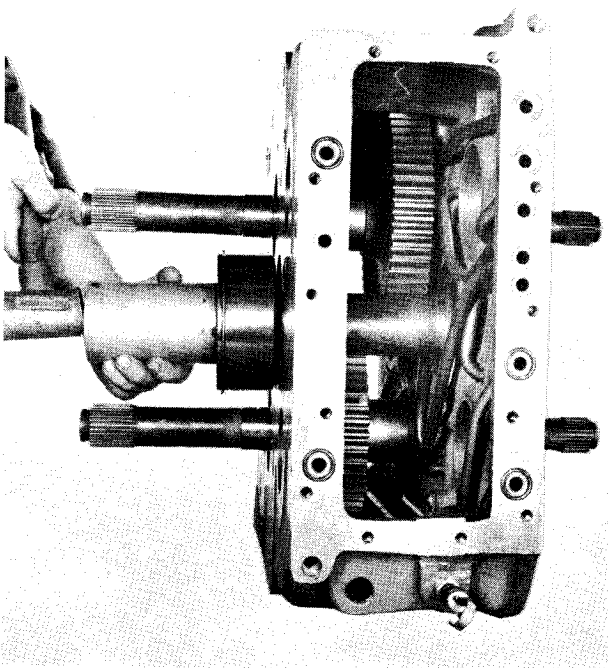


Figure 76

Install idler shaft, spacer and rear bearing in transmission case. Block shaft on rear of case and drive bearing on front of shaft.

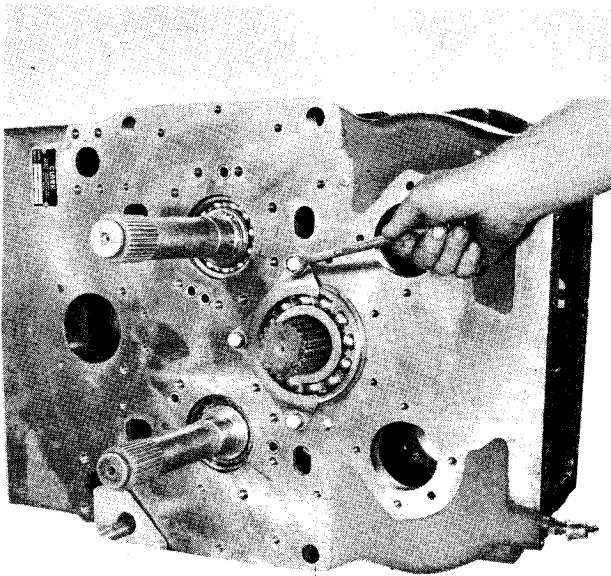


Figure 77

Install bearing retainer and retainer bolts. Torque bolts 37 to 41 ft. lbs. [50,2 - 55,6 N.m.]

REASSEMBLY OF OUTPUT SHAFT

Assembly of output shaft is optional. In the following illustrations the threaded end of the output shaft is to the rear and is flanged, with the mechanical disconnect to the front.

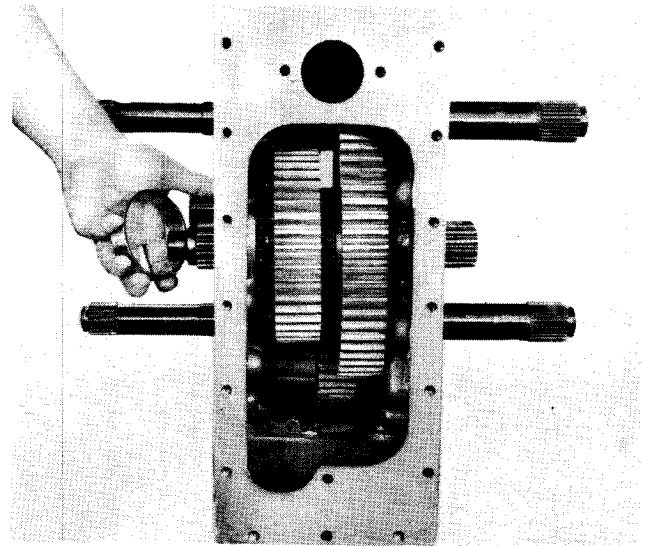


Figure 78

Press taper bearing, (large diameter of taper inward), over threaded end of output shaft against shoulder on shaft. Position small output shaft gear in transmission case to the rear. Position large output shaft gear in transmission case to the front with longer offset of gear hub toward front. Insert output shaft through rear bore of case and through large and small output gears. Figure 78 shows proper stack up of gears. Drive front taper bearing, (large diameter of taper inward), on output shaft until bearing shoulders against small gear.

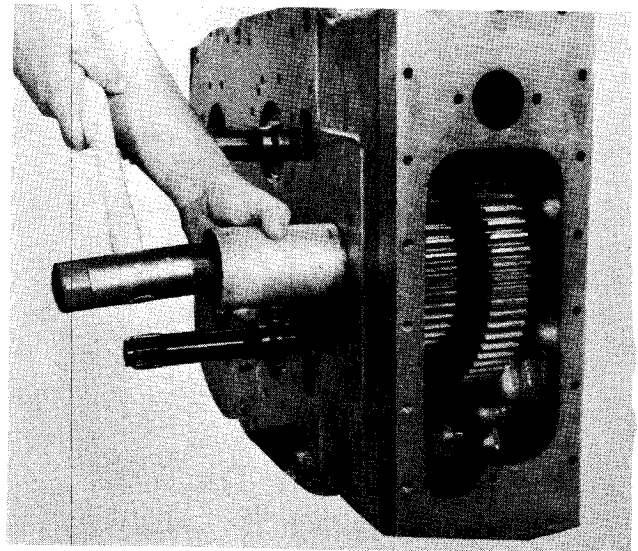


Figure 79

Install rear bearing cup on output shaft.

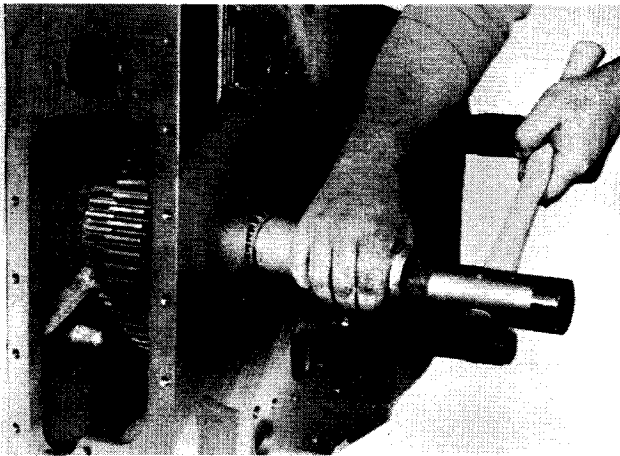


Figure 80

Install front taper bearing on output shaft.

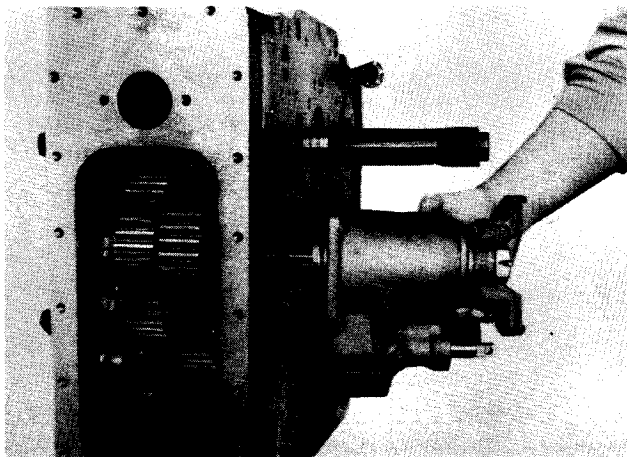


Figure 81

With new "O" ring in position install disconnect assembly on transmission case.

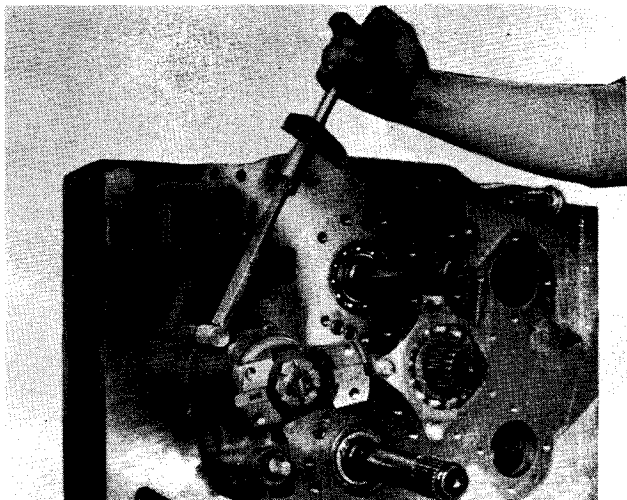


Figure 82

Install disconnect bolts and lockwashers and tighten 35 to 45 ft. lbs. torque. [4,8 - 6,2 m.kg].

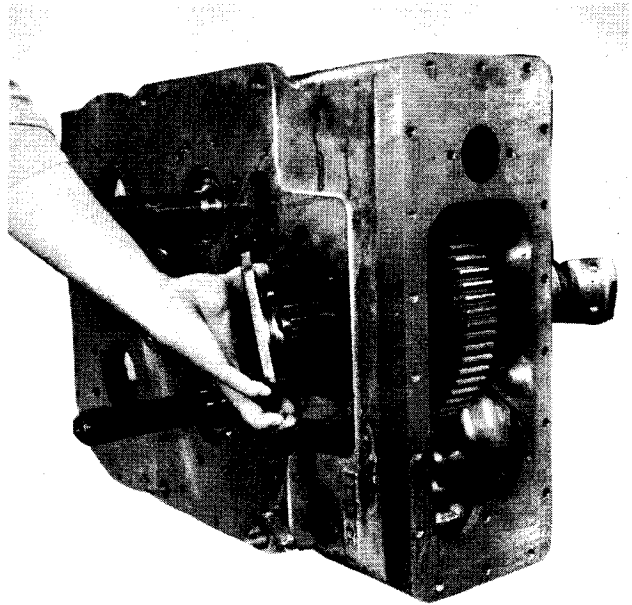


Figure 83

Apply a thin coat of Permatex No. 2 on the outer diameter of the output shaft oil seal. Press oil seal, lip of seal inward, into output shaft bearing cap.

Install a new "O" ring on output shaft bearing cap, lubricate ring with automatic transmission fluid. Install bearing cap and shims, do not tighten bearing cap bolts. Disengage disconnect shaft from output shaft.

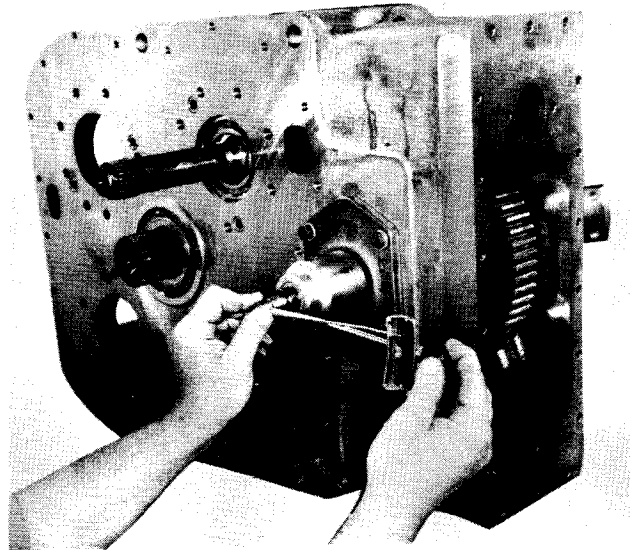


Figure 84

Using an inch pound torque wrench on the disconnect flange nut, determine the amount of torque required to turn gear train.

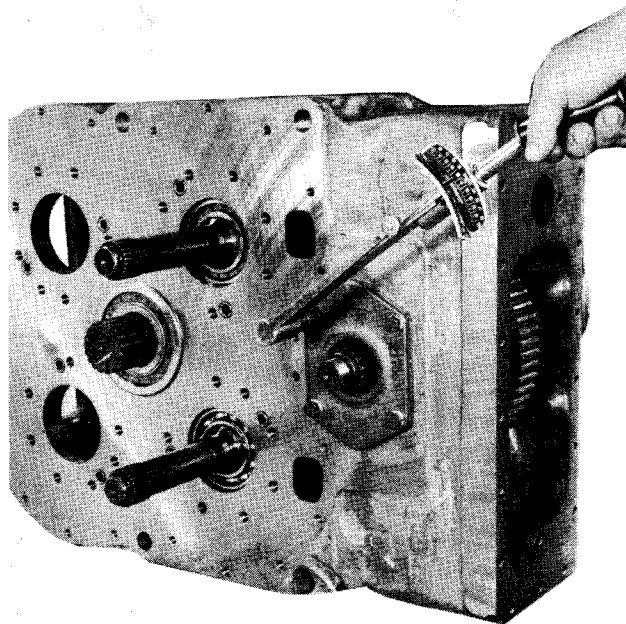


Figure 85

Tighten output shaft bearing cap bolts 35 to 45 ft. lbs. torque. [4,8 - 6,2 m.kg].

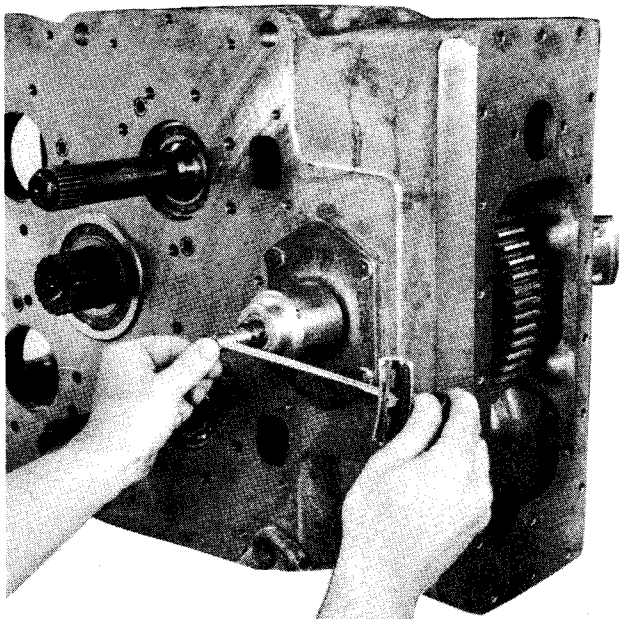


Figure 86

Add or remove shims from bearing cap to adjust preload. When bearings are adjusted properly, it will take 6 to 8 inch pounds [0,07 - 0,09 m.kg] more torque to turn gear train with cap bolts torqued than when bolts were loose.

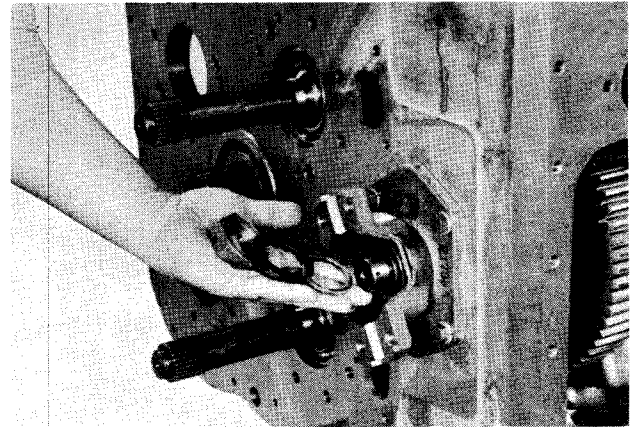


Figure 87

Install output shaft companion flange, flange "O" ring, washer and nut.

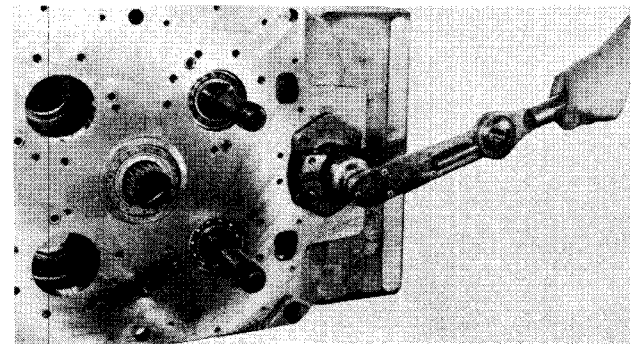


Figure 88

Lock gears with a soft bar and tighten flange nut 175 to 200 ft. lbs. torque [24,2 - 27,6 m.kg]

REASSEMBLY OF REVERSE & INPUT SHAFT

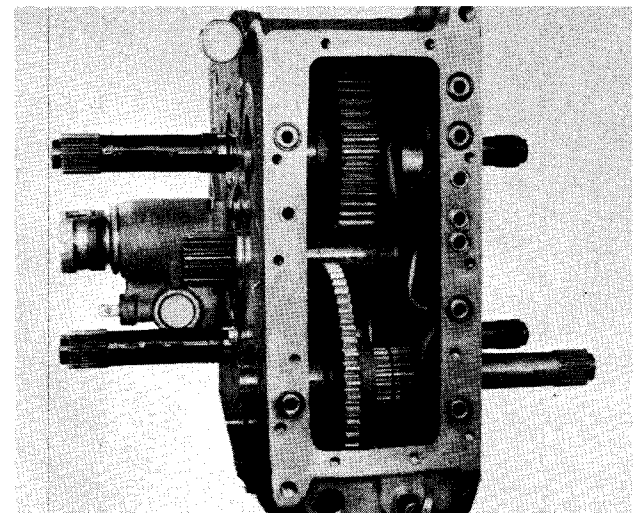


Figure 89

Install reverse shaft into transmission and through reverse gear (hub of gear toward rear of case).

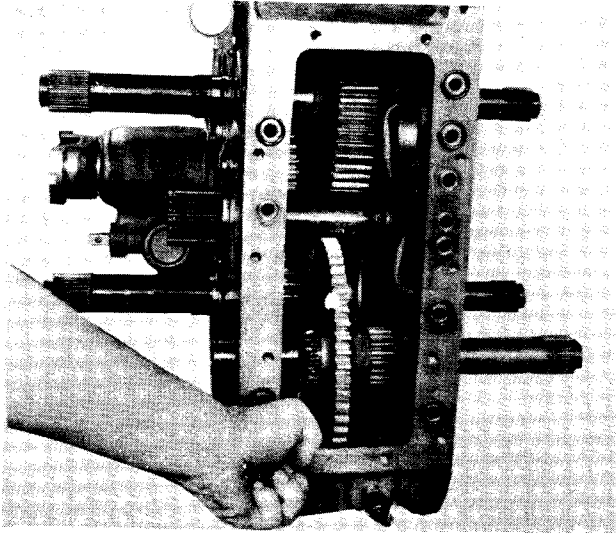


Figure 90
Install reverse gear retainer ring.

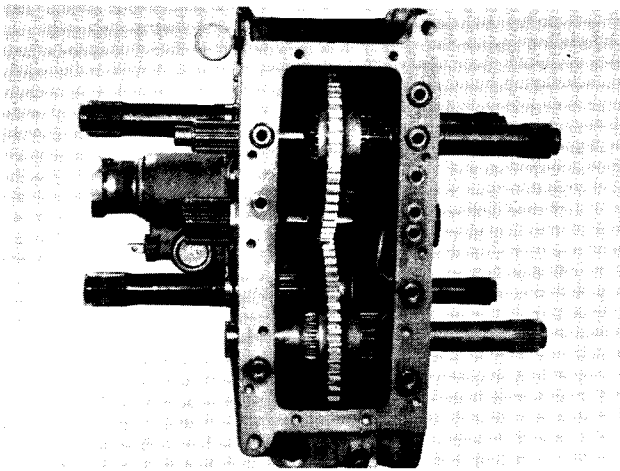


Figure 91
Install input shaft into transmission and through input gear (hub of gear toward rear of case).

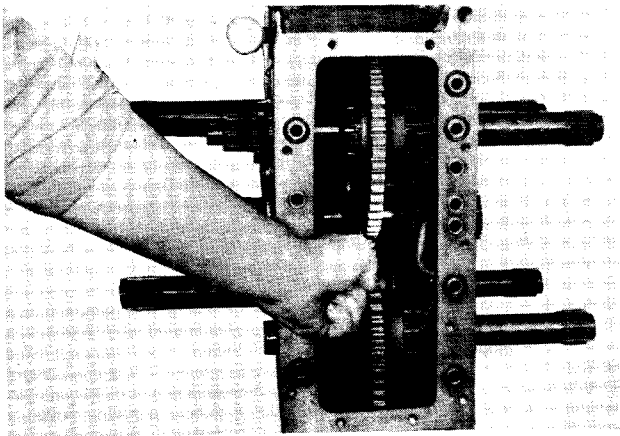


Figure 92
Install input gear retainer ring. Block shaft on rear of case and drive front bearing in position.

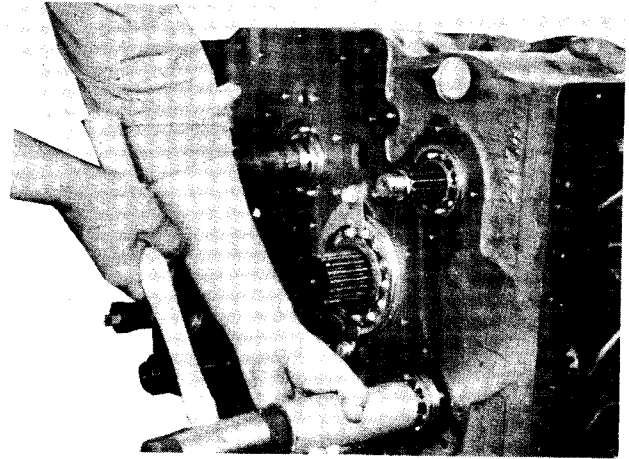


Figure 93
Block reverse shaft on rear of case and drive front bearing in position.

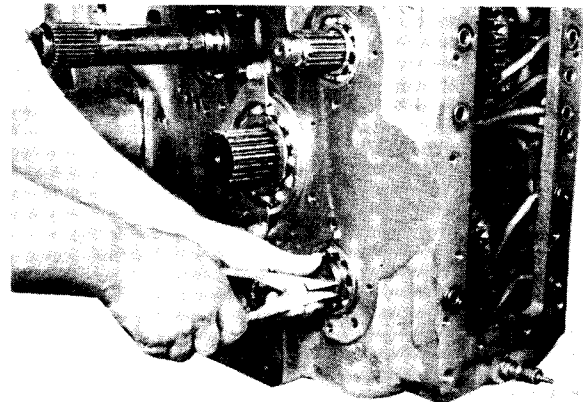


Figure 94
Ins all reverse shaft front bearing retainer ring.

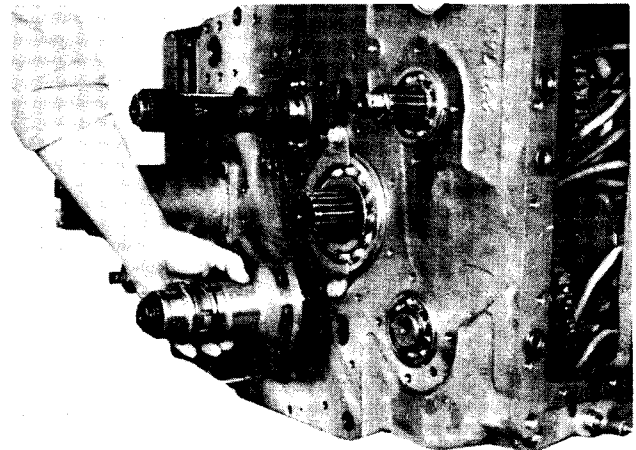


Figure 95
Install 1st and 2nd clutch supports.

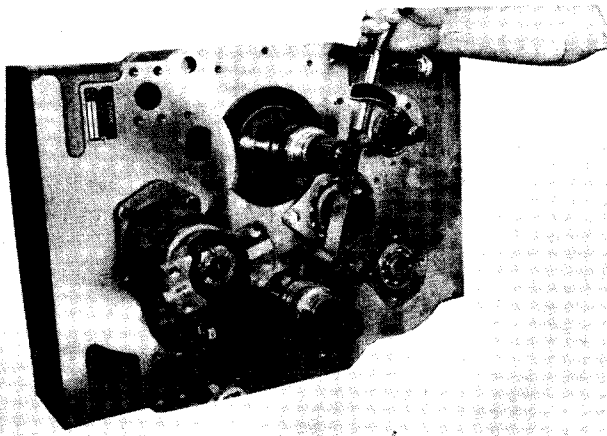


Figure 96

Align holes in clutch supports with holes in transmission case and install self locking bolts. Tighten bolts 80 to 88 ft. lbs. torque [11,1 - 12,1 m.kg].

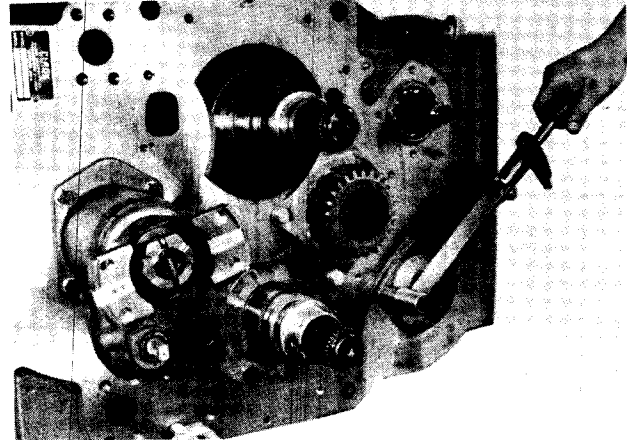


Figure 99

Install bearing cap bolts and tighten 20 to 25 ft. lbs. torque [2,8 - 3,4 m.kg].

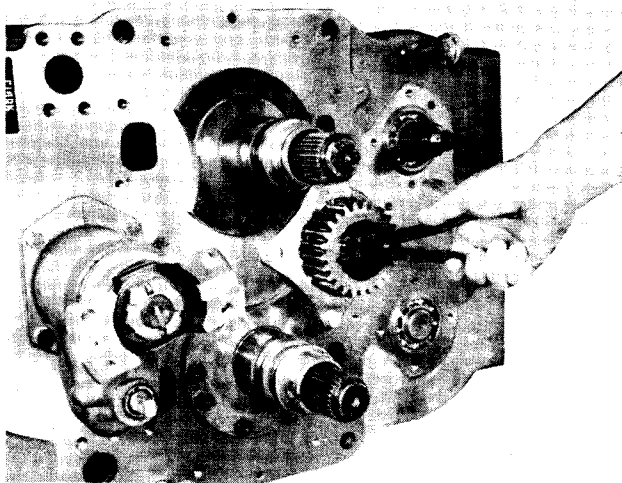


Figure 97

Install idler gear and retainer ring.

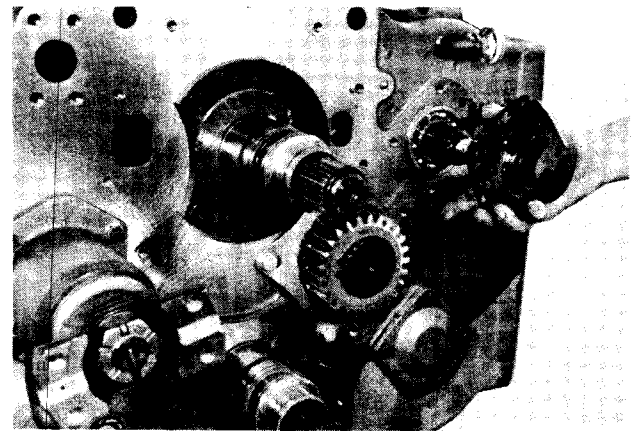


Figure 100

Apply a thin coat of Permatex No. 2 on the outer diameter of the input shaft oil seal. With lip of seal inward, press oil seal in bearing cap 5/16" [7,92 mm] below face of cap. Install new gasket and cap on input shaft.

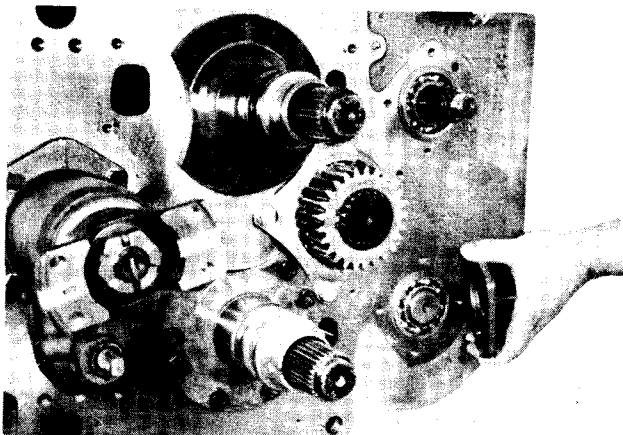


Figure 98

Install new gasket on reverse shaft bearing cap. Position cap over bearing.

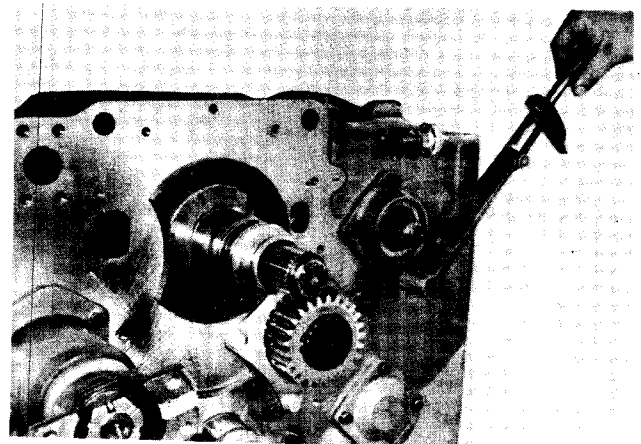


Figure 101

Install bearing cap bolts and tighten 20 to 25 ft. lbs. torque [2,8 - 3,4 m.kg].

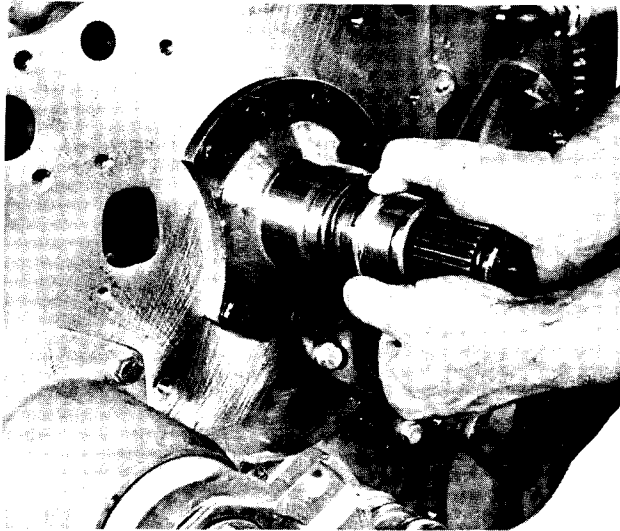


Figure 102

Install new clutch support piston rings. Lock rings in position. Lubricate piston rings with automatic transmission fluid.

REASSEMBLY OF CLUTCHES

NOTE: All clutches are assembled in a similar manner. The quantity of clutch discs will differ between the 1st and 2nd clutch and the forward, reverse, 3rd, and 4th. Do not mix 1st and 2nd clutch plates with forward, reverse, 3rd, and 4th.

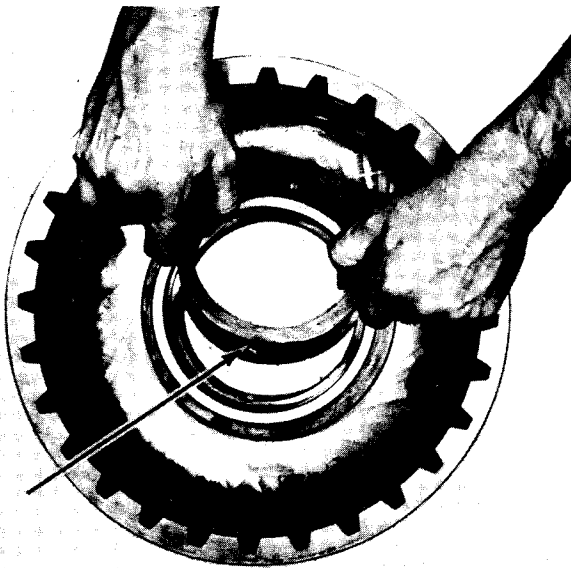


Figure 103

Insert lock ball in clutch piston ring outer race. Press outer race and ball in clutch drum. Outer race must be pressed from flush to 1/64" [0,41mm] below shoulder in clutch drum.

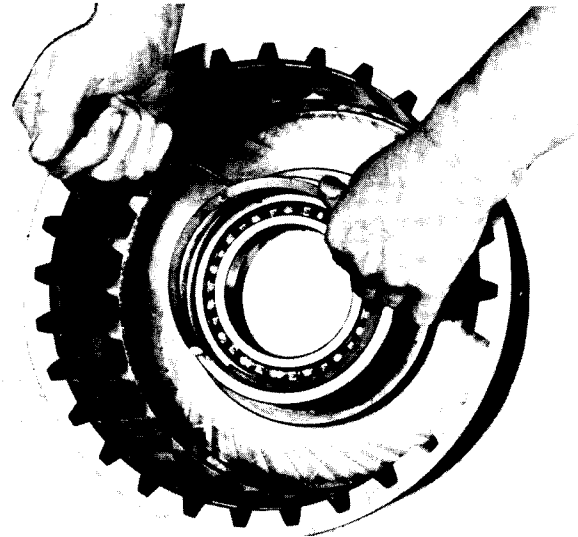


Figure 104

Press support ball bearing in clutch drum, and secure with bearing retainer ring.

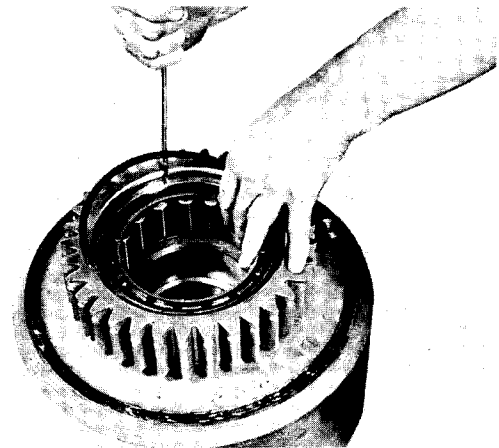


Figure 105

From rear end of clutch drum, press support roller bearing in drum, secure with retainer ring.

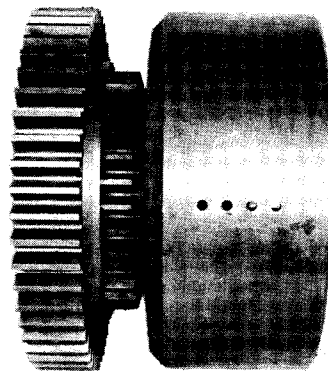


Figure 106

Press clutch drum hub gear on clutch drum with longer offset of gear hub inward. **NOTE:** clutch drum hub gear is used only on the 1st and 2nd clutch.

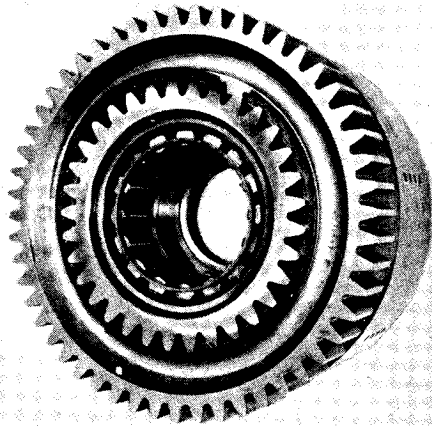


Figure 107

Secure clutch drum hub gear with retainer ring.

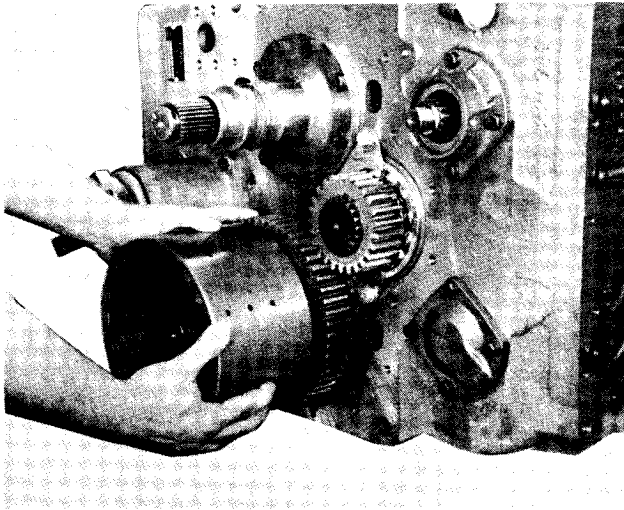


Figure 108

Install clutch drum assembly on clutch support. **CAUTION:** Do not damage clutch support piston rings.

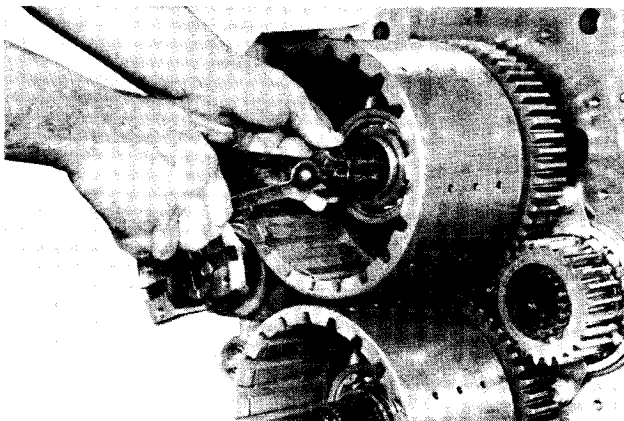


Figure 109

Install clutch drum hub washer and retainer ring.

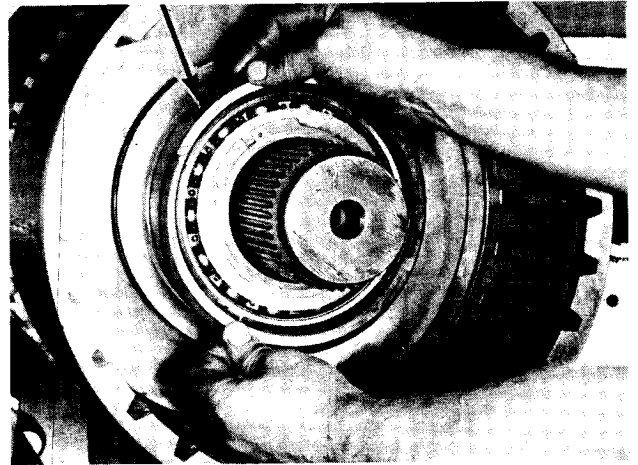


Figure 110

Install clutch piston inner sealing ring. Lubricate piston ring with automatic transmission fluid.

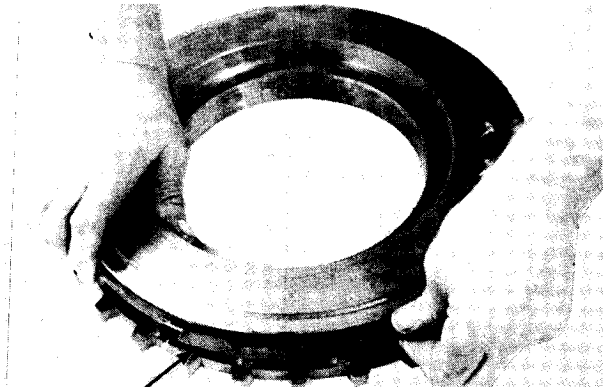


Figure 111

Install clutch piston outer piston ring. Lubricate piston ring with automatic transmission fluid.

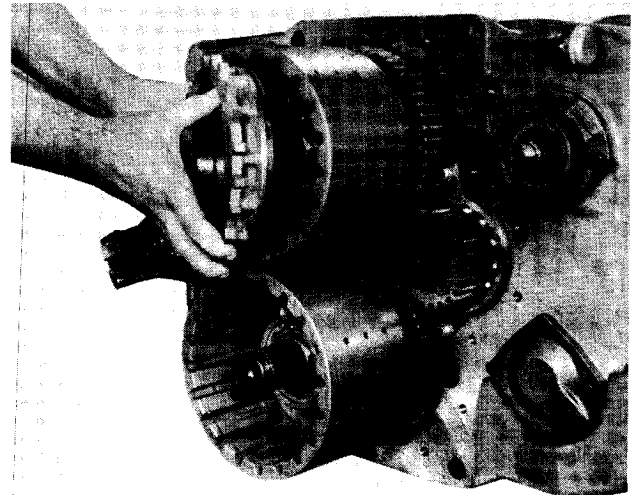


Figure 112

Slide clutch piston into position in clutch drum. **CAUTION:** Do not damage inner and outer piston rings.

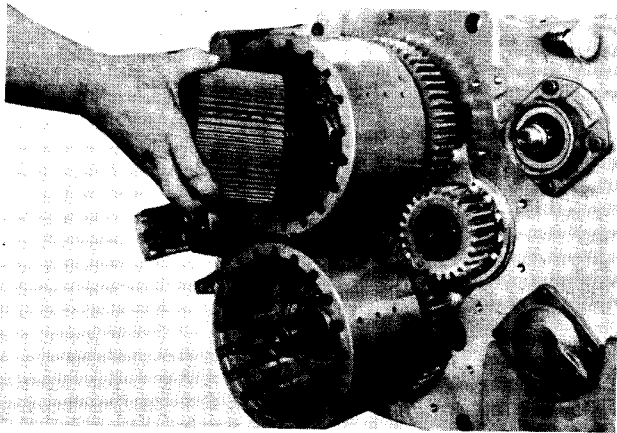


Figure 113

Install clutch disc hub in clutch drum.

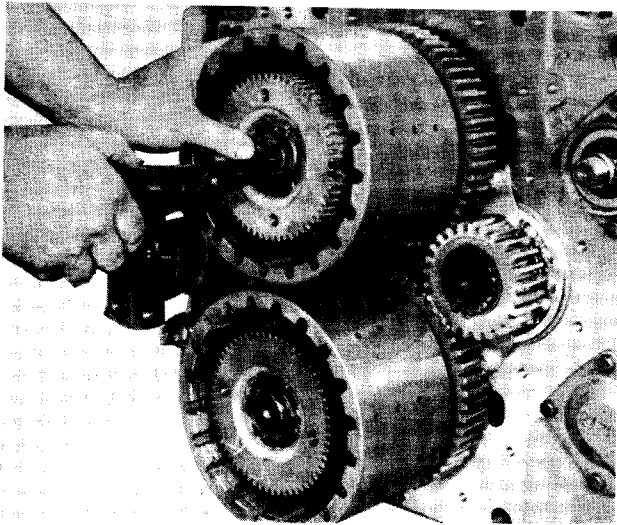


Figure 114

Install disc hub retainer ring.

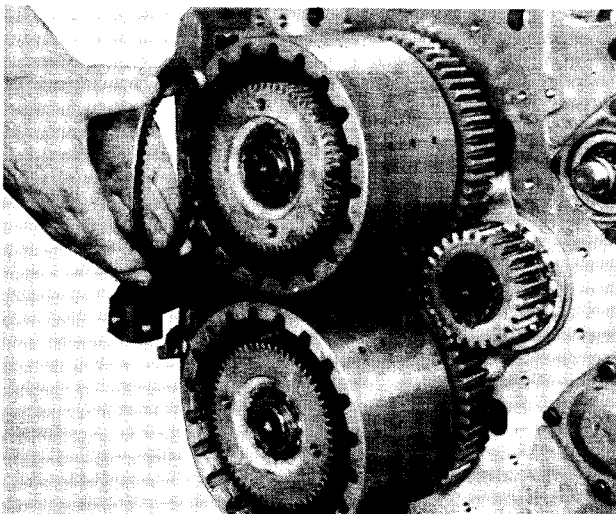


Figure 115

Install one friction disc on disc hub and against the clutch piston.

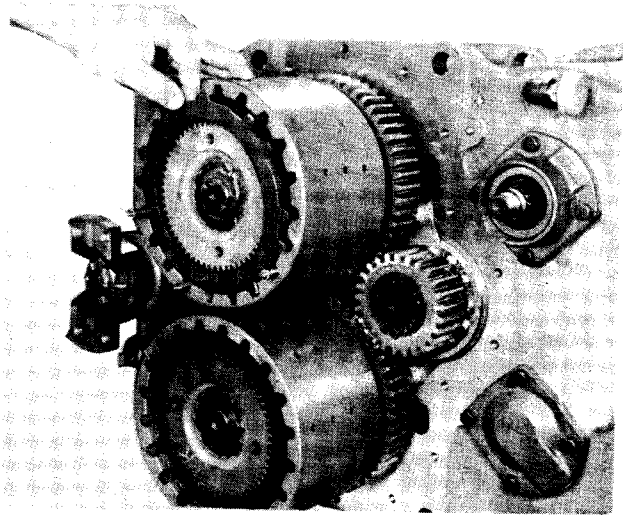


Figure 116

Install one steel disc in clutch drum. **NOTE:** The steel disc has teeth missing on the outer diameter. This is to allow passage for the clutch release springs. Insert two or more release springs in drum and against the teeth of the clutch piston. Install next friction disc. Alternate clutch discs, steel against friction and always align the teeth on each steel disc with the teeth on the preceding steel disc. If assembly is correct each release spring is against a tooth on the clutch piston and you start with a friction disc and end with a friction disc. Insert all release springs and guide pins in clutch drum.

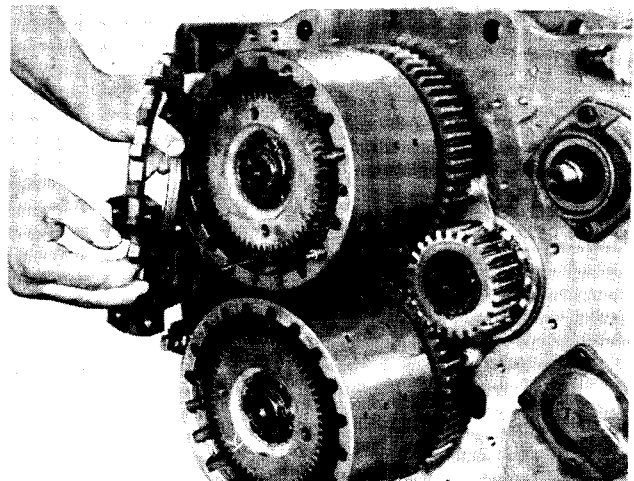
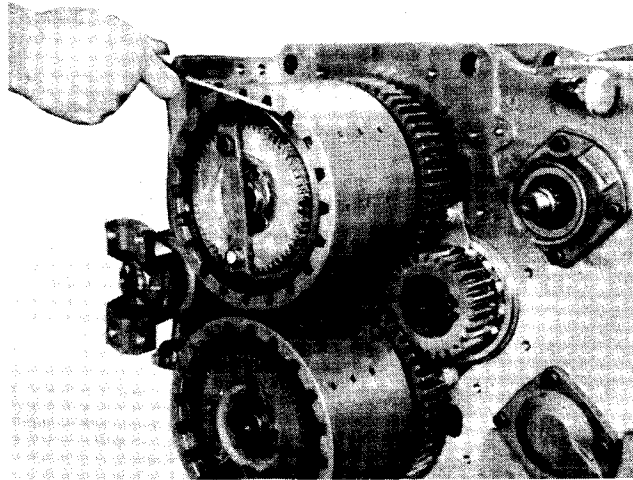


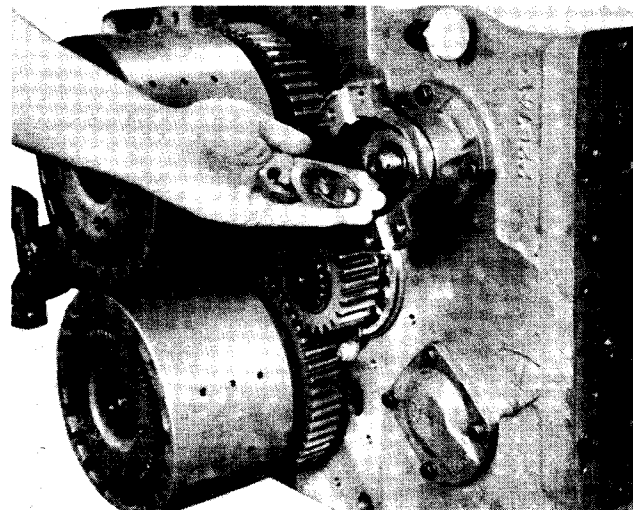
Figure 117

Install clutch disc end plate.

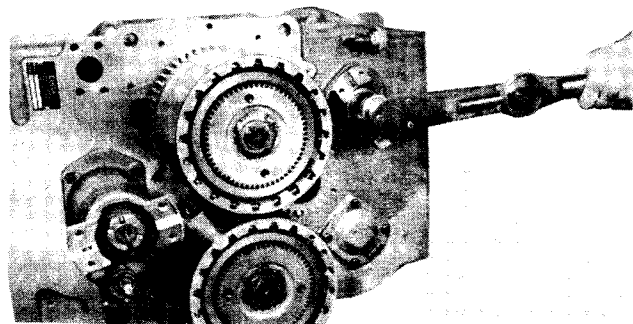
**Figure 118**

Compress clutch disc end plate and install end plate retainer ring.

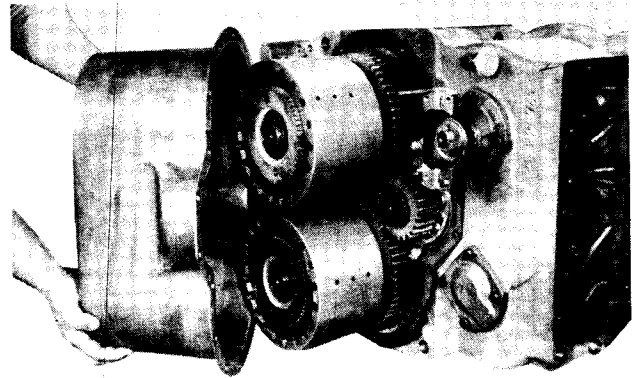
Use the same procedure to assemble all the clutches.

**Figure 119**

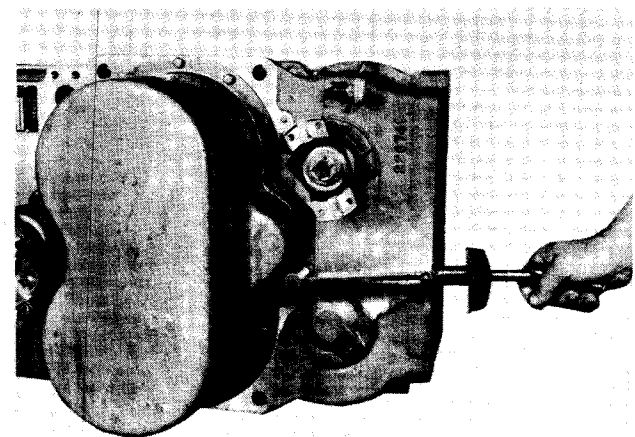
Install input flange, flange "O" ring, flange washer and flange nut.

**Figure 120**

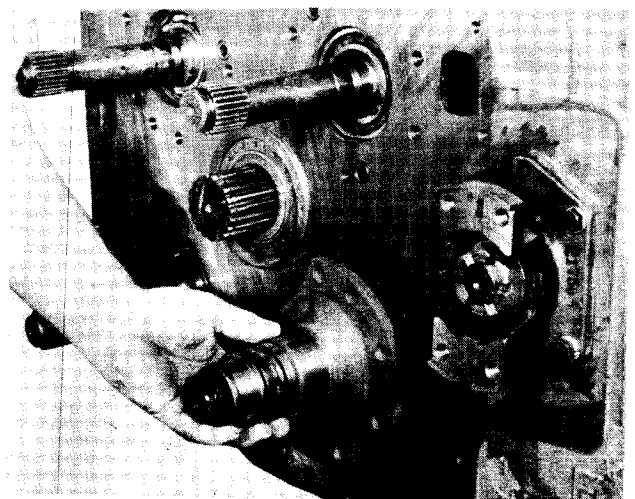
Lock gears with a soft bar and tighten input flange nut 200 to 250 ft. lbs. torque [271,2 - 338,9 N.m.]

**Figure 121**

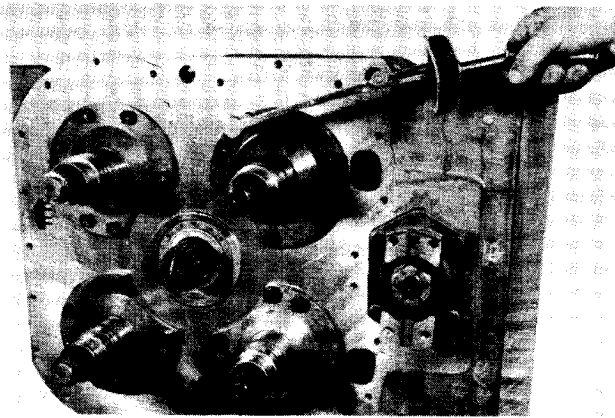
With new gasket in position, install 1st and 2nd clutch cover.

**Figure 122**

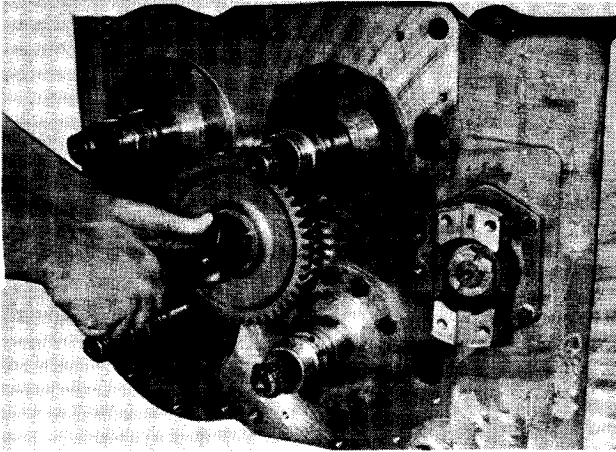
Install clutch cover bolts and tighten 17 to 20 ft. lbs. torque [23,1 - 27,1 N.m.]

**Figure 123**

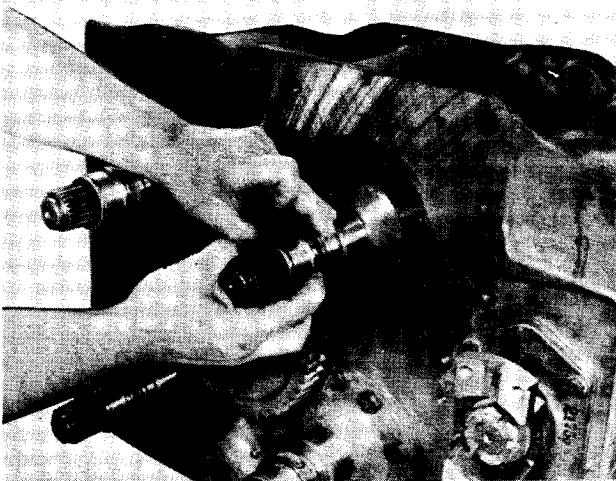
Install input, reverse, 3rd and 4th clutch supports.

**Figure 124**

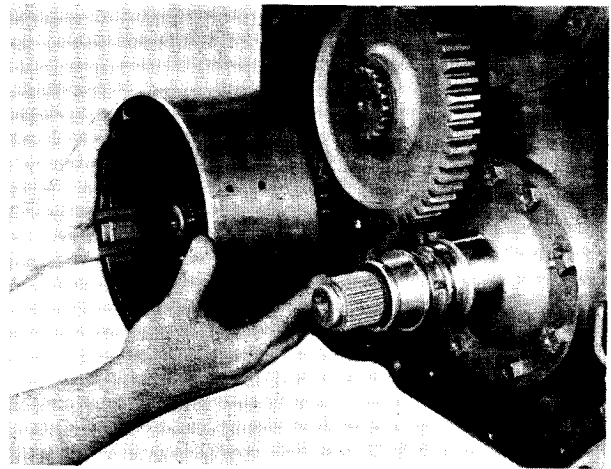
Align holes in clutch supports with holes in transmission case and install self-locking bolts. Tighten bolts 80 to 88 ft. lbs. torque [11,1 - 12,1 m.kg].

**Figure 125**

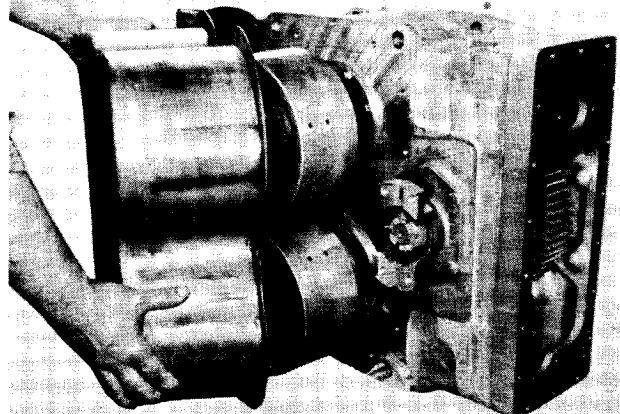
Install large idler gear and retainer ring.

**Figure 126**

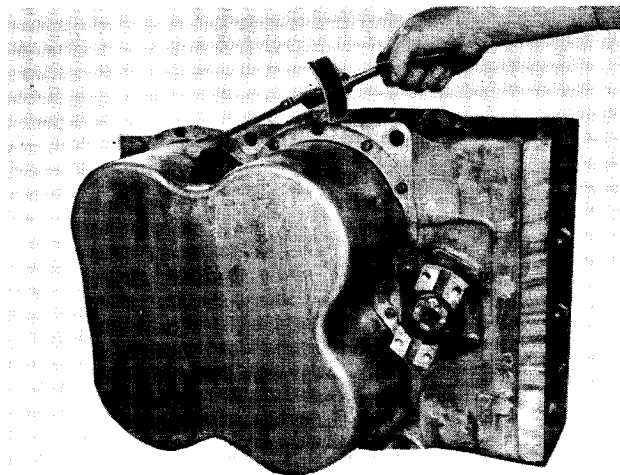
Install new clutch support piston rings. Lock rings in position. Lubricate piston rings with automatic transmission fluid.

**Figure 127**

Install input, reverse, 3rd and 4th clutches as explained in Figures 103 thru 105 and 108 thru 118.

**Figure 128**

With new gasket in position, install input, reverse, 3rd and 4th clutch cover.

**Figure 129**

Install clutch cover bolts and tighten 20 to 25 ft. lbs. torque [2,8 - 3,4 m.kg].

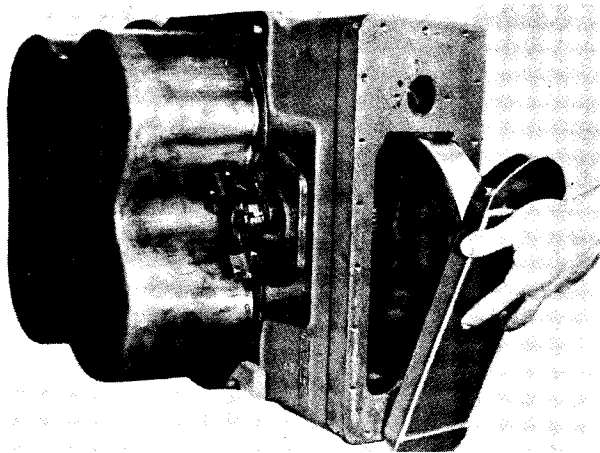


Figure 130

Install sump screen and baffle assembly, secure with bolts and lockwashers. Tighten 20 to 25 ft. lbs. torque [2,8 - 3,4 m.kg].

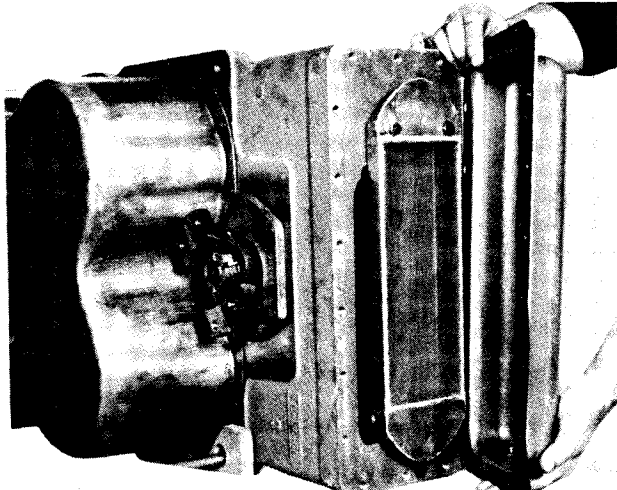


Figure 131

Install new gasket on transmission sump pan. Set pan magnets over welded washers in sump pan.

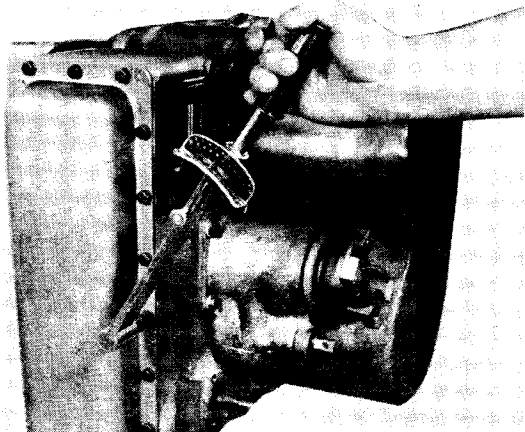


Figure 132

Install sump pan bolts and tighten 20 to 25 ft. lbs. torque [2,8 - 3,4 m.kg].

REASSEMBLY OF CONTROL COVER

See figure "C" for sequence of parts and parts identification. **NOTE:** Lubricate all valves, springs, "O" rings, sleeves and oil seals with a light coat of automatic transmission fluid.

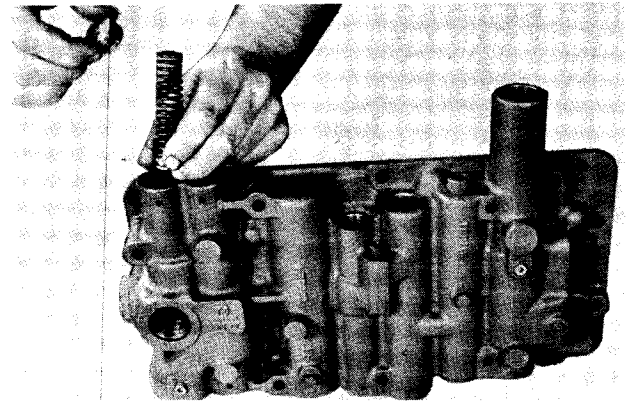


Figure 133

Install safety valve ball and spring in cover. With new "O" ring in position install spring stop on spring.

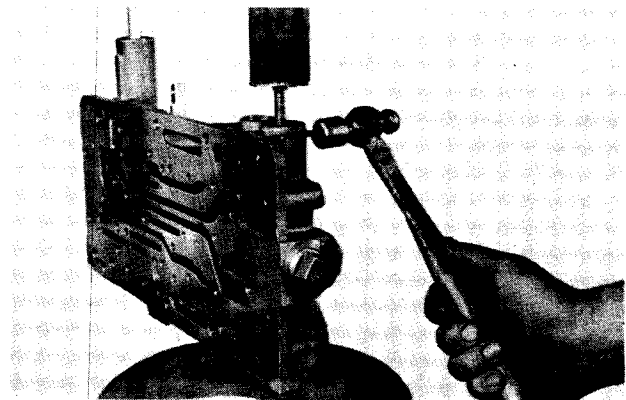


Figure 134

Depress spring stop and spring. Install spring stop roll pin.

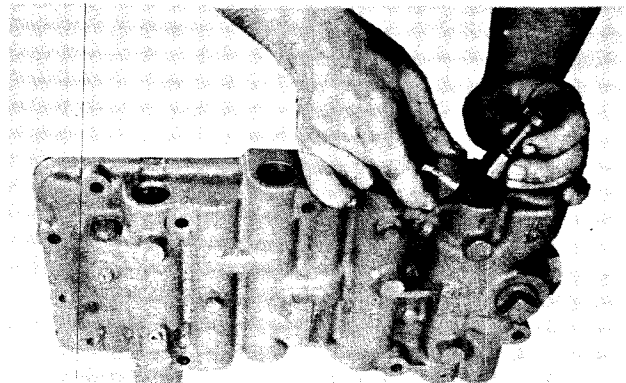


Figure 135

Install regulating valve spool in valve cover. Install new "O" ring on valve stop. Install valve stop in cover and retain with roll pin.

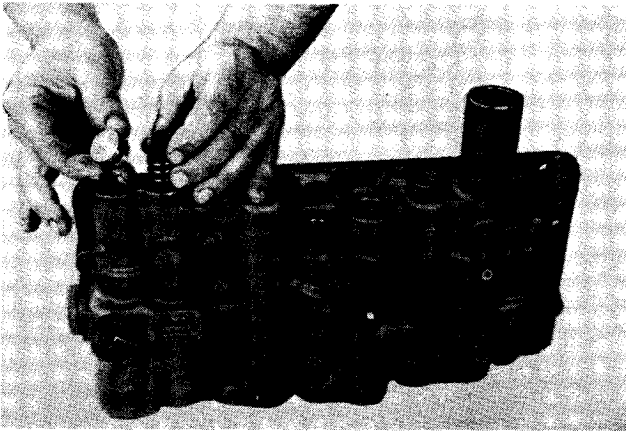


Figure 136

At opposite end of regulating valve install inner and outer valve spring. Install new "Q" ring on spring stop. Install spring stop on springs.



Figure 139

Install shut-off valve in housing. Depress valve and spring with valve plug. Tighten plug securely.

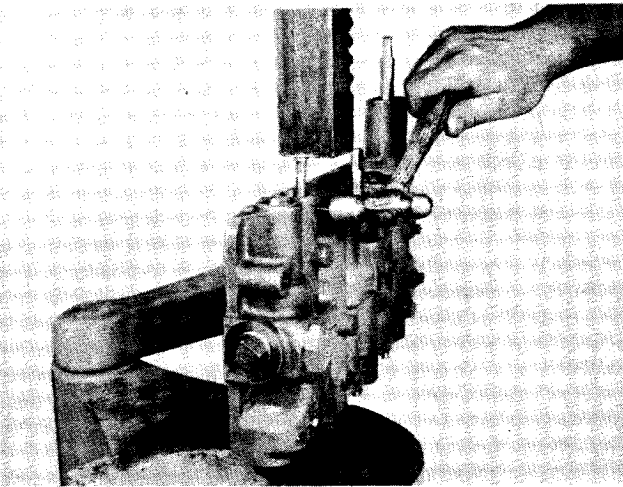


Figure 137

Depress spring stop and spring. Install spring stop roll pin.

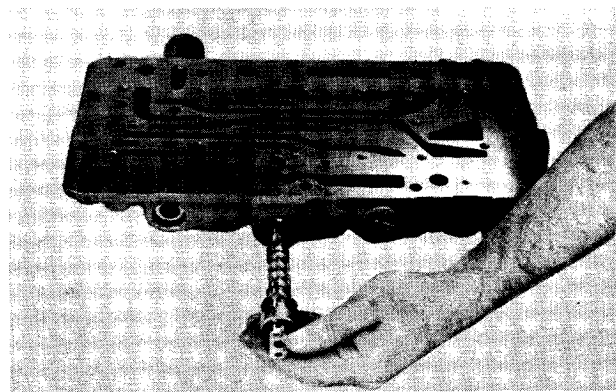


Figure 140

Install forward and reverse selector valve in housing. Install selector valve stop washer and oil seal on selector valve.

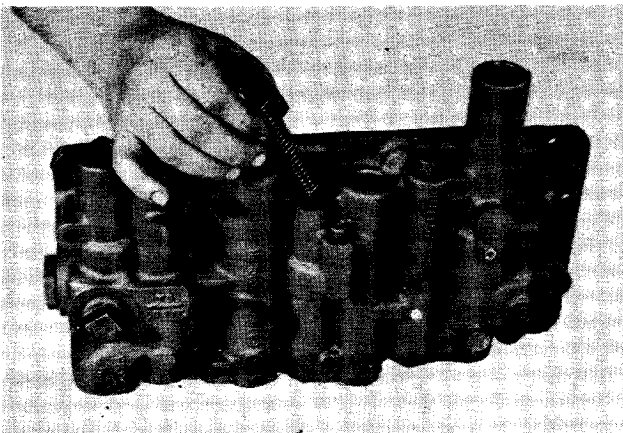


Figure 138

Install shut-off valve spring.

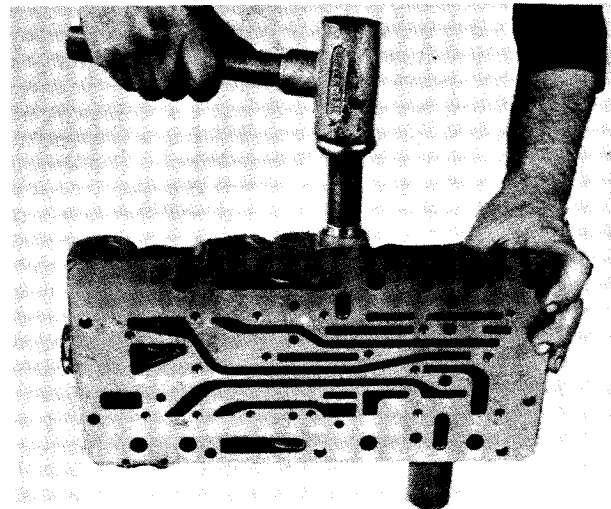


Figure 141

Apply a light coat of Permatex No. 2 on the outer diameter of a new selector valve oil seal. Install oil seal in housing.

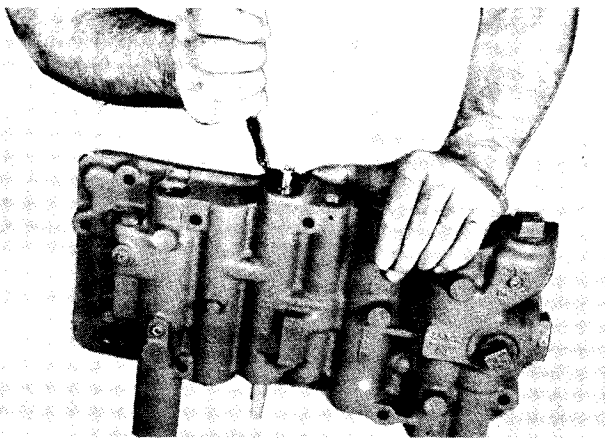


Figure 142

Install oil seal retainer ring.

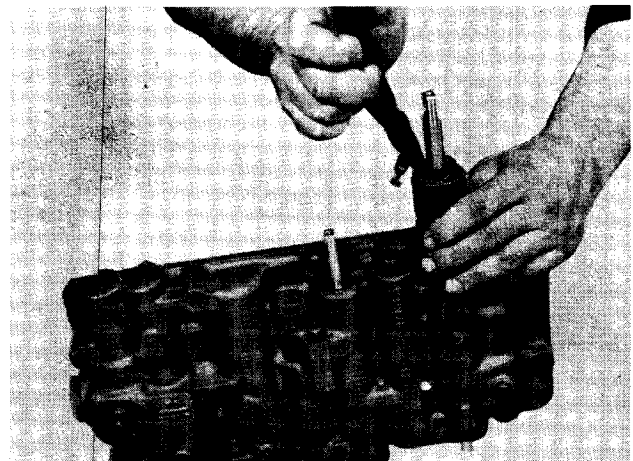


Figure 145

Install oil seal retainer ring.

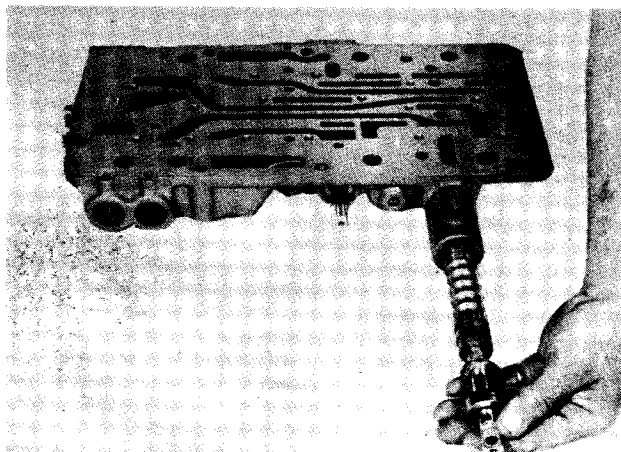


Figure 143

Install speed selector valve in housing. Install selector valve stop washer and oil seal on selector valve.

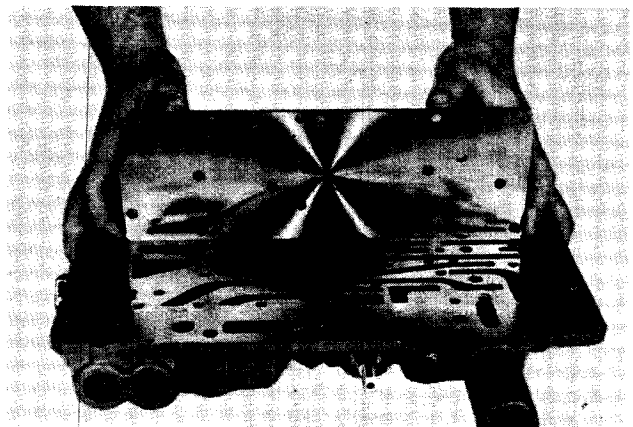


Figure 146

Install poppet balls and poppet springs in drilled ports in control cover. Install control cover plate. Secure with bolts and external shake proof washers. Tighten 10 to 15 ft. lbs. torque [1,4 - 2,0 m.kg].

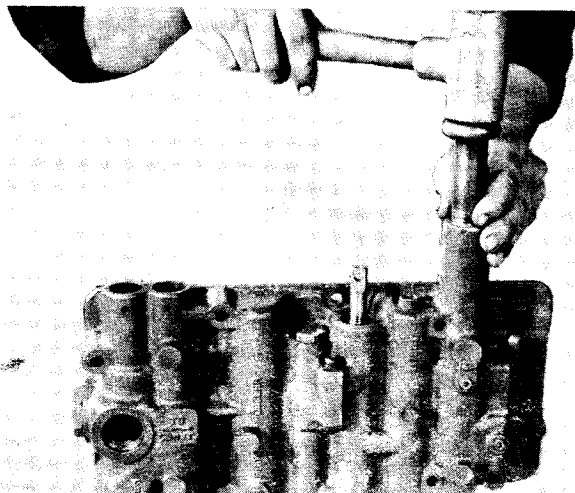


Figure 144

Apply a light coat of Permatex No. 2 on the outer diameter of a new selector valve oil seal. Install oil seal in housing.

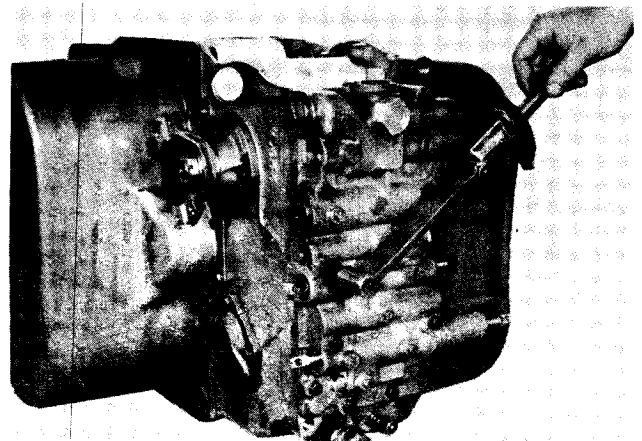


Figure 147

Using new control valve to case "O" rings and new gasket, install control cover assembly on transmission case. Secure with bolts and lockwashers. Tighten 20 to 25 ft. lbs. torque [2,8 - 3,4 m.kg]

SERVICING MACHINE AFTER TRANSMISSION OVERHAUL

The transmission, torque converter, and its allied hydraulic system are important links in the drive line between the engine and the wheels. The proper operation of either unit depends greatly on the condition and operation of the other; therefore, whenever repair or overhaul of one unit is performed, the balance of the system must be considered before the job can be considered completed.

After the overhauled or repaired transmission has been installed in the machine, the oil cooler, and connecting hydraulic system must be thoroughly cleaned. This can be accomplished in several manners and a degree of judgment must be exercised as to the method employed.

The following are considered the minimum steps to be taken:

1. Drain entire system thoroughly.
2. Disconnect and clean all hydraulic lines. Where feasible, hydraulic lines should be removed from machine for cleaning.
3. Replace oil filter elements, cleaning out filter cases thoroughly.
4. The oil cooler must be thoroughly cleaned. The cooler should be "back flushed" with oil and compressed air until all foreign material has been removed. Flushing in direction of normal oil flow will not adequately clean the cooler. If necessary, cooler assembly should be removed from machine for cleaning, using oil, compressed air and steam cleaner for that purpose. **DO NOT** use flushing compounds for cleaning purposes.

5. On remote mounted torque converters remove drain plug from torque converter and inspect interior of converter housing, gears, etc. If presence of considerable foreign material is noted, it will be necessary that converter be removed, disassembled and cleaned thoroughly. It is realized this entails extra labor; however, such labor is a minor cost compared to cost of difficulties which can result from presence of such foreign material in the system.
6. Reassemble all components and use only type oil recommended in lubrication section. Fill transmission through filler opening until fluid comes up to **LOW** mark on transmission dipstick. **NOTE:** If the dipstick is not accessible oil level check plugs are provided.

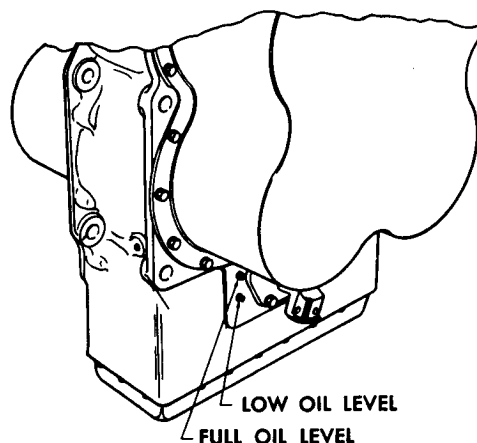
Remove **LOWER** check plug, fill until oil runs from **LOWER** oil hole. Replace filler and level plug.

Run engine two minutes at 500-600 RPM to prime torque converter and hydraulic lines. Recheck level of fluid in transmission with engine running at idle (500-600 RPM).

Add quantity necessary to bring fluid level to **LOW** mark on dipstick or runs freely from **LOWER** oil level check plug hole. Install oil level plug or dipstick. Recheck with hot oil (180-200° F.) [82, 2-93, 3° C].

Bring oil level to **FULL** mark on dipstick or runs freely from **UPPER** oil level plug.

7. Recheck all drain plugs, lines, connections, etc., for leaks and tighten where necessary.



SPECIFICATIONS AND SERVICE DATA—POWER SHIFT TRANSMISSION AND TORQUE CONVERTER

CONVERTER OUT PRESSURE	Converter outlet oil temp. 180°-200° F. [82,3°-93,3° C]. Transmission in NEUTRAL . Operating specifications: 55 P.S.I. [3,9 KG/cm ²] minimum pressure at 2000 R.P.M. engine speed AND a maximum of 70 P.S.I. [4,92 KG/cm ²] outlet pressure with engine operating at no-load governed speed.
CONTROLS	Forward and Reverse — Manual Speed Selection — Manual
CLUTCH TYPE	Multiple discs, hydraulically actuated, spring released, automatic wear compensation and no adjustment. All clutches oil cooled and lubricated.
CLUTCH INNER DISC	Friction.
CLUTCH OUTER DISC	Steel

OIL FILTRATION Full flow oil filter safety by-pass, also strainer screen in sump at bottom of transmission case.

CLUTCH PRESSURE 180-220 p.s.i. [12,7-15,4 kg/cm²] — With parking brake set (see note), oil temperature 180 - 200° F. [82,2-93,3° C], engine at idle (400 to 600 RPM), shift thru direction and speed clutches. **All clutch pressure must be equal within 5 psi. [0,4 kg/cm²]. If clutch pressure varies in any one clutch more than 5 psi. [0,4 kg/cm²] repair clutch.**

NOTE: Never use service brakes while making clutch pressure checks. Units having brake actuated declutching in forward and/or reverse will not give a true reading.

ALWAYS USE PARKING BRAKE WHEN MAKING CLUTCH PRESSURE CHECKS.

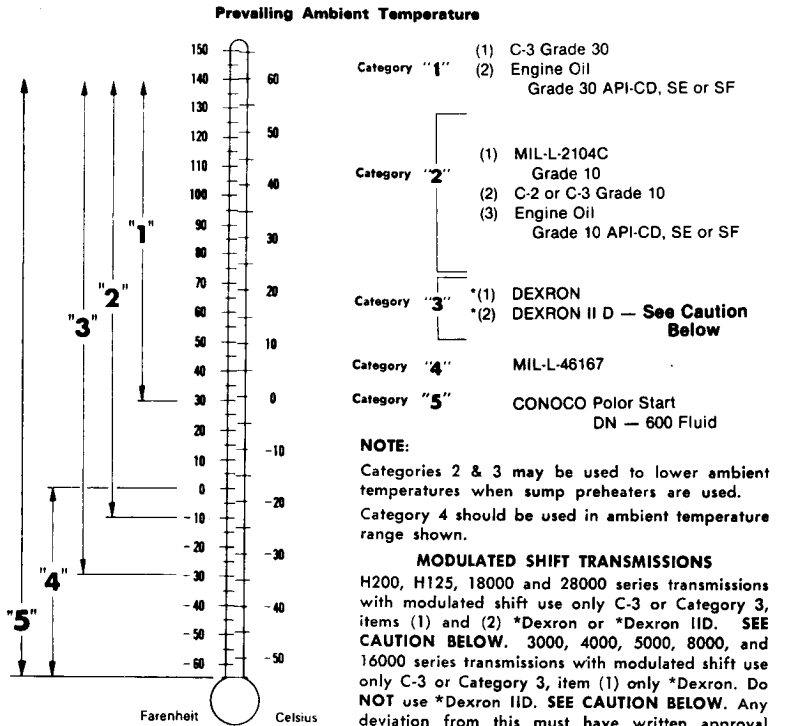
LUBRICATION

TYPE OF OIL	See Lube Chart.
CAPACITY	Consult Operator's Manual on applicable machine model for system capacity. Torque Converter, Transmission and allied hydraulic system must be considered as a whole to determine capacity.
CHECK PERIOD	Check oil level DAILY with engine running at 500-600 RPM and oil at 180° to 200° F. [82, 2 - 93, 3° C]. Maintain oil level to FULL mark.
NORMAL * DRAIN PERIOD	Every 500 hours, change oil filter element. Every 1000 hours, drain and refill system as follows: Drain with oil at 150° to 200° F. [65, 6 - 93, 3° C].

NOTE: It is recommended that filter elements be changed after 50 and 100 hours of operation on new and rebuilt or repaired units.

- (a) Drain transmission and remove sump screen. Clean screen thoroughly and replace, using new gaskets.
- (b) Drain oil filters, remove and discard filter elements. Clean filter shells and install new elements.
- (c) Refill transmission to **LOW** mark.
- (d) Run engine at 500-600 RPM to prime converter and lines.
- (e) Recheck level with engine running at 500 - 600 RPM and add oil to bring level to **LOW** mark. When oil temperature is hot (180-200° F.) [82,2-93,3° C] make final oil level check. **BRING OIL LEVEL TO FULL MARK.**

RECOMMENDED LUBRICANTS FOR CLARK POWER SHIFTED TRANSMISSION AND TORQUE CONVERTERS



NOTE: Categories 2 & 3 may be used to lower ambient temperatures when sump preheaters are used. Category 4 should be used in ambient temperature range shown.

MODULATED SHIFT TRANSMISSIONS
H200, H125, 18000 and 28000 series transmissions with modulated shift use only C-3 or Category 3, items (1) and (2) *Dexron or *Dexron IID. **SEE CAUTION BELOW.** 3000, 4000, 5000, 8000, and 16000 series transmissions with modulated shift use only C-3 or Category 3, item (1) only *Dexron. Do **NOT** use *Dexron IID. **SEE CAUTION BELOW.** Any deviation from this must have written approval from Clark Engineering at Jackson, Michigan.

CAUTION: *Dexron II D is not compatible with graphitic clutch plate friction material. *Dexron II D cannot be used in the 3000, 4000, 5000, 8000 or 16000 series power shift transmissions, or the HR28000 series having converter lock-up, or the C270 series converter having lock-up.

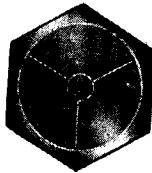
*Dexron is a registered trademark of General Motors Corporation.

***Normal drain periods and filter change intervals are for average environmental and duty-cycle conditions. Severe or sustained high operating temperatures or very dusty atmospheric conditions will cause accelerated deterioration and contamination. For extreme conditions judgment must be used to determine the required change intervals.**

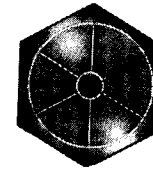
TORQUE IN (FT.—LBS.) BOLTS, CAPSCREWS, STUDS AND NUTS

Grade 5 Identification, 3 Radial
Dashes 120° Apart on Head of Bolt

Grade 8 Identification, 6 Radial
Dashes 60° Apart on Head of Bolt



Grade 5



Grade 8

LUBRICATED OR PLATED

Nominal Thread Size	FINE THREADS		COARSE THREADS	
3/8	26-29 [3,6-4,0m.kg]	23-25 [3,2-3,4m.kg]	37-41 [5,1-5,6m.kg]	33-36 [4,6-4,9m.kg]
7/16	41-45 [5,7-6,2m.kg]	37-41 [5,1-5,6m.kg]	58-64 [8,0-8,8m.kg]	52-57 [7,2-7,8m.kg]
1/2	64-70 [8,8-9,6m.kg]	57-63 [7,9-8,7m.kg]	90-99 [12,4-13,6m.kg]	80-88 [11,-12,1m.kg]
9/16	91-100 [12,6-13,8m.kg]	82-90 [11,3-12,4m.kg]	128-141 [17,7-19,4m.kg]	115-127 [15,9-17,5m.kg]

PRESSURE AND OIL FLOW CHECK SPECIFICATIONS. ALL CHECKS MADE WITH HOT OIL (180 - 200° F.) [82,2 - 93,3° C.]

- | | |
|--------------------------------------------------|--------------------------------------------------------------------------------------------------------------------------------------------------------------------|
| A. Clutch Pressure at Transmission Control Cover | 180 - 220 p.s.i. [12,7 - 15,4 kg/cm ²] at engine idle, each clutch and no more than 5 p.s.i. [0,4 kg/cm ²] variation between all clutches. |
| B. Transmission to Converter Line | See External Oil Flow Diagram. |
| C. Converter-Out Pressure | See Pressure and Oil Flow Checks. |
| D. Temperature Gauge Connection | See External Oil Flow Diagram. |
| E. Lubricating Pressure | 25 p.s.i. [1,7 kg/cm ²] Maximum at High Free Idle. |
| Converter Return Line | See External Oil Flow Diagram. |
| Converter Pump Output | See Pump Chart. |

TROUBLE SHOOTING GUIDE

The following data is presented as an aid to locating the source of difficulty in a malfunctioning unit. It is necessary to consider the torque converter charging pump, transmission, oil cooler and connecting oil lines as a complete system when running down the source of trouble since the proper operation of any unit therein depends greatly on the condition and operation of the others. By studying the principles of operation together with data in this section, it may be possible to correct any malfunction which may occur in the system.

TROUBLE SHOOTING PROCEDURE BASICALLY CONSISTS OF TWO CLASSIFICATIONS: MECHANICAL AND HYDRAULIC.

MECHANICAL CHECKS

Prior to checking any part of the system from a hydraulic standpoint, the following mechanical checks should be made.

1. A check should be made to be sure all control lever linkage is properly connected and adjusted at all connecting points.
2. Check shift levers and rods for binding or restrictions in travel that would prevent full engagement. Shift levers by hand at transmission case, if full engagement cannot be obtained, difficulty may be in control cover and valve assembly.

HYDRAULIC CHECKS

Before checking on the torque converter, transmission and allied hydraulic systems for pressures and rate of oil flow, it is essential that the following preliminary checks be made.

1. Check oil level in transmission. This should be done with oil temperatures of 180-200°F. [82,2-93,3°C.]. DO NOT ATTEMPT THESE CHECKS WITH COLD OIL. To bring the oil temperature to this specification it is necessary to either work the machine or "stall" out the converter. Where the former means is impractical, the latter means should be employed as follows:

Engage shift levers in forward and high speed and apply brakes. Accelerate engine half to three-quarter throttle.

Hold stall until desired converter outlet temperature is reached. CAUTION: FULL THROTTLE STALL SPEEDS FOR AN EXCESSIVE LENGTH OF TIME WILL OVERHEAT THE CONVERTER.

PRESSURE AND OIL FLOW CHECKS

Whenever improper performance is evident the following basic pressure and oil flow checks should be performed and recorded. It is also recommended that these checks be taken periodically as a preventative maintenance measure. Doing so will permit possible detection of difficulties in advance of actual breakdown, thus permitting scheduling of repair operation. Likewise, repair of minor difficulties can be made at considerably less cost and down-time than when delayed until major and complete breakdowns occur.

Analyzing the results of these checks by comparison with specifications and with each other will indicate in most cases the basic item or assembly in the system as the source of difficulty. Further checking of that assembly will permit isolation of the specific cause of trouble.

(SEE PLUMBING AND CHECK POINT DIAGRAM)

OIL PRESSURE AT CONVERTER OUT PORT.

Install hydraulic pressure gauge at **PRESSURE** connection on Converter Regulator Valve or at **CONVERTER OUT** pressure tap. (All models do not have pressure regulating valves.) Check and record oil pressure at 2000 RPM and at maximum speed (engine at full throttle) (see instructions on Stalling Converter previously listed).

CONVERTER MODEL		MAXIMUM CONVERTER OUT PRESSURE
C-270.....	25 p.s.i. [1, 7 kg/cm ²]	70 p.s.i. [4, 9 kg/cm ²]
C-5000.....	55 p.s.i. [3, 9 kg/cm ²]	70 p.s.i. [4, 9 kg/cm ²]
C-8000.....	55 p.s.i. [3, 9 kg/cm ²]	70 p.s.i. [4, 9 kg/cm ²]
C-16000.....	55 p.s.i. [3, 9 kg/cm ²]	70 p.s.i. [4, 9 kg/cm ²]

If a flow meter is available, install in line between converter charging pump and oil filters. Flow meter must be able to withstand 300 p.s.i. [21, 0 kg/cm²].

Disconnect hose between pump and filter at filter end and using suitable fittings connect to pressure port of tester. Install hose between filter and tester, connecting same to reservoir port of tester.

DO NOT USE TESTER LOAD VALVE AT ANY TIME DURING TEST. When taking flow reading, all readings should be taken on the first (left) half of flow gauge. Whenever the needle shows on the right half of gauge, correct by switching to higher scale.

If a flow meter is not available for checking converter pump output, proceed with manual transmission and converter checks. If the converter shows leakage within specifications and clutch pressures (180 to 220 p.s.i.) [12, 7 - 15, 4 kg/cm²] are all equal within 5 p.s.i. [0, 4 kg/cm²] refer to paragraph on Low Converter Charging Pump Output.

PUMPS ARE RATED AT 2000 RPM—Refer to Vehicle Manufacture Manual for specific pump output.

NOMINAL PUMP RATINGS:	C-270	C-5000	C-8000	C-16000
	11 G.P.M.	21 G.P.M.	21 G.P.M.	40 G.P.M.
	15 G.P.M.	31 G.P.M.	31 G.P.M.	50 G.P.M.
	21 G.P.M.		40 G.P.M.	65 G.P.M.

Pump output listed applies to a new pump in each case. A 20% tolerance below this figure is permissible; however, if pump output is more than 20% below specification the pump must be replaced and not rebuilt.

TRANSMISSION CLUTCH LEAKAGE

Check clutch pressures at low engine idle with oil at operating temperatures 180 - 200° F. [82, 2 - 93, 3° C]. Engine speed must remain constant during entire leakage check. Shift lever into forward 4 or 8 speeds. Record pressures. Shift lever in reverse and 1st. Record pressure. All pressure must be equal within 5 p.s.i. [0,4 kg/cm²] If clutch pressure varies in any one clutch more than 5 p.s.i. [0,4 kg/cm²], repair clutch.

If a flow meter is available install in line coming out of converter pump. See flow diagram for location of pressure on flow checks. Check pump volume at 2000 RPM and at low engine idle. Record readings. See pump volume specifications at 2000 RPM.

Install flow meter in the line coming from transmission to converter. Check oil volume at 2000 RPM and at low idle in the following speed selections. Record readings.

Forward — Low speed thru High

Reverse — Low speed

Subtract readings in each speed from pump volume reading to get transmission clutch leakage.

Example:	Pump Volume at idle	8 gal.	Pump volume	8 gal.
	Forward—Low speed thru High	6 gal.	Forward — Low speed	6 gal.
	Reverse—Low speed	6 gal.	Clutch leakage	2 gal.

If clutch leakage varies more than 1 gal. from one clutch to another, repair clutch.

LEAKAGE IN TRANSMISSION CLUTCHES

- Leakage in 3000 series must not exceed 4 gal. max.
- Leakage in 4000 series must not exceed 4 gal. max.
- Leakage in 5000 series must not exceed 4 gal. max.
- Leakage in 8000 series must not exceed 6 gal. max.
- Leakage in 16000 series must not exceed 7 gal. max.

CONVERTER LUBE FLOW

Disconnect CONVERTER DRAIN BACK line at transmission with engine running at 2000 RPM and measure oil into a gallon container. Measure oil leakage for 15 seconds and multiply the volume of oil by four to get gallons per minute leakage.

LEAKAGE IN CONVERTER

- Leakage in C270 series not to exceed 2 gal. max.
- Leakage in C5000 series not to exceed 3 gal. max.
- Leakage in C8000 series not to exceed 5 gal. max.
- Leakage in C16000 series not to exceed 5 gal. max.

LOW CLUTCH PRESSURE WITH NORMAL CLUTCH LEAKAGE

CAUSE

REMEDY

- | | |
|--------------------------------------------------------------------------------------------------------------------------------------------------------------------------------------------------------------------------------------------|-----------------------------------------------------------------------------------------------------------------------------------------------------------------------------------------------------|
| <ol style="list-style-type: none"> 1. Low Oil Level. 2. Broken spring in transmission regulator valve. 3. Clutch pressure regulator valve spool stuck in open position. 4. Faulty charging pump. | <ol style="list-style-type: none"> 1. Fill to proper level. 2. Replace spring. 3. Clean valve spool and sleeve. 4. See paragraph on charging pump output. |
|--------------------------------------------------------------------------------------------------------------------------------------------------------------------------------------------------------------------------------------------|-----------------------------------------------------------------------------------------------------------------------------------------------------------------------------------------------------|

LOW CLUTCH PRESSURE WITH EXCESSIVE CLUTCH LEAKAGE

- | | |
|-------------------------------------------------------------------------------------------------------------------------------------------------------------------------------------------------------------------------------------------------------------------------------|-------------------------------------------------------------------------------------------------------------------------------------------------------------------------------------------------------------|
| <ol style="list-style-type: none"> 1. Broken or worn clutch piston sealing rings. 2. Clutch drum bleed valve ball stuck in open position. 3. Broken or worn sealing rings on clutch support. 4. Low converter charging pump output. | <ol style="list-style-type: none"> 1. Replace sealing rings. 2. Clean bleed valve thoroughly. 3. Replace sealing rings. 4. See paragraph on charging pump output. |
|-------------------------------------------------------------------------------------------------------------------------------------------------------------------------------------------------------------------------------------------------------------------------------|-------------------------------------------------------------------------------------------------------------------------------------------------------------------------------------------------------------|

LOW CONVERTER CHARGING PUMP OUTPUT

CAUSE	REMEDY
1. Low oil level.	1. Fill to proper level.
2. Sump screen plugged.	2. Clean screen and sump.
3. Air leaks at pump intake hose and connections or collapsed hose.	3. Tighten all connections or replace hose if necessary.
4. Defective oil pump.	4. Replace pump.

LOW FLOW THROUGH COOLER WITH LOW CONVERTER IN PRESSURE

1. Defective safety by-pass valve spring.	1. Replace spring.
2. Converter by-pass valve partially open.	2. Check for worn by-pass ball seat.
3. Excessive converter internal leakage. (Check converter lube flow and drain.)	3. Remove, disassemble, and rebuild converter assembly, replacing all worn or damaged parts.
4. Broken or worn sealing rings in transmission clutches.	4. See paragraph on Clutch leakage.

LOW FLOW THROUGH COOLER WITH HIGH CONVERTER OUT PRESSURE

1. Plugged oil cooler. Indicated if transmission lube pressure is low.	1. Back flush and clean oil cooler.
2. Restricted cooler return line.	2. Clean out lines.
3. Lube oil ports in transmission plugged. Indicated if transmission lube pressure is high.	3. Check lube lines for restrictions.

OVERHEATING

1. Worn oil sealing rings. (Check converter lube flow and drain.)	1. Remove, disassemble, and rebuild converter assembly.
2. Worn oil pump.	2. Replace.
3. Low oil level.	3. Fill to proper level.
4. Pump suction line taking air.	4. Check oil line connections and tighten securely.

NOISY CONVERTER

1. Worn coupling gears.	1. Replace.
2. Worn oil pump.	2. Replace.
3. Worn or damaged bearings.	3. A complete disassembly will be necessary to determine what bearing is faulty.

LACK OF POWER

1. Low engine RPM at converter stall.	1. Tune engine check governor.
2. See "Over-heating" and make same checks.	2. Make corrections as explained in "Over-Heating."

