

9K324 STEERING CLUTCH GROUP

Serial No. 83J2177 to 83J3034 inclusive

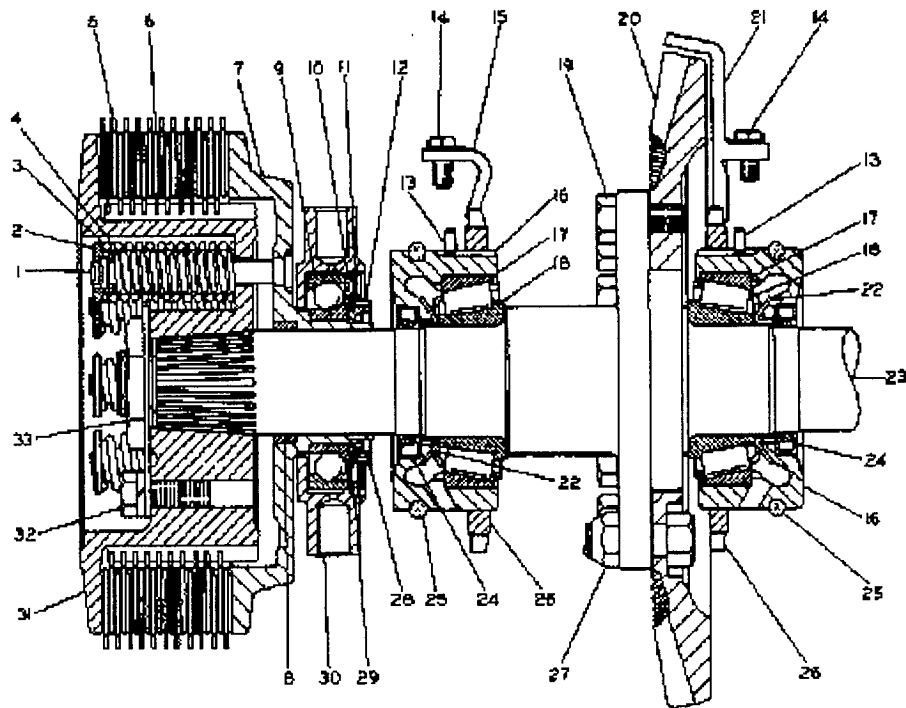

REF. NO.	PART NUMBER	DESCRIPTION	QTY
1	288759	STUD	16
2	289018	LOCK	32
2	289020	RETAINER	16
3	888807	SPRING (Outer)	16
4	898804	SPRING (Inner)	16
5	379904	DISC ASSEM. (19 Teeth)	22
6	286436	DISC	28
7	281086	PLATE ASSEM.	2
8	6H3569	BUSHING	2
9	184102	BEARING	1
10	9F3144	SEAL	2
11	3H7478	RING	2
12	6R9437	NUT	2
13	5130	PISTON	2
14	L1331	BOLT	2
14	L364	LOCK	2
15	4K4943	LOCK	1
16	4K4194	CAGE	2
17	6H3568	CUP	2
18	6H3568	CONE	2
19	51566	BOLT	11
20	9K322	BEAR	1
21	4K4877	DEFLECTOR	1
22	6H3581	THROWER	2
23	9K323	SHAFT	1
24	4K4304	SEAL	2
25	8F4469	SEAL	2
26	2B2728	NUT	2
27	8K5706	BOLT	1
27	2K557	LOCKNUT	1
28	4B9806	SCREW	4
29	LHT472	RING	2
30	6H7418	CAGE ASSEM.	2
30	2A3748	PLUG	2
31	6H374	DRUM	2
31	51624	BOLT	4
32	384510	LOCKWASHER	4
33	L2341	NUT	2
33	3B5528	LOCK	2

11349

Note	Ref	Number	Qty	Part Name
		9K-0324	1	STEERING CLUTCH GROUP
1		2B-8759	16	STUD
		2B-9018	32	LOCK
2		2B-9020	16	RETAINER
3		6B-8807	16	SPRING (Outer)
4		6B-8804	16	SPRING (Inner)
5		3F-5504	22	DISC ASSEM. (95 Teeth)
6		2H-6936	20	DISC
7		2M-1086	2	PLATE ASSEM.
8		6H-3569	1	BUSHING
9		1B-4102	2	BEARING
10		5F-3144	2	SEAL
11		1H-7478	2	RING
12		8K-9637	2	NUT
13		0S-0130	2	PIN
14		0L-1351	2	BOLT
		0L-0364	2	LOCK
15		4K-4943	1	LOCK
16		4K-4894	2	CAGE
17		6H-3568	2	CUP
18		6H-3566	2	CONE
19		0S-1566	11	BOLT
20		9K-0322	1	GEAR
21		4K-4877	1	DEFLECTOR
22		6H-3581	2	THROWER
23		9K-0323	1	SHAFT
24		4K-4390	2	SEAL

25	8F-4469	2	SEAL
26	2B-8778	2	NUT
27	9K-5706	1	BOLT
	2K-0337	1	LOCKNUT
28	4B-9806	4	SCREW
29	1H-7422	2	RING
30	9H-7418	2	CAGE ASSEM.
	2A-3746	2	PLUG
31	8H-1174	2	DRUM
32	0S-1624	4	BOLT
	3B-4510	4	LOCKWASHER
33	0L-2341	2	NUT
	3B-5524	2	LOCK

6K2380 BRAKE GROUP

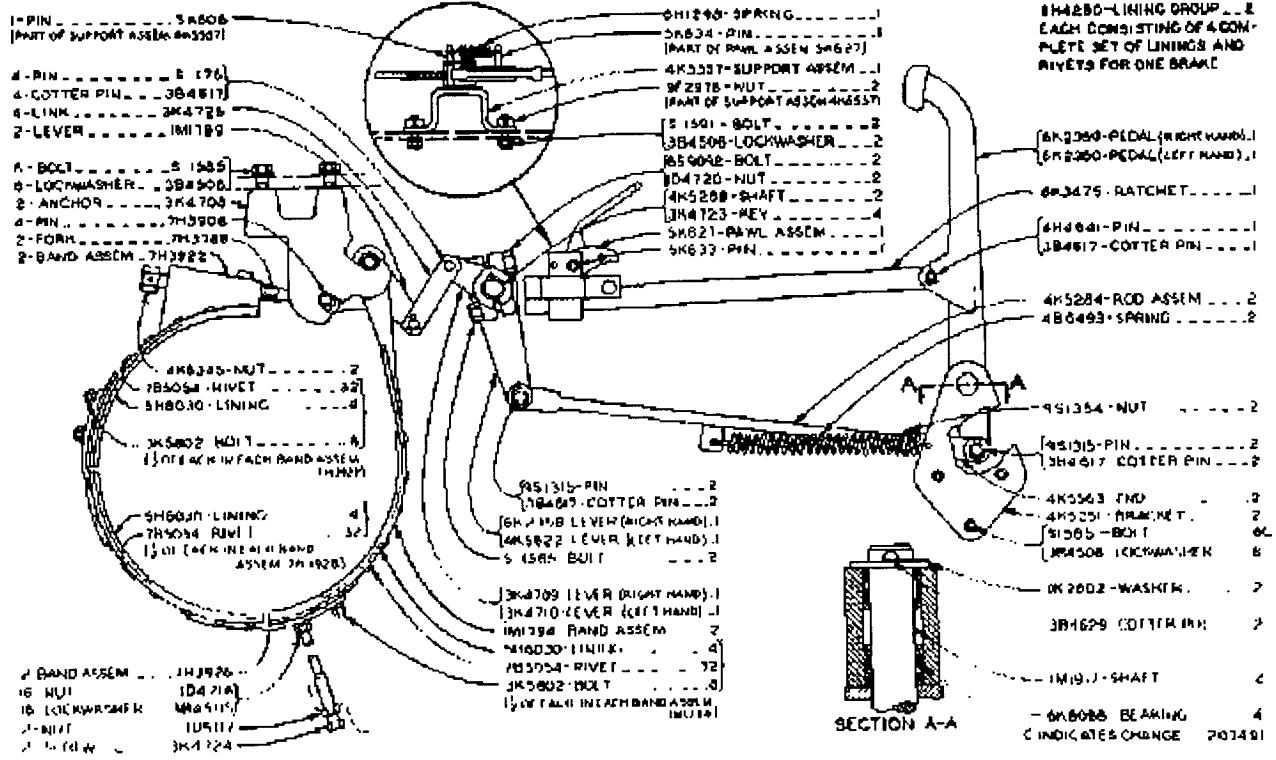

Note	Ref	Number	Qty	Part Name
		6K-2380	1	BRAKE GROUP
		5K-0606	1	PIN
				(PART OF SUPPORT ASSEM 4K5557)
		0S-0175	4	PIN
		3B-4617	4	COTTER PIN
		3K-4725	4	LINK
		1M-1789	2	LEVER
		0S-1585	8	BOLT
		3B-4508	8	LOCKWASHER
		3K-4708	2	ANCHOR
		7H-3908	4	PIN
		7H-3788	2	FORK
		7H-3922	2	BAND ASSEM
		4K-6345	2	NUT
		7B-5054	32	RIVET
		5H-6030	4	LINING
		3K-5802	8	BOLT
				(1/2 OF EACH IN EACH BAND ASSEM 7H3922)
		5H-6030	4	LINING
		7B-5054	32	RIVET
				(1/2 OF EACH IN EACH BAND ASSEM)
		7H-3926	2	BAND ASSEM
		1D-4716	16	NUT
		3B-4505	16	LOCKWASHER
		1D-5117	2	NUT
		3K-4724	2	SCREW
		6H-1298	1	SPRING

5K-0634 1 PIN

(PART OF PAWL ASSEM 5K627)

4K-5557 1 SUPPORT ASSEM

9F-2978 2 NUT

(PART OF SUPPORT ASSEM 4K5557)

0S-1591 2 BOLT

3B-4506 2 LOCKWASHER

8S-9092 2 BOLT

1D-4720 2 NUT

4K-5268 2 SHAFT

3K-4723 4 KEY

5K-0627 1 PAWL ASSEM.

5K-0633 1 PIN

9S-1315 2 PIN

3B-4617 2 COTTER PIN

6K-2358 1 LEVER (RIGHT HAND)

4K-5622 1 LEVER (LEFT HAND)

0S-1585 2 BOLT

3K-4709 1 LEVER (RIGHT HAND)

3K-4710 1 LEVER (LEFT HAND)

1M-1794 2 BAND ASSEM

5H-6030 4 LINING

7B-5054 32 RIVET

3K-5802 8 BOLT

(1/2 OF EACH IN EACH BAND ASSEM 1M1794)

9H-4280 2 LINING GROUP

EACH CONSISTING OF A COMPLETE SET OF LININGS AND RIVETS FOR ONE BRAKE

6K-2359 1 PEDAL (RIGHT HAND)

6K-2360 1 PEDAL (LEFT HAND)

	6K-3475	1	RATCHET
	4H-4641	1	PIN
	3B-4617	1	COTTER PIN
	4K-5284	2	ROD ASSEM
	4B-6493	2	SPRING
	9S-1354	2	NUT
	9S-1315	2	PIN
	3B-4617	2	COTTER PIN
	4K-5563	2	END
	4K-5251	2	BRACKET
C	0S-1585	6	BOLT
	3B-4508	6	LOCKWASHER
	1K-2602	2	WASHER
	3B-4629	2	COTTER PIN
	1M-1917	2	SHAFT
	6K-8088	4	BEARING

INDICATES CHANGE