

Steering Clutch

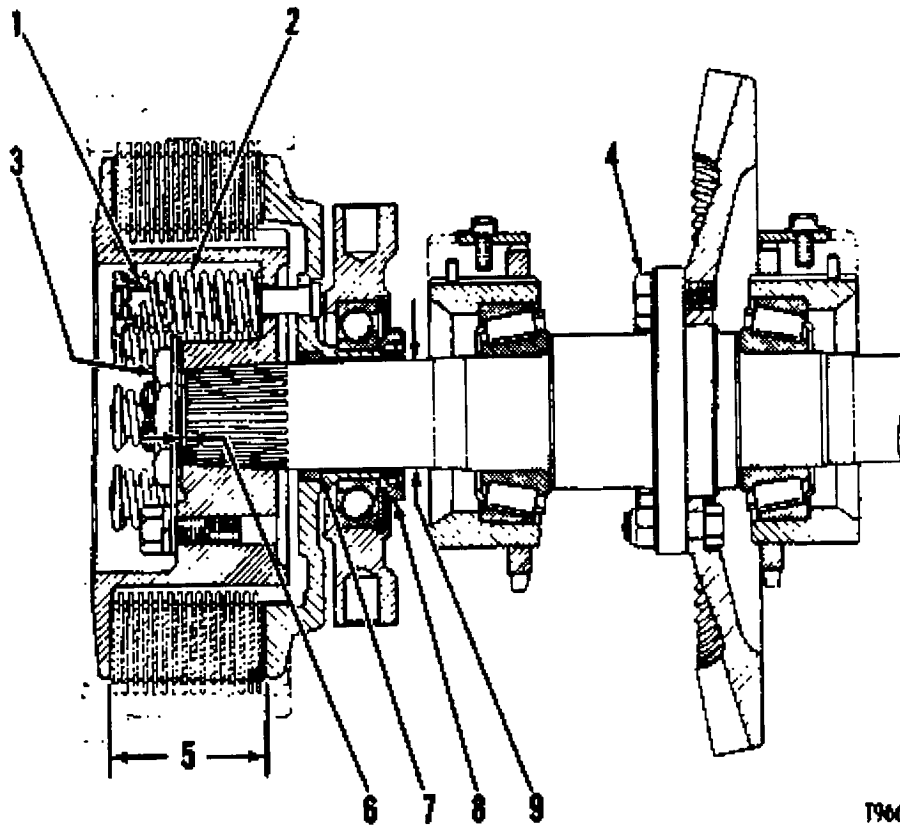

T96686-2x1

Amount of free movement (backlash) between the bevel gear and bevel pinion005 to .011 in. (0.13 to 0.28 mm)

(1) 6B8804 Spring (inner):

Length under test force . . . 2.812 in. (71.42 mm)

Test force . . . 123.5 to 136.5 lb. (550 to 608 N)

Free length after test . . . 3.266 in. (82.96 mm)

Outside diameter95 in. (24.13 mm)

(2) 4K1302 Spring (outer):

Color code . . . yellow stripe

Length under test force . . . 3.19 in. (81.03 mm)

Test force . . . 186.2 to 205.8 lb. (828 to 916 N)

Free length after test . . . 4.176 to 4.364 in. (106.07 to 110.85 mm)

Outside diameter . . . 1.438 in. (36.53 mm)

(3) Torque for nut . . . 200 to 300 lb. ft. (270 to 410 N m)

(4) Torque for 11 S1566 Bolts (5/8 in. diameter) . . . 200 to 240 lb. ft. (270 to 320 N m)

Torque for nuts (with eight bolts and 2K4821 Locknuts) . . . 175 to 195 lb. ft. (240 to 265 N m)

(5) Thickness of 16 new disc assemblies and 15 new discs . . . 3.218 to 3.442 in. (81.74 to 87.43 mm)

Minimum permissible thickness of 16 worn disc assemblies and 15 worn discs . . . 3.000 in. (76.20 mm)

Thickness of one new 5K8617 Disc Assembly131 to .141 in. (3.33 to 3.58 mm)

Thickness of one new 5K8616 Disc073 to .077 in. (1.85 to 1.96 mm)

Thickness of one new 4K1333 or 5V593 Disc Assembly158 to .172 in. (4.01 to 4.37 mm)

NOTE: The 4K1333 Disc Assembly must be installed next to the drum.

(6) Push drum onto shaft with a force of . . . 15 to 20 ton (135 to 180 kN)

Distance from shoulder of shaft to face of drum is expected (earlier machines)09 to .15 in. (2.3 to 3.8 mm)

Distance from shoulder of shaft to face of drum is expected (later machines)24 to .30 in. (6.1 to 7.6 mm)

(7) Clearance between bearing and shaft010 to .013 in. (0.25 to 0.33

mm)

Maximum clearance020 in. (0.51 mm)

**Minimum permissible bore of bearing after assembly into plate . . . 2.3675 in.
(60.134 mm)**

(8) Torque for nut . . . 200 to 300 lb. ft. (270 to 410 N m)

(9) Diameter of journal of shaft . . . 2.361 to 2.363 in. (59.97 to 60.02 mm)

**Copyright 1991, 2015 Caterpillar Inc.
All Rights Reserved.**