



**CATERPILLAR  
PARTS  
BOOK**

D3  
S400

**D3  
TRACTOR**

**SERIAL  
NUMBERS**

**79U1 TO 79U4708**

# QUICK REFERENCE CHARTS

USE THESE CHARTS TO RECORD FREQUENTLY USED MAINTENANCE INFORMATION

MACHINE SERIAL NO.	
EQUIPMENT NO.	

## FREQUENTLY REPLACED ITEMS

PART NO.	PART NAME

## FLUIDS & LUBRICANTS

WHERE USED	TYPE	AMOUNT

## OTHER MAINTENANCE ITEMS

# CONTENTS

ALPHABETICAL INDEX OF GROUPS... 3  
 CONVERSION EQUIVALENT  
 TABLES           INSIDE BACK COVER  
 ORDERING PARTS..... 2  
 QUICK REFERENCE  
 CHART            INSIDE FRONT COVER  
 USING THE PARTS BOOK..... 2

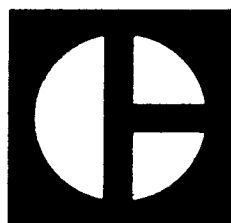

## PARTS BOOK

# D3 TRACTOR

SERIAL NUMBER  
**79U1 TO 79U4708**

REVISION PUBLISHED DECEMBER 1979  
 CATERPILLAR TRACTOR CO.  
 PUBLICATIONS DIV.—SERVICE G.O.  
 PEORIA, ILL. U.S.A.

# QUICK REFERENCE GUIDE TO MAJOR SECTIONS

- ENGINE RELATED PARTS
- STARTING & ELECTRICAL SYSTEM
- POWER TRAIN—  
POWER TRANSMISSION UNIT
- STEERING CLUTCHES & BRAKES
- CHASSIS & UNDERCARRIAGE
- HYDRAULIC SYSTEM
- CAB, GAUGES & ACCESSORIES
- SERVICE EQUIPMENT & SUPPLIES
- 
- 
- 
- 
-

**ORDERING PARTS** Quality Caterpillar Replacement parts are available from Caterpillar dealers throughout the world. Their parts stocks are up to date and include all parts normally required to protect your investment in Caterpillar machines. When ordering parts, always use the Parts Book covering the serial number of your machine. Your order should specify the quantity, part number, part name and show the machine serial number for which the parts are needed. If in doubt about the part number, please provide your dealer with a complete description of the needed item.

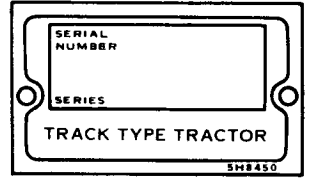

Serial Number Plate is located on Right Rear side of steering Clutch Case.

**HOW TO USE THE PARTS BOOK** Caterpillar Parts Books include illustrations of the groups or assemblies which make up the machine. These illustrations show the standard components of the machine plus many of the attachments available for the machine.

The alphabetical index located in the front part of the book should be used to determine the page number on which specific illustrations are shown. Reference to those pages will identify each of the individual serviceable parts.

#### Captions

The caption under each illustration identifies the part number and name of the group or assembly shown. If more than one illustration is included for any group, the caption identifies the specific machine serial numbers to which each illustration applies. In some cases it is not possible to determine the specific machine serial numbers to which different illustrations are applicable. In those cases the caption identifies the illustration as "First Type", "Second Type", etc. Reference to the actual group or assembly is necessary in those cases to determine which illustration should be used.

Captions provide additional information such as page numbers where illustrations of sub assemblies are shown, information regarding quantities used and other information intended to assist the user in determining parts needs.

#### Indented Part Names

Within each illustration is a parts list identifying each serviceable part in the illustration. When a part name is indented in this list, it means that serviceable item is a part of the serviceable item under which it is indented.

#### Abbreviations and Symbols

- ▲ Used to call attention to additional information shown elsewhere within the illustration.
- 
- R.H. Right Hand Refers to the side of the machine as viewed from the operator's compartment.
- L.H. Left Hand
- C Indicates changes from the previous illustration of the same group or assembly.
- O.D. Outside Diameter
- I.D. Inside Diameter
- N/S Not Serviced
- Assem. Assembly
- in. Inch
- ft Foot
- cm Centimeter
- dm Decimeter

#### Note:

Continuing improvement and advancement of product design may cause changes to your machine which may not be included in this publication. Each publication is reviewed and revised, as required, to update and include these changes in later editions.

Whenever a question arises regarding your Caterpillar product, or this publication, please consult your Caterpillar dealer for the latest available information.

# INDEX

THIS TRACTOR IS EQUIPPED WITH A 3204 ENGINE

FOR ENGINE PARTS INFORMATION USE THE PARTS BOOK FOR  
3204 ENGINE, SERIAL NO. 45VI — UP

THE SERIAL NUMBER PLATE ON THE ENGINE BLOCK PROVIDES  
SPECIFIC ENGINE IDENTITY

## Engine Related Items

(Page 10)

Name	Page
Air Cleaner	14
Blower Fan and Guard	13
Brush Guard	11B & 12A
Engine & Transmission Support	19
Exhaust Extension	15
Fuel Lines	20
Fuel Tank	21
Fuel Tank Cap	20
Governor and Transmission Control	18
Governor Control	17
Hour Meter	19
Muffler	16
Oil Filler Extension	22
Prescreener	15
Radiator	10
Radiator Guard	11
Spark Arrestor	16-2
Suction Fan	13
Sweep	16C
Torque Converter Cooler Lines	12

## Starting and Electrical System

(Page 22)

Backup Warning	27A
Battery	22
Battery and Wiring	24
Lighting	26

## Power Train - Power Transmission Unit

(Page 28)

Final Drive	40
Power Take-Off Drive	39
Power Train	28
Torque Converter	30

Name

Page

Transfer Gears	34
Transmission	29
Transmission Control	31
Transmission Lubrication System Control	36
Transmission Oil Filler	29
Transmission—Planetary	32
Winch Drive	39A

## Steering Clutches and Brakes

(Page 42)

Bevel Gear	42
Steering Brake	46
Steering Clutch	45
Steering Clutch Case	44
Steering Clutch Control	50

## Chassis and Undercarriage

(Page 52)

Counterweight—Front	60A
Crankcase Guard	61
Drawbar	53
Engine Enclosure	54
Firewall	56
Frame	52
Front Idler	58
Front Pull Hook	54
Hood and Guard	55
Recoil Mechanism Guard	60
Track	66
Track Carrier Roller	64
Track Guiding Guard	63
Track Roller	65
Track Roller Frame	62
Track Roller Guard	63
Undercarriage Support	57

## Hydraulic System

(Page 68)

Name	Page
Gear Pump	79
Hydraulic Arrangement	71
Hydraulic Tank and Valve	68
Hydraulic Tank Cap	70
Lines and Pump	80D
Piston Pump	80F

## Cab, Gauges and Accessories

(Page 84)

Cab Heater	98
Defrosting Fan	99
Dash	88
Electric Horn	86B
Gauges	87
Mounting—ROPS	97
Operator Protective Cab	89

Name

Page

Operator Protective Cab Conversion	90
Rollover Protective Structure	97
Sound Suppression	88A
Support and Seat	84
Suspension Seat	86
Vandalism Protection	89
Windshield Washer and Wiper	100

## Service Equipment and Supplies

(Page 102)

Films	104
Hand Tool	102
Specifications	106

# INDEX ALPHABÉTIQUE

CE TRACTEUR EST MUNI D'UN MOTEUR 3204.

POUR LES PIÈCES DE RECHANGE DU MOTEUR, VOIR LE CATALOGUE DE PIÈCES DES MOTEURS 3204 À PARTIR DU NUMÉRO DE SÉRIE 45VI.

LA PLAQUE FIXÉE AU BLOC-MOTEUR DONNE LE NUMÉRO DE SÉRIE ET AUTRES RÉFÉRENCES DU CATALOGUE.

## Pièces de complément du moteur

(Page 10)

Désignation	Page
Bouchon du réservoir de carburant	20
Canalisations de carburant	20
Commandes de régulateur et de vitesses	18
Convertisseur (tuyauterie du réfrigérant)	12
Filtre à air	14
Horomètre	19
Préfiltre à air	15
Protège-radiateur	11
Radiateur	10
Régulateur (timonerie extérieure)	17
Réservoir de carburant	21

Désignation

Page

Silencieux d'échappement	16
Support du moteur et de la boîte de vitesses	19
Tubulure de remplissage d'huile (rallonge)	22
Tuyau d'échappement (rallonge)	15
Ventilateur aspirant	13
Ventilateur soufflant et protège-ventilateur	13

## Démarrage et installation électrique

(Page 22)

Batterie	22
Batterie et câblage	24
Éclairage	26

## Train de transmission (Page 28)

Désignation	Page
Circuit de graissage de la transmission (commande) . . . . .	36
Commande hydraulique de vitesses . . . . .	31
Convertisseur de couple . . . . .	30
Engrenages de transfert . . . . .	34
Mécanisme de transmission . . . . .	28
Réducteur latéral . . . . .	40
Transmission . . . . .	29
Transmission à trains planétaires . . . . .	32
Treuil (entraînement) . . . . .	39
Tubulure de remplissage d'huile de la boîte de vitesses . . . . .	29

## Embrayages de direction et freins (Page 42)

Cartier d'embrayage de direction . . . . .	44
Commandes d'embrayage de direction . . . . .	50
Couple conique . . . . .	42
Embrayages de direction . . . . .	45
Freins de direction . . . . .	46

## Bâti et train de roulement (Page 52)

Barre d'attelage . . . . .	53
Capot et protège-radiateur . . . . .	55
Chaînes de roulement . . . . .	66
Châssis . . . . .	52
Châssis porteurs . . . . .	62
Cloison pare-feu . . . . .	56
Crochet d'attelage avant . . . . .	54
Galets inférieurs . . . . .	65
Galets supérieurs . . . . .	64
Guide-protecteur de chaîne . . . . .	63

Désignation	Page
Panneaux latéraux de capot . . . . .	54
Protections du tendeur de chaîne . . . . .	60
Protège-carter moteur . . . . .	61
Protège-galets . . . . .	63
Roue AV . . . . .	58
Support de train de roulement . . . . .	57

## Commande hydraulique (Page 68)

Bouchon du réservoir hydraulique . . . . .	70
Commande hydraulique . . . . .	71
Réservoir hydraulique et distributeur . . . . .	68

## Cabine, instruments de contrôle et accessoires (Page 84)

Bâti de sécurité . . . . .	97
Cabine de sécurité . . . . .	89
Essuie-glace et lave-glace . . . . .	100
Dégivreur . . . . .	99
Groupe de montage de cabine de protection . . . . .	90
Instruments . . . . .	87
Protections contre le vandalisme . . . . .	89
Siège et support de siège . . . . .	84
Siège suspendu . . . . .	86
Supports de fixation pour bâti de sécurité . . . . .	97
Tableau de bord . . . . .	88

## Divers (Page 102)

Caractéristiques . . . . .	107
Décalcomanies . . . . .	104
Outils à main . . . . .	102

# INDICE

ESTE TRACTOR TIENE UN MOTOR 3204.

LA INFORMACION ACERCA DE LAS PARTES DEL MOTOR SE ENCUENTRA EN EL CATALOGO DE REPUESTOS PARA LOS MOTORES 3204, CON NO. DE SERIE 45VI y SIGUIENTES.

LA PLACA CON EL NO. DE SERIE EN EL BLOQUE DEL MOTOR PROVEE LA IDENTIFICACION ESPECIFICA DEL MOTOR.

## Partes Relacionadas con el Motor (Página 10)

Nombre	Página
Antefiltro especial	15
Control del regulador	17
Control del regulador y transmisión	18
Extensión del tubo de llenado del aceite	22
Filtro de aire	14
Medidor de servicio	19
Protección del radiador	11
Radiador	10
Silenciador	16
Soporte del motor y de la transmisión	19
Tanque del combustible	21
Tapa del tanque de combustible	20
Tuberías del combustible	20
Tuberías del enfriador del convertidor de par	12
Tubo de escape	15
Ventilador de succión	13
Ventilador insuflador y protección	13

## Sistema Eléctrico y de Arranque (Página 22)

Batería	22
Batería y alambrado	24
Luces	26

## Tren de Potencia — Transmisión de Fuerza (Página 28)

Control del sistema de lubricación de la transmisión	36
Control hidráulico de la transmisión	31
Convertidor de par	30
Engranajes de transferencia	34
Mando del huinche	39
Mandos finales	40
Transmisión	29
Transmisión planetaria	32
Tren de potencia	28

Nombre	Página
Tubo de llenado del aceite de la transmisión	29

## Embragues de Dirección y Frenos (Página 42)

Compartimiento de embragues de dirección	44
Control de embragues de dirección	50
Corona	42
Embrague de dirección	45
Freno de la dirección	46

## Tren de Rodaje y Chasis (Página 52)

Barra de tiro	53
Bastidor	52
Bastidor de los rodillos	62
Capota y protección	55
Carril	66
Cubierta del motor	54
Gancho delantero	54
Plancha de separación del motor	56
Protección de los rodillos	63
Protección de resorte tensor	60
Protección del cárter	61
Protección guía del carril	63
Rodillos inferiores	65
Rodillos superiores	64
Rueda guía	58
Soporte del tren de rodaje	57

## Sistema Hidráulico (Página 68)

Conjunto hidráulico	71
Tanque hidráulico y válvula	68
Tapa del tanque hidráulico	70

## Cabina, Instrumentos y Accesorios (Página 84)

Asiento y soporte	84
Cabina protectora	89



Nombre	Página
Conversión para cabina protectora .....	90
Estructura protectora contra vuelcos .....	97
Instrumentos .....	87
Limpiador y lavador del parabrisas .....	100
Montaje para estructura protectora contra vuelcos .....	97

Nombre	Página
Protección contra vandalismo ..	89
Suspensión del asiento .....	86
Tablero .....	88
Ventilador descongelador .....	99

### **Materiales Diversos** (Página 102)

Calcomanías .....	104
Especificaciones .....	108
Herramientas de mano .....	102

# ÍNDICE

O MOTOR DESTA MÁQUINA É O MODELO 3204.

PARA INFORMAÇÕES SOBRE PEÇAS DO MOTOR VEJA O CATÁLOGO DE PEÇAS DOS MOTORES 3204 COM NÚMERO DE SÉRIE A PARTIR DE 45VI.

A PLACA DO NÚMERO DE SÉRIE NO BLOCO DO MOTOR O IDENTIFICA ESPECIFICAMENTE.

## **Partes da máquina relativas ao motor**

(Página 10)

Designação	Página
Bocal de enchimento de óleo ...	22
Controle de aceleração .....	17
Controle de aceleração e marchas	18
Extensão do tubo de descarga ..	15
Marcador de horas de serviço ..	19
Moldura do radiador .....	11
Purificador de ar .....	14
Radiador .....	10
Silenciador .....	16
Suportes do motor e caixa de mudanças .....	19
Tampa do tanque de combustível	20
Tanque de combustível .....	21
Tubos injetores .....	20
Tubulações do arrefecedor de óleo do conversor .....	12
Ventilador soprador e protetor ..	13
Ventilador succionador .....	13

## **Sistema elétrico e de partida**

(Página 22)

Designação	Página
Bateria .....	22
Bateria e instalação elétrica .....	24
Sistema de iluminação .....	26

## **Sistema de transmissão**

(Página 28)

Bocal de enchimento de óleo ...	29
Caixa de mudanças .....	29
Comando do guincho .....	39
Comando final .....	40
Controle hidráulico das marchas ..	31
Conversor de torque .....	30
Engrenagens da caixa de mudanças .....	32
Engrenagens de transferência ...	34
Sistema de transmissão .....	28
Sistema de lubrificação da caixa de mudanças .....	36

## **Direção e freios** (Página 42)

Designação	Página
Caixa da coroa .....	42
Caixa das embreagens de direção	44
Controle das embreagens de direção .....	50
Embreagem de direção .....	45
Freio da embreagem de direção .	46

## **Chassi e material rodante** (Página 52)

Armação dos roletes de esteira .	62
Barra de tração .....	53
Capô e tampas laterais .....	54
Chassi .....	52
Esteira .....	66
Gancho dianteiro .....	54
Painel traseiro do motor .....	56
Protetor do cárter .....	55 e 61
Protetor dos roletes de esteira ..	63
Protetor e guia das esteiras .....	63
Roda-guia .....	58
Rolete inferior .....	65
Rolete superior .....	64
Suporte nas armações dos roletes	57
Tampa da mola tensora .....	60

## **Sistema hidráulico** (Página 68)

Designação	Página
Arranjo hidráulico .....	71
Reservatório hidráulico e válvula .	68
Tampa do reservatório hidráulico	70

## **Cabine, indicadores e acessórios** (Página 84)

Assento com suspensão .....	86
Cabine de segurança .....	89
Conversão para cabine de segurança .....	90
Degelador do pára-brisa .....	99
Estrutura contra capotagem ....	97
Indicadores .....	87
Limpador e lavador do pára-brisa	100
Montagem da estrutura contra capotagem .....	97
Painel de instrumentos .....	88
Suporte e assento .....	84
Tampas com cadeado .....	89

## **Diversos** (Página 102)

Decalcomanias .....	104
Especificações .....	109
Ferramentas manuais .....	102

# **INHALTSVERZEICHNIS**

DIESE MASCHINE IST MIT EINEM MOTOR 3204 BESTÜCKT.

ERSATZTEILE FÜR DIESEN MOTOR SIND IM ERSATZTEILBUCH FÜR MOTOREN 3204 AB SERIENNUMMER 45VI AUFGEFÜHRT.

DAS SERIENNUMMERNESCHILD AM MOTORBLOCK DIENT ZUR GENAUEN TYPENBESTIMMUNG.

## **Motorzubehör** (Seite 10)

Bezeichnung	Seite
Auspuffrohrverlängerung .....	15
Drucklüfter und Verkleidung .....	13
Füllstützenverlängerung .....	22

Bezeichnung	Seite
Kraftstoffleitungen .....	20
Kraftstofftank .....	21
Kühlernetz .....	10
Kühlerschutz .....	11
Luftreiniger .....	14
Motor- und Getriebeaufhängung	19

Bezeichnung	Seite
Regler und Schaltgestänge	18
Reglersteuerung	17
Sauglüfter	13
Schalldämpfer	16
Tankkappe	20
Vorabscheider	15
Wandlerkühlleitungen	12
Wartungsmesser	19

### **Anlasser und elektr. Anlage (Seite 22)**

Batterie	22
Batterie und Verdrahtung	24
Beleuchtungsanlage	26

### **Kraftübertragung — Getriebe (Seite 28)**

Drehmomentwandler	30
Getriebe	29
Getriebefüllstutzen	29
Getriebehydraulik	31
Getriebschmiersystem	36
Kraftübertragung	28
Planetengetriebe	32
Seilwindenantrieb	39
Seitenantrieb	40
Vorgelege	34

### **Lenkkupplung und Bremsen (Seite 42)**

Lenkbremse	46
Lenkkupplung	45
Lenkkupplungsgehäuse	44
Lenkkupplungsgestänge	50
Tellerrad	42

### **Fahr- und Laufwerk (Seite 52)**

Feuerschutzwand	56
Frontzughaken	54
Hauptrahmen	52

Bezeichnung	Seite
Kettenführungsplatten	63
Kettenspannerverkleidung	60
Laufkette	66
Laufrollen	65
Laufrollenschutz	63
Laufwerksauflager	57
Laufwerksrahmen	62
Leitrad	58
Motorhaube und Verkleidung	55
Motorverkleidung	54
Panzerwanne	61
Stützrolle	64
Zughaken	53

### **Hydraulikanlage (Seite 68)**

Hydraulikanordnungen	71
Hydrauliktank und Ventil	68
Hydrauliktankkappe	70

### **Fahrerhaus, Armaturen und Zubehör (Seite 84)**

Armaturenbrett	88
Anzeigen	87
Entfrostergebläse	99
Fahrerhaus	89
Fahrerhaus-Umbaugruppe	90
Fahrersitz und Unterbau	84
Fahrersitzfederung	86
Scheibenwischer und -waschanlage	100
Schutzabdecke	89
Überroll-Schutzdach	97
Überroll-Schutzdachstreben	97

### **Wartungsgerät und Zubehör (Seite 102)**

Abziehbilder	104
Handwerkzeuge	102
Technische Daten	110

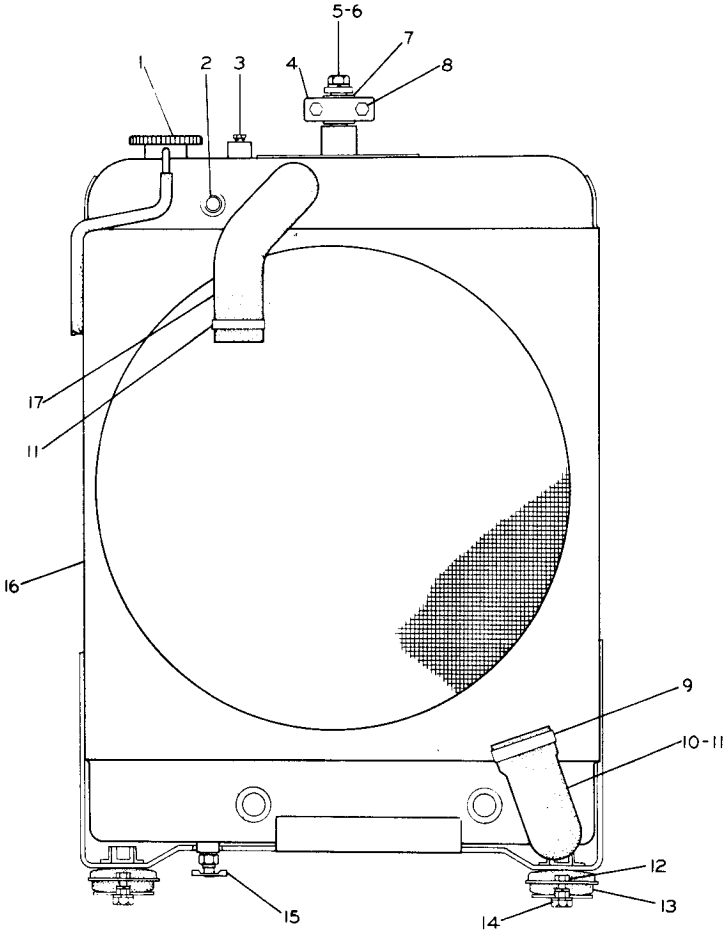

REF. NO.	PART NUMBER	DESCRIPTION	QTY
C 1	321464	CAP ASSEM. -----	1
2	8M4438	SEAL -----	1
3	4N499	BULB -----	1
4	5M6214	PLUG -----	1
5	1M6298	CLAMP -----	2
6	1A5822	BOLT -----	1
7	1F7960	WASHER -----	1
8	3B4508	LOCKWASHER -----	3
9	3H8726	BLOCK -----	1
	S1619	BOLT -----	2
	1D4717	NUT -----	2
	3B4506	LOCKWASHER -----	3
	4B4278	WASHER -----	2
C 9	5P598	CLAMP -----	1
C 10	4N2226	HOSE ----- (Outlet) -----	1
11	5P597	CLAMP -----	3
12	2B2695	BOLT -----	4
	1D4716	NUT -----	4
	3B4504	LOCKWASHER -----	4
13	8S9378	MOUNT -----	2
14	1A1460	BOLT -----	2
	1B4287	WASHER -----	2
15	1P7297	VALVE -----	1
16	4N2225	RADIATOR ASSEM. -----	1
17	4N325	HOSE ----- (Inlet) -----	1

C INDICATES CHANGE

152600

4N311 RADIATOR GROUP

Serial No. 79U1 to 673, 682, 685, 694, 719, 735 to 742, 744 and 79U1971 inclusive

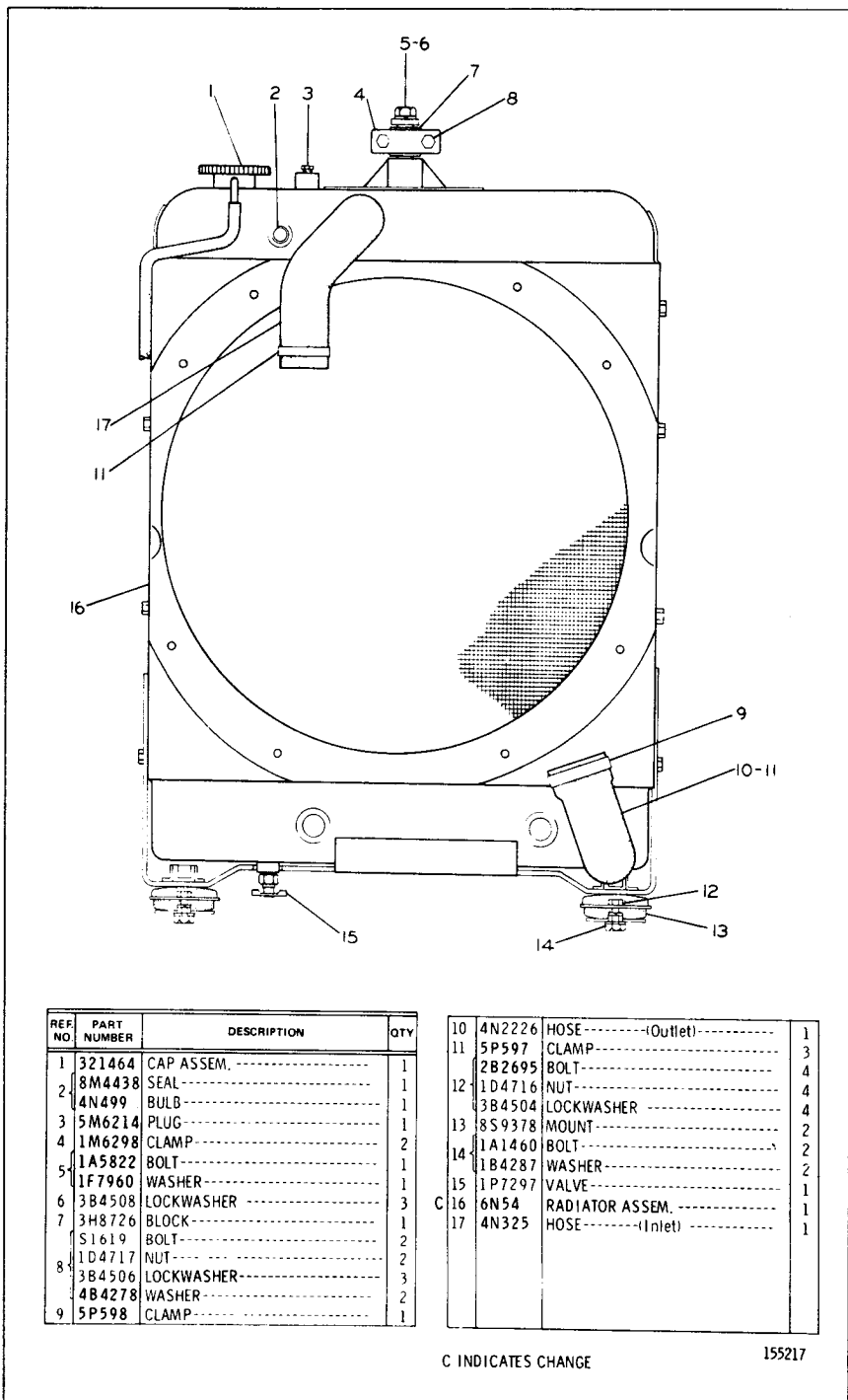

REF. NO.	PART NUMBER	DESCRIPTION	QTY
1	321464	CAP ASSEM. ....	1
2	8M4438	SEAL .....	1
	4N499	BULB .....	1
3	5M6214	PLUG .....	1
4	1M6298	CLAMP .....	2
5	1A5822	BOLT .....	1
	1F7960	WASHER .....	1
6	3B4508	LOCKWASHER .....	3
7	3H8726	BLOCK .....	1
8	S1619	BOLT .....	2
	1D4717	NUT .....	2
8	3B4506	LOCKWASHER .....	3
	4B4278	WASHER .....	2
9	5P598	CLAMP .....	1

10	4N2226	HOSE----- (Outlet) .....	1
11	5P597	CLAMP .....	3
	2B2695	BOLT .....	4
12	1D4716	NUT .....	4
	3B4504	LOCKWASHER .....	4
13	8S9378	MOUNT .....	2
14	1A1460	BOLT .....	2
	1B4287	WASHER .....	2
15	1P7297	VALVE .....	1
C 16	6N54	RADIATOR ASSEM. ....	1
17	4N325	HOSE----- (Inlet) .....	1

C INDICATES CHANGE

155217

4N311 RADIATOR GROUP  
 Serial No. 79U674 to 681, 683, 684, 686 to 693, 695 to 718, 720 to 734, 743, 745 to 1970 and 79U1972—Up

## CATERPILLAR D3 TRACTOR

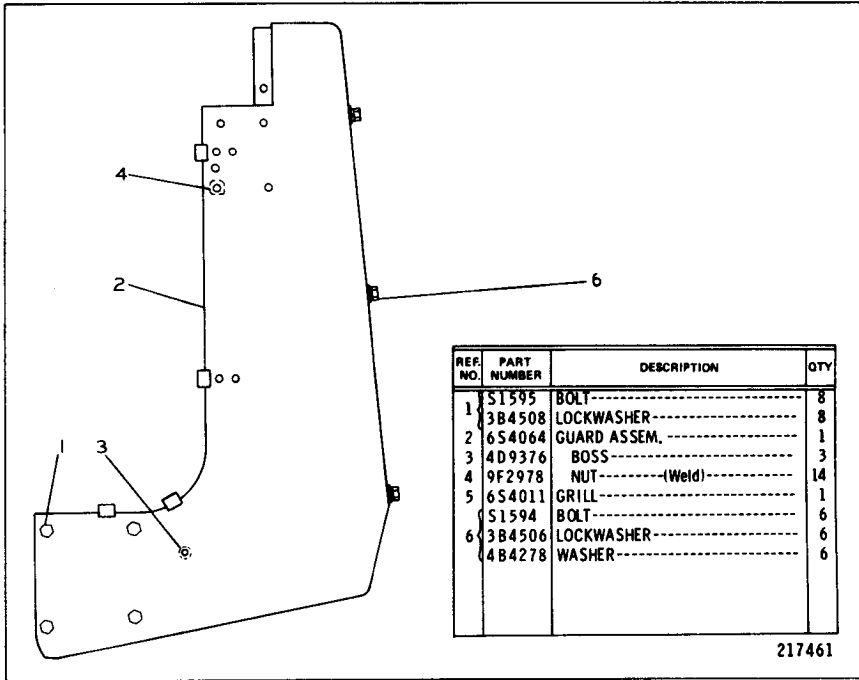

6S3512 RADIATOR GUARD GROUP  
Serial No. 79U1 to 79U4505 inclusive

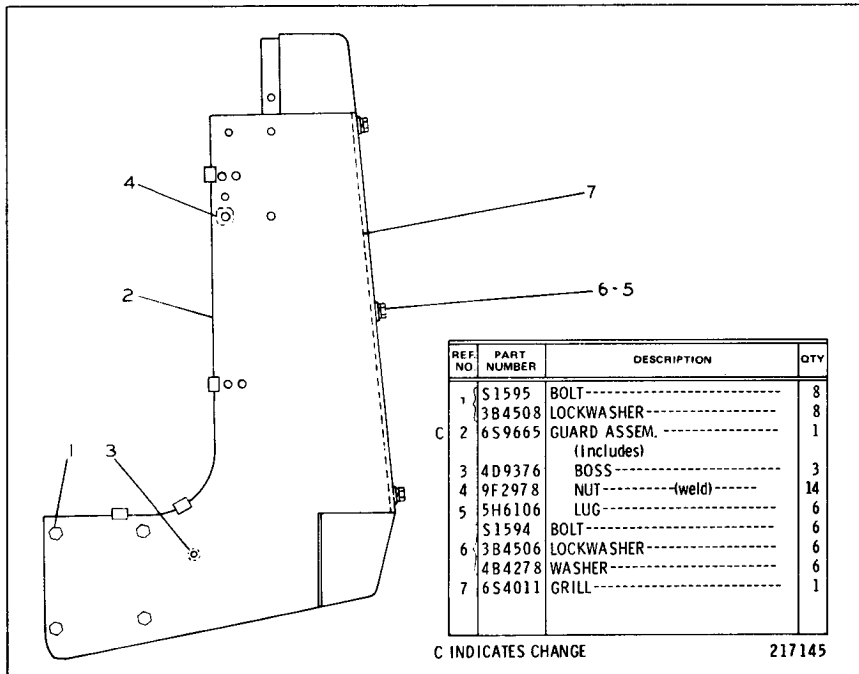

6S3512 RADIATOR GUARD GROUP  
Serial No. 79U4506—Up

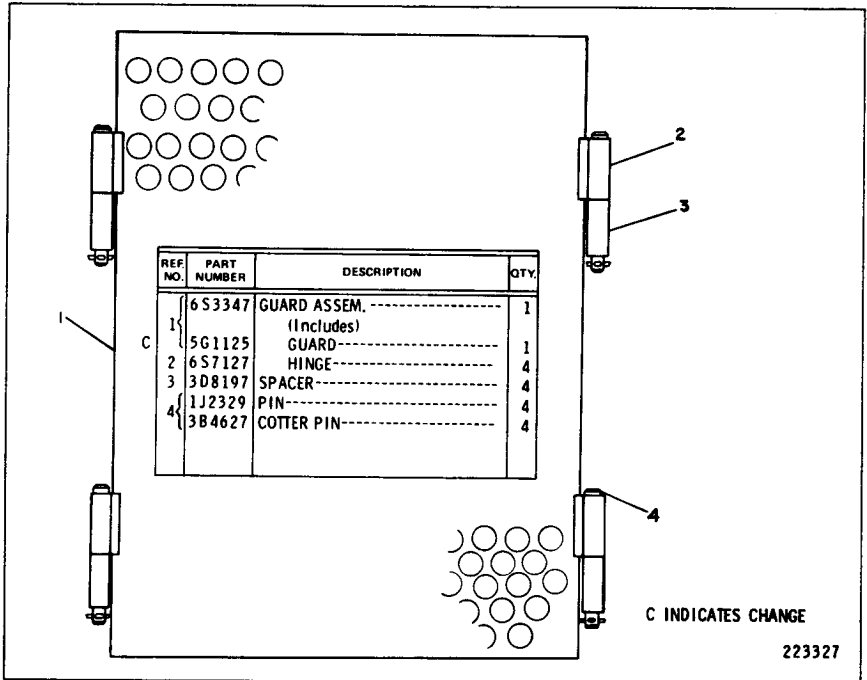

6S6166 RADIATOR GUARD GROUP—Hinged AN ATTACHMENT

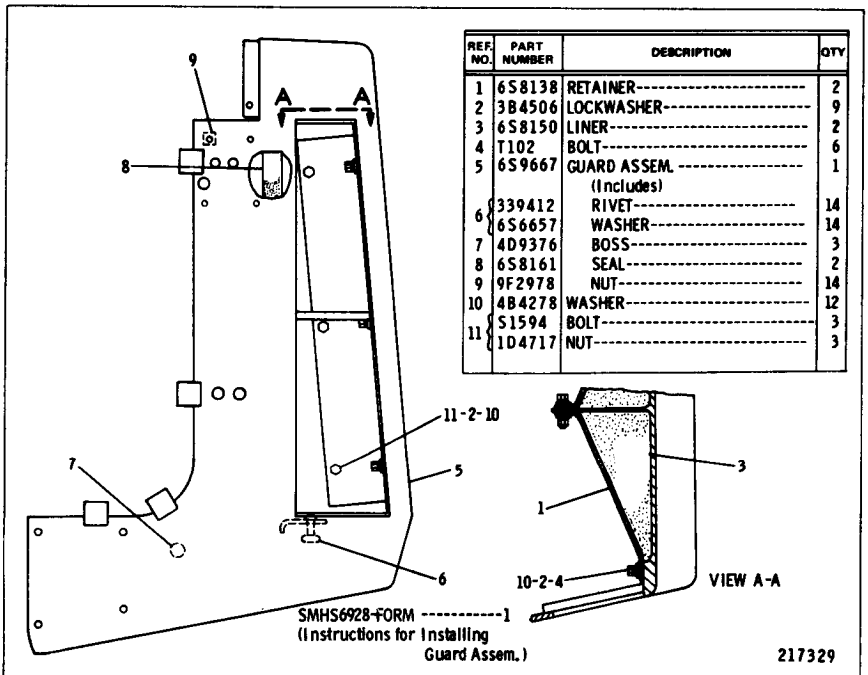

6S9697 RADIATOR GUARD GROUP  
Part of 6S8500 Sound Suppression Arrangement listed on Page 88A  
AN ATTACHMENT

CATERPILLAR D3 TRACTOR

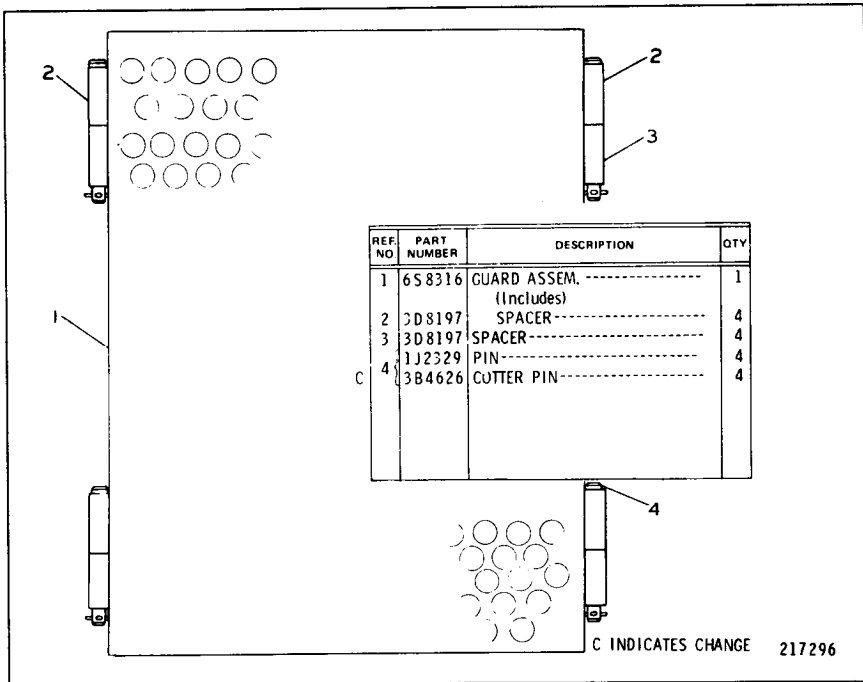

6S8323 RADIATOR GUARD GROUP—Hinged—Heavy Duty  
FOR USE IN LOGGING OR OTHER SEVERE APPLICATIONS  
AN ATTACHMENT

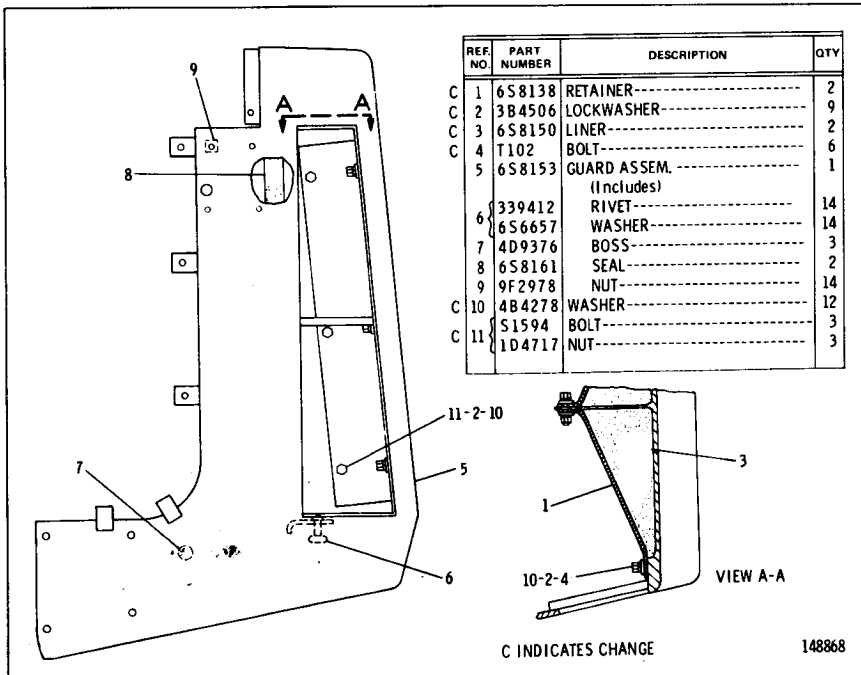

6S8174 RADIATOR GUARD GROUP—Replaced by 6S9697 shown on Page 11  
Part of 6S8500 Sound Suppression Arrangement listed on Page 88A



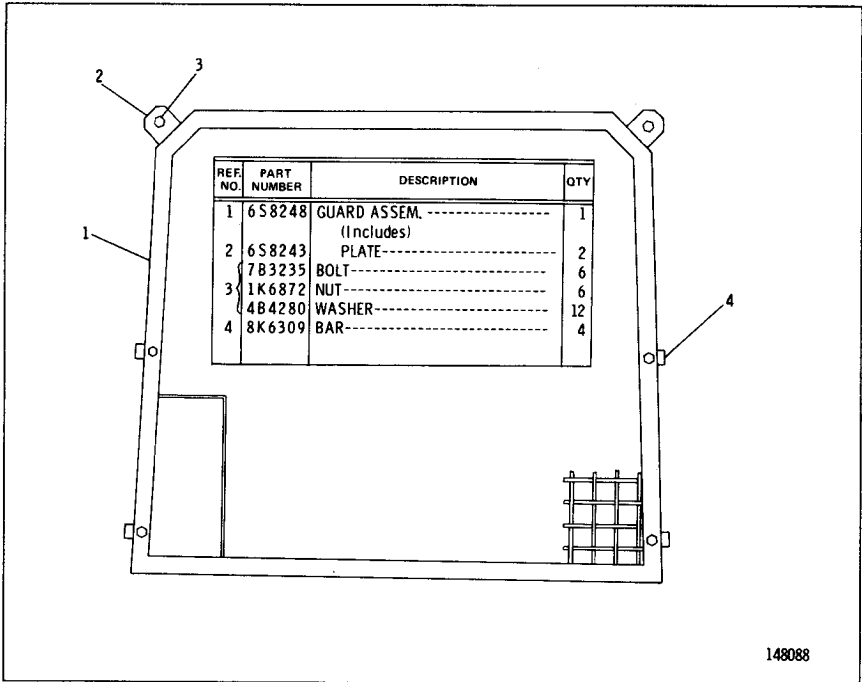

148088

6S8271 BRUSH GUARD GROUP—Type 1  
AN ATTACHMENT

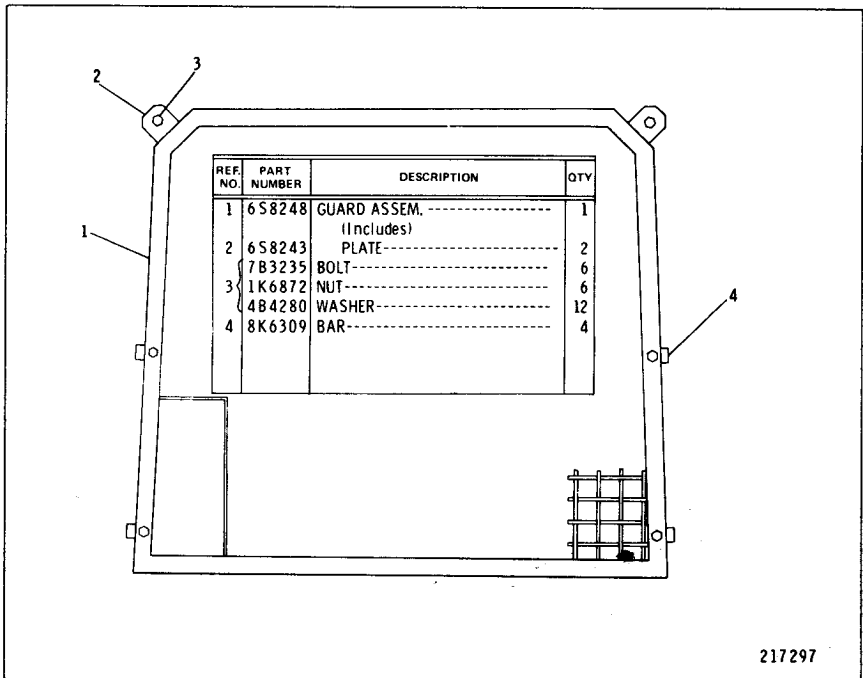

217297

6S8271 BRUSH GUARD GROUP—Type 2  
AN ATTACHMENT



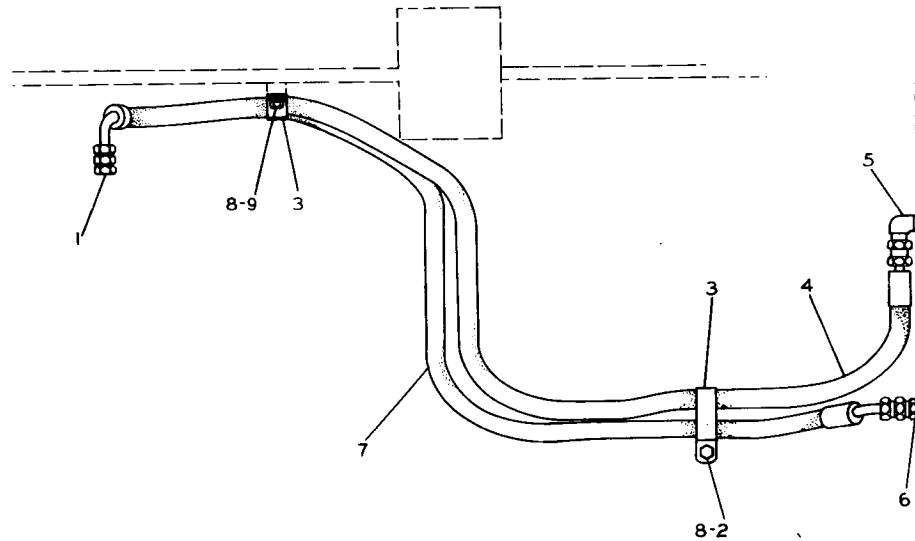

REF. NO.	PART NUMBER	DESCRIPTION	QTY
1	308196	CONNECTOR-----	2
2	2M9780	SEAL-----	2
3	S509	BOLT-----	1
4	7L7304	CLIP-----	2
4	6S7092	HOSE ASSEM. 1.684 m(66.30 in.)	1
5	16301	ELBOW-----	1
6	4S6678	CONNECTOR-----	1
7	6S7093	HOSE ASSEM. --1.49 m(58.66 in.)	1
8	3B4506	LOCKWASHER-----	2
9	L1351	BOLT-----	1
	4B4278	WASHER-----	1

C INDICATES CHANGE

217436

6S3534 TORQUE CONVERTER COOLER LINES GROUP

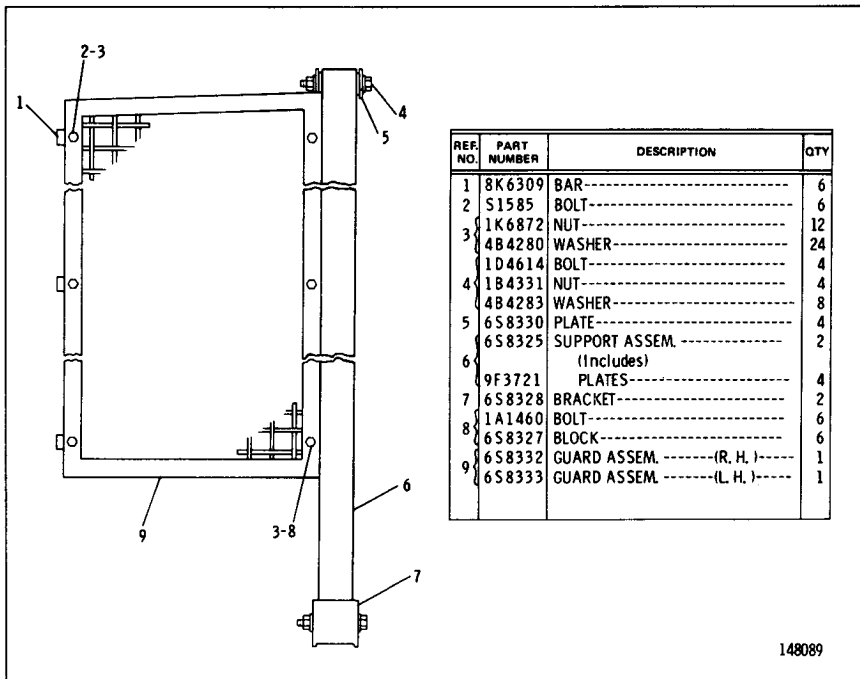

6S8348 BRUSH GUARD GROUP—Side  
FOR USE WITH ROLL-OVER PROTECTIVE STRUCTURE  
AN ATTACHMENT

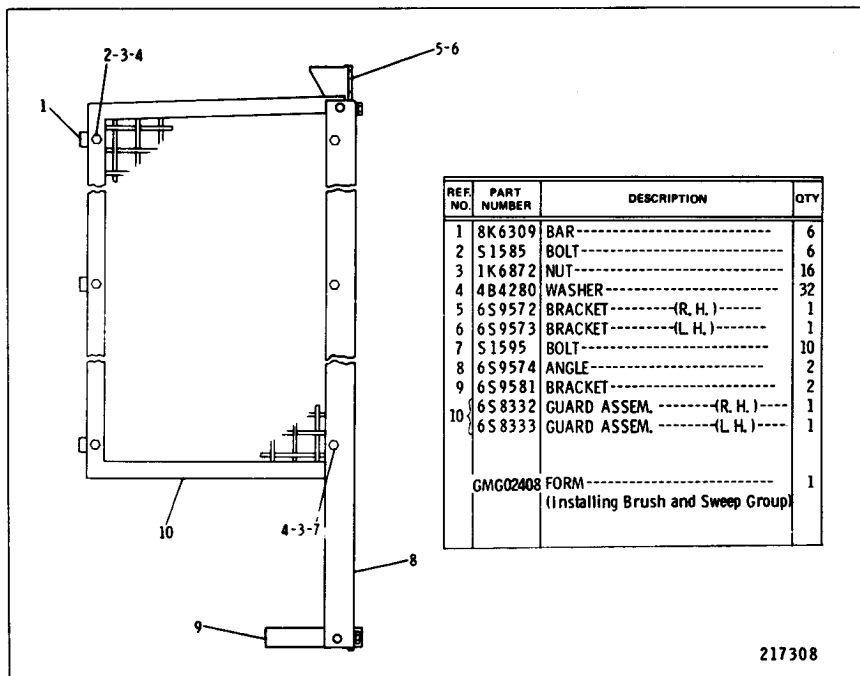

5G1176 BRUSH GUARD GROUP—Side  
FOR USE WITH 6S9286 SWEEP GROUP SHOWN ON PAGE 16D  
AN ATTACHMENT

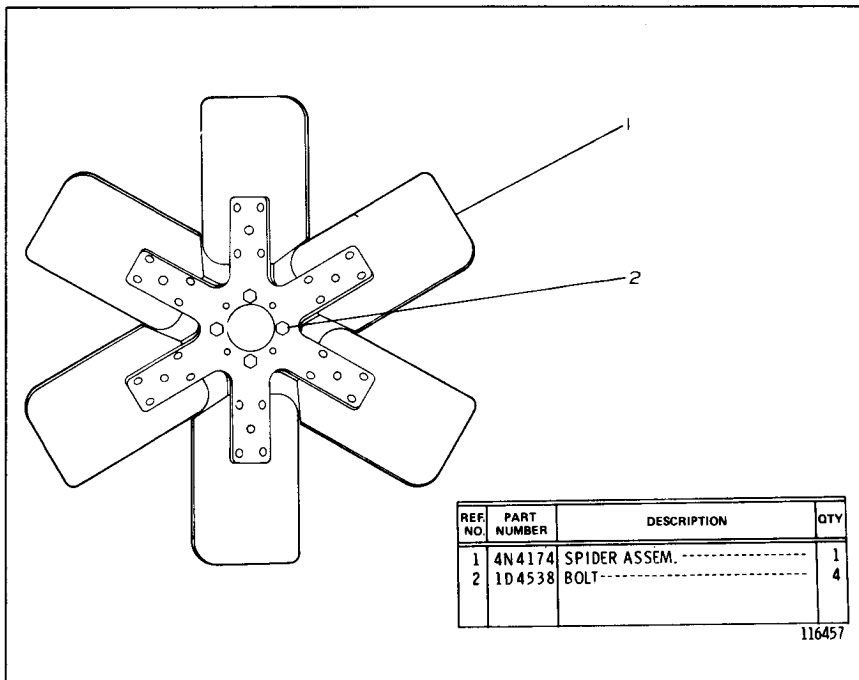

4N2220 SUCTION FAN GROUP—Type 1  
AN ATTACHMENT

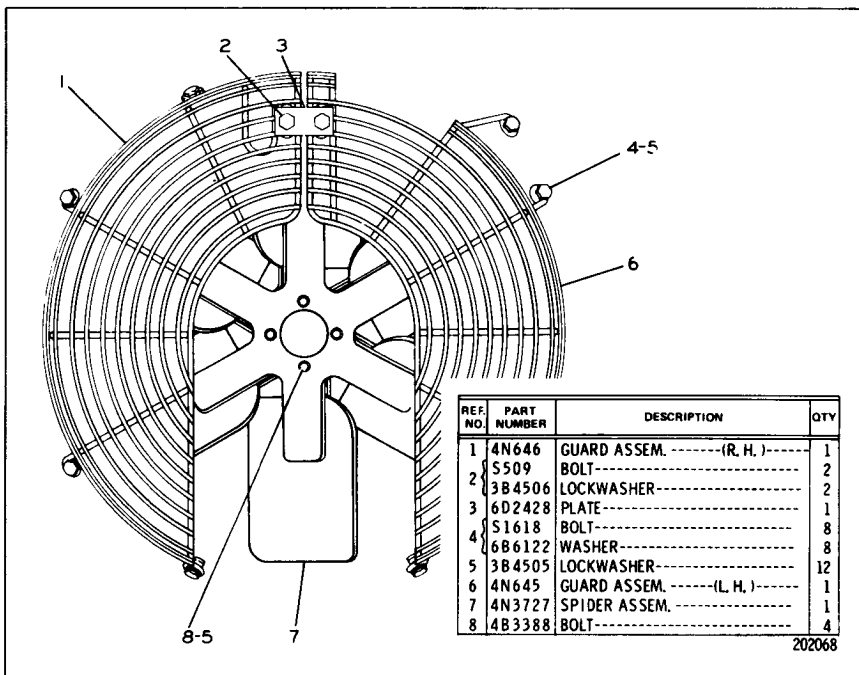

4N309 BLOWER FAN AND GUARD GROUP

Serial No. 79U1 to 673, 682, 685, 694, 719, 735 to 742, 744 and 79U1971 inclusive

REF. NO.	PART NUMBER	DESCRIPTION	QTY
C 1	6N52	GUARD ASSEM. -----(R. H.)----	1
		(Includes)	
	3P34	NUT-----	1
	S509	BOLT-----	2
2	3B4506	LOCKWASHER-----	2
3	6D2428	PLATE-----	1
	S1618	BOLT-----	8
4	6B6122	WASHER-----	8
5	3B4505	LOCKWASHER-----	12
C 6	6N51	GUARD ASSEM. -----(L. H.)----	1
		(Includes)	
	3P34	NUT-----	1
C 7	6N53	SPIDER ASSEM.-----	1
C 8	2B2694	BOLT-----	4

C INDICATES CHANGE 155216

4N309 BLOWER FAN AND GUARD GROUP  
 Serial No. 79U674 to 681, 683, 684, 686 to 693, 695 to 718,  
 720 to 734, 743, 745 to 1970 and 79U1972—Up

REF. NO.	PART NUMBER	DESCRIPTION	QTY
C 1	6N55	SPIDER ASSEM.-----	1
C 2	104541	BOLT-----	4

C INDICATES CHANGE 149274

4N2220 SUCTION FAN GROUP—Type 2  
 AN ATTACHMENT

CATERPILLAR D3 TRACTOR

REF. NO.	PART NUMBER	DESCRIPTION	QTY
C 1	8H2021	PRECLEANER-----	1
2	5P598	CLAMP-----	2
3	4N493	HOSE-----	1
C 4	4N7914	AIR CLEANER GROUP----- (Separate Illustration)	1

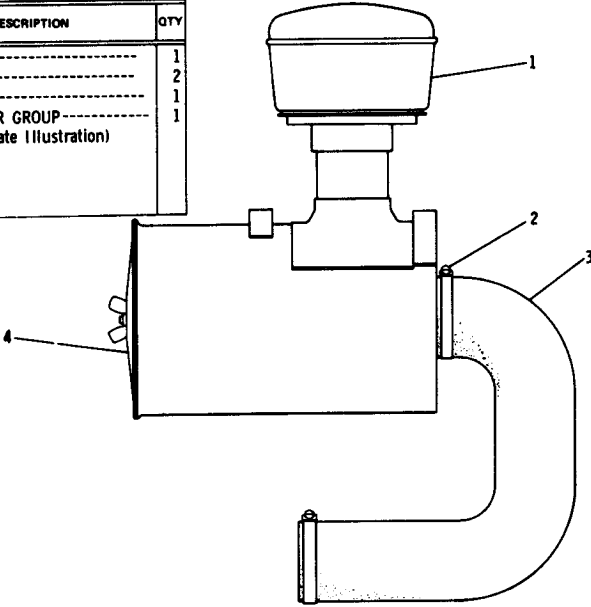

C INDICATES CHANGE

217162

4N307 AIR CLEANER GROUP

REF. NO.	PART NUMBER	DESCRIPTION	QTY
C 1	4N289	COVER ASSEM.-----	1
2	4N326	ELEMENT ASSEM.-----(primary)----	1
3	6N7675	NUT ASSEM.-----	2
4	4N313	ELEMENT ASSEM.-----(secondary)---	1

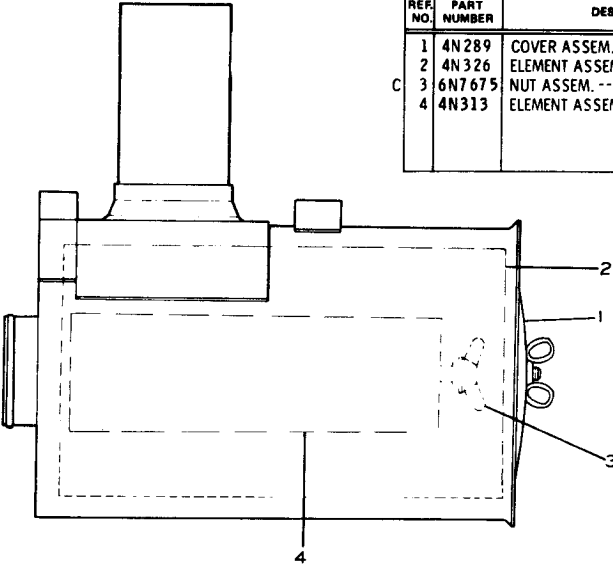

C INDICATES CHANGE

222832

4N7914 AIR CLEANER GROUP  
Part of 4N307 Air Cleaner Group

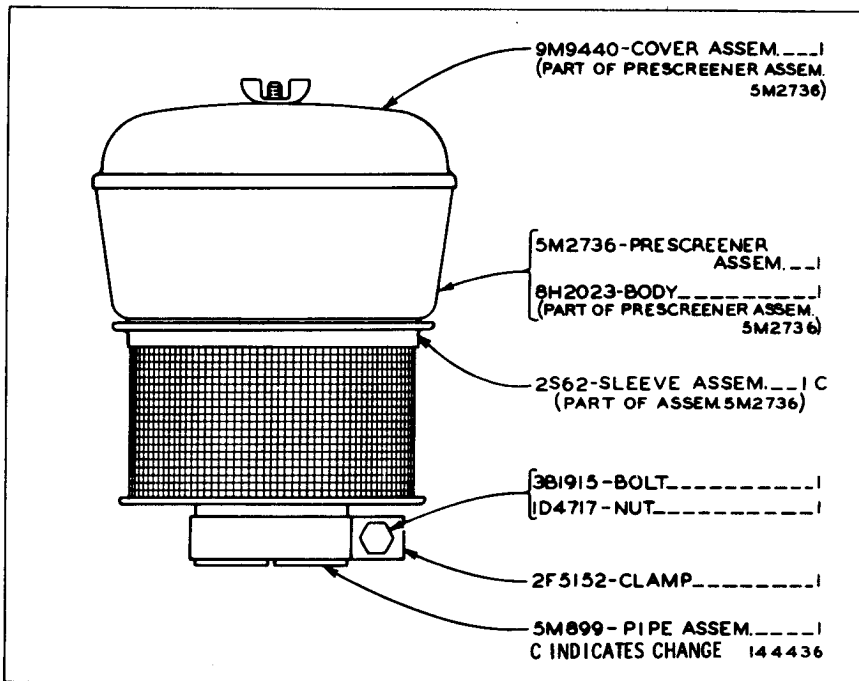

5M2735 PRESCREENER GROUP  
AN ATTACHMENT

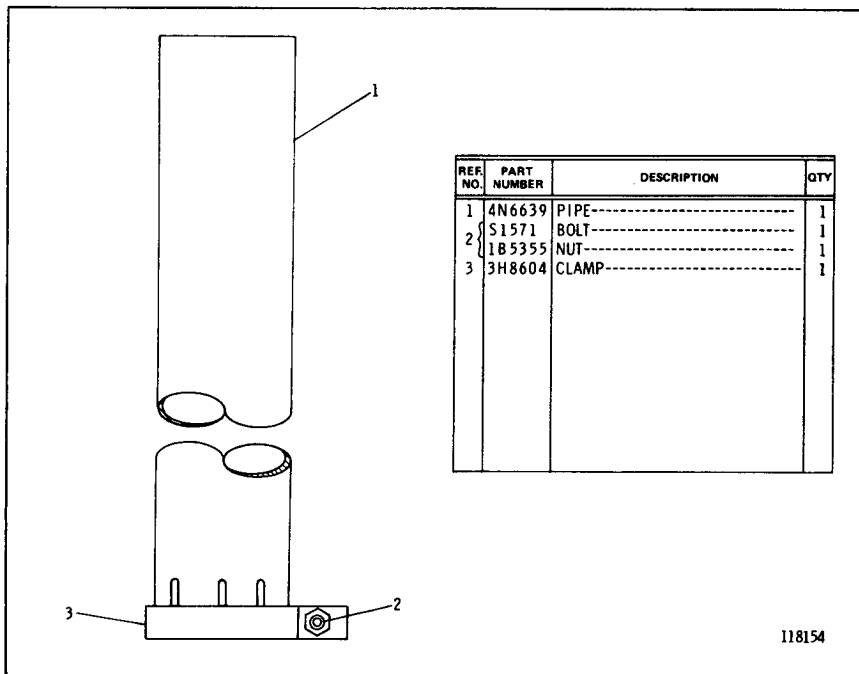

EXHAUST EXTENSION (4N312 N/S)

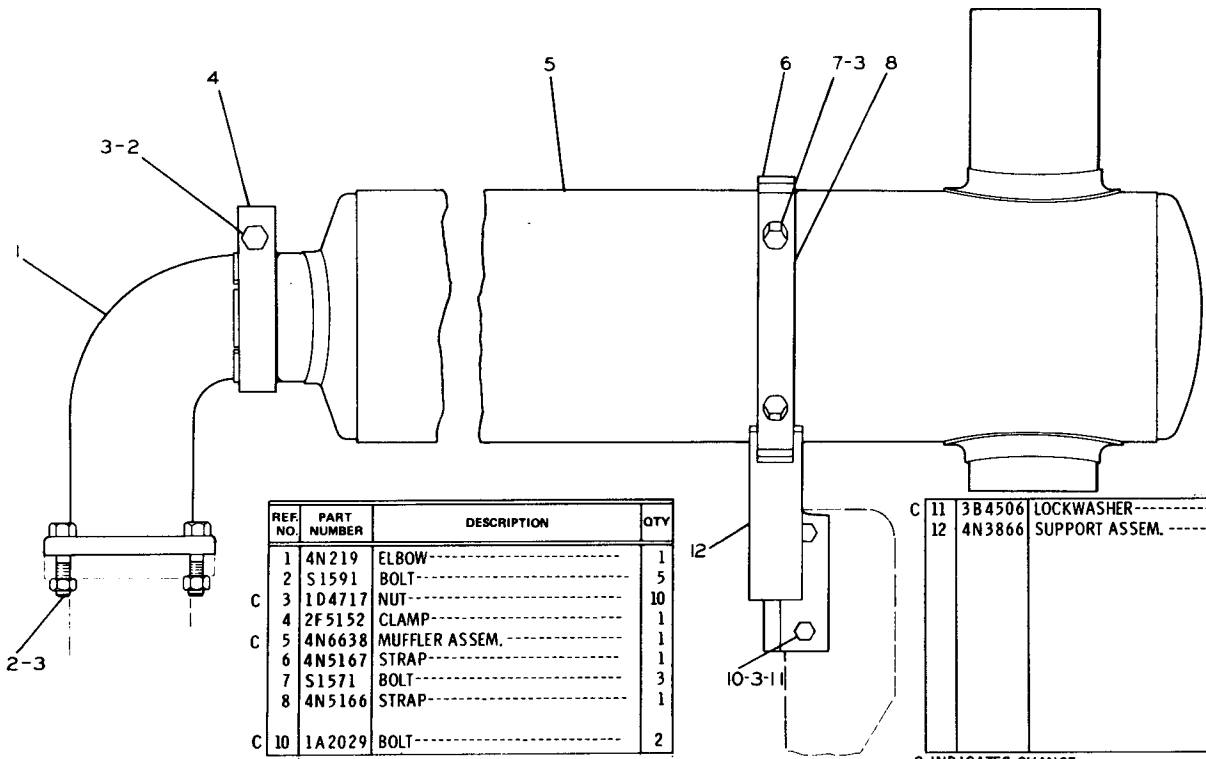

REF. NO.	PART NUMBER	DESCRIPTION	QTY
1	4N219	ELBOW	1
2	S1591	BOLT	5
C 3	1D4717	NUT	10
4	2F5152	CLAMP	1
C 5	4N6638	MUFFLER ASSEM.	1
6	4N5167	STRAP	1
7	S1571	BOLT	3
8	4N5166	STRAP	1
C 10	1A2029	BOLT	2

C 11	3B4506	LOCKWASHER	2
12	4N3866	SUPPORT ASSEM.	1

C INDICATES CHANGE

119634

4N310 MUFFLER GROUP  
 Serial No. 79U1 to 79U1706 inclusive



4N310 MUFFLER GROUP  
 Serial No. 79U1707 to 79U4384 inclusive

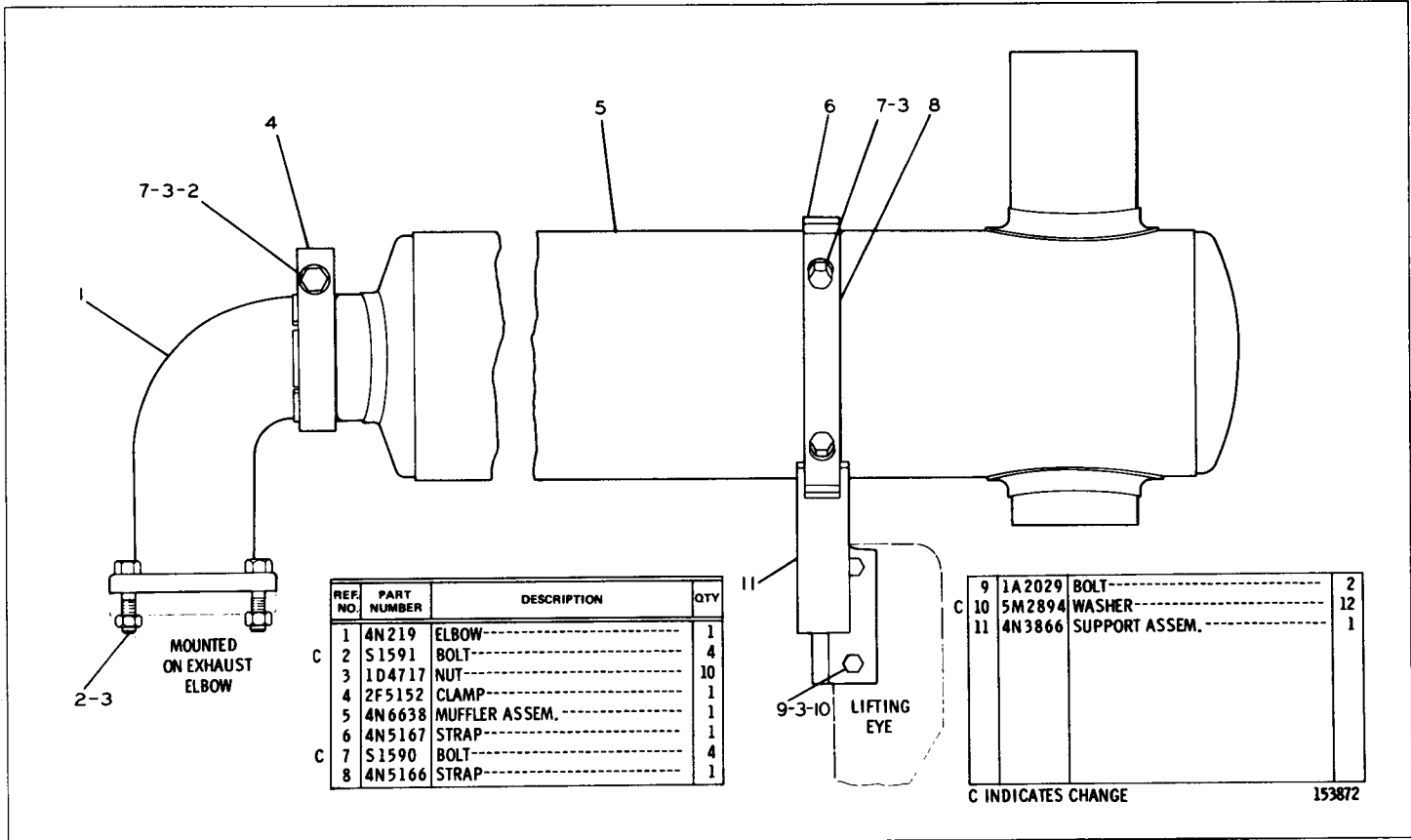

REF. NO.	PART NUMBER	DESCRIPTION	QTY
C 1	4N219	ELBOW-----	1
2	S1591	BOLT-----	4
3	1D4717	NUT-----	10
4	2F5152	CLAMP-----	1
5	4N6638	MUFFLER ASSEM.-----	1
6	4N5167	STRAP-----	1
C 7	S1590	BOLT-----	4
8	4N5166	STRAP-----	1

9	1A2029	BOLT-----	2
C 10	5M2894	WASHER-----	12
11	4N3866	SUPPORT ASSEM.-----	1

C INDICATES CHANGE

153872

4N310 MUFFLER GROUP  
Serial No. 79U4385—Up

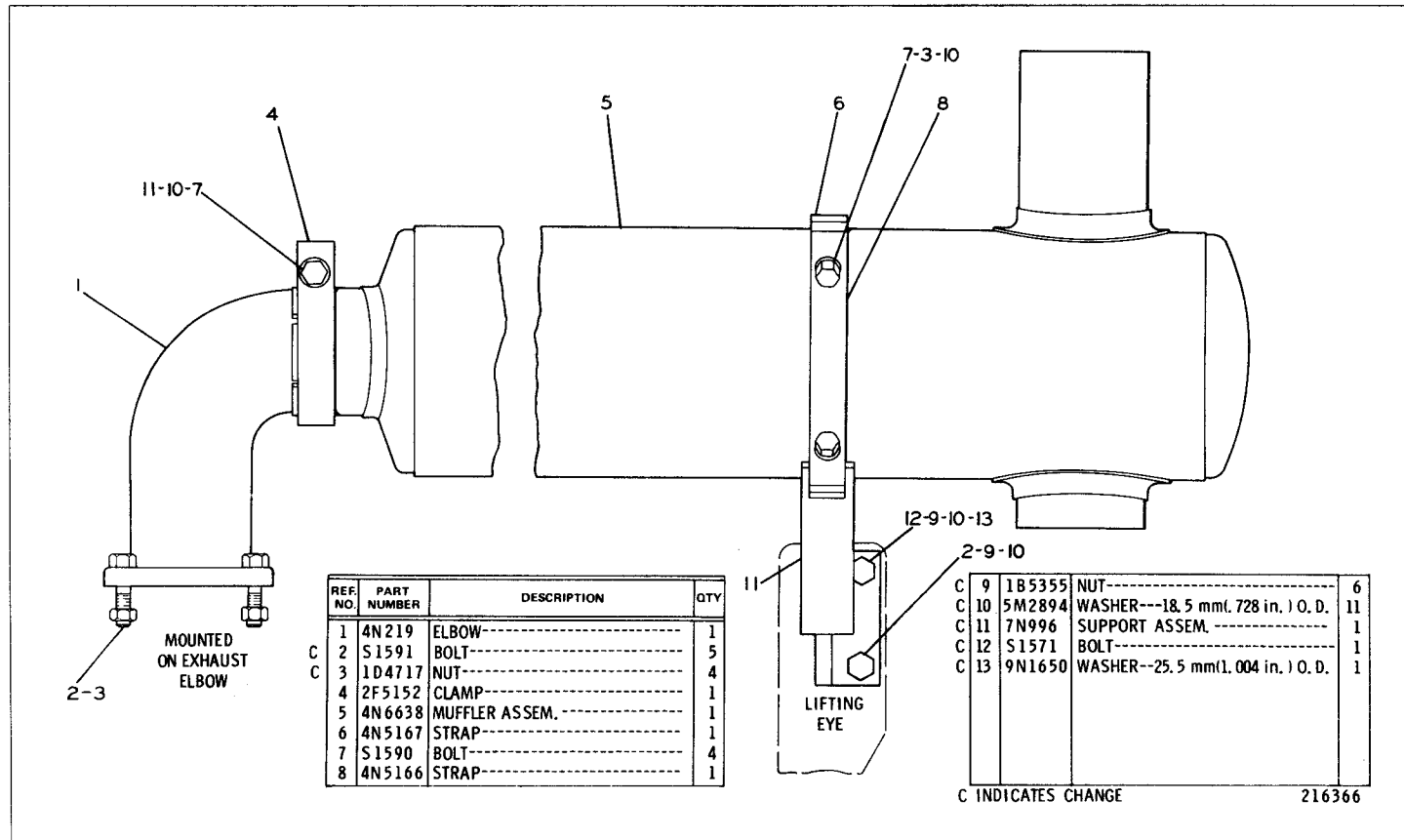

REF. NO.	PART NUMBER	DESCRIPTION	QTY
1	4N219	ELBOW-----	1
2	S1591	BOLT-----	5
3	1D4717	NUT-----	4
4	2F5152	CLAMP-----	1
5	4N6638	MUFFLER ASSEM.-----	1
6	4N5167	STRAP-----	1
7	S1590	BOLT-----	4
8	4N5166	STRAP-----	1

C 9	1B5355	NUT-----	6
C 10	5M2894	WASHER---18.5 mm(. 728 in. ) O. D.	11
C 11	7N996	SUPPORT ASSEM.-----	1
C 12	S1571	BOLT-----	1
C 13	9N1650	WASHER--25.5 mm(1. 004 in. ) O. D.	1

C INDICATES CHANGE

216366

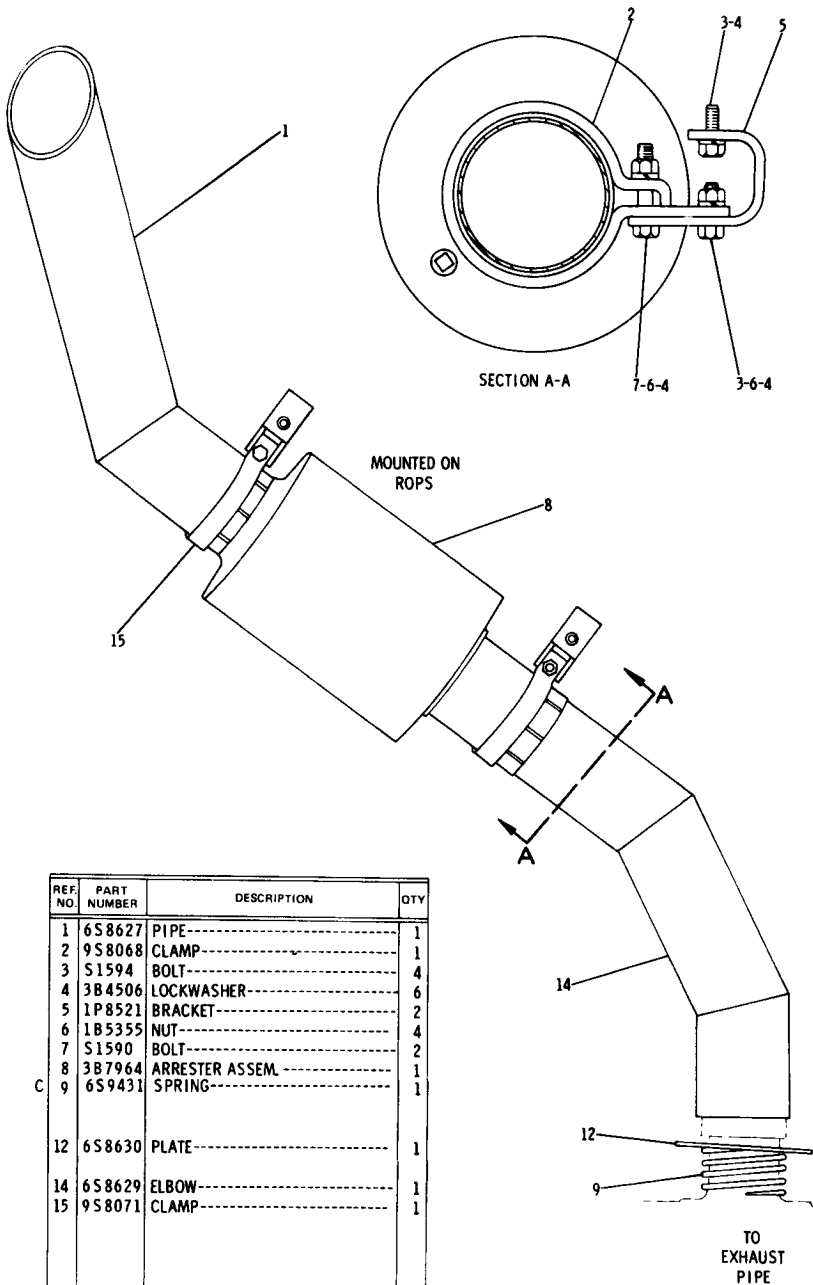

REF. NO.	PART NUMBER	DESCRIPTION	QTY
1	6S8627	PIPE-----	1
2	9S8068	CLAMP-----	1
3	S1594	BOLT-----	4
4	3B4506	LOCKWASHER-----	6
5	1P8521	BRACKET-----	2
6	1B5355	NUT-----	4
7	S1590	BOLT-----	2
8	3B7964	ARRESTER ASSEM.-----	1
C 9	6S9431	SPRING-----	1
12	6S8630	PLATE-----	1
14	6S8629	ELBOW-----	1
15	9S8071	CLAMP-----	1

C INDICATES CHANGE

161856

6S8636 SPARK ARRESTER GROUP  
 FOR USE WITH 6S8319 SWEEP GROUP SHOWN ON PAGE 16C  
 AN ATTACHMENT

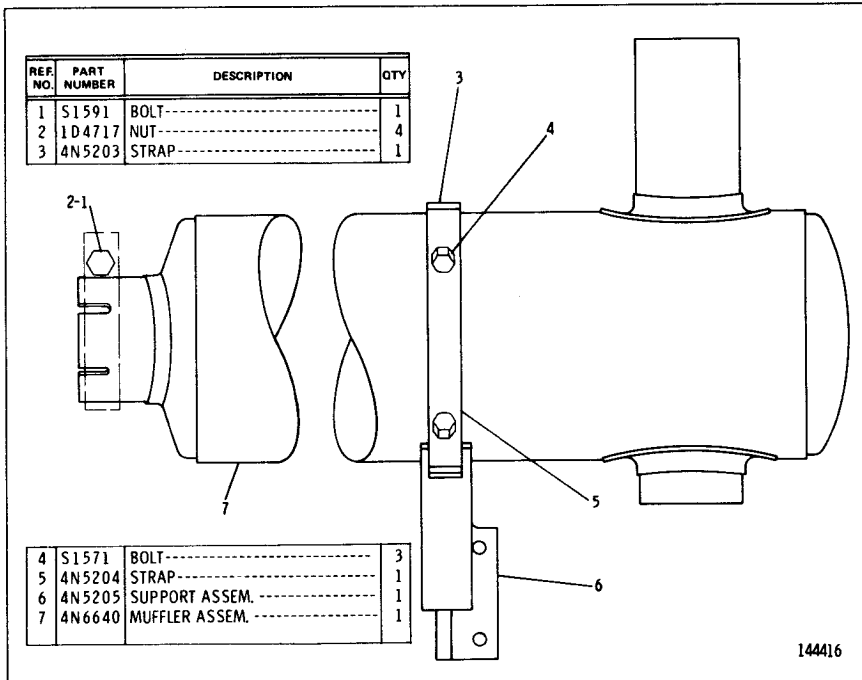

4N5202 MUFFLER GROUP—Type 1

Part of 6S8400 and 6S8500 Sound Suppression Arrangements listed on Page 88A

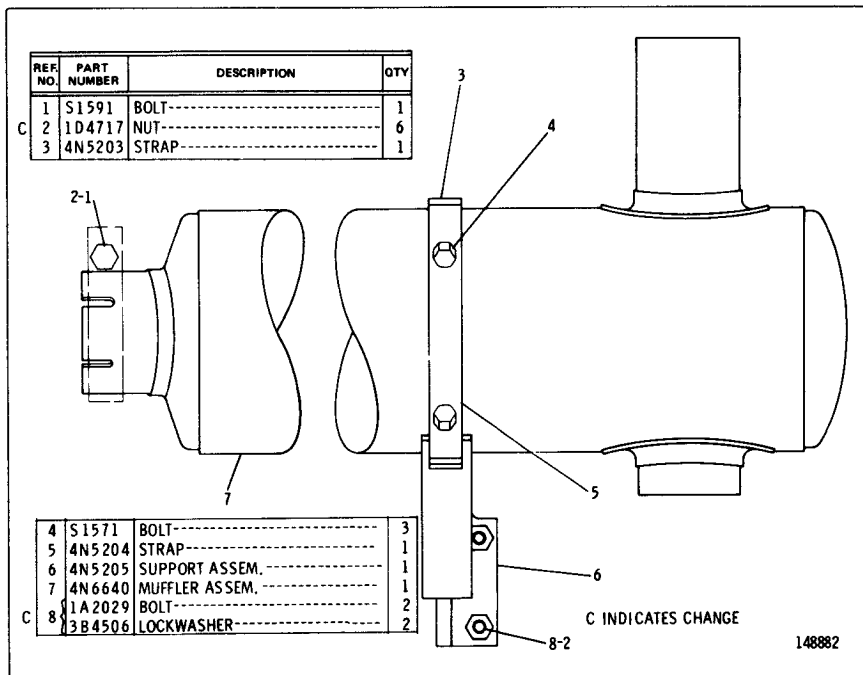

4N5202 MUFFLER GROUP—Type 2

Part of 6S8400 and 6S8500 Sound Suppression Arrangements listed on Page 88A

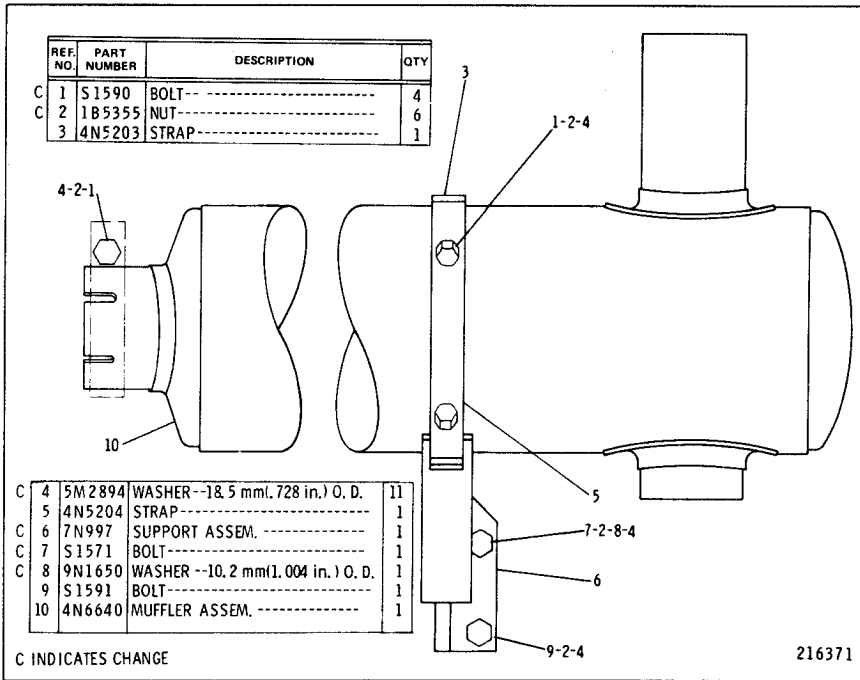

## 4N5202 MUFFLER GROUP—Type 3

Part of 6S8400 and 6S8500 Sound Suppression Arrangements listed on Page 88A

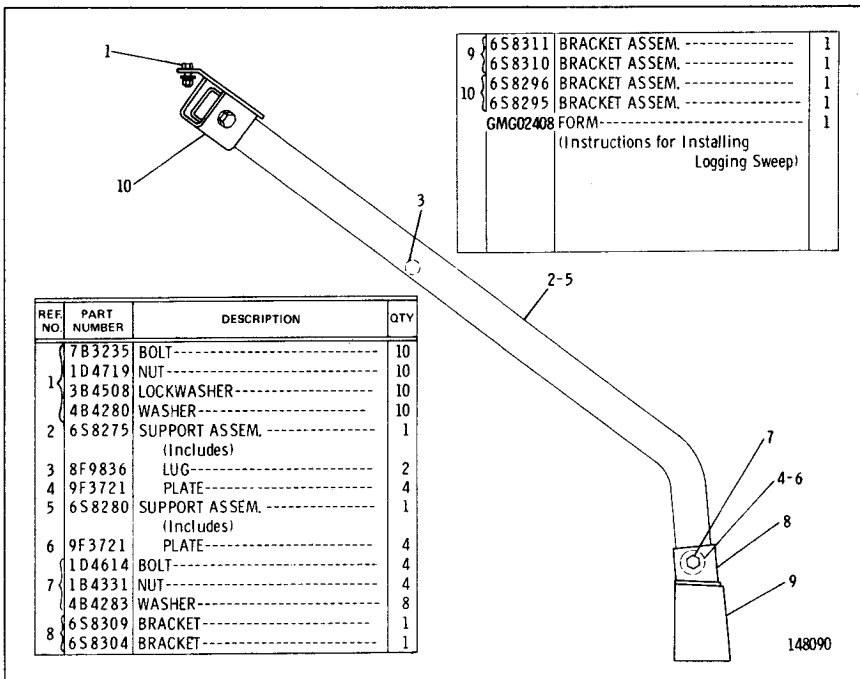

6S8319 SWEEP GROUP—Type 1  
AN ATTACHMENT

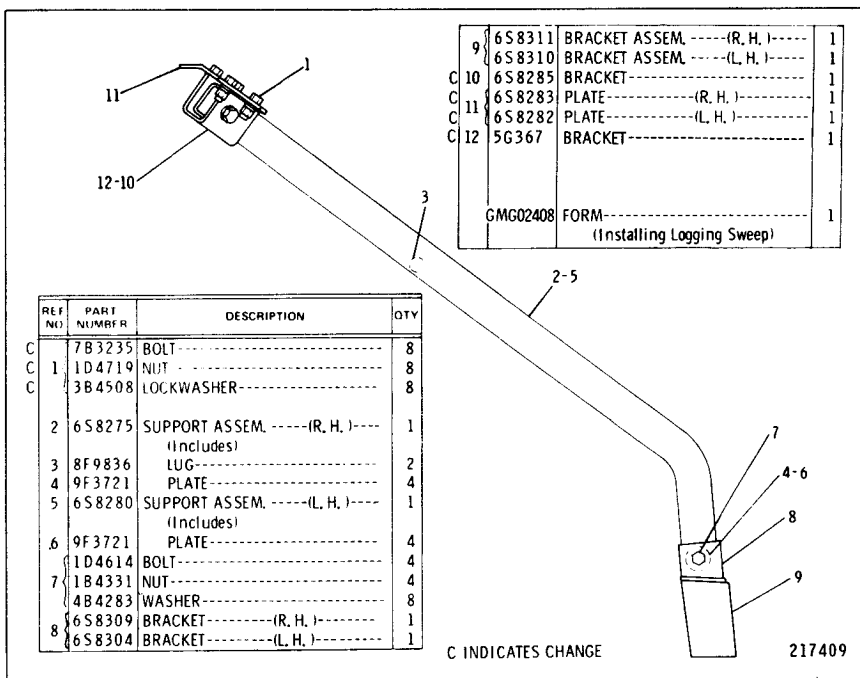

C INDICATES CHANGE

6S8319 SWEEP GROUP—Type 2  
AN ATTACHMENT

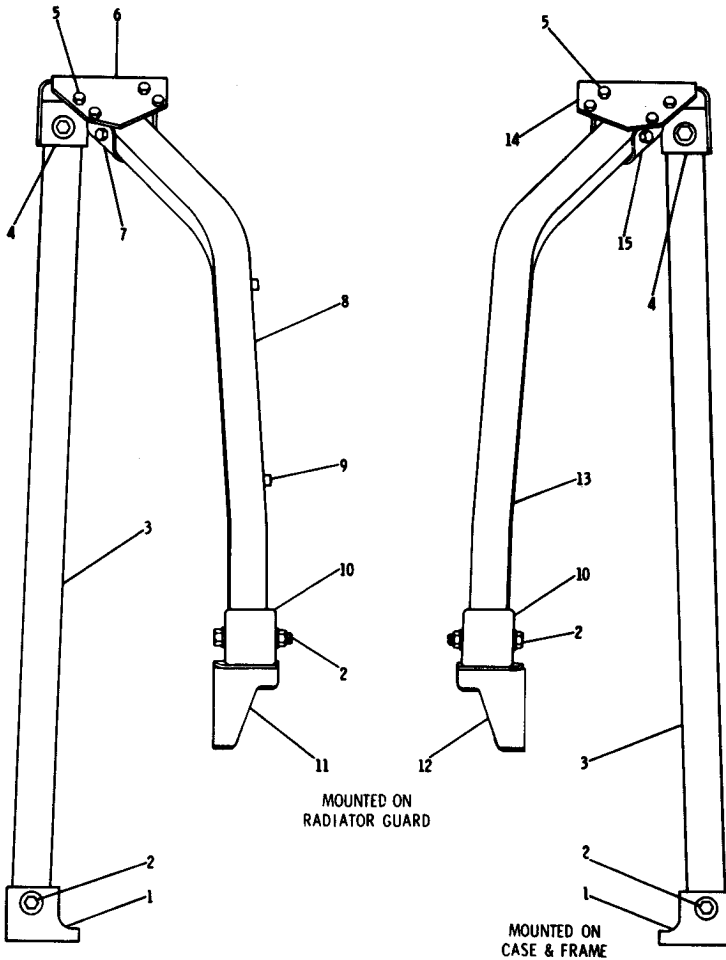

MOUNTED ON RADIATOR GUARD

MOUNTED ON CASE & FRAME

REF. NO.	PART NUMBER	DESCRIPTION	QTY
1	6S9015	BRACKET-----	2
1	1D4614	BOLT-----	8
	1B4331	NUT-----	8
2	4B4283	WASHER-----	16
	6S9030	SUPPORT ASSEM.-----	2
4	6S9023	BRACKET-----	2
5	7B3235	BOLT-----	8
	1D4719	NUT-----	8
6	3B4508	LOCKWASHER-----	8
	6S8282	PLATE----- (R. H.)-----	1
7	6S8285	BRACKET----- (R. H.)-----	1
8	6S8275	SUPPORT ASSEM.----- (R. H.)-----	1
	(Includes)		
9	9F3721	PLATE-----	4
	8F9836	LUG-----	2

10	6S8309	BRACKET-----	2
11	6S8311	BRACKET ASSEM.----- (R. H.)-----	1
12	6S8310	BRACKET ASSEM.----- (L. H.)-----	1
13	6S8280	SUPPORT ASSEM.----- (L. H.)-----	1
	(Includes)		
14	9F3721	PLATE-----	4
	6S8283	PLATE----- (L. H.)-----	1
15	5G367	BRACKET----- (L. H.)-----	1
GMG02408 FORM-----			1
(Installing logging & sweep)			

217309

6S9286 SWEEP GROUP AN ATTACHMENT

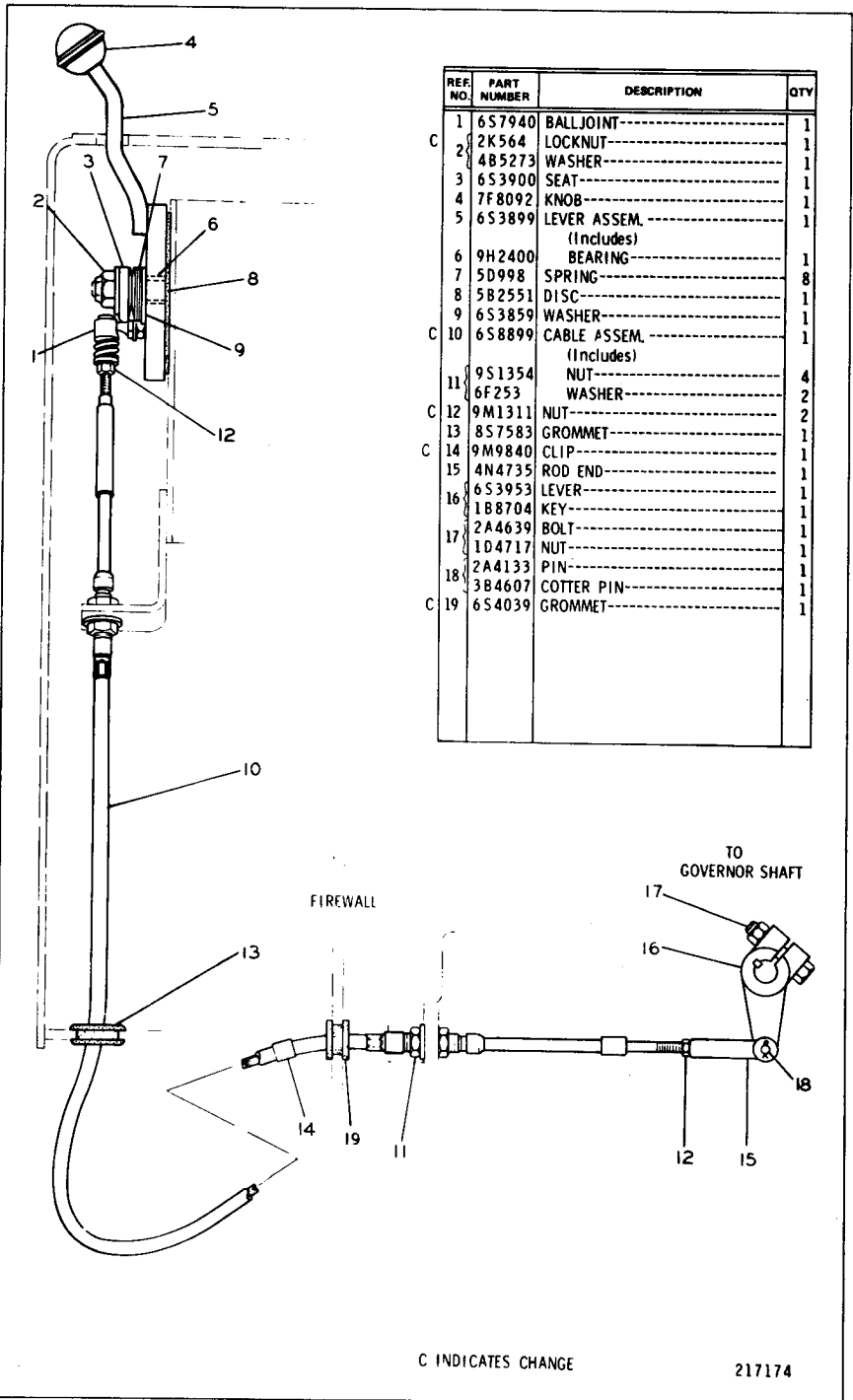

C INDICATES CHANGE

217174

6S3522 GOVERNOR CONTROL GROUP



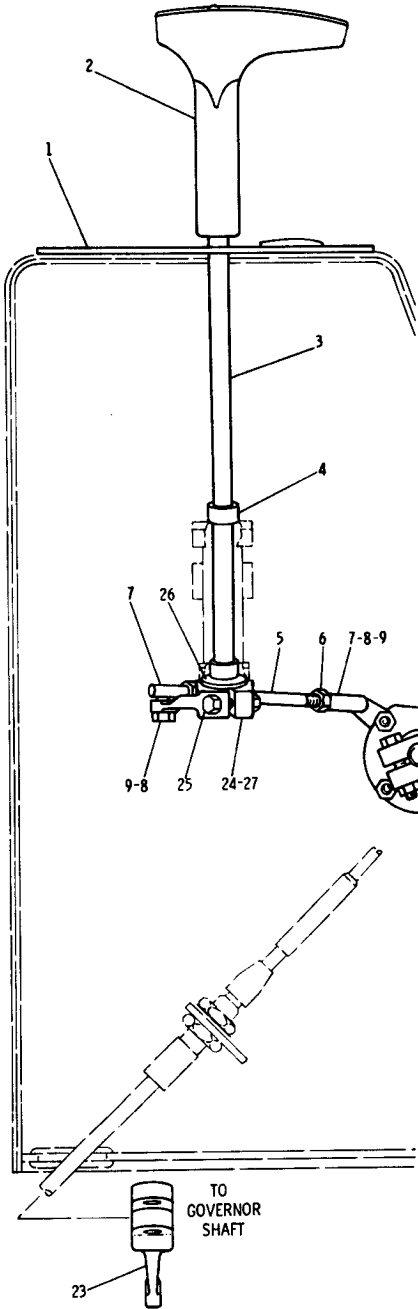

REF NO.	PART NUMBER	DESCRIPTION	QTY
1	6S7055	PLATE-----	1
C 1	5K3546	PLUG-----	1
2	3Y2088	HANDLE-----	1
C 2	3K1644	SCREW-----	1
C 3	6S7068	SHAFT ASSEM.-----	1
4	1B6182	(Includes) SPACER-----	1
5	6S7049	ROD-----	1
6	9M1311	NUT-----	2
7	9L2685	BALLJOINT-----	2
8	1B4201	NUT-----	2
9	3B4504	LOCKWASHER-----	6
10	6S7903	LEVER-----	1
11	2A4639	BOLT-----	2
	1D4717	NUT-----	2
12	8B2377	BOLT-----50.8 mm(2 in.) long	2
	1B2713	BOLT-----44.45 mm(1.75 in.) long	2
	1B4330	NUT-----	4
13	8H9182	ROLLER-----	1
	5H7152	SPRING-----	1
C 14	7M6955	GASKET-----	1
15	6S7721	LEVER-----	1
16	1B8704	KEY-----	2
C 17	5G1225	SUPPORT ASSEM.-----	1
	(Includes)		
18	5H7179	BEARING-----	2

19	6S7048	SHAFT ASSEM.-----	1
	(Includes)		
C 20	2S6079	KEY-----	1
	5G1227	RING-----	1
C 21	8H9180	SEAL-----	2
	3S2898	SHAFT ASSEM.-----	1
22	(Includes)		
	2S6091	DOWEL-----	2
23	6S7061	LEVER-----	1
24	1F552	LEVER-----	1
	9H2400	BEARING-----	1
25	1B7182	BOLT-----	1
	1D4716	NUT-----	1
26	4B4280	WASHER-----	1
27	1B8701	KEY-----	1

C INDICATES CHANGE

221358

6S701 GOVERNOR AND TRANSMISSION CONTROL GROUP  
AN ATTACHMENT

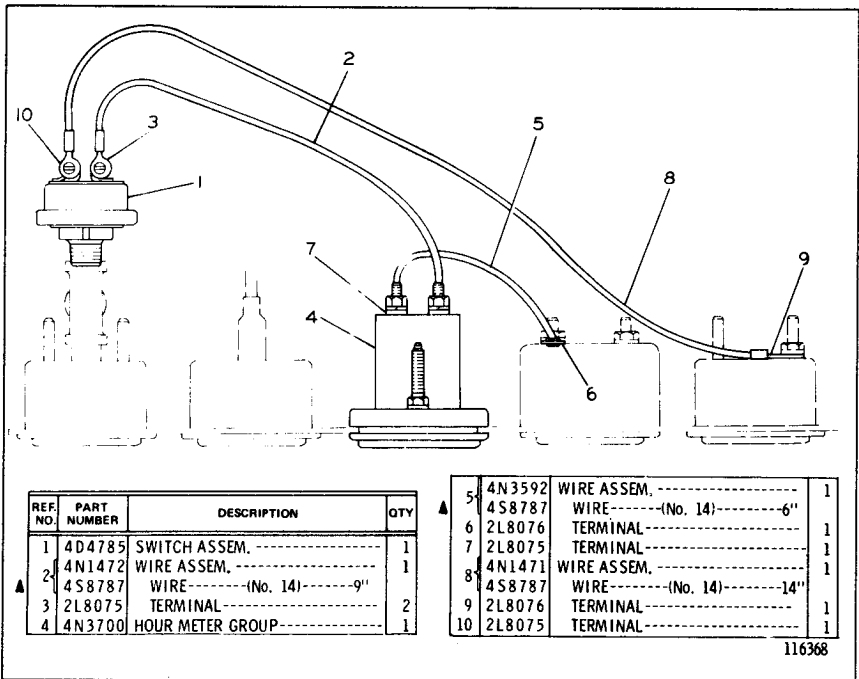

**4N481 ELECTRIC HOUR METER GROUP**  
Serial No. 79U1 to 79U2855 inclusive

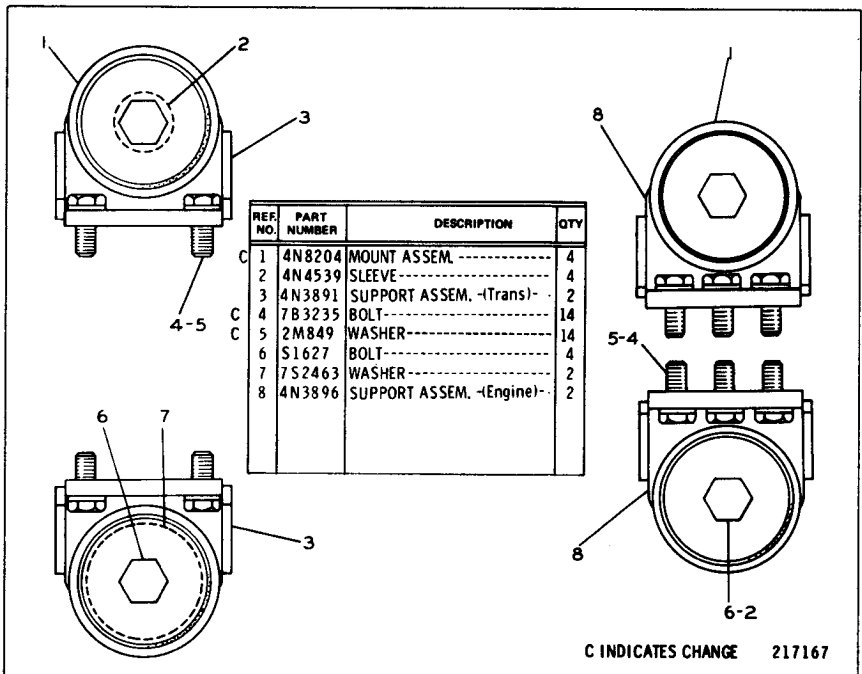

**4N300 ENGINE AND TRANSMISSION SUPPORT GROUP**

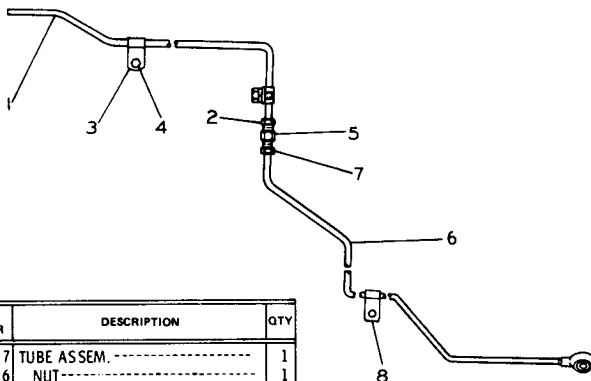

REF. NO.	PART NUMBER	DESCRIPTION	QTY
1	6S4157	TUBE ASSEM.-----	1
2	4B8756	NUT-----	1
3	7M8322	CLIP-----	1
4	T102	BOLT-----	1
4	3B4506	LOCKWASHER-----	1
5	5K9242	UNION-----	1
6	6S4175	TUBE ASSEM.-----	1
7	4B8756	NUT-----	1
C 8	3Y2348	CLIP-----	1

149302

FUEL LINES (6S3509 N/S)

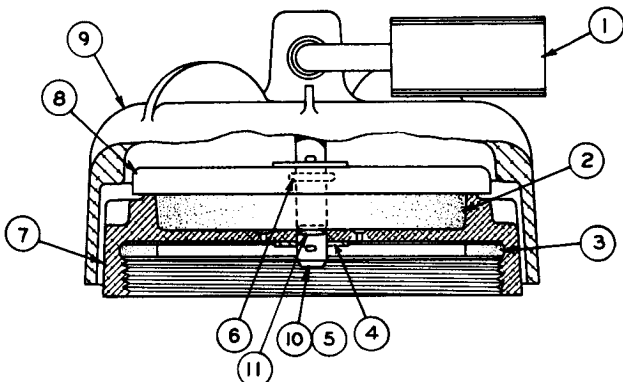

NOTE: FOR SERVICE OF PADLOCK AND KEY  
ORDER 857949 PADLOCK GROUP

▲ NOT PART OF 1P8678 CAP GROUP

REF. NO.	PART NUMBER	DESCRIPTION	QTY
▲ 1	Not Serv 8M439	PADLOCK----- KEY----- (Not Shown)	1 2
2	5S7657	FILTER-----	1
3	2A1763	GASKET-----	1
4	4J1105	SHIM-----	2

5	3B4605	COTTER PIN-----	2
6	5F9144	SEAL-----	1
7	1P8680	CAP-----	1
8	5S7646	LID-----	1
9	1P8050	COVER ASSEM.-----	1
9	1P8052	RETAINER-----	1
10	1P8679	PIN-----	1
11	8F9538	SEAL-----	1

111574

1P8678 PROTECTION COVER GROUP—Fuel Tank Cap  
Part of 6S8336, 6S3537 and 6S8476 Arrangements and 6S8340 Mounting  
Group shown on Pages 88F, 89, 90B and 96B

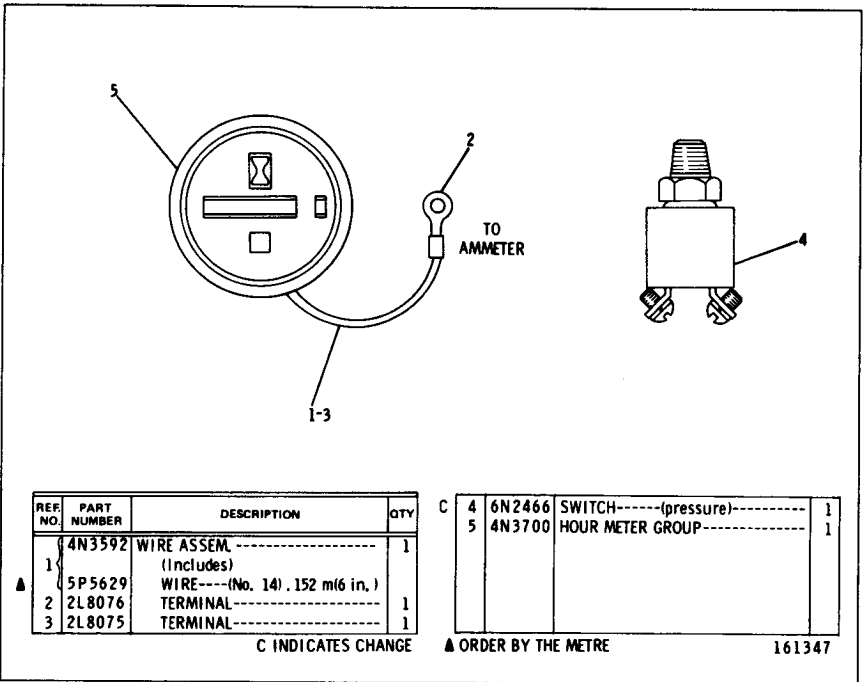

4N481 ELECTRIC HOUR METER GROUP  
Serial No. 79U2856—Up

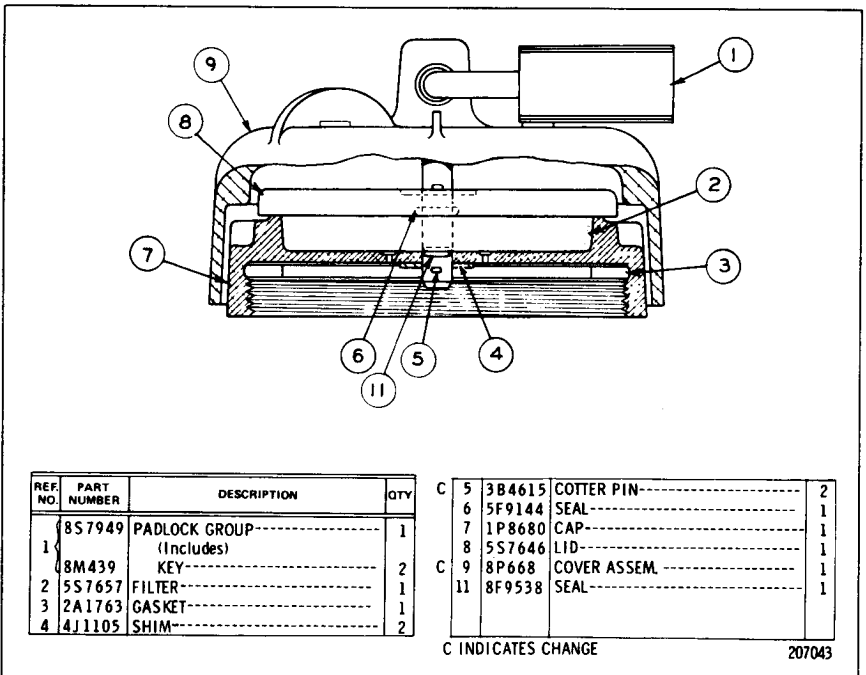

1P8678 PROTECTION COVER GROUP—Fuel Tank Cap—Type 2  
Part of 6S8336, 6S3537 and 6S8476 Arrangements and 6S8340 Mounting  
Group shown on Pages 88F, 89, 90B and 96B

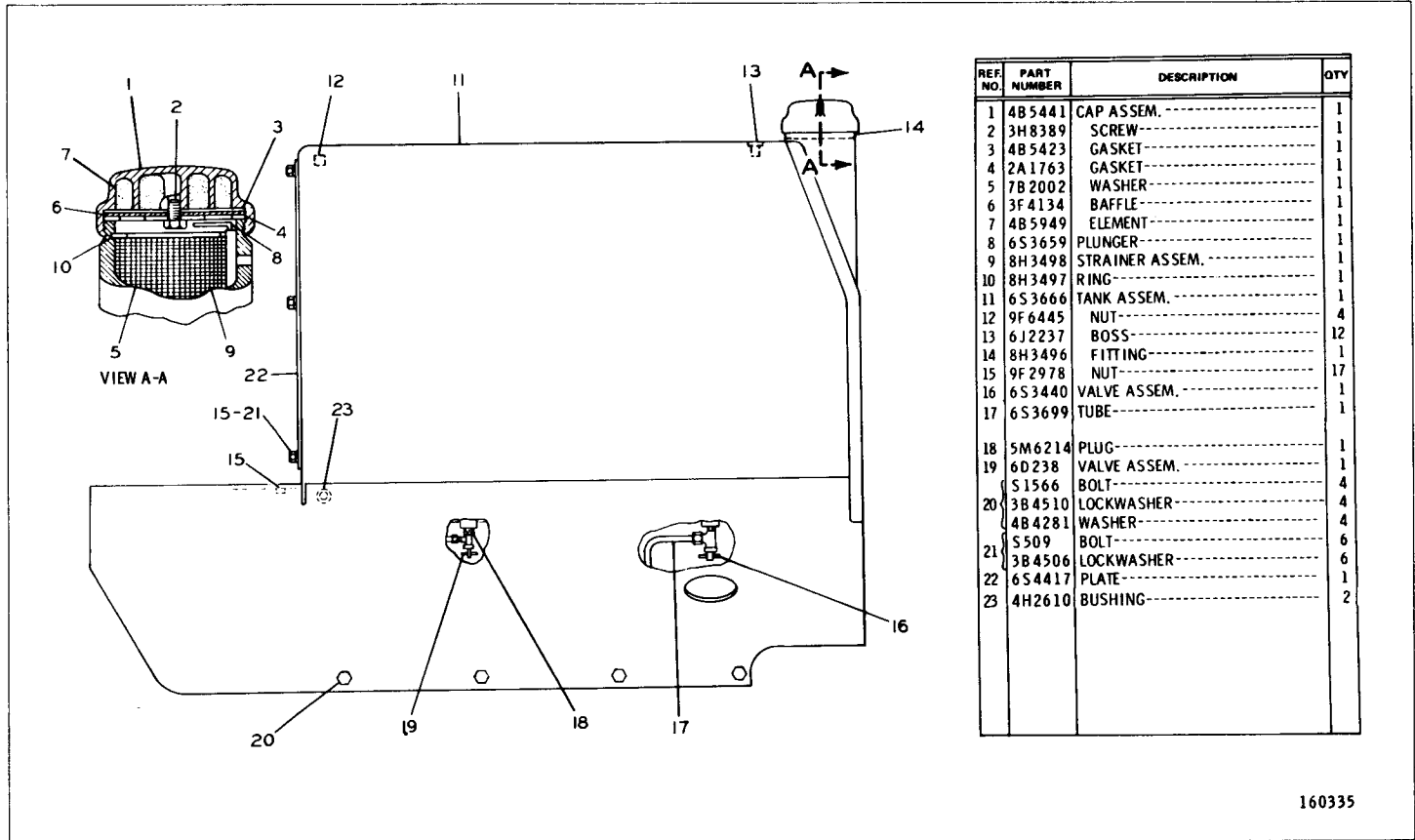

REF. NO.	PART NUMBER	DESCRIPTION	QTY
1	4B5441	CAP ASSEM. -----	1
2	3H8389	SCREW -----	1
3	4B5423	GASKET -----	1
4	2A1763	GASKET -----	1
5	7B2002	WASHER -----	1
6	3F4134	BAFFLE -----	1
7	4B5949	ELEMENT -----	1
8	6S3659	PLUNGER -----	1
9	8H3498	STRAINER ASSEM. -----	1
10	8H3497	RING -----	1
11	6S3666	TANK ASSEM. -----	1
12	9F6445	NUT -----	4
13	6J2237	BOSS -----	12
14	8H3496	FITTING -----	1
15	9F2978	NUT -----	17
16	6S3440	VALVE ASSEM. -----	1
17	6S3699	TUBE -----	1
18	5M6214	PLUG -----	1
19	6D238	VALVE ASSEM. -----	1
20	51566	BOLT -----	4
	3B4510	LOCKWASHER -----	4
	4B4281	WASHER -----	4
21	5509	BOLT -----	6
	3B4506	LOCKWASHER -----	6
22	6S4417	PLATE -----	1
23	4H2610	BUSHING -----	2

160335

6S3510 FUEL TANK GROUP—30 U. S. Gallon (114 litre)  
Serial No. 79U3011—Up

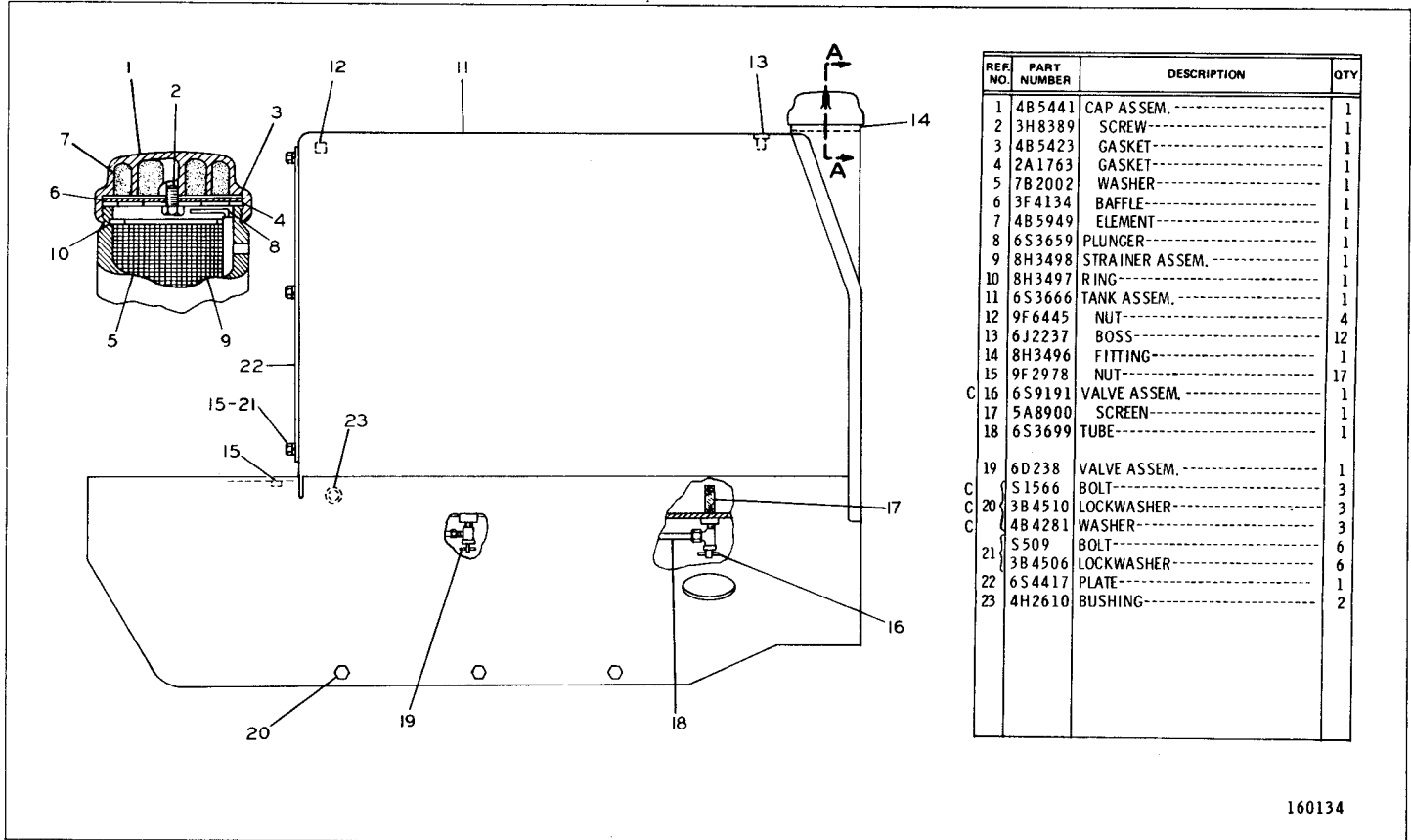

REF. NO.	PART NUMBER	DESCRIPTION	QTY
1	4B 5441	CAP ASSEM.-----	1
2	3H 8389	SCREW-----	1
3	4B 5423	GASKET-----	1
4	2A 1763	GASKET-----	1
5	7B 2002	WASHER-----	1
6	3F 4134	BAFFLE-----	1
7	4B 5949	ELEMENT-----	1
8	6S 3659	PLUNGER-----	1
9	8H 3498	STRAINER ASSEM.-----	1
10	8H 3497	RING-----	1
11	6S 3666	TANK ASSEM.-----	1
12	9F 6445	NUT-----	4
13	6J 2237	BOSS-----	12
14	8H 3496	FITTING-----	1
15	9F 2978	NUT-----	17
C 16	6S 9191	VALVE ASSEM.-----	1
17	5A 8900	SCREEN-----	1
18	6S 3699	TUBE-----	1
19	6D 238	VALVE ASSEM.-----	1
C 20	S 1566	BOLT-----	3
C 20	3B 4510	LOCKWASHER-----	3
C 20	4B 4281	WASHER-----	3
21	S 509	BOLT-----	6
21	3B 4506	LOCKWASHER-----	6
22	6S 4417	PLATE-----	1
23	4H 2610	BUSHING-----	2

160134

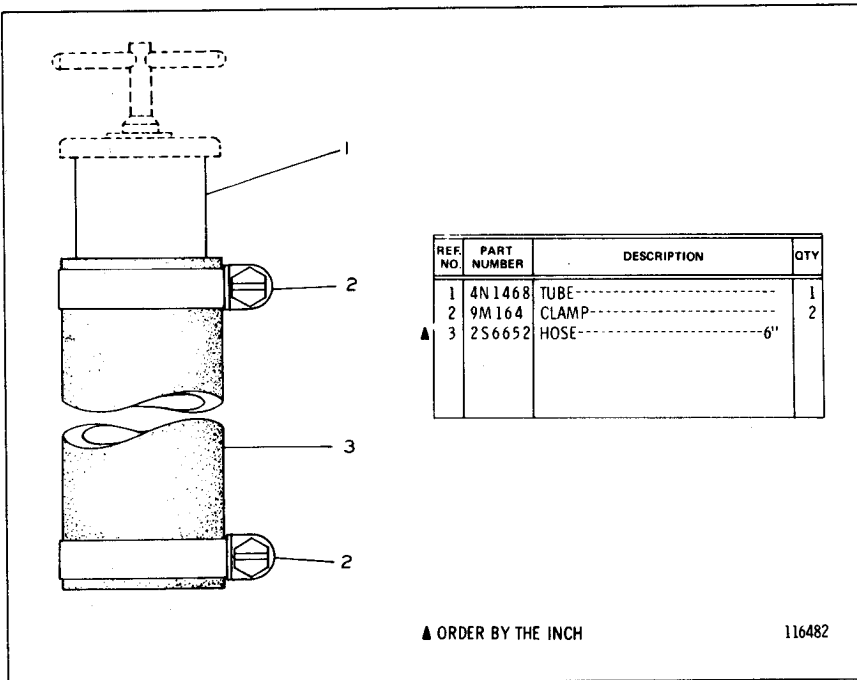

4N328 OIL FILLER EXTENSION GROUP

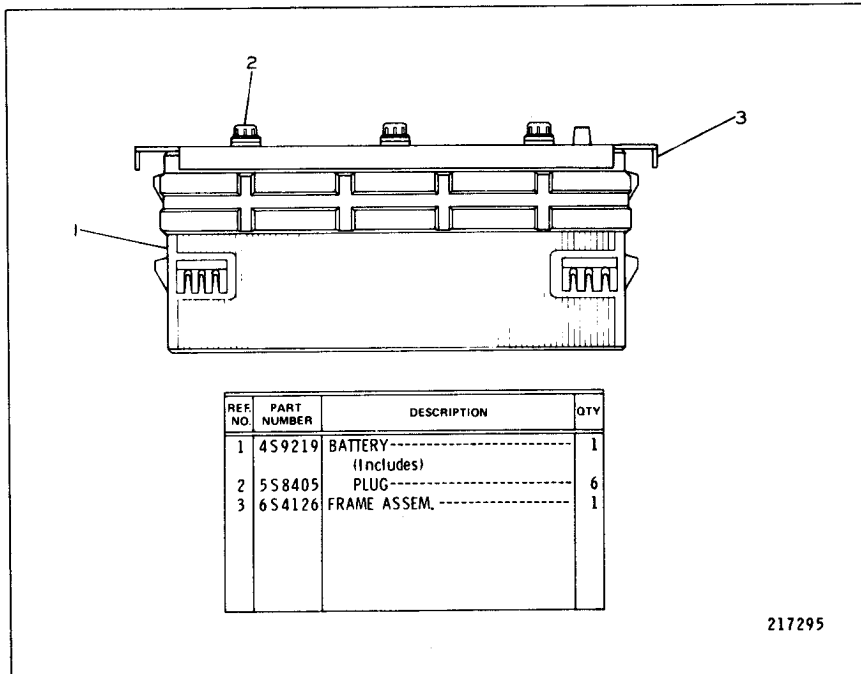
6S3548 BATTERY GROUP—Heavy Duty  
AN ATTACHMENT

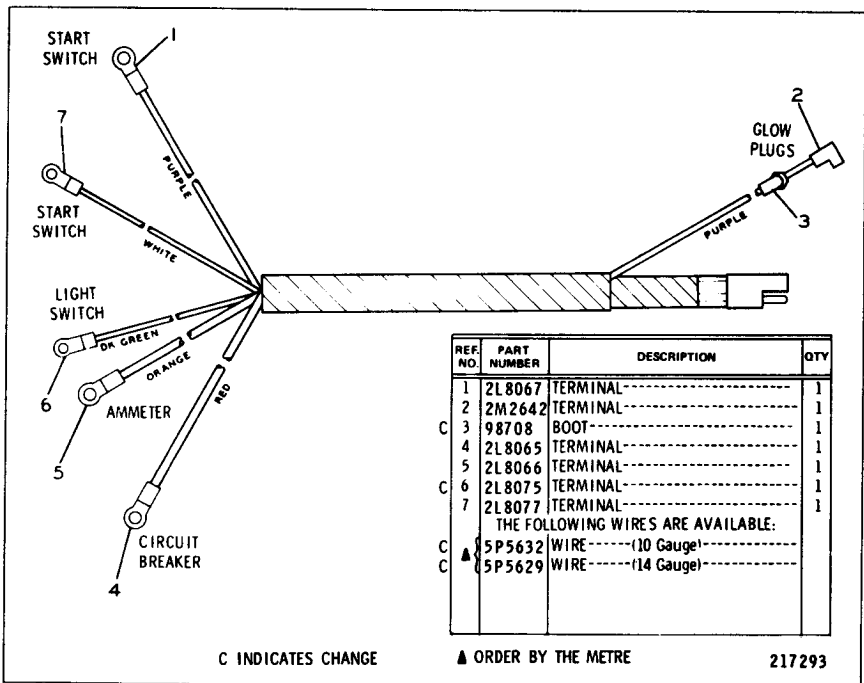

6S4381 WIRING HARNESS ASSEMBLY  
Part of 6S3514 Battery and Wiring Group shown on Page 25

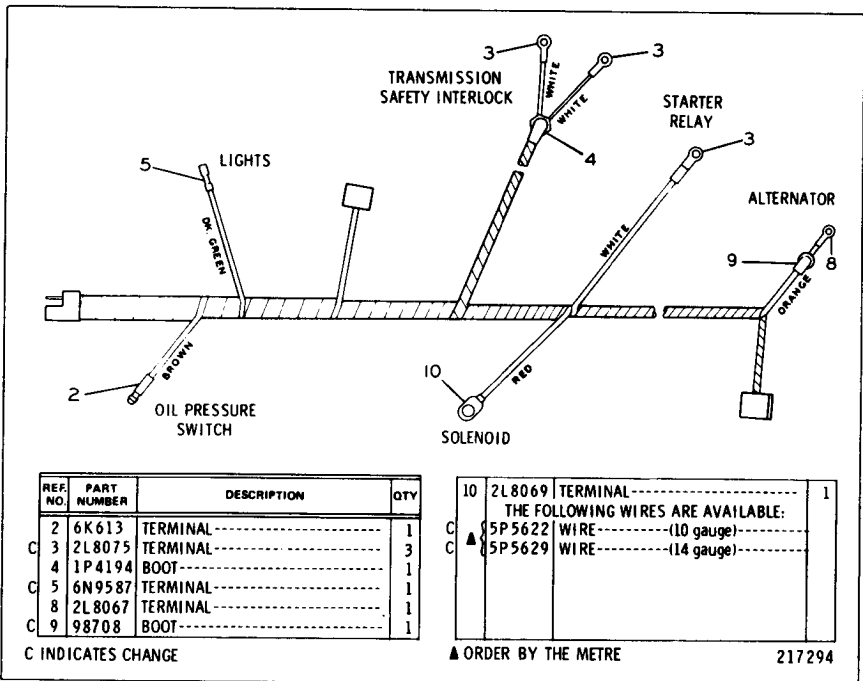

6S4382 WIRING HARNESS ASSEMBLY  
Part of 6S3514 Battery and Wiring Group shown on Page 24



REF. NO.	PART NUMBER	DESCRIPTION	QTY
1	4M1111	MAT-----	1
	6K4355	ROD-----	4
	1B4330	NUT-----	4
2	3B4607	COTTER PIN-----	4
	3B4504	LOCKWASHER-----	6
	4B4276	WASHER-----	4
3	4K6697	HOLD DOWN ASSEM.-----	1
4	3H2900	GROMMET-----	1
	5H3631	CABLE ASSEM.-----	1
5	1S7252	TERMINAL-----	1
	5M9205	TERMINAL ASSEM.-----	1
6	1M6119	BOLT-----	1
	1M6120	NUT-----	1

C	7	8M2770	CLIP-----	2
	8	6S4382	HARNES ASSEM.----- (Separate Illustration)	1

	9	4N5110	REGULATOR ASSEM.-----	1
		5S1614	BOLT-----	2
		6S4302	CABLE ASSEM.-----	1
● C	10	5P746	CABLE-----29 cm(11.25 in.)	1
		1S7252	TERMINAL-----	2
	11	4S9261	BATTERY-----	1
	12	7S5041	PLUG-----	6
	13	5K3294	CLIP-----	1
C		3F1685	CABLE ASSEM.-----	1
	14	4S8769	CABLE-----87 in.	1
		1S7252	TERMINAL-----	1
	15	5M9204	TERMINAL ASSEM.-----	1
	16	1M6119	BOLT-----	1
		1M6120	NUT-----	1
C	17	T102	BOLT-----	2
C	18	3B4506	LOCKWASHER-----	3
C		2H3755	BOLT-----	1
C	19	3B4505	LOCKWASHER-----	1
C	20	3S2093	STRAP-----	1
C	21	4B4123	CLIP-----	2
C		3B1915	BOLT-----	1
C	22	2B941	BOSS-----	1

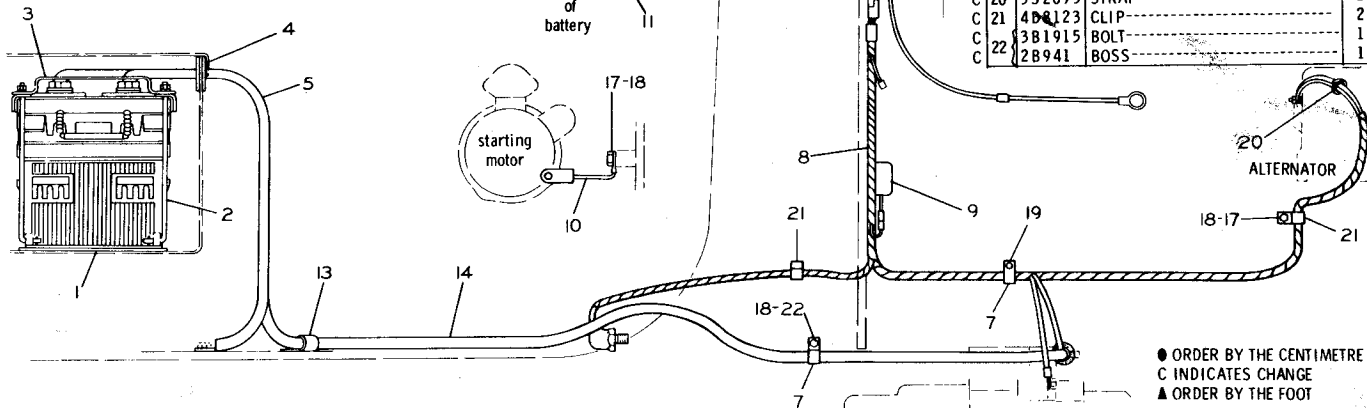

148866

6S3514 BATTERY AND WIRING GROUP—12 Volt—Part 1  
Serial No. 79U1 to 79U2273 inclusive  
6S4382 Harness parts are shown on Page 23

6S3514 BATTERY AND WIRING GROUP—12 Volt—Part 2  
 Serial No. 79U1 to 79U2273 inclusive  
 6S4381 Harness parts are shown on Page 23

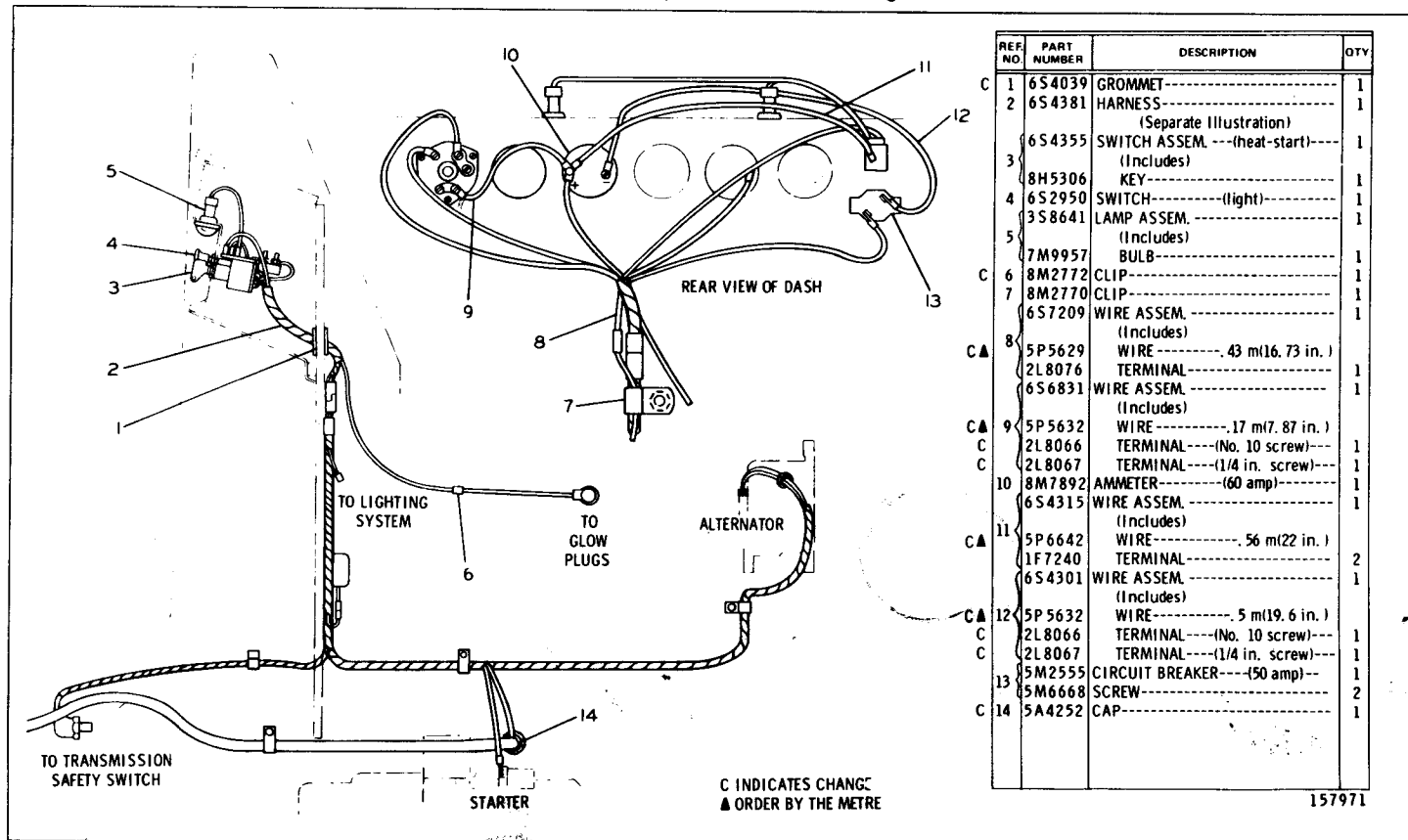

REF NO.	PART NUMBER	DESCRIPTION	QTY
C 1	6S4039	GROMMET-----	1
2	6S4381	HARNESSES----- (Separate Illustration)	1
	6S4355	SWITCH ASSEM. ---(heat-start)---	1
3		(Includes)	
	8H5306	KEY-----	1
4	6S2950	SWITCH----- (light)-----	1
	3S8641	LAMP ASSEM.-----	1
5		(Includes)	
	7M9957	BULB-----	1
C 6	8M2772	CLIP-----	1
7	8M2770	CLIP-----	1
	6S7209	WIRE ASSEM.----- (Includes)	1
C ▲ 8	5P5629	WIRE ----- .43 m(16.73 in.)	
	2L8076	TERMINAL-----	1
	6S6831	WIRE ASSEM.----- (Includes)	1
C ▲ 9	5P5632	WIRE ----- .17 m(7.87 in.)	
	2L8066	TERMINAL-----(No. 10 screw)---	1
C	2L8067	TERMINAL-----(1/4 in. screw)---	1
10	8M7892	AMMETER----- (60 amp)-----	1
	6S4315	WIRE ASSEM.----- (Includes)	1
C ▲ 11	5P6642	WIRE ----- .56 m(22 in.)	
	1F7240	TERMINAL-----	2
	6S4301	WIRE ASSEM.----- (Includes)	1
C ▲ 12	5P5632	WIRE ----- .5 m(19.6 in.)	
C	2L8066	TERMINAL-----(No. 10 screw)---	1
C	2L8067	TERMINAL-----(1/4 in. screw)---	1
13	5M2555	CIRCUIT BREAKER---(50 amp)---	1
	5M6668	SCREW-----	2
C 14	5A4252	CAP-----	1

157971

REF. NO.	PART NUMBER	DESCRIPTION	QTY
1	4M1111	MAT-----	1
	6K4355	ROD-----	4
	1B4330	NUT-----	4
2	3B4607	COTTER PIN-----	4
	3B4504	LOCKWASHER-----	4
	4B4276	WASHER-----	4
	4K6697	HOLD DOWN ASSEM.-----	1
4	3H2900	GROMMET-----	1
	5H3631	CABLE ASSEM.-----	1
5	1S7252	TERMINAL----- (ground)	1
	5M9205	TERMINAL ASSEM.-----	1
6	1M6119	BOLT-----	1
	1M6120	NUT-----	1
7	3B1915	BOLT-----	1
	2B941	BOSS-----	1

4	4N5110	REGULATOR ASSEM.-----	1
8	51614	BOLT-----	2
	3B4607	LOCKWASHER-----	2
9	6S4382	HARNES ASSEM.-----	1
		(Separate Illustration)	

	6S4302	CABLE ASSEM.-----	1
C 10	5P746	CABLE-----29 cm(11.25 in.)	1
	1S7252	TERMINAL-----	2
11	4S9262	BATTERY-----	1
12	7S5041	PLUG-----	6
13	5K3294	CLIP-----	1
C	3F1685	CABLE ASSEM.-----	1
▲ 14	5P746	CABLE-----221 cm(87 in.)	1
	1S7252	TERMINAL-----	1
15	5M9204	TERMINAL ASSEM.-----	1
	1M6119	BOLT-----	1
16	1M6120	NUT-----	1
C 17	T102	BOLT-----	1
C 18	3B4506	LOCKWASHER-----	2
	2H3755	BOLT-----	1
19	3B4505	LOCKWASHER-----	1
	3S2093	STRAP-----	1
C 21	8M2770	CLIP-----	4
C 22	4B4278	WASHER-----	2

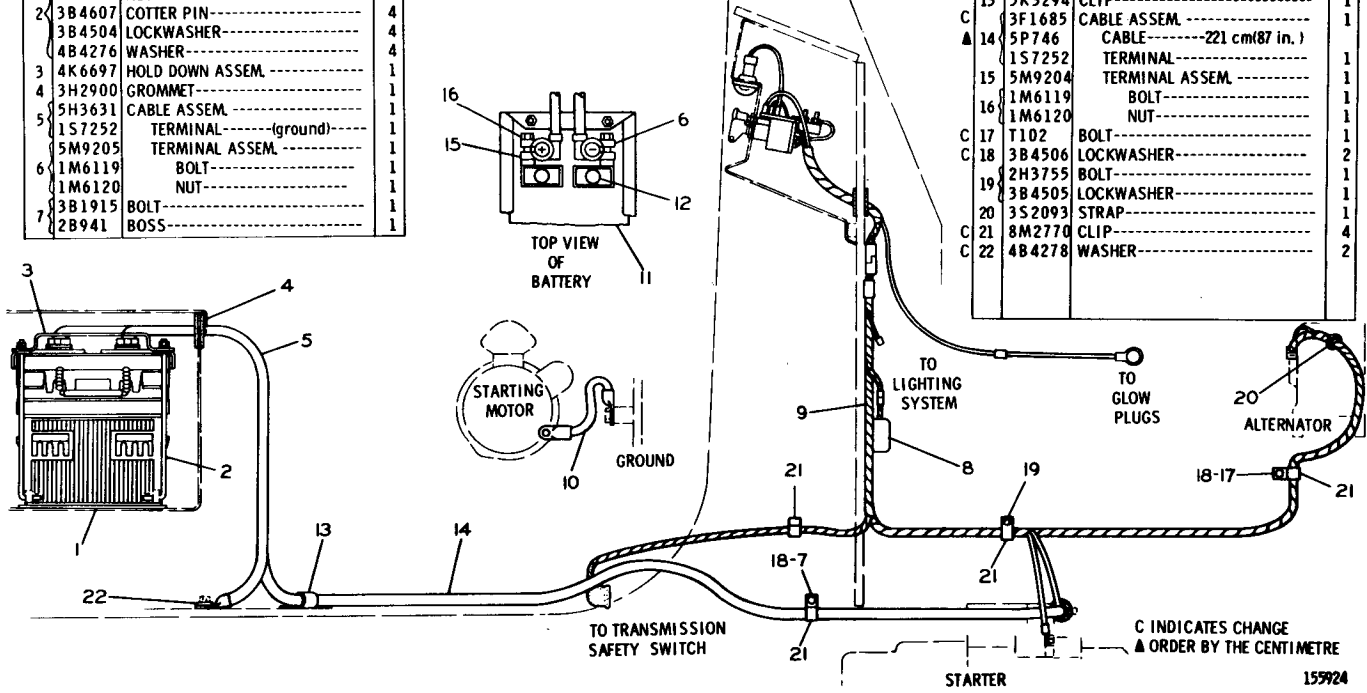

6S3514 BATTERY AND WIRING GROUP—12 Volt—Part 1  
 Serial No. 79U2274 to 79U2855 inclusive  
 6S4382 Harness parts are shown on Page 23

159924

6S3514 BATTERY AND WIRING GROUP—12 Volt—Part 2  
 Serial No. 79U2274 to 79U2855 inclusive  
 6S4381 Harness parts are shown on Page 23

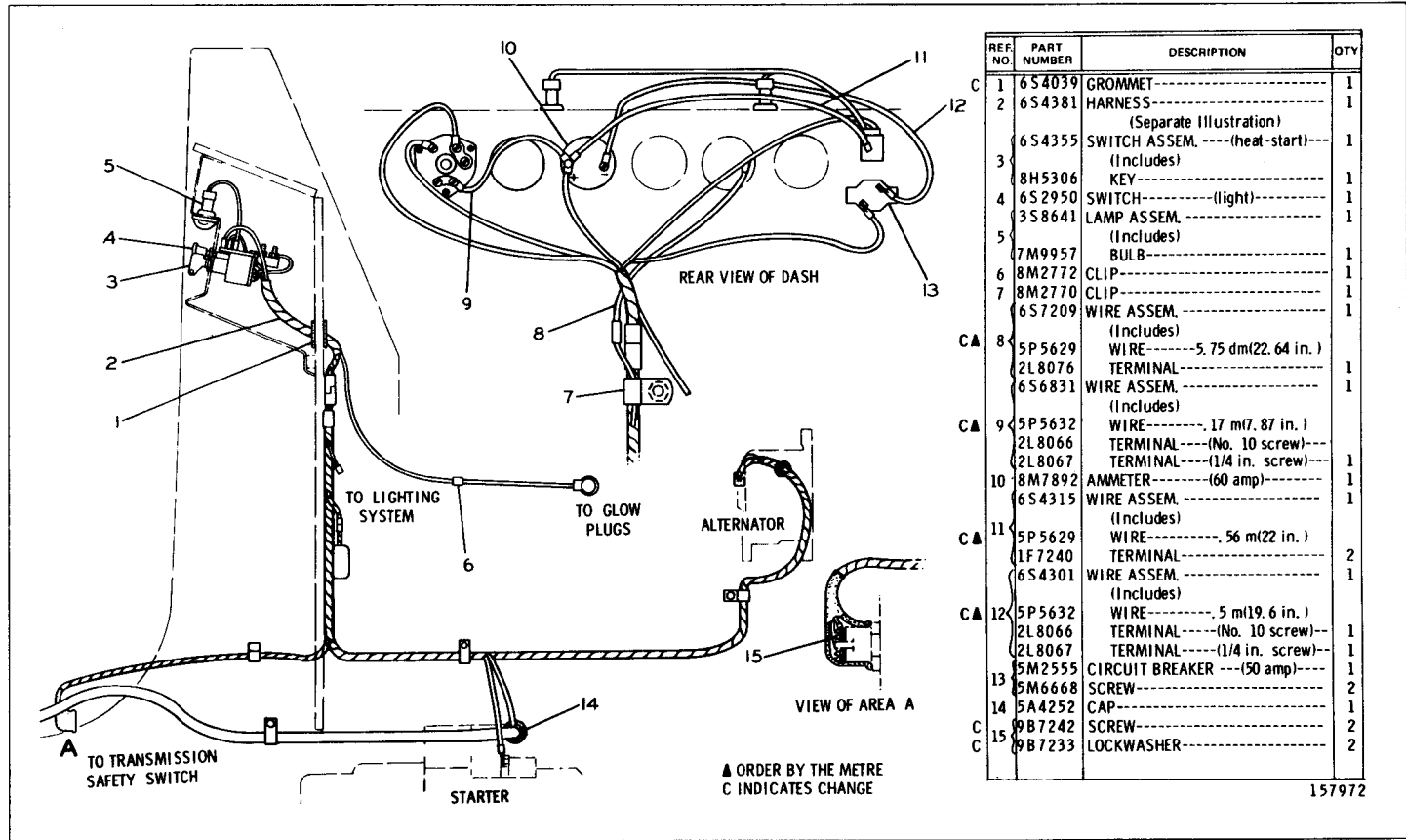

REF. NO.	PART NUMBER	DESCRIPTION	QTY
C 1	6S4039	GROMMET-----	1
2	6S4381	HARNES-----	1
		(Separate Illustration)	
	6S4355	SWITCH ASSEM.----(heat-start)---	1
3	8H5306	KEY-----	1
4	6S2950	SWITCH----- (light)-----	1
	3S8641	LAMP ASSEM.-----	1
5		(Includes)	
	7M9957	BULB-----	1
6	8M2772	CLIP-----	1
7	8M2770	CLIP-----	1
	6S7209	WIRE ASSEM.-----	1
		(Includes)	
CA 8	5P5629	WIRE-----5.75 dm(22.64 in.)	
	2L8076	TERMINAL-----	1
	6S6831	WIRE ASSEM.-----	1
		(Includes)	
CA 9	5P5632	WIRE-----17 m(7.87 in.)	
	2L8066	TERMINAL-----(No. 10 screw)---	1
	2L8067	TERMINAL-----(1/4 in. screw)---	1
10	8M7892	AMMETER-----(60 amp)---	1
	6S4315	WIRE ASSEM.-----	1
		(Includes)	
CA 11	5P5629	WIRE-----56 m(22 in.)	
	1F7240	TERMINAL-----	2
	6S4301	WIRE ASSEM.-----	1
		(Includes)	
CA 12	5P5632	WIRE-----5 m(19.6 in.)	
	2L8066	TERMINAL-----(No. 10 screw)---	1
	2L8067	TERMINAL-----(1/4 in. screw)---	1
	5M2555	CIRCUIT BREAKER --- (50 amp)---	1
13	5M6668	SCREW-----	2
14	5A4252	CAP-----	1
C 15	9B7242	SCREW-----	2
C	9B7233	LOCKWASHER-----	2

STARTING AND ELECTRICAL SYSTEM

REF. NO.	PART NUMBER	DESCRIPTION	QTY
1	4M1111	MAT-----	1
	6K4355	ROD-----	4
	1B4330	NUT-----	4
2	3B4607	COTTER PIN-----	4
	3B4504	LOCKWASHER-----	4
	4B4276	WASHER-----	4
3	4K6697	HOLD DOWN ASSEM.-----	1
4	3H2900	GROMMET-----	1
5	5H3631	CABLE ASSEM.-----	1
	1S7252	TERMINAL (ground)-----	1
	5M9205	TERMINAL ASSEM.-----	1
6	1M6119	BOLT-----	1
	1M6120	NUT-----	1
7	3B1915	BOLT-----	1
	2B941	BOSS-----	1

4N5110	REGULATOR ASSEM.-----	1	
8	S1614	BOLT-----	2
	3B4607	LOCKWASHER-----	2
9	6S4382	HARNES ASSEM.-----	1

(Separate Illustration)

6S4302	CABLE ASSEM.-----	1	
10	5P746	CABLE-----29 cm(11.25 in.)	1
	1S7252	TERMINAL-----	2
11	4S9261	BATTERY-----	1
12	4B4278	WASHER-----	2
13	5K3294	CLIP-----	1
	3F1685	CABLE ASSEM.-----	1
▲ 14	5P746	CABLE-----221 cm(87 in.)	1
	1S7252	TERMINAL-----	1
15	5M9204	TERMINAL ASSEM.-----	1
16	1M6119	BOLT-----	1
	1M6120	NUT-----	1
17	T102	BOLT-----	1
18	3B4506	LOCKWASHER-----	2
	2H3755	BOLT-----	1
19	3B4505	LOCKWASHER-----	1
20	3S2093	STRAP-----	1
21	8M2770	CLIP-----	4

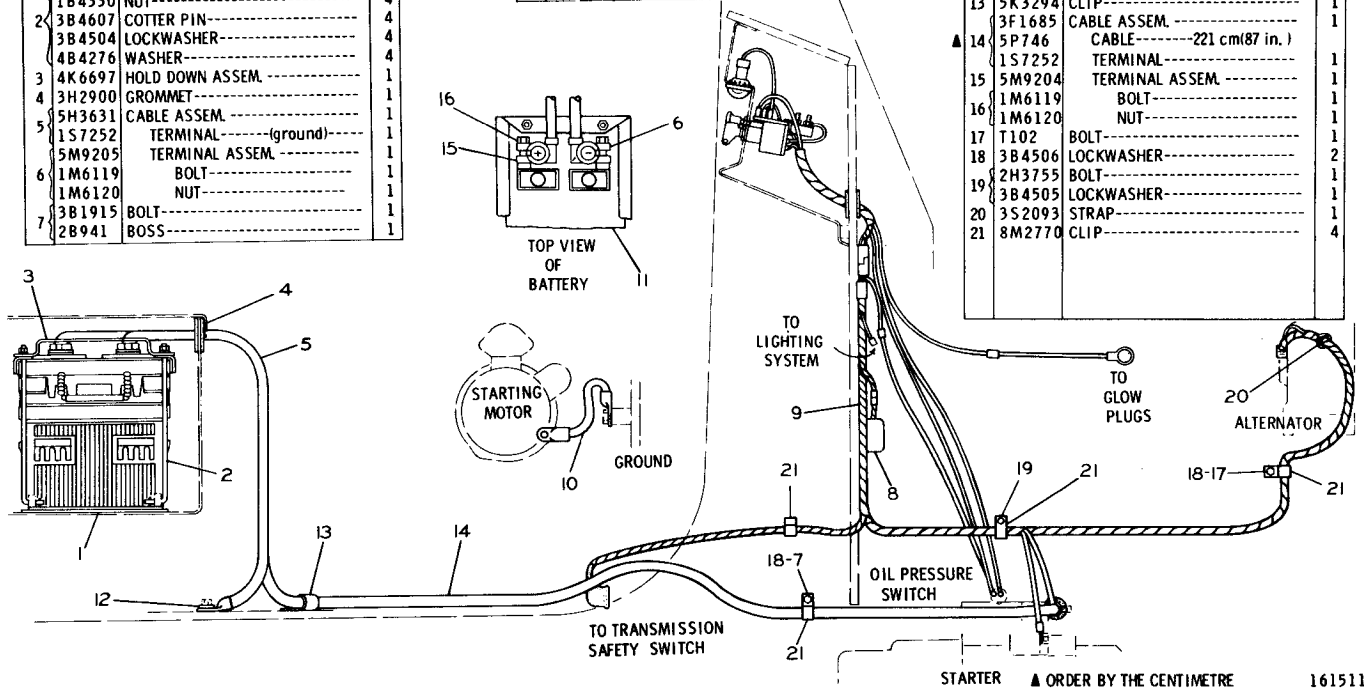

6S3514 BATTERY AND WIRING GROUP—12 Volt—Part 1  
 Serial No. 79U2856—Up  
 6S4382 Harness parts are shown on Page 23

STARTER ▲ ORDER BY THE CENTIMETRE 161511

**6S3514 BATTERY AND WIRING GROUP—12 Volt—Part 2**  
 Serial No. 79U2856—Up  
 6S4381 Harness parts are shown on Page 23

REF NO.	PART NUMBER	DESCRIPTION	QTY
1	6S4039	GROMMET	1
2	6S4381	HARNESS (Separate Illustration)	1

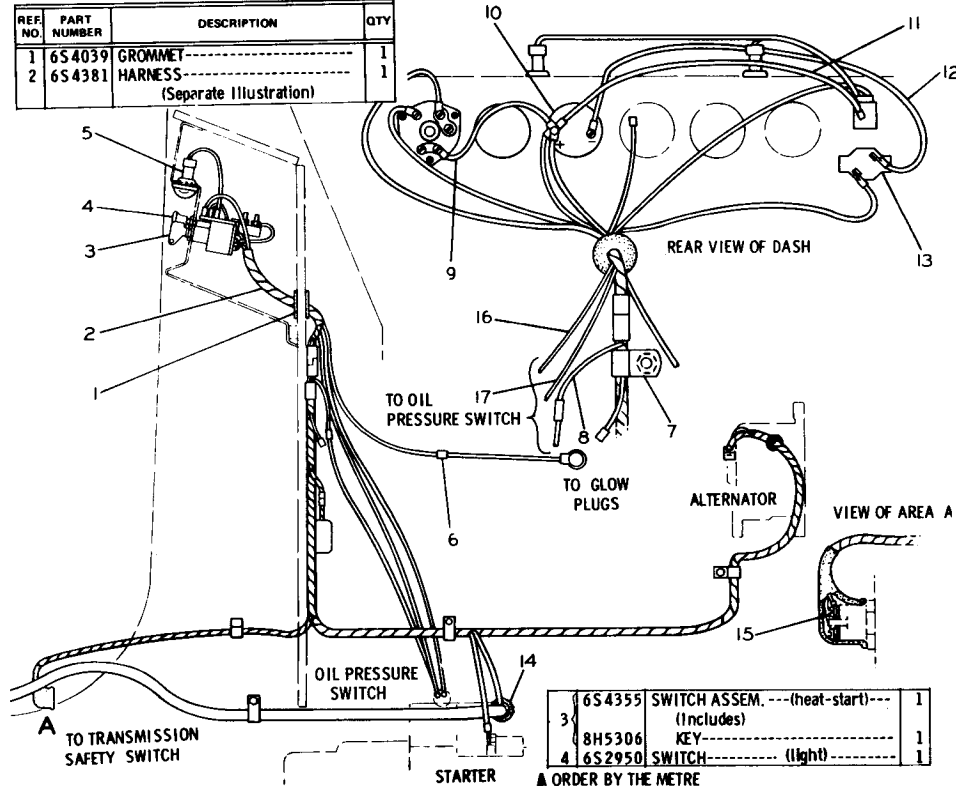

3	6S4355	SWITCH ASSEM. --- (heat-start) ---	1
		(Includes)	
	8H5306	KEY	1
4	6S2950	SWITCH	1

▲ ORDER BY THE METRE

	3S8641	LAMP ASSEM. -----	1	
		(Includes)		
C	5	6N8742	BODY ASSEM. -----	1
		7M9957	BULB-----	1
	6	8M2772	CLIP-----	1
	7	8M2770	CLIP-----	1
		6S7209	WIRE ASSEM. -----	1
		(Includes)		
▲	8	5P5629	WIRE----- .575 m (22.64 in.)	
C		2L8075	TERMINAL-----	1
		6S6831	WIRE ASSEM. -----	1
		(Includes)		
▲	9	5P5632	WIRE----- .17 m (7.87 in.)	
		2L8066	TERMINAL--- (No. 10 screw)---	
		2L8067	TERMINAL--- (1/4 in. screw)---	1
	10	8M7892	AMMETER--- (60 amp)---	1
		6S4315	WIRE ASSEM. -----	1
		(Includes)		
▲	11	5P5629	WIRE----- .56 m (22 in.)	
		1F7240	TERMINAL-----	2
		6S4301	WIRE ASSEM. -----	1
		(Includes)		
▲	12	5P5632	WIRE----- .5 m (19.6 in.)	
		2L8066	TERMINAL--- (No. 10 screw)---	1
		2L8067	TERMINAL--- (1/4 in. screw)---	1
	13	5M2555	CIRCUIT BREAKER--- (50 amp)---	1
		5M6668	SCREW-----	2
	14	5A4252	CAP-----	1
		9B7242	SCREW-----	2
		9B7233	LOCKWASHER-----	2
C		6S8881	WIRE ASSEM. -----	1
		(Includes)		
▲	16	5P5629	WIRE----- 1.15 m (45.28 in.)	
		2L8075	TERMINAL--- (No. 8 screw)---	1
		2L8076	TERMINAL--- (No. 10 screw)---	1
C		6S8880	WIRE ASSEM. -----	1
		(Includes)		
▲	17	5P5629	WIRE----- 1.15 m (45.28 in.)	
		2L8075	TERMINAL-----	2

C INDICATES CHANGE

161512

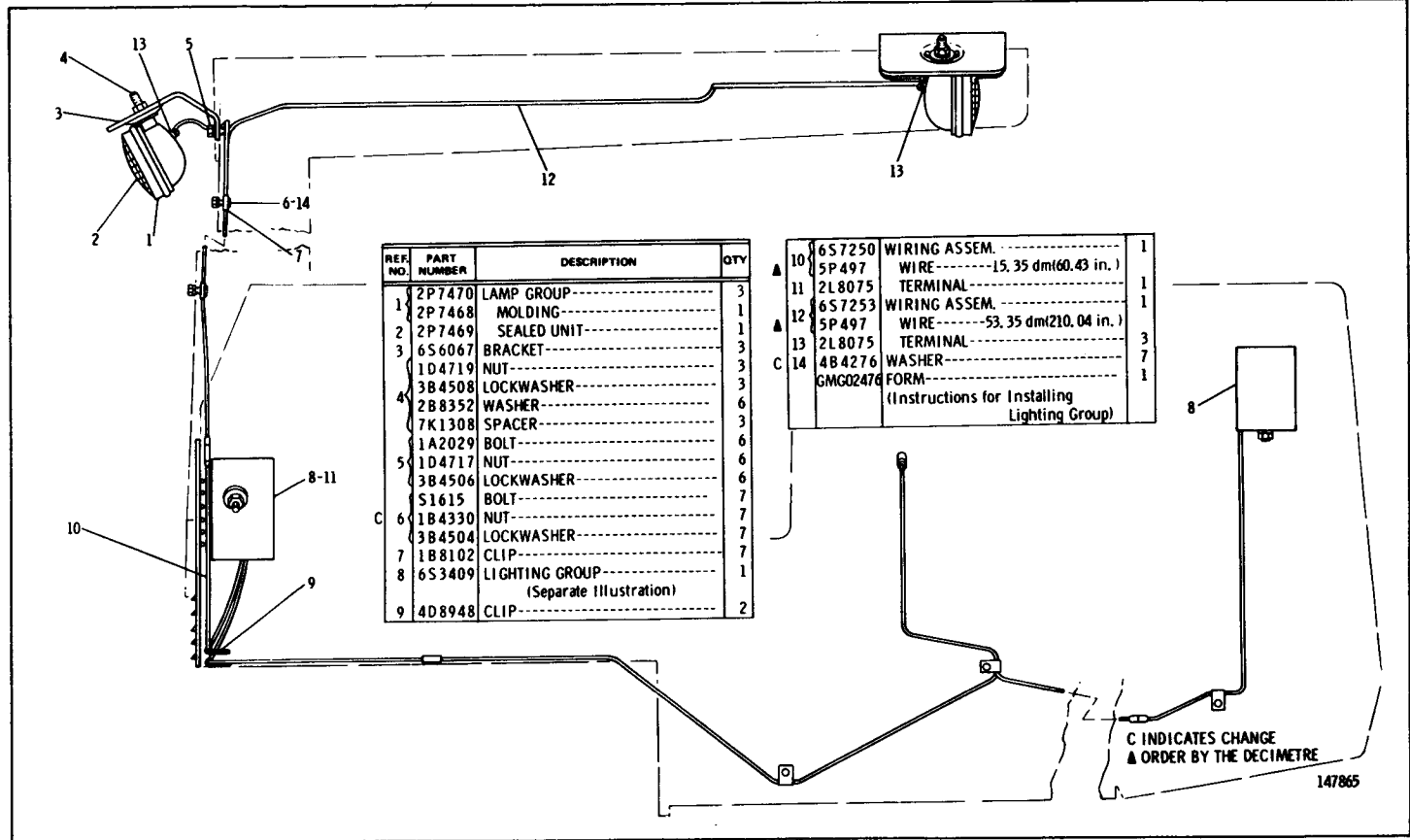

6S4840 LIGHTING GROUP—12 Volt—6 Lamp  
FOR USE WITH ROLL-OVER PROTECTIVE STRUCTURE  
AN ATTACHMENT

**6S3409 LIGHTING GROUP—12 Volt—3 Lamp**  
**Also part of 6S4840 Lighting Group**  
**AN ATTACHMENT**

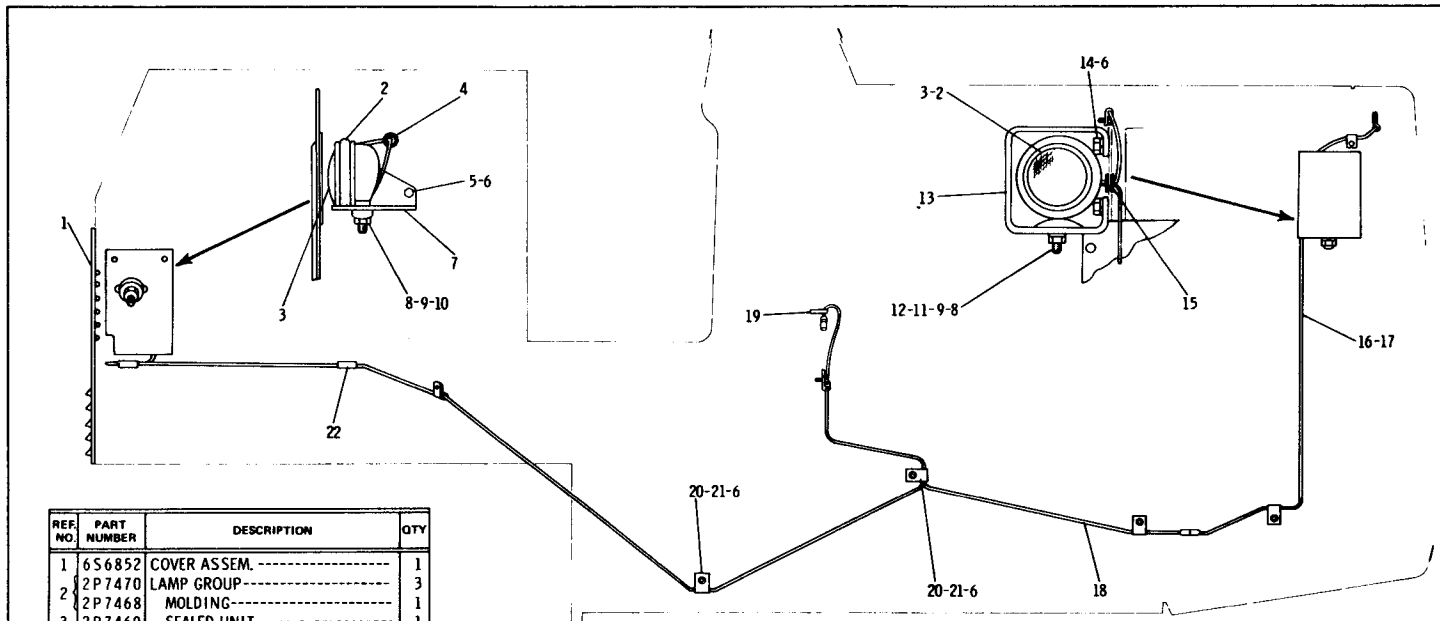

REF NO.	PART NUMBER	DESCRIPTION	QTY
1	6S6852	COVER ASSEM.-----	1
2	2P7470	LAMP GROUP-----	3
3	2P7468	MOLDING-----	1
4	2P7469	SEALED UNIT-----	1
5	617831	GROMMET-----	1
6	L1351	BOLT-----	3
7	3B4506	LOCKWASHER-----	18
8	6S6858	BRACKET-----	1
9	1D4719	NUT-----	3
10	3B4508	LOCKWASHER-----	3
11	6S6857	WASHER-----	2
12	7S9885	WASHER-----	2
13	2B8352	WASHER-----	4
	6S6752	GUARD-----	2

14	51594	BOLT-----	8
	4B4278	WASHER-----	8
15	8L3948	GROMMET-----	2
	6S4414	WIRE ASSEM.-----	1
C ▲ 16	5P497	WIRE-----21.90 dm(86.22 in.)	1
C 17	2L8075	TERMINAL-----	2
	6S4421	HARNES ASSEM.-----	1
C ▲ 18	5P497	WIRE----- (14 gauge)	1
C	2L8075	TERMINAL-----	1

C 19	3S2093	STRAP-----	1
C 20	8M2772	CLIP-----	10
C 21	T102	BOLT-----	7
22	4D8948	CLIP-----	3

▲ ORDER BY THE FOOT

C INDICATES CHANGE

149304



REF. NO.	PART NUMBER	DESCRIPTION	QTY
1	3P8992	SPEAKER ASSEM.-----	1
2	T284	BOLT-----	3
	3B4504	LOCKWASHER-----	3
3	6S8388	SUPPORT ASSEM.-----	1
4	S1588	BOLT-----	2
5	6S8390	HARNES ASSEM.----- (Separate Illustration)	1
6	3P3339	SCREW-----	4
	4B2049	NUT-----	8
	8F1434	WASHER-----	4

▲	657768	WIRE ASSEM.-----	1
		(Includes)	
7	5P497	WIRE-----5,6 dm(22.05 in.)	1
▲	5P384	TUBE-----5 dm(19.69 in.)	1
8	2S5012	CAP-----	1
	2S5014	CONTACT-----	1
9	2L8078	TERMINAL-----	1
10	3P8989	FUSE-----2 amp-----	1
11	2N3477	SCREW-----	4
	3P3335	GROMMET-----	4
12	3P3337	COVER-----	1
	3P3336	SEAL-----	1
13	2P5007	CIRCUIT ASSEM.-----	1
14	3S2093	STRAP-----	18
15	6S6861	SWITCH----- (momentary)-----	1
	4B3388	BOLT-----	2
16	7S6369	WASHER----- (.188 in. thick)-----	2
	4B4277	WASHER----- (.0625 in. thick)-----	2
17	6S6688	BRACKET-----	1
	6S8396	WIRE ASSEM.-----	1
		(Includes)	
▲	5P497	WIRE-----13.50 dm(53.15 in.)	1
▲	5P687	TUBE-----13.50 dm(53.15 in.)	1
19	2L8075	TERMINAL-----	1
	GMG02431	FORM-----	1
		(Installing Back-up Warning Alarm)	

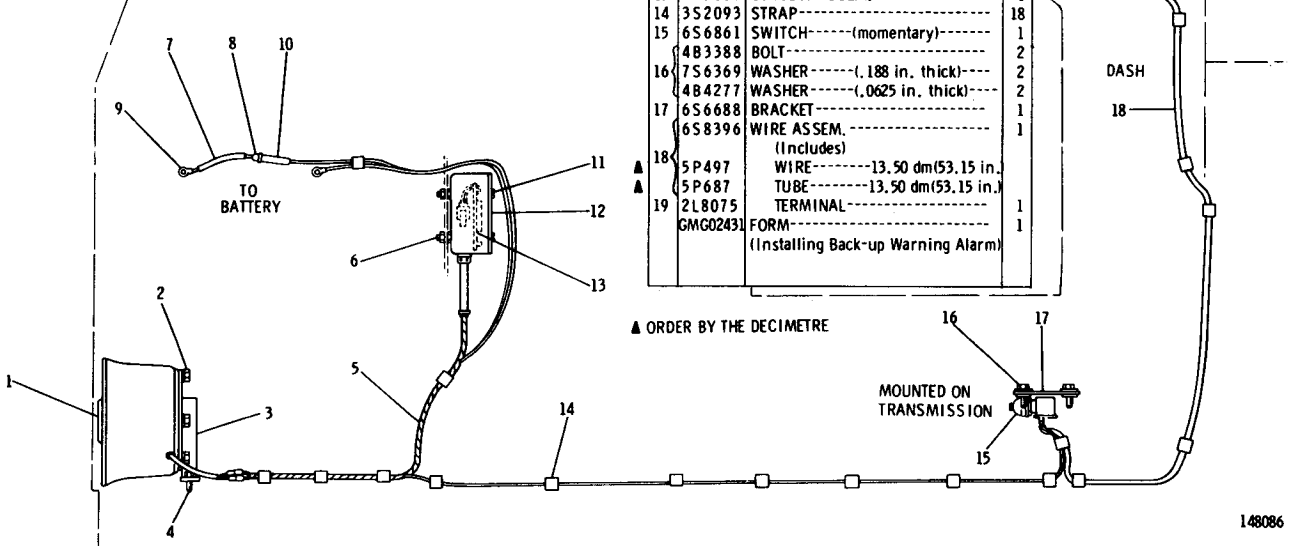

▲ ORDER BY THE DECIMETRE

148086

6S8154 BACKUP WARNING GROUP  
AN ATTACHMENT

6S8154 BACK-UP WARNING GROUP—Type 2  
 Replaced by 6S8715 Back-Up Warning Group shown on Page 27A-2  
 6S8390 Harness parts are shown on Page 27B  
 AN ATTACHMENT

REF. NO.	PART NUMBER	DESCRIPTION	QTY
1	3P8992	SPEAKER ASSEM.-----	1
	T284	BOLT-----	3
2	3B4504	LOCKWASHER-----	3
3	6S8388	SUPPORT ASSEM.-----	1
4	S1588	BOLT-----	2
5	6S8390	HARNESS ASSEM.----- (Separate Illustration)	1
	3P3339	SCREW-----	4
6	4B2049	NUT-----	8
	8F1434	WASHER-----	4

	6S7768	WIRE ASSEM.-----	1
		(Includes)	
7	5P5629	WIRE-----, 56 m(22.05 in.)	1
	5P5996	TUBE-----, 5 m(19.69 in.)	1
8	2S5012	CAP-----	1
	2S5014	CONTACT-----	1
9	2L8078	TERMINAL-----	1
10	3P8989	FUSE----- (2 amp)	1
	2N3477	SCREW-----	4
11	3P3335	GROMMET-----	4
	3P3337	COVER-----	1
12	3P3336	SEAL-----	1
13	2P5007	CIRCUIT ASSEM.-----	1
14	3S2093	STRAP-----	18
15	6S6861	SWITCH----- (momentary)	1
	4B3388	BOLT-----	2
16	7S6369	WASHER---4.78 mm(L. 88 in.) thick	2
	4B4277	WASHER---1.58 mm(.0625 in.) thick	2
17	6S6688	BRACKET-----	1
	6S8396	WIRE ASSEM.-----	1
		(Includes)	
18	5P5629	WIRE-----1.35 m(53.15 in.)	1
	5P5999	TUBE-----1.35 m(53.15 in.)	1
19	2L8075	TERMINAL-----	1
	6S8730	BRACKET-----	1
	6S8732	LEVER-----	1
20	2H3755	BOLT-----	1
	3B4505	LOCKWASHER-----	1

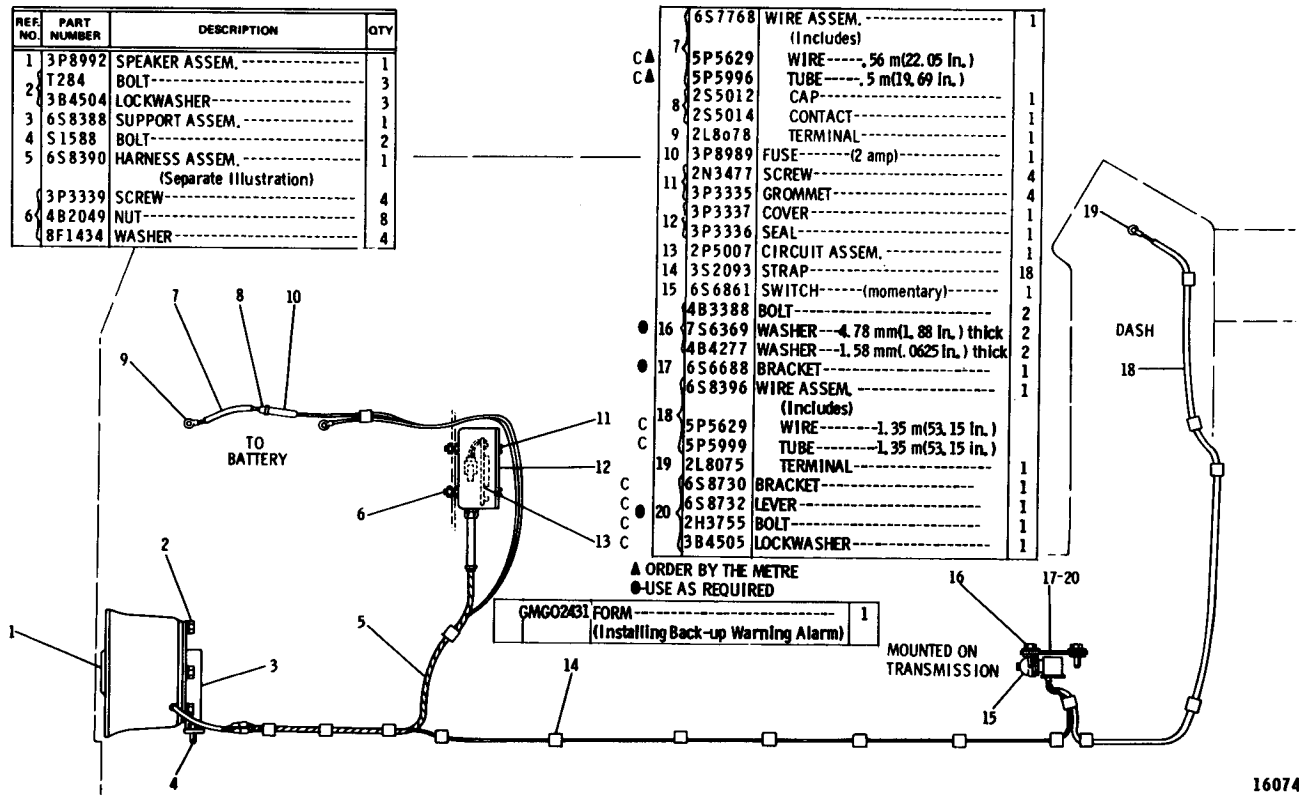

▲ ORDER BY THE METRE  
 ● USE AS REQUIRED

GMGO2431 FORM----- 1  
 (Installing Back-up Warning Alarm)

MOUNTED ON TRANSMISSION

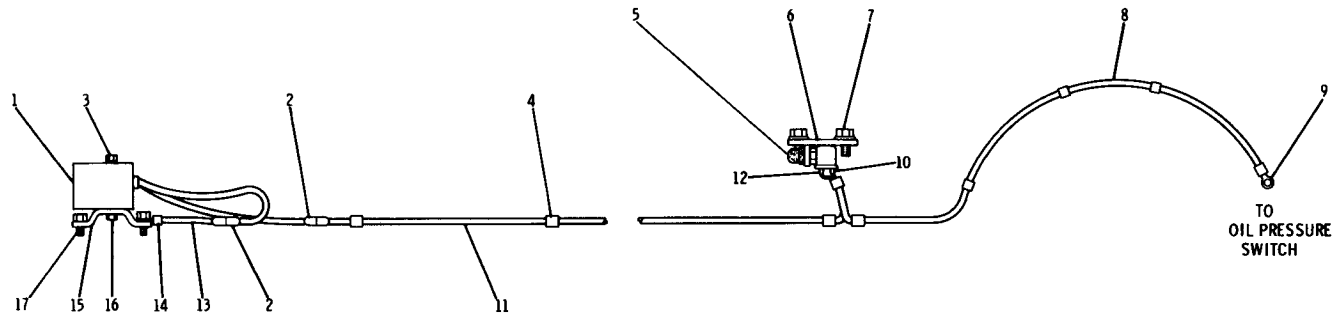

REF. NO.	PART NUMBER	DESCRIPTION	QTY
1	6P8576	BACK-UP ALARM----- (Includes)	1
2	5P6725	CONNECTOR ASSEM.-----	2
3	S1608	BOLT-----	2
3	3K8909	LOCKWASHER-----	2
4	3S2093	STRAP-----	9
5	6S6861	SWITCH----- (transmission)	1
6	6S6688	BRACKET-----	1
7	S1618	BOLT-----	2
7	4B4277	WASHER-----	2

▲	8	6S8396	WIRE ASSEM.----- (Includes)	1
▲	8	5P5999	TUBE-----1.35 m (53.15 in.)	
▲	9	5P5629	WIRE-----1.35 m (53.15 in.)	
	9	2L8075	TERMINAL-----	1
	10	6K613	TERMINAL-----	1
	11	6S8714	WIRE ASSEM.----- (Includes)	1
▲	11	5P5629	WIRE-----1.13 m (44.49 in.)	
	12	6K613	TERMINAL-----	1
	13	6S9169	WIRE ASSEM.----- (Includes)	1
▲	13	5P5629	WIRE-----.125 m (4.92 in.)	
▲	14	2L8079	TERMINAL-----	1

15	6S9229	PLATE ASSEM.----- (Each Includes)	2
16	9F2978	NUT-----	1
17	S1588	BOLT-----	4

▲ ORDER BY THE METRE

160744

6S8715 BACK-UP WARNING GROUP  
AN ATTACHMENT

6S8715 BACK-UP WARNING GROUP—Type 2  
AN ATTACHMENT

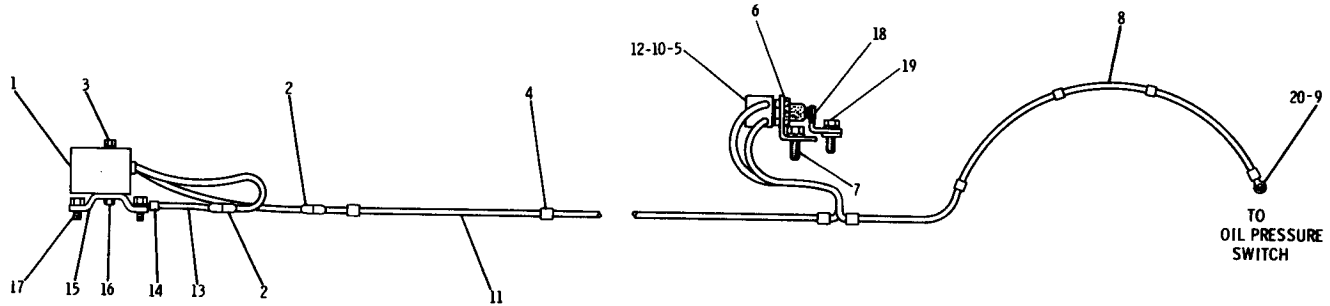

REF. NO.	PART NUMBER	DESCRIPTION	QTY
1	6P8576	BACK-UP ALARM----- (Includes)	1
2	5P6725	CONNECTOR ASSEM.-----	2
3	S1608	BOLT-----	2
	3K8909	LOCKWASHER-----	2
4	3S2093	STRAP-----	9
5	6S6861	SWITCH----- (transmission)	1
C 6	6S8730	BRACKET-----	1
7	S1618	BOLT-----	2
	4B4277	WASHER-----	2

	6S8396	WIRE ASSEM.-----	1
		(Includes)	
8	5P5999	TUBE-----1.35 m (53.15 in.)	1
▲	5P5629	WIRE-----1.35 m (53.15 in.)	1
9	2L8075	TERMINAL-----	1
10	6K613	TERMINAL-----	1
	6S8714	WIRE ASSEM.-----	1
		(Includes)	
▲	5P5629	WIRE-----1.13 m (44.49 in.)	1
12	6K613	TERMINAL-----	1
	6S9169	WIRE ASSEM.-----	1
		(Includes)	
▲	5P5629	WIRE-----1.25 m (4.92 in.)	1
14	2L8079	TERMINAL-----	1

C INDICATES CHANGE

15	6S9229	PLATE ASSEM.-----	2
		(Each Includes)	
16	9F2978	NUT-----	1
17	S1588	BOLT-----	4
C 18	6S8732	LEVER-----	1
C 19	2H3755	BOLT-----	1
C	3B4505	LOCKWASHER-----	1
C 20	4B1220	SCREW-----	1

▲ ORDER BY THE METRE

164716

6S8390 WIRING HARNESS ASSEMBLY  
Part of 6S8154 Backup Warning Group

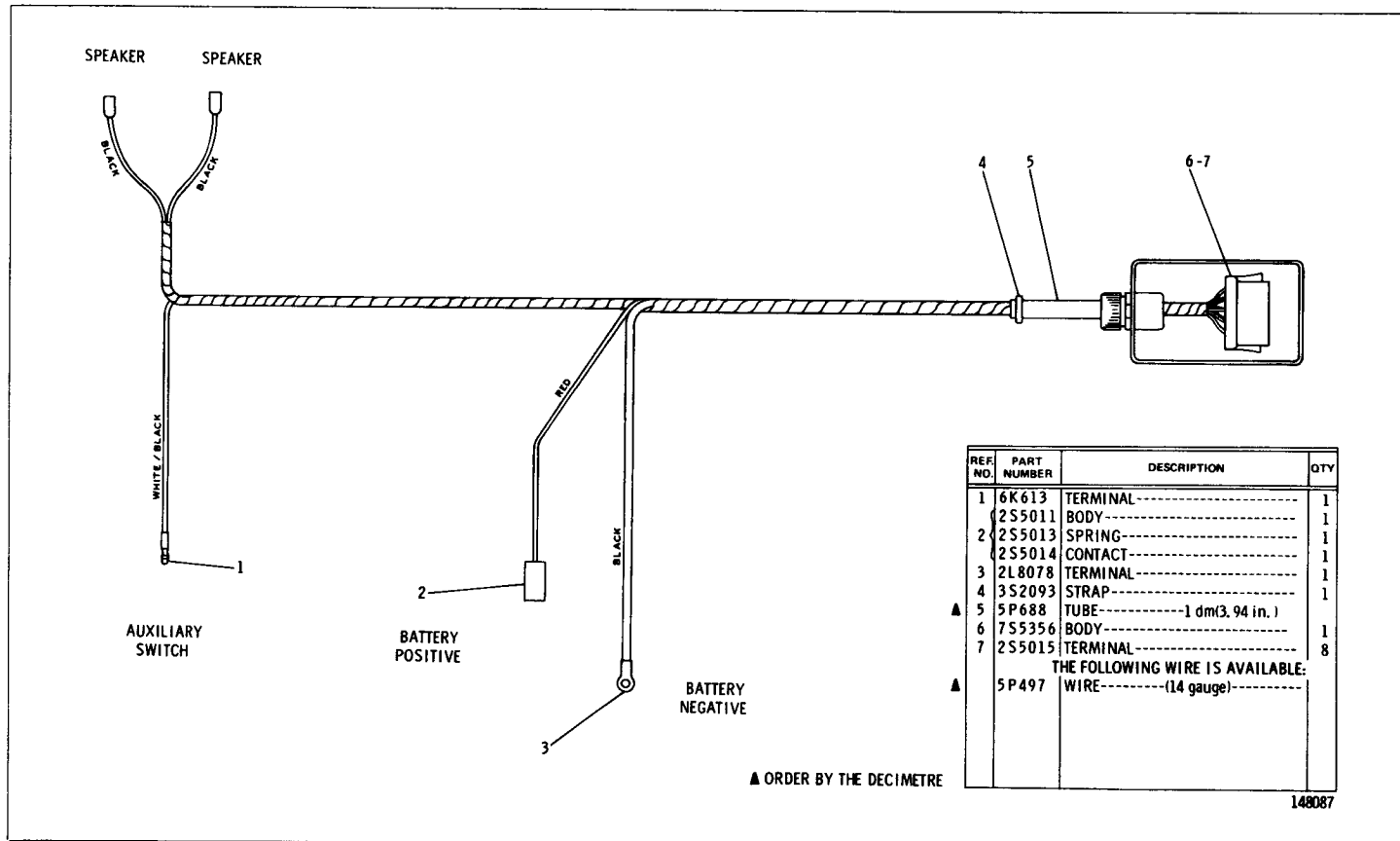

REF NO.	PART NUMBER	DESCRIPTION	QTY
1	6K613	TERMINAL-----	1
	2S5011	BODY-----	1
2	2S5013	SPRING-----	1
	2S5014	CONTACT-----	1
3	2L8078	TERMINAL-----	1
4	3S2093	STRAP-----	1
▲	5P688	TUBE-----1 dm(3.94 in.)	1
6	7S5356	BODY-----	1
7	2S5015	TERMINAL-----	8
		THE FOLLOWING WIRE IS AVAILABLE:	
▲	5P497	WIRE----- (14 gauge)-----	

▲ ORDER BY THE DECIMETRE

148087

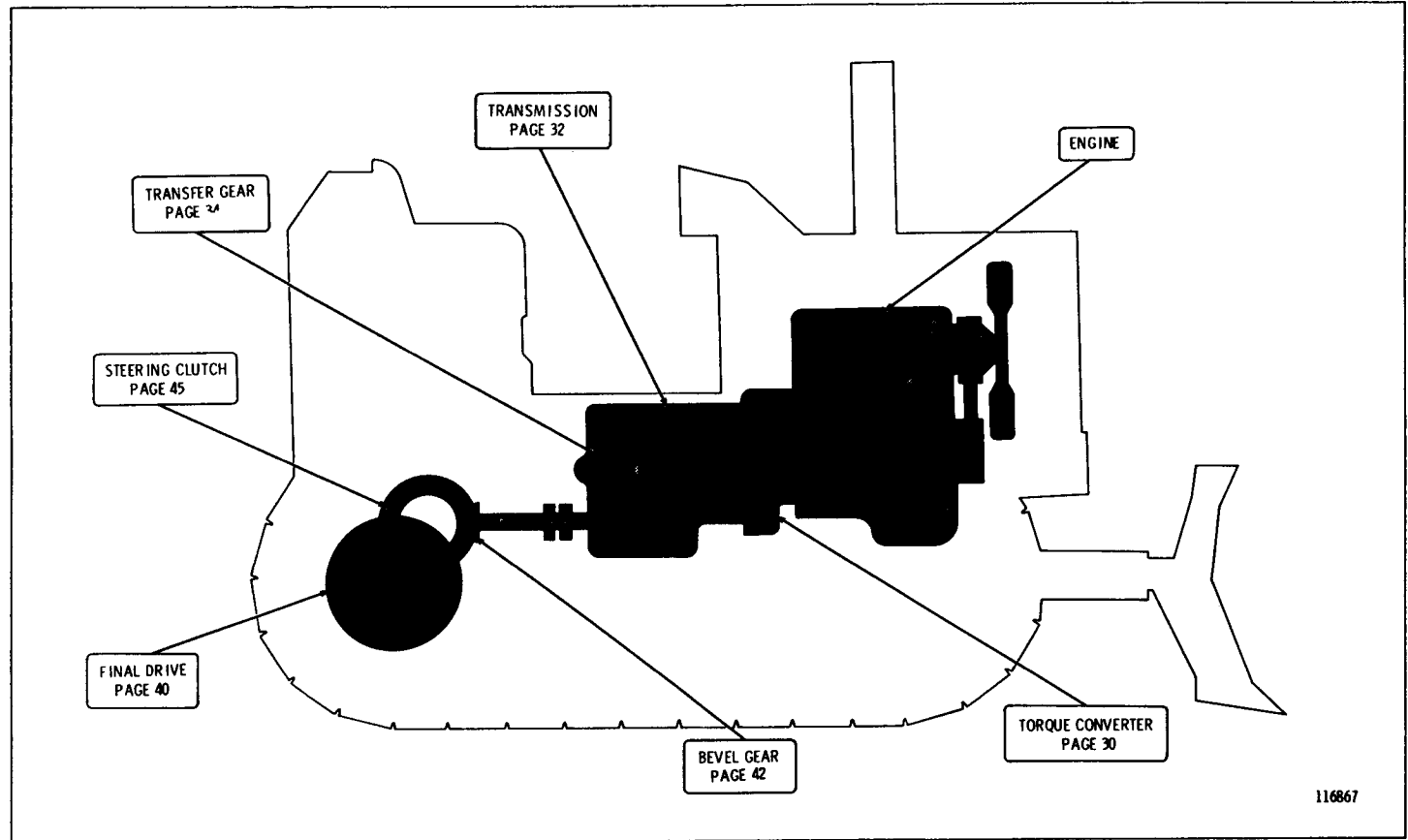

116867

POWER TRAIN ARRANGEMENT

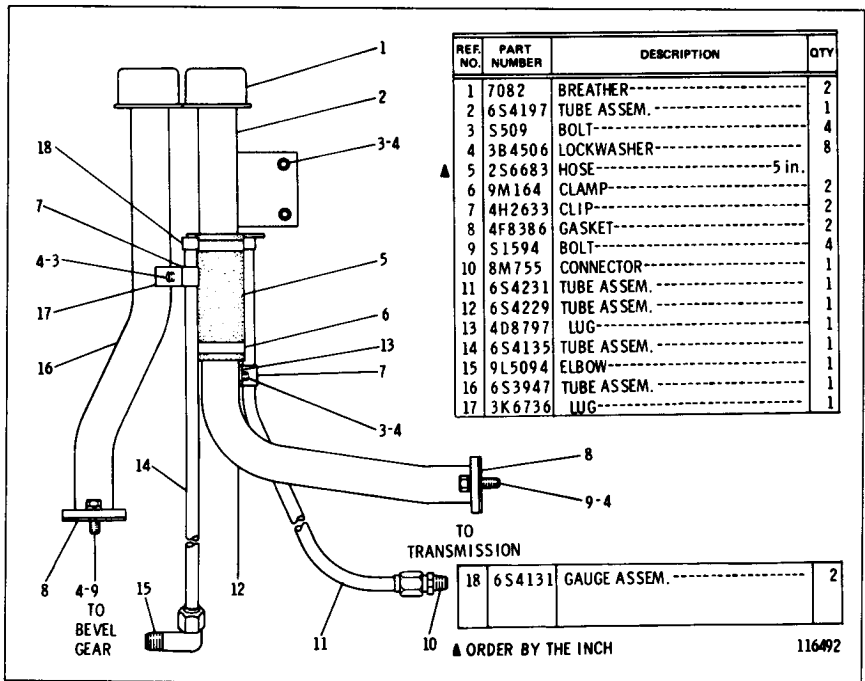

6S3533 TRANSMISSION OIL FILLER GROUP  
Serial No. 79U1 to 79U2989 inclusive

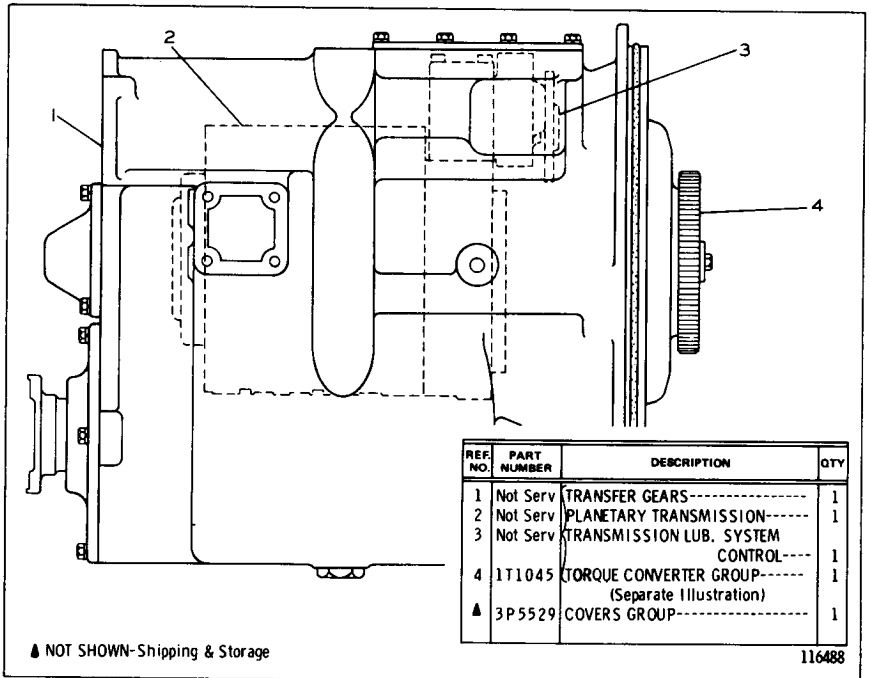

2P3701 TRANSMISSION ARRANGEMENT  
1T1045 Torque Converter, Planetary Transmission, Transfer Gears and Transmission Lubrication System Control parts are shown on Pages 29B and 32 through 36

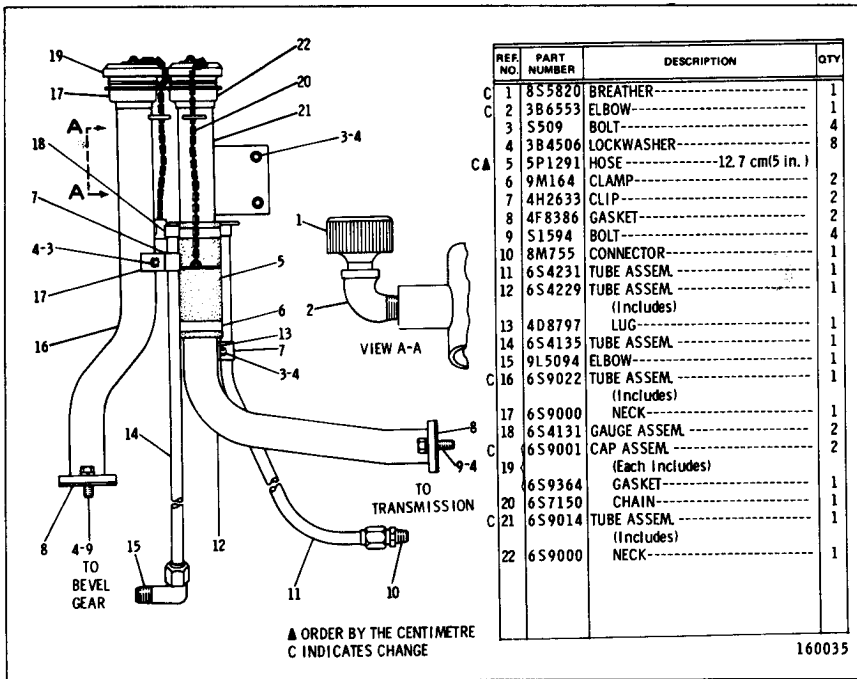

**6S3533 TRANSMISSION OIL FILLER GROUP**  
Serial No. 79U2990—Up



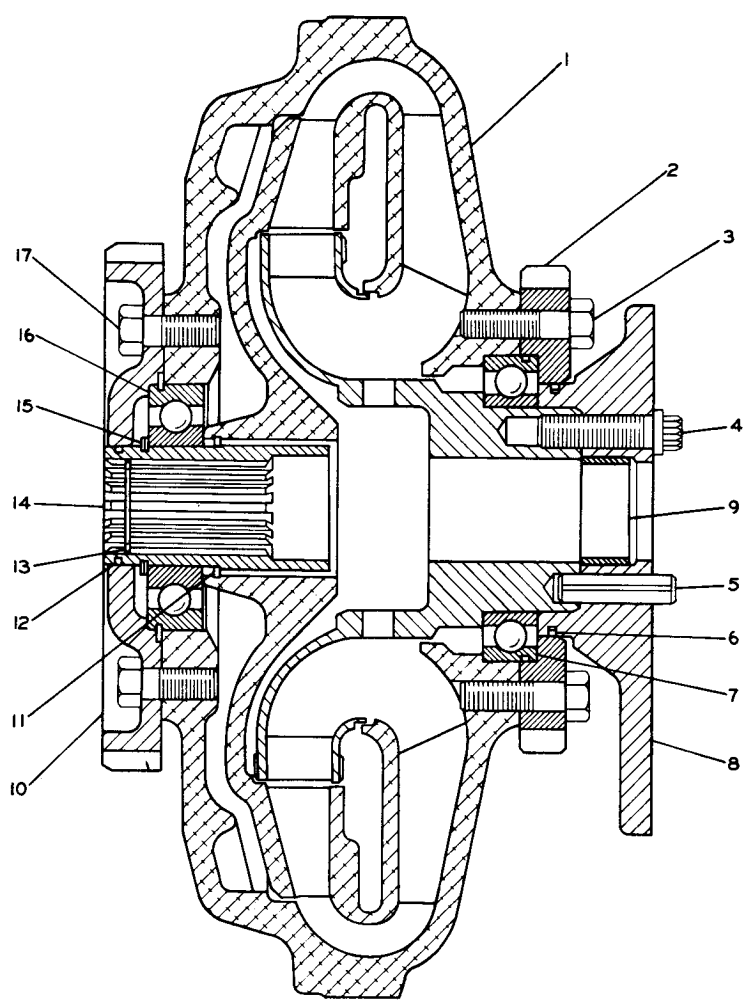

REF. NO.	PART NUMBER	DESCRIPTION	QTY
1	1T1021	HOUSING ASSEM.	1
2	1T1002	GEAR-----(48 Teeth)	1
3	3B1915	BOLT-----	8
4	5P76	BOLT-----	4
5	2J5850	PIN-----	2
C 6	1T1231	RING-----	1
7	1T994	BEARING-----	1
8	1T1054	FLANGE ASSEM.	1
9	2M2827	BEARING-----	1
10	1T1003	SPIDER-----	1

11	1T1004	RING-----	1
12	1T1230	RING-----	1
13	3K6837	RING-----	1
14	1T996	HUB-----	1
15	1J6470	RING-----	1
16	1T993	BEARING-----	1
17	51594	BOLT-----	12

C INDICATES CHANGE

156651

1T1045 TORQUE CONVERTER GROUP  
Part of 2P3701 Transmission Arrangement shown on Page 29

REF. NO.	PART NUMBER	DESCRIPTION	QTY
C 1	S509	BOLT-----	5
C 2	3B4506	LOCKWASHER-----	5
3	6S4087	GUARD ASSEM.-----	1
4	7M706	KNOB-----	1
5	6S3849	LEVER-----	1
6	6S3790	PLATE-----	1
7	5M7516	SCREW-----	4
C 8	6S8892	LOCK ASSEM.-----	1
9	6S4451	SHAFT-----	1
10	3B4617	COTTER PIN-----	2
11	6K3427	PIN-----	1
12	3B4621	COTTER PIN-----	1
13	6S3865	LEVER ASSEM.-----	1
14	9H2400	BEARING-----	3
15	6S3903	BRACKET ASSEM.-----	1
16	4K4658	STUD-----	1
17	1B1067	WASHER-----	1

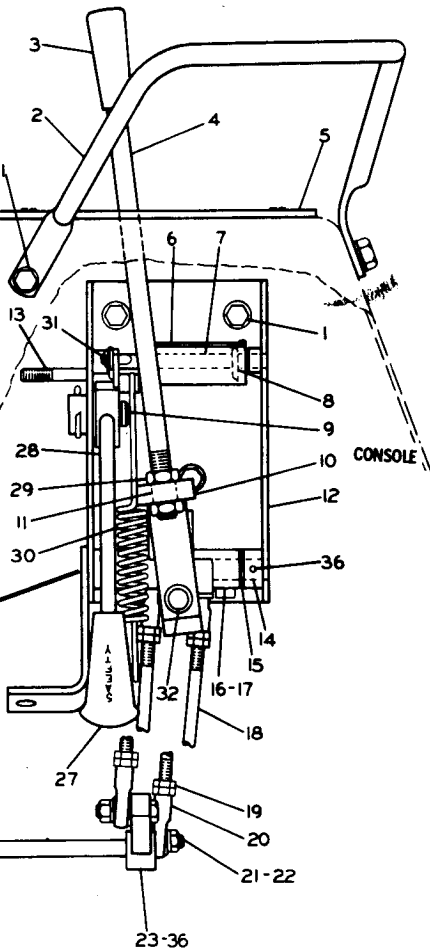

14	6S3819	SHAFT-----	1
15	T883	WASHER----- (use as required)---	4
16	6S3884	LEVER ASSEM.-----	1
17	9H2400	BEARING-----	2
18	5L4872	ROD-----	2
19	1A8285	NUT-----	6
20	7H3641	ROD END-----	6
21	1B2790	BOLT-----	4
22	1D4716	NUT-----	6
23	3B4505	LOCKWASHER-----	6
24	6S6916	LEVER ASSEM.-----	1
25	6S3879	ROD-----	1
26	1B7182	BOLT-----	2

26	6S3892	SHAFT ASSEM.-----	1
27	2M8908	KNOB-----	1
28	6S6912	LEVER ASSEM.-----	1
29	1D5117	NUT-----	2
30	4D4971	SPRING-----	1
31	6S6915	ROD-----	1
32	3B4607	COTTER PIN-----	2
33	4B4276	WASHER-----	4
34	6S3848	SHAFT-----	1
35	6S3846	BAR ASSEM.-----	1
36	4H2610	BUSHING-----	1
37	6S3881	LEVER ASSEM.-----	1
38	9H2400	BEARING-----	2
39	6H3956	PIN-----	3

C INDICATES CHANGE

160752

6S3535 TRANSMISSION CONTROL GROUP  
Serial No. 79U1 to 79U2665 inclusive

REF. NO.	PART NUMBER	DESCRIPTION	QTY
1	5509	BOLT-----	5
	3B4506	LOCKWASHER-----	5
2	6S4087	GUARD ASSEM.-----	1
3	7M706	KNOB-----	1
4	6S3849	LEVER-----	1
5	6S3790	PLATE-----	1
C 6	4B1280	SCREW-----	4
	6S8892	LOCK ASSEM.-----	1
7	6S4451	SHAFT-----	1
8	3B4617	COTTER PIN-----	2
	6K3427	PIN-----	1
9	3B4621	COTTER PIN-----	1
C 10	6S9013	LEVER ASSEM.-----	1
		(Includes)	
11	9H2400	BEARING-----	3
12	6S3903	BRACKET ASSEM.-----	1
		(Includes)	
C 13	4K4658	STUD-----	1
	6S9199	WASHER-----	1

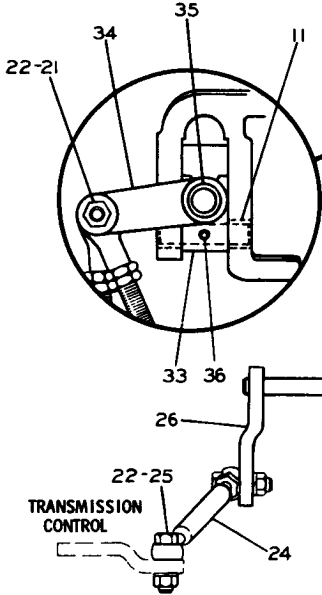
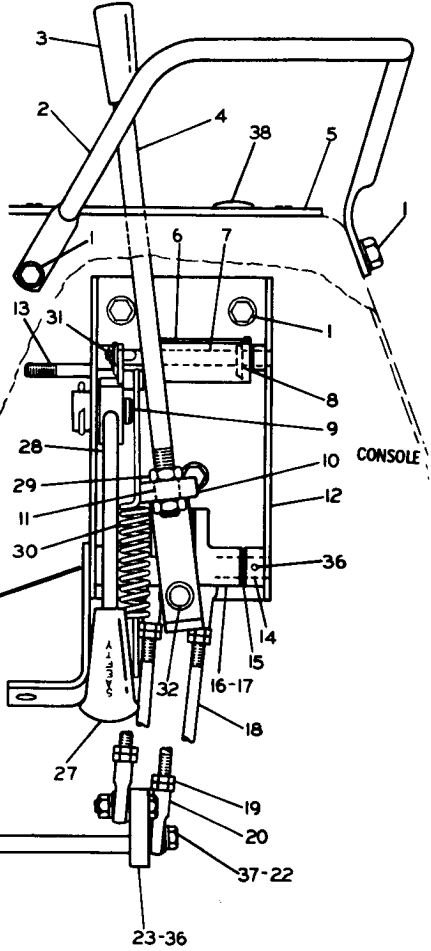

14	6S3819	SHAFT-----	1
15	T883	WASHER----- (use as required)--	4
C 16	6S9025	LEVER ASSEM.-----	1
		(Includes)	
17	9H2400	BEARING-----	2
18	5L4872	ROD-----	2
19	1A8285	NUT-----	6
20	7H3641	ROD END-----	6
C 21	1B2790	BOLT-----	2
	1D4716	NUT-----	6
22	3B4505	LOCKWASHER-----	6
C 23	6S9016	LEVER-----	1
	6S3879	ROD-----	1
C 24	6S3879	ROD-----	1
	1B7182	BOLT-----	2

26	6S3892	SHAFT ASSEM.-----	1
27	2M8908	KNOB-----	1
28	6S6912	LEVER ASSEM.-----	1
29	1D5117	NUT-----	2
30	4D4971	SPRING-----	1
	6S6915	ROD-----	1
31	3B4607	COTTER PIN-----	2
	4B4276	WASHER-----	4
32	6S3848	SHAFT-----	1
C 33	6S9031	BLOCK ASSEM.-----	1
		(Includes)	
	4H2610	BEARING-----	1
C 34	6S9021	LEVER ASSEM.-----	1
		(Includes)	
	9H2400	BEARING-----	2
	6H3956	PIN-----	3
C 37	1H5514	BOLT-----	2
C 38	5K3546	PLUG-----	1

C INDICATES CHANGE

217161

6S3535 TRANSMISSION CONTROL GROUP  
Serial No. 79U2666—Up

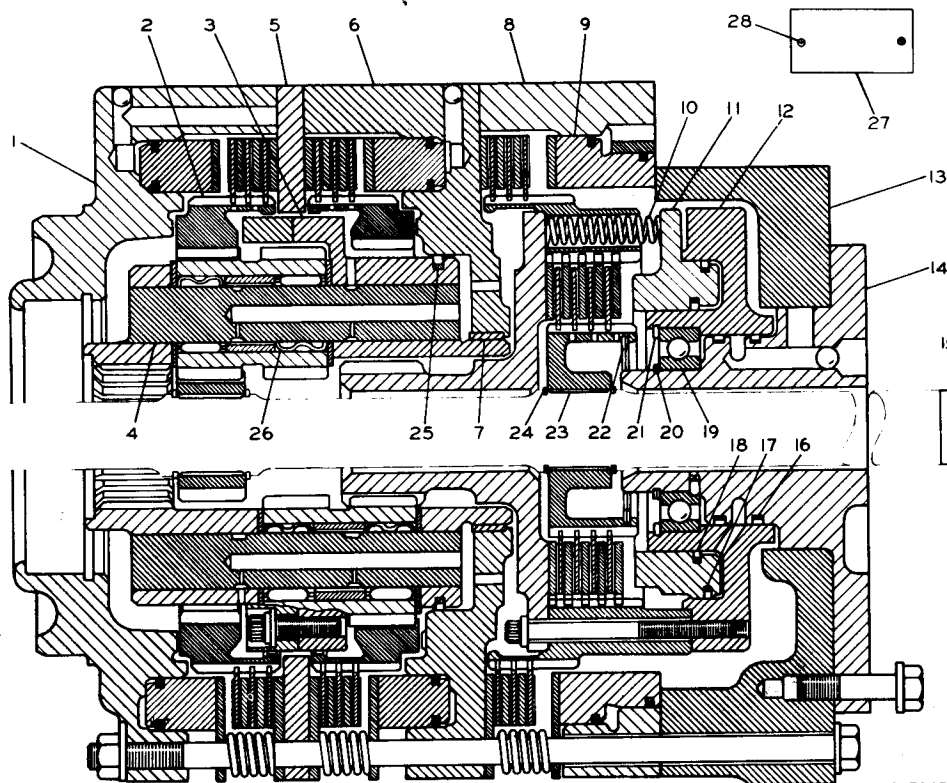

REF. NO.	PART NUMBER	DESCRIPTION	QTY
1	3P743	HOUSING ASSEM.	1
1	4B9880	BALL	1
2	9S6897	GEAR----- (54 Teeth)	1
3	9S8417	CARRIER ASSEM.	1
4	9S2774	SHAFT	3
5	9S6931	PLATE ASSEM.	1
5	9F2049	DOWEL	2
5	2P3605	HOUSING ASSEM.	1
6	2D6642	BALL ( .250 in. Dia.)	2
6	4B9880	BALL ( .3127 in. Dia.)	1
7	5B5821	DOWEL	2
7	9S6958	BEARING	1
7	9S6932	HOUSING ASSEM.	1
8	4L4644	STUD	1
8	5B5821	DOWEL	2
9	9S6895	PISTON	1
10	9S6805	SPRING	12
11	9S6951	PISTON	1
12	9S6899	HOUSING	1
13	9S6949	MANIFOLD	1
14	6P6035	MANIFOLD ASSEM.	1
14	8S3426	DOWEL	1
14	4B9782	BALL	1
15	1H5403	BOLT	1
15	9S8413	WASHER	1
16	9S6918	SEAL	2
17	9S6913	SEAL	1
18	9S6914	SEAL	1
19	9S6924	BEARING	1
20	2M3974	RING	1
21	3S6874	RING	1
22	2D1523	RING	1
23	9S6893	HUB (24 Teeth)	1
24	8H3506	RING	4
25	9F7383	SEAL	1
26	5M2055	ROLLER ASSEM.	12
27	8S3553	PLATE (Serial No.)	1
28	7B3028	SCREW	2

2P2945 PLANETARY TRANSMISSION GROUP—Part 1  
 Part of 2P3701 Transmission Arrangement shown on Page 29  
 Note: 5P1144 Transmission Gasket Kit is available

2P2945 PLANETARY TRANSMISSION GROUP—Part 2  
 Part of 2P3701 Transmission Arrangement shown on Page 29

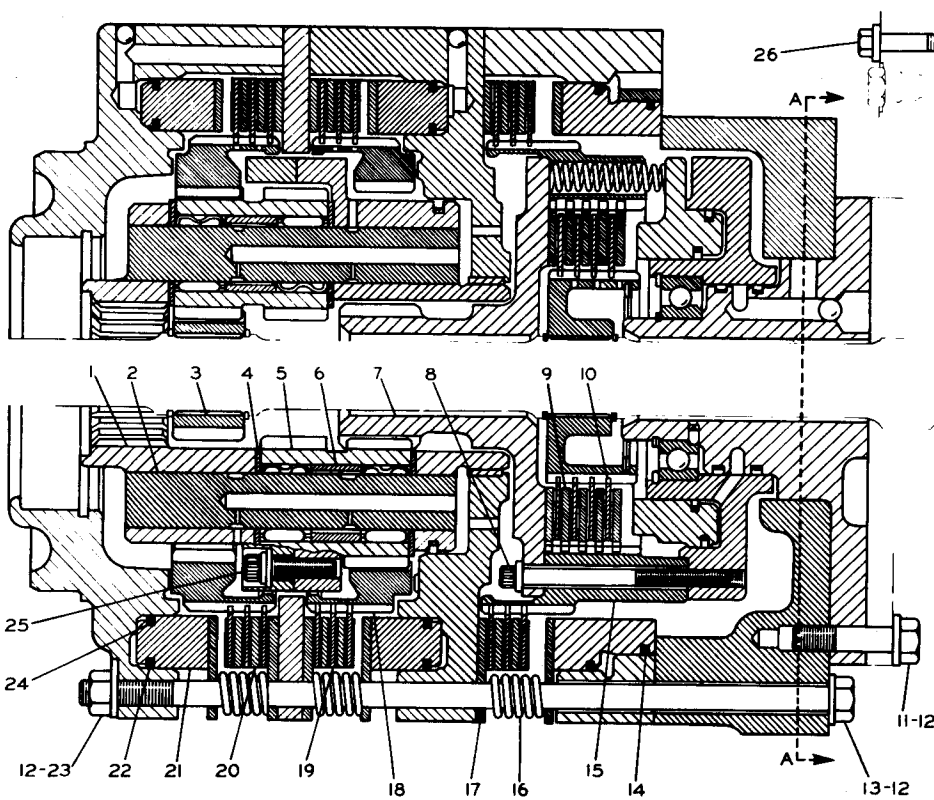

REF. NO.	PART NUMBER	DESCRIPTION	QTY
1	9S8416	CARRIER ASSEM. ....	1
2	9S2774	SHAFT .....	3
3	9S6894	GEAR ..... (19 Teeth)	1
4	2S1418	WASHER .....	12
5	9S2772	GEAR ..... (20 Teeth)	6
6	9S8410	SPACER .....	6
7	9S6898	GEAR ..... (23 Teeth)	1
8	2S5818	BOLT .....	8
9	9S5209	PLATE .....	5
10	2P3747	DISC ASSEM. ....	4
11	2A4639	BOLT .....	5
12	5M2894	WASHER .....	16
13	6J934	BOLT .....	5
14	8S3370	RING .....	1
15	9S6929	SEAL .....	1
16	3K5733	SPRING .....	18
17	9S5261	PLATE .....	6
18	9S6910	GEAR ..... (54 Teeth)	1
19	2P3719	DISC ASSEM. ....	9
20	9S5211	PLATE .....	6
21	2P3596	PISTON .....	2
22	9S6911	RING .....	3
23	1D4717	NUT .....	6
24	2P3597	RING .....	2
25	1T414	BOLT .....	6
25	9S5282	WASHER .....	6
26	1A5822	BOLT .....	2
26	2M849	WASHER .....	2

C INDICATES CHANGE

217166

POWER TRAIN-POWER TRANSMISSION UNIT

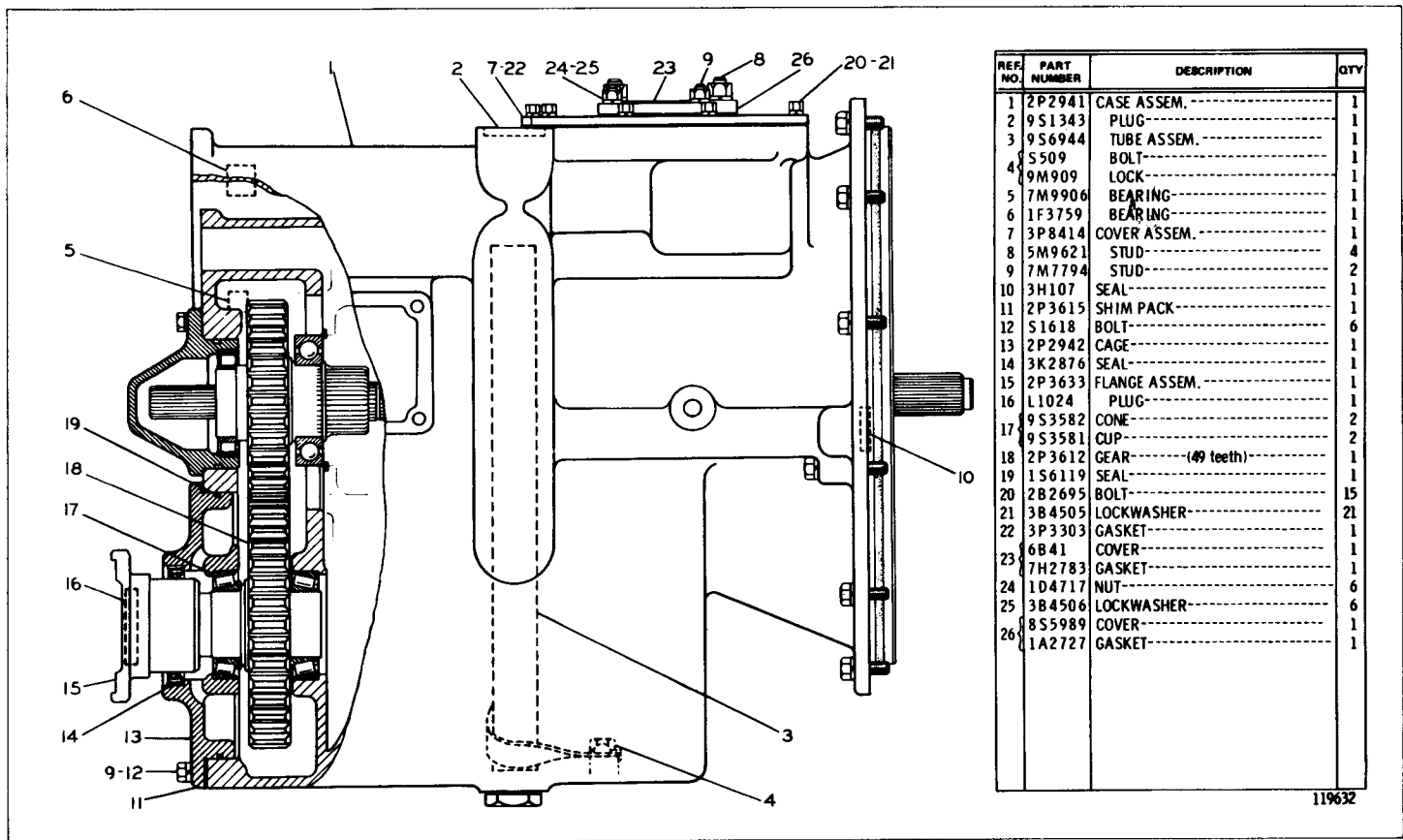

REF. NO.	PART NUMBER	DESCRIPTION	QTY
1	2P2941	CASE ASSEM.-----	1
2	9S1343	PLUG-----	1
3	9S6944	TUBE ASSEM.-----	1
4	S509	BOLT-----	1
4	9M909	LOCK-----	1
5	7M9906	BEARING-----	1
6	1F3759	BEARING-----	1
7	3P8414	COVER ASSEM.-----	1
8	5M9621	STUD-----	4
9	7M7794	STUD-----	2
10	3H107	SEAL-----	1
11	2P3615	SHIM PACK-----	1
12	S1618	BOLT-----	6
13	2P2942	CAGE-----	1
14	3K2876	SEAL-----	1
15	2P3633	FLANGE ASSEM.-----	1
16	L1024	PLUG-----	1
17	9S3582	CONE-----	2
17	9S3581	CUP-----	2
18	2P3612	GEAR----- (49 teeth)	1
19	1S6119	SEAL-----	1
20	2B2695	BOLT-----	15
21	3B4505	LOCKWASHER-----	21
22	3P3303	GASKET-----	1
23	6B41	COVER-----	1
23	7H2783	GASKET-----	1
24	1D4717	NUT-----	6
25	3B4506	LOCKWASHER-----	6
26	8S5989	COVER-----	1
26	1A2727	GASKET-----	1

119632

2P2946 TRANSFER GEAR GROUP—Part 1  
 Serial No. 79U1 to 79U1272 and 79U1307 inclusive  
 Part of 2P3701 Transmission Arrangement shown on Page 29

2P2946 TRANSFER GEAR GROUP—Part 2  
 Serial No. 79U1 to 79U1272 and 79U1307 inclusive  
 Part of 2P3701 Transmission Arrangement shown on Page 29

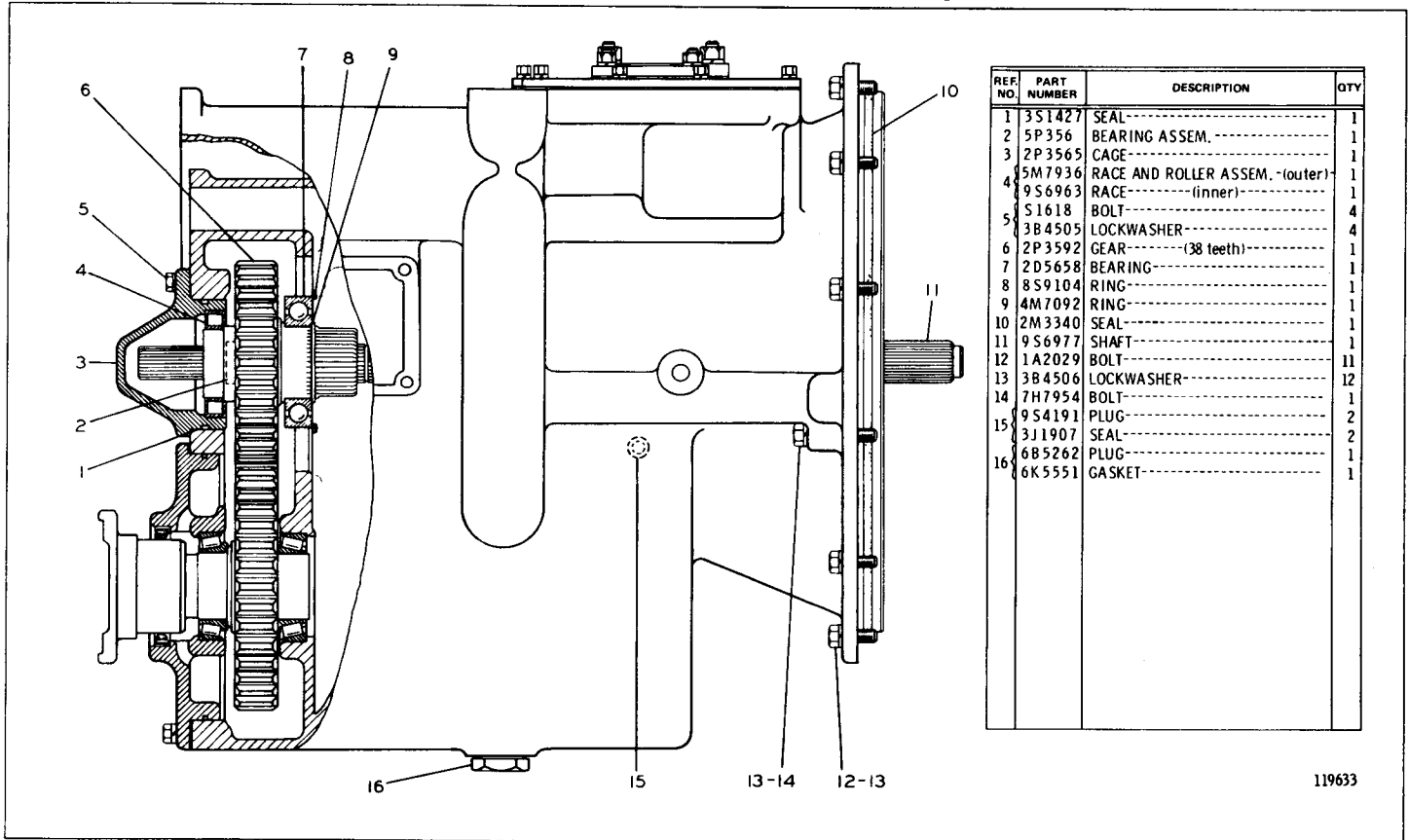

REF. NO.	PART NUMBER	DESCRIPTION	QTY
1	3S1427	SEAL-----	1
2	5P356	BEARING ASSEM.-----	1
3	2P3565	CAGE-----	1
4	5M7936	RACE AND ROLLER ASSEM. -(outer)-	1
	9S6963	RACE----- (inner)-	1
5	S1618	BOLT-----	4
	3B4505	LOCKWASHER-----	4
6	2P3592	GEAR----- (38 teeth)	1
7	2D5658	BEARING-----	1
8	8S9104	RING-----	1
9	4M7092	RING-----	1
10	2M3340	SEAL-----	1
11	9S6977	SHAFT-----	1
12	1A2029	BOLT-----	11
13	3B4506	LOCKWASHER-----	12
14	7H7954	BOLT-----	1
15	9S4191	PLUG-----	2
	3J1907	SEAL-----	2
	6B5262	PLUG-----	1
16	6K5551	GASKET-----	1

119633

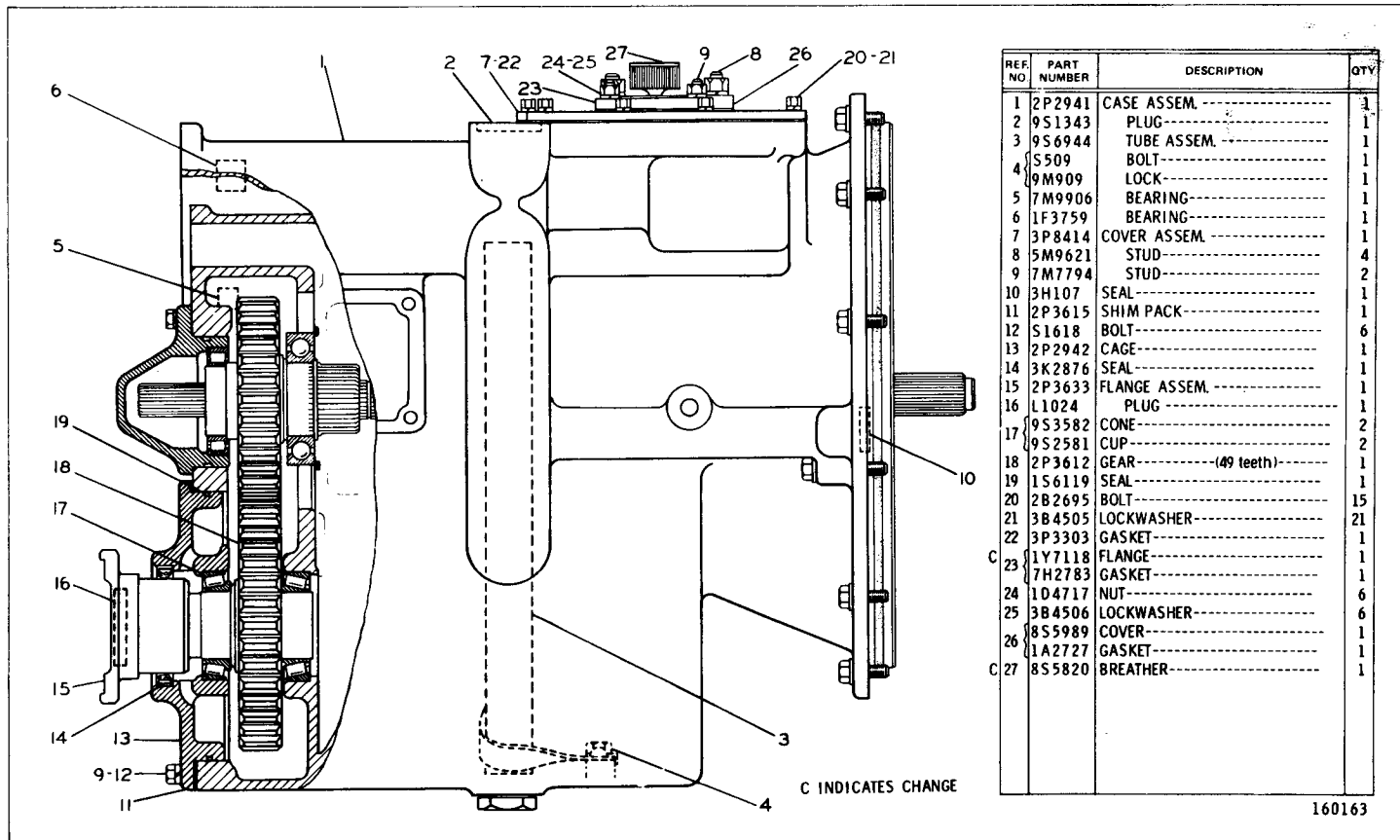

160163

2P2946 TRANSFER GEAR GROUP—Part 1  
 Serial No. 79U1273 to 79U1306 and 79U1308 to 79U3398 inclusive  
 Part of 2P3701 Transmission Arrangement shown on Page 29



**2P2946 TRANSFER GEAR GROUP—Part 2**  
 Serial No. 79U1273 to 79U1306 and 79U1308 to 79U3398 inclusive  
 Part of 2P3701 Transmission Arrangement shown on Page 29

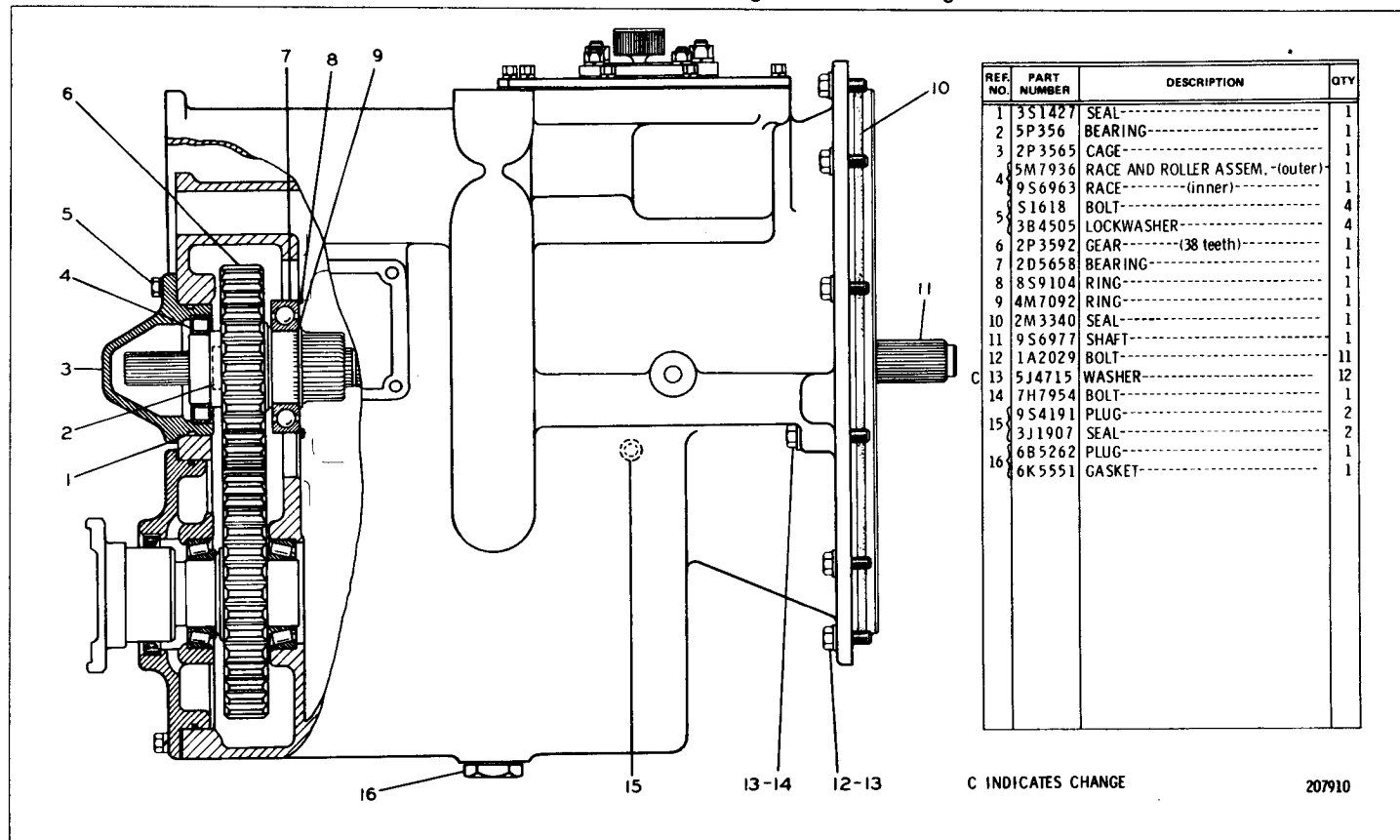

REF. NO.	PART NUMBER	DESCRIPTION	QTY
1	3S1427	SEAL-----	1
2	5P356	BEARING-----	1
3	2P3565	CAGE-----	1
4	5M7936	RACE AND ROLLER ASSEM. -(outer)-	1
4	9S6963	RACE------(inner)-----	1
5	S1618	BOLT-----	4
5	3B4505	LOCKWASHER-----	4
6	2P3592	GEAR----- (38 teeth)-----	1
7	2D5658	BEARING-----	1
8	8S9104	RING-----	1
9	4M7092	RING-----	1
10	2M3340	SEAL-----	1
11	9S6977	SHAFT-----	1
12	1A2029	BOLT-----	11
13	5J4715	WASHER-----	12
14	7H7954	BOLT-----	1
15	9S4191	PLUG-----	2
15	3J1907	SEAL-----	2
16	6B5262	PLUG-----	1
16	6K5551	GASKET-----	1

C INDICATES CHANGE

207910

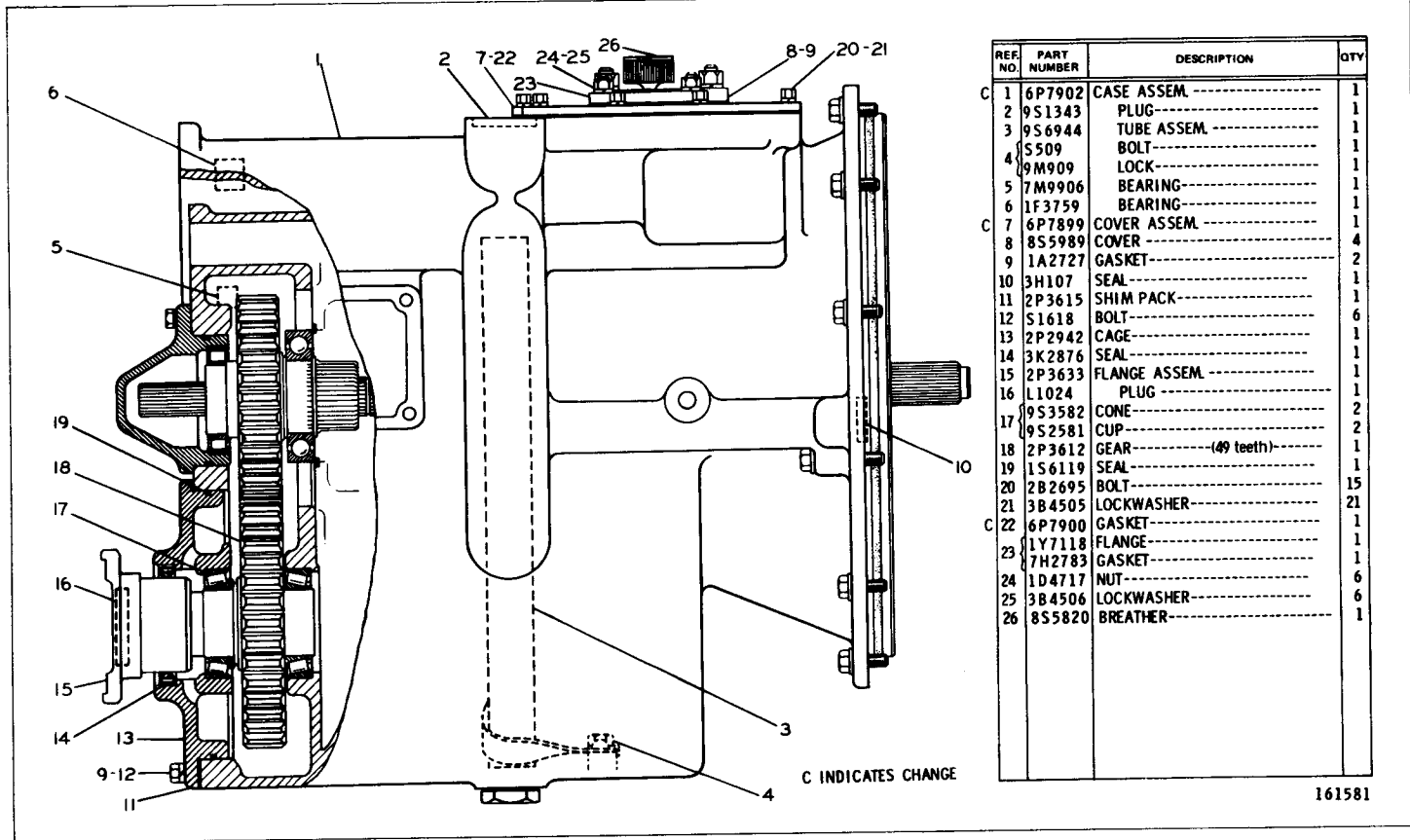

161581

2P2946 TRANSFER GEAR GROUP—Part 1  
 Serial No. 79U3399—Up and Test No. 11975 inclusive  
 Part of 2P3701 Transmission Arrangement shown on Page 29

2P2946 TRANSFER GEAR GROUP—Part 2  
 Serial No. 79U3399—Up and Test No. 11975 inclusive  
 Part of 2P3701 Transmission Arrangement shown on Page 29

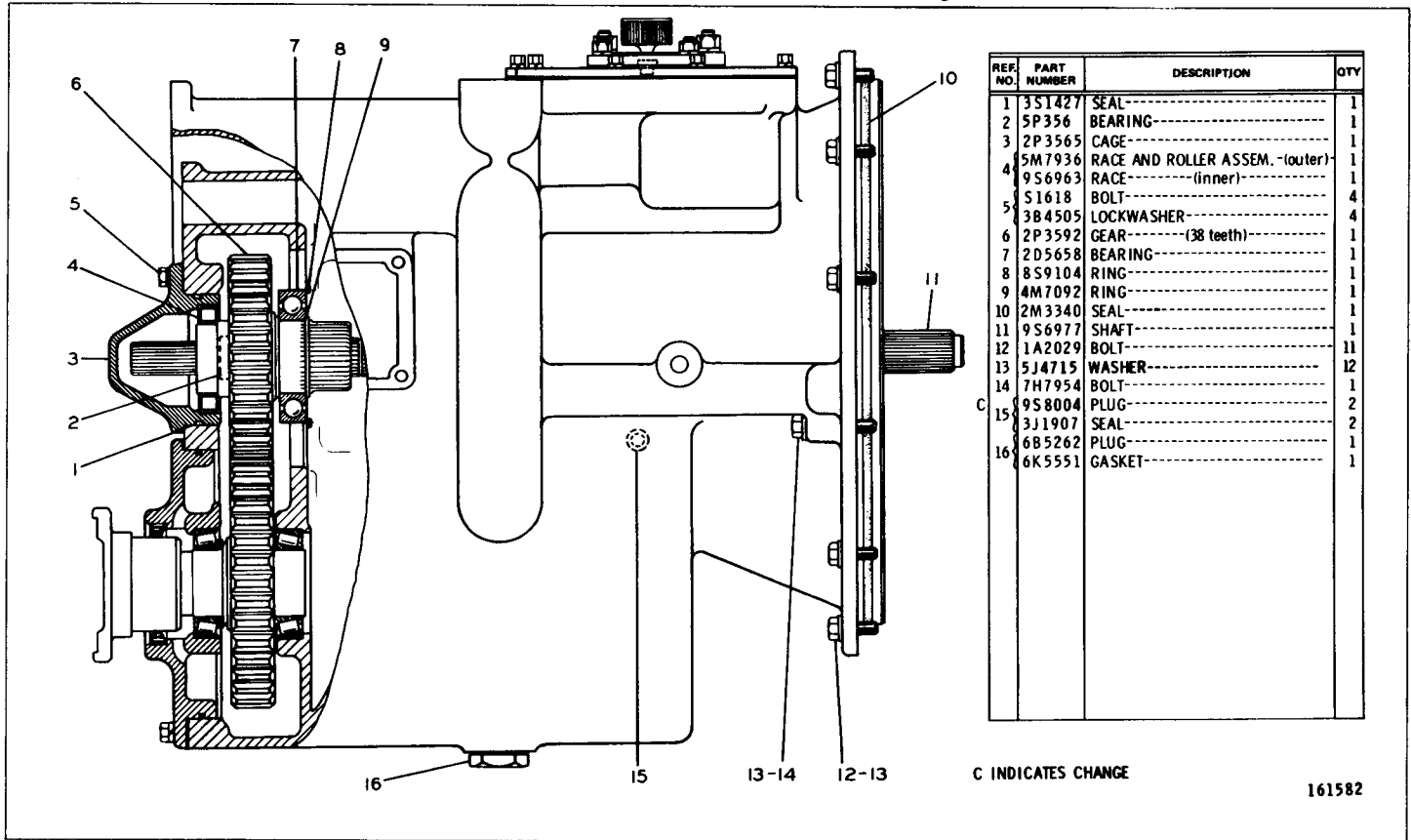

REF. NO.	PART NUMBER	DESCRIPTION	QTY
1	3S1427	SEAL-----	1
2	5P356	BEARING-----	1
3	2P3565	CAGE-----	1
4	5M7936	RACE AND ROLLER ASSEM.-(outer)-	1
4	9S6963	RACE-----(inner)-	1
5	51618	BOLT-----	4
5	3B4505	LOCKWASHER-----	4
6	2P3592	GEAR----- (38 teeth)-	1
7	2D5658	BEARING----- (38 teeth)-	1
8	8S9104	RING-----	1
9	4M7092	RING-----	1
10	2M3340	SEAL-----	1
11	9S6977	SHAFT-----	1
12	1A2029	BOLT-----	11
13	5J4715	WASHER-----	12
14	7H7954	BOLT-----	1
15	9S8004	PLUG-----	2
15	3J1907	SEAL-----	2
16	6B5262	PLUG-----	1
16	6K5551	GASKET-----	1

C INDICATES CHANGE

161582

POWER TRAIN-POWER TRANSMISSION UNIT

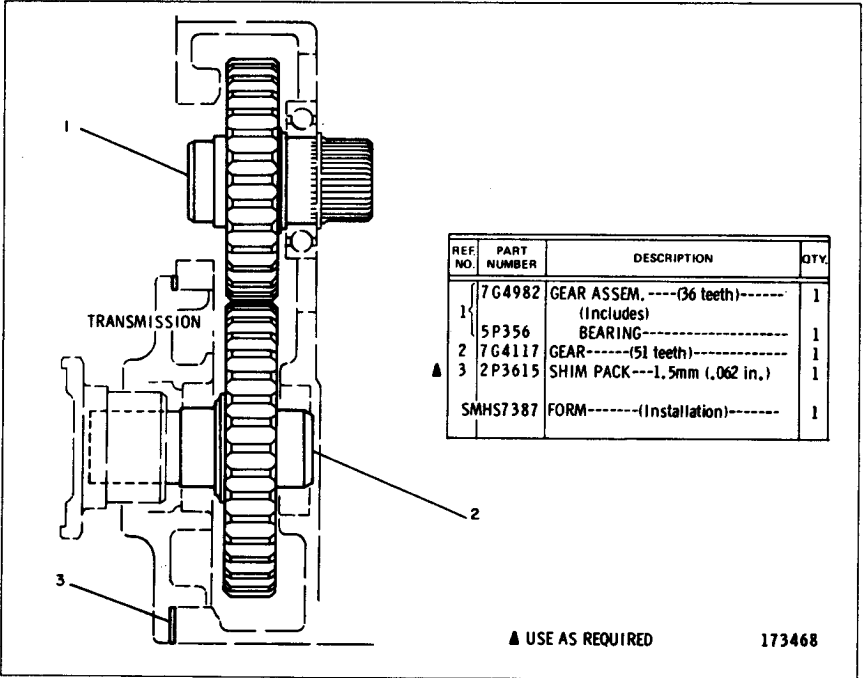

7G7144 TRANSFER GEAR GROUP—1.417:1 Ratio  
FIELD INSTALLATION

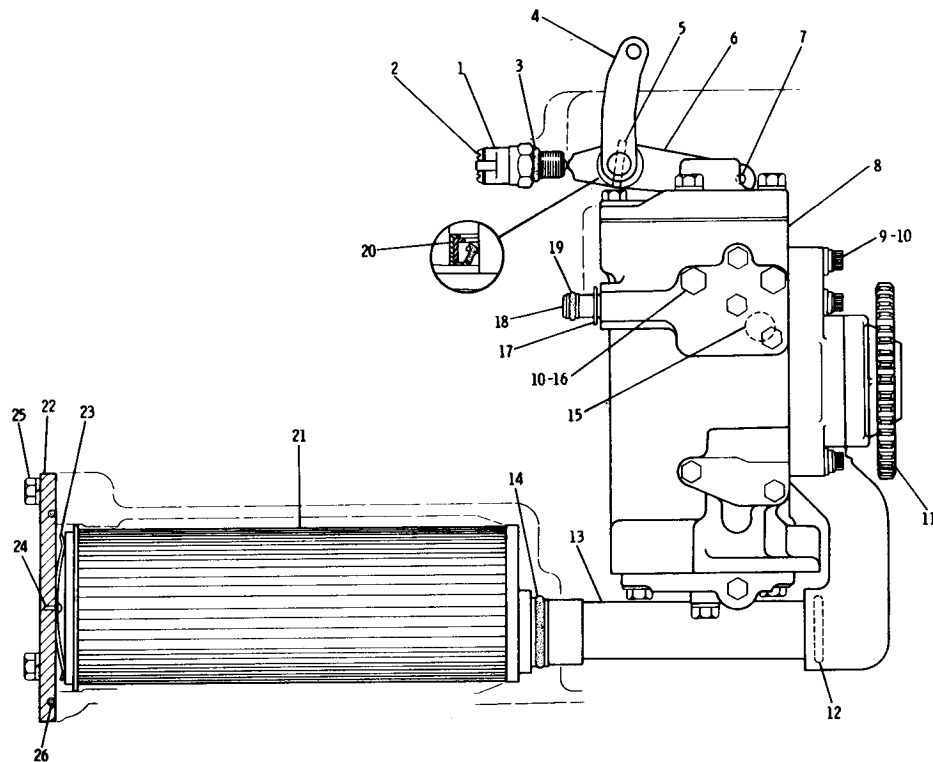

REF. NO.	PART NUMBER	DESCRIPTION	QTY
1	1P2564	SWITCH ASSEM. ----- (Includes)	1
2	9B7235	SCREW-----	2
	9B7233	LOCKWASHER-----	2
3	3J1907	SEAL-----	1
4	9S8400	LEVER ASSEM.-----	1
5	6H3956	PIN-----	1
6	9S8403	LEVER ASSEM.----- (Includes)	1
7	4S6525	DOWEL-----	1
8	3P3470	VALVE GROUP----- (Separate Illustration)	1
9	6L4783	BOLT-----	3
10	9M1974	WASHER-----	7
11	1P4165	PUMP GROUP----- (Separate Illustration)	1
12	2S4663	SEAL-----	1
13	2P3619	TUBE ASSEM.-----	1
14	8M5254	SEAL-----	1
15	9S6979	VALVE ASSEM.-----	1
16	3H5932	BOLT-----	4
17	4H1788	RING-----	1
18	9S8771	SLEEVE-----	1
19	6F5559	SEAL-----	2
20	4H1723	SEAL-----	1
21	2P3576	SCREEN-----	1
22	2P3603	COVER ASSEM.----- (Includes)	1
23	7S2962	WASHER-----	1
24	7B3028	SCREW-----	2
25	S1618	BOLT-----	3
26	3B4505	LOCKWASHER-----	3
	2H3934	SEAL-----	1

145372

3P3472 TRANSMISSION LUBRICATION SYSTEM CONTROL GROUP  
 Serial No. 79U1 to 2156, 2158 to 2161 and 79U2164 inclusive and Test No. 1 to 7269 inclusive  
 Part of 2P3701 Transmission Arrangement shown on Page 29. 3P3470 Valve and 1P4165 Pump  
 parts are shown on Pages 37 and 38

### 3P3472 TRANSMISSION LUBRICATION SYSTEM CONTROL GROUP

Serial No. 79U2157, 79U2162, 79U2163 and 79U2165 to 79U3398 inclusive and Test No. 7270 to 11974 inclusive  
 Part of 2P3701 Transmission Arrangement shown on Page 29. 3P3470 Valve and 1P4165 Pump parts are shown on Pages 37 and 38

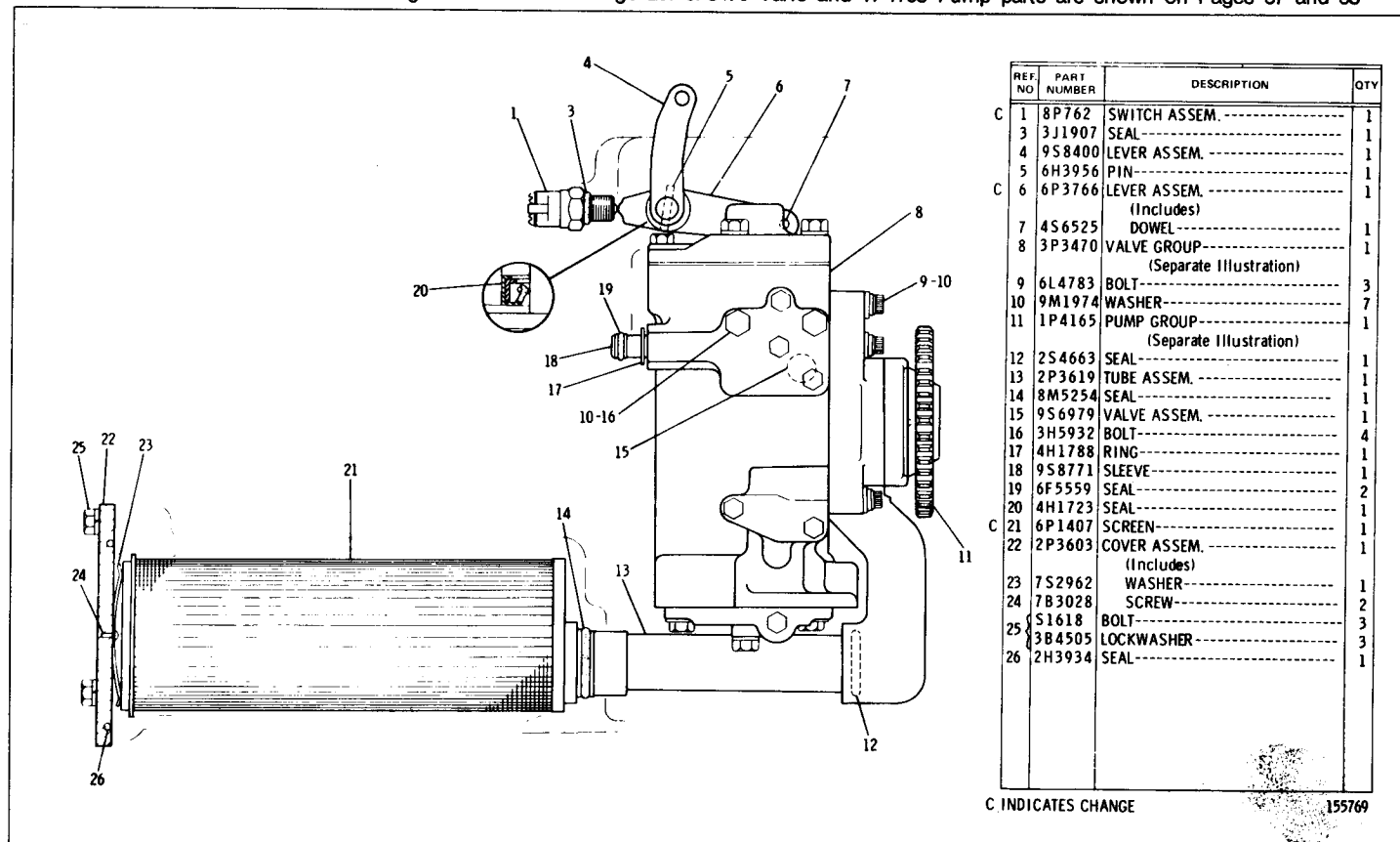

REF. NO.	PART NUMBER	DESCRIPTION	QTY
C 1	8P762	SWITCH ASSEM. -----	1
3	3J1907	SEAL -----	1
4	9S8400	LEVER ASSEM. -----	1
5	6H3956	PIN -----	1
C 6	6P3766	LEVER ASSEM. -----	1
		(Includes)	
7	4S6525	DOWEL -----	1
8	3P3470	VALVE GROUP -----	1
		(Separate Illustration)	
9	6L4783	BOLT -----	3
10	9M1974	WASHER -----	7
11	1P4165	PUMP GROUP -----	1
		(Separate Illustration)	
12	2S4663	SEAL -----	1
13	2P3619	TUBE ASSEM. -----	1
14	8M5254	SEAL -----	1
15	9S6979	VALVE ASSEM. -----	1
16	3H5932	BOLT -----	4
17	4H1788	RING -----	1
18	9S8771	SLEEVE -----	1
19	6F5559	SEAL -----	2
20	4H1723	SEAL -----	1
C 21	6P1407	SCREEN -----	1
22	2P3603	COVER ASSEM. -----	1
		(Includes)	
23	7S2962	WASHER -----	1
24	7B3028	SCREW -----	2
25	S1618	BOLT -----	3
25	3B4505	LOCKWASHER -----	3
26	2H3934	SEAL -----	1

C INDICATES CHANGE

155769

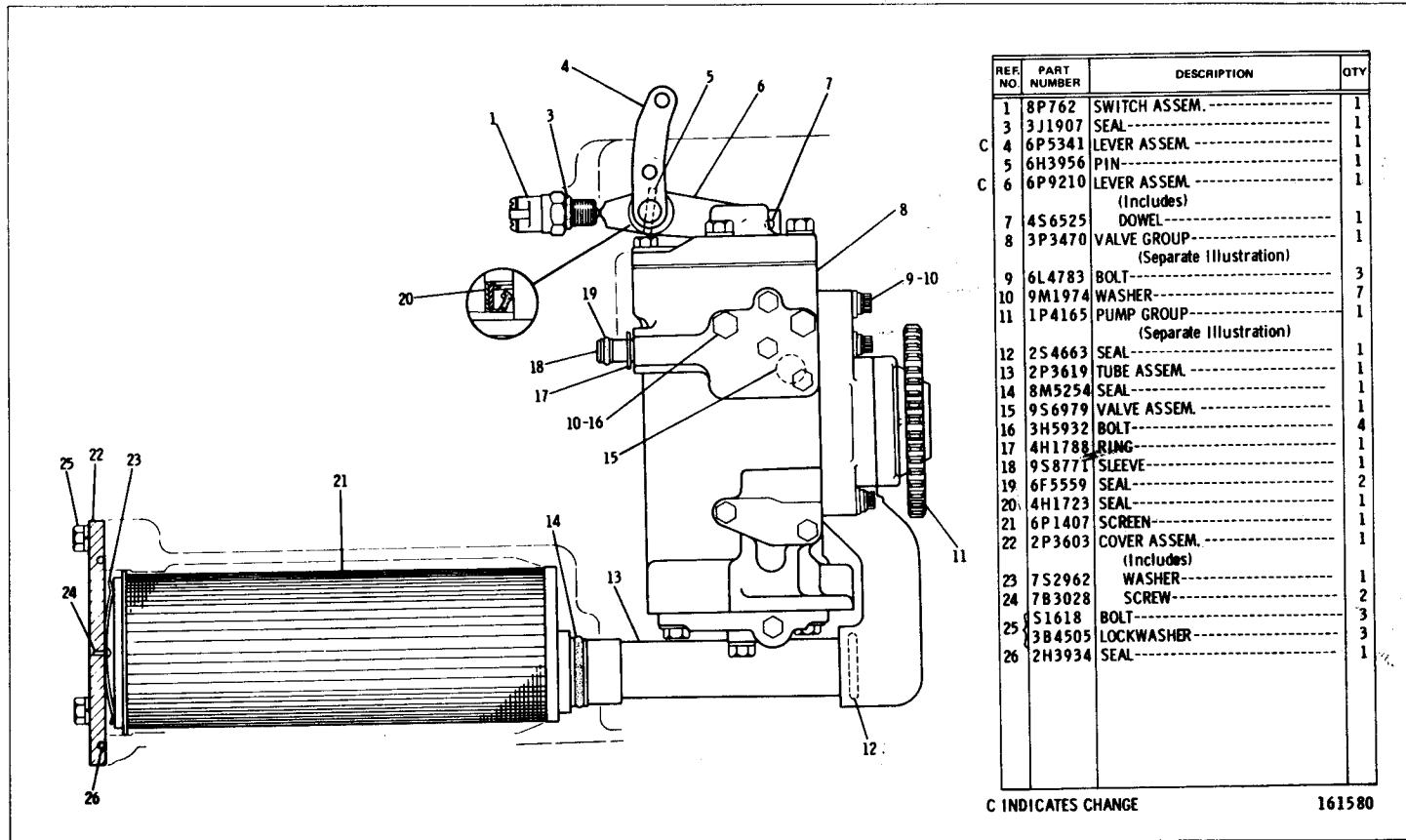

3P3472 TRANSMISSION LUBRICATION SYSTEM CONTROL GROUP  
 Serial No. 79U3399—Up and Test No. 11975  
 Part of 2P3701 Transmission Arrangement shown on Page 29  
 3P3470 Valve and 1P4165 Pump parts are shown on Pages 37 and 38

3P3470 SELECTOR AND PRESSURE CONTROL VALVE GROUP  
 Part of 3P3472 Transmission Lubrication System Control Group shown on Page 36

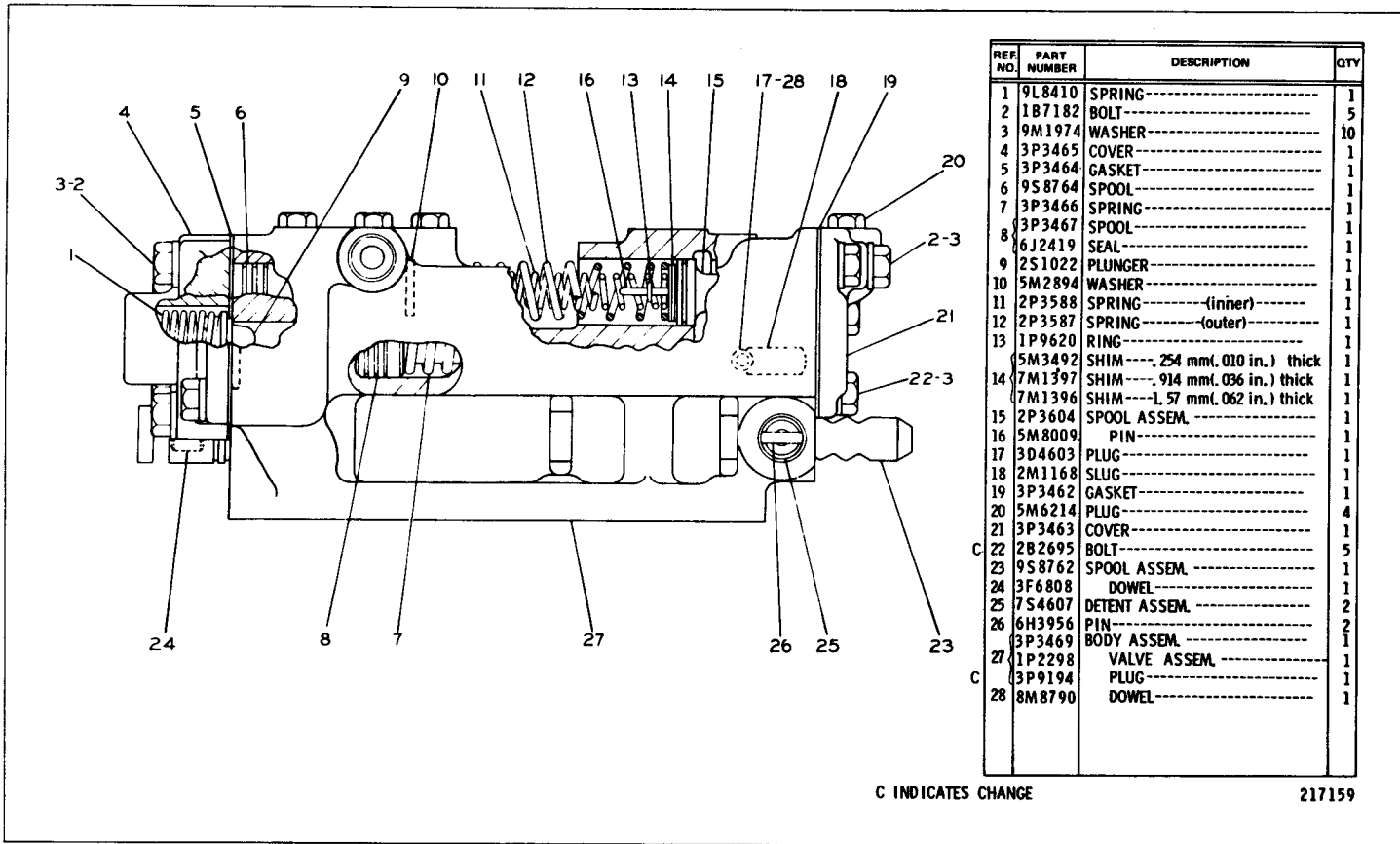

REF. NO.	PART NUMBER	DESCRIPTION	QTY
1	9L8410	SPRING-----	1
2	1B7182	BOLT-----	5
3	9M1974	WASHER-----	10
4	3P3465	COVER-----	1
5	3P3464	GASKET-----	1
6	9S8764	SPOOL-----	1
7	3P3466	SPRING-----	1
8	3P3467	SPOOL-----	1
8	6J2419	SEAL-----	1
9	2S1022	PLUNGER-----	1
10	5M2894	WASHER-----	1
11	2P3588	SPRING----- (inner)	1
12	2P3587	SPRING----- (outer)	1
13	1P9620	RING-----	1
14	5M3492	SHIM-----, 254 mm(.010 in.) thick	1
14	7M1397	SHIM-----, 914 mm(.036 in.) thick	1
14	7M1396	SHIM-----1.57 mm(.062 in.) thick	1
15	2P3604	SPOOL ASSEM.	1
16	5M8009	PIN-----	1
17	3D4603	PLUG-----	1
18	2M1168	SLUG-----	1
19	3P3462	GASKET-----	1
20	5M6214	PLUG-----	4
21	3P3463	COVER-----	1
C 22	2B2695	BOLT-----	5
23	9S8762	SPOOL ASSEM.	1
24	3F6808	DOWEL-----	1
25	7S4607	DETENT ASSEM.	2
26	6H3956	PIN-----	2
26	3P3469	BODY ASSEM.	1
27	1P2298	VALVE ASSEM.	1
C 27	3P9194	PLUG-----	1
28	8M8790	DOWEL-----	1

C INDICATES CHANGE

217159



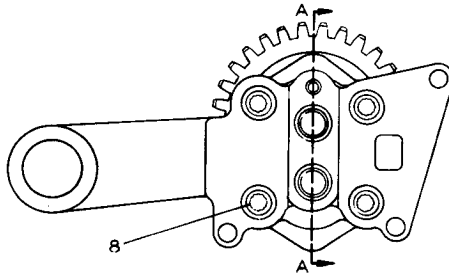
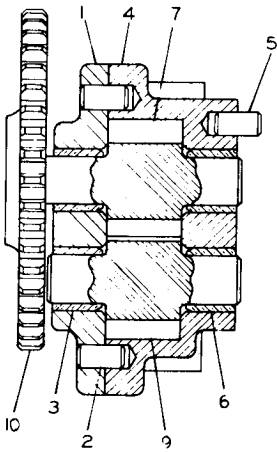

4	2P2927	BODY ASSEM. ....	1
5	4F2099	PIN .....	1
6	1P4170	BEARING .....	2
7	2P2928	GEAR ..... (10 Teeth)	1
8	6L4783	BOLT .....	4
	9M1974	WASHER .....	1
9	2P2929	GEAR ..... (10 Teeth)	1
10	1P4166	GEAR ..... (32 Teeth)	1

REF. NO.	PART NUMBER	DESCRIPTION	QTY
1	2P2925	COVER ASSEM. ....	1
2	4F2099	PIN .....	2
3	1P4170	BEARING .....	2

116242

1P4165 GEAR PUMP GROUP

Part of 3P3472 Transmission Lubrication System Control Group shown on Page 36

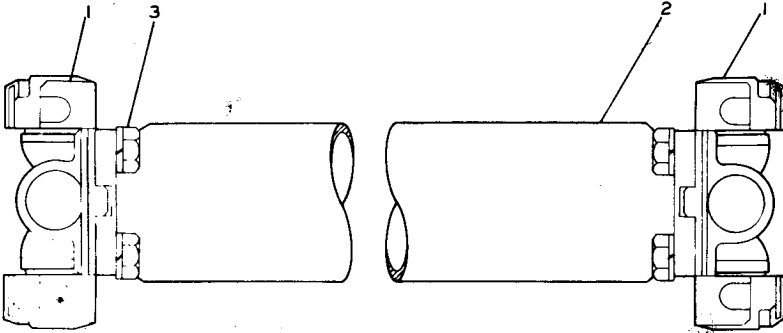

REF. NO.	PART NUMBER	DESCRIPTION	QTY
1	6S6902	SPIDER & BEARING ASSEM. ....	2
2	6S6867	TUBE ASSEM. ....	1

C	3	1A2343	BOLT .....	8
		3B4505	LOCKWASHER .....	8

C INDICATES CHANGE

217299

6S6770 UNIVERSAL JOINT GROUP

Part of 6S6707 Power Take-Off Drive Group shown on Page 39

6S6707 POWER TAKE-OFF DRIVE GROUP  
 Also part of 5G1012 Winch Drive Arrangement listed on Page 39A  
 6S6770 Joint parts are shown on Page 38. AN ATTACHMENT

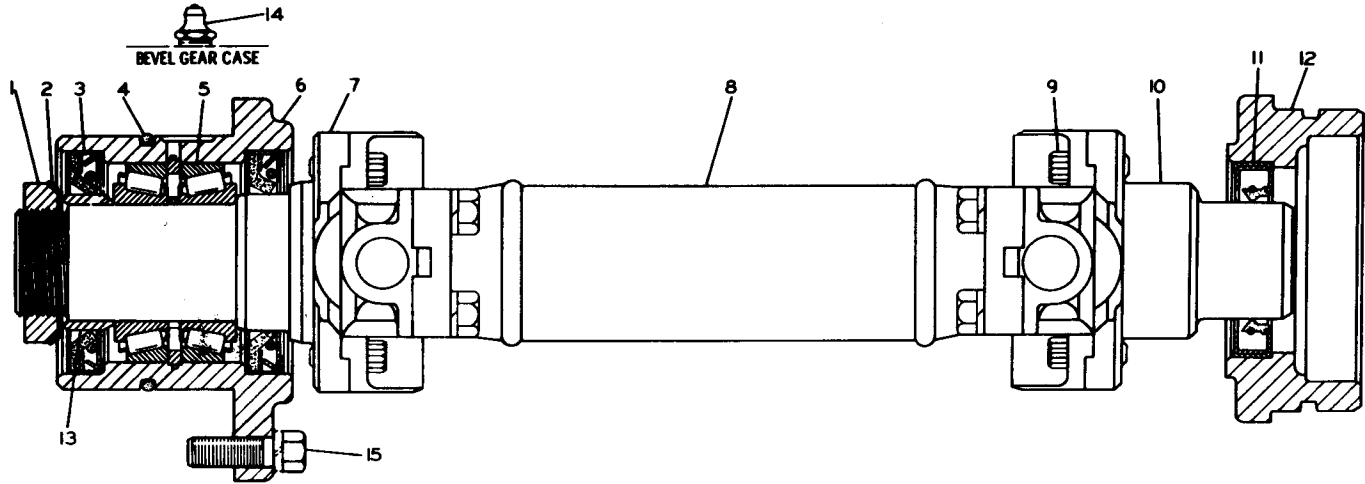

REF. NO.	PART NUMBER	DESCRIPTION	QTY
1	2H3777	NUT-----	1
2	5F8916	LOCK-----	1
3	6B5333	SEAL-----	2
C 4	1H7339	SEAL-----	1
5	5J9348	BEARING ASSEM.-----	1
6	6S6775	CAGE-----	1
7	6S6772	YOKE ASSEM.-----	1
8	6S6770	JOINT GROUP-----	1

(Separate Illustration)

9	5D8269	BOLT-----	8
C 10	5G2225	YOKE ASSEM.-----	1
11	3H1397	SEAL-----	1
12	6S6774	CAGE-----	1
13	6S8052	SPACER-----	1
14	3B8489	FITTING-----	1
C 15	S1588	BOLT-----	4

C INDICATES CHANGE

223543

CONSISTS OF:

PAGE

1	5S1011	PUMP AND LINES GROUP .....	39B
1	6S6707	POWER TAKE-OFF DRIVE GROUP .....	39

5G1012 WINCH DRIVE ARRANGEMENT  
AN ATTACHMENT

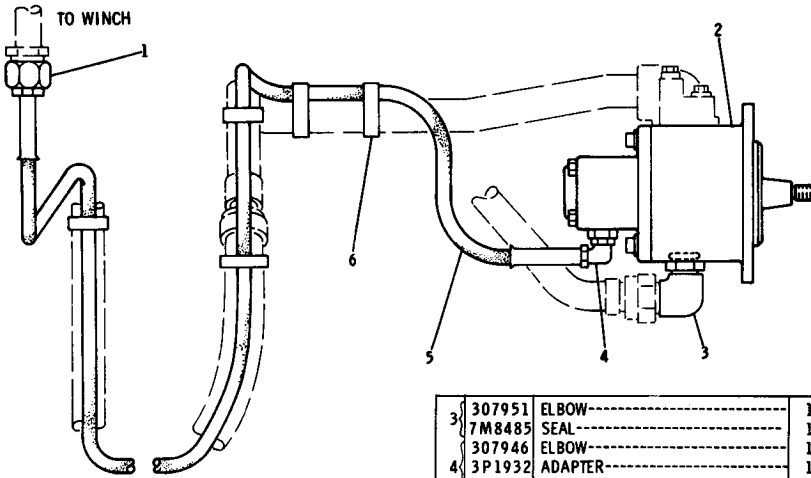

REF. NO.	PART NUMBER	DESCRIPTION	QTY
1	5P5005	REDUCER-----	1
2	3G5046	PUMP GROUP----- (Separate Illustration)	1

3	307951	ELBOW-----	1
	7M8485	SEAL-----	1
	307946	ELBOW-----	1
4	3P1932	ADAPTER-----	1
	3D2824	SEAL-----	1
5	3J7309	HOSE ASSEM.-----	1
6	7K1181	STRAP-----	8

167286

5G1011 PUMP AND LINES GROUP—Type 1  
Part of 5G1012 Winch Drive Arrangement listed on Page 39A  
3G5046 Pump parts are shown on Page 39B. AN ATTACHMENT

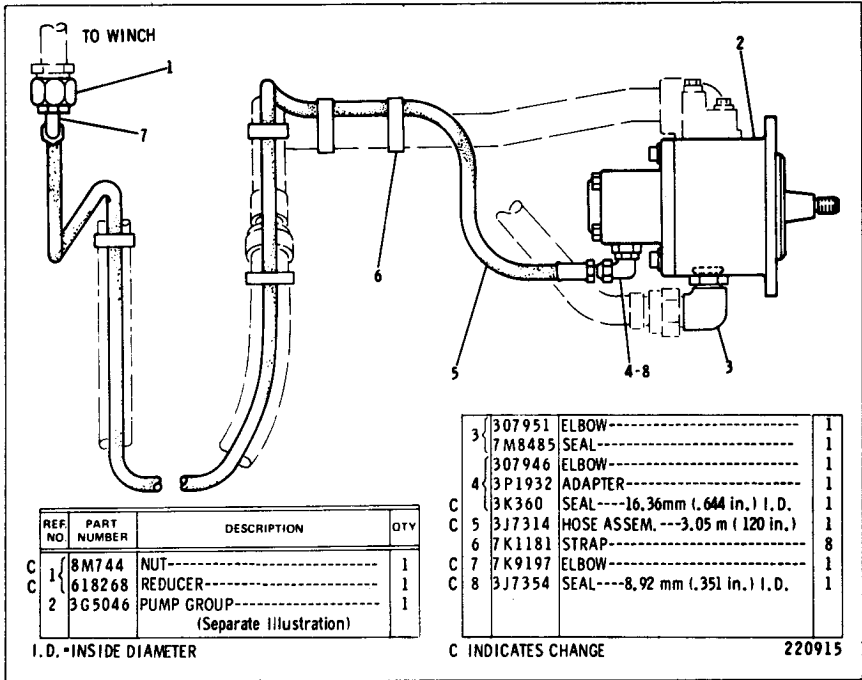

**5G1011 PUMP AND LINES GROUP—Type 2**  
 Part of 5G1012 Winch Drive Arrangement listed on Page 39A  
 AN ATTACHMENT

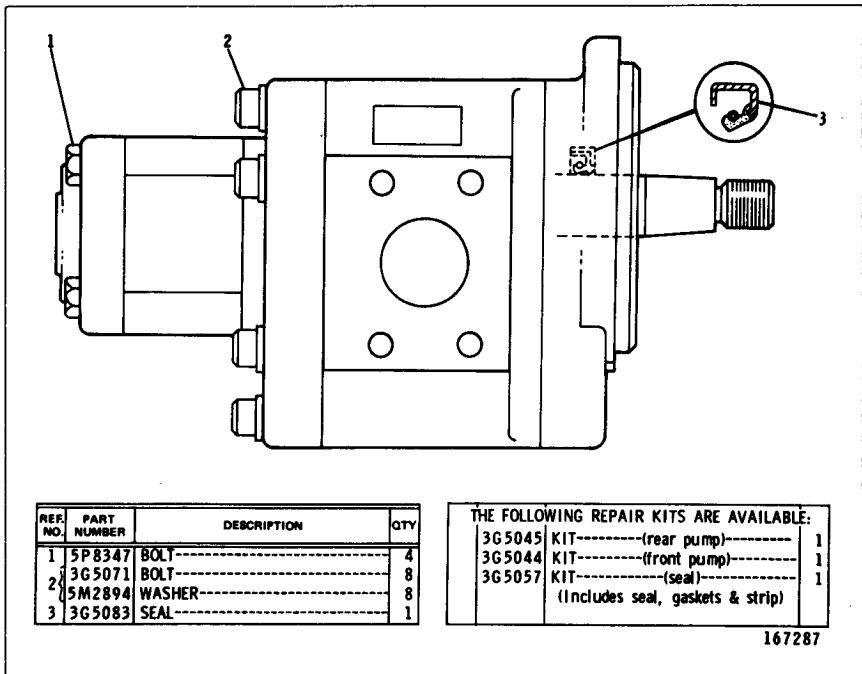

**3G5046 GEAR PUMP GROUP—Shimadzu Seiskusho**  
 Part of 5G1011 Pump and Lines Group shown on Pages 39A and 39B

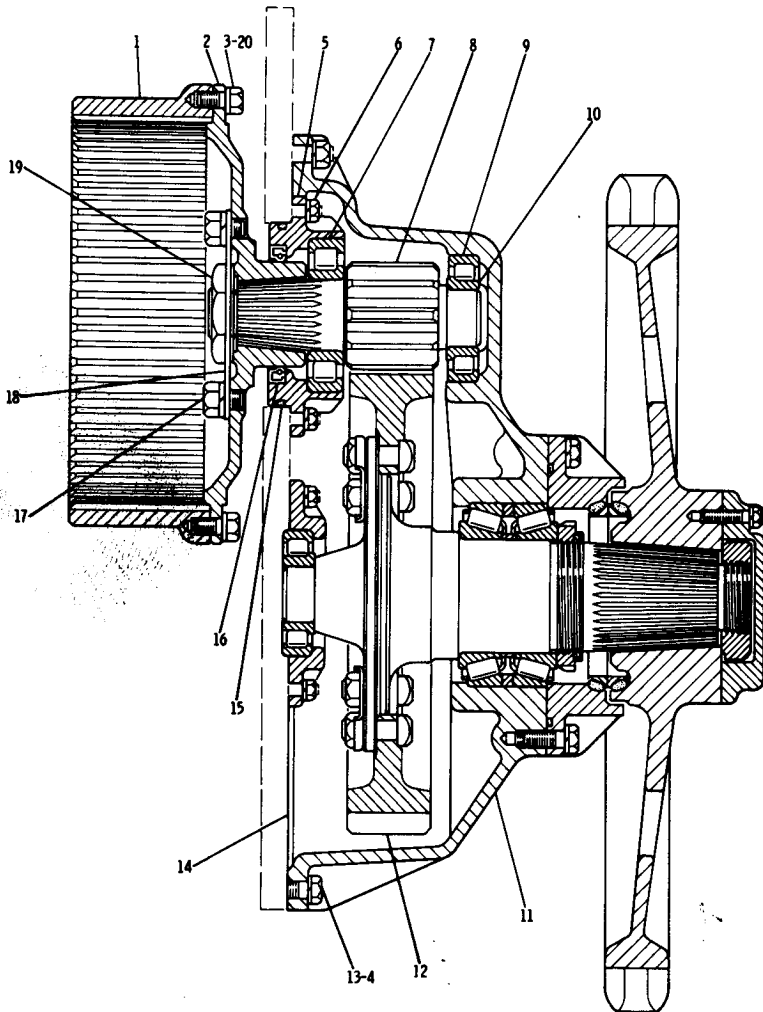

REF. NO.	PART NUMBER	DESCRIPTION	QTY
1	6S3203	DRUM-----	2
2	7K8238	FLANGE-----	2
3	6H1717	BOLT-----	28
4	3B4508	LOCKWASHER-----	40
5	6S6521	CAGE-----	2
6	1D4717	NUT-----	12
7	3B4506	LOCKWASHER-----	12
8	5K8591	RACE & ROLLER ASSEM. --(outer)--	2
9	3B3969	RACE----- (inner)-----	2
10	6S6512	PINION-----	2
11	3K5595	RACE & ROLLER ASSEM. --(outer)--	2
	3K5596	RACE----- (inner)-----	2
	6S3204	COVER-----	2
	1B5174	PLUG-----	4

12	6S3177	GEAR----- (56 teeth)-----	2
13	7B3235	BOLT-----	16
	1D4719	NUT-----	24
14	7M7260	LIQUID GASKET-----	
15	2H3935	SEAL-----	2
16	3K9619	SEAL-----	2
17	1H9456	BOLT-----	4
	3B4510	LOCKWASHER-----	4
C 18	9K4058	LOCK-----	2
	2J5815	NUT-----	2
19	2B6325	GASKET-----	2
C 20	2M849	WASHER-----	28

NOTE: QUANTITIES SHOWN ARE THOSE REQUIRED FOR BOTH R. H. & L. H. SIDES  
C INDICATES CHANGE

157558

6S3604 FINAL DRIVE—Part 1  
Serial No. 79U1 to 79U4009 inclusive

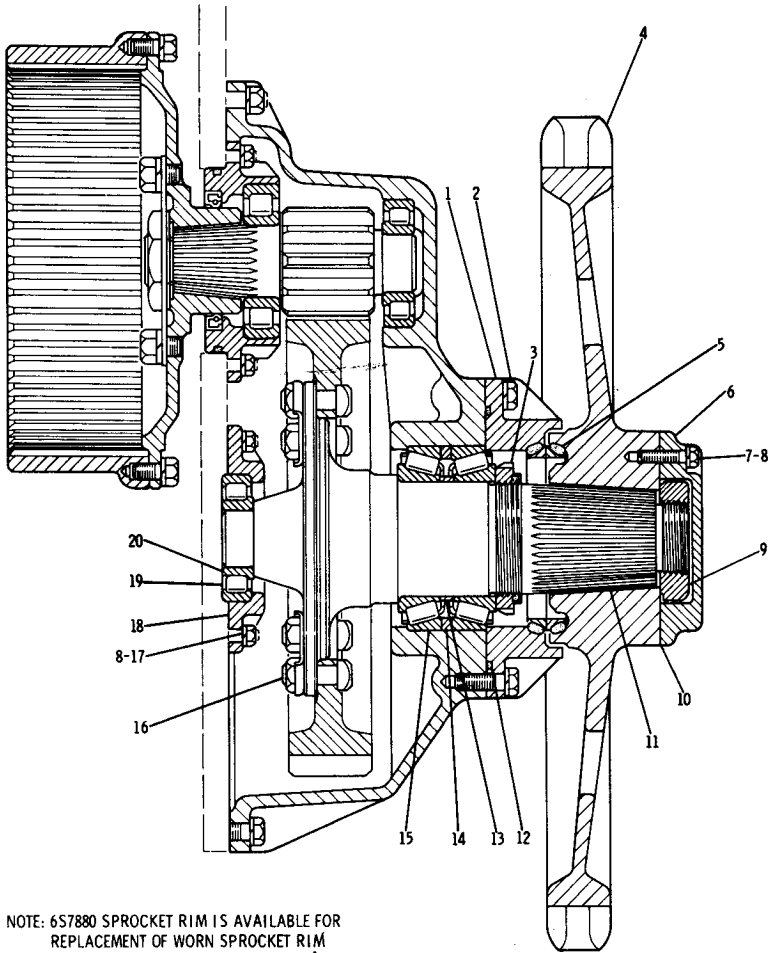

NOTE: 6S7880 SPROCKET RIM IS AVAILABLE FOR REPLACEMENT OF WORN SPROCKET RIM

REF NO	PART NUMBER	DESCRIPTION	QTY
1	6S3192	RETAINER-----	2
2	7B3235	BOLT-----	12
	3B4508	LOCKWASHER-----	12
3	6S4531	LOCKNUT-----	2
4	6S3169	SPROCKET-----	2
5	1P7249	SEAL GROUP-----	2
		(Includes)	
	1P7239	RING-----	2
6	6S4520	LOCK-----	2
7	S1591	BOLT-----	6
8	3B4506	LOCKWASHER-----	18
9	9B2962	NUT-----	2
	6S4535	GASKET-----	2
10	7M7260	LIQUID GASKET-----	2

11	6S3188	SHAFT-----	2
12	1H8278	SEAL-----	2
13	2P8386	SPACER-----	2
14	2P8387	SPACER-----	2
15	1P3934	CUP-----	4
	1P3935	CONE-----	4
16	3K3815	BOLT-----	20
	6B6683	NUT-----	20
	6S3210	LOCK-----	10
17	1D4717	NUT-----	12
18	6S3194	CAGE-----	2
19	6S2905	RACE & ROLLER ASSEM. --(outer)--	2
20	3B3967	RACE----- (inner)	2

NOTE: QUANTITIES SHOWN ARE THOSE REQUIRED FOR BOTH R. H. & L. H. SIDES

155323

6S3604 FINAL DRIVE GROUP—Part 2  
Serial No. 79U1 to 79U4009 inclusive

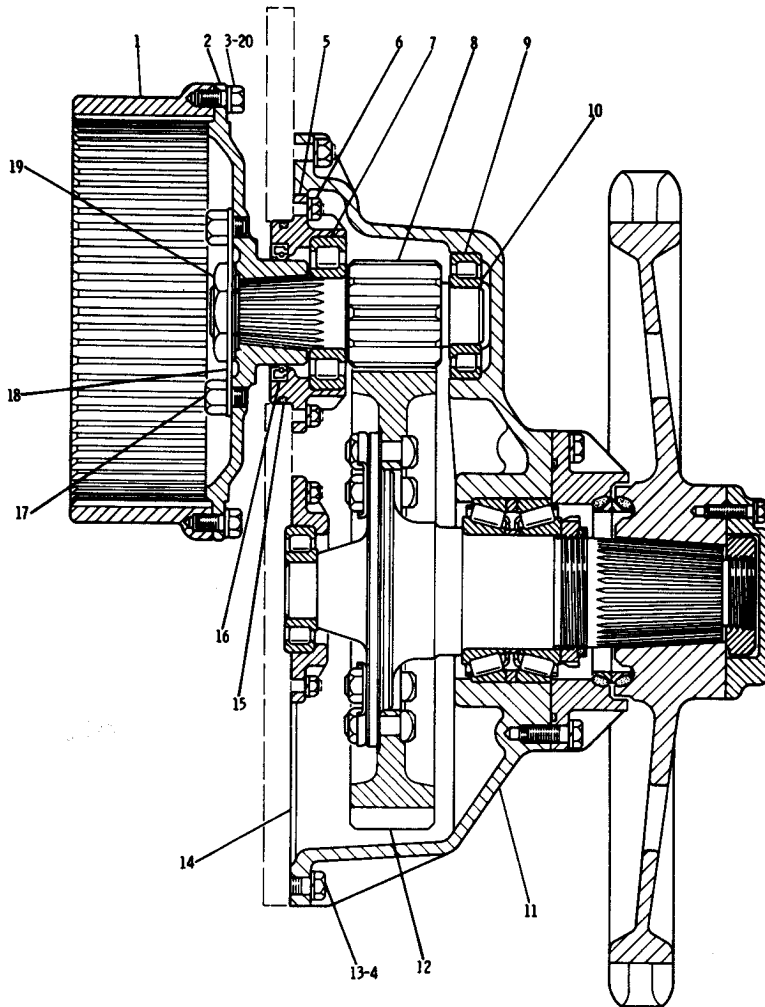

REF. NO.	PART NUMBER	DESCRIPTION	QTY
1	6S3203	DRUM-----	2
2	7K8238	FLANGE-----	2
3	6H1717	BOLT-----	28
4	3B4508	LOCKWASHER-----	40
5	6S6521	CAGE-----	2
6	1D4717	NUT-----	12
6	3B4506	LOCKWASHER-----	12
7	5K8591	RACE & ROLLER ASSEM. --(outer)--	2
7	3B3969	RACE----- (inner)-----	2
8	6S6512	PINION-----	2
9	3K5595	RACE & ROLLER ASSEM. --(outer)--	2
10	3K5596	RACE----- (inner)-----	2
10	6S3204	COVER-----	2
11	1B5174	PLUG-----	4
12	6S3177	GEAR----- (56 teeth)-----	2
13	7B3235	BOLT-----	16
13	1F7958	NUT-----	24
14	7M7260	LIQUID GASKET-----	2
15	2H3935	SEAL-----	2
16	3K9619	SEAL-----	2
17	1H9456	BOLT-----	4
18	9K4058	LOCK-----	2
19	2J5815	NUT-----	2
19	2B6325	GASKET-----	2
20	2M849	WASHER-----	28

NOTE: QUANTITIES SHOWN ARE THOSE REQUIRED FOR BOTH R. H. & L. H. SIDES  
C INDICATES CHANGE

217150

6S3604 FINAL DRIVE GROUP—Part 1  
Serial No. 79U4010 to 4051 and 79U4057 to 79U4109 inclusive

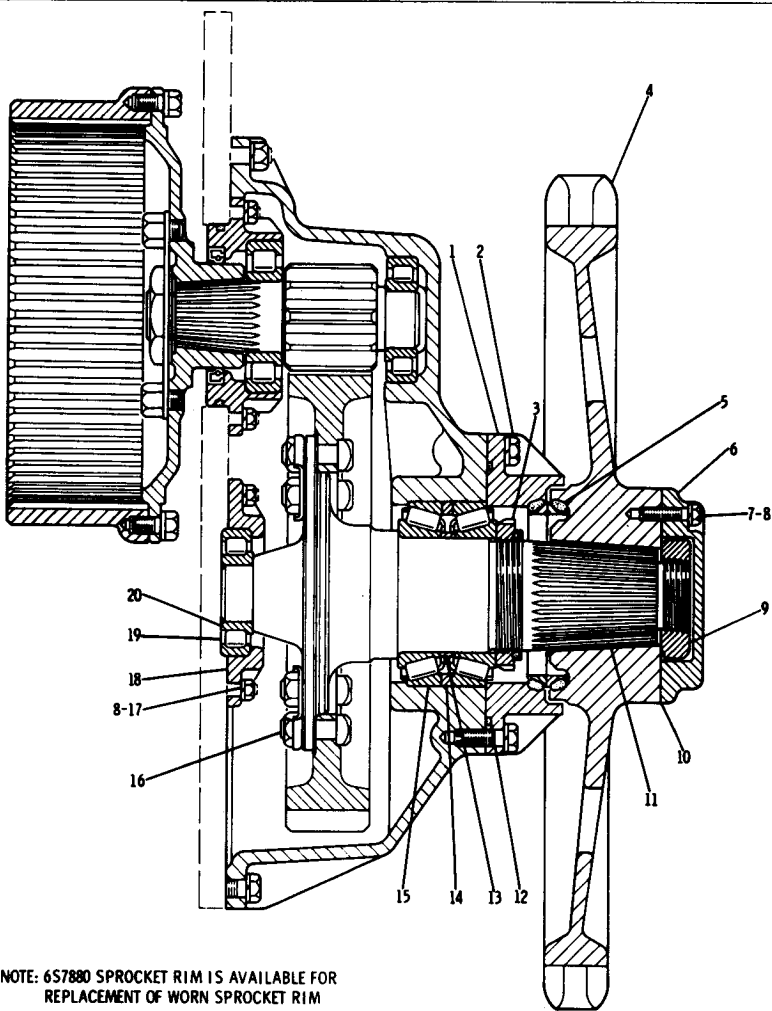

NOTE: 6S7880 SPROCKET RIM IS AVAILABLE FOR REPLACEMENT OF WORN SPROCKET RIM

REF. NO.	PART NUMBER	DESCRIPTION	QTY
1	6S3192	RETAINER-----	2
2	7B3235	BOLT-----	12
	3B4508	LOCKWASHER-----	12
3	6S4531	LOCKNUT-----	2
C 4	6S3169	SPROCKET-----	2
	1P7249	SEAL GROUP-----	2
5	1P7239	(Includes) RING-----	2
C 6	6S4520	LOCK-----	2
7	51591	BOLT-----	6
C 8	3B4506	LOCKWASHER-----	18
	9B2962	NUT-----	2
9	6S4535	GASKET-----	2
10	7M7260	LIQUID GASKET-----	

C INDICATES CHANGE

11	5G319	SHAFT-----	2
12	1H8278	SEAL-----	2
13	5P7208	SPACER-----	2
14	2P8387	SPACER-----	2
	1P3934	CUP-----	4
15	1P3935	CONE-----	4
	3K3815	BOLT-----	20
16	6B6683	NUT-----	20
	6S3210	LOCK-----	10
17	1D4717	NUT-----	12
18	6S3194	CAGE-----	2
19	6S2905	RACE & ROLLER ASSEM.--(outer)--	2
20	3B3967	RACE-----	2
		-----	2
		-----	2

NOTE: QUANTITIES SHOWN ARE THOSE REQUIRED FOR BOTH R. H. & L. H. SIDES

169737

6S3604 FINAL DRIVE GROUP—Part 2  
Serial No. 79U4010 to 4051 & 79U4057 to 79U4109 inclusive



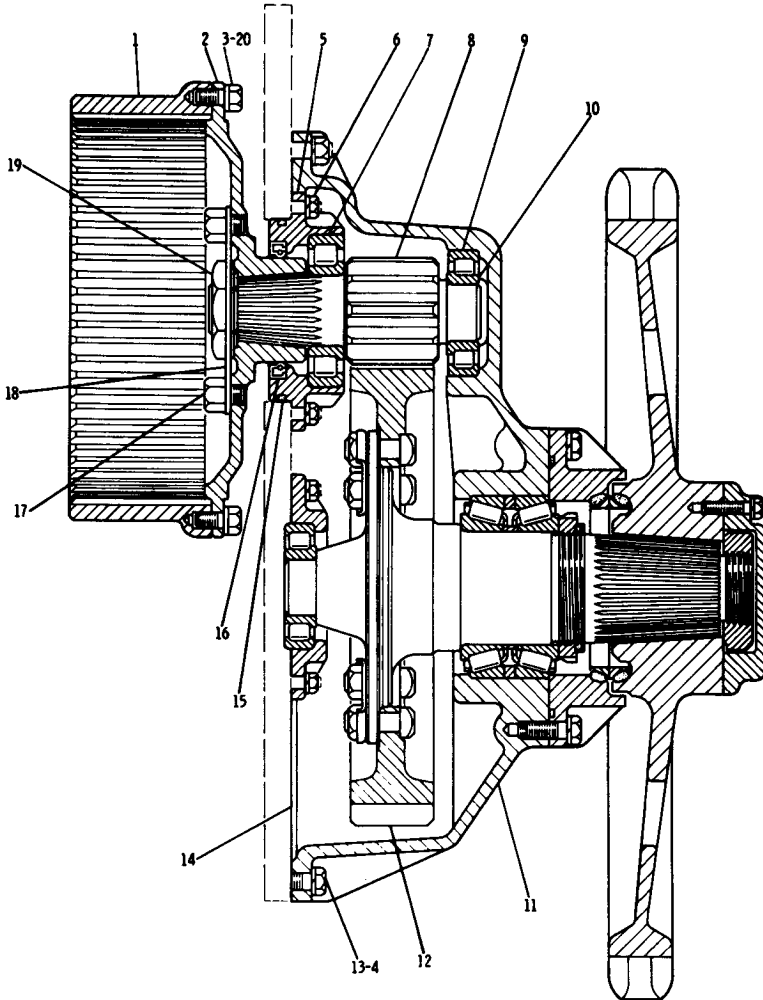

REF. NO.	PART NUMBER	DESCRIPTION	QTY
1	6S3203	DRUM-----	2
2	7K8238	FLANGE-----	2
3	6H1717	BOLT-----	28
4	3B4508	LOCKWASHER-----	40
5	6S6921	CAGE-----	2
	1D4717	NUT-----	12
6	3B4506	LOCKWASHER-----	12
	5K8591	RACE & ROLLER ASSEM. --(outer)--	2
7	3B3969	RACE----- (inner)	2
8	6S6512	PINION-----	2
9	3K5595	RACE & ROLLER ASSEM. --(outer)--	2
10	3K5596	RACE----- (inner)	2
	6S3204	COVER-----	2
11	1B5174	PLUG-----	4

12	6S3177	GEAR----- (56 teeth)-----	2
	7B3235	BOLT-----	16
13	1F7958	NUT-----	24
14	7M7260	LIQUID GASKET-----	
15	2H3935	SEAL-----	2
16	3K9619	SEAL-----	2
17	1H9456	BOLT-----	4
18	9K4058	LOCK-----	2
19	2J5815	NUT-----	2
	5G695	SEAL-----	2
20	2M849	WASHER-----	28

NOTE: QUANTITIES SHOWN ARE THOSE REQUIRED FOR BOTH R. H. & L. H. SIDES  
C INDICATES CHANGE

217152

6S3604 FINAL DRIVE GROUP—Part 1  
Serial No. 79U4110—Up

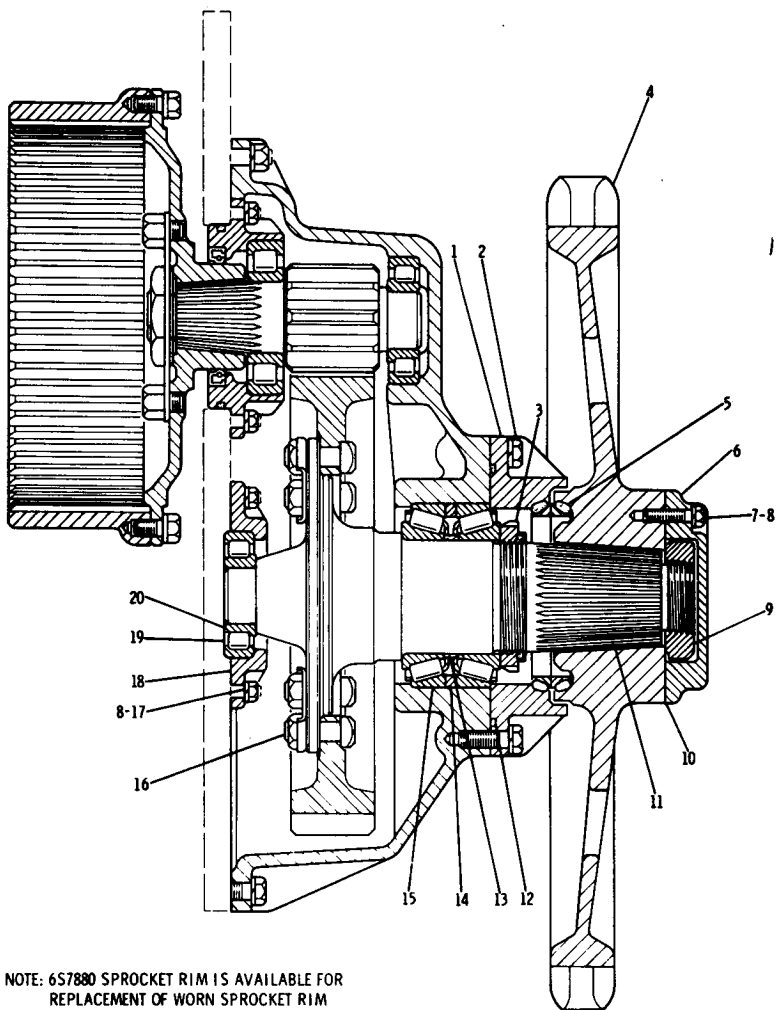

NOTE: 6S7880 SPROCKET RIM IS AVAILABLE FOR REPLACEMENT OF WORN SPROCKET RIM

REF. NO.	PART NUMBER	DESCRIPTION	QTY
1	6S3192	RETAINER-----	2
2	7B3235	BOLT-----	12
	3B4508	LOCKWASHER-----	12
3	6S4531	LOCKNUT-----	2
C 4	6S8270	SPROCKET-----	2
	1P7249	SEAL GROUP-----	2
5	(Includes)		
	1P7239	RING-----	2
C 6	6S6816	LOCKNUT-----	2
C 7	S1591	BOLT-----	2
8	3B4506	LOCKWASHER-----	24
9	9B2962	NUT-----	2
	6S4535	GASKET-----	2
10	7M7260	LIQUID GASKET-----	2

C INDICATES CHANGE

C 11	5G319	SHAFT-----	2
12	1H8278	SEAL-----	2
C 13	5P7208	SPACER-----	2
14	2P8387	SPACER-----	2
15	1P3934	CUP-----	4
	1P3935	CONE-----	4
16	3K3815	BOLT-----	20
	6B6683	NUT-----	20
17	6S3210	LOCK-----	10
	1D4717	NUT-----	12
18	6S3194	CAGE-----	2
19	6S2905	RACE & ROLLER ASSEM--(outer)--	2
20	3B3967	RACE----- (inner)-----	2

NOTE: QUANTITIES SHOWN ARE THOSE REQUIRED FOR BOTH R. H. & L. H. SIDES

217151

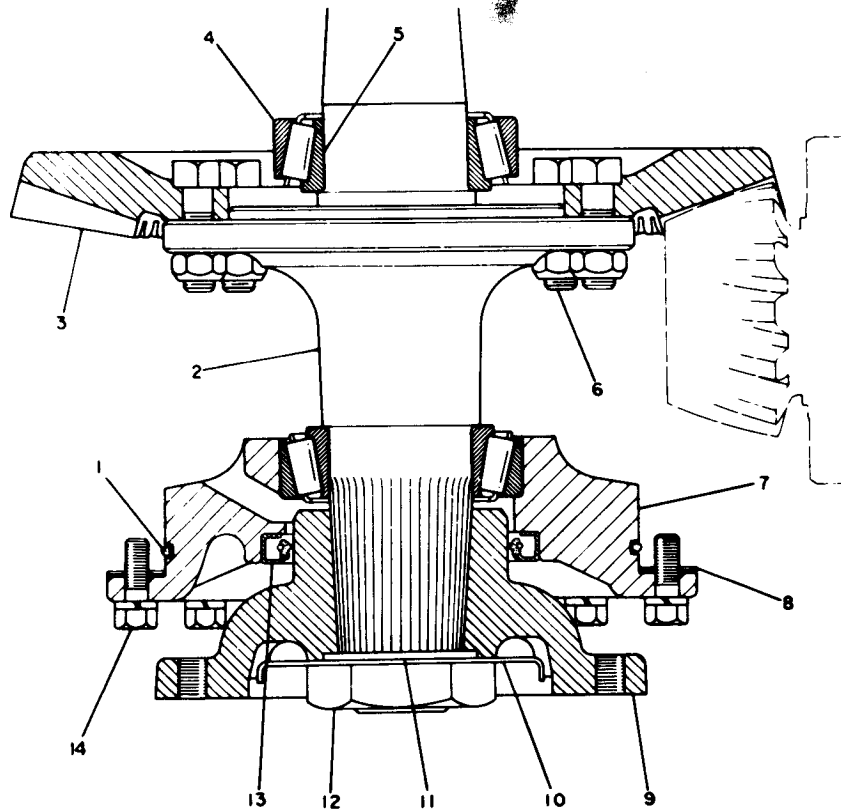

REF. NO.	PART NUMBER	DESCRIPTION	QTY
1	2K2939	SEAL-----	2
2	6S3116	SHAFT----- (bevel gear)-----	1
3	6S3250	GEAR----- (bevel 47 teeth)-----	1
4	7J8894	CUP-----	2
5	7J8893	CONE-----	2
6	2K4830	BOLT-----	10
	2K564	NUT-----	10
7	6S3181	CAGE-----	2
8	6S3159	SHIM PACK-----	4
9	6S3249	COUPLING-----	2
10	6S6614	LOCK-----	2
11	5G695	GASKET-----	2
12	L2341	NUT-----	2
13	3K9619	SEAL-----	2
14	1A2029	BOLT-----	16
	3B4506	LOCKWASHER-----	16

C INDICATES CHANGE

217168

BEVEL GEAR (6S3530 N/S)—Part 1

### BEVEL GEAR (6S3530 N/S) -Part 2

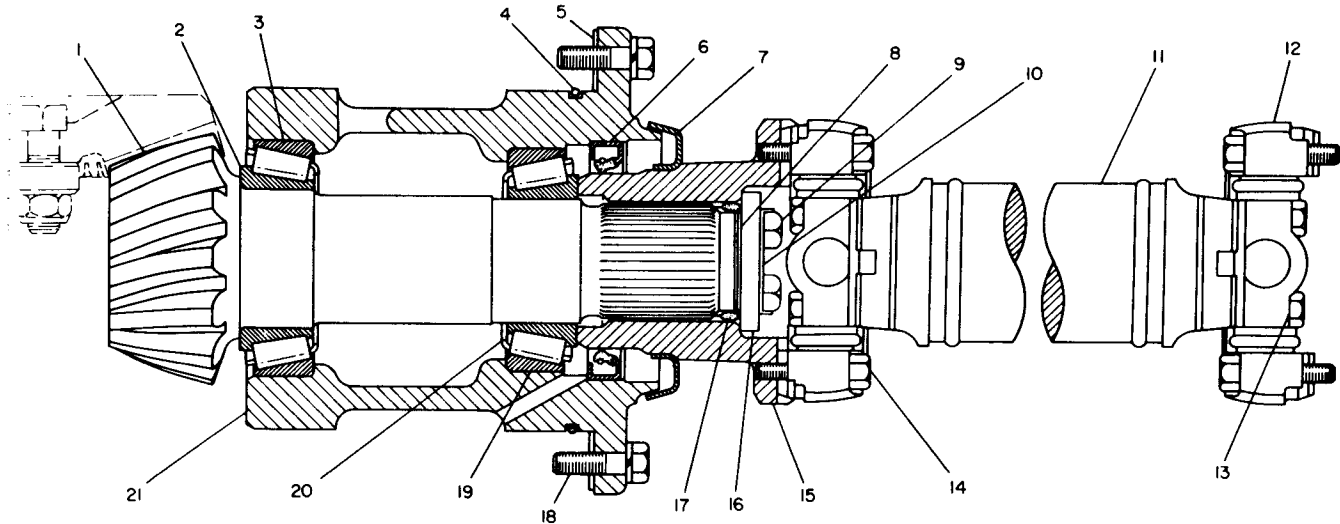

REF NO.	PART NUMBER	DESCRIPTION	QTY
1	6S3117	SHAFT---(bevel pinion-13 teeth)---	1
2	7J8893	CONE-----	1
3	7J8894	CUP-----	1
4	5F3106	SEAL-----	1
5	6S3160	SHIM PACK-----	2
6	9H6079	SEAL-----	1
7	6S4181	GUARD-----	1
8	6S3161	SHIM PACK-----	1
9	6F7030	BOLT-----	2
10	T329	LOCK-----	1

11	6S3256	DRIVE SHAFT ASSEM.-----	1
		(Includes)	
	6S3255	SHAFT ASSEM.-----	1
	6K316	SPIDER & BEARING ASSEM.---	2
		(Each Includes)	
12	7M9878	SEAL-----	4
	2D4867	FITTING-----	1
13	5D4184	BOLT-----	8
14	5D4184	BOLT-----	8
15	6S3158	YOKE-----	1

16	2K1722	WASHER-----	1
17	4F7389	SEAL-----	1
	S1588	BOLT-----	6
18	3B4506	LOCKWASHER-----	6
19	7K8876	CUP-----	1
20	7K8877	CONE-----	1
21	6S3213	HOUSING-----	1

150182

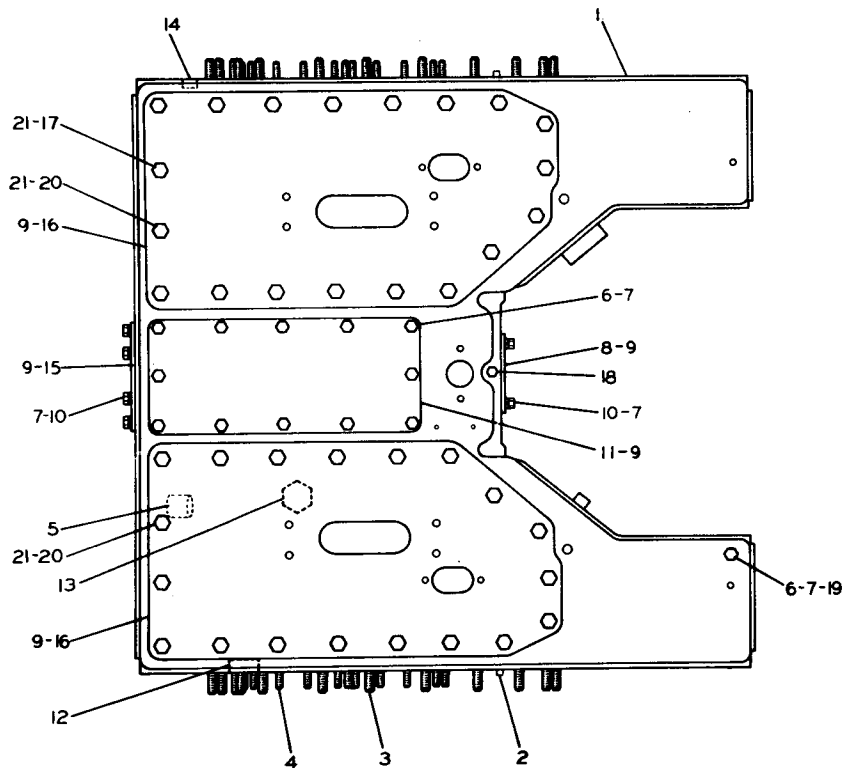

REF. NO.	PART NUMBER	DESCRIPTION	QTY
1	6S3390	CASE ASSEM.-----	1
2	9F2049	DOWEL-----	4
C 3	3D490	STUD-----	24
4	3D2871	STUD-----	24
5	1B6726	BUSHING-----	2
C 6	51594	BOLT-----	13
7	3B4506	LOCKWASHER-----	22
8	6S3265	COVER-----	1
9	7M7260	GASKET SOLUTION-----	
C 10	S509	BOLT-----	10
11	6S3269	COVER-----	1
12	1B5170	PLUG-----	2
13	8M3837	PLUG-----	5
14	6K5551	GASKET-----	5
C 15	6S8224	PLUG-----	6
16	6S3266	COVER-----	1
17	6S3273	COVER-----	2
C 18	S1595	BOLT-----	36
19	5M6214	PLUG-----	1
C 20	4B4278	WASHER-----	1
C 21	S1587	BOLT-----	2
21	3B4508	LOCKWASHER-----	38

C INDICATES CHANGE

217170

6S3527 STEERING CLUTCH CASE GROUP

6S3528 STEERING CLUTCH GROUP

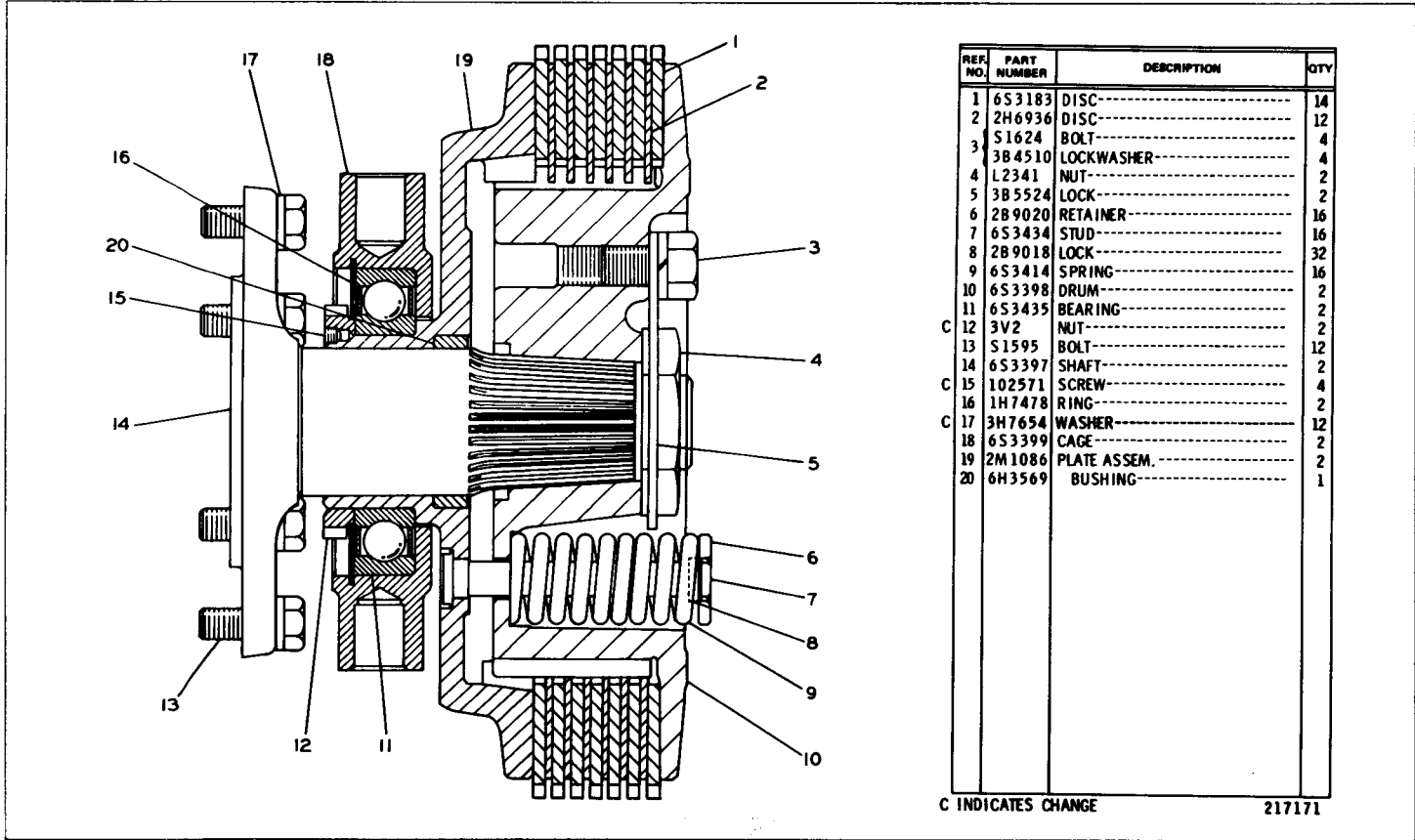

REF. NO.	PART NUMBER	DESCRIPTION	QTY
1	6S3183	DISC-----	14
2	2H6936	DISC-----	12
3	S1624	BOLT-----	4
3	3B4510	LOCKWASHER-----	4
4	L2341	NUT-----	2
5	3B5524	LOCK-----	2
6	2B9020	RETAINER-----	16
7	6S3434	STUD-----	16
8	2B9018	LOCK-----	32
9	6S3414	SPRING-----	16
10	6S3398	DRUM-----	2
11	6S3435	BEARING-----	2
12	3V2	NUT-----	2
13	S1595	BOLT-----	12
14	6S3397	SHAFT-----	2
C 15	102571	SCREW-----	4
16	1H7478	RING-----	2
C 17	3H7654	WASHER-----	12
18	6S3399	CAGE-----	2
19	2M1086	PLATE ASSEM.-----	2
20	6H3569	BUSHING-----	1

C INDICATES CHANGE

217171

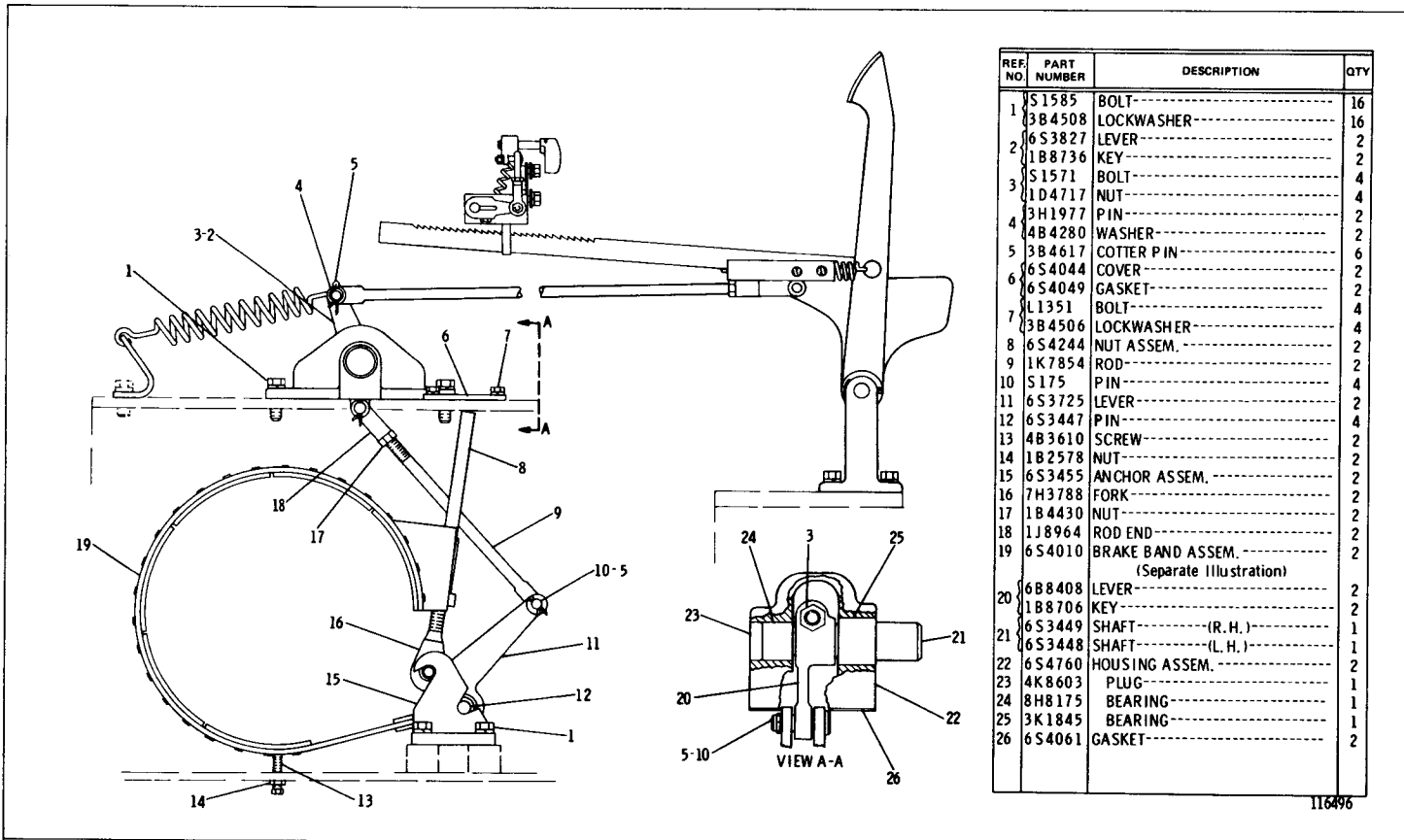

116496

6S3529 STEERING BRAKE GROUP—Stop, Turn and Park—Part 1 of 3  
 Serial No. 79U1 to 79U769 inclusive  
 6S4010 Brake Band Lining parts are shown on Page 48G

6S3529 STEERING BRAKE GROUP—Stop, Turn and Park—Part 2 of 3  
Serial No. 79U1 to 79U769 inclusive

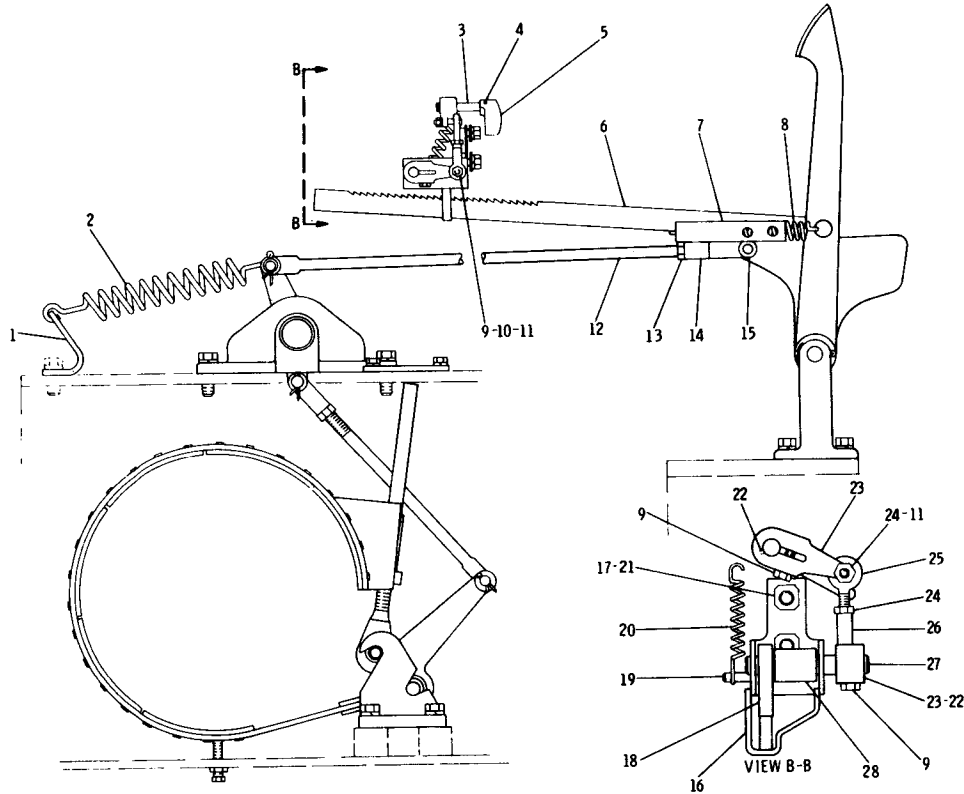

REF. NO.	PART NUMBER	DESCRIPTION	QTY
1	6S6794	PLATE	2
2	6S8277	SPRING	2
3	6S4169	SHAFT	1
4	5B8407	PIN	1
5	4D506	HANDLE	1
6	6S4168	RATCHET	1
7	6S4684	PLATE	2
8	4B6493	SPRING	2
9	S1616	BOLT	3
10	1B4427	NUT	1
11	3B4504	LOCKWASHER	2
12	2H9300	ROD	2
13	1B4430	NUT	2
14	6S6793	ROD END	2
15	S175	PIN	2
16	3B4617	COTTER PIN	2
17	6S4182	BRACKET ASSEM.	1
18	9F2978	NUT	2
19	5K2817	PAWL	1
20	9F7882	PIN	1
21	5K2823	PIN	1
22	1S262	SPRING	1
23	S1594	BOLT	2
24	3B4506	LOCKWASHER	2
25	4B4278	WASHER	2
26	1B8704	KEY	2
27	3D5849	LEVER	2
28	9M1311	NUT	2
1	6S4199	ROD END	1
2	6L7751	ROD END	1
3	6S4198	SHAFT	1
4	6S4183	SPACER	1

C INDICATES CHANGE

119630



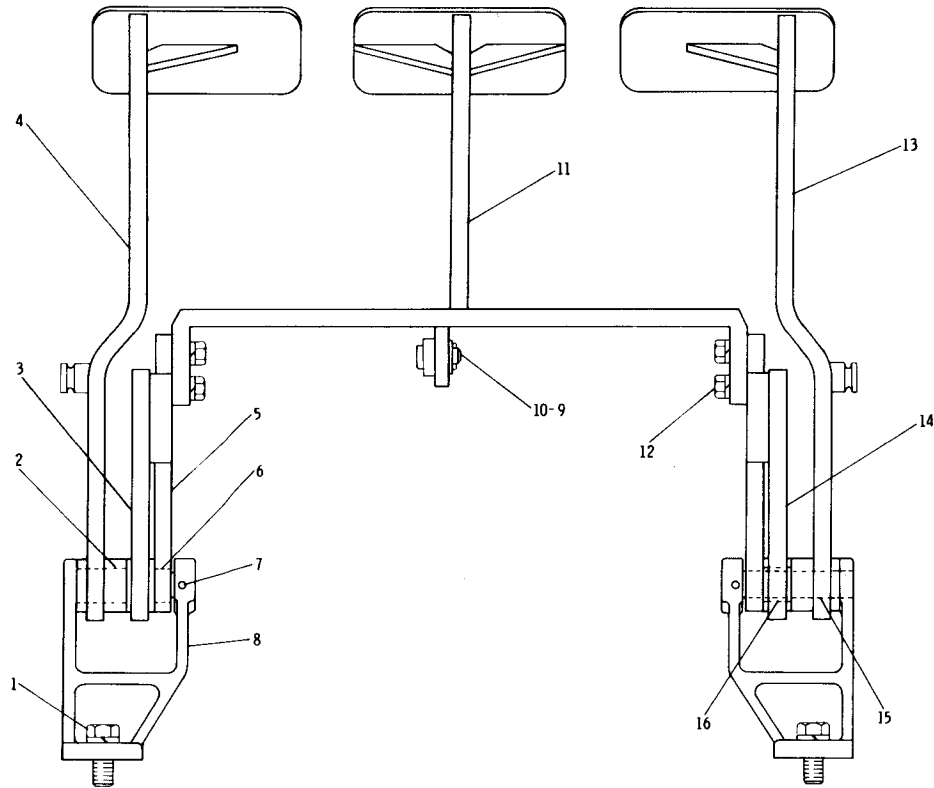

REF NO.	PART NUMBER	DESCRIPTION	QTY
1	7B3235	BOLT-----	4
1	3B4508	LOCKWASHER-----	4
2	6D5974	BEARING-----	4
3	6S3942	LEVER ASSEM.-----	1
4	6S3909	PEDAL ASSEM.-----	1
5	6S3958	LEVER ASSEM.-----	2
6	2K7979	BEARING-----	1
7	3B4631	COTTER PIN-----	2
8	6S6230	BRACKET-----	2
9	3B4617	COTTER PIN-----	1
9	4B4280	WASHER-----	1
10	4H4641	PIN-----	1
11	6S3961	PEDAL ASSEM.-----	1
12	S1594	BOLT-----	4
12	3B4506	LOCKWASHER-----	4
13	6S3929	PEDAL ASSEM.-----	1
14	6S3937	LEVER ASSEM.-----	1
15	6S4776	PIN-----	2
16	6D3787	BEARING-----	2

202067

6S3529 STEERING BRAKE GROUP—Stop, Turn and Park—Part 3 of 3  
Serial No. 79U1 to 79U769 inclusive

6S3529 STEERING BRAKE GROUP—Stop, Turn and Park—Part 1 of 3  
 Serial No. 79U770 to 79U1599 inclusive  
 6S4010 Brake Band Lining parts are shown on Page 48G

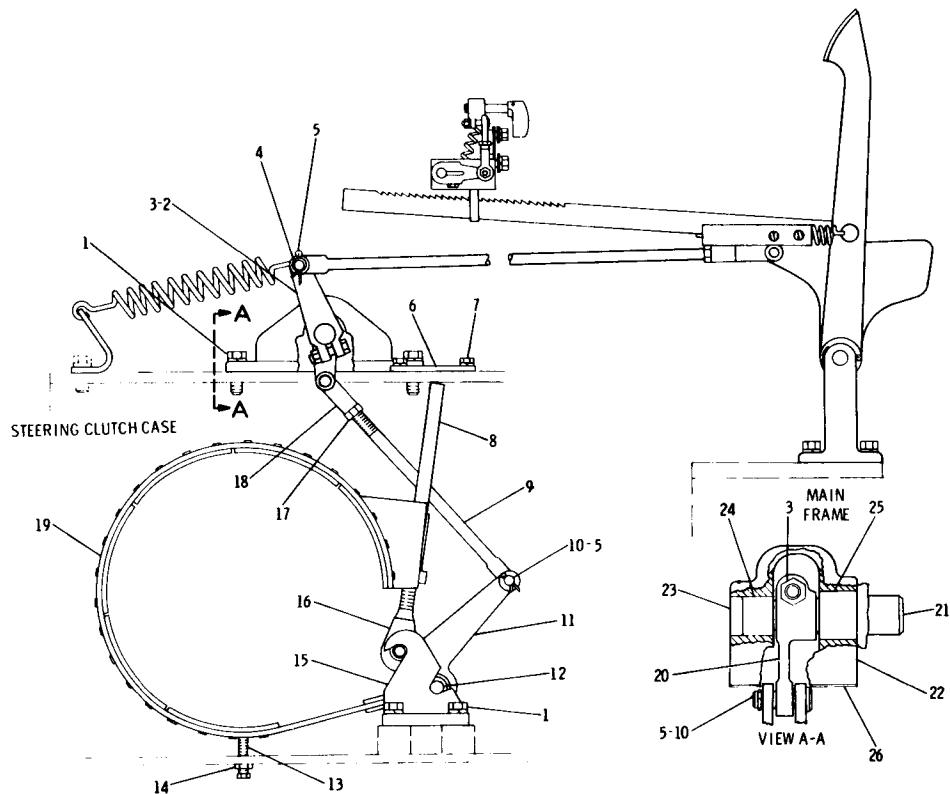

REF NO	PART NUMBER	DESCRIPTION	QTY
1	S 1585	BOLT.....	16
	3B4508	LOCKWASHER.....	16
	6S3827	LEVER.....	2
2	1B8736	KEY.....	2
	S 1571	BOLT.....	4
3	1D4717	NUT.....	4
	3H1977	PIN.....	2
4	4B4280	WASHER.....	2
	3B4617	COTTER PIN.....	6
5	6S4044	COVER.....	2
6	6S4049	GASKET.....	2
7	L1351	BOLT.....	4
	3B4506	LOCKWASHER.....	4
8	6S4244	NUT ASSEM.....	2
C 9	1M1959	ROD.....	2
10	S175	PIN.....	4
11	6S3725	LEVER.....	2
12	6S3447	PIN.....	4
13	4B3610	SCREW.....	2
14	1B2578	NUT.....	2
15	6S3455	ANCHOR ASSEM.....	2
16	7H3788	FORK.....	2
17	1B4430	NUT.....	2
C 18	6F7010	ROD END.....	2
19	6S4010	BRAKE BAND ASSEM..... (Separate Illustration)	2
20	6B8408	LEVER.....	2
	1B8706	KEY.....	2
21	6S3449	SHAFT..... (R. H.)	1
	6S3448	SHAFT..... (L. H.)	1
22	6S4760	HOUSING ASSEM.....	2
23	4K8603	PLUG.....	1
24	8H175	BEARING.....	1
25	3K1845	BEARING.....	1
26	6S4061	GASKET.....	2

C INDICATES CHANGE

153313

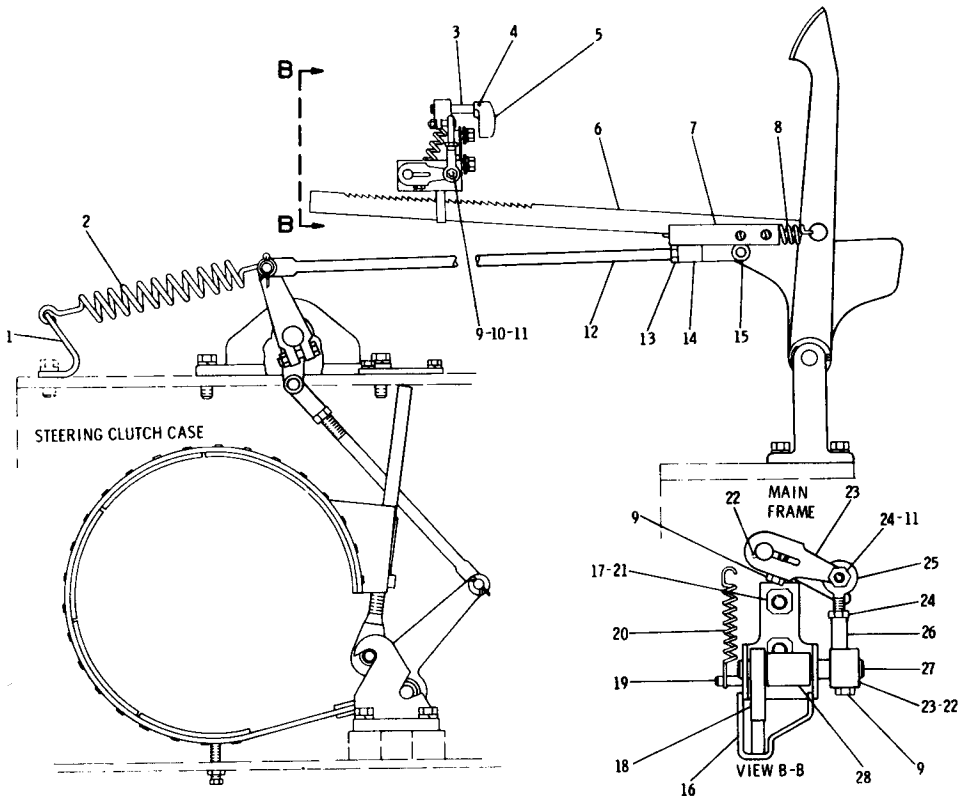

REF. NO.	PART NUMBER	DESCRIPTION	QTY
1	6S6794	PLATE	2
2	6S8277	SPRING	2
3	6S4169	SHAFT	1
C 4	3K4897	PIN	1
5	4D506	HANDLE	1
6	6S4168	RATCHET	1
7	6S4684	PLATE	2
8	4B6493	SPRING	2
9	S1616	BOLT	3
10	1B4427	NUT	1
11	3B4504	LOCKWASHER	2
12	2H9300	ROD	2
13	1B4430	NUT	2
14	6S6793	ROD END	2
15	S175	PIN	2
16	3B4617	COTTER PIN	2
17	6S4182	BRACKET ASSEM.	1
18	9F2978	NUT	2
19	5K2817	PAWL	1
20	9F7882	PIN	1
21	5K2823	PIN	1
C 20	3Y2806	SPRING	1
21	S1594	BOLT	2
22	3B4506	LOCKWASHER	2
23	4B4278	WASHER	2
24	1B8704	KEY	2
25	3D5849	LEVER	2
26	9M1311	NUT	2
27	6S4199	ROD END	1
28	6L7751	ROD END	1
29	6S4198	SHAFT	1
30	6S4183	SPACER	1

C INDICATES CHANGE

153314

6S3529 STEERING BRAKE GROUP—Stop, Turn and Park—Part 2 of 3  
Serial No. 79U770 to 79U1599 inclusive

6S3529 STEERING BRAKE GROUP—Stop, Turn and Park—Part 3 of 3  
 Serial No. 79U770 to 79U1599 inclusive

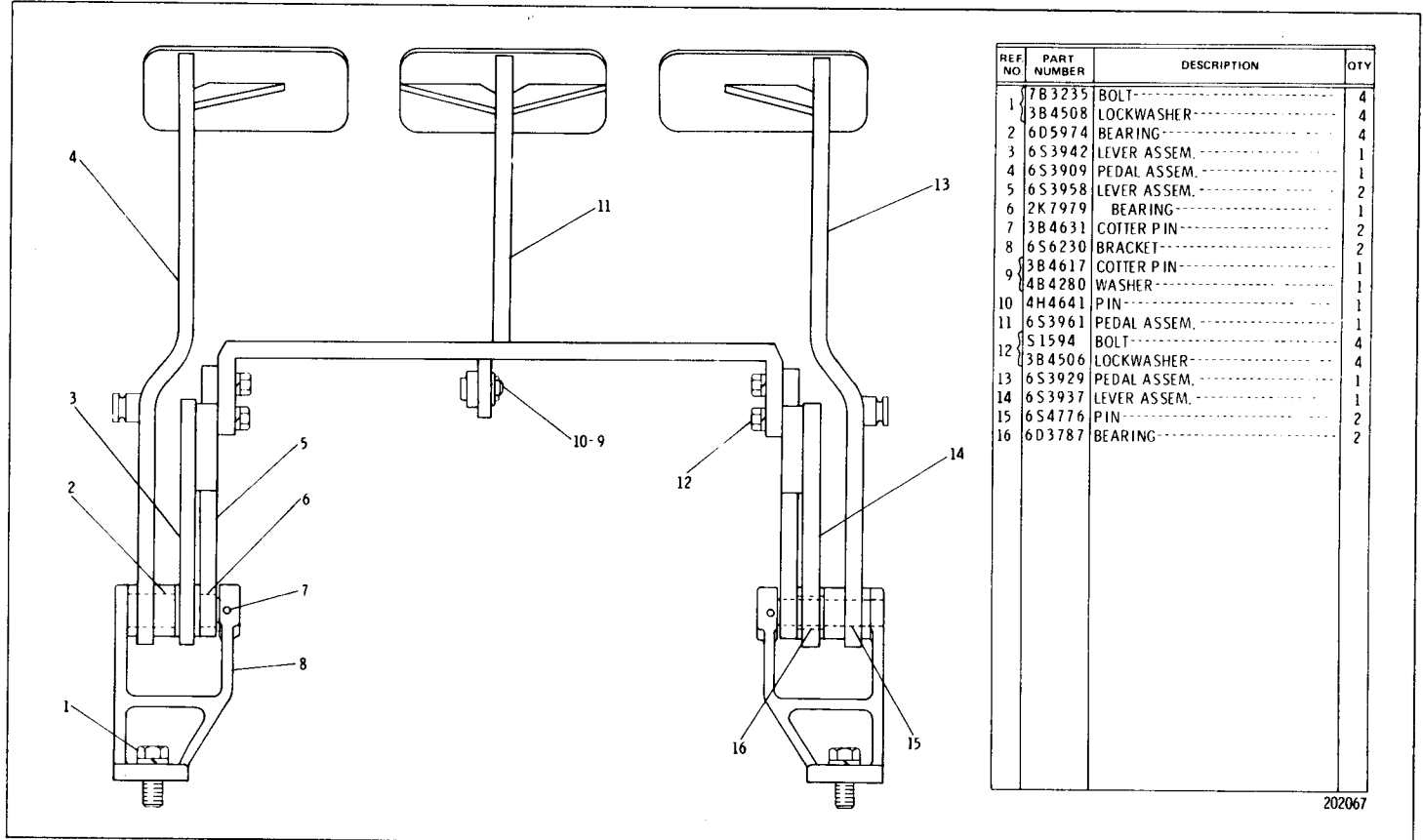

REF NO	PART NUMBER	DESCRIPTION	QTY
1	7B3235	BOLT	4
1	3B4508	LOCKWASHER	4
2	6D5974	BEARING	4
3	6S3942	LEVER ASSEM.	1
4	6S3909	PEDAL ASSEM.	1
5	6S3958	LEVER ASSEM.	2
6	2K7979	BEARING	1
7	3B4631	COTTER PIN	2
8	6S6230	BRACKET	2
9	3B4617	COTTER PIN	1
9	4B4280	WASHER	1
10	4H4641	PIN	1
11	6S3961	PEDAL ASSEM.	1
12	S1594	BOLT	4
12	3B4506	LOCKWASHER	4
13	6S3929	PEDAL ASSEM.	1
14	6S3937	LEVER ASSEM.	1
15	6S4776	PIN	2
16	6D3787	BEARING	2

202067

STEERING CLUTCHES AND BRAKES

48C

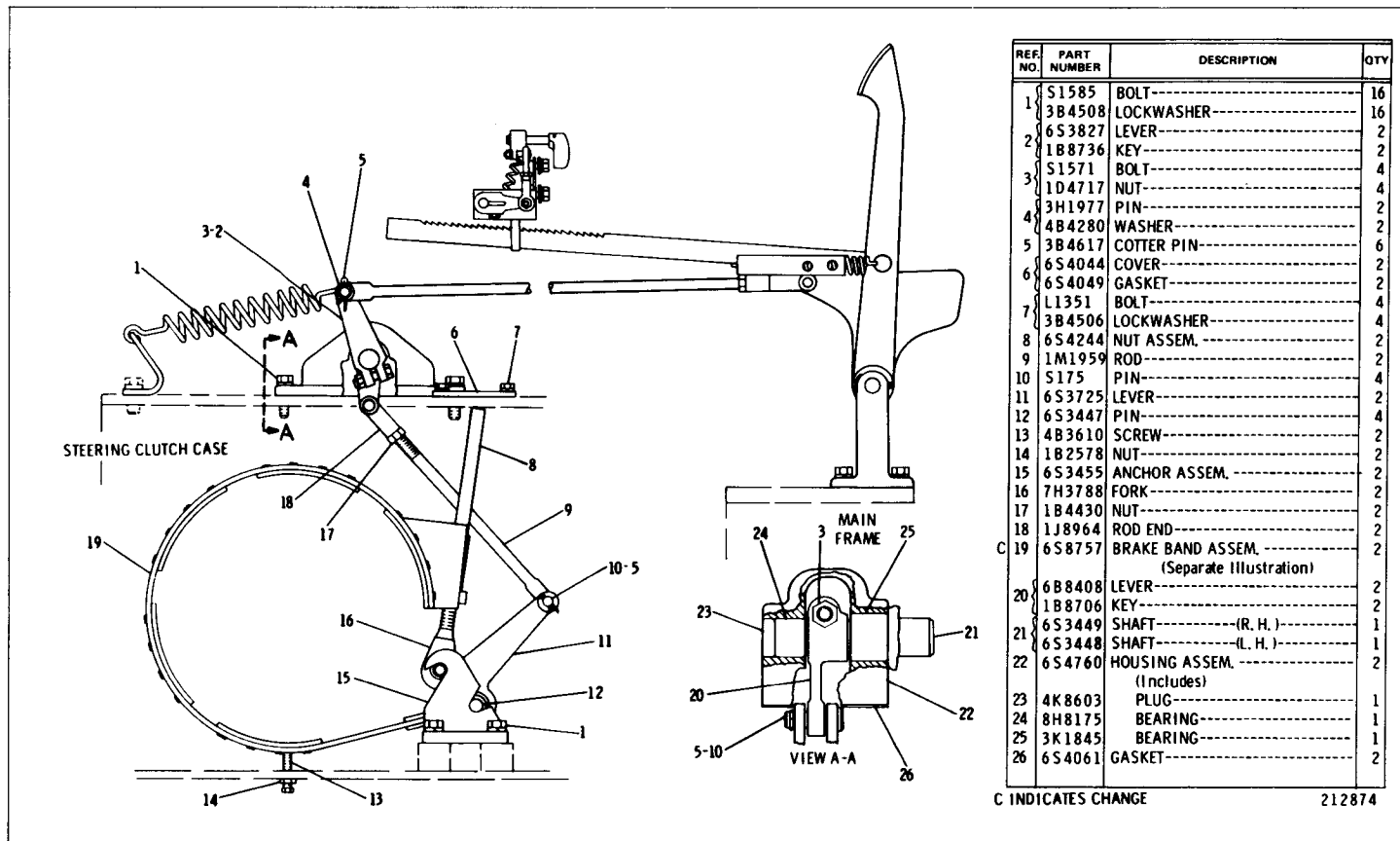

6S3529 STEERING BRAKE GROUP—Stop, Turn and Park—Part 1 of 3  
 Serial No. 79U1600 to 79U2758 inclusive  
 6S8757 Brake Band Lining parts are shown on Page 48D

6S3529 STEERING BRAKE GROUP—Stop, Turn and Park—Part 2 of 3  
 Serial No. 79U1600 to 79U2758 inclusive

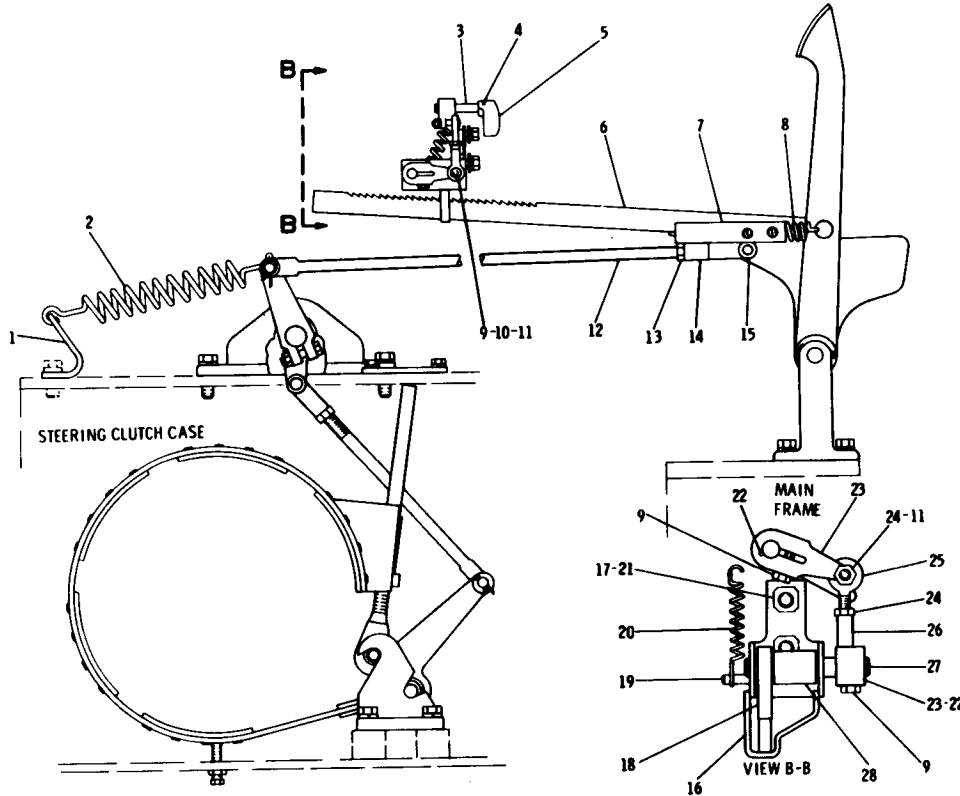

REF. NO.	PART NUMBER	DESCRIPTION	QTY
1	6S6794	PLATE-----	2
2	6S8277	SPRING-----	2
3	6S4169	SHAFT-----	1
4	3K4897	PIN-----	1
5	4D506	HANDLE-----	1
6	6S4168	RATCHET-----	1
7	6S4684	PLATE-----	2
8	4B6493	SPRING-----	2
9	S1616	BOLT-----	3
10	1B4427	NUT-----	1
11	3B4504	LOCKWASHER-----	2
12	2H9300	ROD-----	2
13	1B4430	NUT-----	2
14	6S6793	ROD END-----	2
15	S175	PIN-----	2
15	3B4617	COTTER PIN-----	2
16	6S4182	BRACKET ASSEM. (Includes)	1
17	9F2978	NUT-----	2
18	5K2817	PAWL-----	1
18	9F7882	PIN-----	1
19	5K2823	PIN-----	1
20	3Y2806	SPRING-----	1
21	S1594	BOLT-----	2
21	3B4506	LOCKWASHER-----	2
21	4B4278	WASHER-----	2
22	1B8704	KEY-----	2
23	3D5849	LEVER-----	2
24	9M1311	NUT-----	2
25	6S4199	ROD END-----	1
26	6L7751	ROD END-----	1
27	6S4198	SHAFT-----	1
28	6S4183	SPACER-----	1

212875

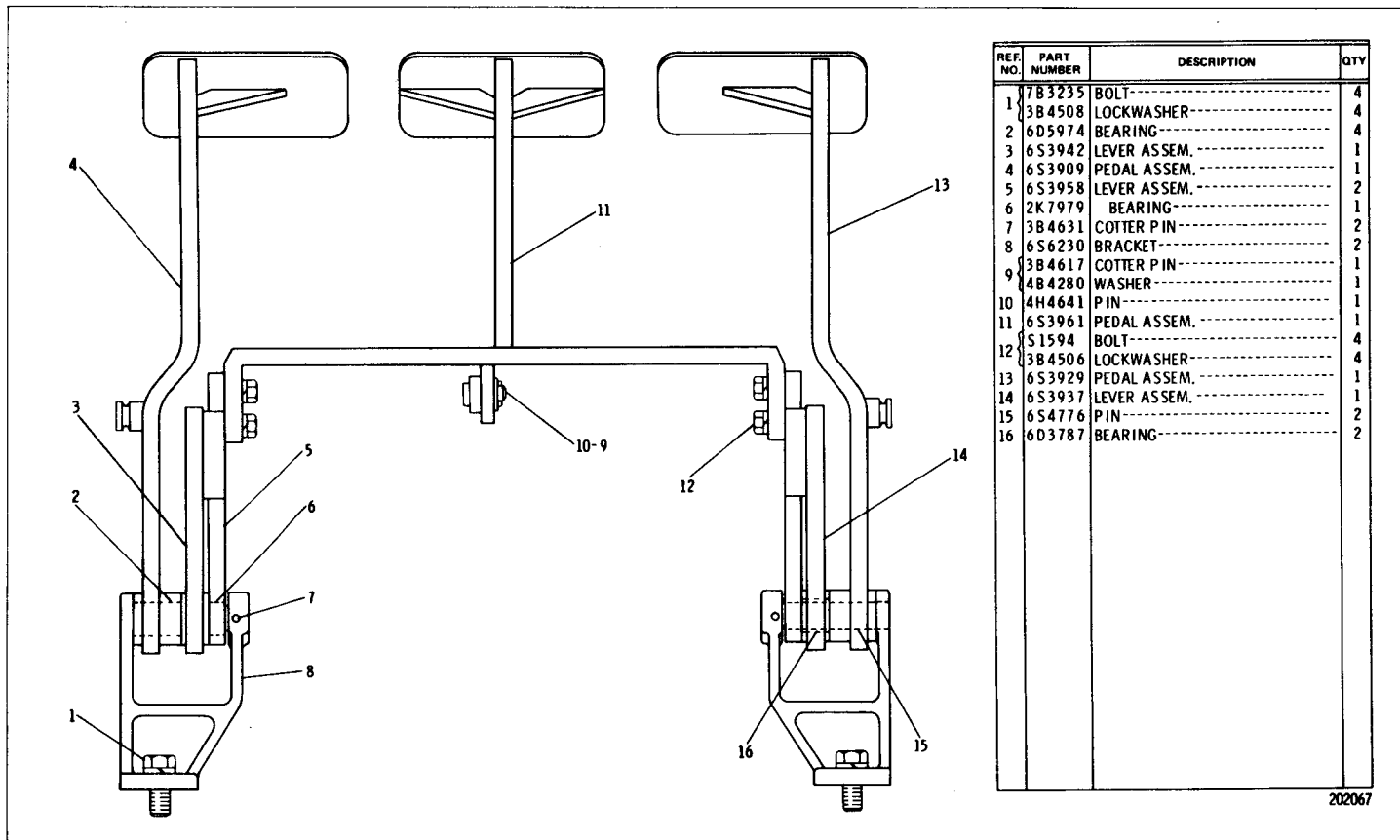

REF NO.	PART NUMBER	DESCRIPTION	QTY
1	7B3235	BOLT-----	4
	3B4508	LOCKWASHER-----	4
2	6D5974	BEARING-----	4
3	6S3942	LEVER ASSEM.-----	1
4	6S3909	PEDAL ASSEM.-----	1
5	6S3958	LEVER ASSEM.-----	2
6	2K7979	BEARING-----	1
7	3B4631	COTTER PIN-----	2
8	6S6230	BRACKET-----	2
9	3B4617	COTTER PIN-----	1
	4B4280	WASHER-----	1
10	4H4641	PIN-----	1
11	6S3961	PEDAL ASSEM.-----	1
12	S1594	BOLT-----	4
	3B4506	LOCKWASHER-----	4
13	6S3929	PEDAL ASSEM.-----	1
14	6S3937	LEVER ASSEM.-----	1
15	6S4776	PIN-----	2
16	6D3787	BEARING-----	2

202067

6S3529 STEERING BRAKE GROUP—Stop, Turn and Park—Part 3 of 3  
Serial No. 79U1600 to 79U2758 inclusive

6S3529 STEERING BRAKE GROUP—Stop, Turn and Park—Part 1 of 3  
 Serial No. 79U2759 to 79U3228 inclusive  
 6S8757 Brake Band Lining parts are shown on Page 48G

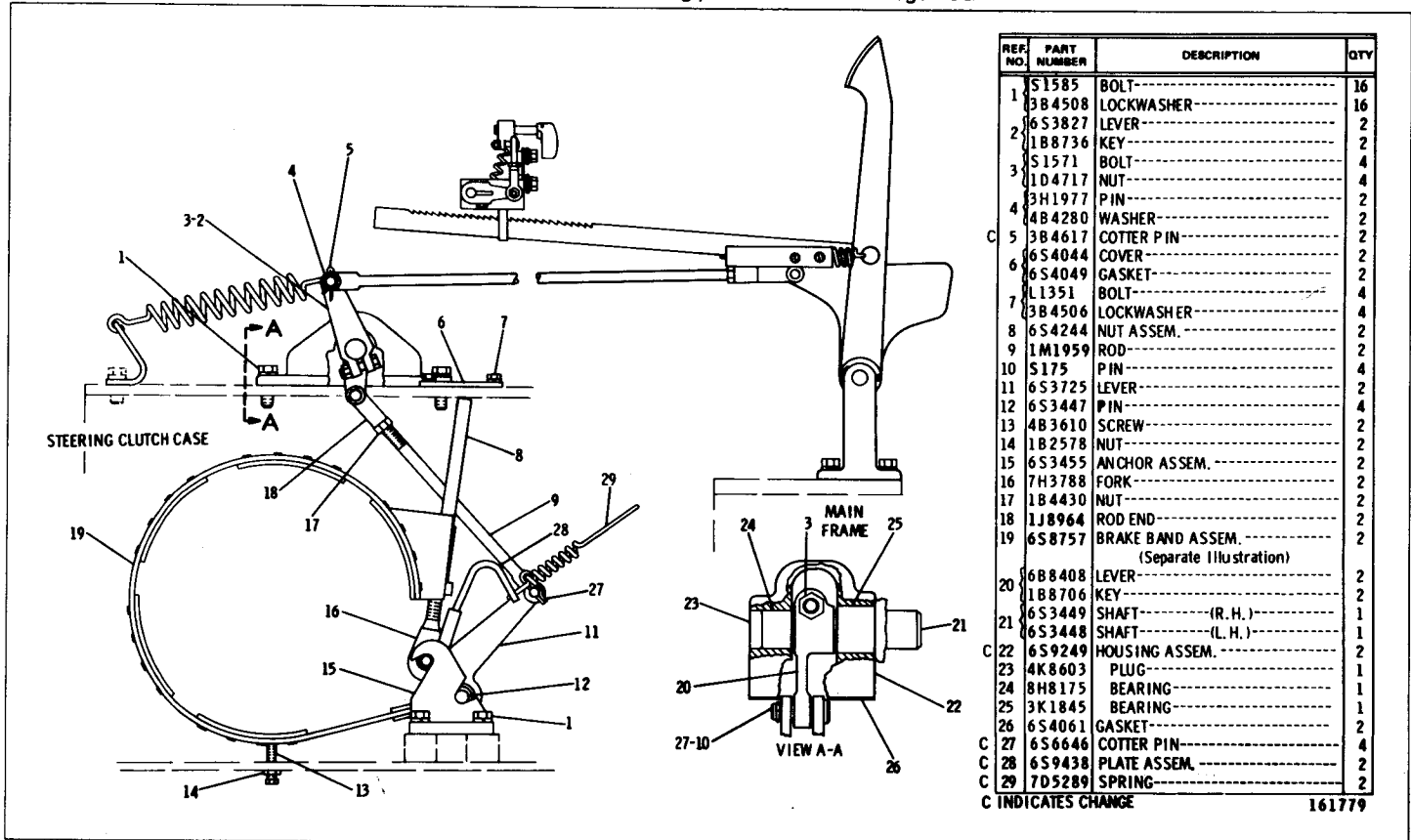

REF. NO.	PART NUMBER	DESCRIPTION	QTY
1	S1585	BOLT	16
	3B4508	LOCKWASHER	16
2	6S3827	LEVER	2
	1B8736	KEY	2
3	S1571	BOLT	4
	1D4717	NUT	4
	3H1977	PIN	2
4	4B4280	WASHER	2
C 5	3B4617	COTTER PIN	2
	6S4044	COVER	2
6	6S4049	GASKET	2
	1L1351	BOLT	4
7	3B4506	LOCKWASHER	4
8	6S4244	NUT ASSEM.	2
9	1M1959	ROD	2
10	S175	PIN	4
11	6S3725	LEVER	2
12	6S3447	PIN	4
13	4B3610	SCREW	2
14	1B2578	NUT	2
15	6S3455	ANCHOR ASSEM.	2
16	7H3788	FORK	2
17	1B4430	NUT	2
18	1J8964	ROD END	2
19	6S8757	BRAKE BAND ASSEM.	2
		(Separate Illustration)	
20	6B8408	LEVER	2
	1B8706	KEY	2
21	6S3449	SHAFT (R. H.)	1
	6S3448	SHAFT (L. H.)	1
C 22	6S9249	HOUSING ASSEM.	2
23	4K8603	PLUG	1
24	8H8175	BEARING	1
25	3K1845	BEARING	1
26	6S4061	GASKET	2
C 27	6S6646	COTTER PIN	4
C 28	6S9438	PLATE ASSEM.	2
C 29	7D5289	SPRING	2

C INDICATES CHANGE

161779

STEERING CLUTCHES AND BRAKES

48F-1



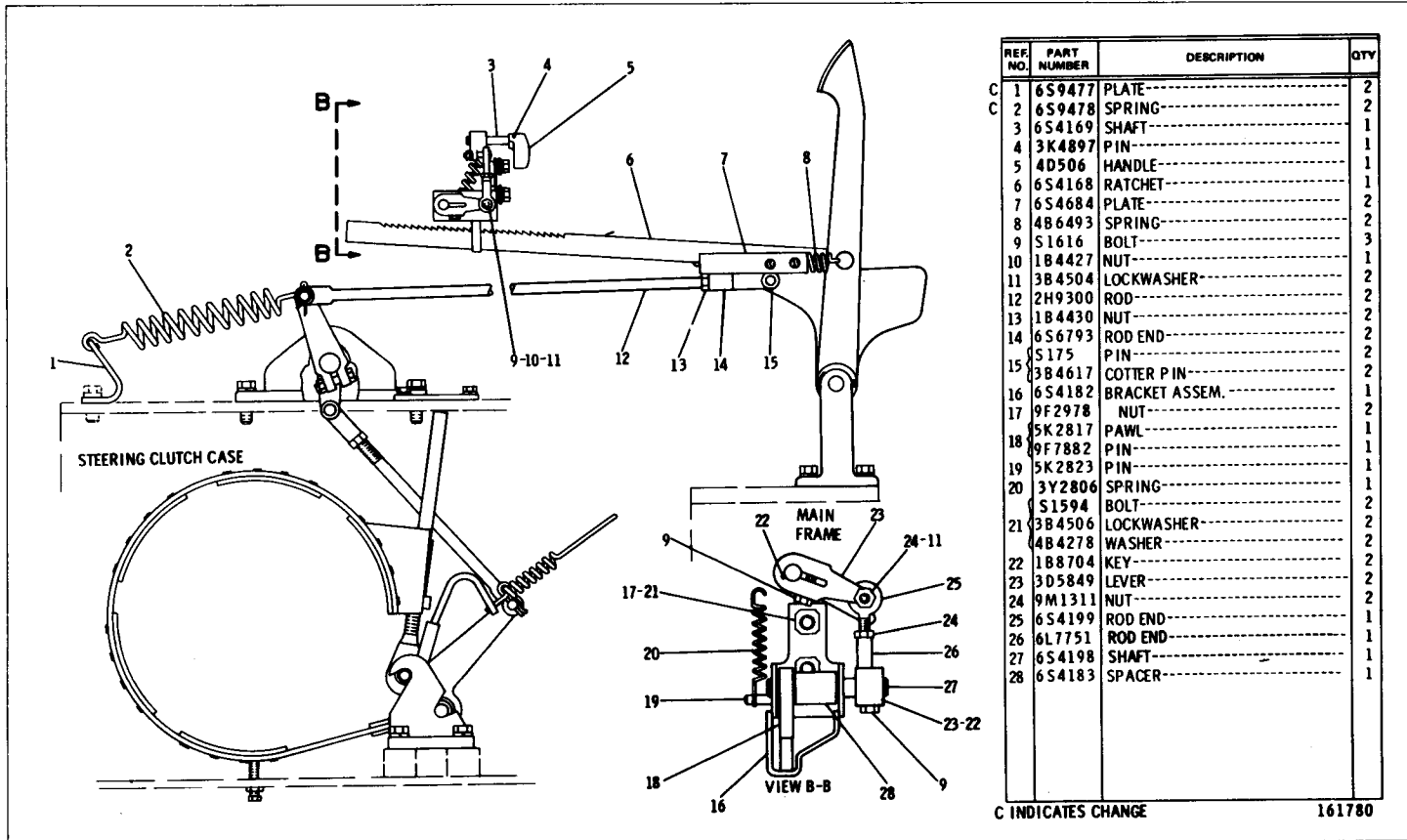

6S3529 STEERING BRAKE GROUP—Stop, Turn and Park—Part 2 of 3  
Serial No. 79U2759 to 79U3228 inclusive

6S3529 STEERING BRAKE GROUP—Stop, Turn and Park—Part 3 of 3  
 Serial No. 79U2759 to 79U3228 inclusive

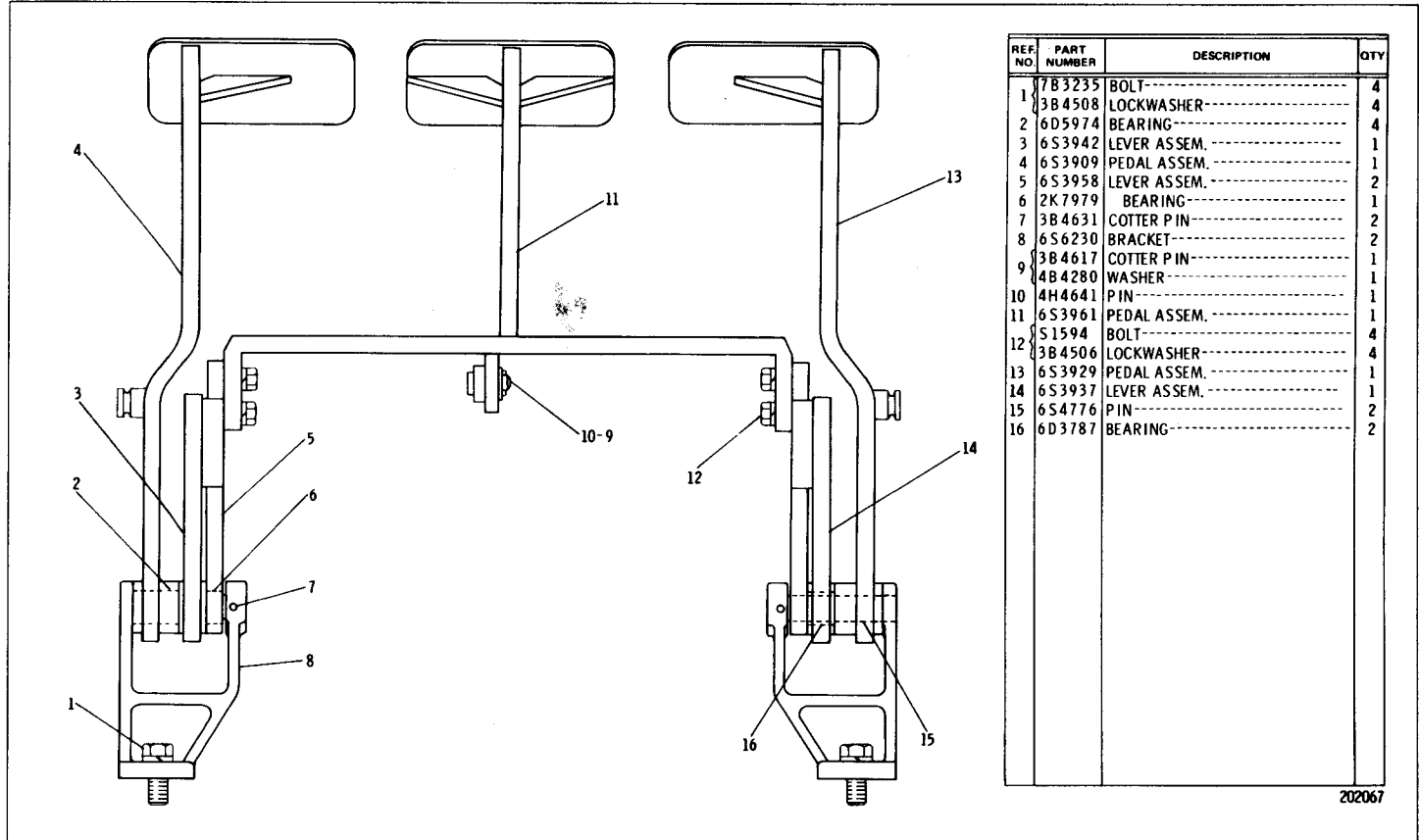

REF. NO.	PART NUMBER	DESCRIPTION	QTY
1	7B3235	BOLT-----	4
1	3B4508	LOCKWASHER-----	4
2	6D5974	BEARING-----	4
3	6S3942	LEVER ASSEM.-----	1
4	6S3909	PEDAL ASSEM.-----	1
5	6S3958	LEVER ASSEM.-----	2
6	2K7979	BEARING-----	1
7	3B4631	COTTER PIN-----	2
8	6S6230	BRACKET-----	2
9	3B4617	COTTER PIN-----	1
9	4B4280	WASHER-----	1
10	4H4641	PIN-----	1
11	6S3961	PEDAL ASSEM.-----	1
12	51594	BOLT-----	4
12	3B4506	LOCKWASHER-----	4
13	6S3929	PEDAL ASSEM.-----	1
14	6S3937	LEVER ASSEM.-----	1
15	6S4776	PIN-----	2
16	6D3787	BEARING-----	2

202067

REF. NO.	PART NUMBER	DESCRIPTION	QTY
C 1	S1585	BOLT-----38.10 mm(1.50 in.) long	8
2	6S3827	LEVER-----	2
	1B8736	KEY-----	2
3	S1571	BOLT-----	4
	1D4717	NUT-----	4

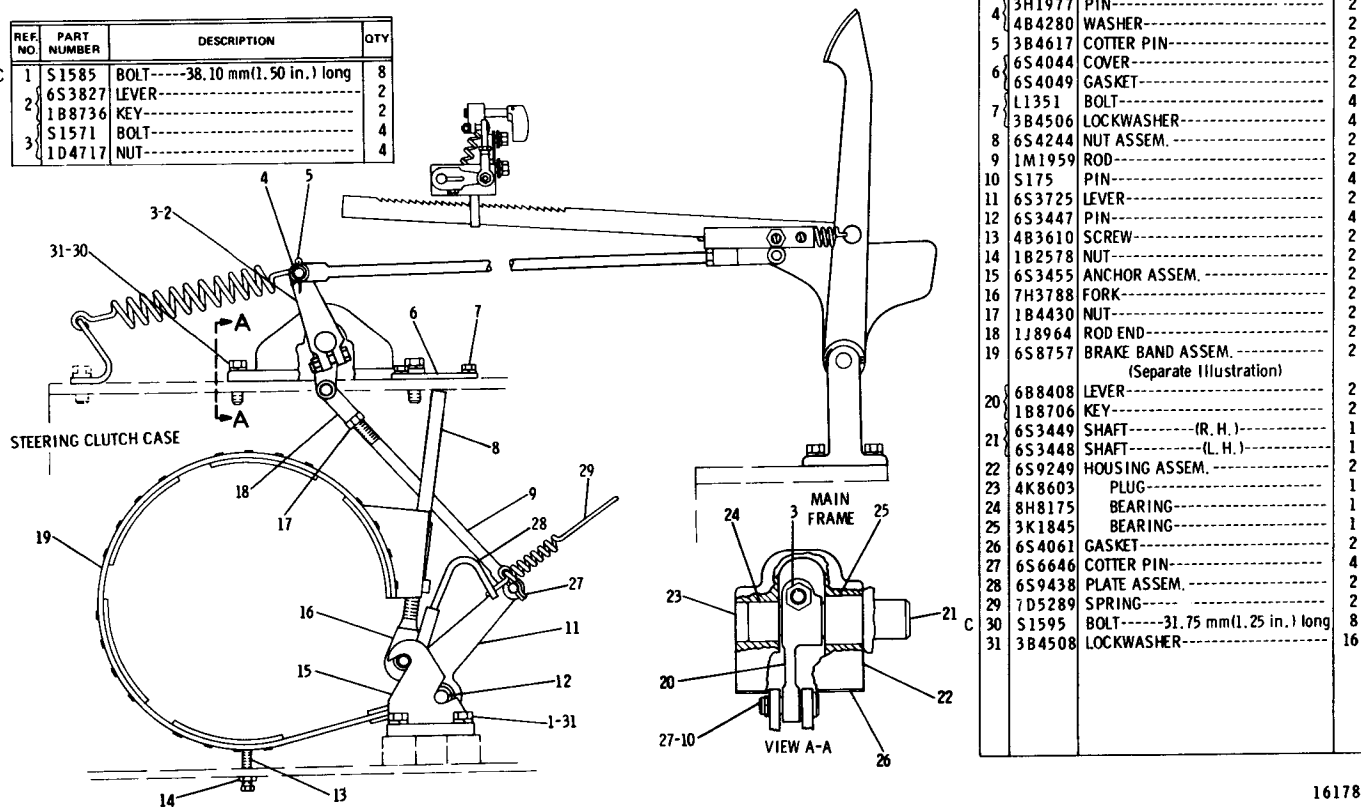

4	3H1977	PIN-----	2
	4B4280	WASHER-----	2
5	3B4617	COTTER PIN-----	2
	6S4044	COVER-----	2
6	6S4049	GASKET-----	2
	L1351	BOLT-----	4
7	3B4506	LOCKWASHER-----	4
	6S4244	NUT ASSEM.-----	2
9	1M1959	ROD-----	2
10	S175	PIN-----	4
11	6S3725	LEVER-----	2
12	6S3447	PIN-----	4
13	4B3610	SCREW-----	2
14	1B2578	NUT-----	2
15	6S3455	ANCHOR ASSEM.-----	2
16	7H3788	FORK-----	2
17	1B4430	NUT-----	2
18	1J8964	ROD END-----	2
19	6S8757	BRAKE BAND ASSEM.-----	2
		(Separate Illustration)	
20	6B8408	LEVER-----	2
	1B8706	KEY-----	2
21	6S3449	SHAFT----- (R. H.)-----	1
	6S3448	SHAFT----- (L. H.)-----	1
22	6S9249	HOUSING ASSEM.-----	2
23	4K8603	PLUG-----	1
24	8H8175	BEARING-----	1
25	3K1845	BEARING-----	1
26	6S4061	GASKET-----	2
27	6S6646	COTTER PIN-----	4
28	6S9438	PLATE ASSEM.-----	2
29	7D5289	SPRING-----	2
30	S1595	BOLT-----31.75 mm(1.25 in.) long	8
31	3B4508	LOCKWASHER-----	16

6S3529 STEERING BRAKE GROUP—Stop, Turn and Park—Part 1 of 3  
 Serial No. 79U3229 to 79U4384 inclusive  
 6S8757 Brake Band Lining parts are shown on Page 48G

6S3529 STEERING BRAKE GROUP—Stop, Turn and Park—Part 2 of 3  
 Serial No. 79U3229 to 79U4384 inclusive

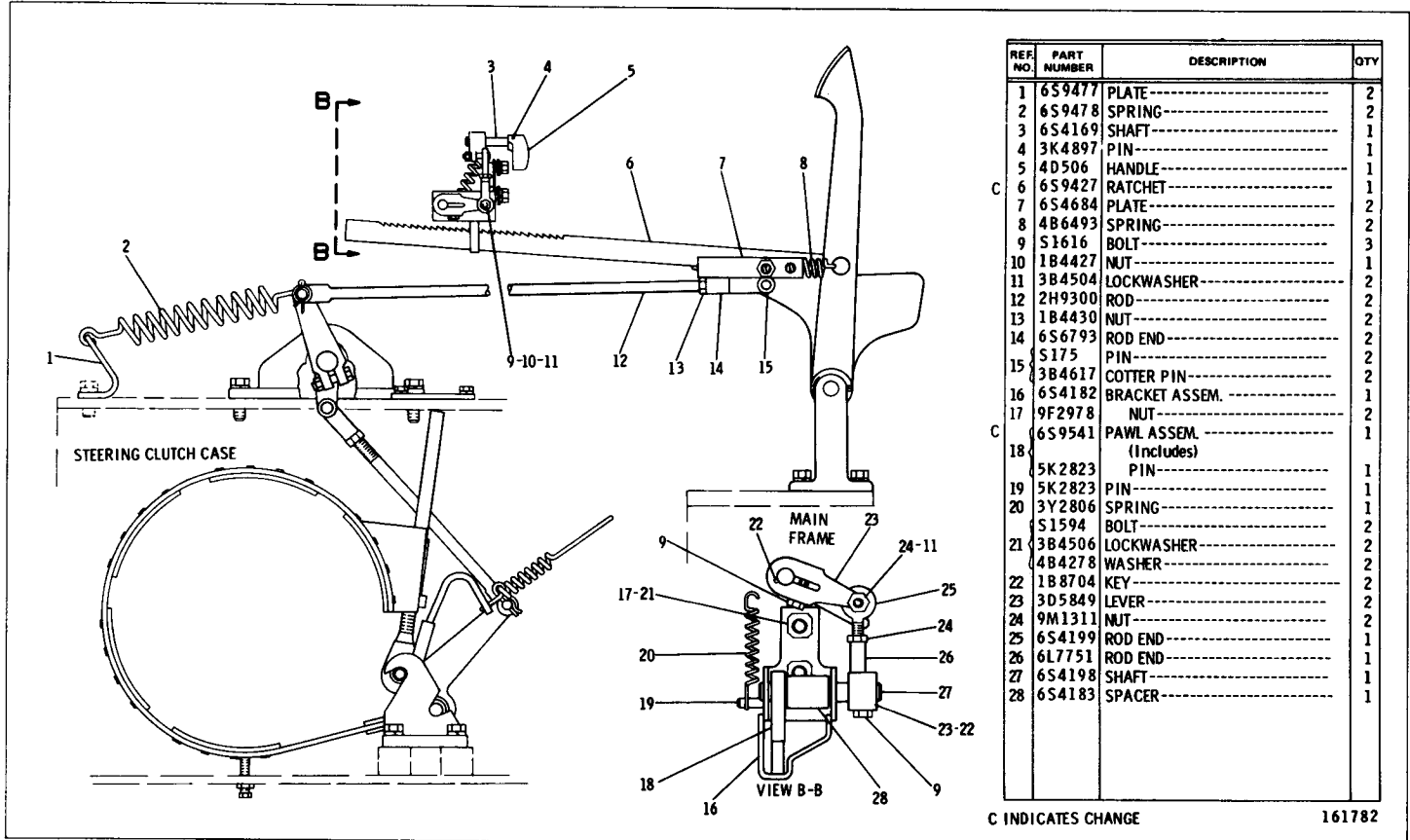

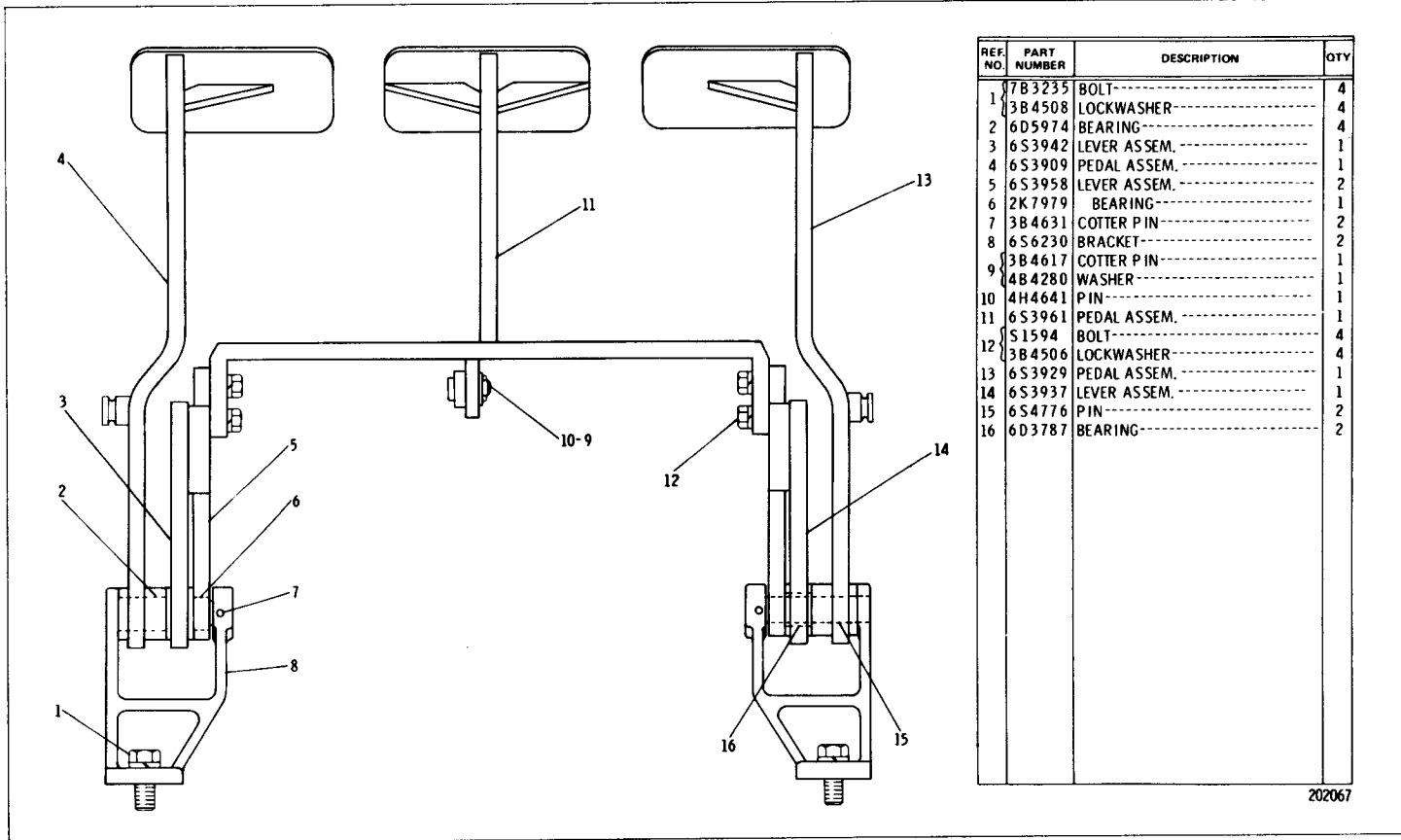

202067

6S3529 STEERING BRAKE GROUP—Stop, Turn and Park—Part 3 of 3  
 Serial No. 79U3229 to 79U4384 inclusive

6S3529 STEERING BRAKE GROUP—Stop, Turn and Park—Part 1 of 3  
 Serial No. 79U4385 to 79U4505 inclusive  
 6S8757 Brake Band Lining parts are shown on Page 48G

REF. NO.	PART NUMBER	DESCRIPTION	QTY
1	S1585	BOLT-----38.10 mm(1.50 in.) long	8
2	6S3827	LEVER-----	2
	1B8736	KEY-----	2
3	S1571	BOLT-----	4
	1D4717	NUT-----	4

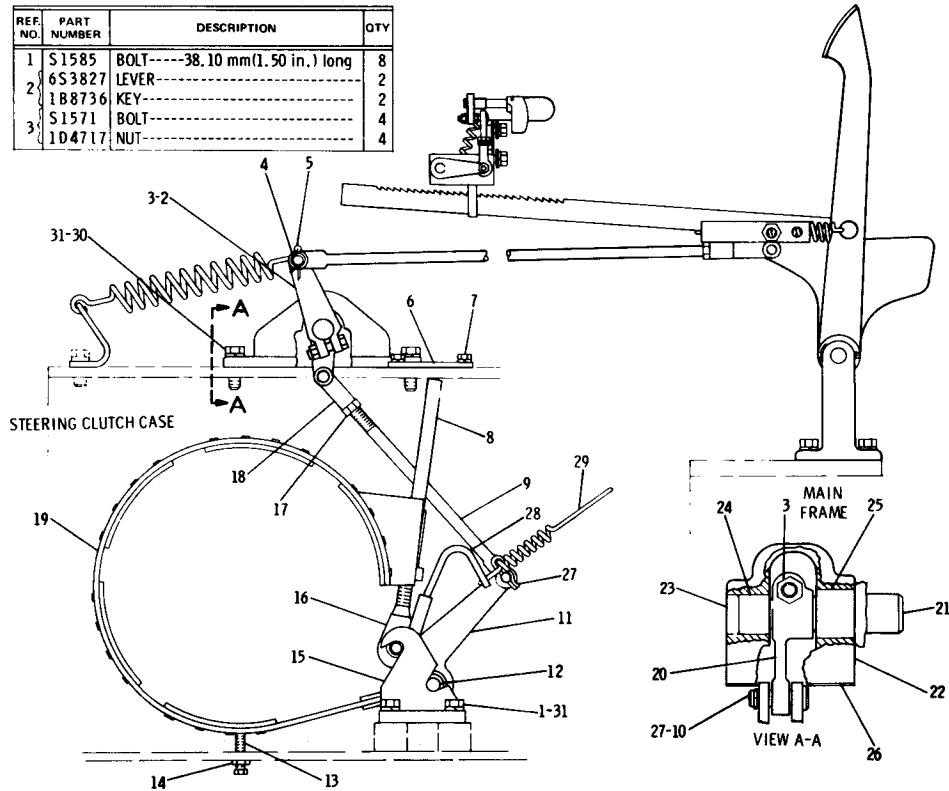

4	3H1977	PIN-----	2
	4B4280	WASHER-----	2
5	3B4617	COTTER PIN-----	2
	6S4044	COVER-----	2
6	6S4049	GASKET-----	2
	L1351	BOLT-----	4
7	3B4506	LOCKWASHER-----	4
8	6S4244	NUT ASSEM.-----	2
9	1M1959	ROD-----	2
10	S175	PIN-----	4
11	6S3725	LEVER-----	2
12	6S3447	PIN-----	4
13	4B3610	SCREW-----	2
14	1B2578	NUT-----	2
15	6S3455	ANCHOR ASSEM.-----	2
16	7H3788	FORK-----	2
17	1B4430	NUT-----	2
18	1J8964	ROD END-----	2
19	6S8757	BRAKE BAND ASSEM.-----	2
		(Separate Illustration)	
20	6B8408	LEVER-----	2
	1B8706	KEY-----	2
21	6S3449	SHAFT----- (R. H.)	1
	6S3448	SHAFT----- (L. H.)	1
22	6S9249	HOUSING ASSEM.-----	2
23	4K8603	PLUG-----	1
24	8H8175	BEARING-----	1
25	3K1845	BEARING-----	1
26	6S4061	GASKET-----	2
27	6S6646	COTTER PIN-----	4
28	6S9438	PLATE ASSEM.-----	2
29	7D5289	SPRING-----	2
30	S1595	BOLT-----31.75 mm(1.25 in.) long	8
31	3B4508	LOCKWASHER-----	16

217140

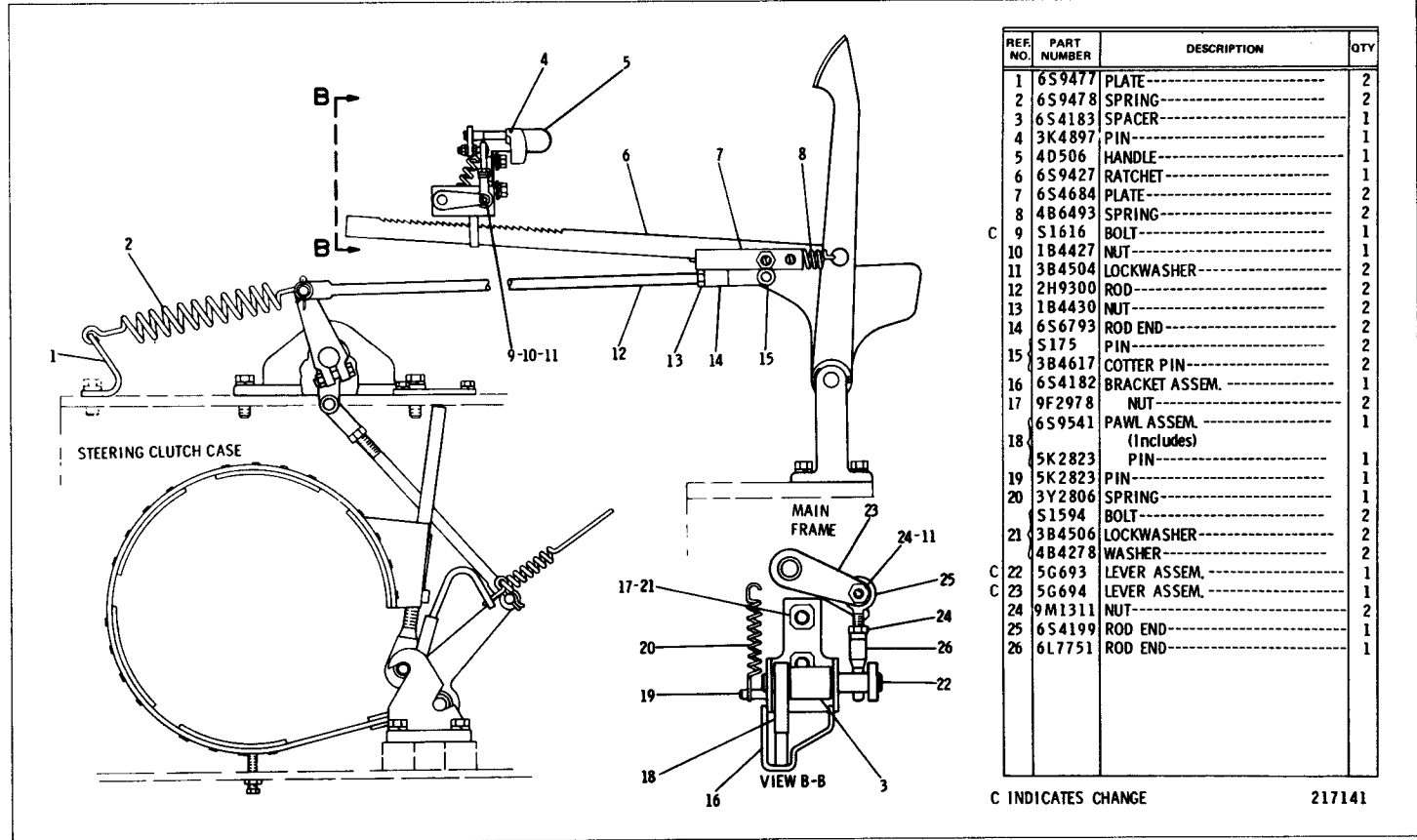

6S3529 STEERING BRAKE GROUP—Stop, Turn and Park—Part 2 of 3  
 Serial No. 79U4385 to 79U4505 inclusive

6S3529 STEERING BRAKE GROUP—Stop, Turn and Park—Part 3 of 3  
 Serial No. 79U4385 to 79U4505 inclusive

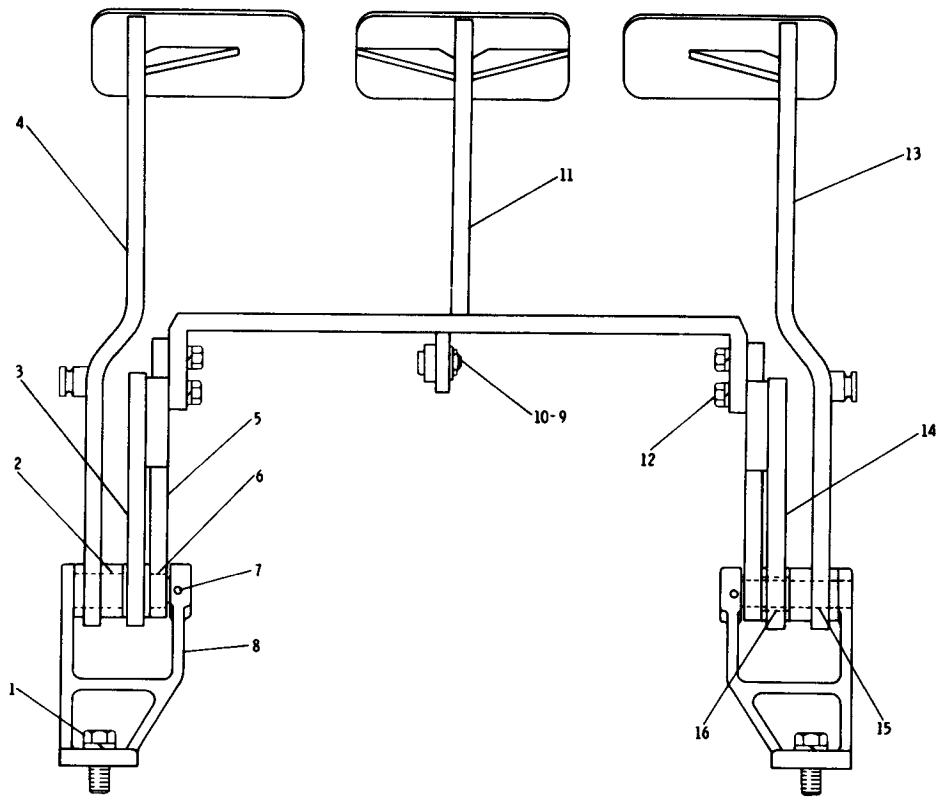

REF NO.	PART NUMBER	DESCRIPTION	QTY
1	7B3235	BOLT-----	4
2	3B4508	LOCKWASHER-----	4
3	6D5974	BEARING-----	4
4	6S3942	LEVER ASSEM.-----	1
5	6S3909	PEDAL ASSEM.-----	1
6	6S3958	LEVER ASSEM.-----	2
7	2K7979	BEARING-----	1
8	3B4631	COTTER PIN-----	2
9	6S6230	BRACKET-----	2
10	3B4617	COTTER PIN-----	1
11	4B4280	WASHER-----	1
12	4H4641	PIN-----	1
13	6S3961	PEDAL ASSEM.-----	1
14	S1594	BOLT-----	4
15	3B4506	LOCKWASHER-----	4
16	6S3929	PEDAL ASSEM.-----	1
	6S3937	LEVER ASSEM.-----	1
	6S4776	PIN-----	2
	6D3787	BEARING-----	2

202067



REF. NO.	PART NUMBER	DESCRIPTION	QTY
1	S1585	BOLT-----38.10 mm(1.50 in.) long	8
2	6S3827	LEVER-----	2
	1B8736	KEY-----	2
3	S1571	BOLT-----	4
	1D4717	NUT-----	4

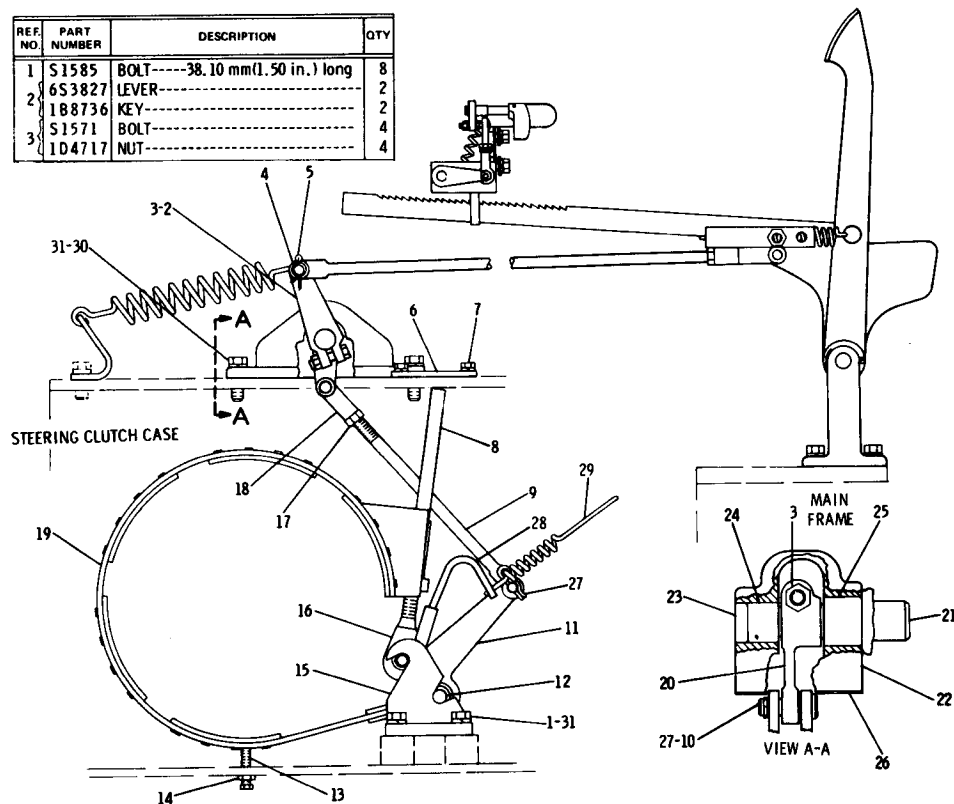

4	3H1977	PIN-----	2
	4B4280	WASHER-----	2
5	3B4617	COTTER PIN-----	2
	6S4044	COVER-----	2
6	6S4049	GASKET-----	2
	L1351	BOLT-----	4
7	3B4506	LOCKWASHER-----	4
8	6S4244	NUT ASSEM.-----	2
9	1M1959	ROD-----	2
10	S175	PIN-----	4
11	6S3725	LEVER-----	2
12	6S3447	PIN-----	4
13	4B3610	SCREW-----	2
14	1B2578	NUT-----	2
15	6S3455	ANCHOR ASSEM.-----	2
16	7H3788	FORK-----	2
17	1B4430	NUT-----	2
18	1J8964	ROD END-----	2
C 19	5G1073	BRAKE BAND ASSEM. (Separate Illustration)	2
	6B8408	LEVER-----	2
20	1B8706	KEY-----	2
	6S3449	SHAFT----- (R. H.)	1
21	6S3448	SHAFT----- (L. H.)	1
22	6S9249	HOUSING ASSEM.-----	2
23	4K8603	PLUG-----	1
24	8H8175	BEARING-----	1
25	3K1845	BEARING-----	1
26	6S4061	GASKET-----	2
27	6S6646	COTTER PIN-----	4
28	6S9438	PLATE ASSEM.-----	2
29	7D5289	SPRING-----	2
30	S1595	BOLT-----31.75 mm(1.25 in.) long	8
31	3B4508	LOCKWASHER-----	16

C INDICATES CHANGE

217142

6S3529 STEERING BRAKE GROUP—Stop, Turn and Park—Part 1 of 3  
 Serial No. 79U4506 to 79U4553 inclusive  
 5G1073 Brake Band Lining parts are shown on Page 48H

6S3529 STEERING BRAKE GROUP—Stop, Turn and Park—Part 2 of 3  
 Serial No. 79U4506 to 79U4553 inclusive

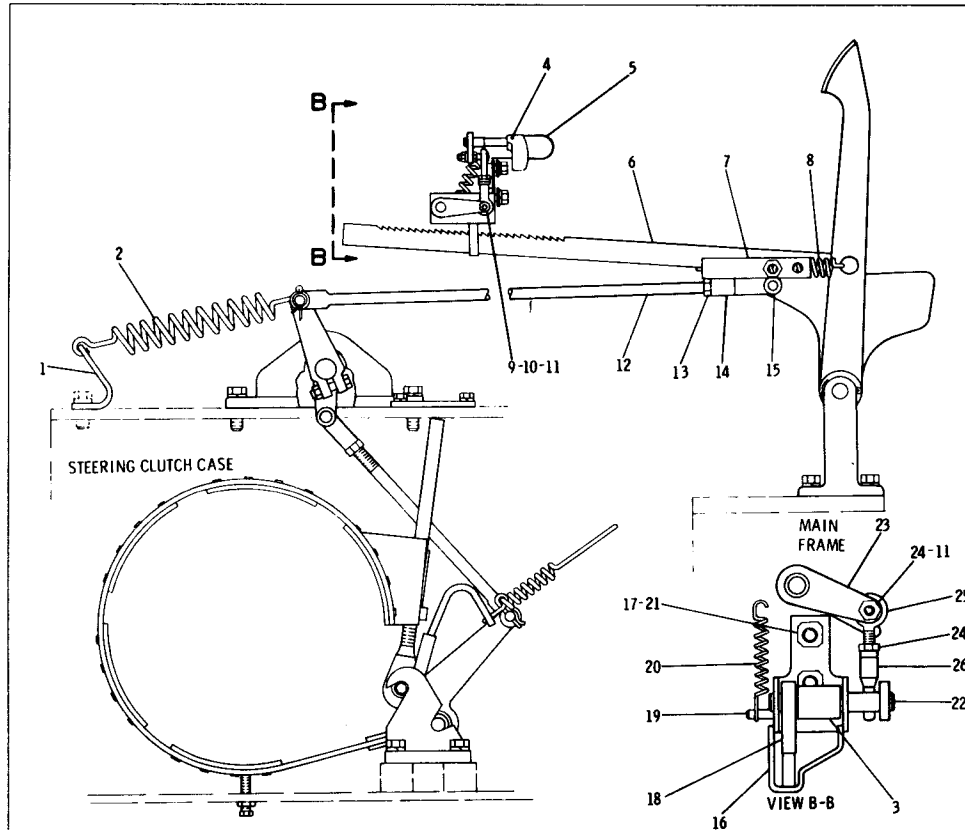

REF. NO.	PART NUMBER	DESCRIPTION	QTY
1	6S9477	PLATE-----	2
2	6S9478	SPRING-----	2
3	6S4183	SPACER-----	1
4	3K4897	PIN-----	1
5	4D506	HANDLE-----	1
6	6S9427	RATCHET-----	1
7	6S4684	PLATE-----	2
8	4B6493	SPRING-----	2
C 9	S1616	BOLT-----	1
10	1B4427	NUT-----	1
11	3B4504	LOCKWASHER-----	2
12	2H9300	ROD-----	2
13	1B4430	NUT-----	2
14	6S6793	ROD END-----	2
15	S175	PIN-----	2
16	3B4617	COTTER PIN-----	2
17	6S4182	BRACKET ASSEM.-----	1
18	9F2978	NUT-----	2
19	6S9541	PAWL ASSEM.-----	1
		(Includes)	
20	5K2823	PIN-----	1
21	5K2823	PIN-----	1
22	3Y2806	SPRING-----	1
23	S1594	BOLT-----	2
24	3B4506	LOCKWASHER-----	2
25	4B4278	WASHER-----	2
C 26	5G693	LEVER ASSEM.-----	1
C 27	5G694	LEVER ASSEM.-----	1
28	9M1311	NUT-----	2
29	6S4199	ROD END-----	1
30	6L7751	ROD END-----	1

C INDICATES CHANGE

217141

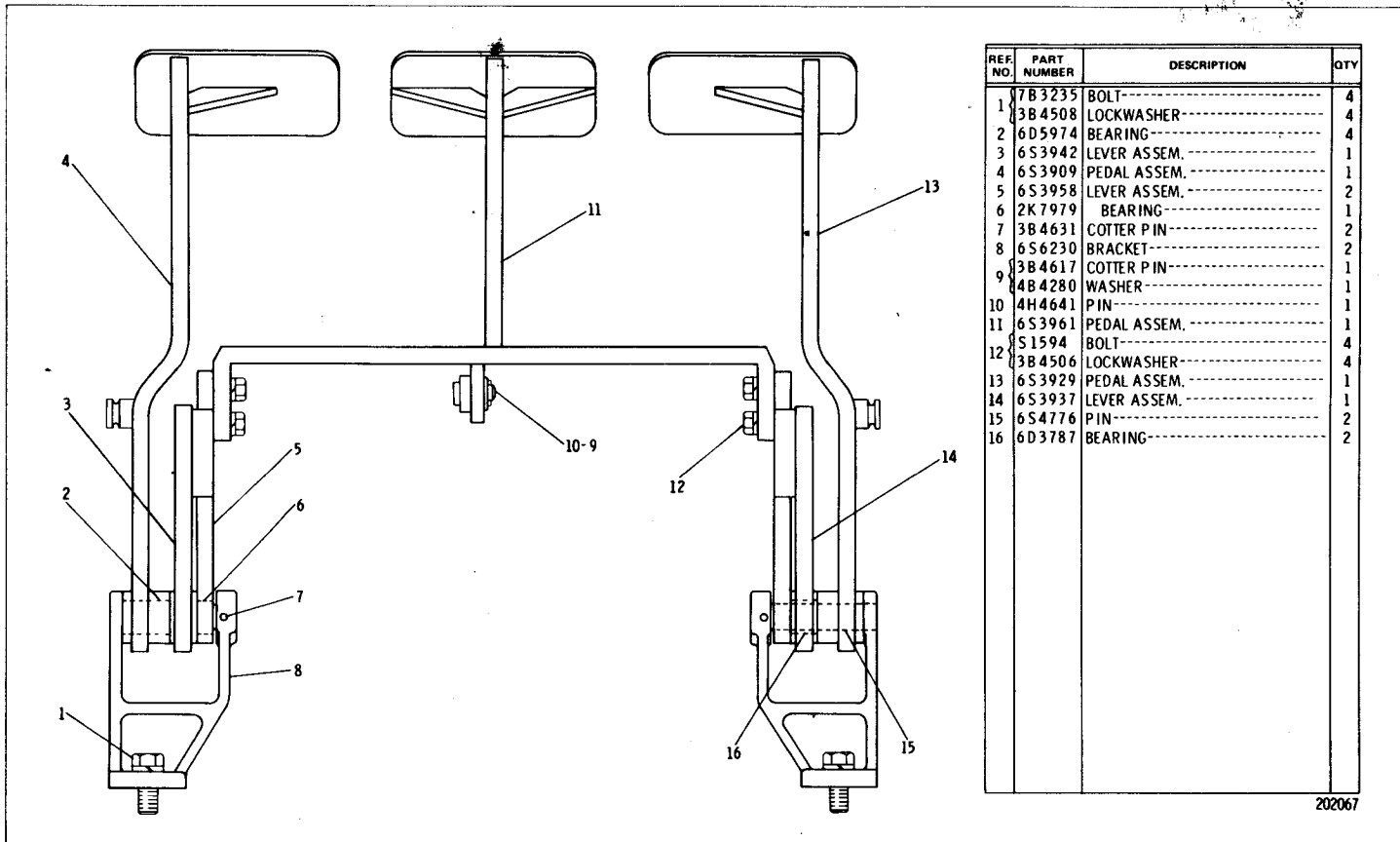

202067

6S3529 STEERING BRAKE GROUP—Stop, Turn and Park—Part 3 of 3  
 Serial No. 79U4506 to 79U4553 inclusive

6S3529 STEERING BRAKE GROUP—Stop, Turn and Park—Part 1 of 3  
 Serial No. 79U4554—Up  
 5G1073 Brake Band Lining parts are shown on Page 48H

REF. NO.	PART NUMBER	DESCRIPTION	QTY.
1	S1585	BOLT-----38.10 mm(1.50 in.)long-	8
2	6S3827	LEVER-----	2
	1B8736	KEY-----	2
3	S1571	BOLT-----	4
	1D4717	NUT-----	4

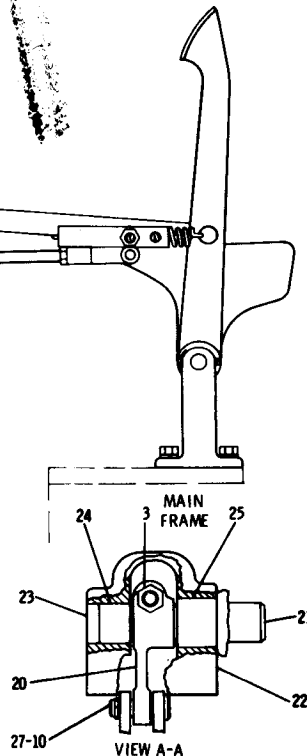
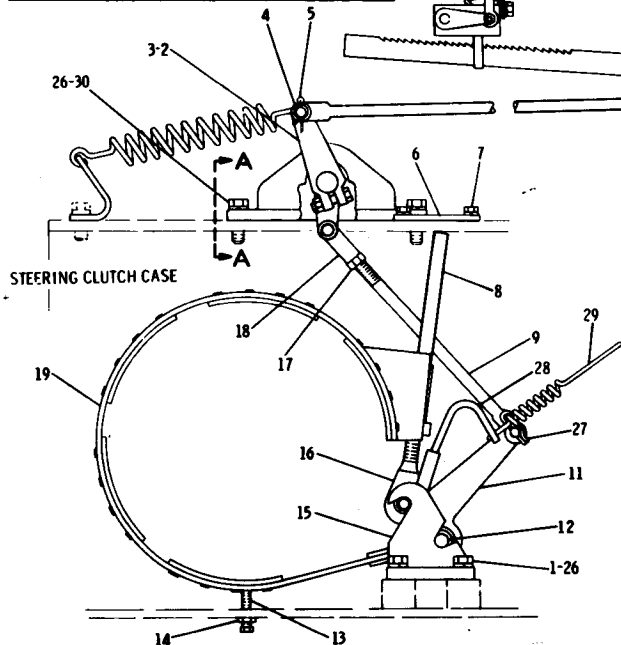

4	3H1977	PIN-----	2
	4B4280	WASHER-----	2
5	3B4617	COTTER PIN-----	2
C	5G1275	COVER-----	2
C	5G1274	GASKET-----	2
7	1L1351	BOLT-----	4
	3B4506	LOCKWASHER-----	4
8	6S4244	NUT ASSEM.-----	2
9	1M1959	ROD-----	2
C	S175	PIN-----35.50 mm(1.39 in.)long	4
10		-OR-	
	5G1492	PIN-----36 mm(1.41 in.)long	4
11	6S3725	LEVER-----	2
12	6S3447	PIN-----	4
13	4B3610	SCREW-----	2
14	1B2578	NUT-----	2
15	6S3455	ANCHOR ASSEM.-----	2
16	7H3788	FORK-----	2
17	1B4430	NUT-----	2
18	1J8964	ROD END-----	2
19	5G1073	BRAKE BAND ASSEM.-----	2
		(Separate Illustration)	
20	6B8408	LEVER-----	2
	1B8706	KEY-----	2
	6S3449	SHAFT----- (R. H.)-----	1
21	6S3448	SHAFT----- (L. H.)-----	1
22	6S9249	HOUSING ASSEM.-----	2
23	4K8603	PLUG-----	1
24	8H8175	BEARING-----	1
25	3K1845	BEARING-----	1
26	3B4508	LOCKWASHER-----	16
27	6S6646	COTTER PIN-----	4
28	6S9438	PLATE ASSEM.-----	2
29	7D5289	SPRING-----	2
30	S1595	BOLT-----31.75 mm(1.25 in.)long	8

C INDICATES CHANGE

175309

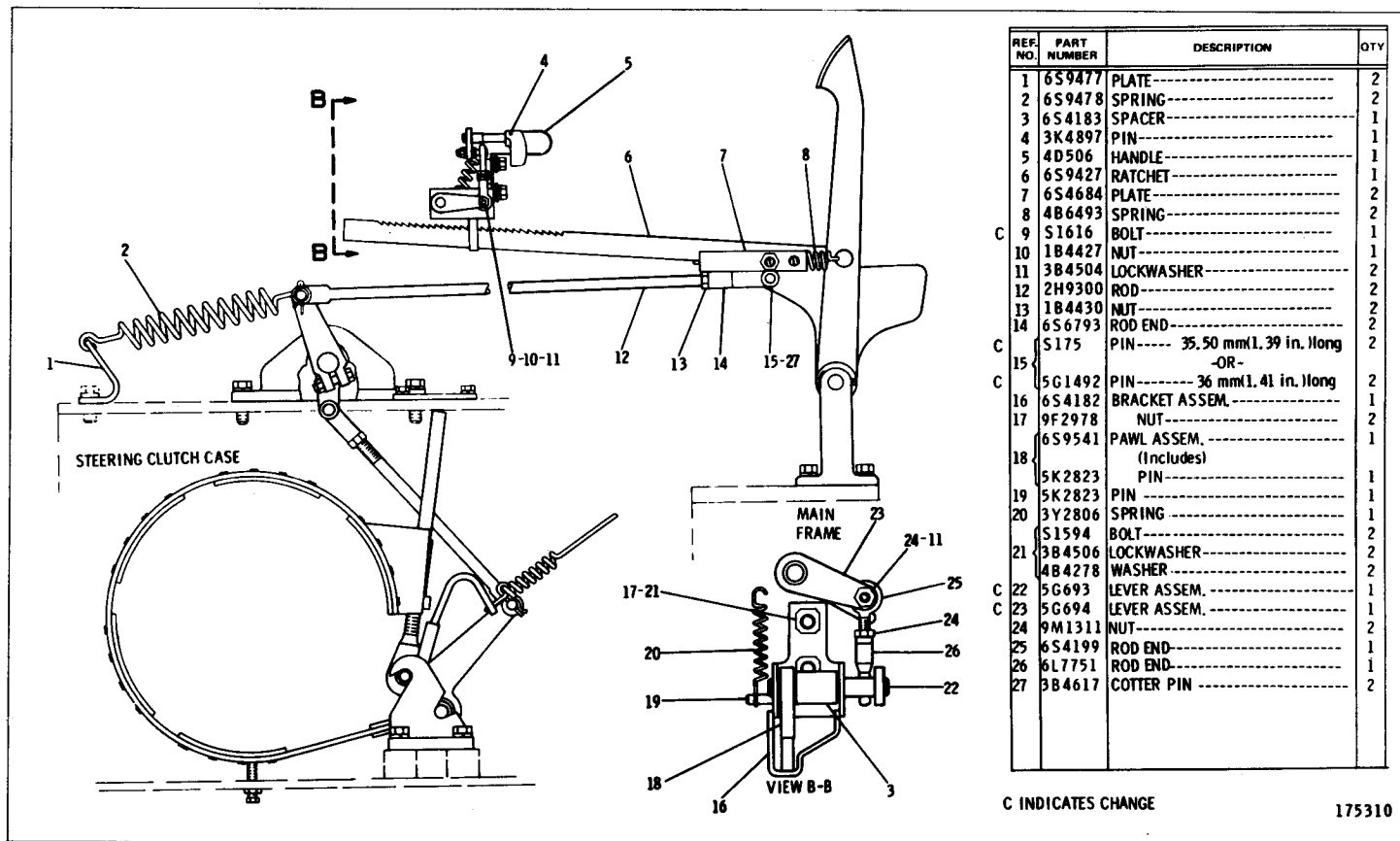

6S3529 STEERING BRAKE GROUP—Stop, Turn and Park—Part 2 of 3  
Serial No. 79U4554—Up

6S3529 STEERING BRAKE GROUP—Stop, Turn and Park—Part 3 of 3  
 Serial No. 79U4554—Up

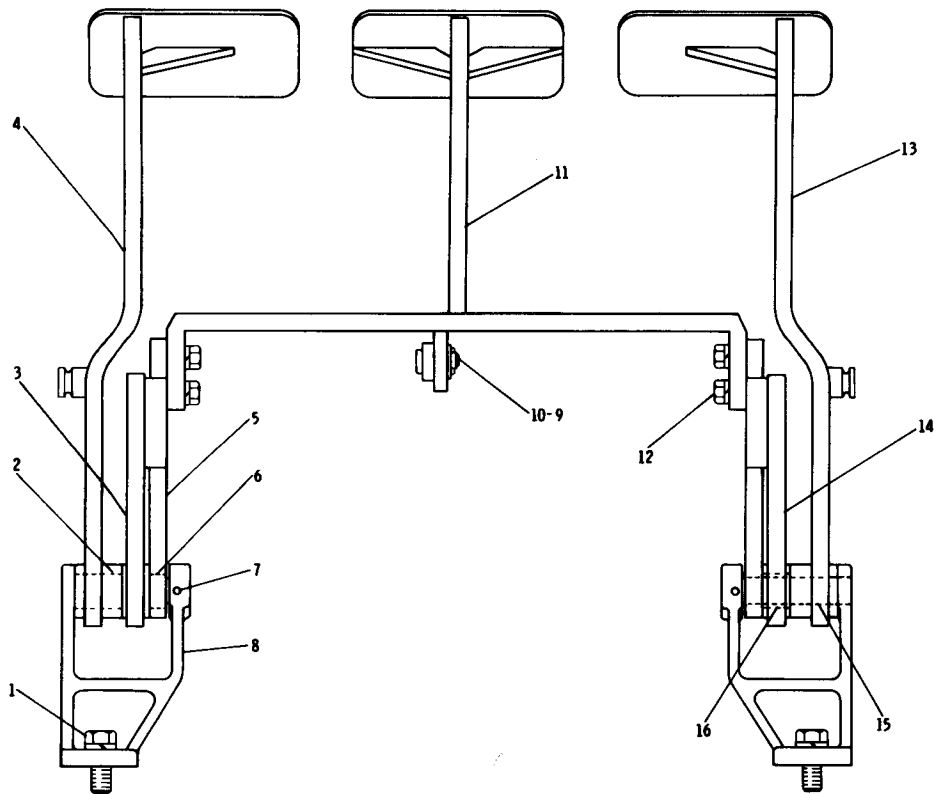

REF. NO.	PART NUMBER	DESCRIPTION	QTY
1	7B3235	BOLT-----	4
2	3B4508	LOCKWASHER-----	4
3	6D5974	BEARING-----	4
4	6S3942	LEVER ASSEM.-----	1
4	6S3909	PEDAL ASSEM.-----	1
5	6S3958	LEVER ASSEM.-----	2
6	2K7979	BEARING-----	1
7	3B4631	COTTER PIN-----	2
8	6S6230	BRACKET-----	2
9	3B4617	COTTER PIN-----	1
9	4B4280	WASHER-----	1
10	4H4641	PIN-----	1
11	6S3961	PEDAL ASSEM.-----	1
12	S1594	BOLT-----	4
12	3B4506	LOCKWASHER-----	4
13	6S3929	PEDAL ASSEM.-----	1
14	6S3937	LEVER ASSEM.-----	1
15	6S4776	PIN-----	2
16	6D3787	BEARING-----	2

202067

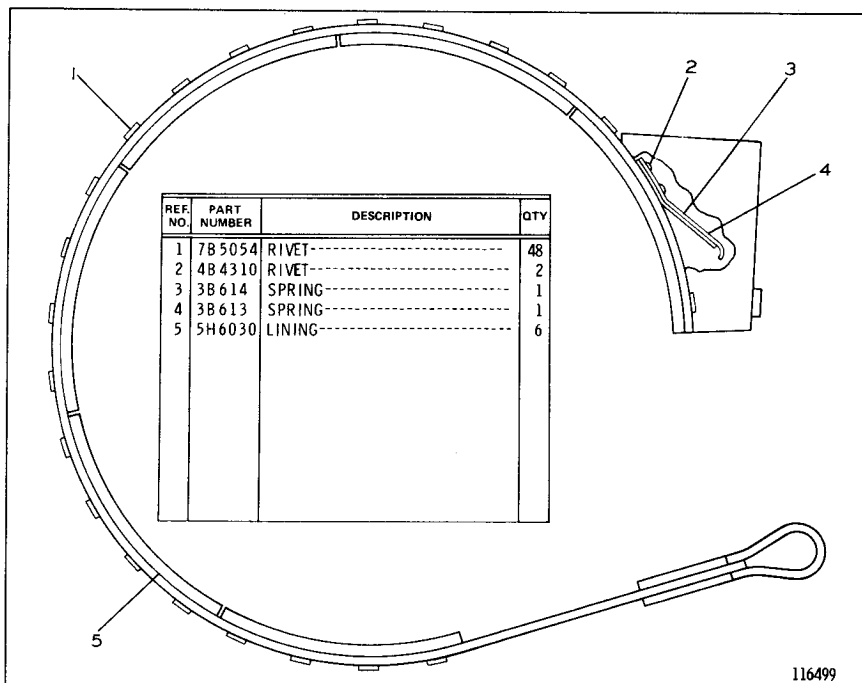

116499

**6S4010 BRAKE BAND LINING ASSEMBLY**  
 Serial No. 79U1 to 79U1599 inclusive  
 Part of 6S3529 Steering Brake Group shown on Pages 46 and 48A

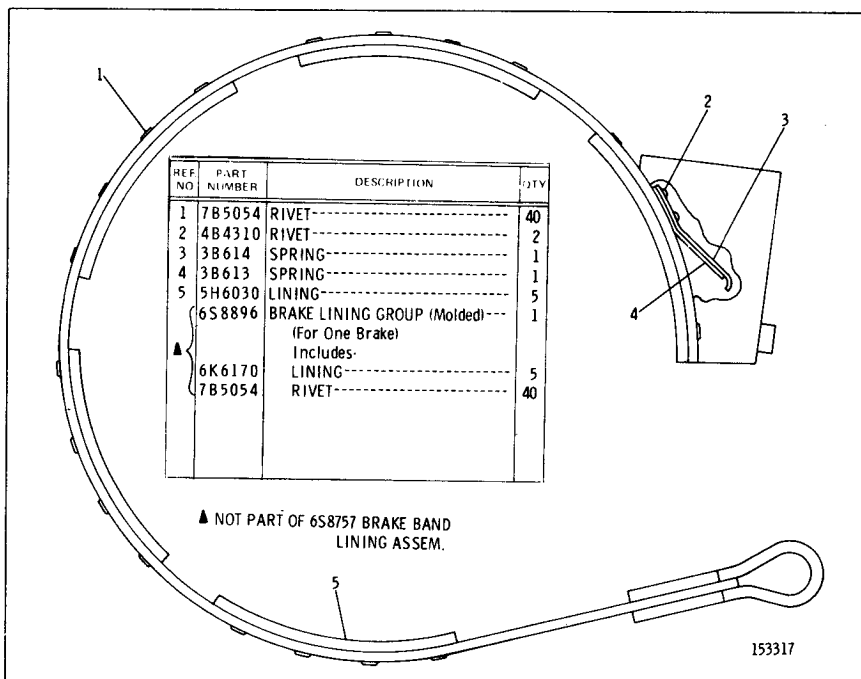

▲ NOT PART OF 6S8757 BRAKE BAND LINING ASSEM.

153317

**6S8757 BRAKE BAND LINING ASSEMBLY**  
 Serial No. 79U1600 to 79U4505 inclusive  
 Part of 6S3529 Steering Brake Group shown on Pages 48D, 48F-1, 48F-4 and 48F-7

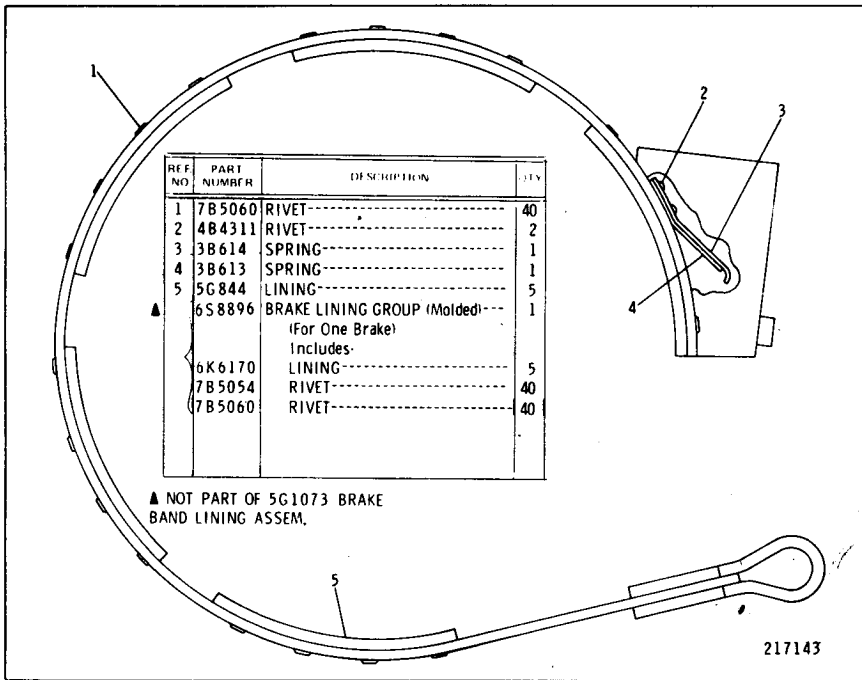

## 5G1073 BRAKE BAND LINING ASSEMBLY

Serial No. 79U4506—Up

Part of 6S3529 Steering Brake Group shown on Pages 48F-10 &amp; 48F-13



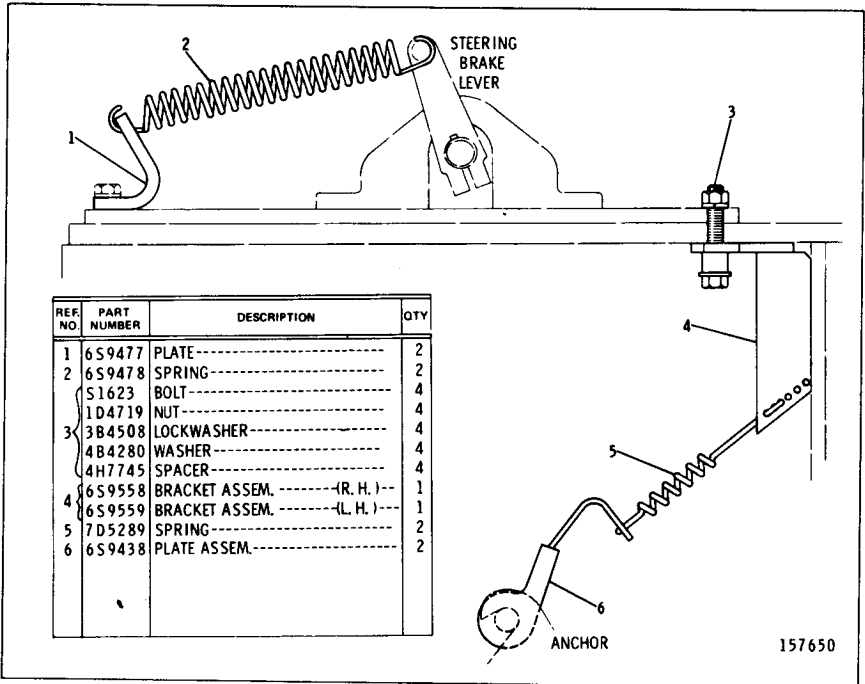

6S9568 BRAKE PARTS SERVICE GROUP  
FOR FIELD FIX TO TRACTORS WITH BRAKE PEDAL KICKBACK  
Serial No. 79U1 to 79U2758 inclusive

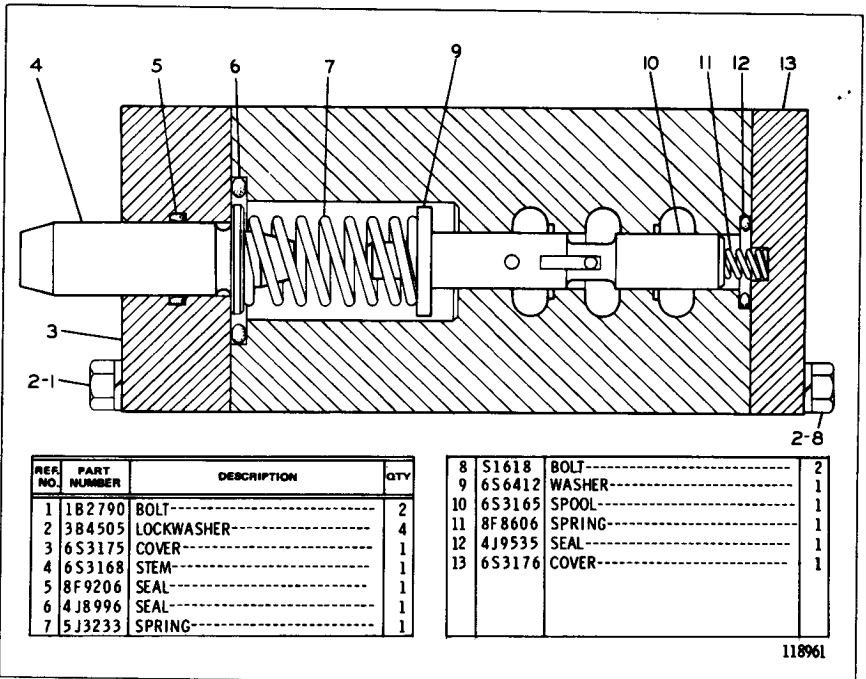

6S3757 CONTROL VALVE GROUP  
Part of 6S3531 Steering Clutch Control Group shown on Pages 50A and 51

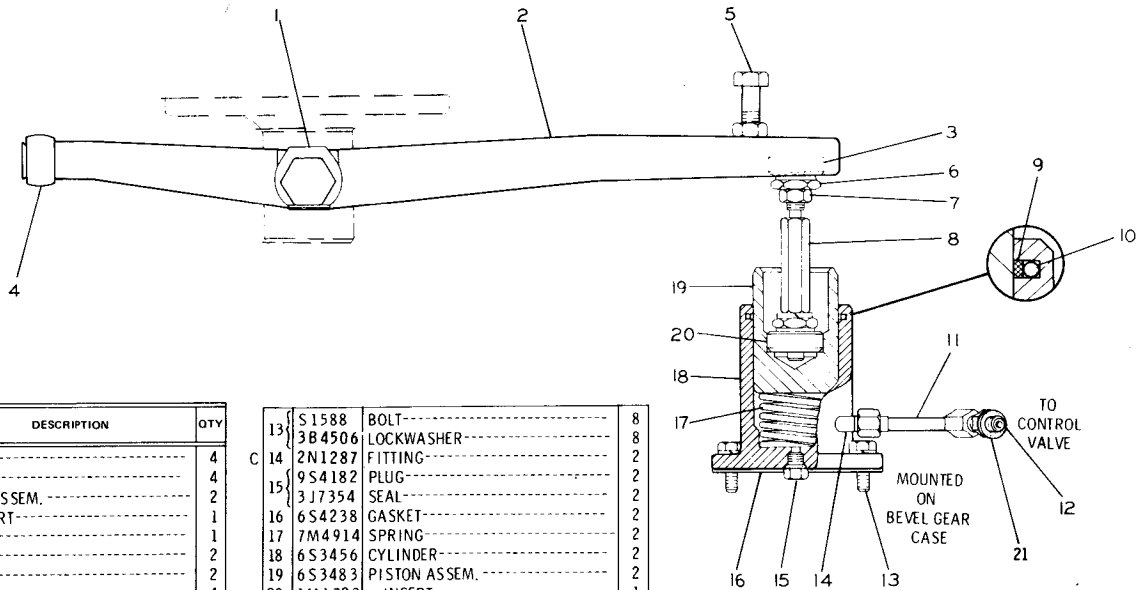

REF NO	PART NUMBER	DESCRIPTION	QTY
	7K8915	SCREW	4
1	T355	LOCK	4
2	6S3838	YOKE ASSEM.	2
3	1M1723	INSERT	1
4	1A7657	BALL	1
5	1A1460	BOLT	2
	1D4719	NUT	2
6	1M1729	NUT	4
7	1B4430	NUT	2
8	6S6125	ROD	2
	3B4508	LOCKWASHER	2
9	6S3479	RING	2
10	1H8720	SEAL	2
11	6S3492	TUBE ASSEM.	2
	2P1276	UNION	2
12	2P1277	NUT	2

13	S1588	BOLT	8
	3B4506	LOCKWASHER	8
C 14	2N1287	FITTING	2
15	9S4182	PLUG	2
	3J7354	SEAL	2
16	6S4238	GASKET	2
17	7M4914	SPRING	2
18	6S3456	CYLINDER	2
19	6S3483	PISTON ASSEM.	2
20	1M1723	INSERT	1
C 21	6B2250	GASKET	1

C INDICATES CHANGE

147607

6S3531 STEERING CLUTCH CONTROL GROUP—Part 1  
Serial No. 79U1 to 79U2197 inclusive

6S3531 STEERING CLUTCH CONTROL GROUP—Part 2  
 Serial No. 79U1 to 79U2197 inclusive  
 6S3757 Valve parts are shown on Page 49

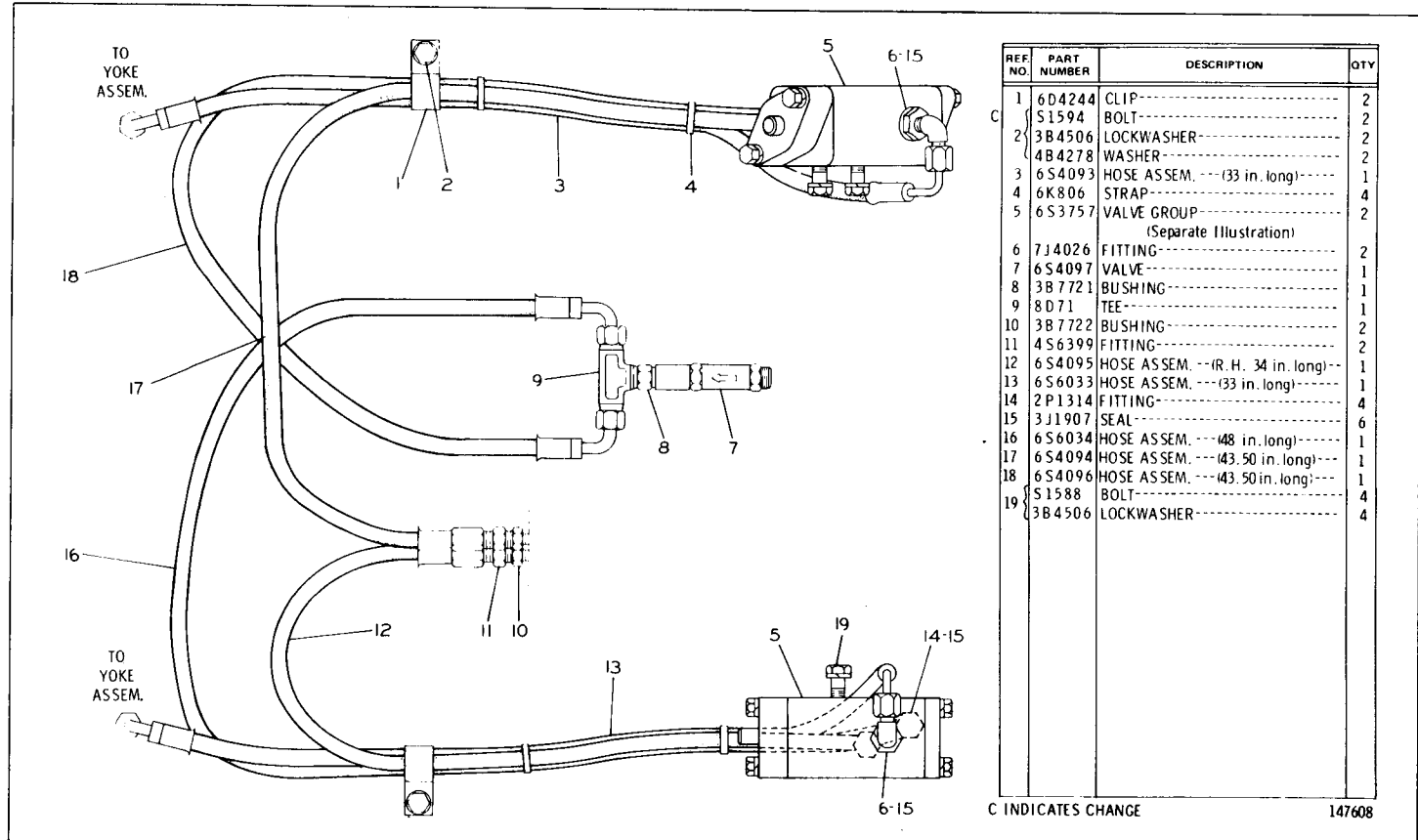

REF. NO.	PART NUMBER	DESCRIPTION	QTY
C	6D4244	CLIP-----	2
	S1594	BOLT-----	2
	3B4506	LOCKWASHER-----	2
	4B4278	WASHER-----	2
	6S4093	HOSE ASSEM. ---(33 in. long)---	1
	6K806	STRAP-----	4
	6S3757	VALVE GROUP (Separate Illustration)	2
	7J4026	FITTING-----	2
	6S4097	VALVE-----	1
	3B7721	BUSHING-----	1
	8D71	TEE-----	1
	3B7722	BUSHING-----	2
	4S6399	FITTING-----	2
	6S4095	HOSE ASSEM. --- (R. H. 34 in. long)---	1
	6S6033	HOSE ASSEM. --- (33 in. long)---	1
	2P1314	FITTING-----	4
	3J1907	SEAL-----	6
	6S6034	HOSE ASSEM. --- (48 in. long)---	1
	6S4094	HOSE ASSEM. --- (43.50 in. long)---	1
6S4096	HOSE ASSEM. --- (43.50 in. long)---	1	
19	S1588	BOLT-----	4
	3B4506	LOCKWASHER-----	4

C INDICATES CHANGE

147608

STEERING CLUTCHES AND BRAKES

50A

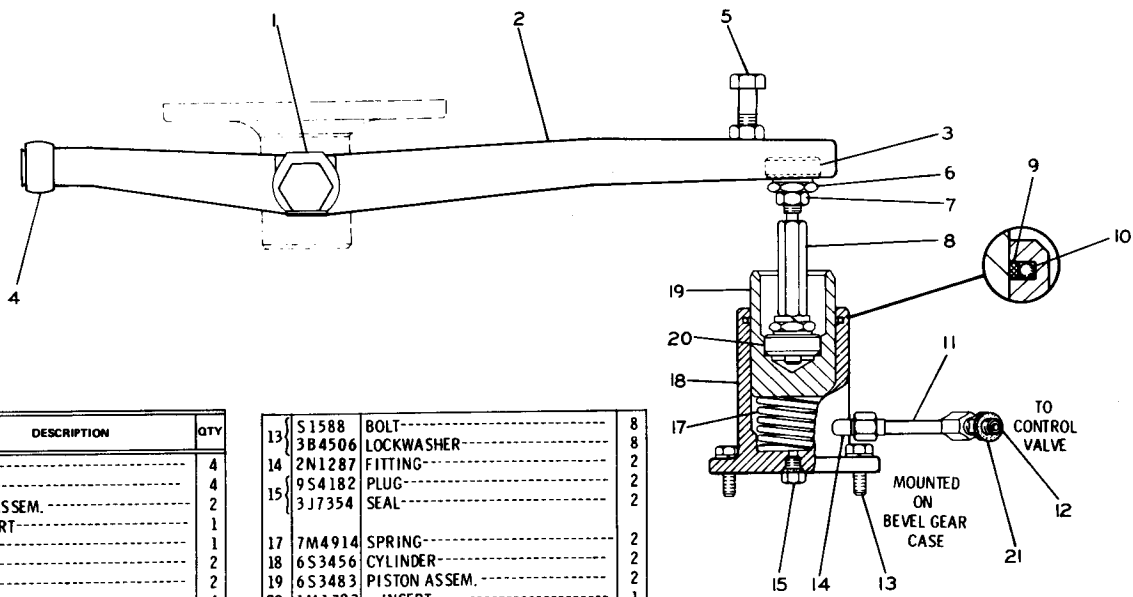

REF. NO.	PART NUMBER	DESCRIPTION	QTY
1	7K8915	SCREW-----	4
1	T355	LOCK-----	4
2	6S3838	YOKE ASSEM.-----	2
3	1M1723	INSERT-----	1
4	1A7657	BALL-----	1
5	1A1460	BOLT-----	2
5	1D4719	NUT-----	2
6	1M1729	NUT-----	4
7	1B4430	NUT-----	2
8	6S6125	ROD-----	2
8	3B4508	LOCKWASHER-----	2
9	6S3479	RING-----	2
10	1H8720	SEAL-----	2
11	6S3492	TUBE ASSEM.-----	2
12	2P1276	UNION-----	2
12	5B3254	NUT-----	2

13	51588	BOLT-----	8
14	3B4506	LOCKWASHER-----	8
14	2N1287	FITTING-----	2
15	9S4182	PLUG-----	2
15	3J7354	SEAL-----	2
17	7M4914	SPRING-----	2
18	6S3456	CYLINDER-----	2
19	6S3483	PISTON ASSEM.-----	2
20	1M1723	INSERT-----	1
21	6B2250	GASKET-----	1

C INDICATES CHANGE

156317

6S3531 STEERING CLUTCH CONTROL GROUP—Part 1  
Serial No. 79U2198 to 79U4439 inclusive

6S3531 STEERING CLUTCH CONTROL GROUP—Part 2  
 Serial No. 79U2198 to 79U4439 inclusive  
 6S3757 Valve parts are shown on Page 49

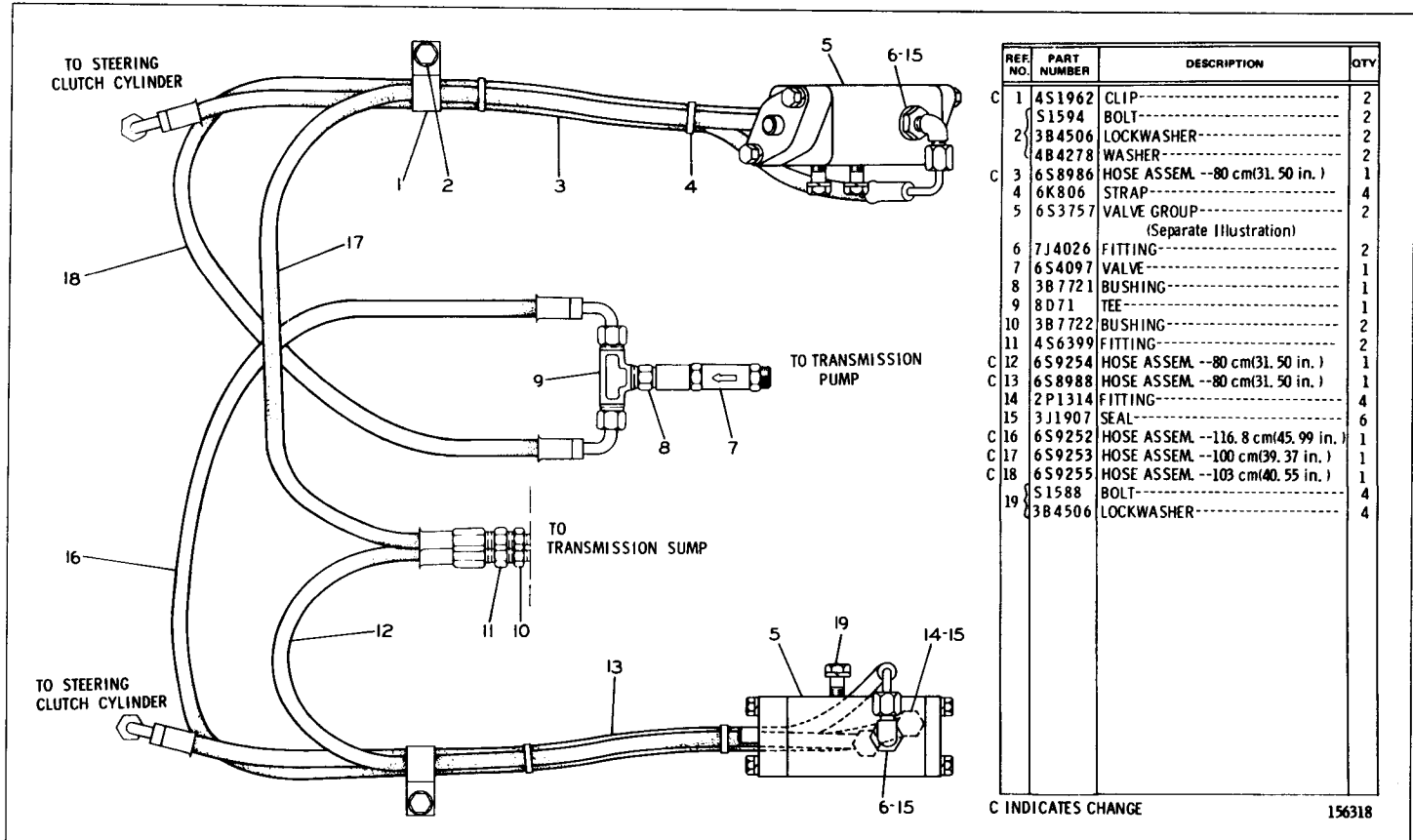

REF. NO.	PART NUMBER	DESCRIPTION	QTY
C 1	4S1962	CLIP-----	2
	S1594	BOLT-----	2
2	3B4506	LOCKWASHER-----	2
	4B4278	WASHER-----	2
C 3	6S8986	HOSE ASSEM. --80 cm(31.50 in.)	1
4	6K806	STRAP-----	4
5	6S3757	VALVE GROUP (Separate Illustration)	2
6	7J4026	FITTING-----	2
7	6S4097	VALVE-----	1
8	3B7721	BUSHING-----	1
9	8D71	TEE-----	1
10	3B7722	BUSHING-----	2
11	4S6399	FITTING-----	2
C 12	6S9254	HOSE ASSEM. --80 cm(31.50 in.)	1
C 13	6S8988	HOSE ASSEM. --80 cm(31.50 in.)	1
14	2P1314	FITTING-----	4
15	3J1907	SEAL-----	6
C 16	6S9252	HOSE ASSEM. --116.8 cm(45.99 in.)	1
C 17	6S9253	HOSE ASSEM. --100 cm(39.37 in.)	1
C 18	6S9255	HOSE ASSEM. --103 cm(40.55 in.)	1
19	S1588	BOLT-----	4
	3B4506	LOCKWASHER-----	4

C INDICATES CHANGE

156318

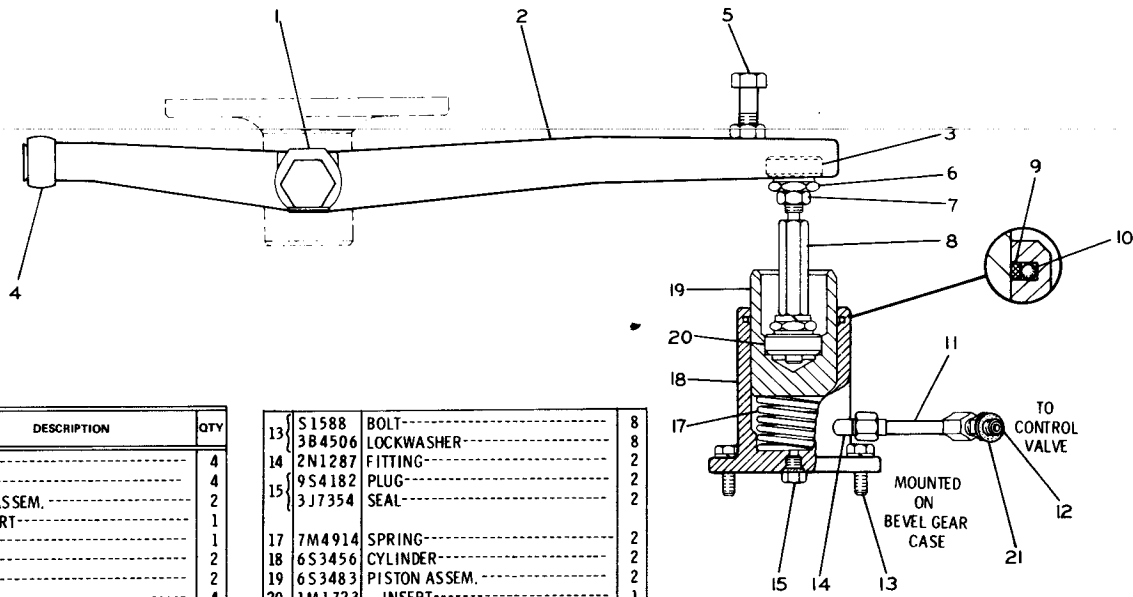

REF. NO.	PART NUMBER	DESCRIPTION	QTY
1	7K8915	SCREW-----	4
	T355	LOCK-----	4
2	6S3838	YOKE ASSEM.-----	2
3	1M1723	INSERT-----	1
4	1A7657	BALL-----	1
5	1A1460	BOLT-----	2
	1D4719	NUT-----	2
6	1M1729	NUT-----	4
7	1B4430	NUT-----	2
8	6S6125	ROD-----	2
	3B4508	LOCKWASHER-----	2
9	6S3479	RING-----	2
10	1H8720	SEAL-----	2
11	6S3492	TUBE ASSEM.-----	2
12	2P1276	UNION-----	2
	5B3254	NUT-----	2

13	S1588	BOLT-----	8
	3B4506	LOCKWASHER-----	8
	2N1287	FITTING-----	2
14	9S4182	PLUG-----	2
	3J7354	SEAL-----	2
17	7M4914	SPRING-----	2
	6S3456	CYLINDER-----	2
19	6S3483	PISTON ASSEM.-----	2
20	1M1723	INSERT-----	1
21	6B2250	GASKET-----	1

C INDICATES CHANGE

156317

6S3531 STEERING CLUTCH CONTROL GROUP—Part 1  
Serial No. 79U4440 to 79U4561 inclusive

6S3531 STEERING CLUTCH CONTROL GROUP—Part 2  
 Serial No. 79U4440 to 79U4561 inclusive  
 5G913 Valve parts are shown on Page 51F

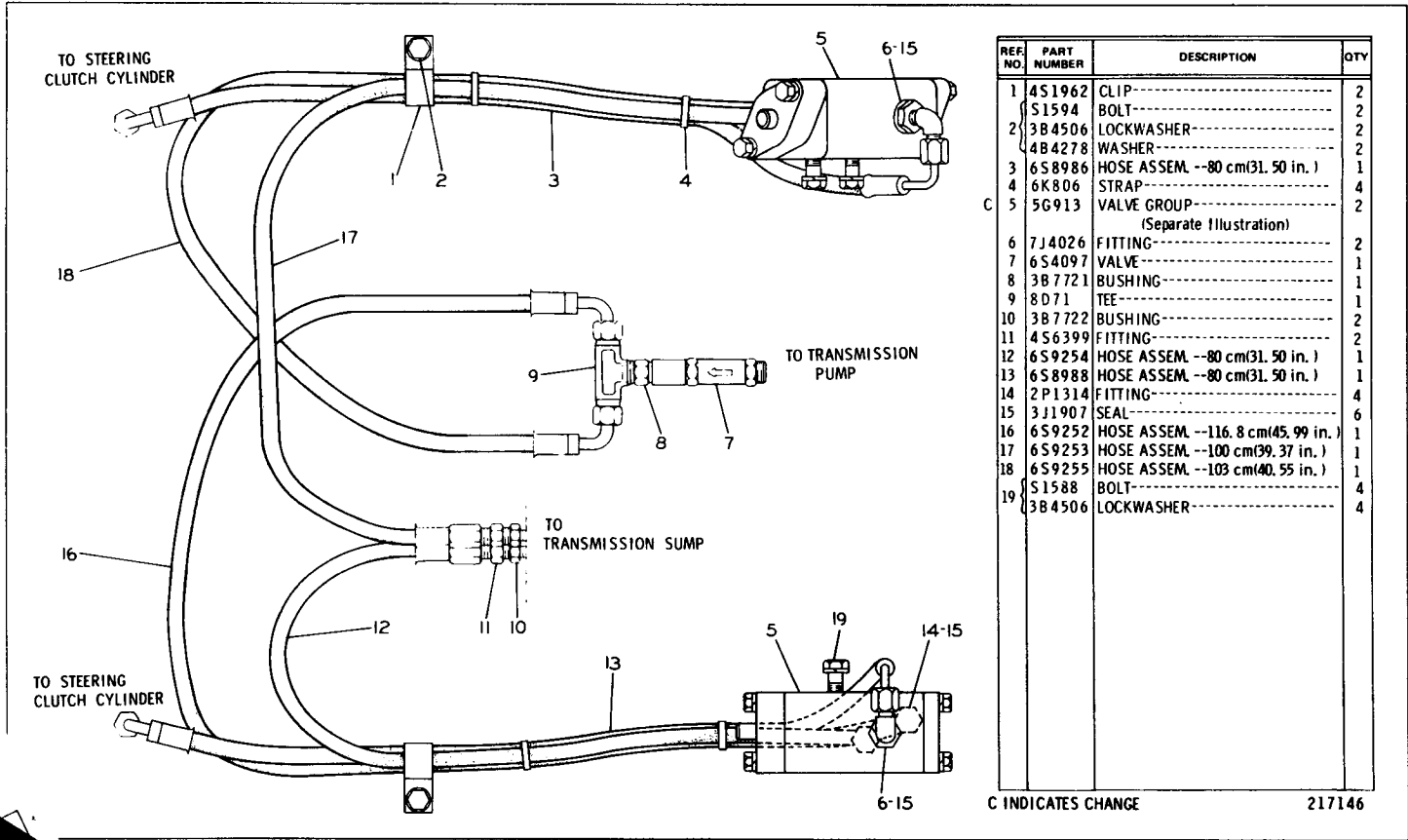

STEERING CLUTCHES AND BRAKES

51B

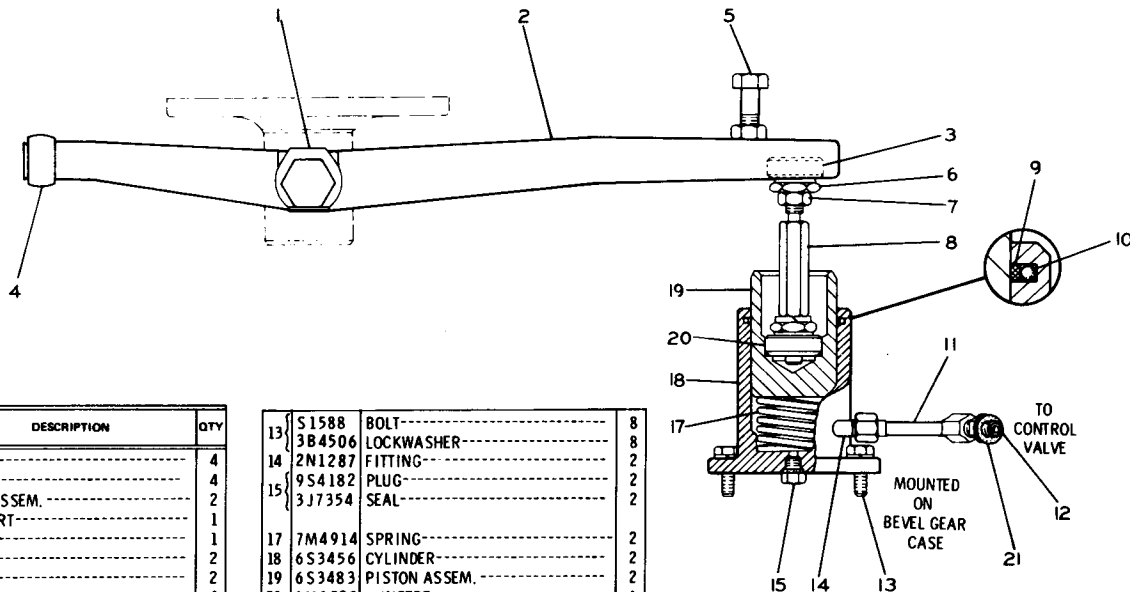

REF. NO.	PART NUMBER	DESCRIPTION	QTY
1	7K8915	SCREW-----	4
	T355	LOCK-----	4
2	6S3838	YOKE ASSEM.-----	2
3	1M1723	INSERT-----	1
4	1A7657	BALL-----	1
5	1A1460	BOLT-----	2
	1D4719	NUT-----	2
6	1M1729	NUT-----	4
7	1B4430	NUT-----	2
8	6S6125	ROD-----	2
	3B4508	LOCKWASHER-----	2
9	6S3479	RING-----	2
10	1H8720	SEAL-----	2
11	6S3492	TUBE ASSEM.-----	2
12	2P1276	UNION-----	2
	5B3254	NUT-----	2

13	51588	BOLT-----	8
	3B4506	LOCKWASHER-----	8
14	2N1287	FITTING-----	2
15	9S4182	PLUG-----	2
	3J7354	SEAL-----	2
17	7M4914	SPRING-----	2
18	6S3456	CYLINDER-----	2
19	6S3483	PISTON ASSEM.-----	2
20	1M1723	INSERT-----	1
21	6B2250	GASKET-----	1

C INDICATES CHANGE

15617

6S3531 STEERING CLUTCH CONTROL GROUP—Part 1  
Serial No. 79U4562—Up



6S3531 STEERING CLUTCH CONTROL GROUP—Part 2  
 Serial No. 79U4562—Up  
 6S9580 Valve parts are shown on Page 51F

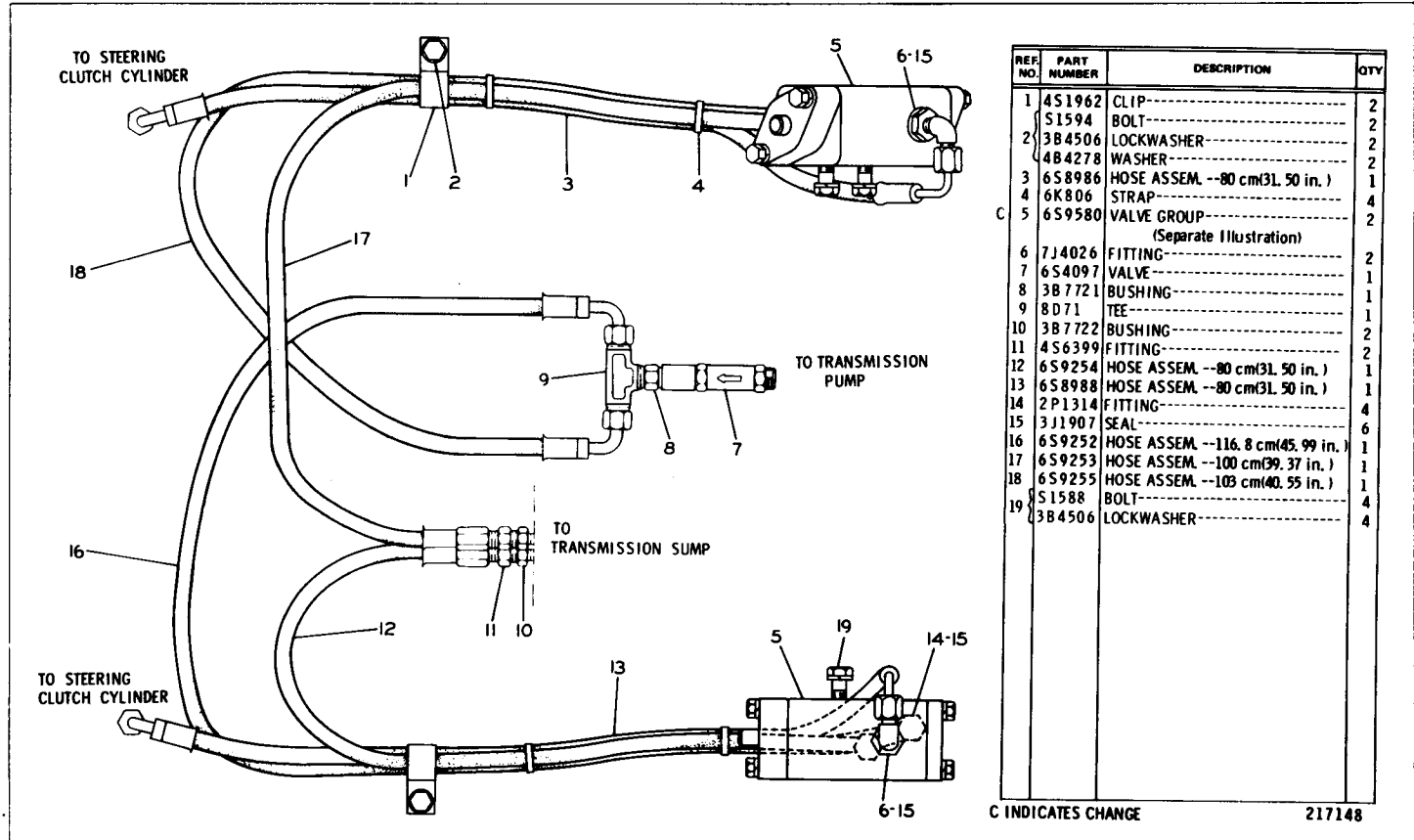

REF. NO.	PART NUMBER	DESCRIPTION	QTY
1	4S1962	CLIP-----	2
	S1594	BOLT-----	2
2	3B4506	LOCKWASHER-----	2
	4B4278	WASHER-----	2
3	6S8986	HOSE ASSEM. --80 cm(31.50 in.)	1
4	6K806	STRAP-----	4
C 5	6S9580	VALVE GROUP (Separate Illustration)	2
6	7J4026	FITTING-----	2
7	6S4097	VALVE-----	1
8	3B7721	BUSHING-----	1
9	8D71	TEE-----	1
10	3B7722	BUSHING-----	2
11	4S6399	FITTING-----	2
12	6S9254	HOSE ASSEM. --80 cm(31.50 in.)	1
13	6S8988	HOSE ASSEM. --80 cm(31.50 in.)	1
14	2P1314	FITTING-----	4
15	3J1907	SEAL-----	6
16	6S9252	HOSE ASSEM. --116.8 cm(45.99 in.)	1
17	6S9253	HOSE ASSEM. --100 cm(39.37 in.)	1
18	6S9255	HOSE ASSEM. --103 cm(40.55 in.)	1
19	S1588	BOLT-----	4
	3B4506	LOCKWASHER-----	4

C INDICATES CHANGE

217148

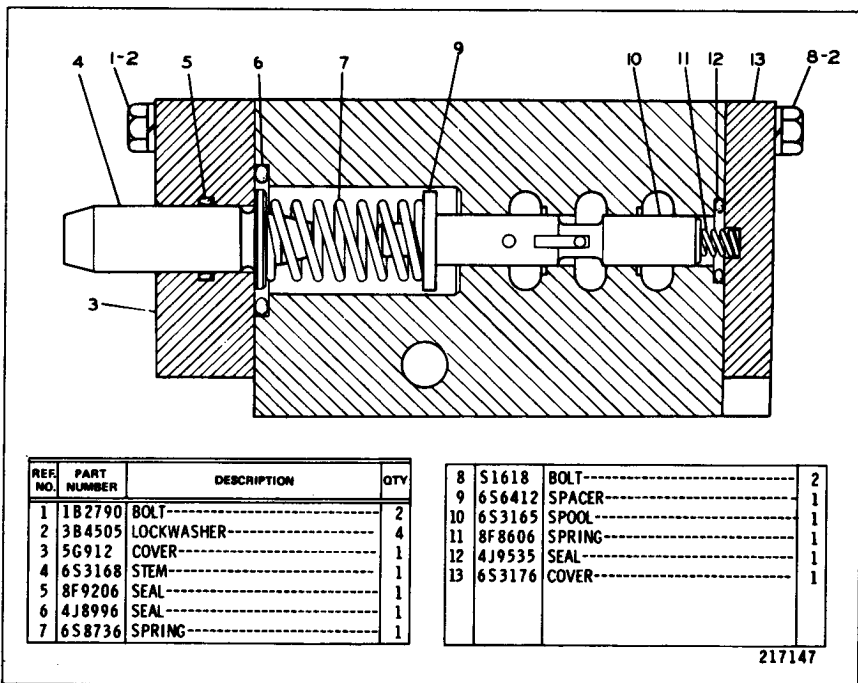

5G913 CONTROL VALVE GROUP  
 Serial No. 79U4440 to 79U4561 inclusive  
 Part of 6S3531 Steering Clutch Control Group shown on Page 51B

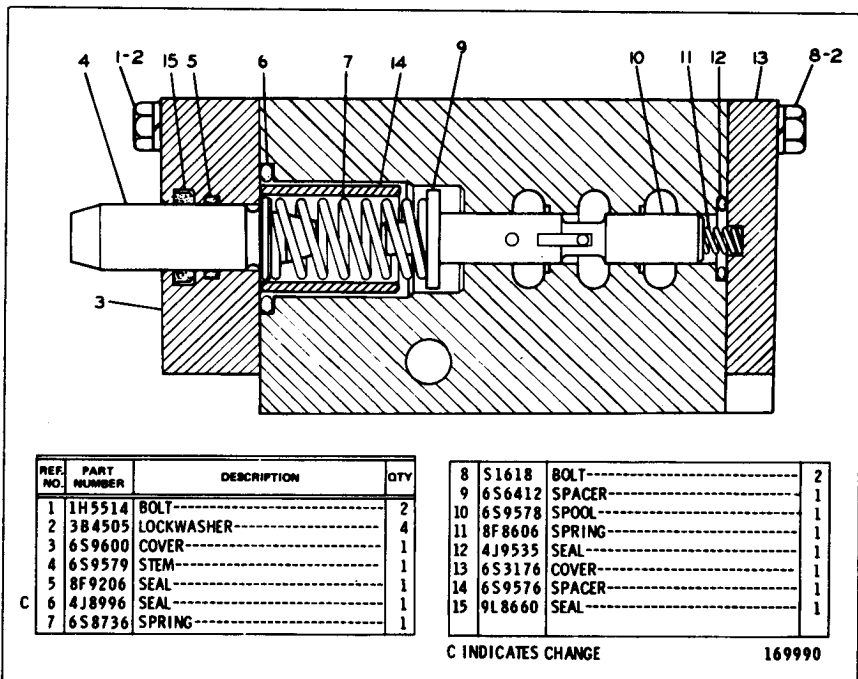

6S9580 CONTROL VALVE GROUP  
 Serial No. 79U4562—Up  
 Part of 6S3531 Steering Clutch Control Group shown on Page 51D

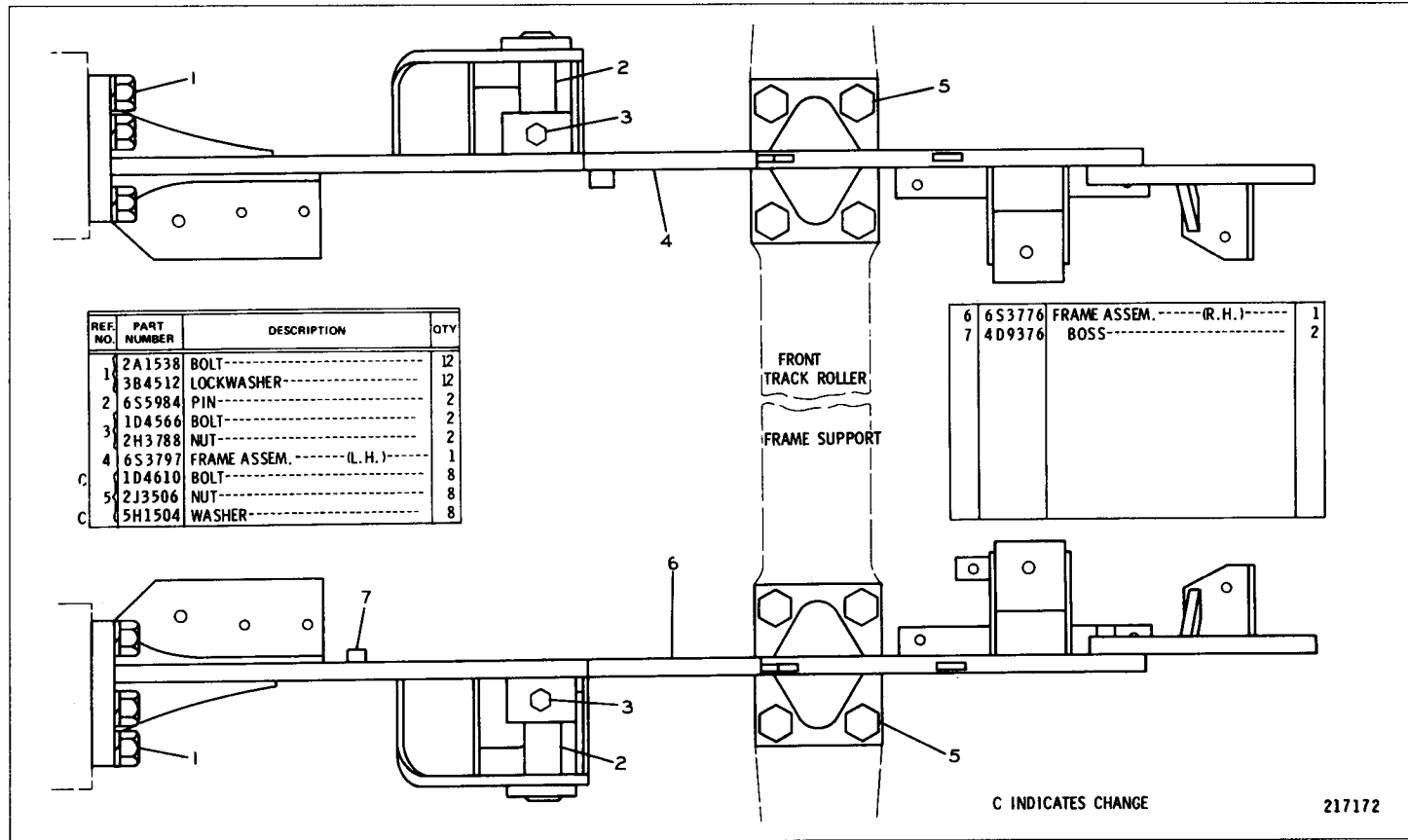

## 6S3406 FRAME GROUP

Note: Quantities shown are those required for both R.H. & L.H. sides

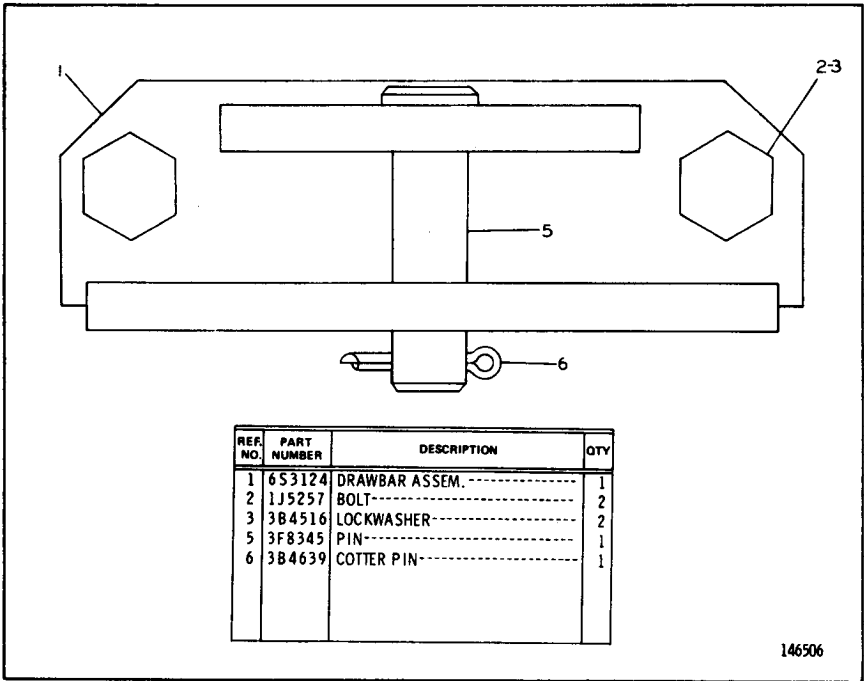

REF. NO.	PART NUMBER	DESCRIPTION	QTY
1	6S3124	DRAWBAR ASSEM.-----	1
2	1J5257	BOLT-----	2
3	3B4516	LOCKWASHER-----	2
5	3F8345	PIN-----	1
6	3B4639	COTTER PIN-----	1

146506

**DRAWBAR (6S3508 N/S)**

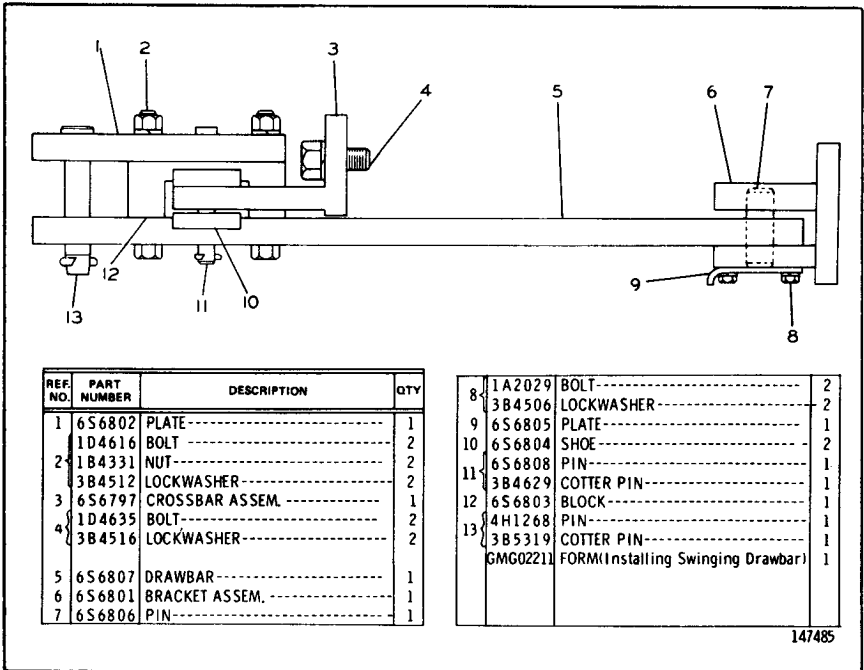

REF. NO.	PART NUMBER	DESCRIPTION	QTY
1	6S6802	PLATE-----	1
	1D4616	BOLT-----	2
2	1B4331	NUT-----	2
	3B4512	LOCKWASHER-----	2
3	6S6797	CROSSBAR ASSEM.-----	1
	1D4635	BOLT-----	2
4	3B4516	LOCKWASHER-----	2
5	6S6807	DRAWBAR-----	1
6	6S6801	BRACKET ASSEM.-----	1
7	6S6806	PIN-----	1

8	1A2029	BOLT-----	2
	3B4506	LOCKWASHER-----	2
9	6S6805	PLATE-----	1
10	6S6804	SHOE-----	2
	6S6808	PIN-----	1
11	3B4629	COTTER PIN-----	1
12	6S6803	BLOCK-----	1
	4H1268	PIN-----	1
13	3B5319	COTTER PIN-----	1
	GMG0221	FORM(Installing Swinging Drawbar)	1

147485

**6S6809 SWINGING DRAWBAR GROUP  
AN ATTACHMENT**

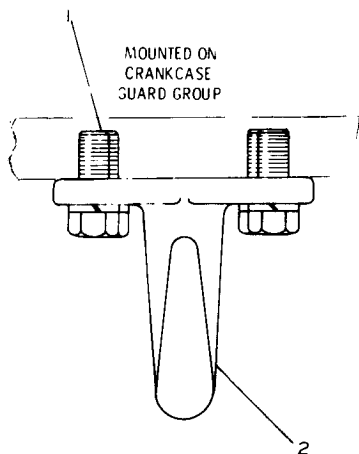

REF. NO.	PART NUMBER	DESCRIPTION	QTY
1	11178	BOLT-----	4
	384512	LOCKWASHER-----	4
2	5K8907	HOO-----	1

116852

6S3864 FRONT PULL HOOK GROUP  
CANNOT BE USED WITH 5G441 FRONT COUNTERWEIGHT GROUP SHOWN ON  
PAGE 60-2. AN ATTACHMENT

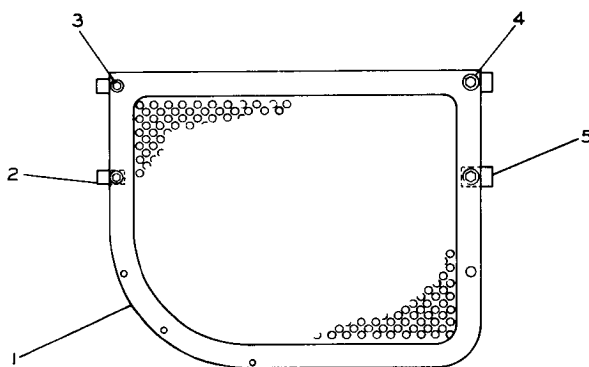

REF. NO.	PART NUMBER	DESCRIPTION	QTY
1	6S6782	PANEL ASSEM. ----- (R. H.)-----	1
	6S6781	PANEL ASSEM. ----- (L. H.)-----	1
2	2B9828	LUG-----	4
	S509	BOLT-----	4
3	3B4506	LOCKWASHER-----	4
	4B4278	WASHER-----	4

4	647423	BOLT-----	4
	4B4279	WASHER-----	4
	6S6709	SPACER-----	4
	5 6S6754	PLATE ASSEM.-----	4

116865

## 6S7195 ENGINE ENCLOSURE GROUP

Note: Quantities shown are those required for both R.H. and L.H. sides  
AN ATTACHMENT

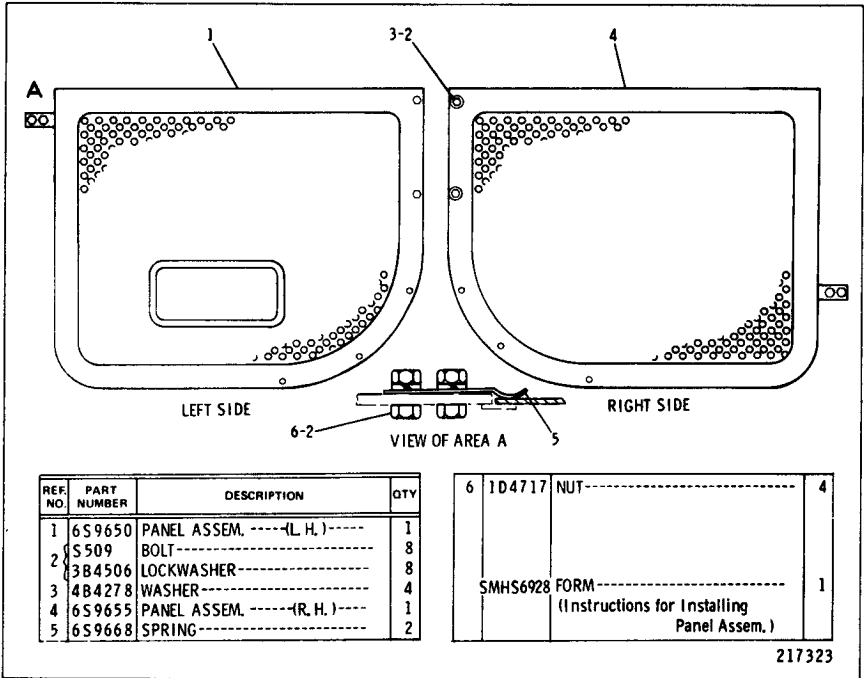

5G936 ENGINE ENCLOSURE GROUP  
FOR USE WITH 5G1177 LINES AND PUMP GROUP SHOWN ON  
PAGES 80D AND 80E. AN ATTACHMENT

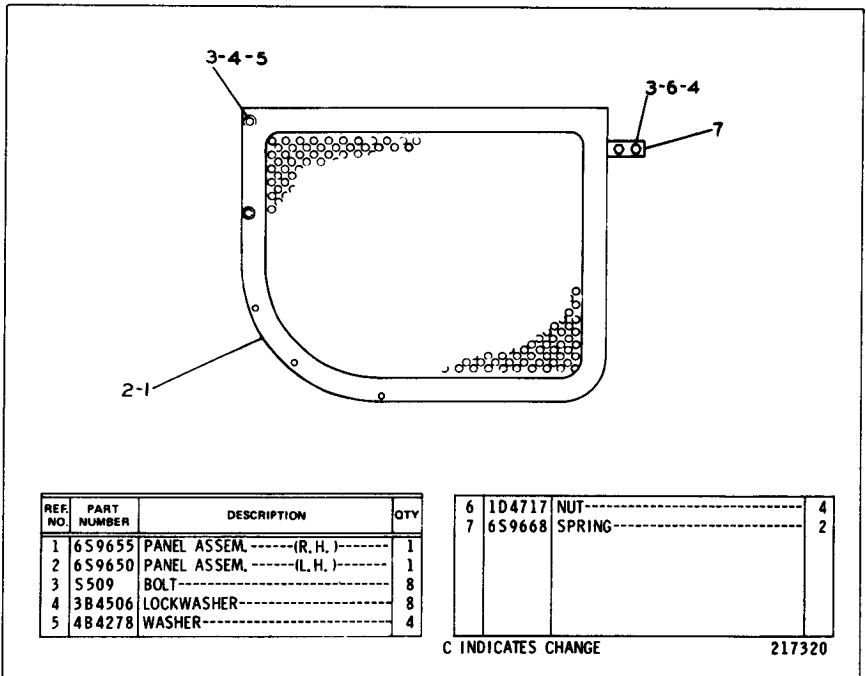

6S9698 ENGINE ENCLOSURE GROUP

Note: Quantities shown are those required for both R.H. and L.H. sides  
AN ATTACHMENT

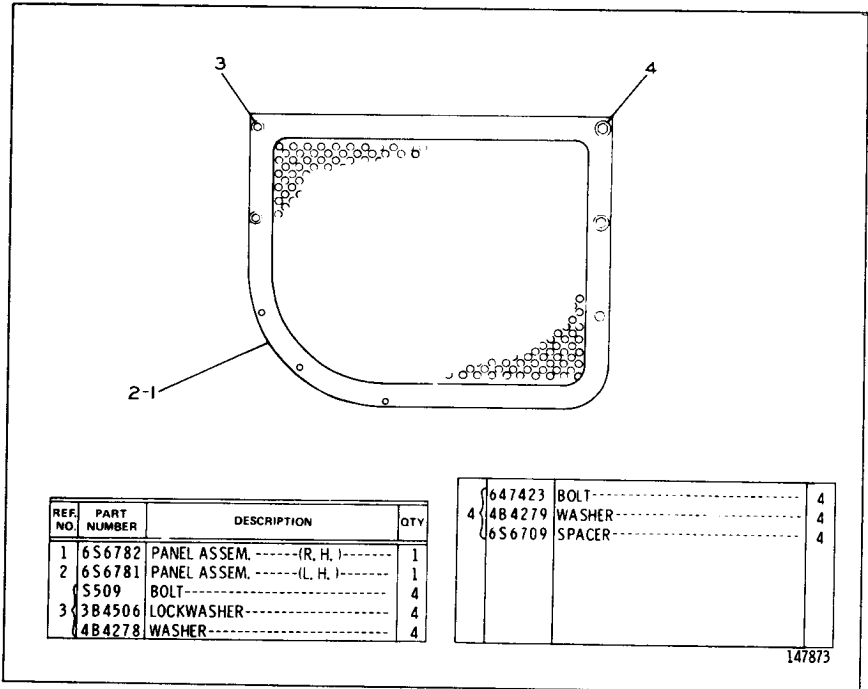

6S6785 ENGINE ENCLOSURE GROUP—Type 1

Note: Quantities shown are those required for both R.H. and L.H. sides AN ATTACHMENT

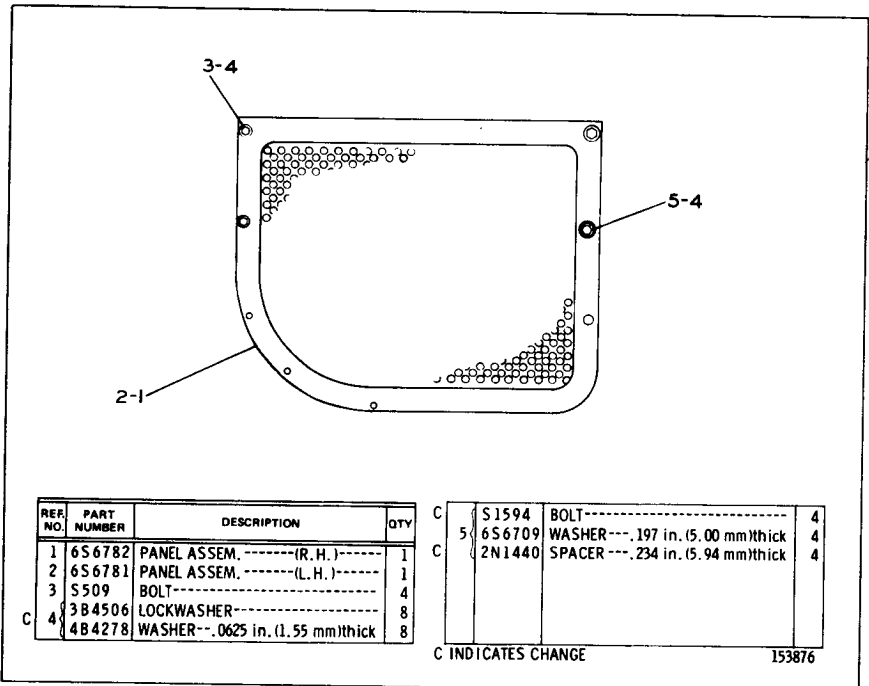

6S6785 ENGINE ENCLOSURE GROUP—Type 2

Note: Quantities shown are those required for both R.H. and L.H. sides AN ATTACHMENT

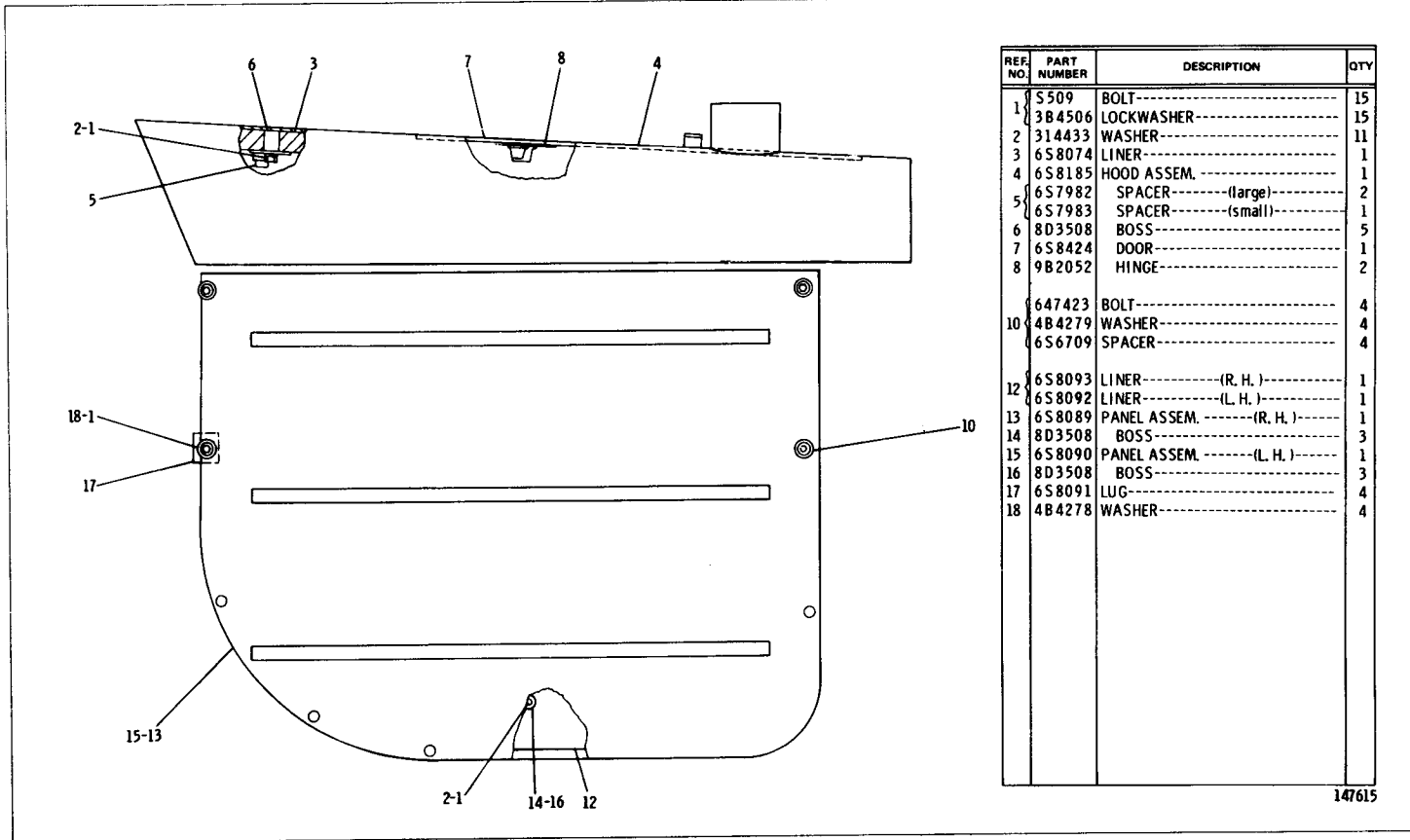

6S8169 HOOD AND GUARD GROUP

Part of 6S8500 Noise Suppression Arrangement listed on Page 88A



6S8169 HOOD AND GUARD GROUP—Type 2—Replaced by 6S9699 shown on Page 54B-2  
 Part of 6S8500 Sound Suppression Arrangement listed on Page 88A  
 AN ATTACHMENT

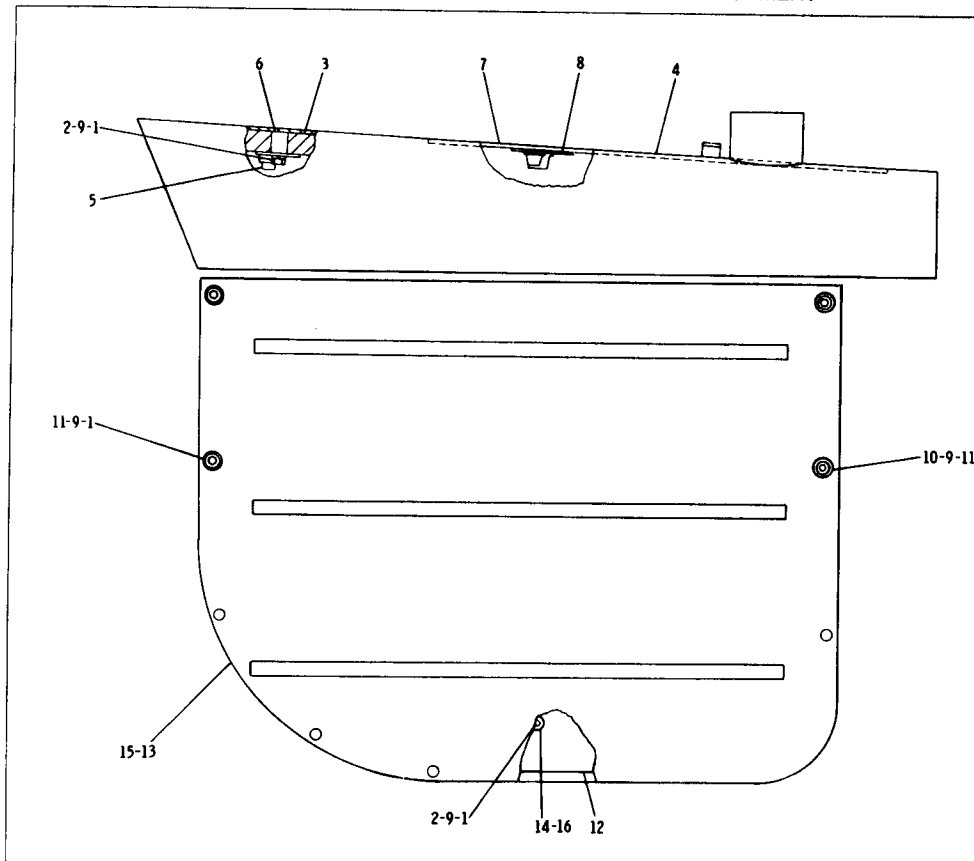

REF. NO.	PART NUMBER	DESCRIPTION	QTY
1	5509	BOLT-----	15
2	314433	WASHER-----	11
3	6S8074	LINER-----	1
4	6S8185	HOOD ASSEM.-----	1
		(Includes)	
5	6S7982	SPACER--50 mm(1.97 in.) thick	2
	6S7983	SPACER--42 mm(1.65 in.) thick	1
6	8D3508	BOSS-----	5
7	6S8424	DOOR-----	1
8	9B2052	HINGE-----	2
9	3B4506	LOCKWASHER-----	19
	51594	BOLT-----	4
C 10	6S6709	WASHER--5.00 mm(.197 in.) thick	4
	2N1440	SPACER--5.94 mm(.234 in.) thick	4
C 11	4B4278	WASHER-1.588 mm(.0625 in.) thick	8
12	6S8093	LINER----- (R. H.)-----	1
	6S8092	LINER----- (L. H.)-----	1
13	6S8089	PANEL ASSEM.----- (R. H.)-----	1
		(Includes)	
14	8D3508	BOSS-----	3
15	6S8090	PANEL ASSEM.----- (L. H.)-----	1
		(Includes)	
16	8D3508	BOSS-----	3

C INDICATES CHANGE

153877

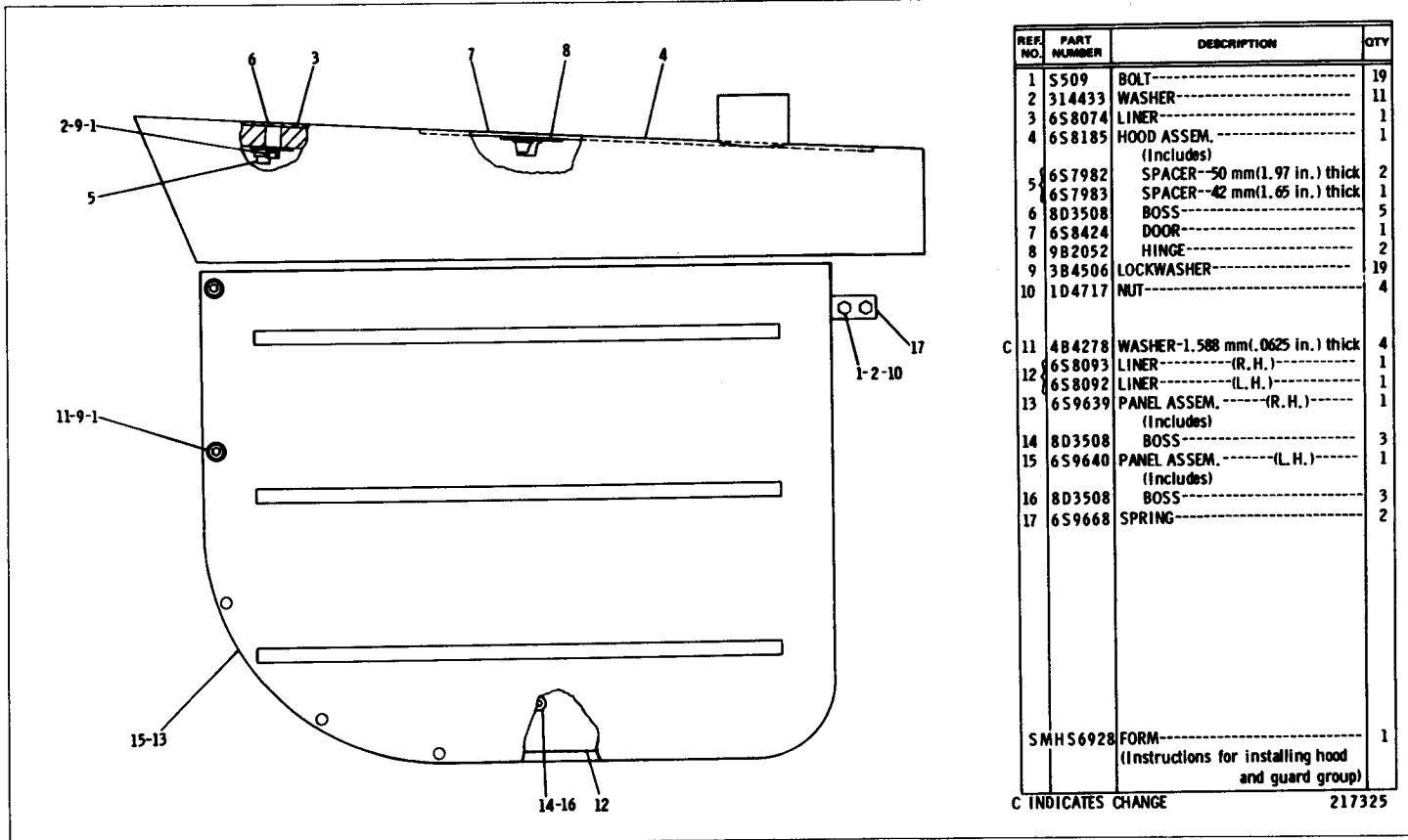

REF. NO.	PART NUMBER	DESCRIPTION	QTY
1	5509	BOLT-----	19
2	314433	WASHER-----	11
3	6S8074	LINER-----	1
4	6S8185	HOOD ASSEM. (Includes)	1
5	6S7982	SPACER--50 mm(1.97 in.) thick	2
6	6S7983	SPACER--42 mm(1.65 in.) thick	1
6	8D3508	BOSS-----	5
7	6S8424	DOOR-----	2
8	982052	HINGE-----	1
9	3B4506	LOCKWASHER-----	19
10	1D4717	NUT-----	4
C 11	4B4278	WASHER-1.588 mm(.0625 in.) thick	4
12	6S8093	LINER----- (R.H.)-----	1
12	6S8092	LINER----- (L.H.)-----	1
13	6S9639	PANEL ASSEM.----- (R.H.)----- (Includes)	1
14	8D3508	BOSS-----	3
15	6S9640	PANEL ASSEM.----- (L.H.)----- (Includes)	1
16	8D3508	BOSS-----	3
17	6S9668	SPRING-----	2
	SMH56928	FORM----- (Instructions for installing hood and guard group)	1

C INDICATES CHANGE

217325

6S9699 HOOD AND GUARD GROUP—Type 1  
Part of 6S8500 Sound Suppression Arrangement listed on Page 88A  
AN ATTACHMENT

6S9699 HOOD AND GUARD GROUP—Type 2  
 Part of 6S8500 Sound Suppression Arrangement listed on Page 88A  
 AN ATTACHMENT

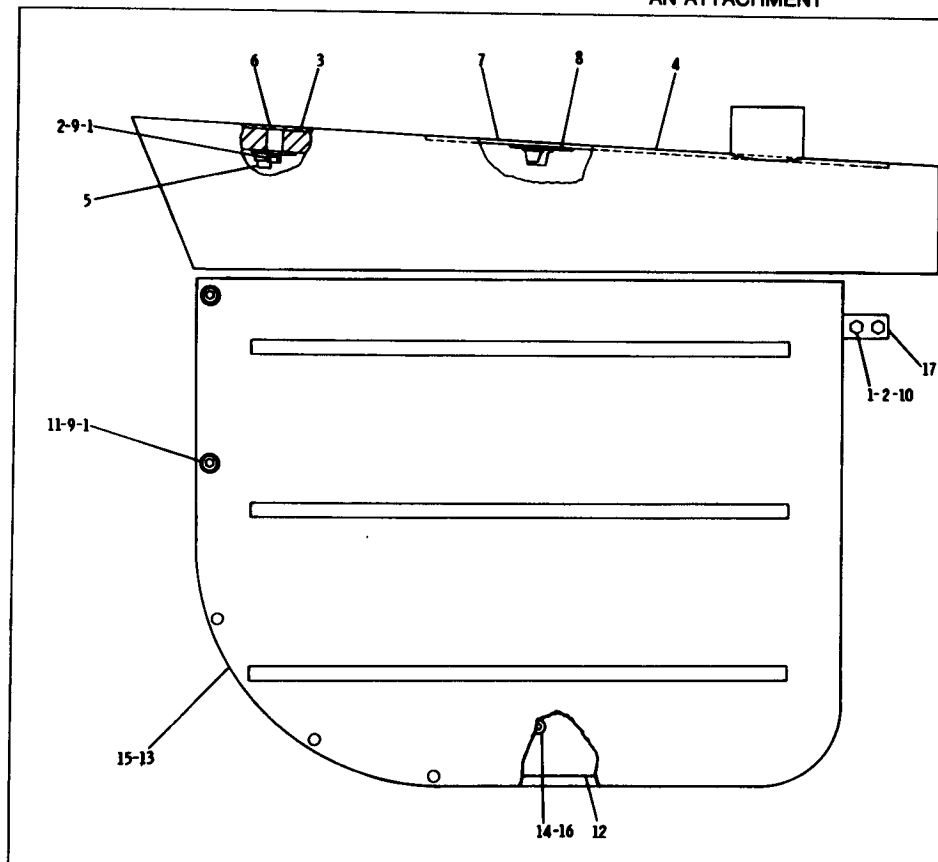

REF. NO.	PART NUMBER	DESCRIPTION	QTY
1	5509	BOLT-----	19
2	314433	WASHER-----	11
3	6S8074	LINER-----	1
4	6S8185	HOOD ASSEM.----- (Includes)	1
5	6S7982	SPACER--50 mm(1.97 in.) thick	2
	6S7983	SPACER--42 mm(1.65 in.) thick	1
6	8D3508	BOSS-----	5
7	6S8424	DOOR-----	1
8	9B2052	HINGE-----	2
9	3B4506	LOCKWASHER-----	19
10	1D4717	NUT-----	4
11	4B4278	WASHER-1.588 mm(.0625 in.) thick	4
12	6S8093	LINER----- (R.H.)	1
C 12	5G1446	LINER----- (L.H.)	1
13	6S9639	PANEL ASSEM.----- (R.H.) (Includes)	1
14	8D3508	BOSS-----	3
C 15	5G1335	PANEL ASSEM.----- (L.H.) (Includes)	1
16	8D3508	BOSS-----	3
17	6S9668	SPRING-----	2
	SMHS692B	FORM----- (Instructions for installing hood and guard group)	1

C INDICATES CHANGE

220215

CHASSIS AND UNDERCARRIAGE

54B-3

HOOD AND GUARD (6S3511 N/S)  
Serial No. 79U1 to 79U834 inclusive

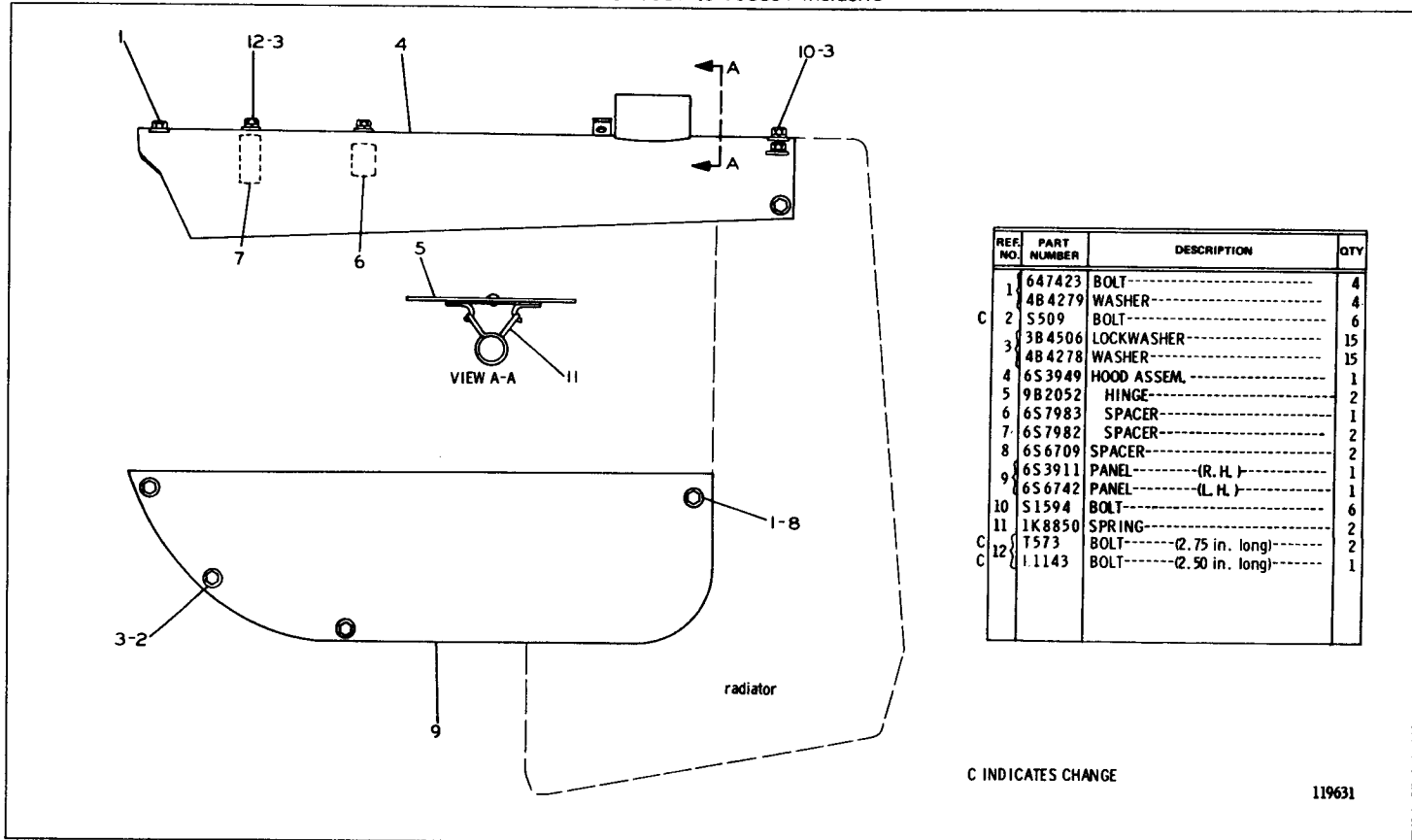

REF. NO.	PART NUMBER	DESCRIPTION	QTY
1	647423	BOLT-----	4
	484279	WASHER-----	4
2	5509	BOLT-----	6
3	3B4506	LOCKWASHER-----	15
	4B4278	WASHER-----	15
4	6S3949	HOOD ASSEM.-----	1
5	9B2052	HINGE-----	2
6	6S7983	SPACER-----	1
7	6S7982	SPACER-----	2
8	6S6709	SPACER-----	2
9	6S3911	PANEL----- (R. H.)	1
	6S6742	PANEL----- (L. H.)	1
10	S1594	BOLT-----	6
11	1K8850	SPRING-----	2
C	7573	BOLT----- (2.75 in. long)	2
C	11143	BOLT----- (2.50 in. long)	1

C INDICATES CHANGE

119631

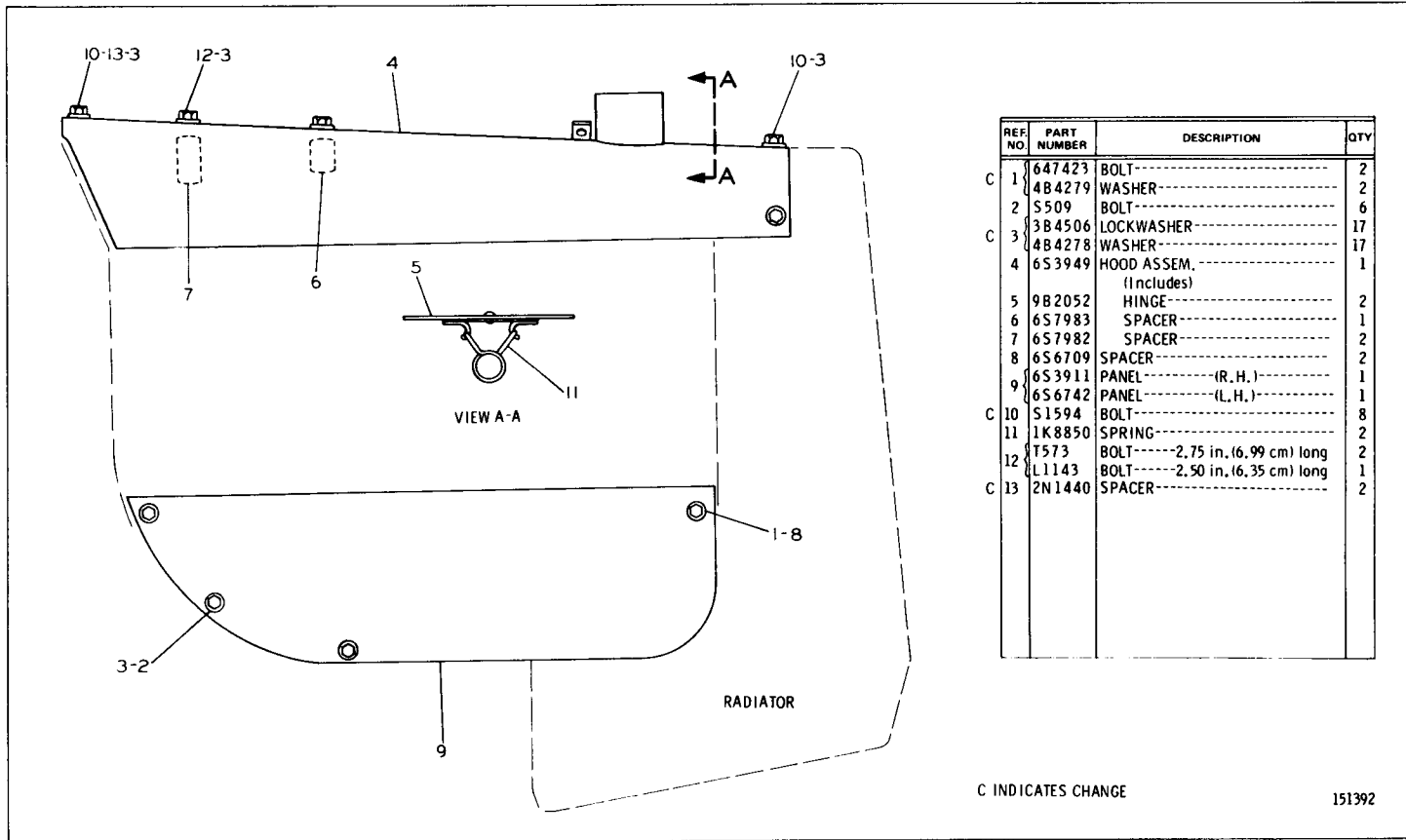

6S3511 HOOD AND GUARD GROUP  
Serial No. 79U835 to 79U1595 inclusive

6S3511 HOOD AND GUARD GROUP  
 Serial No. 79U1596 to 79U4505 inclusive

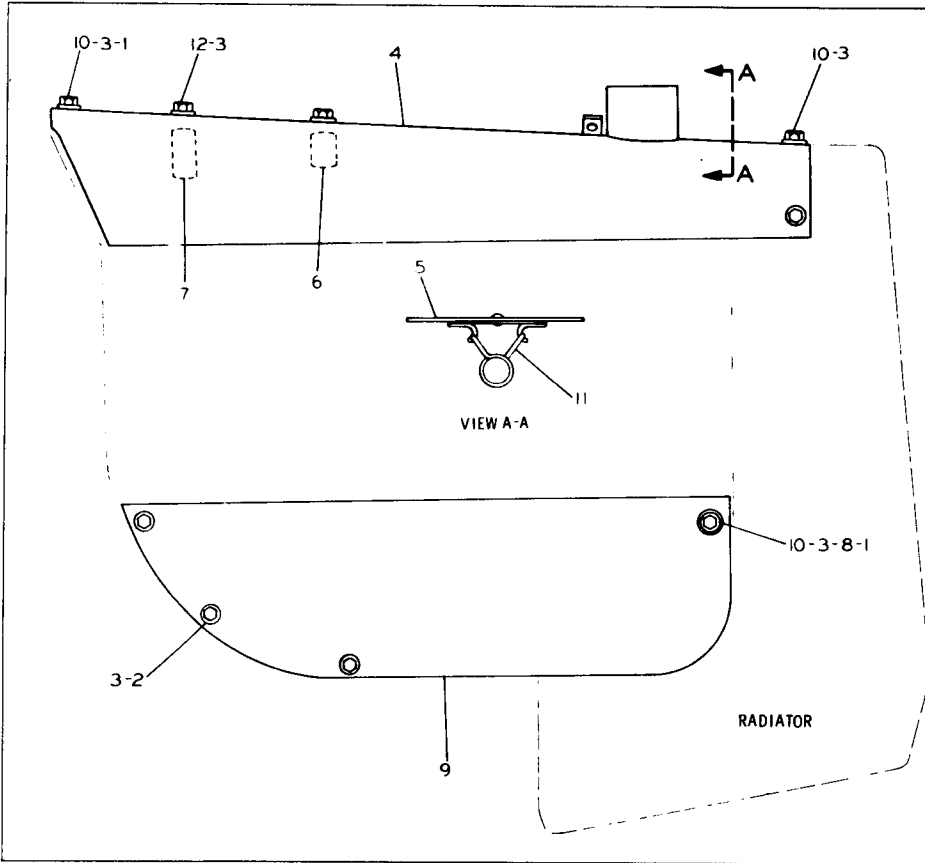

REF NO	PART NUMBER	DESCRIPTION	QTY
C 1	2N1440	SPACER----- .234 in. (5.94 mm) thick	4
2	5509	BOLT-----	6
3	84506	LOCKWASHER-----	19
C 3	4B4278	WASHER----- .0625 in. (1.59 mm) thick	19
4	6S3949	HOOD ASSEM.----- (Includes)	1
5	9B2052	HINGE-----	2
6	6S7983	SPACER-----	1
7	6S7982	SPACER-----	2
8	6S6709	WASHER----- .197 in. (5.00 mm) thick	2
9	6S3911	PANEL----- (R. H.)	1
8	6S6742	PANEL----- (L. H.)	1
C 10	S1594	BOLT-----	10
11	1K8850	SPRING-----	2
12	T573	BOLT-----2.75 in. (6.99 cm) long	2
	L1143	BOLT-----2.50 in. (6.35 cm) long	1

C INDICATES CHANGE

169221

CHASSIS AND UNDERCARRIAGE

6S3511 HOOD AND GUARD GROUP  
Serial No. 79U4506—Up

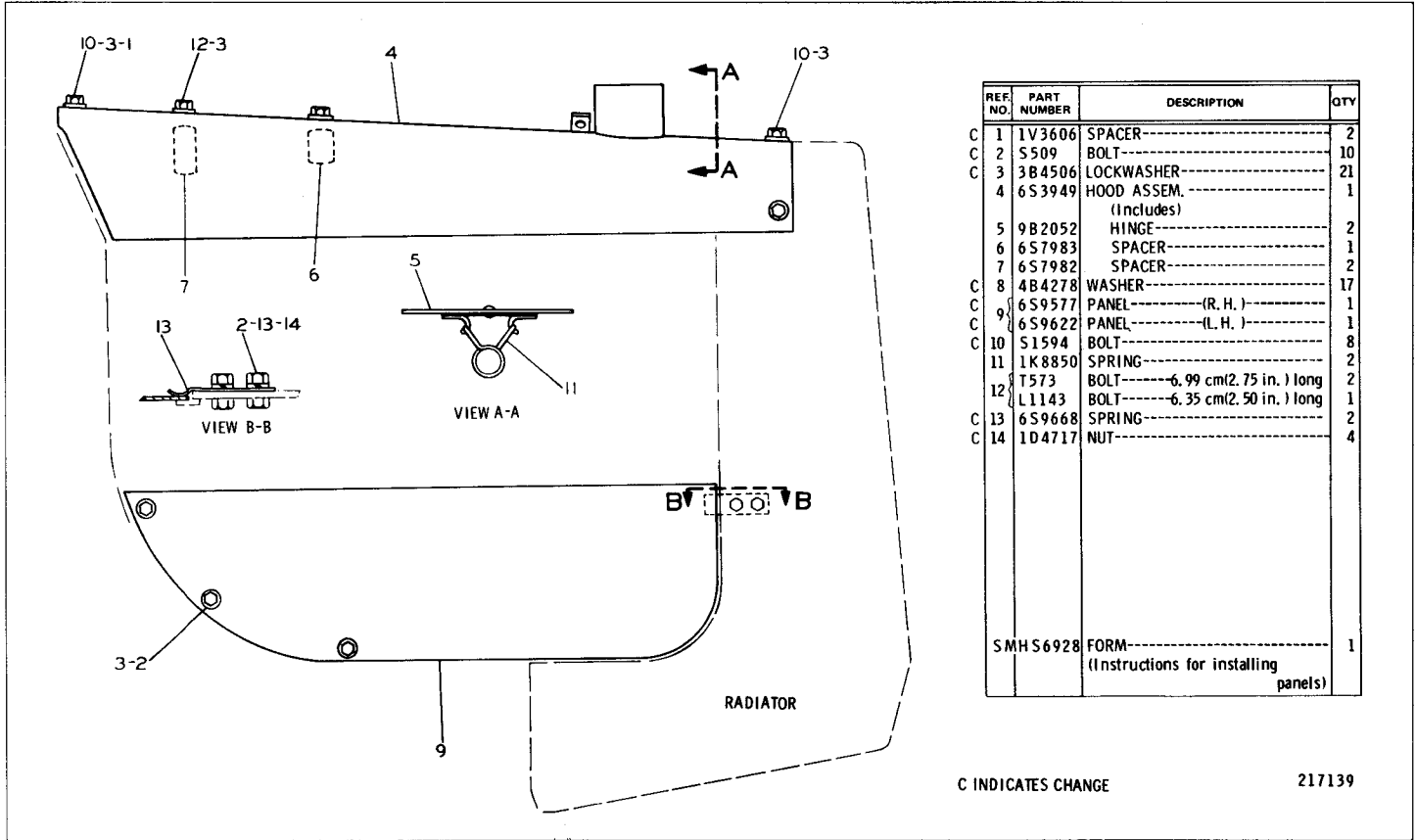

REF. NO.	PART NUMBER	DESCRIPTION	QTY
C 1	1V3606	SPACER-----	2
C 2	5509	BOLT-----	10
C 3	3B4506	LOCKWASHER-----	21
C 4	6S3949	HOOD ASSEM.----- (Includes)	1
5	9B2052	HINGE-----	2
6	6S7983	SPACER-----	1
7	6S7982	SPACER-----	2
C 8	4B4278	WASHER-----	17
C 9	6S9577	PANEL----- (R. H.)	1
C 9	6S9622	PANEL----- (L. H.)	1
C 10	S1594	BOLT-----	8
11	1K8850	SPRING-----	2
12	T573	BOLT-----6.99 cm(2.75 in.) long	2
12	L1143	BOLT-----6.35 cm(2.50 in.) long	1
C 13	6S9668	SPRING-----	2
C 14	1D4717	NUT-----	4
	SMHS6928	FORM----- (Instructions for installing panels)	1

C INDICATES CHANGE

217139

CHASSIS AND UNDERCARRIAGE

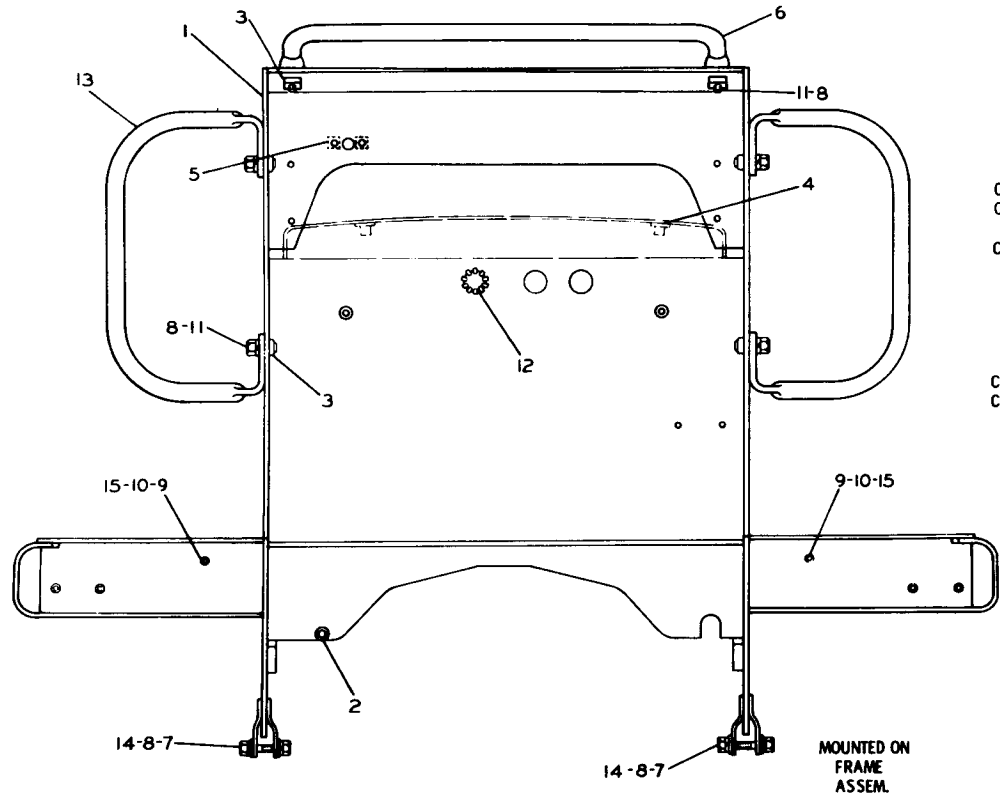

REF. NO.	PART NUMBER	DESCRIPTION	QTY
1	6S4415	FIREWALL ASSEM.-----	1
2	4D9376	BOSS-----	5
3	1F748	NUT-----	6
C 4	9F2978	NUT-----	2
C 5	9F6445	NUT-----	4
6	6S4397	GRAB IRON-----	1
C 7	6H1717	BOLT-----	4
8	3B4508	LOCKWASHER-----	10
9	S1594	BOLT-----	6
10	3B4506	LOCKWASHER-----	6
11	S1595	BOLT-----	6
12	4S6336	PLUG-----	1
13	6S8011	GRAB IRON-----	2
C 14	4B4280	WASHER-----	4
C 15	4B4278	WASHER-----	6

C INDICATES CHANGE

217173

6S3407 FIREWALL GROUP



6S3605 UNDERCARRIAGE SUPPORT GROUP

Serial No. 79U1 to 79U4166, 4169 to 4215, 4217 to 4232, 4264, 4267, 4295, 4296, 4299, 4324 and 79U4328 inclusive

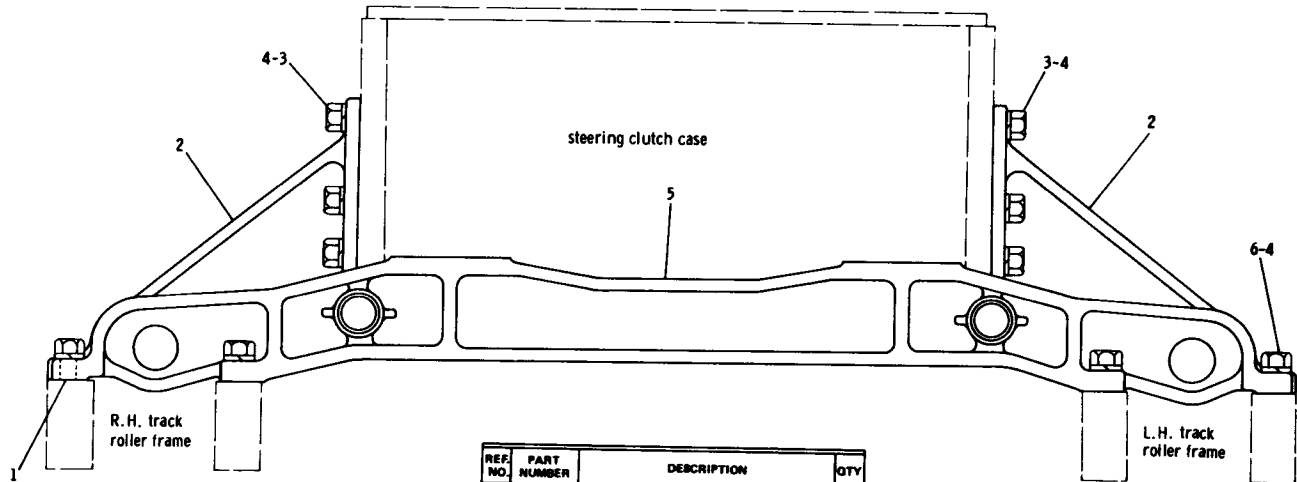

REF. NO.	PART NUMBER	DESCRIPTION	QTY
1	6K8987	DOWEL-----	4
2	6S3714	SUPPORT----- (Mounted on Steering Clutch Case)	2
3	L1178	BOLT-----	16
4	3H4512	LOCKWASHER-----	36
C 5	6S3625	SUPPORT-----	1
6	1A8063	BOLT-----	20

C INDICATES CHANGE

145369

5G378 UNDERCARRIAGE SUPPORT GROUP  
 Serial No. 79U4167, 4168, 4216, 4233 to 4263, 4265, 4266, 4268 to 4294, 4297,  
 4298, 4300 to 4323, 4325 to 4327 and 79U4329—Up

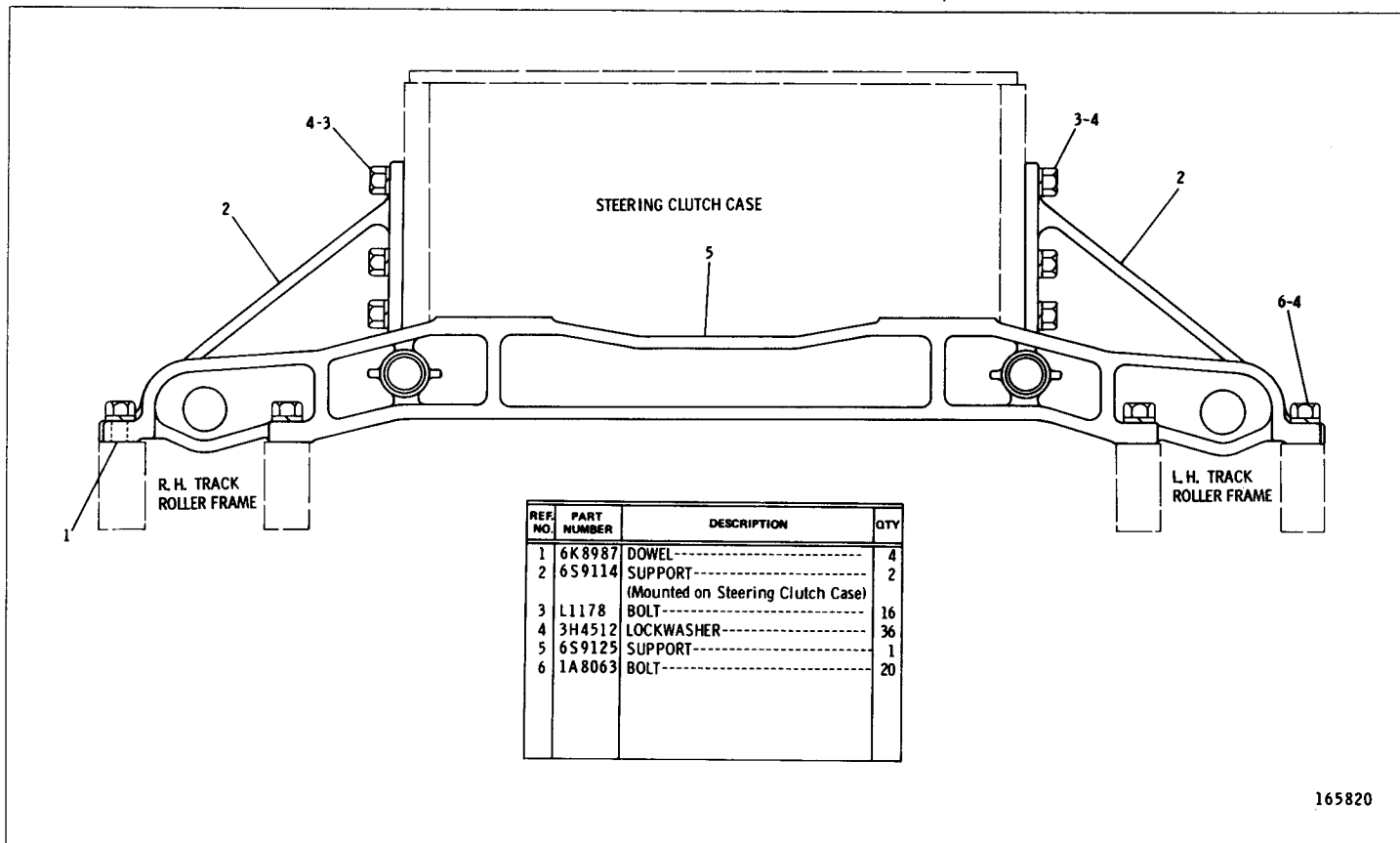

REF. NO.	PART NUMBER	DESCRIPTION	QTY
1	6K 8987	DOWEL-----	4
2	6S 9114	SUPPORT----- (Mounted on Steering Clutch Case)	2
3	L1178	BOLT-----	16
4	3H4512	LOCKWASHER-----	36
5	6S 9125	SUPPORT-----	1
6	1A 8063	BOLT-----	20

165820

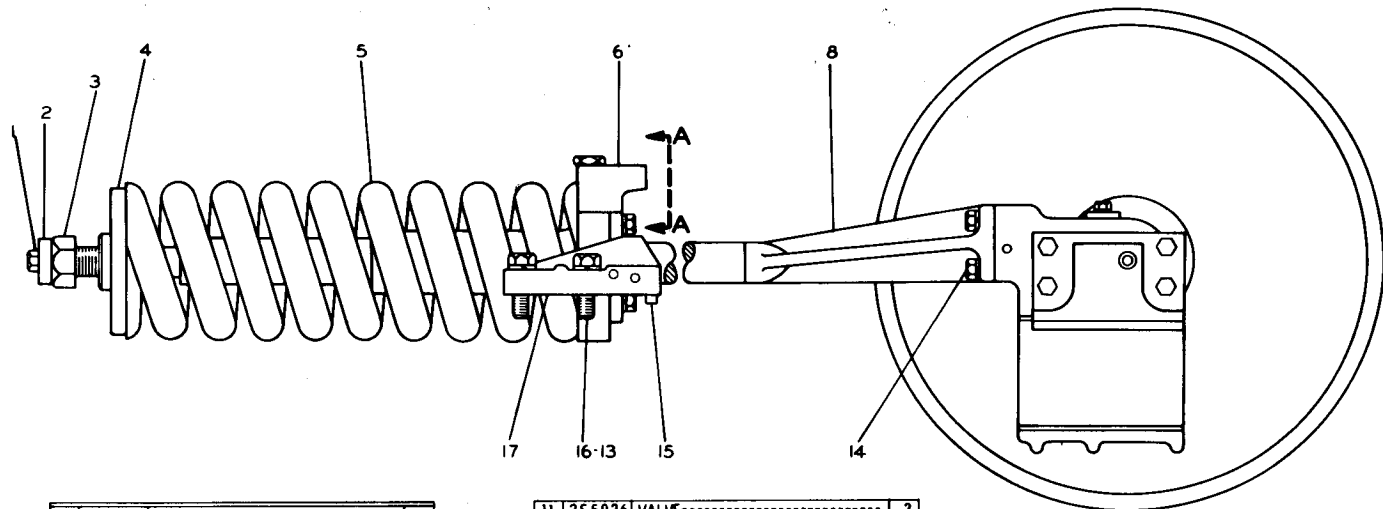

REF NO	PART NUMBER	DESCRIPTION	QTY
1	51595	BOLT-----	2
2	181067	WASHER-----	2
3	184210	NUT-----	2
4	5K1686	SEAT-----	2
5	6S3363	SPRING-----	2
C 6	6S8952	HEAD GROUP-----	2
7	2S5927	PLATE----- (warning)	1
7	7B3028	SCREW-----	4
8	6S3275	YOKE ASSEM.-----	2
9	2S5925	VALVE-----	2
10	5M6708	WASHER-----	4

11	2S5926	VALVE-----	2
12	51566	BOLT-----	8
13	3B4510	LOCKWASHER-----	16
14	51585	BOLT-----	8
14	3B4508	LOCKWASHER-----	8
C 15	9H4105	DOWEL-----	4
16	8S9092	BOLT-----	8
	1M5391	STOP-----	2
		(R.H. Outer-L.H. Inner)	
17	1M5392	STOP-----	2
		(R.H. Inner-L.H. Outer)	

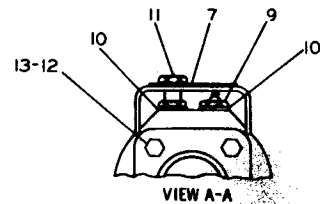

C INDICATES CHANGE

207757

## 6S3610 FRONT IDLER GROUP—Part 1

Serial No. 79U1 to 79U4077 inclusive

Note: Quantities shown are those required for both R.H. &amp; L.H. sides

6S3610 FRONT IDLER GROUP—Part 2

Serial No. 79U1 to 79U4077 inclusive

Note: Quantities shown are those required for both R.H. and L.H. sides

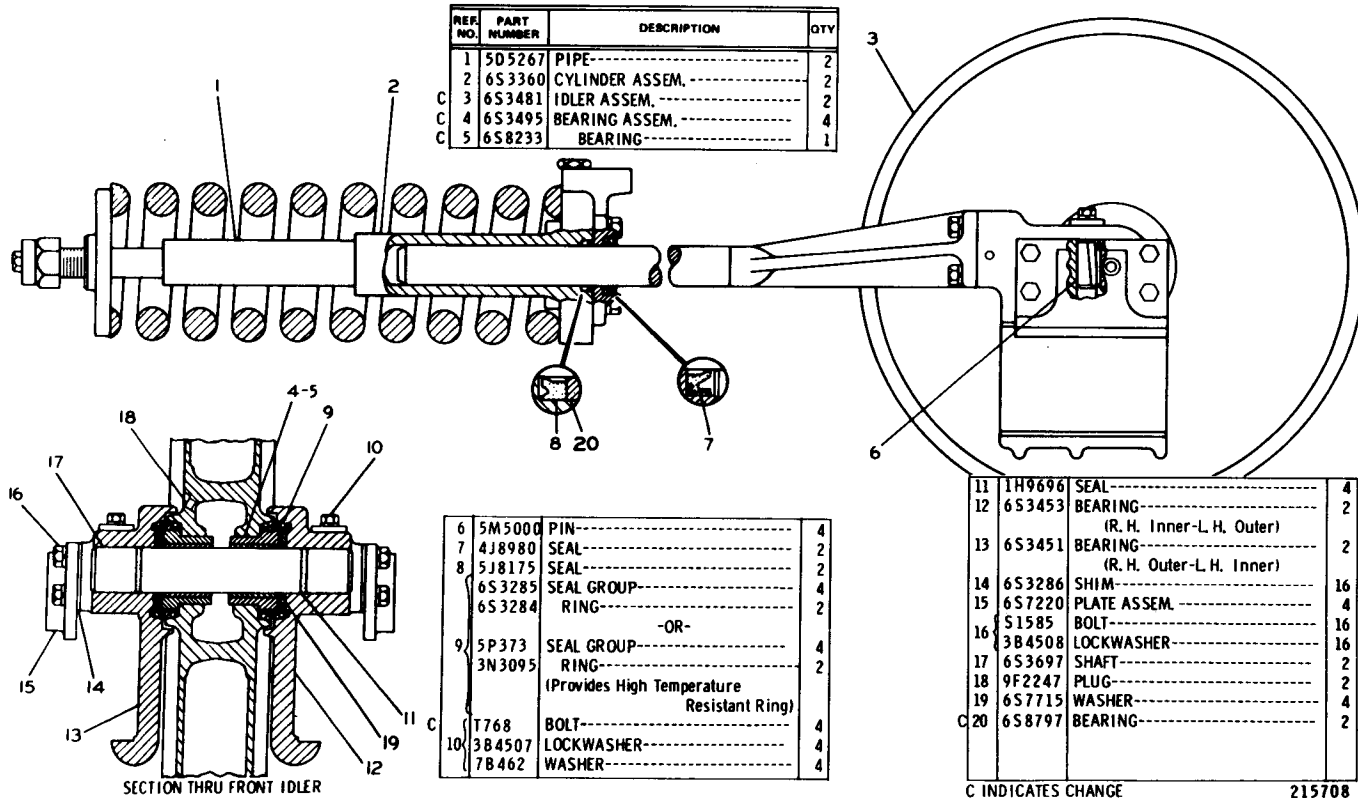

C INDICATES CHANGE

215708

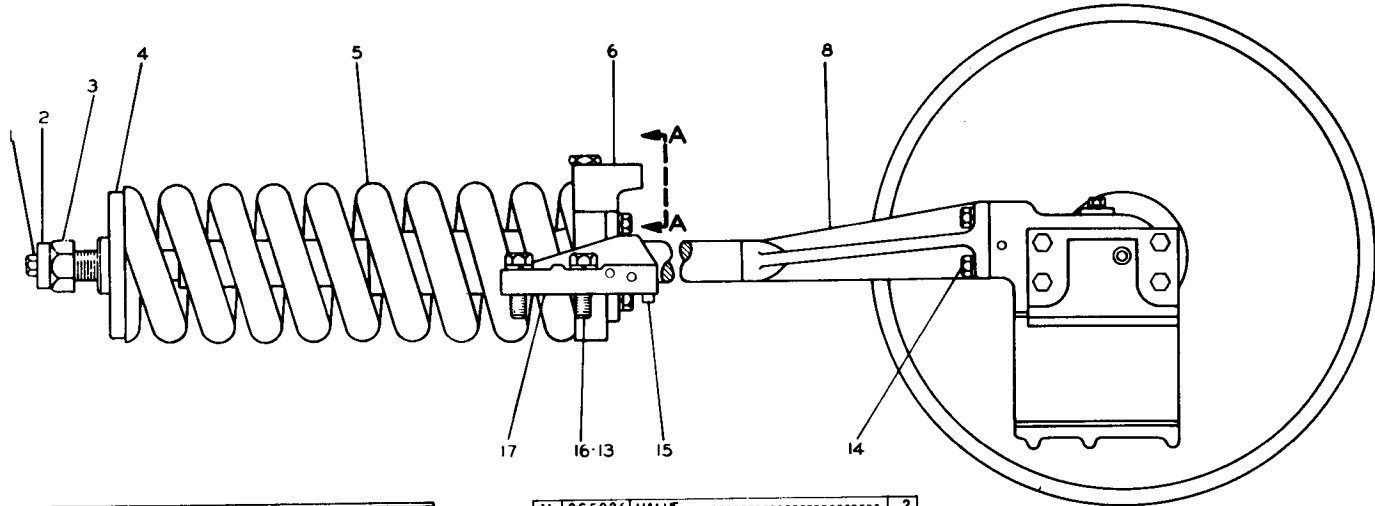

REF. NO.	PART NUMBER	DESCRIPTION	QTY
1	S 1595	BOLT-----	2
2	1B 1067	WASHER-----	2
3	1B 4210	NUT-----	2
C 4	2V9025	PILOT-----	2
5	6S3363	SPRING-----	2
6	6S8952	HEAD GROUP-----	2
C 7	5P9446	PLATE-----(-warning)-	1
7	7B3028	SCREW-----	4
8	6S3275	YOKE ASSEM.-----	2
9	2S5925	VALVE-----	2
10	5M6708	WASHER-----	4

11	2S5926	VALVE-----	2
12	S 1566	BOLT-----	8
13	3B4510	LOCKWASHER-----	16
14	S 1585	BOLT-----	8
14	3B4508	LOCKWASHER-----	8
15	9H4105	DOWEL-----	4
16	8S9092	BOLT-----	8
C 16	2V7524	STOP-----	2
		(R.H. Outer-L.H. Inner)	
C 17	2V7525	STOP-----	2
		(R.H. Inner-L.H. Outer)	

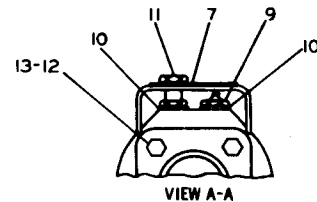

C INDICATES CHANGE

220782

## 6S3610 FRONT IDLER GROUP—Part 1

Serial No. 79U4078—Up

Note: Quantities shown are those required for both R.H. &amp; L.H. sides

6S3610 FRONT IDLER GROUP—Part 2

Serial No. 79U4078—Up

Note: Quantities shown are those required for both R.H. & L.H. sides

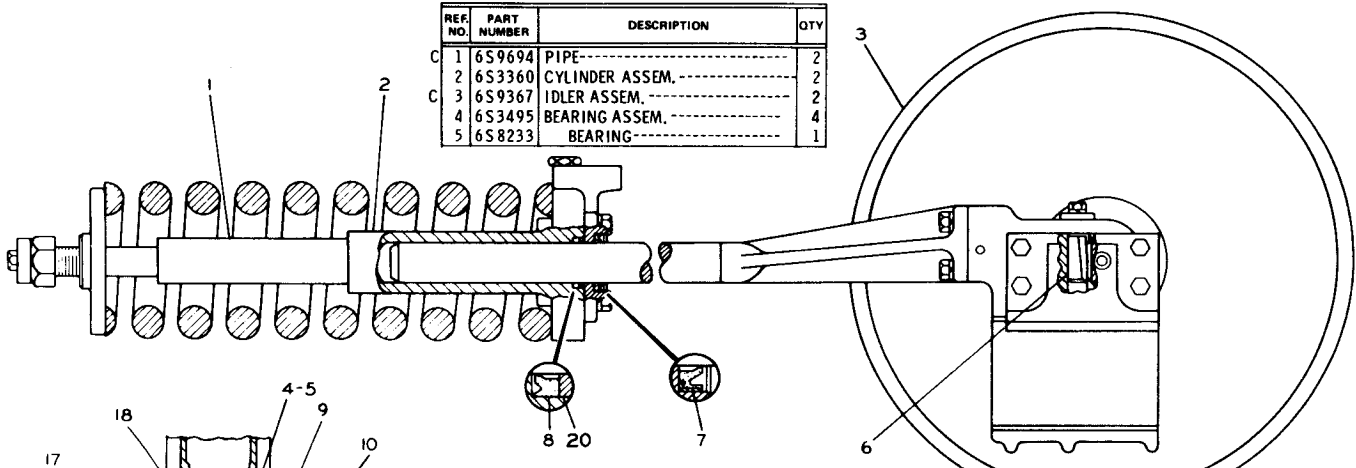

REF. NO.	PART NUMBER	DESCRIPTION	QTY
C 1	6S9694	PIPE-----	2
2	6S3360	CYLINDER ASSEM.-----	2
C 3	6S9367	IDLER ASSEM.-----	2
4	6S3495	BEARING ASSEM.-----	4
5	6S8233	BEARING-----	1

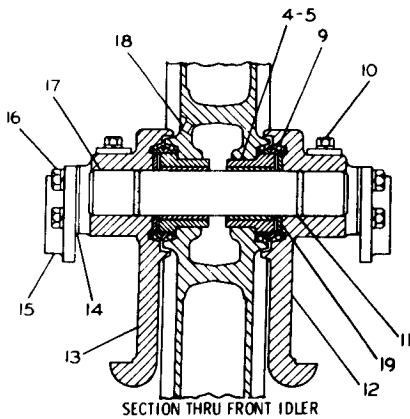

6	5M5000	PIN-----	4
7	4J8980	SEAL-----	2
8	5J8175	SEAL-----	2
9	6S3285	SEAL GROUP---- ( STANDARD ) ----	4
10	6S3284	RING-----	2
-OR-			
9	5P373	SEAL GROUP-----	4
9	3N3095	RING-----	2
(Provides High Temperature Resistant Ring)			
11	7768	BOLT-----	4
10	3B4507	LOCKWASHER-----	4
10	7B462	WASHER-----	4

▲ NOT PART OF 6S3610 FRONT IDLER GROUP.

11	1H9696	SEAL-----	4
12	6S3453	BEARING-----	2
(R. H. Inner-L. H. Outer)			
13	6S3451	BEARING-----	2
(R. H. Outer-L. H. Inner)			
14	6S3286	SHIM-----	16
15	6S7220	PLATE ASSEM.-----	4
16	S1585	BOLT-----	16
16	3B4508	LOCKWASHER-----	16
17	6S3697	SHAFT-----	2
18	9F2247	PLUG-----	2
19	6S7715	WASHER-----	4
20	6S8797	BEARING-----	2

C INDICATES CHANGE

217154

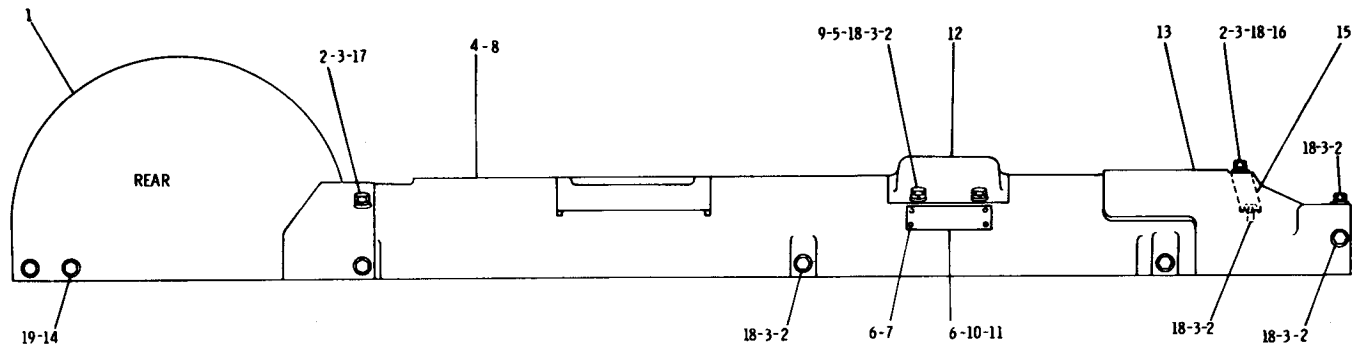

REF. NO.	PART NUMBER	DESCRIPTION	QTY
C 1	6S6670	GUARD ASSEM. ----(R. H.)----	1
C 2	6S6746	GUARD ASSEM. ----(L. H.)----	1
C 3	L1351	BOLT-----	32
C 3	3B4506	LOCKWASHER-----	32
C 4	6S6756	GUARD ASSEM. ----(R. H.)----	1
		(Includes)	
	5 9F2978	NUT-----	3
	6 1S5242	PLATE-----	1
	7 7B3028	SCREW-----	4

C 8	6S6755	GUARD ASSEM. ----(L. H.)----	1
		(Includes)	
	9 9F2978	NUT-----	3
	10 1S5242	PLATE-----	1
	11 7B3028	SCREW-----	4
	12 6S3747	COVER-----	2
	13 6S3799	COVER----- (R. H.)----	1
	13 6S3800	COVER----- (L. H.)----	1
C 14	S1621	BOLT-----	4
15	6S6741	BRACKET ASSEM. ----	2
		(Includes)	
	16 9F2978	NUT-----	1

C 17	3F1417	WASHER-----	4
C 18	4B4278	WASHER-----	28
C 19	7F502	WASHER-----	4
C	3B4508	LOCKWASHER-----	4

C INDICATES CHANGE

165543

## 6S3606 RECOIL MECHANISM GUARD GROUP

Serial No. 79U1 to 79U4166, 4169 to 4215, 4217 to 4232, 4264, 4267, 4295, 4296, 4299, 4324 and 79U4328 inclusive

Note: Quantities shown are those required for both R.H. &amp; L.H. sides

6S9045 RECOIL MECHANISM GUARD GROUP  
 Serial No. 79U4167, 4168, 4216, 4233 to 4263, 4265, 4266, 4268 to 4294, 4297, 4298,  
 4300 to 4323, 4325 to 4327 and 79U4329—Up. Note: Quantities shown are those  
 required for both R.H. & L.H. sides

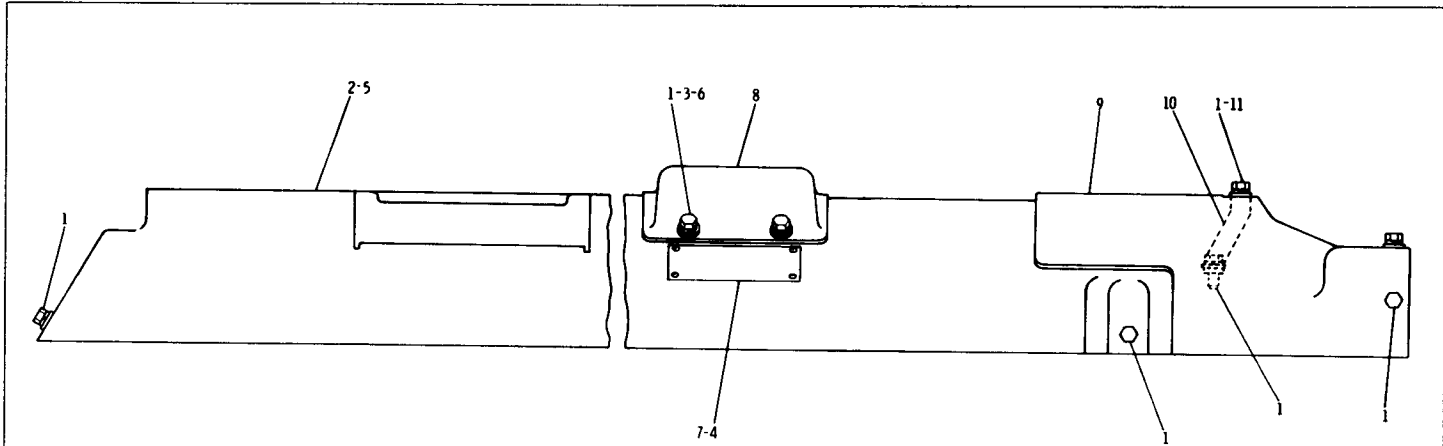

REF NO	PART NUMBER	DESCRIPTION	QTY
	11351	BOLT-----	30
1	3B4506	LOCKWASHER-----	30
	4B4278	WASHER-----	30
C 2	5G1802	GUARD ASSEM. -----(R. H.)-----	1
		(Includes)	
3	9F2978	NUT-----	2
4	5P9441	PLATE----- (warning)-----	1
	7B3028	SCREW-----	4

C 5	5G1803	GUARD ASSEM. -----(L. H.)-----	1
		(Includes)	
6	9F2978	NUT-----	2
	5P9441	PLATE----- (warning)-----	1
7	7B3028	SCREW-----	4
8	6S3747	COVER-----	2
	6S3799	GUARD----- (R. H.)-----	1
9	6S3800	GUARD----- (L. H.)-----	1

10	6S6741	BRACKET ASSEM. -----	2
		(Each Includes)	
11	9F2978	NUT-----	1

C INDICATES CHANGE

220721



REF. NO.	PART NUMBER	DESCRIPTION	QTY
1	1B4264	COLLAR-----	6
2	S1587	BOLT-----	10
3	3B4508	LOCKWASHER-----	14
4	5L4398	BOLT-----	4
4	1D4719	NUT-----	4
5	6S9341	PLATE-----	2
6	1J8930	BOLT-----	2
6	3B4512	LOCKWASHER-----	4
7	4B5276	WASHER-----	4

8	5G439	BRACKET ASSEM. -----(R. H.)----	1
8	5G440	BRACKET ASSEM. -----(L. H.)----	1
		(Each Includes)	
	9F2978	NUT-----	2
9	1D4616	BOLT-----	2
10	6S9342	PLATE-----	8
11	L1351	BOLT-----	2
12	6S9347	GUARD-----	1
13	3B4506	LOCKWASHER-----	6
14	4B4278	WASHER-----	2
15	5G425	PLATE-----	1
16	5G436	COVER-----	1
17	S1588	BOLT-----	4

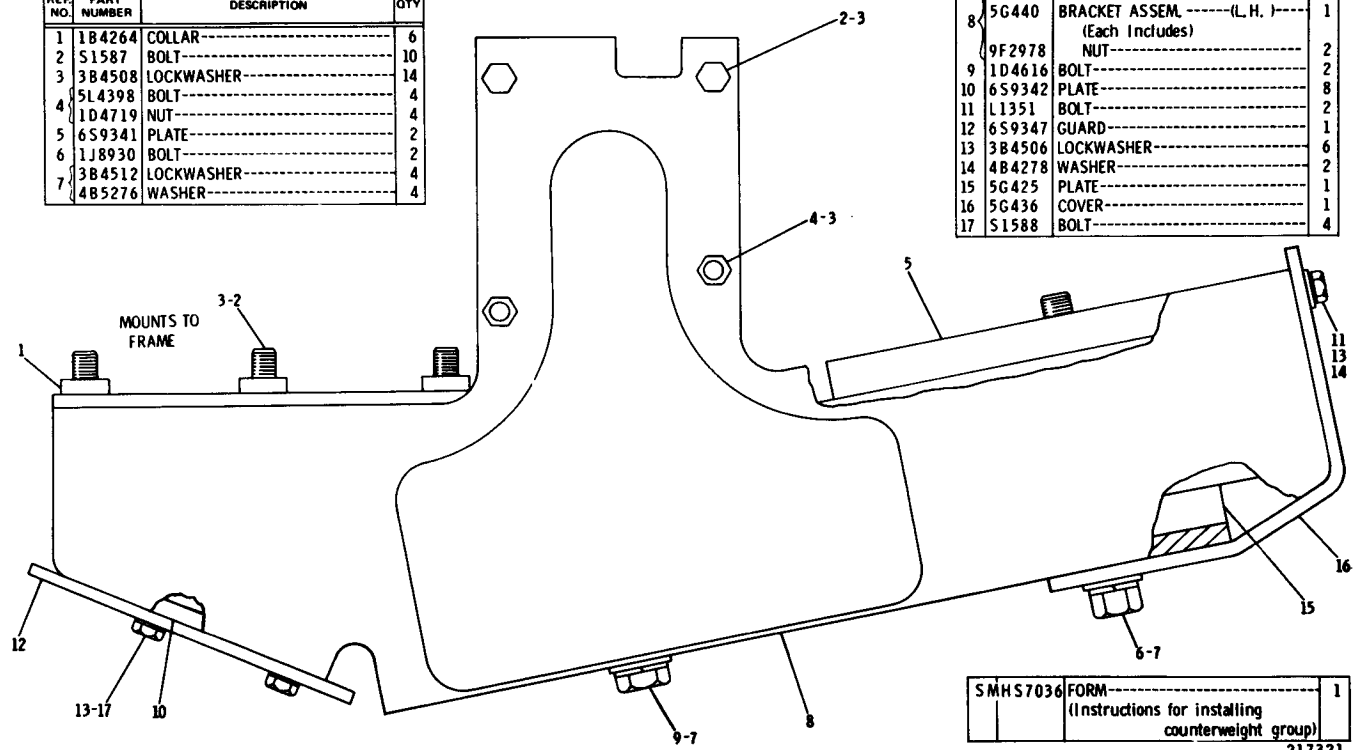

SMHS7036	FORM-----	1
	(Instructions for installing counterweight group)	

217321

5G441 FRONT COUNTERWEIGHT GROUP  
 CANNOT BE USED WITH 6S3864 FRONT PULL HOOK GROUP SHOWN ON Page 54  
 AN ATTACHMENT

6S9356 FRONT COUNTERWEIGHT GROUP—Replaced by 5G441 shown on Page 60-2  
AN ATTACHMENT

REF. NO.	PART NUMBER	DESCRIPTION	QTY
1	1B4264	COLLAR-----	6
2	S1587	BOLT-----	10
3	3B4508	LOCKWASHER-----	14
	1H2415	BOLT-----	4
4	1D4719	NUT-----	4
	4F6454	SLEEVE-----	4
5	6S9341	PLATE-----	2
6	1D4620	BOLT-----	2
7	3B4512	LOCKWASHER-----	4
	4B5276	WASHER-----	4

8	6S9354	BRACKET ASSEM. ----(R. H.)----	1
	6S9353	BRACKET ASSEM. ----(L. H.)----	1
9	1D4616	BOLT-----	2
10	6S9342	PLATE-----	9
	L1351	BOLT-----	4
11	3B4506	LOCKWASHER-----	4
12	6S9347	GUARD-----	1

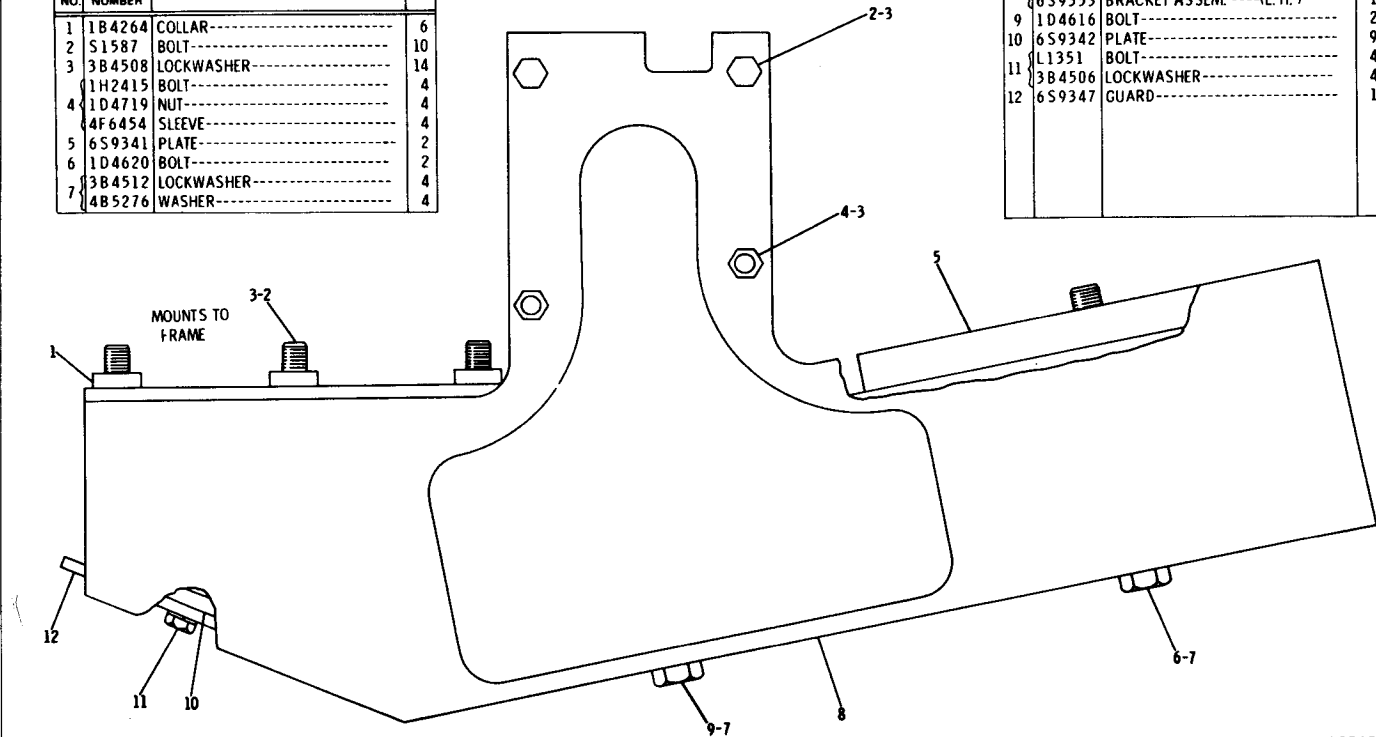

## CATERPILLAR D3 TRACTOR

## CONSISTS OF:

2 6S9374 IDLER ASSEMBLY

## EACH CONSISTING OF:

1 6S9367 IDLER ASSEMBLY

2 6S3495 BEARING ASSEMBLY

## EACH CONSISTING OF:

1 6S8233 BEARING

**6S9384 FRONT IDLER GROUP—Large O.D.  
AN ATTACHMENT**

## CONSISTS OF:

2 6S3495 BEARING ASSEMBLY

## EACH CONSISTING OF:

1 6S8233 BEARING

1 5G238 IDLER ASSEMBLY

**5G363 COUNTERWEIGHT IDLER ASSEMBLY**

Provides Counterweighted front idlers to improve vehicle stability when equipped with a backhoe, 3 LGP Bulldozer, ROPS and rear mounted attachment. CANNOT BE USED WITH MULTI-PURPOSE BUCKET. AN ATTACHMENT

CONSISTS OF:

2 6S3495 BEARING ASSEMBLY

EACH CONSISTING OF:

1 6S8233 BEARING

1 6S8554 IDLER ASSEMBLY

**6S8559 IDLER ASSEMBLY—Replaced by 5G363 Counterweight Idler Assembly**  
 Provides Counterweighted front idlers to improve vehicle stability when equipped with a backhoe, 3 LGP Bulldozer, ROPS and rear mounted attachment. **CANNOT BE USED WITH MULTI-PURPOSE BUCKET. AN ATTACHMENT**

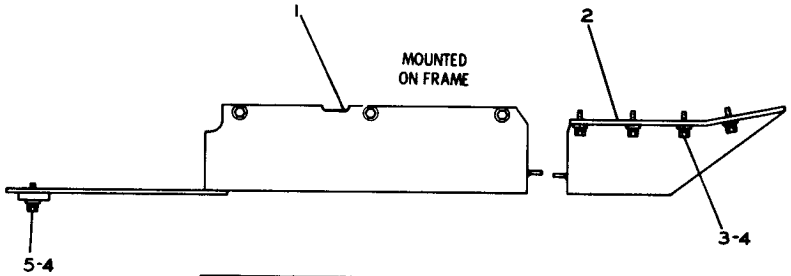

REF. NO.	PART NUMBER	DESCRIPTION	QTY
1	6S4179	GUARD ASSEM.-----	1
2	5G842	GUARD ASSEM.-----	1
C 3	S1595	BOLT-----	14
C 4	384508	LOCKWASHER-----	16
	2M849	WASHER-----	16
C 5	S1585	BOLT-----	2

C INDICATES CHANGE

221157

**6S3513 CRANKCASE GUARD GROUP**  
**AN ATTACHMENT**

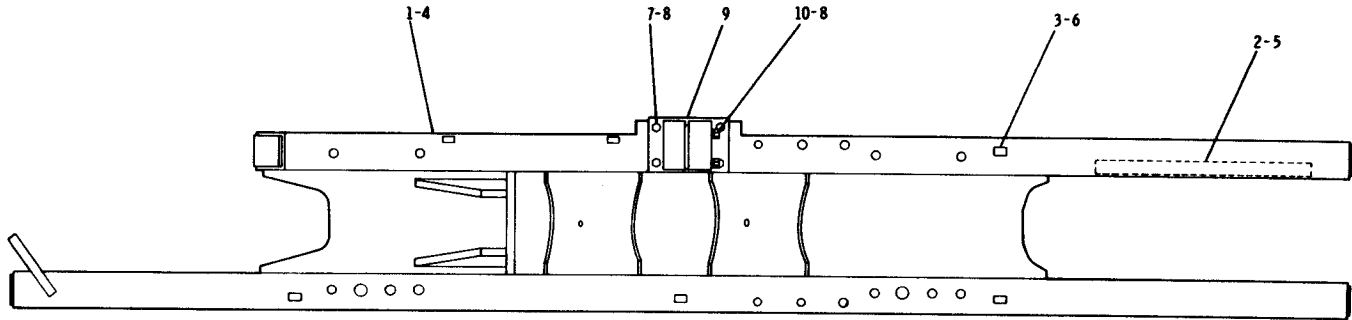

REF. NO.	PART NUMBER	DESCRIPTION	QTY
C 1	6S3810	FRAME ASSEM. -----(L. H.)----- (Includes)	1
C 2	6S3442	STRIP-----	2
C 3	4B5440	PLATE-----	6
C 4	6S3811	FRAME ASSEM. -----(R. H.)----- (Includes)	1
C 5	6S3442	STRIP-----	2
C 6	4B5440	PLATE-----	6

7	7B3235	BOLT-----	8
8	3B4508	LOCKWASHER-----	12
C 9	6S9235	BRACKET ASSEM. -----	2
10	S1623	BOLT-----	4

C INDICATES CHANGE

165821

## 6S3611 TRACK ROLLER FRAME GROUP

Serial No. 79U1 to 4166, 4169 to 4215, 4217 to 4232, 4264, 4267, 4295, 4296, 4299, 4324 and 79U4328 inclusive. Note: Quantities shown are those required for both R.H. & L.H. sides

6S8909 TRACK ROLLER FRAME GROUP

Serial No. 79U4167, 4168, 4216, 4233 to 4263, 4265, 4266, 4268 to 4294, 4297,  
4298, 4300 to 4323, 4325 to 4327 & 79U4329—Up

Note: Quantities shown are those required for both R.H. and L.H. sides

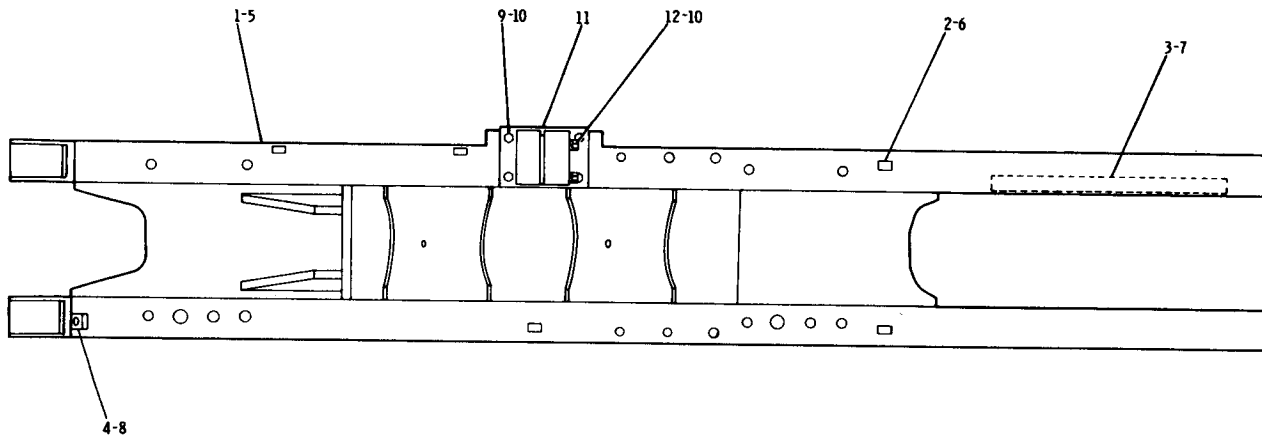

REF NO.	PART NUMBER	DESCRIPTION	QTY
1	6S8468	FRAME ASSEM. -----(R. H.)----- (Includes)	1
2	4B5440	PLATE-----	5
3	6S3442	STRIP-----	2
4	6S9598	PLATE-----	1
5	6S8907	FRAME ASSEM. -----(L. H.)----- (Includes)	1
6	4B5440	PLATE-----	5
7	6S3442	STRIP-----	2
8	6S9598	PLATE-----	1

9	7B3235	BOLT-----	8
10	3B4508	LOCKWASHER-----	12
11	6S9235	BRACKET ASSEM. -----	2
12	51623	BOLT-----	4

165822

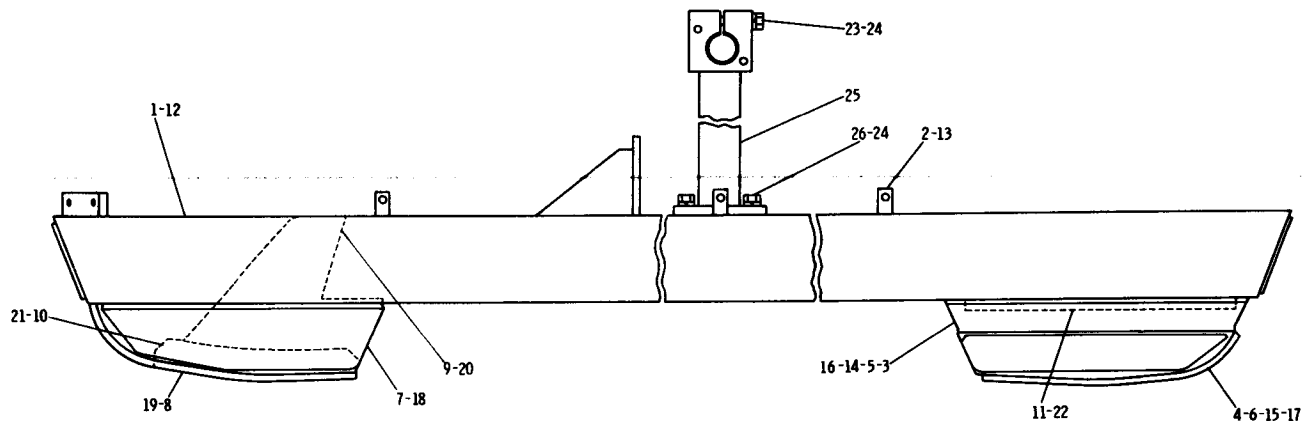

REF. NO.	PART NUMBER	DESCRIPTION	QTY
1	6S7925	FRAME ASSEM.------(R, H.)----- (Includes)	1
2	4B5440	PLATE-----	6
3	6S8412	GUARD ASSEM.----- (Includes)	1
4	6S7843	STRIP-----	1
5	6S8413	GUARD ASSEM.----- (Includes)	1
6	6S7843	STRIP-----	1
7	6S8414	GUARD ASSEM.----- (Includes)	1
8	6S7854	STRIP-----	1
9	6S8415	GUARD ASSEM.----- (Includes)	1
10	6S7853	STRIP-----	1
11	6S3442	STRIP-----	1

12	6S7926	FRAME ASSEM.------(L, H.)----- (Includes)	1
13	4B5440	PLATE-----	6
14	6S8412	GUARD ASSEM.----- (Includes)	1
15	6S7843	STRIP-----	1
16	6S8413	GUARD ASSEM.----- (Includes)	1
17	6S7843	STRIP-----	1
18	6S8416	GUARD ASSEM.----- (Includes)	1
19	6S7854	STRIP-----	1
20	6S8417	GUARD ASSEM.----- (Includes)	1
21	6S7853	STRIP-----	1
22	6S3442	STRIP-----	2

23	S1623	BOLT-----	4
24	3B4508	LOCKWASHER-----	12
25	6S9235	BRACKET ASSEM.-----	2
26	S1585	BOLT-----	8

165830

## 6S7447 TRACK ROLLER FRAME GROUP

Serial No. 79U1 to 4166, 4169 to 4215, 4217 to 4232, 4264, 4267, 4295, 4296, 4324 & 79U4328 inclusive  
AN ATTACHMENT

6S9704 TRACK ROLLER FRAME GROUP  
 Serial No. 79U4167, 4168, 4216, 4233 to 4263, 4265, 4266, 4268 to 4294, 4297,  
 4298, 4300 to 4323, 4325 to 4327 & 79U4329—Up. AN ATTACHMENT

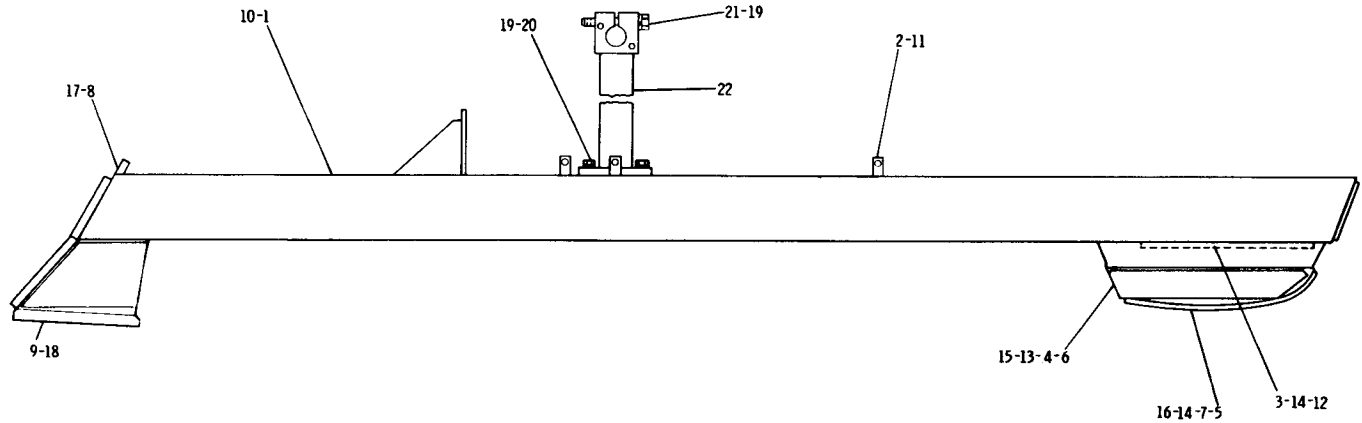

REF. NO.	PART NUMBER	DESCRIPTION	QTY
1	6S9702	FRAME ASSEM. --- (R. H.) --- (Includes)	1
2	4B5440	PLATE-----	5
3	6S3442	STRIP-----	2
4	6S8412	GUARD ASSEM. --(R. H. outer)- (Includes)	1
5	6S7843	STRIP-----	1
6	6S8413	GUARD ASSEM. --(R. H. inner)- (Includes)	1
7	6S7843	STRIP-----	1
8	6S9598	PLATE-----	1
9	6S9696	GUARD ASSEM.-----	1

10	6S9703	FRAME ASSEM. --- (L. H.) --- (Includes)	1
11	4B5440	PLATE-----	5
12	6S3442	STRIP-----	2
13	6S8412	GUARD ASSEM. --(L. H. inner)- (Includes)	1
14	6S7843	STRIP-----	1
15	6S8413	GUARD ASSEM. --(L. H. outer)- (Includes)	1
16	6S7843	STRIP-----	1
17	6S9598	PLATE-----	1
18	6S9696	GUARD ASSEM.-----	1

19	3B4508	LOCKWASHER-----	12
20	7B3235	BOLT-----	8
21	S1623	BOLT-----	4
22	6S9235	BRACKET ASSEM.-----	2

165831



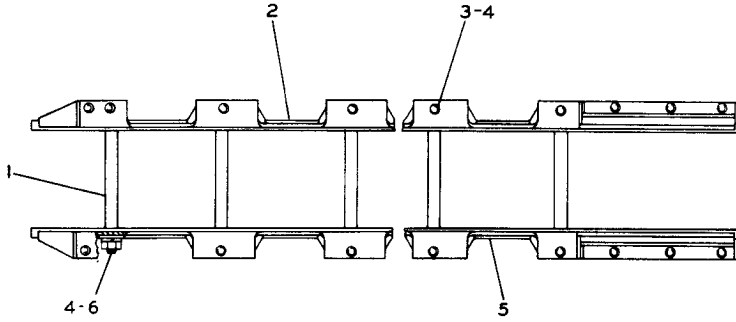

REF. NO.	PART NUMBER	DESCRIPTION	QTY
1	6S3429	PIPE-----	12
2	6S9628	GUARD ASSEM.-----	2
3	S1595	BOLT-----	40
	4B4280	WASHER-----	40
4	3B4508	LOCKWASHER-----	52

5	6S9627	GUARD ASSEM.-----	2
	2D516	BOLT-----	12
	1D4719	NUT-----	12

165824

## 5G382 TRACK ROLLER GUARD GROUP

Serial No. 79U4167, 4168, 4216, 4233 to 4263, 4265, 4266, 4268 to 4294, 4297, 4298, 4300 to 4323, 4325 to 4327 & 79U4329—Up. Note: Quantities shown are those required for both R.H. & L.H. sides. AN ATTACHMENT

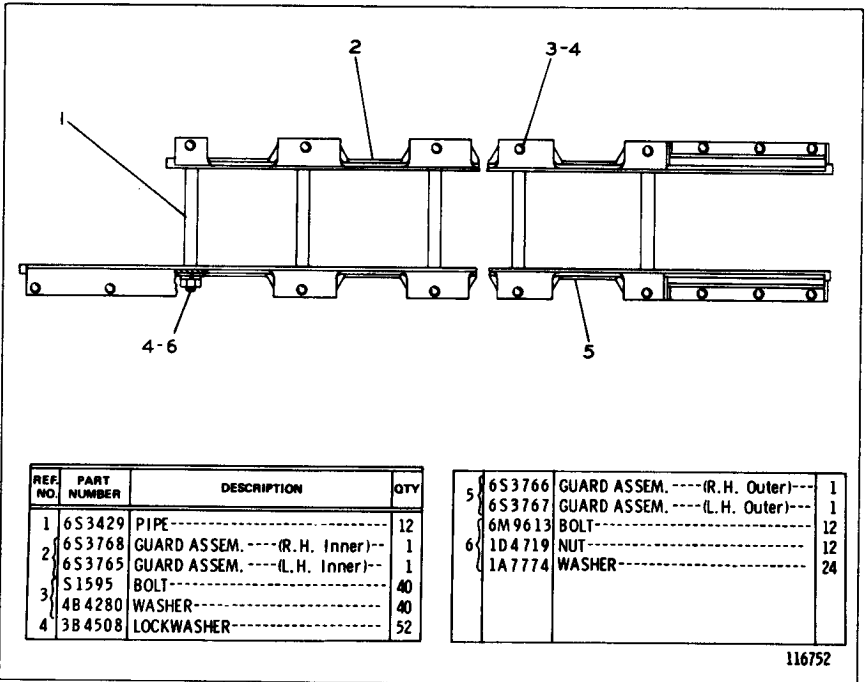

6S3553 TRACK ROLLER GUARD GROUP

Serial No. 79U1 to 4166, 4169 to 4215, 4217 to 4232, 4264, 4267, 4295, 4296, 4324 & 79U4328 inclusive. Note: Quantities shown are those required for both R.H. and L.H. sides. AN ATTACHMENT

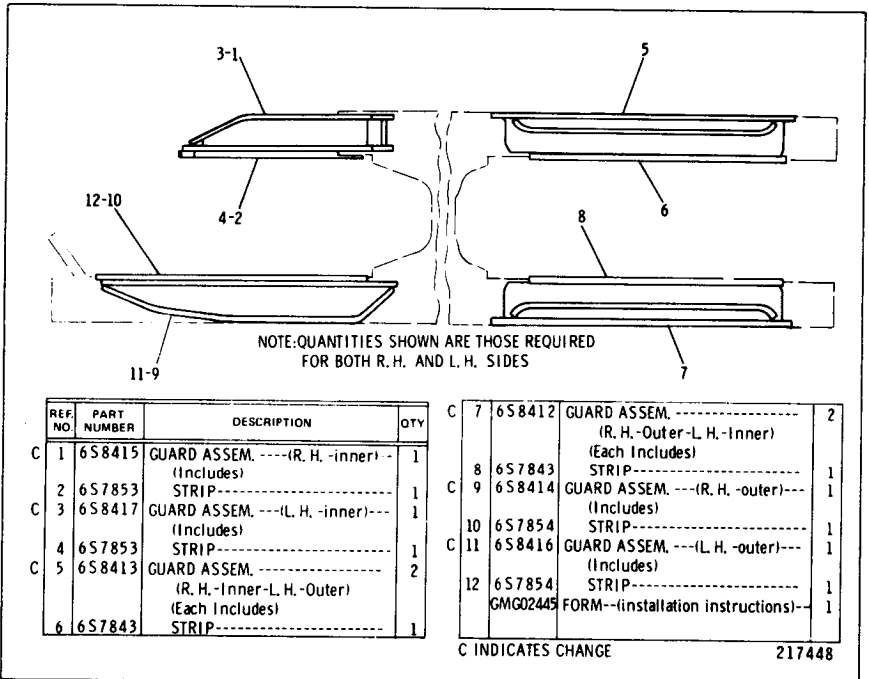

6S7872 TRACK GUIDING GUARD GROUP—Weld-On—Field Installation

Serial No. 79U1 to 79U4166, 4169 to 4215, 4217 to 4232, 4264, 4267, 4295, 4296, 4324 & 79U4328 inclusive

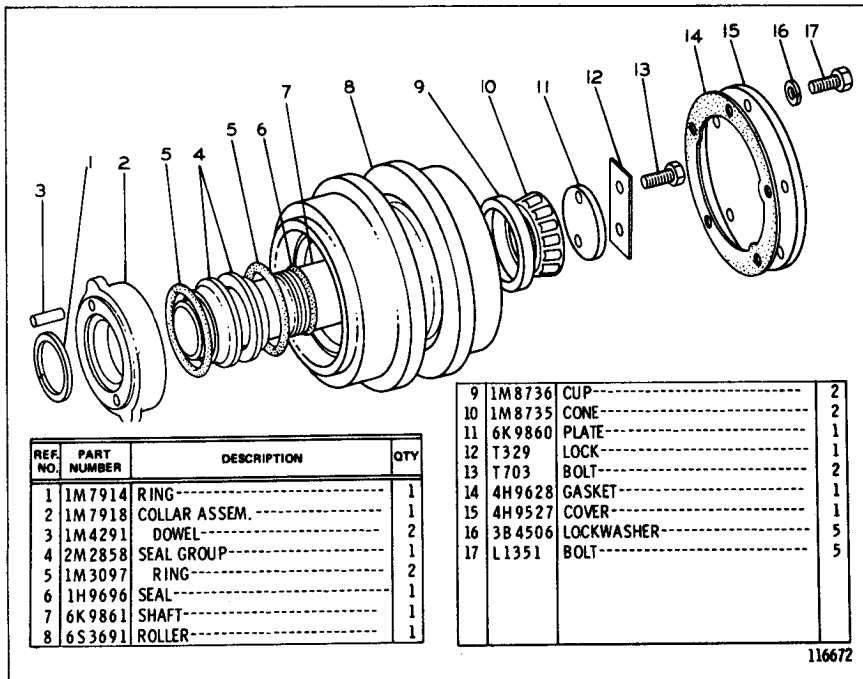

REF. NO.	PART NUMBER	DESCRIPTION	QTY
1	1M 7914	RING-----	1
2	1M 7918	COLLAR ASSEM.-----	1
3	1M 4291	DOWEL-----	2
4	2M 2858	SEAL GROUP-----	1
5	1M 3097	RING-----	2
6	1H 9696	SEAL-----	1
7	6K 9861	SHAFT-----	1
8	6S 3691	ROLLER-----	1

9	1M 8736	CUP-----	2
10	1M 8735	CONE-----	2
11	6K 9860	PLATE-----	1
12	T 329	LOCK-----	1
13	T 703	BOLT-----	2
14	4H 9628	GASKET-----	1
15	4H 9527	COVER-----	1
16	3B 4506	LOCKWASHER-----	5
17	L 1351	BOLT-----	5

116672

6S3609 TRACK CARRIER ROLLER GROUP—2 Required

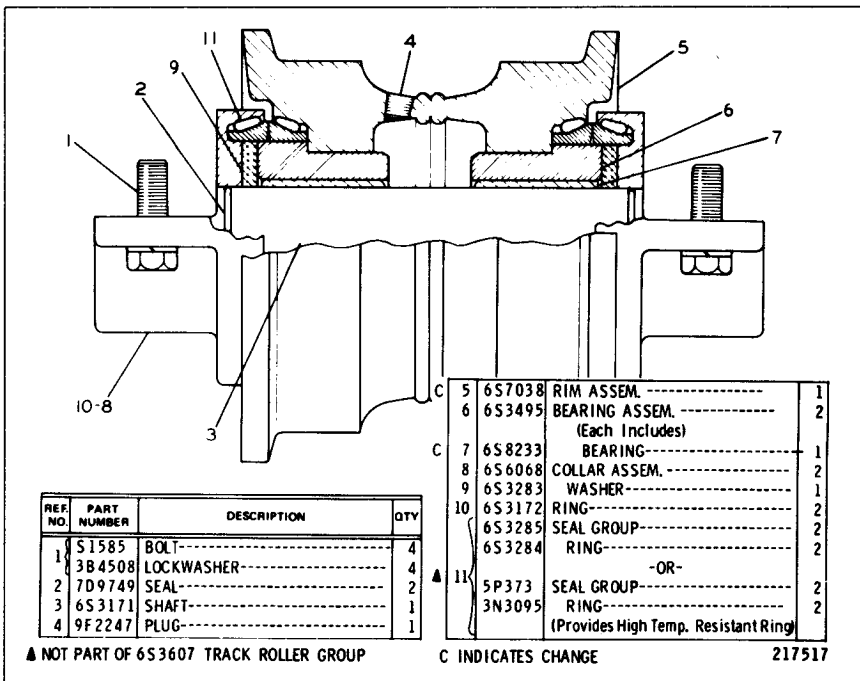

6S3607 TRACK ROLLER GROUP—Single Flange—4 Required  
 Serial No. 79U1 to 1672, 1686, 1691, 1693, 1694, 1700, 1703, 1712, 1714, 1720, 1723, 1725, 1731, 1733 and 79U1734 inclusive

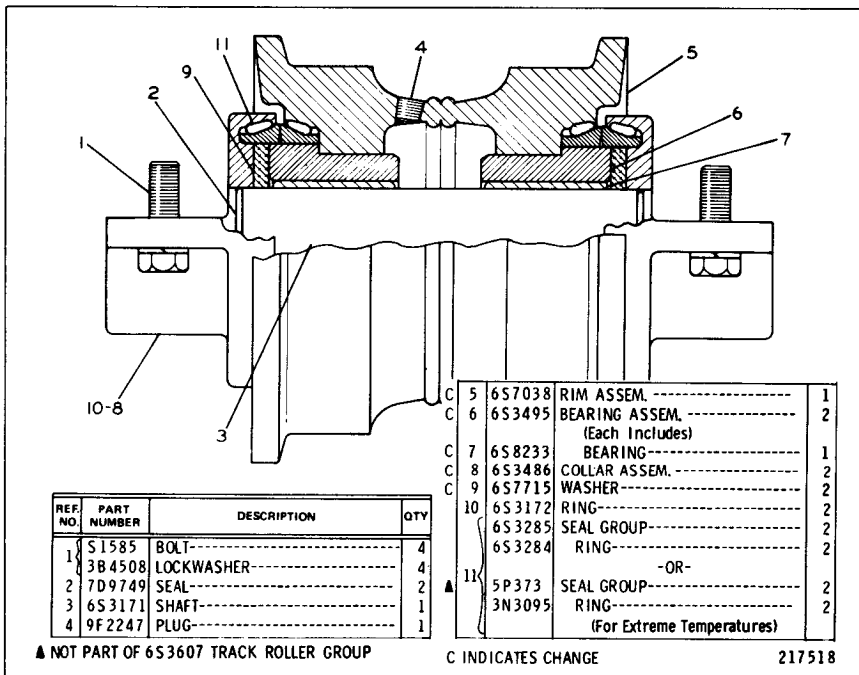

6S3607 TRACK ROLLER GROUP—Single Flange—4 Required  
 Serial No. 79U1673 to 1685, 1687 to 1690, 1692, 1695 to 1699, 1701, 1702, 1704 to 1711, 1713, 1715 to 1719, 1721, 1722, 1724, 1726 to 1730, 1732 and 79U1735—Up

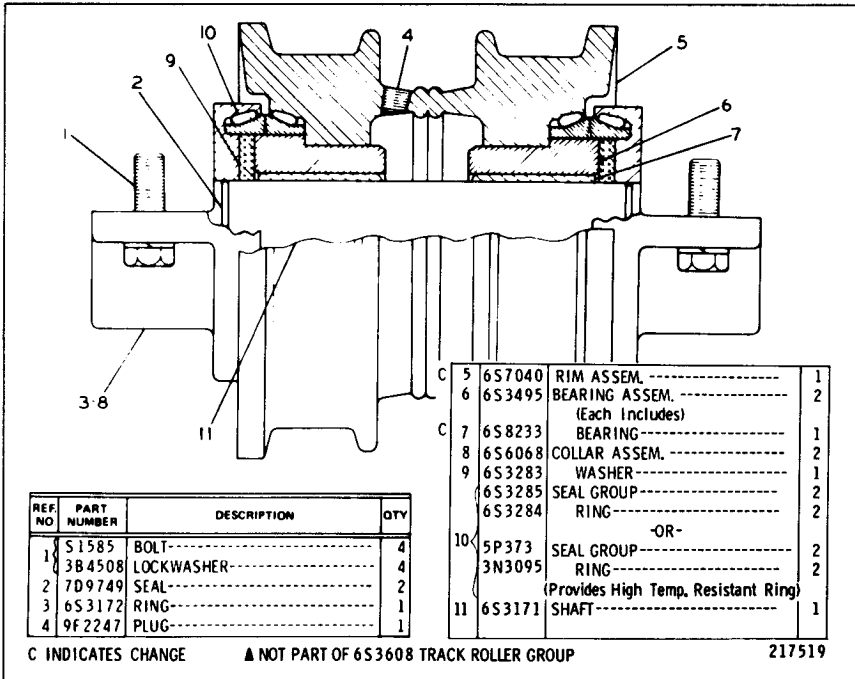

6S3608 TRACK ROLLER GROUP—Double Flange—6 Required  
 Serial No. 79U1 to 1679, 1686, 1691, 1693, 1694, 1700, 1703, 1712, 1714, 1720,  
 1723, 1725, 1731, 1733 and 79U1734 inclusive

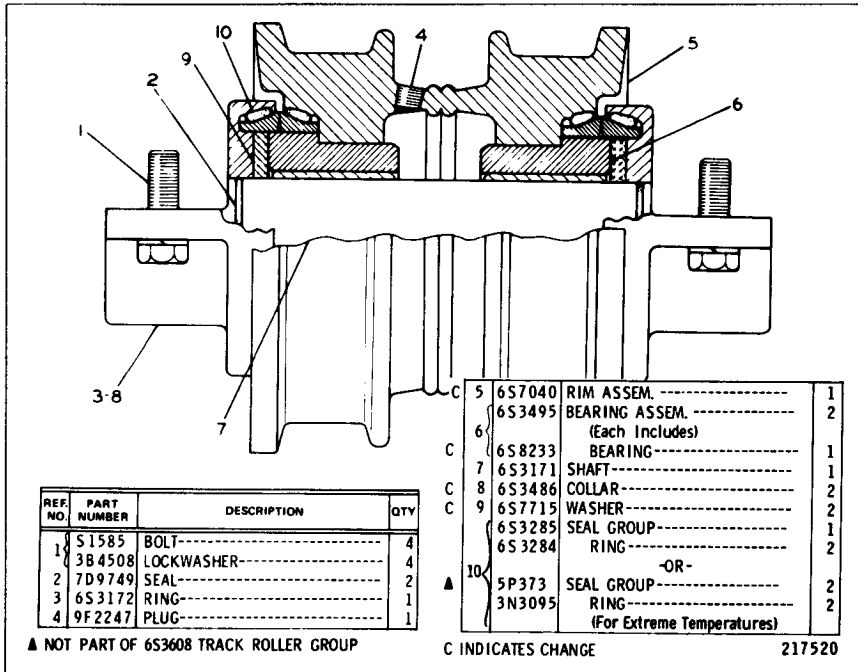

6S3608 TRACK ROLLER GROUP—Double Flange—6 Required  
 Serial No. 79U1680 to 1685, 1687 to 1690, 1692, 1695 to 1699, 1701, 1702, 1704 to  
 1711, 1713, 1715 to 1719, 1721, 1722, 1724, 1726 to 1730, 1732 and 79U1735—Up

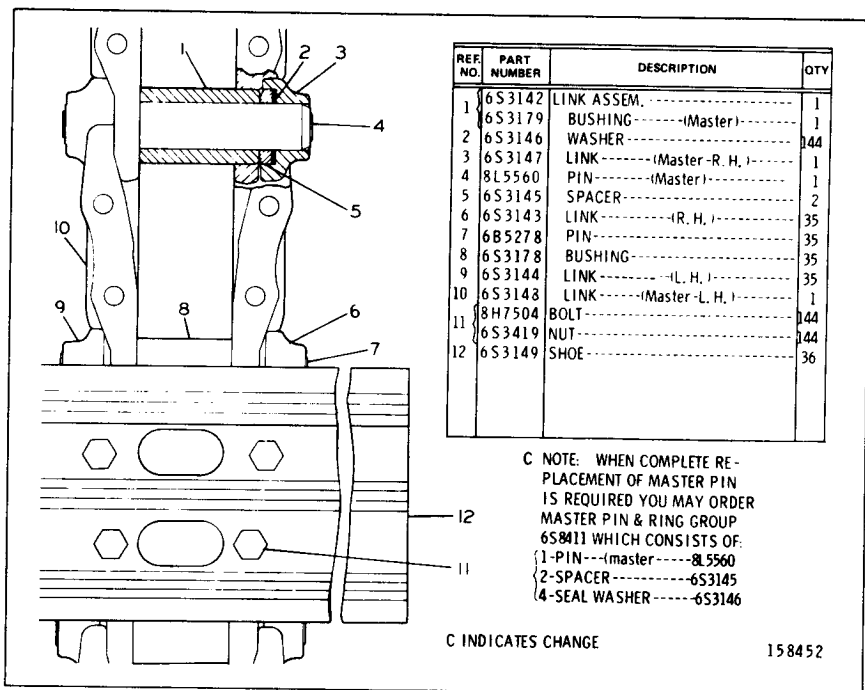

6S3427 TRACK GROUP—356 mm (14") Triple Grouser Shoe—2 Required  
 Replaced by 6S8829 shown on Page 66. Note: 6S8408 Track Pin and Bushing Group, consisting of a complete set of Pins and Bushings for one Track, is available AN ATTACHMENT

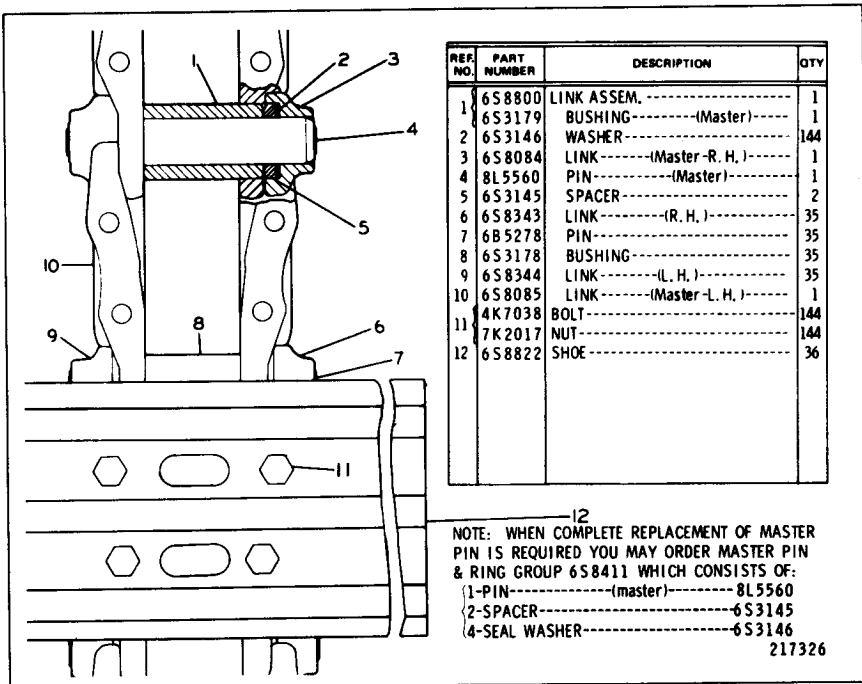

6S8829 TRACK GROUP—356 mm (14") Triple Grouser Shoe—2 Required  
 Note: 6S8408 Track Pin and Bushing Group, consisting of a complete set of Pins and Bushings for one Track, is available. AN ATTACHMENT

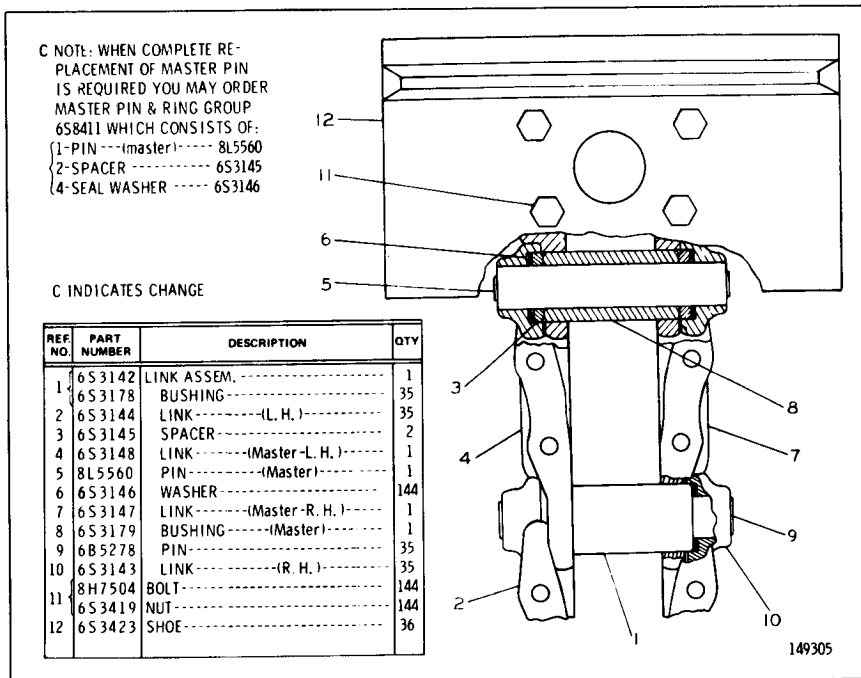

6S3180 TRACK GROUP—305 mm (12") Single Grouser Shoe—2 Required  
 Serial No. 79U1 to 79U3050 inclusive  
 Note: 6S8408 Track Pin and Bushing Group, consisting of a complete set of Pins and Bushings for one Track, is available

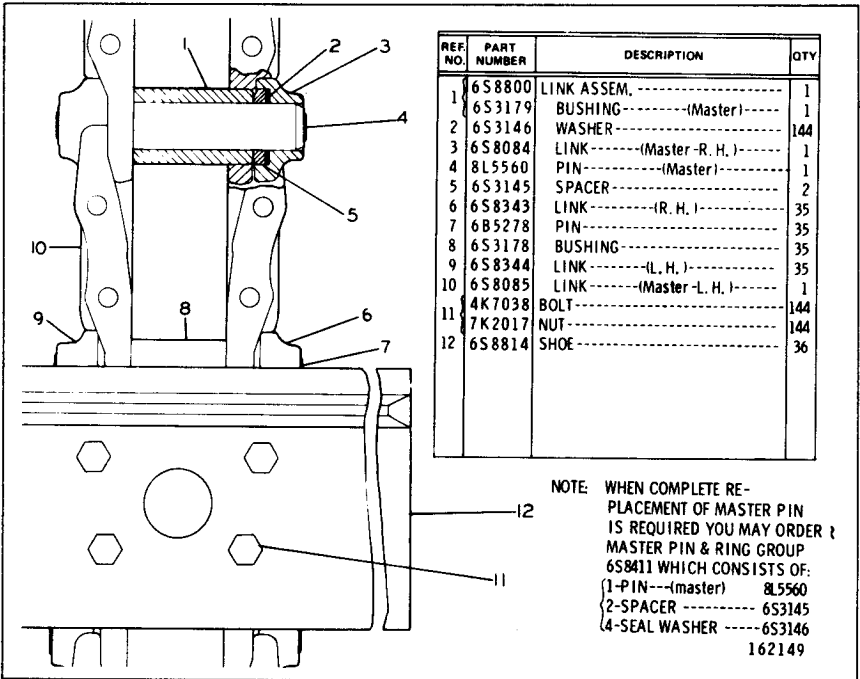

6S8799 TRACK GROUP—12" (305 mm) Single Grouser Shoe—2 Required  
 Serial No. 79U3051—Up

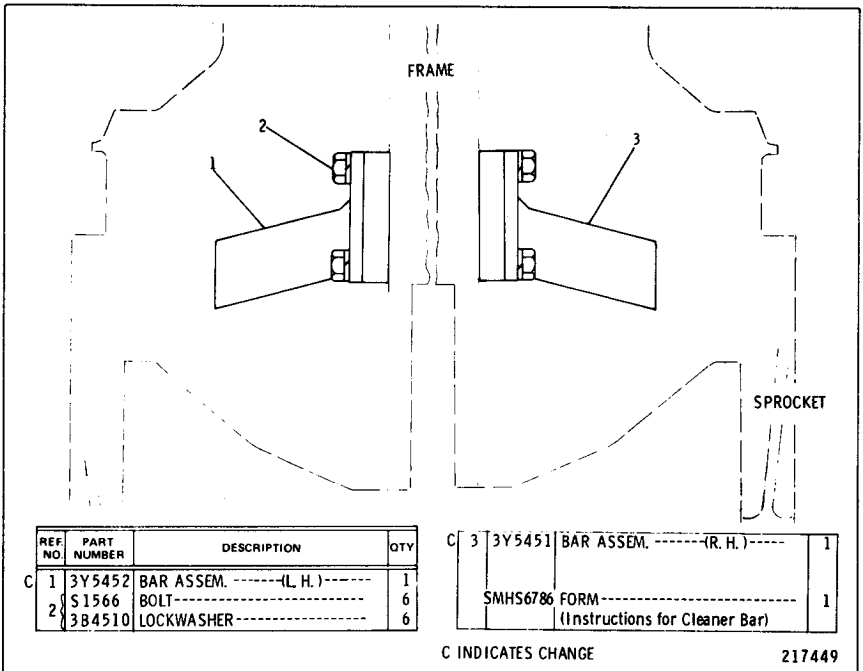

6S9359 TRACK CLEANER BAR GROUP—Field Installation



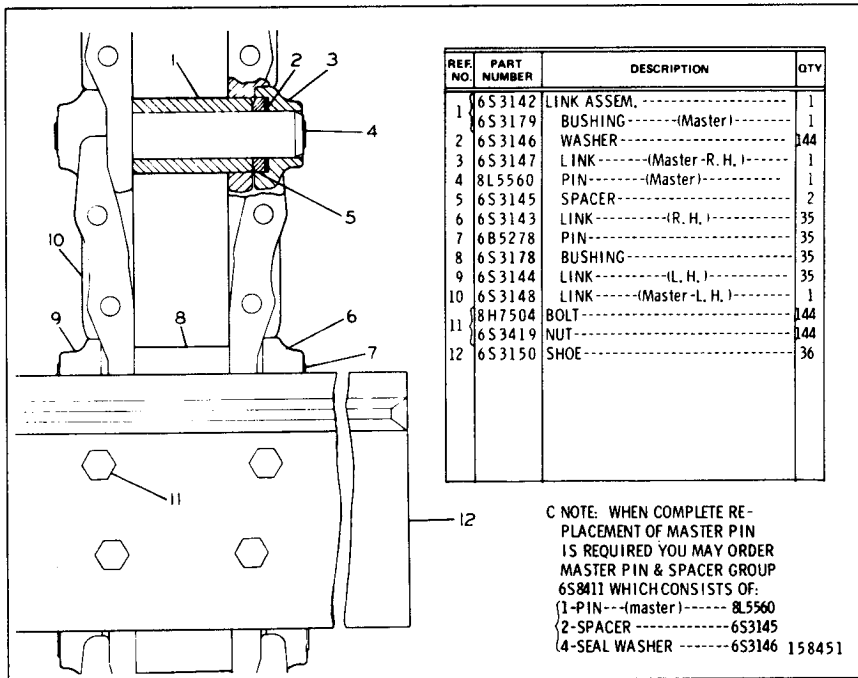

**6S3425 TRACK GROUP—14" (356 mm) Single Grouser Shoe—2 Required**  
 Replaced by 6S8830 Track Group. Note: 6S8408 Track Pin and Bushing Group, consisting  
 of a complete set of Pins and Bushings for one Track, is available. AN ATTACHMENT

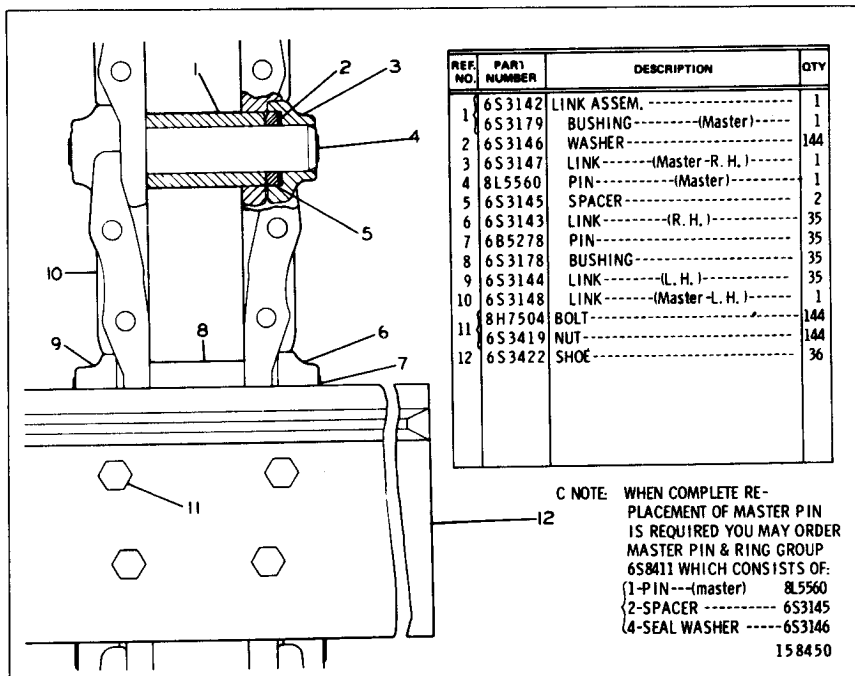

**6S3428 TRACK GROUP—16" (406 mm) Single Grouser Shoe—2 Required**  
 Replaced by 6S8831 Track Group. Note: 6S8408 Track Pin and Bushing Group, consisting  
 of a complete set of Pins and Bushings for one Track, is available. AN ATTACHMENT

REF. NO.	PART NUMBER	DESCRIPTION	QTY
1	6S8800	LINK ASSEM. -----	1
1	6S3179	BUSHING----- (Master)-----	1
2	6S3146	WASHER-----	144
3	6S8084	LINK----- (Master-R. H.)-----	1
4	8L5560	PIN----- (Master)-----	1
5	6S3145	SPACER-----	2
6	6S8343	LINK----- (R. H.)-----	35
7	6B5278	PIN-----	35
8	6S3178	BUSHING-----	35
9	6S8344	LINK----- (L. H.)-----	35
10	6S8085	LINK----- (Master-L. H.)-----	1
11	4K7038	BOLT-----	144
	7K2017	NUT-----	144
12	6S8815	SHOE-----	36

NOTE: WHEN COMPLETE RE-PLACEMENT OF MASTER PIN IS REQUIRED YOU MAY ORDER MASTER PIN & SPACER GROUP 6S8411 WHICH CONSISTS OF:  
 {1-PIN---(master)----- 8L5560  
 {2-SPACER ----- 6S3145  
 {4-SEAL WASHER ----- 6S3146 158943

6S8830 TRACK GROUP—14" (356 mm) Single Grouser Shoe—2 Required AN ATTACHMENT

REF. NO.	PART NUMBER	DESCRIPTION	QTY
1	6S8800	LINK ASSEM. -----	1
1	6S3179	BUSHING----- (Master)-----	1
2	6S3146	WASHER-----	144
3	6S8084	LINK----- (Master-R. H.)-----	1
4	8L5560	PIN----- (Master)-----	1
5	6S3145	SPACER-----	2
6	6S8343	LINK----- (R. H.)-----	35
7	6B5278	PIN-----	35
8	6S3178	BUSHING-----	35
9	6S8344	LINK----- (L. H.)-----	35
10	6S8085	LINK----- (Master-L. H.)-----	1
11	4K7038	BOLT-----	144
	7K2017	NUT-----	144
12	6S8817	SHOE-----	36

NOTE: WHEN COMPLETE RE-PLACEMENT OF MASTER PIN IS REQUIRED YOU MAY ORDER MASTER PIN & RING GROUP 6S8411 WHICH CONSISTS OF:  
 {1-PIN---(master)----- 8L5560  
 {2-SPACER ----- 6S3145  
 {4-SEAL WASHER ----- 6S3146 158944

6S8831 TRACK GROUP—16" (406 mm) Single Grouser Shoe—2 Required AN ATTACHMENT

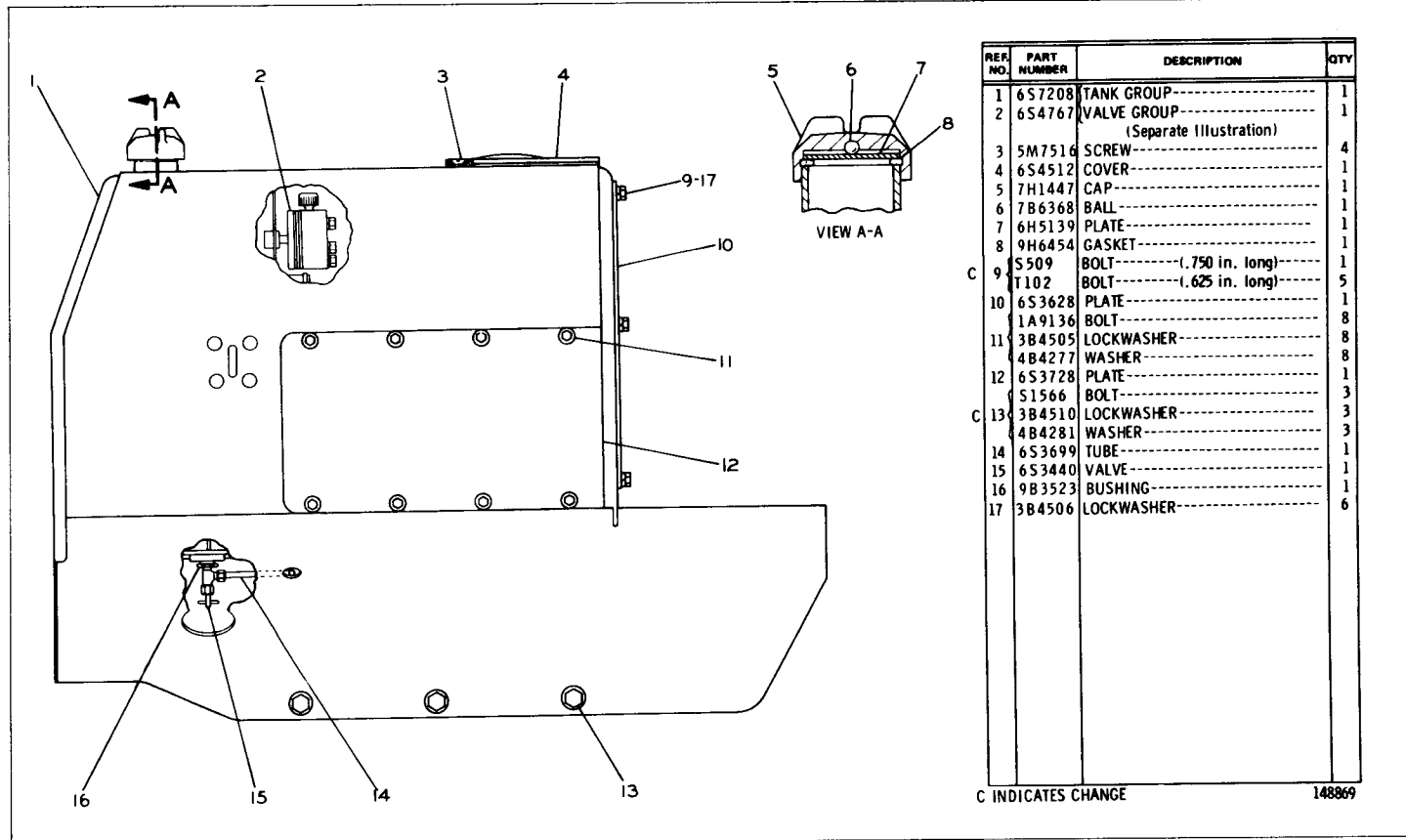

REF. NO.	PART NUMBER	DESCRIPTION	QTY
1	6S7208	TANK GROUP	1
2	6S4767	VALVE GROUP	1
		(Separate Illustration)	
3	5M7516	SCREW	4
4	6S4512	COVER	1
5	7H1447	CAP	1
6	7B6368	BALL	1
7	6H5139	PLATE	1
8	9H6454	GASKET	1
C 9	S509	BOLT-----(.750 in. long)	1
	T102	BOLT-----(.625 in. long)	5
10	6S3628	PLATE	1
	1A9136	BOLT	8
11	3B4505	LOCKWASHER	8
	4B4277	WASHER	8
12	6S3728	PLATE	1
	S1566	BOLT	3
C 13	3B4510	LOCKWASHER	3
	4B4281	WASHER	3
14	6S3699	TUBE	1
15	6S3440	VALVE	1
16	9B3523	BUSHING	1
17	3B4506	LOCKWASHER	6

C INDICATES CHANGE

148869

6S3536 HYDRAULIC TANK AND VALVE GROUP  
 Serial No. 79U1596 to 79U3880 inclusive  
 6S7208 Tank & 6S4767 Valve parts are shown on Pages 69 & 70

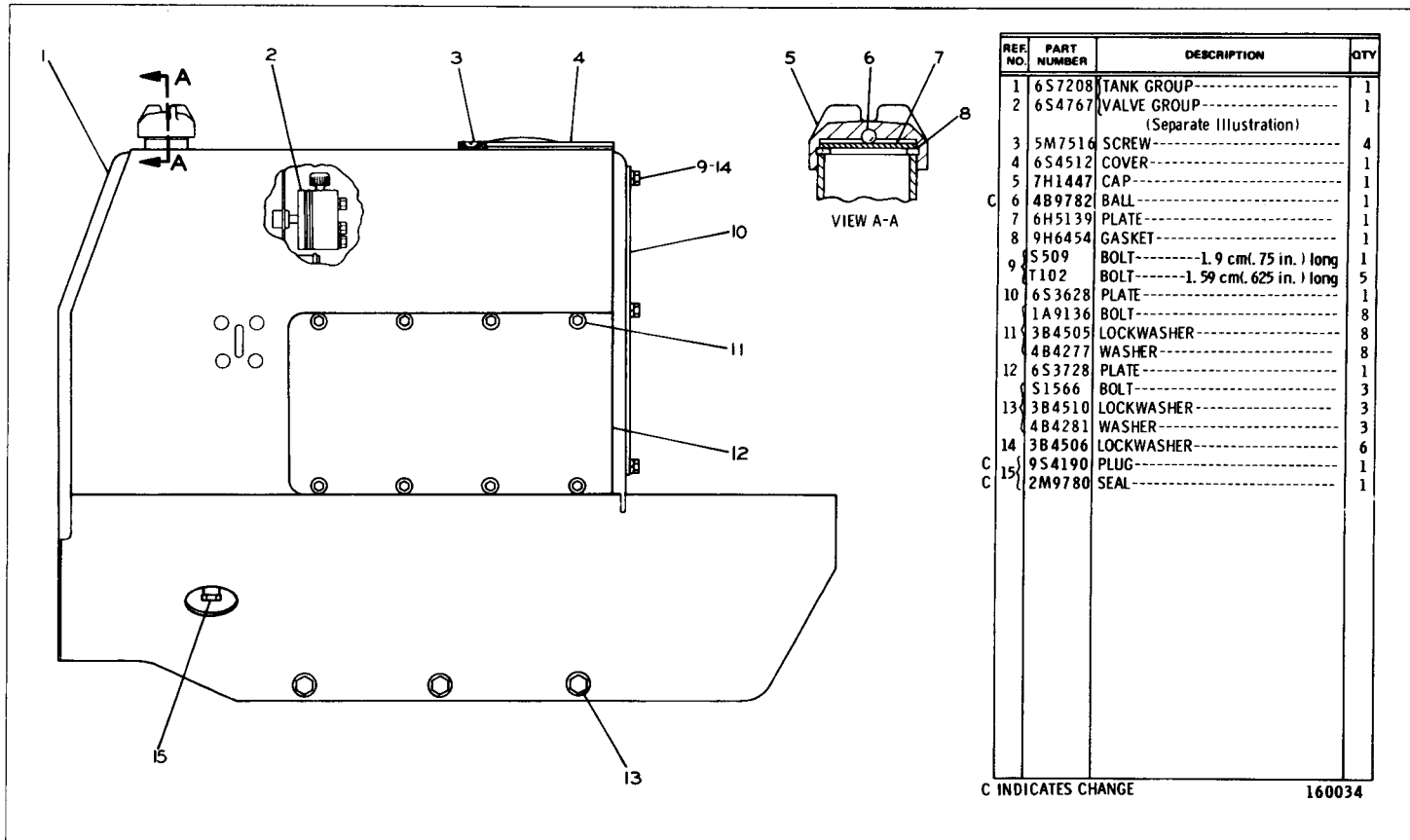

REF. NO.	PART NUMBER	DESCRIPTION	QTY
1	6S7208	TANK GROUP-----	1
2	6S4767	VALVE GROUP----- (Separate Illustration)	1
3	5M7516	SCREW-----	4
4	6S4512	COVER-----	1
5	7H1447	CAP-----	1
6	4B9782	BALL-----	1
7	6H5139	PLATE-----	1
8	9H6454	GASKET-----	1
9	S509	BOLT-----1.9 cm(.75 in.) long	1
9	T102	BOLT-----1.59 cm(.625 in.) long	5
10	6S3628	PLATE-----	1
10	1A9136	BOLT-----	8
11	3B4505	LOCKWASHER-----	8
11	4B4277	WASHER-----	8
12	6S3728	PLATE-----	1
12	S1566	BOLT-----	3
13	3B4510	LOCKWASHER-----	3
13	4B4281	WASHER-----	3
14	3B4506	LOCKWASHER-----	6
15	9S4190	PLUG-----	1
15	2M9780	SEAL-----	1

C INDICATES CHANGE

160034

HYDRAULIC SYSTEM

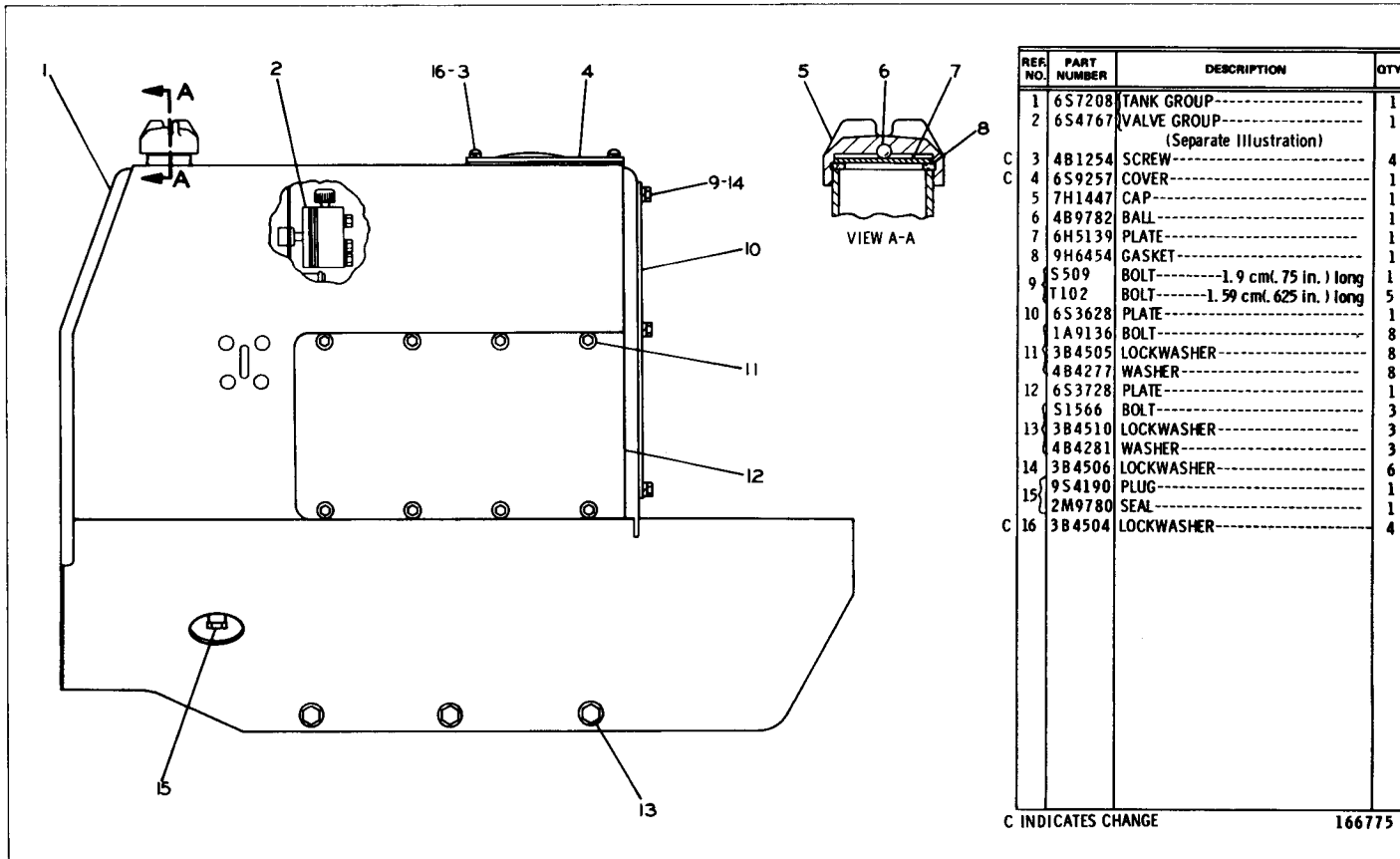

## 6S3536 HD HYDRAULIC TANK AND VALVE GROUP

Serial No. 79U3881—Up

6S7208 Tank and 6S4767 Valve parts are shown on Pages 69 &amp; 70

6S7208 HYDRAULIC TANK GROUP  
 Part of 6S3536 Hydraulic Tank and Valve Group shown on Page 68

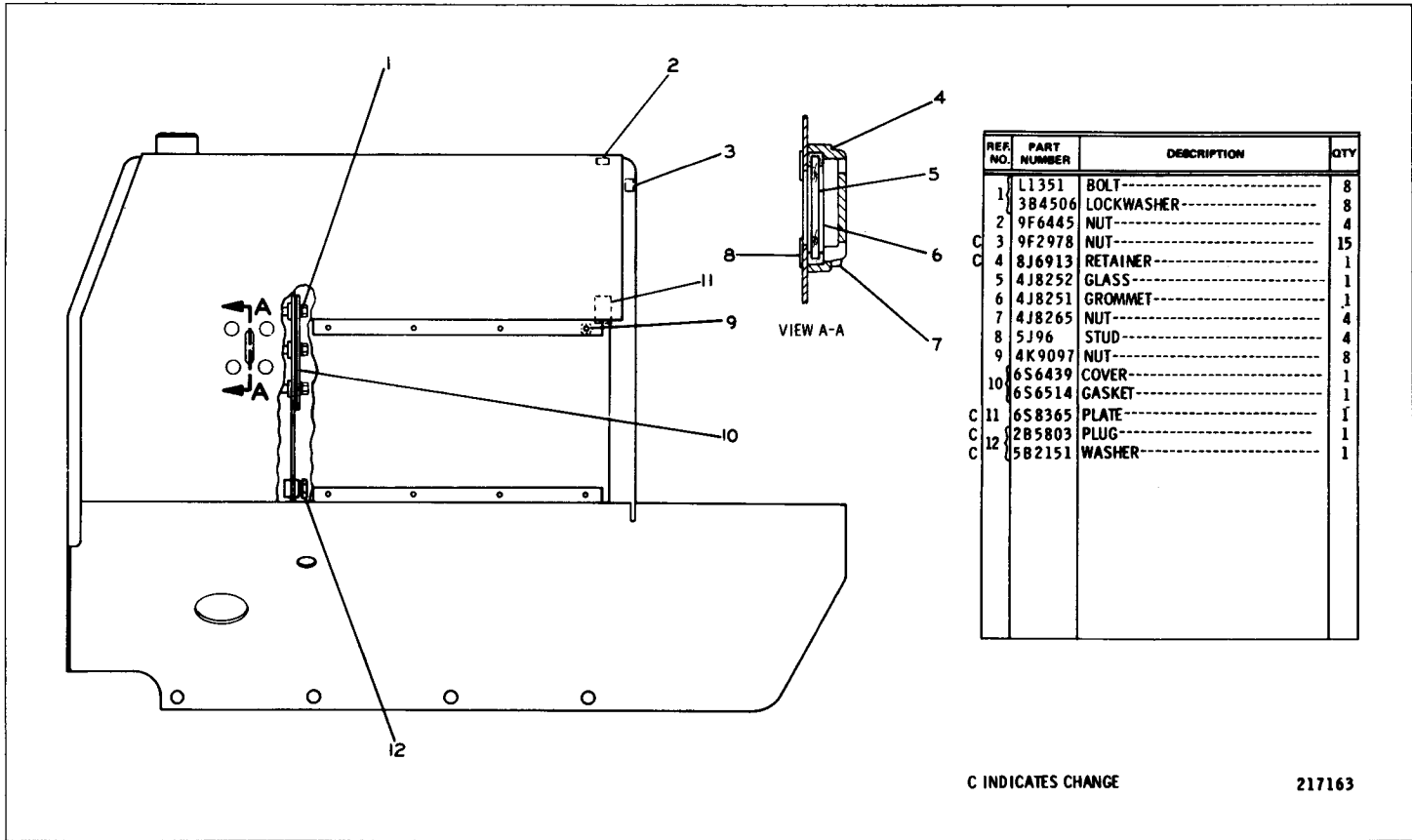

REF. NO.	PART NUMBER	DESCRIPTION	QTY
1	L1351	BOLT-----	8
	384506	LOCKWASHER-----	8
2	9F6445	NUT-----	4
3	9F2978	NUT-----	15
4	8J6913	RETAINER-----	1
5	4J8252	GLASS-----	1
6	4J8251	GROMMET-----	1
7	4J8265	NUT-----	4
8	5J96	STUD-----	4
9	4K9097	NUT-----	8
10	6S6439	COVER-----	1
	6S6514	GASKET-----	1
C 11	6S8365	PLATE-----	1
C 12	2B5803	PLUG-----	1
C	5B2151	WASHER-----	1

C INDICATES CHANGE

217163

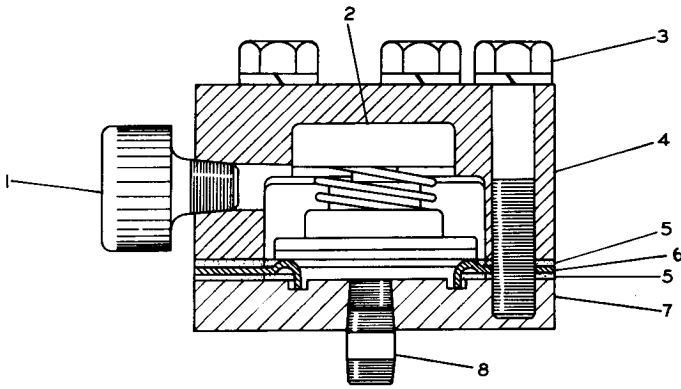

REF. NO.	PART NUMBER	DESCRIPTION	QTY
1	8S5820	BREATHER-----	1
2	5S1218	VALVE ASSEM.-----	1
3	2B2694	BOLT-----	3
3	3B4505	LOCKWASHER-----	3
4	6S4768	COVER-----	1
5	6S4795	GASKET-----	2

6	7S4252	PLATE-----	1
7	6S4769	PLATE-----	1
8	3B7738	NIPPLE-----	1

118694

**6S4767 BREAKER RELIEF VALVE GROUP**  
Part of Hydraulic Tank and Valve shown on Page 68

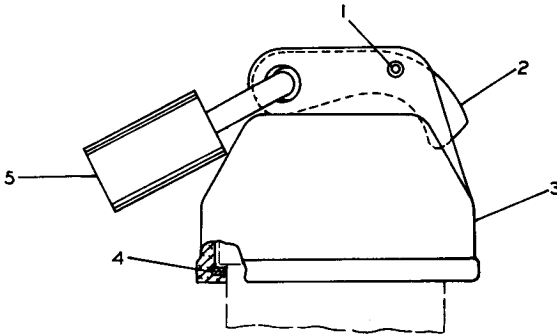

▲ Not Part of Protection Cover Group 5D1910

REF. NO.	PART NUMBER	DESCRIPTION	QTY
1	1L5072	DOWEL-----	1
2	9M7394	LEVER-----	1
3	5D1911	COVER-----	1
4	2J7761	RING-----	1

5	Not Serv	PADLOCK-----	1
		(For Service of Padlock & Key Order 8S7949 Padlock Group)	
▲	8M439	KEY-----	2
		(NOT SHOWN)	

113719

**5D1910 PROTECTION COVER GROUP—Hydraulic Tank Cap**  
Part of 6S3537 Vandalism Protection Arrangement listed on Page 89  
**AN ATTACHMENT**

6S3413	ARRANGEMENT--3 VALVE--FOR USE WITH 3P BULLDOZER		
	CONSISTS OF:		PAGE
1	8J4512	GEAR PUMP GROUP.....	78
1	6S3415	CONTROL VALVE GROUP.....	76
1	6S3416	HYDRAULIC HAND CONTROL GROUP.....	72
1	6S3418	PUMP LINES GROUP.....	80
1	6S3543	OIL FILTER GROUP.....	83
1	.....	INSTRUCTION FORM GMG02246	
6S3618	ARRANGEMENT--4 VALVE--FOR USE WITH 3P BULLDOZER AND RIPPER		
	CONSISTS OF:		
1	8J4512	GEAR PUMP GROUP.....	78
1	6S3418	PUMP LINES GROUP.....	80
1	6S3543	OIL FILTER GROUP.....	83
1	6S3619	CONTROL VALVE GROUP.....	76
1	6S3620	HYDRAULIC HAND CONTROL GROUP.....	72
1	6S4107	REAR LINES GROUP.....	81
1	.....	INSTRUCTION FORM GMG02246	
6S3684	ARRANGEMENT--3 VALVE--FOR USE WITH 3P, 3S BULLDOZERS WITH MECHANICALLY ANGLING BRACE AND FOR USE WITH RIPPER		
	CONSISTS OF:		
1	8J4512	GEAR PUMP GROUP.....	78
1	6S3418	PUMP LINES GROUP.....	80
1	6S3543	OIL FILTER GROUP.....	83
1	6S4111	REAR LINES GROUP.....	82
1	6S4488	CONTROL VALVE GROUP.....	77
1	6S4489	HYDRAULIC HAND CONTROL GROUP.....	73
1	.....	INSTRUCTION FORM GMG02246	
6S3703	ARRANGEMENT--2 VALVE--FOR USE WITH 3P, 3LGP, 3S AND 3S LGP BULLDOZERS WITH MECHANICALLY ANGLING BRACE		
	CONSISTS OF:		
1	8J4512	GEAR PUMP GROUP.....	78
1	6S3418	PUMP LINES GROUP.....	80
1	6S3543	OIL FILTER GROUP.....	83
1	6S3709	CONTROL VALVE GROUP.....	77
1	6S4499	HYDRAULIC HAND CONTROL GROUP.....	73
1	.....	INSTRUCTION FORM GMG02246	

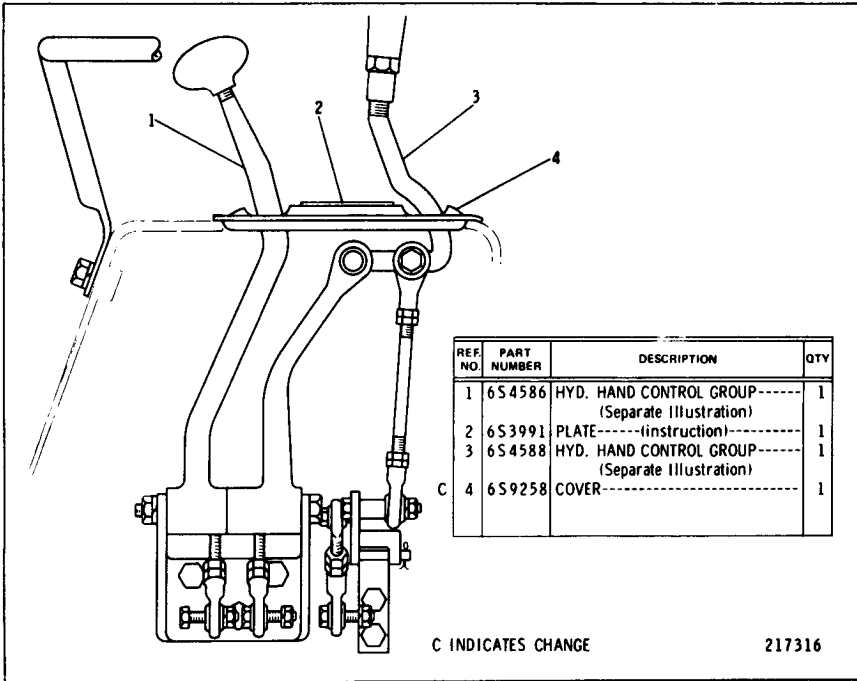

**6S3416 HYDRAULIC HAND CONTROL GROUP**

Part of 6S3413 Hydraulic Arrangement listed on Page 71. 6S4588 & 6S4586 Hand Control parts are shown on Pages 74 & 75

AN ATTACHMENT

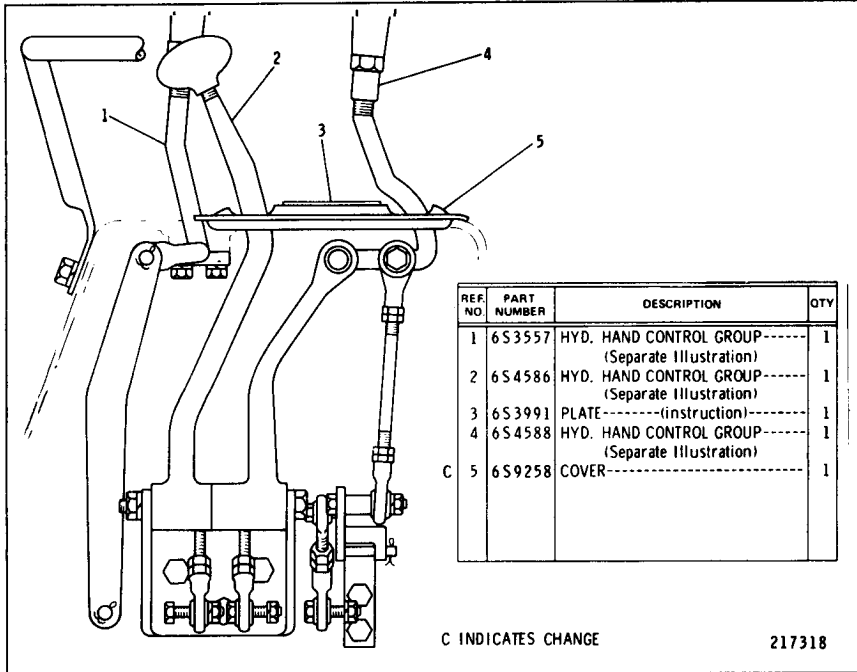
**6S3620 HYDRAULIC HAND CONTROL GROUP**

Part of 6S3618 Hydraulic Arrangement listed on Page 71. 6S4588, 6S4586 & 6S3557 Hand Control parts are shown on Pages 74 & 75

AN ATTACHMENT

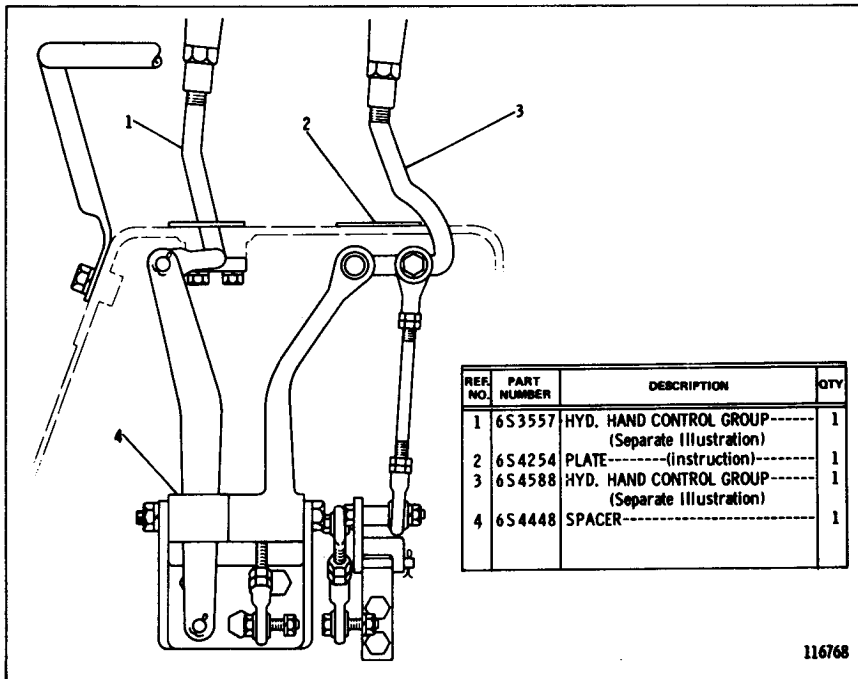

**6S4489 HYDRAULIC HAND CONTROL GROUP**  
 Part of 6S3684 Hydraulic Arrangement listed on Page 71  
 6S4588 & 6S3557 Hand Control parts are shown on Pages 74 & 75  
**AN ATTACHMENT**

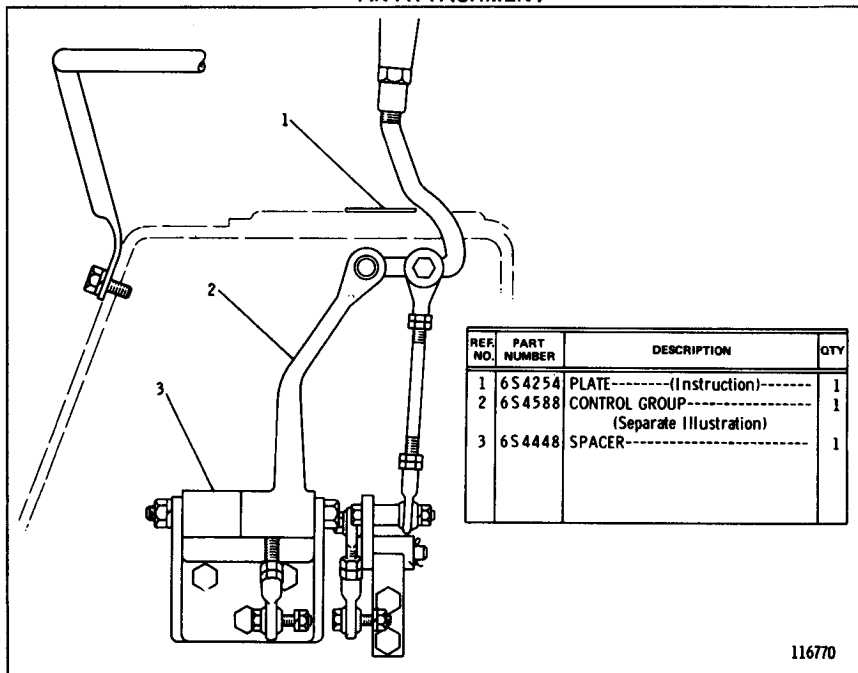

**6S4499 HYDRAULIC HAND CONTROL GROUP**  
 Part of 6S3703 Hydraulic Arrangement listed on Page 71  
 6S4588 Hand Control parts are shown on Page 74. **AN ATTACHMENT**

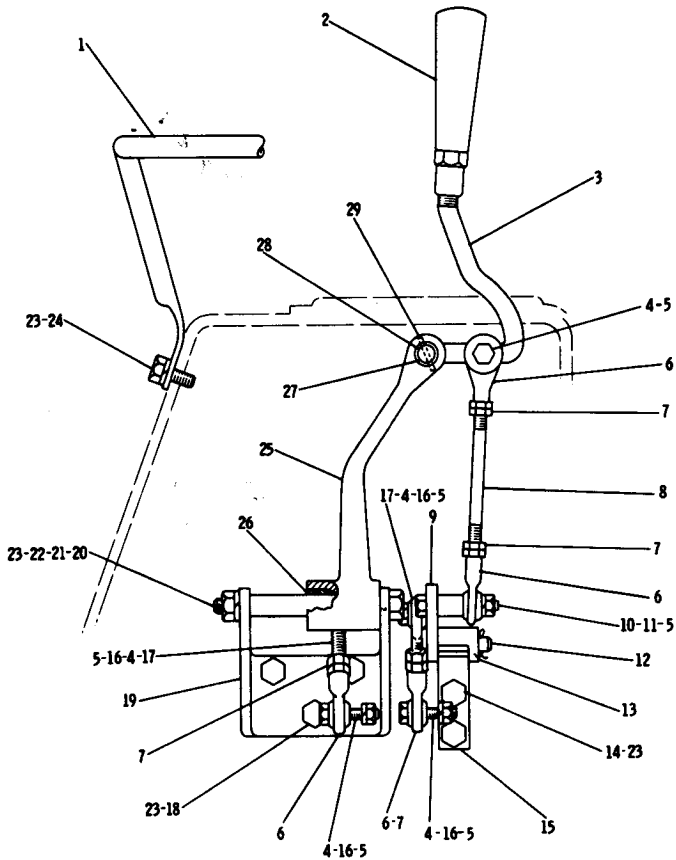

REF. NO.	PART NUMBER	DESCRIPTION	QTY
1	6S4100	GUARD ASSEM.-----	1
2	L829	HANDLE-----	1
3	6S4360	LEVER-----	1
4	4B3388	BOLT-----	5
5	3B4505	LOCKWASHER-----	6
6	7H3641	ROD END-----	4
7	1A8285	NUT-----	4
8	6S4454	ROD-----	1
9	6S4458	SPACER-----	1
10	1B9575	BOLT-----	1
11	4M5280	NUT-----	1
12	6S6107	PIN-----	1
13	3B4607	COTTER P IN-----	2
14	6S7979	LEVER ASSEM.-----	1
15	S1588	BOLT-----	2
16	6S4459	BLOCK-----	1
17	1D4716	NUT-----	4
17	6S6114	ROD END-----	2

18	S1594	BOLT-----	3
19	6S4436	PLATE-----	1
20	1A5964	BOLT-----	1
21	6S4438	SHAFT-----	1
22	1D4717	NUT-----	1
23	3B4506	LOCKWASHER-----	9
24	L1351	BOLT-----	3
25	6S4502	LEVER ASSEM.-----	1
26	2K2605	BEARING-----	2
27	2S1270	BEARING-----	2
28	6S4437	SHAFT-----	1
29	3K4897	PIN-----	1

116759

**6S4588 HYDRAULIC HAND CONTROL GROUP**  
 Part of 6S3416, 6S3620, 6S4489 & 6S4499 Hydraulic Hand Control  
 Groups shown on Pages 72 & 73. AN ATTACHMENT

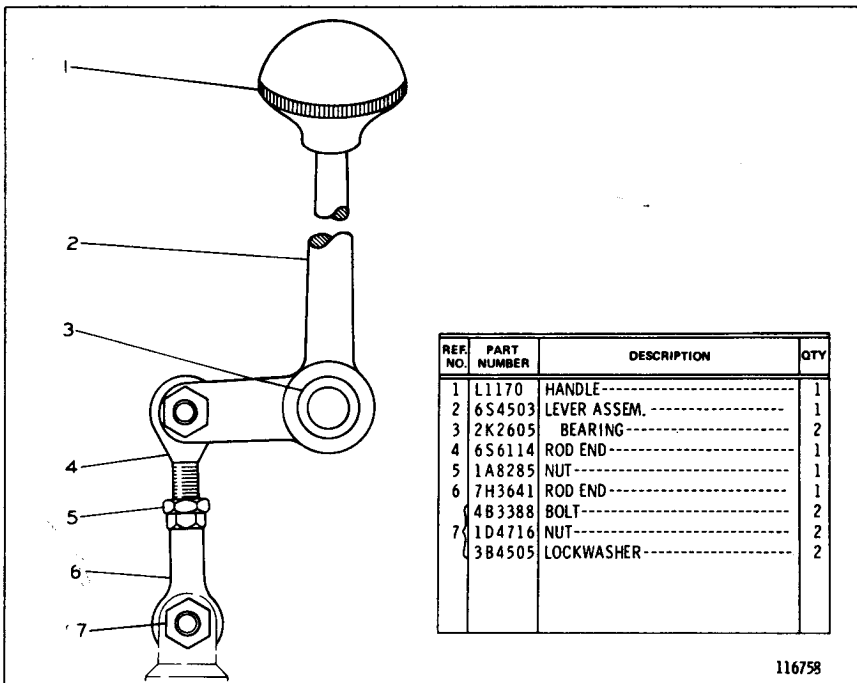

116758

6S4586 HYDRAULIC HAND CONTROL GROUP

Part of 6S3416 and 6S3620 Hydraulic Hand Control Groups shown on Page 72

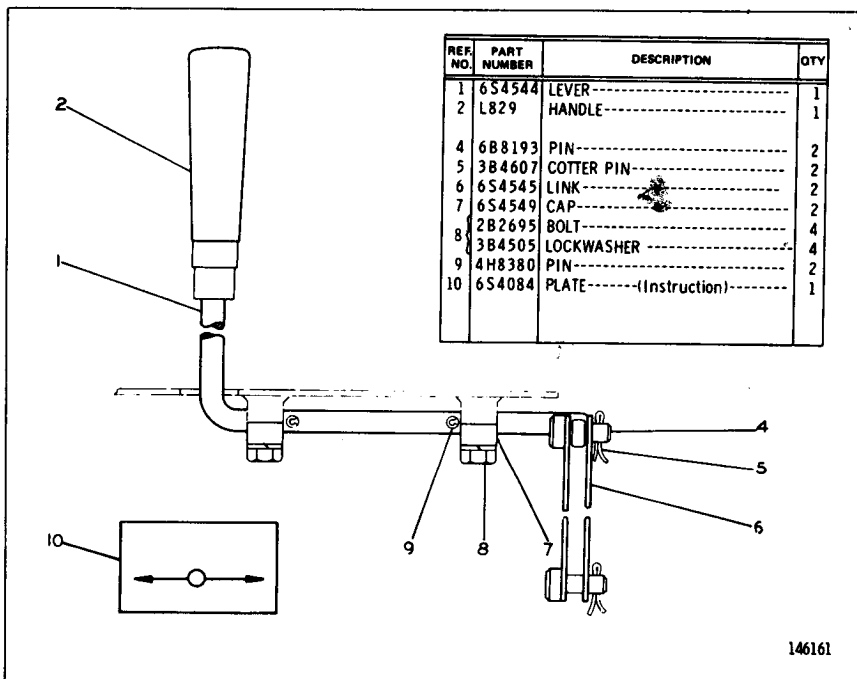

146161

6S3557 HYDRAULIC HAND CONTROL GROUP

Part of 6S3620 and 6S4489 Hydraulic Hand Control Groups shown on Pages 72 & 73

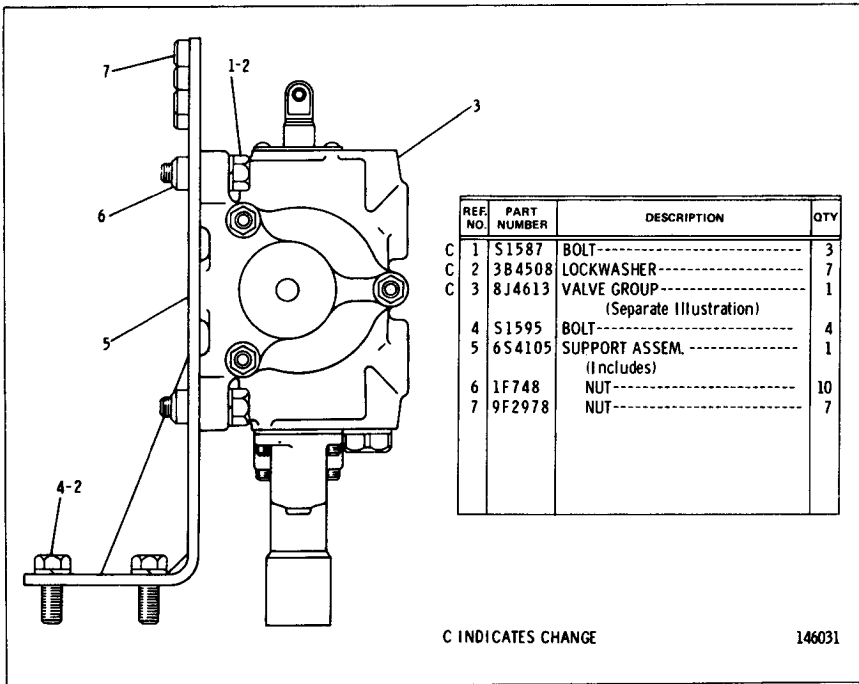

## 6S3415 CONTROL VALVE GROUP

Part of 6S3413 Hydraulic Arrangement listed on Page 71  
8J4613 Valve parts are shown on Page 77A

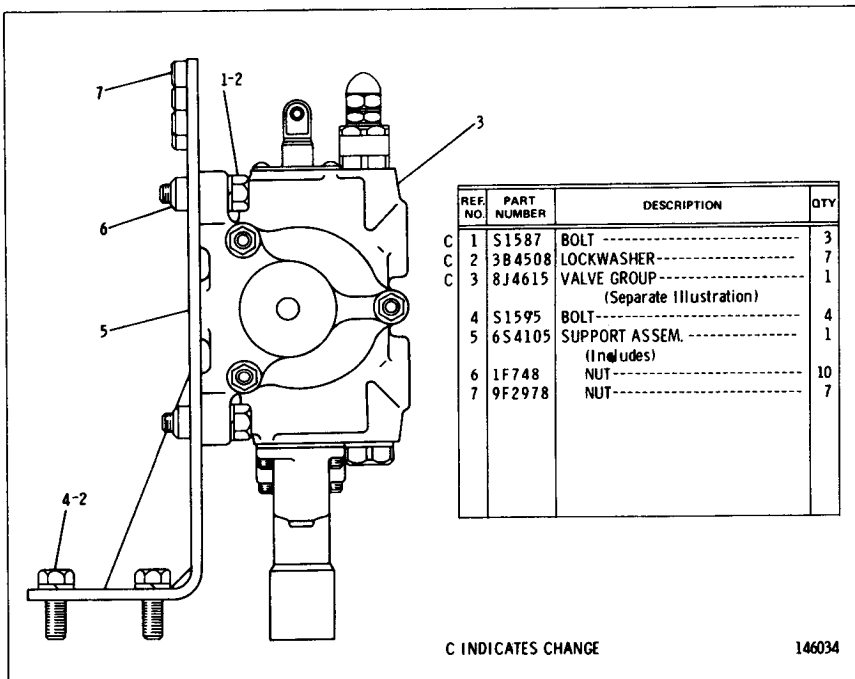

## 6S3619 CONTROL VALVE GROUP

Part of 6S3618 Hydraulic Arrangement listed on Page 71  
8J4615 Valve parts are shown on Page 77A

REF. NO.	PART NUMBER	DESCRIPTION	QTY
1	S1587	BOLT-----	3
2	3B4508	LOCKWASHER-----	7
C 3	9J5823	VALVE GROUP----- (Separate Illustration)	1
4	S1595	BOLT-----	4
5	6S4105	SUPPORT ASSEM.----- (Includes)	1
C 6	1F748	NUT-----	7
C 7	9F2978	NUT-----	5

MOUNTED IN HYDRAULIC TANK

C INDICATES CHANGE

217317

6S3415 CONTROL VALVE GROUP—Type 2  
 Part of 6S3413 Hydraulic Arrangement listed on Page 71  
 9J5823 Valve parts are shown on Page 77A-1

REF. NO.	PART NUMBER	DESCRIPTION	QTY
1	S1587	BOLT-----	3
2	3B4508	LOCKWASHER-----	7
C 3	9J5825	VALVE GROUP----- (Separate Illustration)	1
4	S1595	BOLT-----	4
5	6S4105	SUPPORT ASSEM.----- (Includes)	1
C 6	1F748	NUT-----	7
C 7	9F2978	NUT-----	5

MOUNTED IN HYDRAULIC TANK

C INDICATES CHANGE

217314

6S3619 CONTROL VALVE GROUP—Type 2  
 Part of 6S3618 Hydraulic Arrangement listed on Page 71  
 9J5825 Valve parts are shown on Page 77A-1

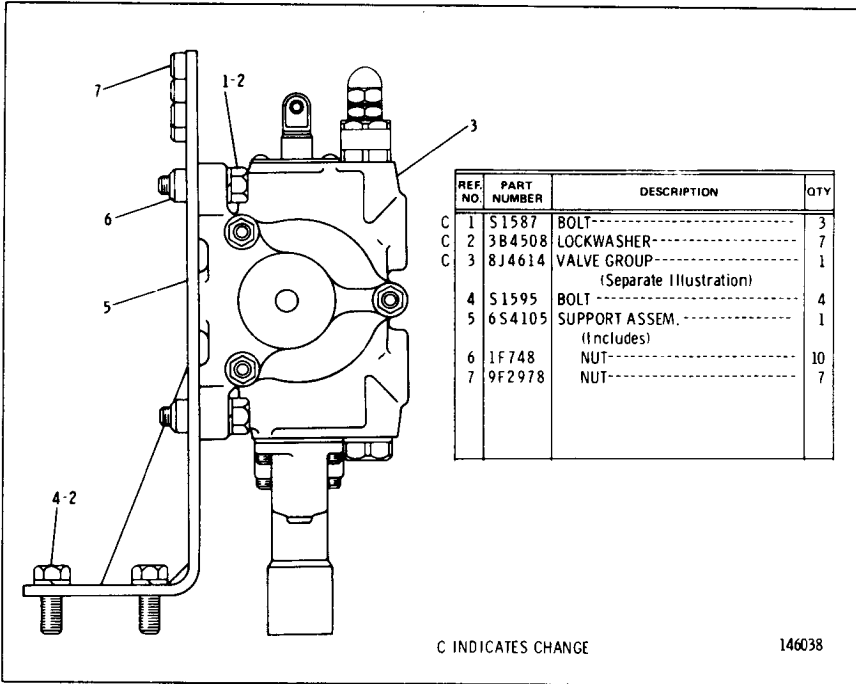

6S4488 CONTROL VALVE GROUP—Type 1  
Part of 6S3684 Hydraulic Arrangement listed on Page 71  
8J4614 Valve parts are shown on Page 77B

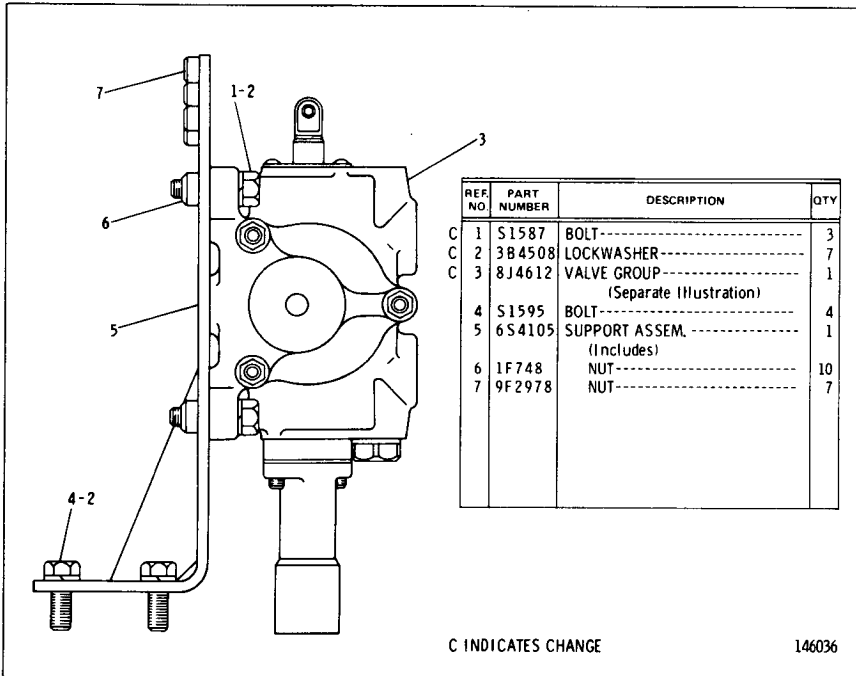

6S3709 CONTROL VALVE GROUP—Type 1  
Part of 6S3703 Hydraulic Arrangement listed on Page 71  
8J4612 Valve parts are shown on Page 77B

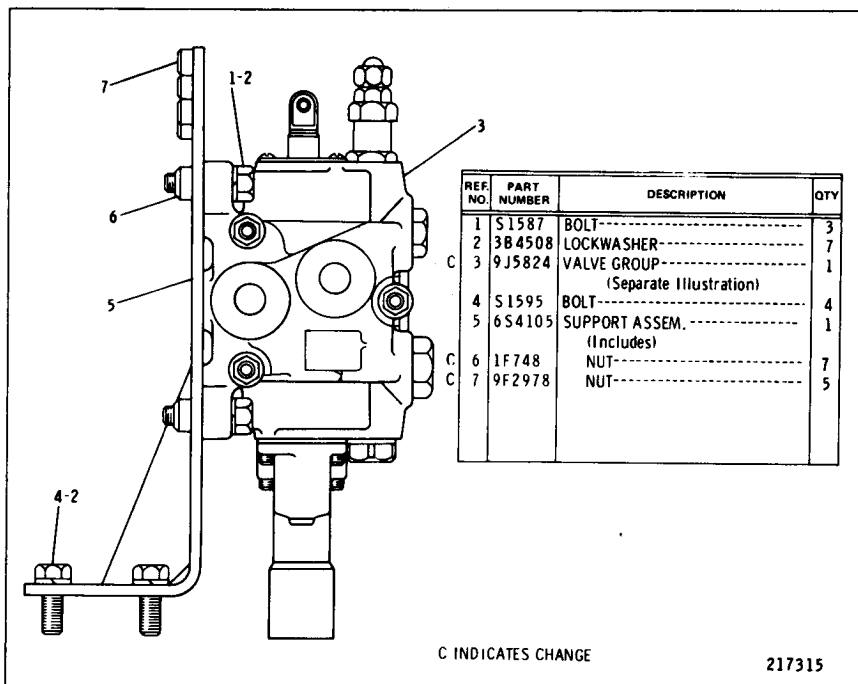

6S4488 CONTROL VALVE GROUP—Type 2  
 Part of 6S3684 Hydraulic Arrangement listed on Page 71  
 9J5824 Valve parts are shown on Page 77A-2

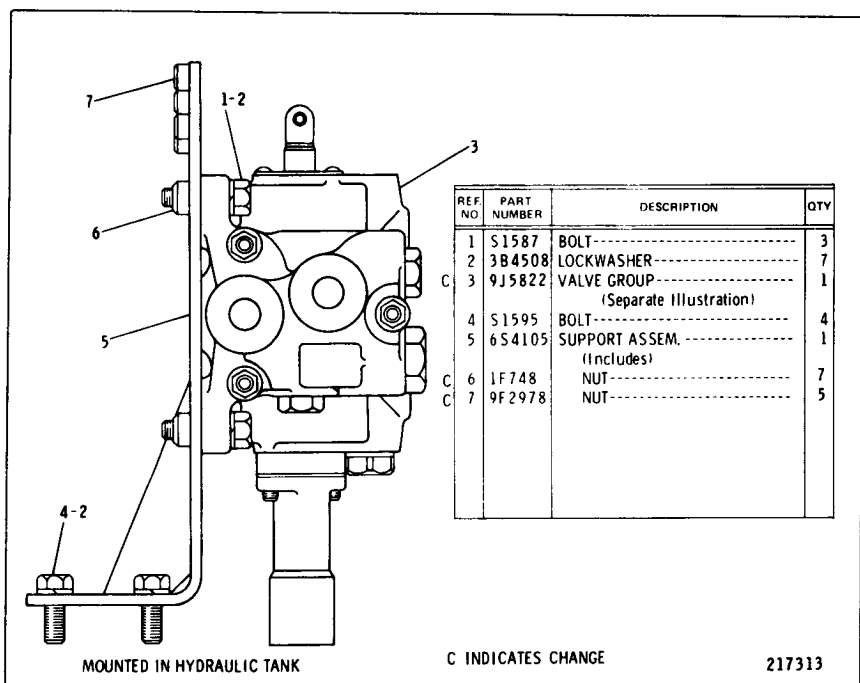

6S3709 CONTROL VALVE GROUP—Type 2  
 Part of 6S3703 Hydraulic Arrangement listed on Page 71  
 9J5822 Valve parts are shown on Page 77A-2



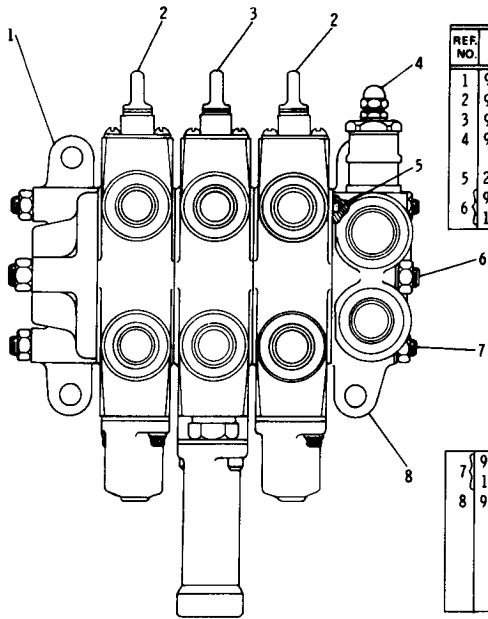

REF. NO.	PART NUMBER	DESCRIPTION	QTY
1	9J721	MANIFOLD-----	1
2	9J718	VALVE GROUP-----	2
3	9J715	VALVE GROUP-----	1
4	9J723	VALVE GROUP----- (Separate Illustration)	1
5	2H4145	SEAL-----	1
6	9J713	ROD-----	1
6	1B4205	NUT-----	2

7	9J703	ROD-----	2
7	1B4204	NUT-----	4
8	9J720	HOUSING-----	1

146032

## 8J4613 BANK VALVE GROUP

REPLACED BY 9J5823. Part of 6S3415 Control Valve Group shown on Page 76  
9J718, 9J723 and 9J715 Valve parts are shown on Pages 77C and 77E

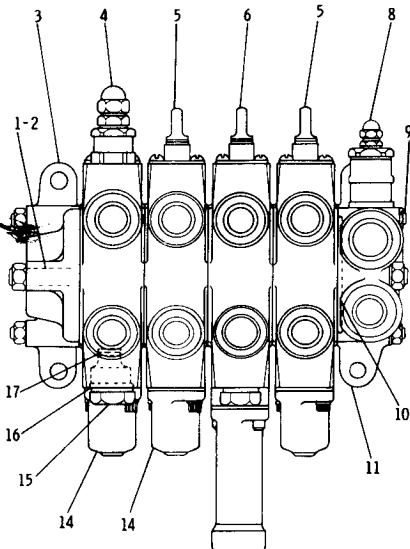

REF. NO.	PART NUMBER	DESCRIPTION	QTY
1	9J714	ROD-----	1
2	1B4205	NUT-----	2
3	9J721	MANIFOLD-----	1
4	9J710	VALVE GROUP-----	1
5	9J718	VALVE GROUP-----	2
6	9J715	VALVE GROUP-----	1
8	9J723	VALVE GROUP----- (Separate Illustration)	1
9	9J704	ROD-----	2
9	1B4204	NUT-----	4
10	2H4145	SEAL-----	1
11	9J720	HOUSING-----	1
14	9J717	VALVE GROUP----- (Separate Illustration)	1
15	9J709	PLUG ASSEM.-----	1
16	3D2824	SEAL-----	1
17	9J1272	RING-----	1
17	4J5309	SEAL-----	1

146035

## 8J4615 BANK VALVE GROUP

REPLACED BY 9J5825. Part of 6S3619 Control Valve Group shown on Page 76  
9J718, 9J723, 9J710, 9J717 and 9J715 Valve parts are shown on Pages 77C,  
77D and 77E

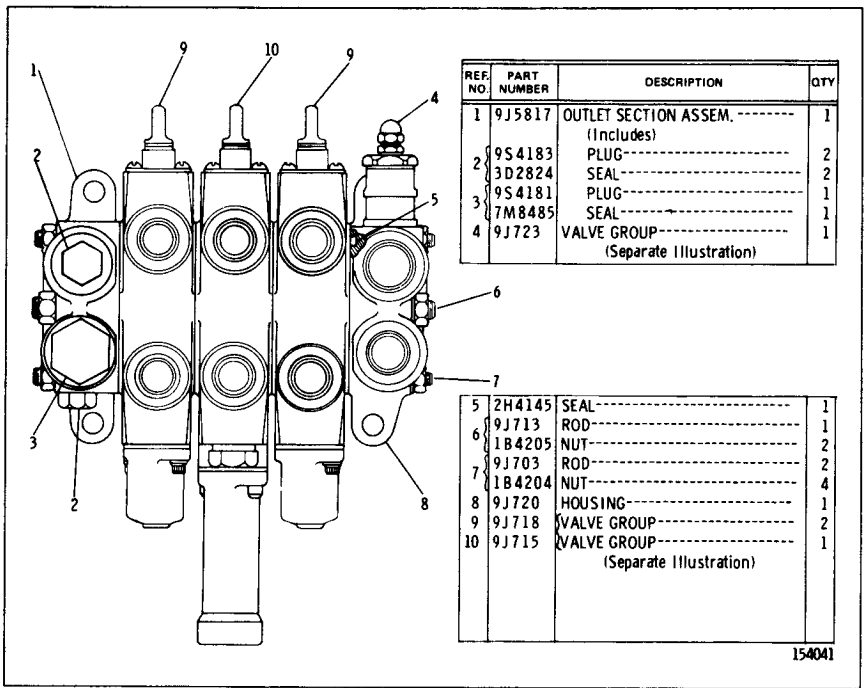

154041

**9J5823 BANK VALVE GROUP**  
 Part of 6S3415 Control Valve Group shown on Page 76A  
 9J718, 9J723 and 9J715 Valve parts are shown on Pages 77C and 77E

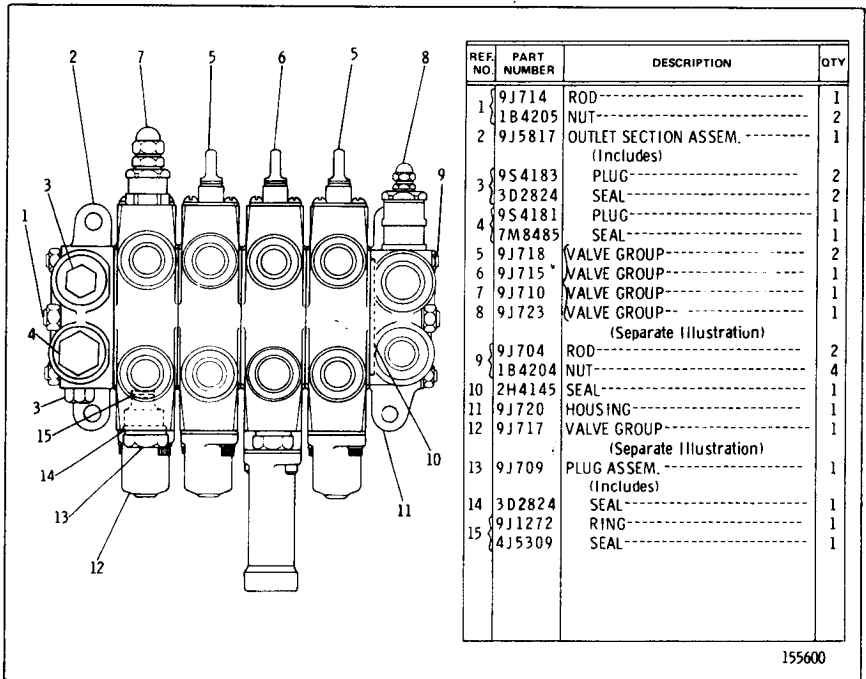

155600

**9J5825 BANK VALVE GROUP**  
 Part of 6S3619 Control Valve Group shown on Page 76A  
 9J718, 9J723, 9J710, 9J717 and 9J715 Valve parts are shown on Pages 77C, 77D and 77E

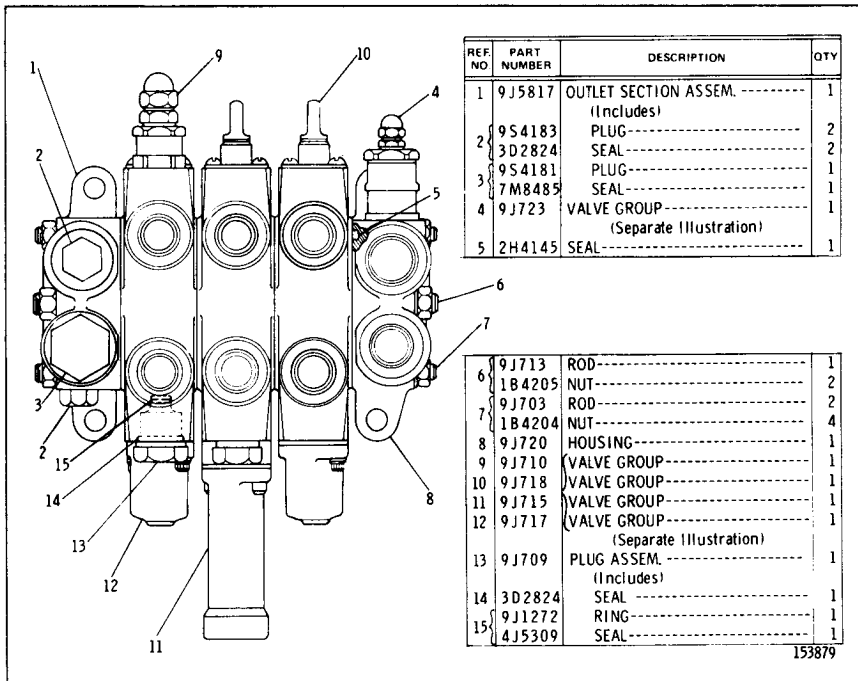

### 9J5824 BANK VALVE GROUP

Part of 6S4488 Control Valve Group shown on Page 77. 9J718, 9J723, 9J710, 9J717 and 9J715 Valve parts are shown on Pages 77C, 77D and 77E

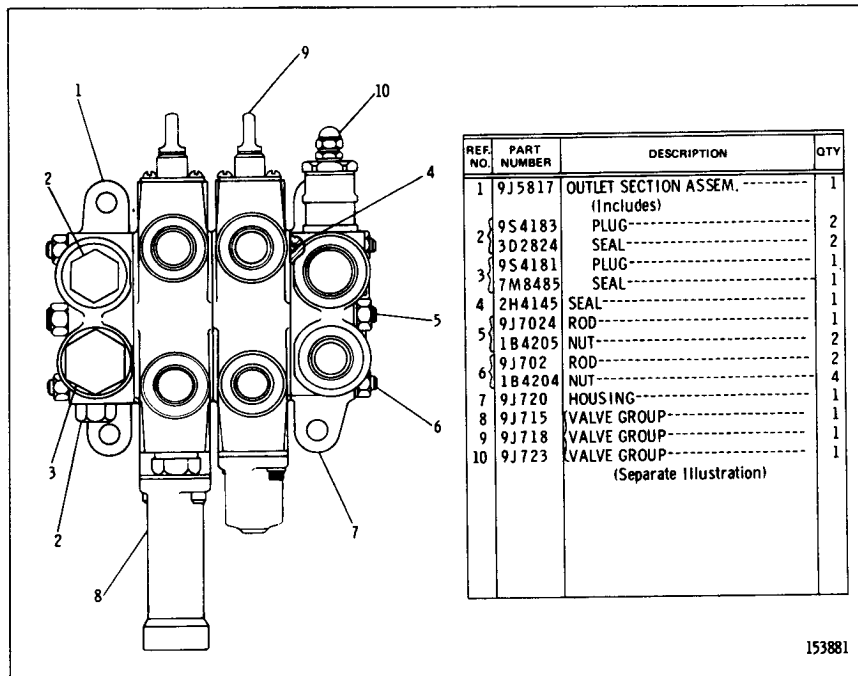

### 9J5822 BANK VALVE GROUP

Part of 6S3709 Control Valve Group shown on Page 77  
9J718, 9J723 and 9J715 Valve parts are shown on Pages 77C and 77E

8J4614 BANK VALVE GROUP

REPLACED BY 9J5824 SHOWN ON PAGE 77A-2. Part of 6S4488 Control Valve Group shown on Page 76B, 9J718, 9J723, 9J710, 9J717 and 9J715 Valve parts are shown on Pages 77C, 77D and 77E

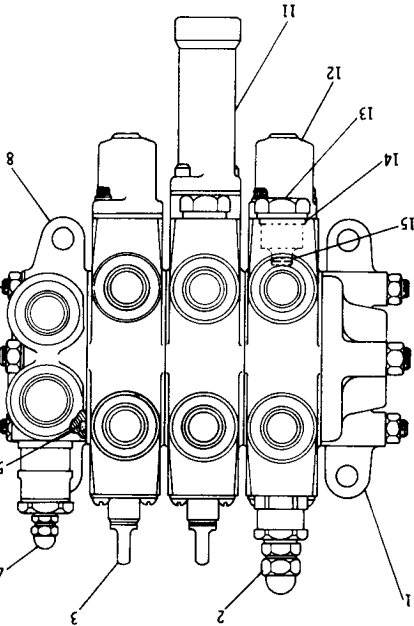

REF NO	PART NUMBER	DESCRIPTION	QTY
1	9J721	MANIFOLD	1
2	9J710	VALVE GROUP	1
3	9J718	VALVE GROUP	1
4	9J723	VALVE GROUP	1
5	2H4145	SEAL (Separate Illustration)	1
6	9J713	ROD	1
7	1B4205	NUT	2
8	9J720	HOUSING	4
9	9J715	VALVE GROUP	1
10	9J717	VALVE GROUP	1
11	9J715	VALVE GROUP	1
12	9J717	VALVE GROUP	1
13	9J709	PLUG ASSEM. (Separate Illustration)	1
14	3O2824	SEAL	1
15	9J1272	RING	1
	4J5309	SEAL	1

146039

8J4612 BANK VALVE GROUP

REPLACED BY 9J5822 SHOWN ON PAGE 77A-2. Part of 6S3709 Control Valve Group shown on Page 76B, 9J718, 9J723, 9J715 Valve parts are shown on Pages 77C and 77E

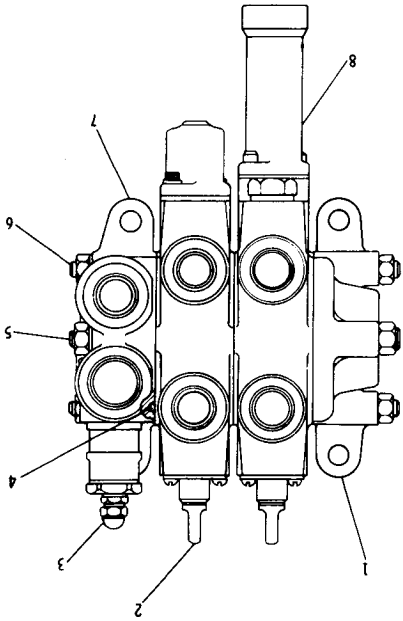

REF NO	PART NUMBER	DESCRIPTION	QTY
1	9J721	MANIFOLD	1
2	9J718	VALVE GROUP	1
3	9J723	VALVE GROUP	1
4	2H4145	SEAL (Separate Illustration)	1
5	5K2933	ROD	1
6	1B4205	NUT	2
7	9J720	HOUSING	4
8	9J715	VALVE GROUP	1

146037

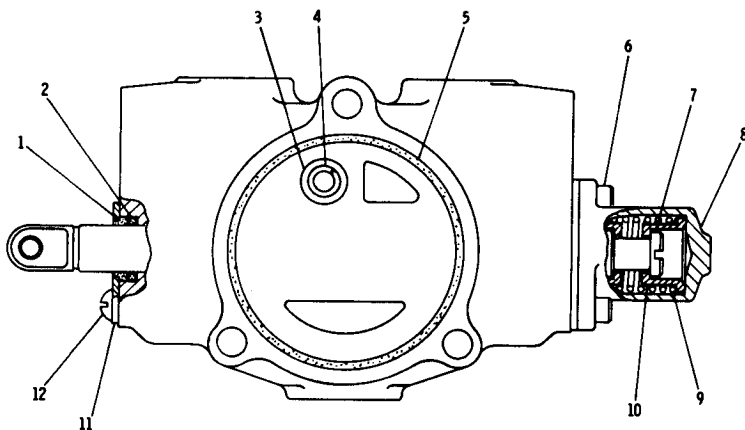

REF. NO.	PART NUMBER	DESCRIPTION	QTY
1	329805	SEAL-----	2
2	5F7054	SEAL-----	2
3	8J9464	POPPET-----	1
4	8J9463	SPRING-----	1
5	2H4145	SEAL-----	1
6	6L5897	BOLT-----	2

7	58145	SCREW-----	1
8	58141	CAP-----	1
9	58146	SPRING-----	1
10	58144	SEAL-----	2
11	58143	PLATE-----	2
12	8F5758	SCREW-----	2

146033

## 9J718 CONTROL VALVE GROUP

Part of 8J4613, 8J4615, 9J5823, 9J5825, 9J5824, 9J5822, 8J4614 & 8J4612  
Bank Valve Groups shown on Pages 77A, 77A-1, 77A-2 & 77B

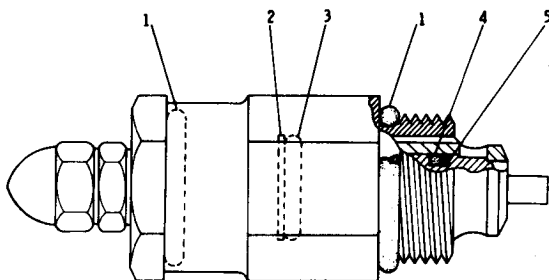

REF. NO.	PART NUMBER	DESCRIPTION	QTY
1	3D2824	SEAL-----	2
2	9J707	RING-----	1
3	6F4855	SEAL-----	1

C 4	1H1023	SEAL-----	1
5	300167	RING-----	1

C INDICATES CHANGE

119637

## 9J723 RELIEF VALVE GROUP—Pilot Operated

Part of 8J4613, 8J4615, 9J5823, 9J5825, 9J5824, 9J5822, 8J4614 & 8J4612  
Bank Valve Groups shown on Pages 77A, 77A-1, 77A-2 and 77B

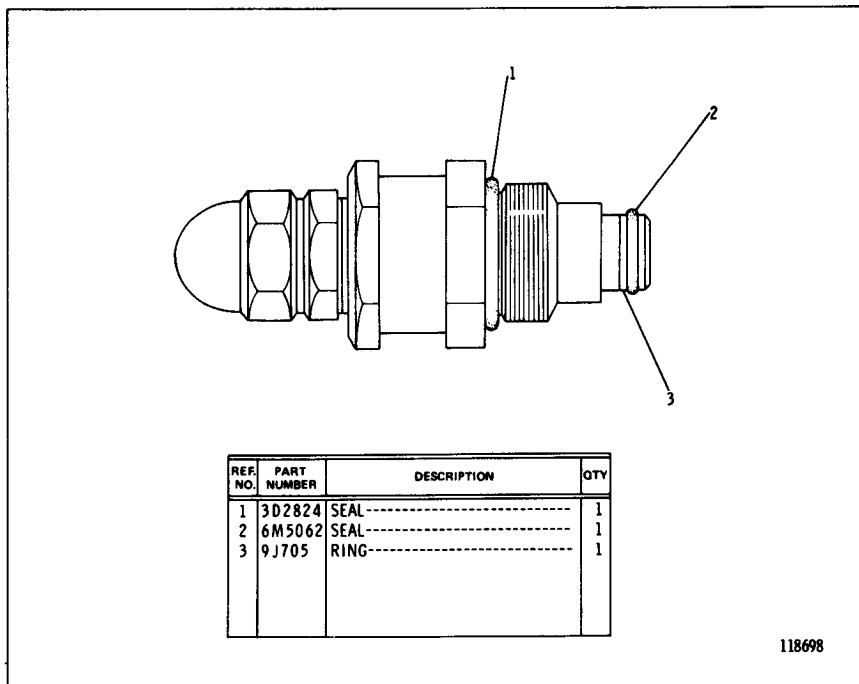

REF. NO.	PART NUMBER	DESCRIPTION	QTY
1	3D2824	SEAL-----	1
2	6M5062	SEAL-----	1
3	9J705	RING-----	1

118698

**9J710 RELIEF VALVE GROUP—Direct Operated**  
 Part of 8J4615, 9J5825, 9J5824, 9J5822 & 9J4614 Bank Valve Groups  
 shown on Pages 77A, 77A-1, 77A-2 & 77B

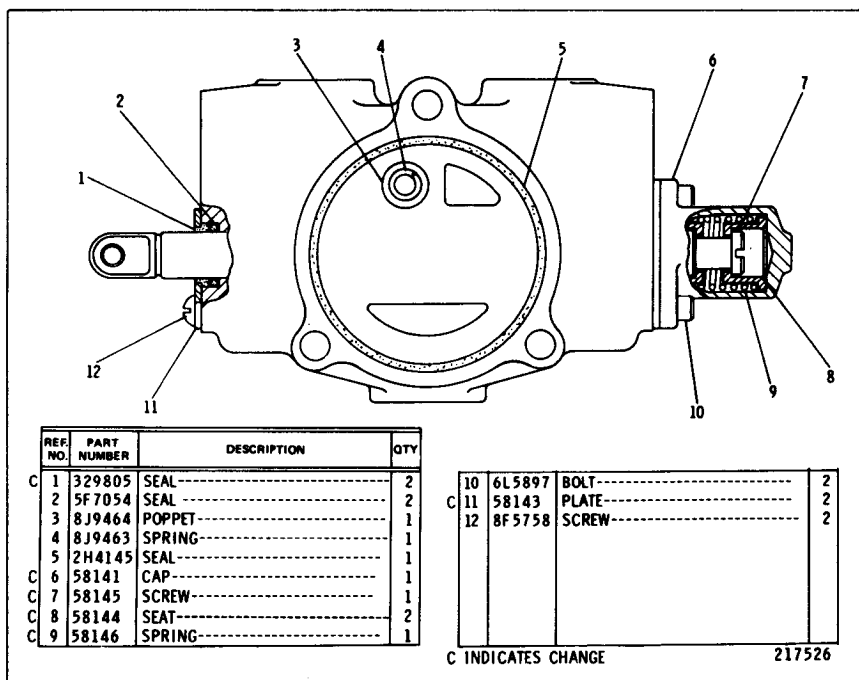

REF. NO.	PART NUMBER	DESCRIPTION	QTY
C 1	329805	SEAL-----	2
2	5F7054	SEAL-----	2
3	8J9464	POPPET-----	1
4	8J9463	SPRING-----	1
5	2H4145	SEAL-----	1
C 6	58141	CAP-----	1
C 7	58145	SCREW-----	1
C 8	58144	SEAT-----	2
C 9	58146	SPRING-----	1

10	6L5897	BOLT-----	2
C 11	58143	PLATE-----	2
12	8F5758	SCREW-----	2

C INDICATES CHANGE

217526

**9J717 CONTROL VALVE GROUP**  
 Part of 8J4615, 9J5825, 9J5824 and 8J4614 Bank Valve Groups  
 shown on Pages 77A, 77A-1, 77A-2 and 77B

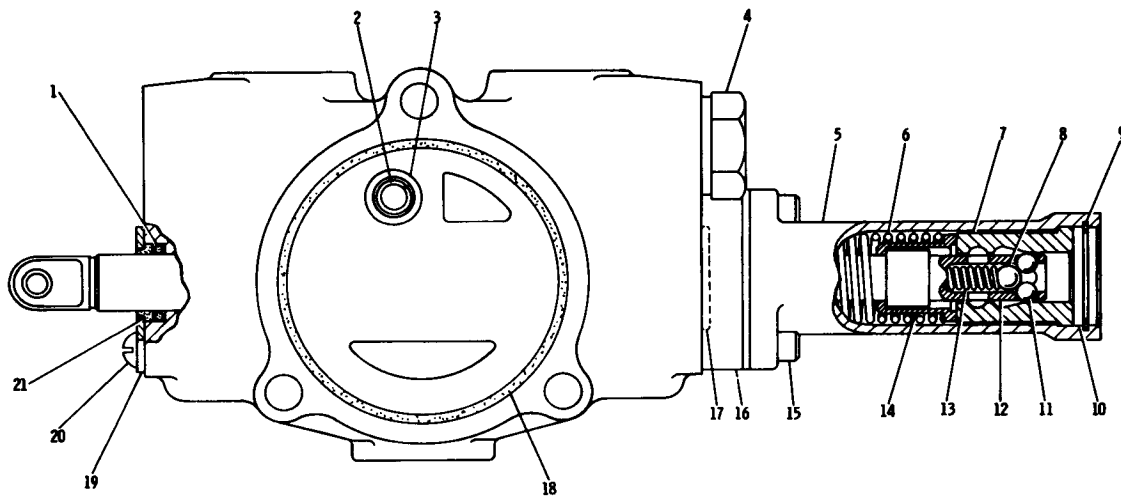

REF. NO.	PART NUMBER	DESCRIPTION	QTY
1	5F7054	SEAL-----	2
2	8J9463	SPRING-----	1
3	8J9464	POPPET-----	1
4	8J9471	CHECK VALVE GROUP----- (Separate Illustration)	1
5	8J9472	CAP-----	1
6	8J9466	SPRING-----	1
7	8J9476	SLEEVE-----	1

8	8J4455	BALL-----	1
9	9J706	RING-----	1
10	8J9462	PLUG-----	1
11	2D6642	BALL-----	4
12	8J9459	PIN-----	1
13	8J9465	SPRING-----	1
14	8J9468	RETAINER-----	2
15	4L7124	BOLT-----	2
16	8J9474	SPACER-----	1
17	4F8946	SEAL-----	1

	18	2H4145	SEAL-----	1
C	19	58143	PLATE-----	2
	20	8F5758	SCREW-----	2
C	21	329805	SEAL-----	2

C INDICATES CHANGE

214116

## 9J715 CONTROL VALVE GROUP

Part of 8J4613, 8J4615, 9J5823, 9J5825, 9J5824, 9J5822, 8J4614 and 8J4612  
Bank Valve Groups shown on Pages 77A, 77A-1, 77A-2 and 77B

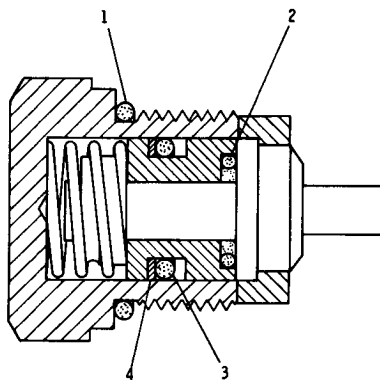

REF. NO.	PART NUMBER	DESCRIPTION	QTY
1	3D2824	SEAL-----	1
2	6M5062	SEAL-----	1

3	6F4855	SEAL-----	1
4	9J707	RING-----	1

144424

8J9471 CHECK VALVE GROUP  
Part of 9J715 Control Valve Group



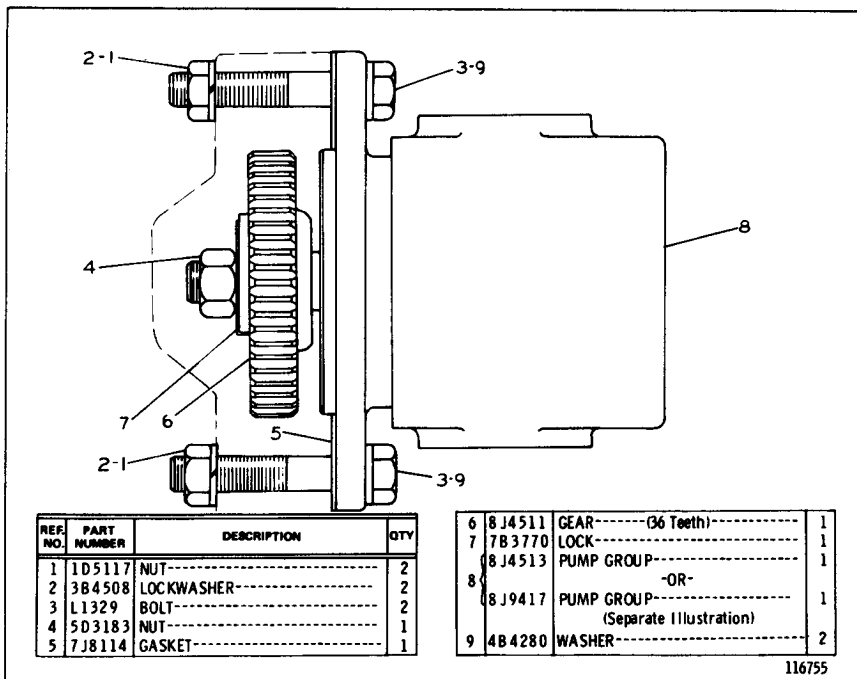

## 8J4512 GEAR PUMP GROUP—Type 1

Part of 6S3413, 6S3618, 6S3684 & 6S3703 Hydraulic Arrangements listed on Page 71  
8J4513 & 8J9417 Pump parts are shown on Page 78A. AN ATTACHMENT

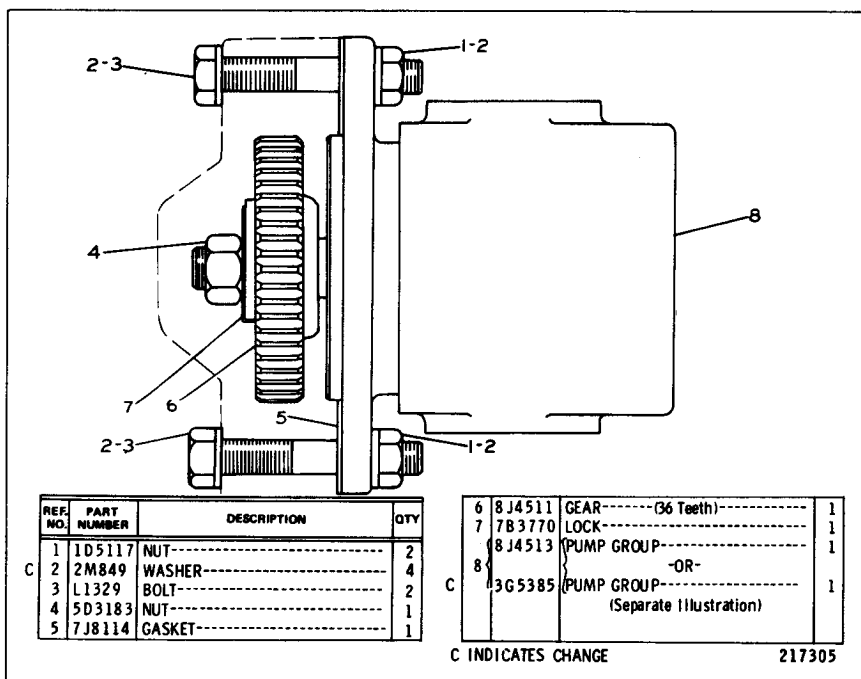

## 8J4512 GEAR PUMP GROUP—Type 2

Part of 6S3413, 6S3618, 6S3684 & 6S3703 Hydraulic Arrangements listed on Page 71  
8J4513 and 3G5385 Pump parts are shown on Pages 78A & 78B  
AN ATTACHMENT

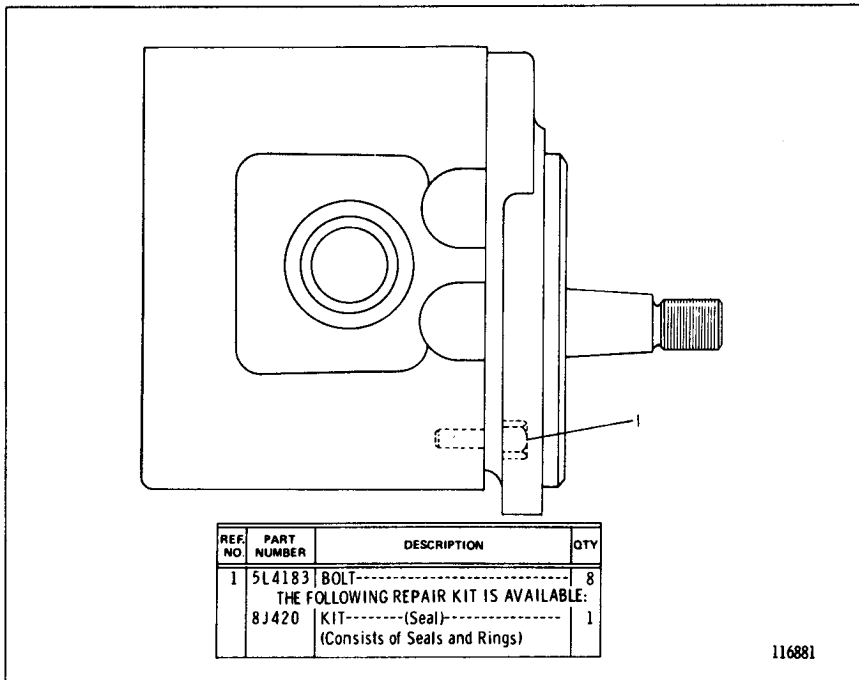

8J4513 GEAR PUMP GROUP  
Part of 8J4512 Gear Pump Group shown on Page 78  
AN ATTACHMENT

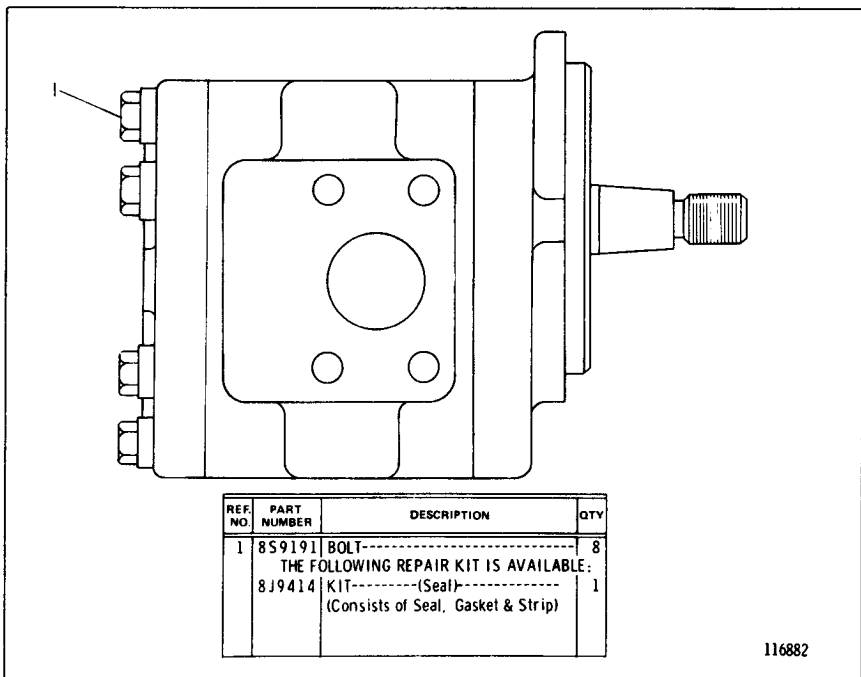

8J9417 GEAR PUMP GROUP—Replaced by 3G5385 shown on Page 78B  
Part of 8J4512 Gear Pump Group shown on Page 78  
AN ATTACHMENT

CATERPILLAR D3 TRACTOR

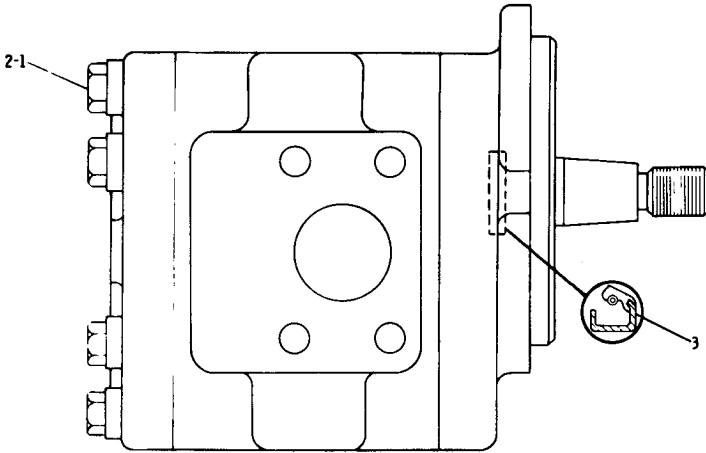

REF NO	PART NUMBER	DESCRIPTION	QTY
1	8S9191	BOLT-----	8
2	5M2894	WASHER-----	8
3	3G5083	SEAL-----	1

THE FOLLOWING REPAIR KIT IS AVAILABLE:  
 3G5858 KIT----- (seal)----- 1  
 (Consists of Seal, Gasket & Strip)

217306

3G5385 GEAR PUMP GROUP  
 Part of 8J4512 Gear Pump Group shown on Page 78

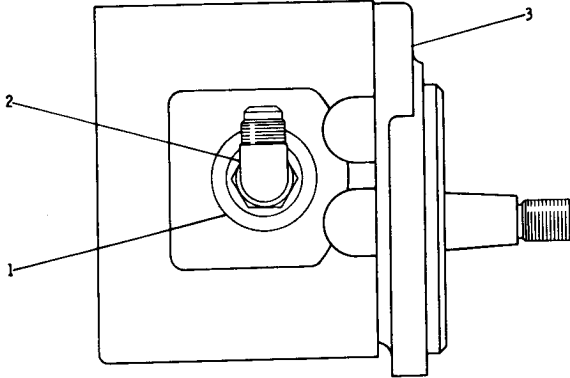

REF NO	PART NUMBER	DESCRIPTION	QTY
1	7M8485	SEAL-----	1
2	307951	FITTING-----	1
3	8J4515	GEAR PUMP GROUP-----	1
	8J9416	GEAR PUMP GROUP----- (Separate Illustration)	1

118645

6S7784 GEAR PUMP GROUP—Type 1  
 8J9416 and 8J4515 Pump parts are shown on Pages 79 and 79B  
 AN ATTACHMENT

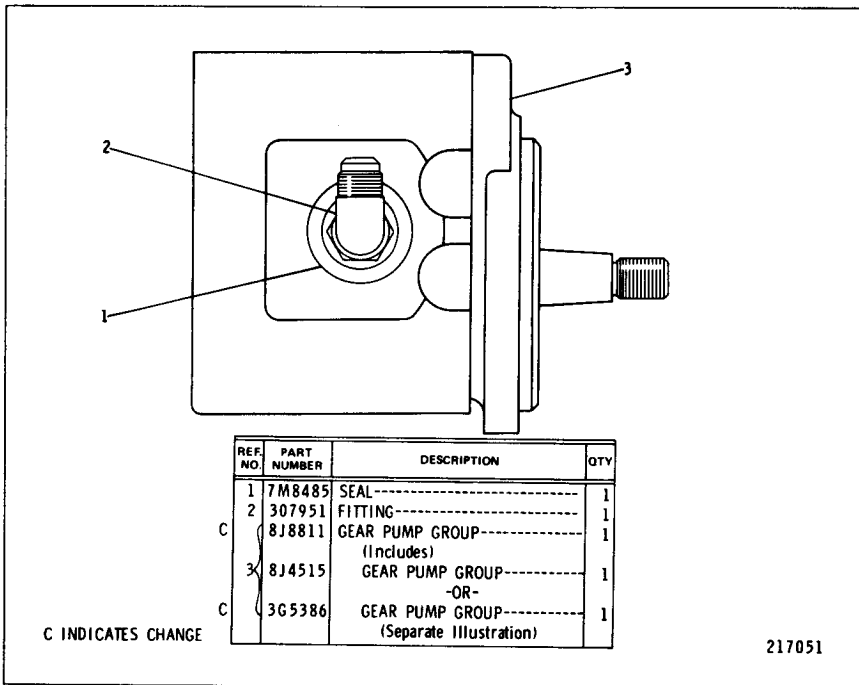

6S7784 GEAR PUMP GROUP—Type 2  
8J4515 and 3G5386 Pump parts are shown on Page 79B

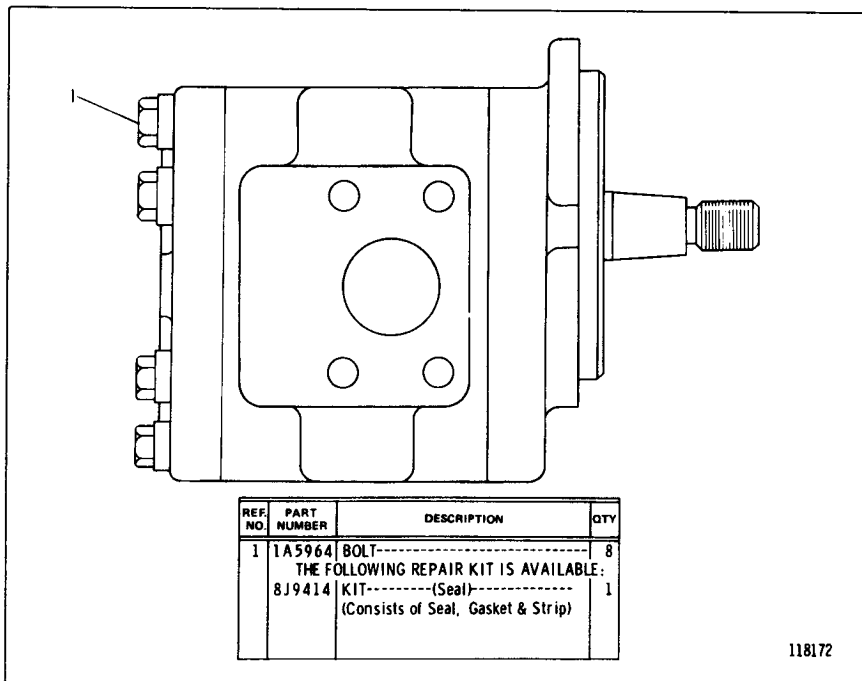

8J9416 GEAR PUMP GROUP—Replaced by 3G5386 shown on Page 79B  
Part of 6S7784 Gear Pump Group shown on Page 78B

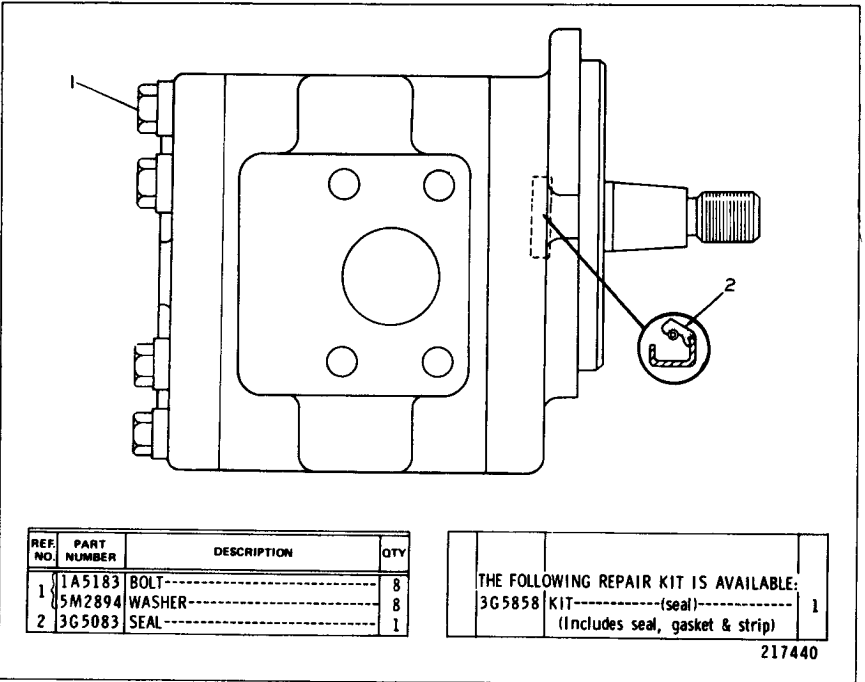

3G5386 GEAR PUMP GROUP  
Part of 6S7784 Gear Pump Group shown on Page 79

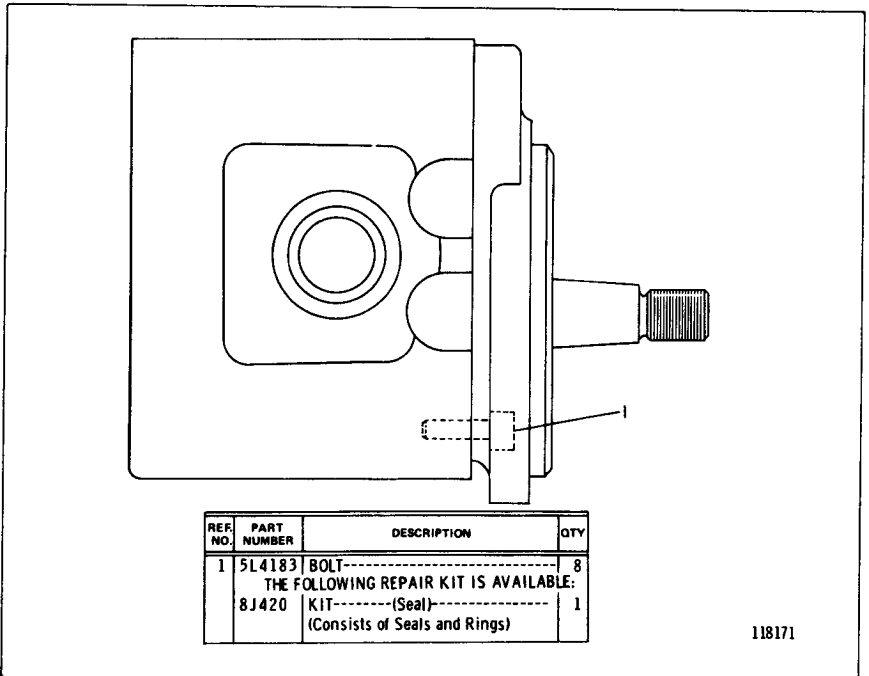

8J4515 GEAR PUMP GROUP  
Part of 6S7784 Gear Pump Group shown on Pages 78B and 79

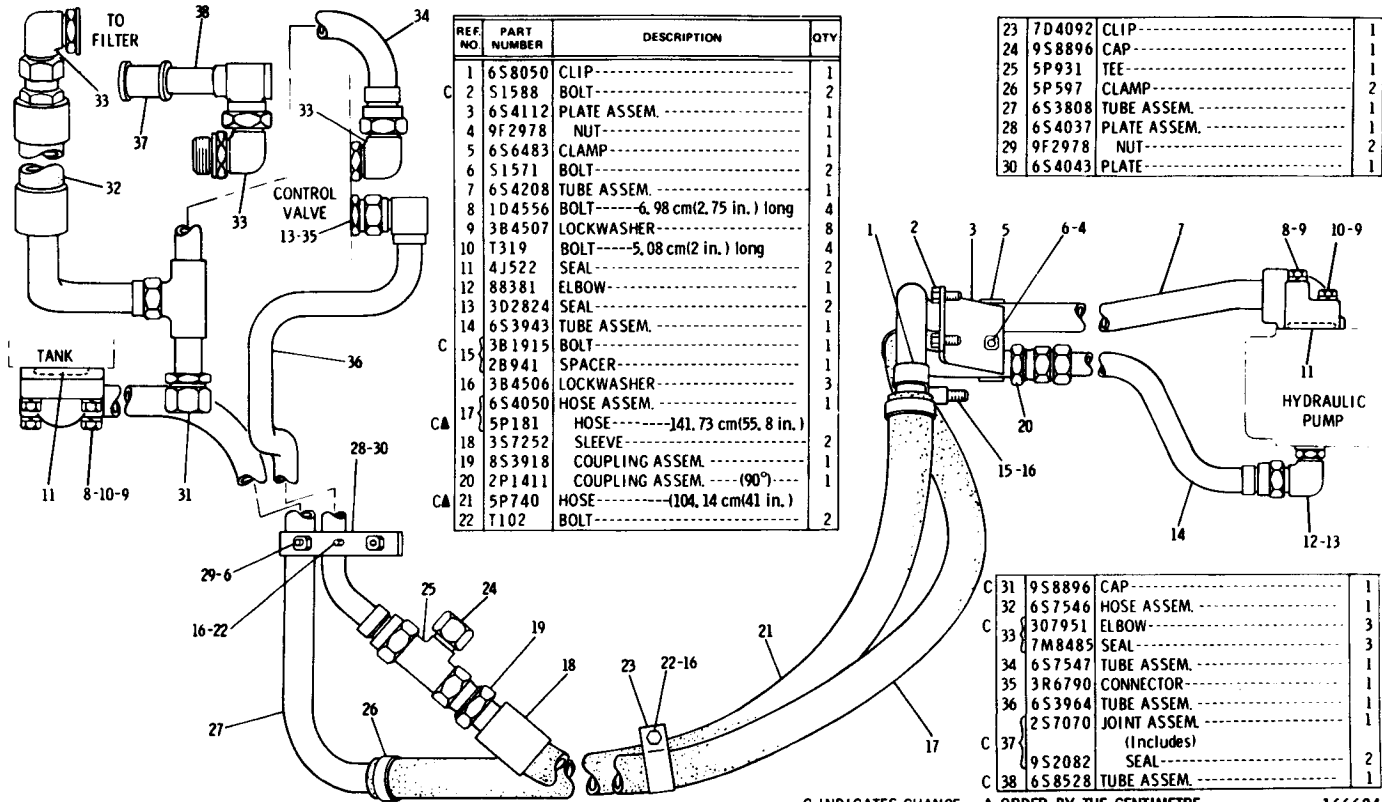

C INDICATES CHANGE

▲ ORDER BY THE CENTIMETRE

166694

## 6S3418 PUMP LINES GROUP—Type 1

Part of 6S3413, 6S3618, 6S3684 and 6S3703 Hydraulic Arrangements listed on Page 71

6S3418 PUMP LINES GROUP—Type 2  
 Part of 6S3413, 6S3618, 6S3684 and 6S3703 Hydraulic Arrangements listed on Page 71

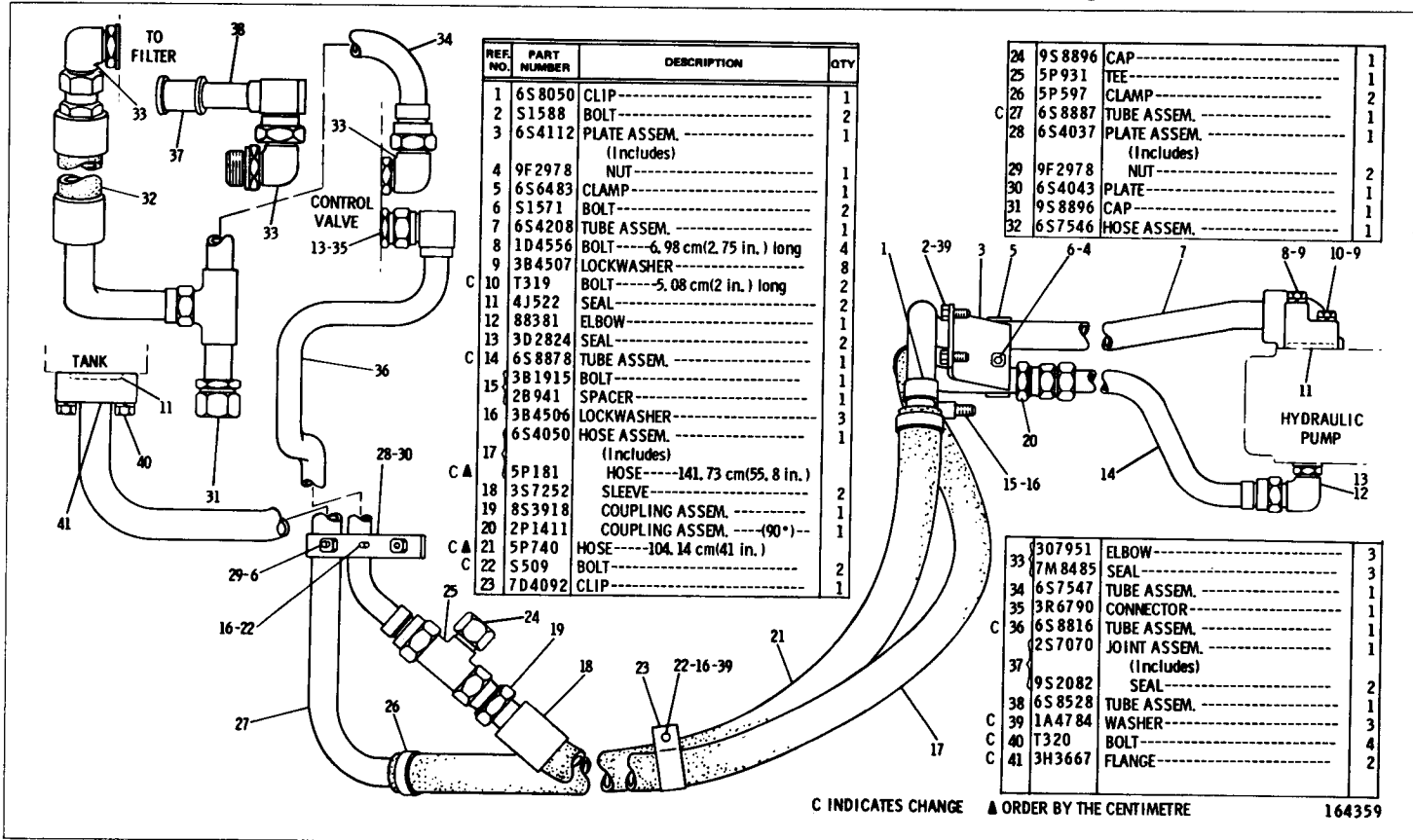

REF. NO.	PART NUMBER	DESCRIPTION	QTY
1	6S 8050	CLIP-----	1
2	S1588	BOLT-----	2
3	6S4112	PLATE ASSEM.----- (Includes)	1
4	9F 2978	NUT-----	1
5	6S 6483	CLAMP-----	1
6	S1571	BOLT-----	2
7	6S 4208	TUBE ASSEM.-----	1
8	1D 4556	BOLT----6.98 cm(2.75 in.) long	4
9	3B 4507	LOCKWASHER-----	8
10	T319	BOLT----5.08 cm(2 in.) long	2
11	4J522	SEAL-----	2
12	88381	ELBOW-----	1
13	3D 2824	SEAL-----	2
14	6S 8878	TUBE ASSEM.-----	1
15	3B 1915	BOLT-----	1
16	2B 941	SPACER-----	1
17	3B 4506	LOCKWASHER-----	3
18	6S 4050	HOSE ASSEM.----- (Includes)	1
19	5P 181	HOSE----141.73 cm(55.8 in.)	2
20	3S 7252	SLEEVE-----	1
21	8S 3918	COUPLING ASSEM.-----	1
22	2P 1411	COUPLING ASSEM.---(90°)---	1
23	5P 740	HOSE----104.14 cm(41 in.)	2
24	S 509	BOLT-----	2
25	7D 4092	CLIP-----	1

26	9S 8896	CAP-----	1
27	5P 931	TEE-----	1
28	5P 597	CLAMP-----	2
29	6S 8887	TUBE ASSEM.-----	1
30	6S 4037	PLATE ASSEM.----- (Includes)	1
31	9F 2978	NUT-----	2
32	6S 4043	PLATE-----	1
33	9S 8896	CAP-----	1
34	6S 7546	HOSE ASSEM.-----	1

35	307951	ELBOW-----	3
36	7M 8485	SEAL-----	3
37	6S 7547	TUBE ASSEM.-----	1
38	3R 6790	CONNECTOR-----	1
39	6S 8816	TUBE ASSEM.-----	1
40	2S 7070	JOINT ASSEM.----- (Includes)	1
41	9S 2082	SEAL-----	2
42	6S 8528	TUBE ASSEM.-----	1
43	1A 4784	WASHER-----	3
44	T 320	BOLT-----	4
45	3H 3667	FLANGE-----	2

C INDICATES CHANGE    ▲ ORDER BY THE CENTIMETRE    164359

HYDRAULIC SYSTEM

80A

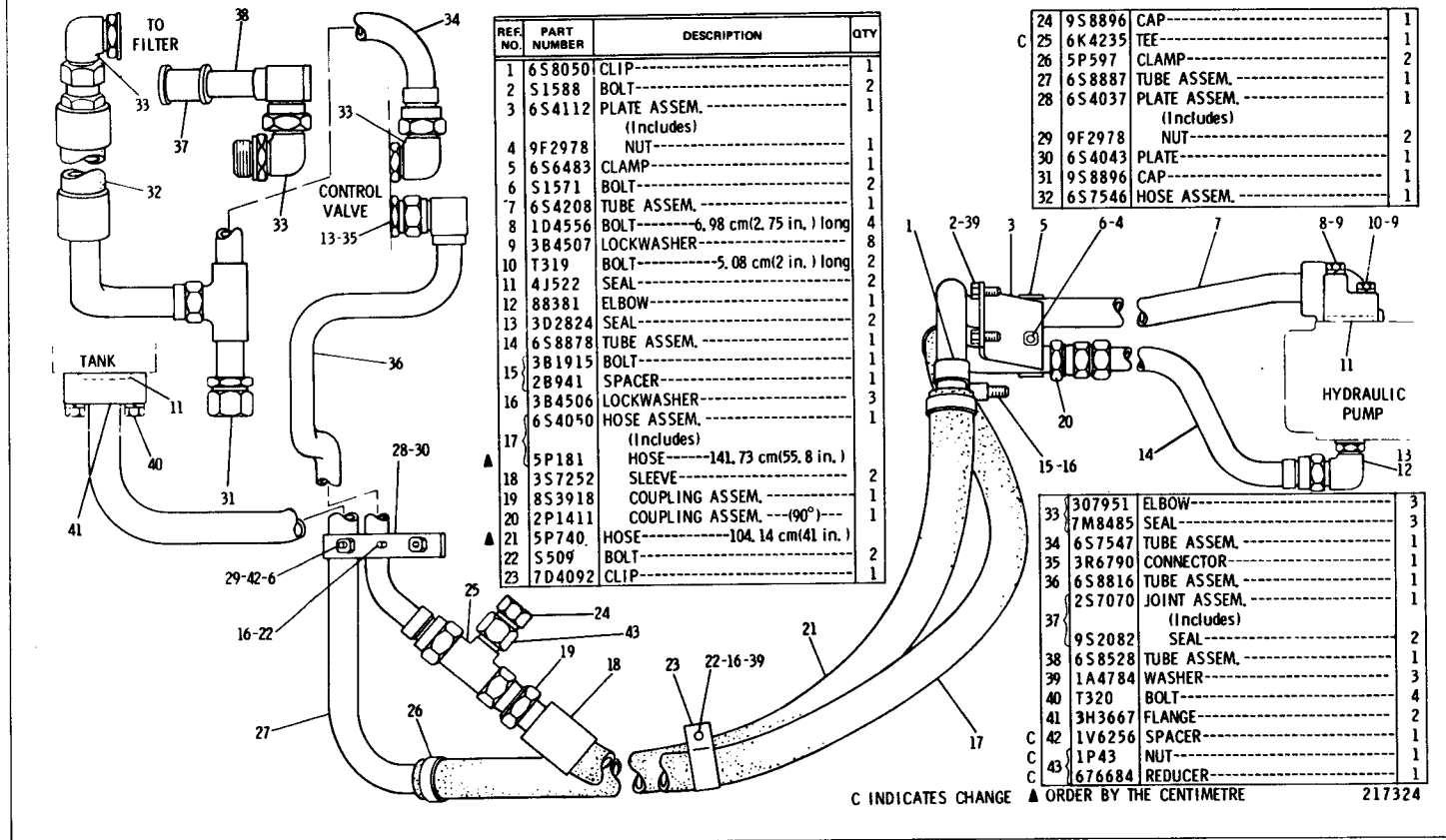

6S3418 PUMP LINES GROUP—Type 3

Part of 6S3413, 6S3618, 6S3684 and 6S3703 Hydraulic Arrangements listed on Page 71



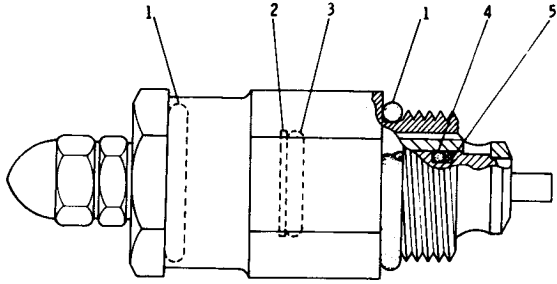

REF NO	PART NUMBER	DESCRIPTION	QTY
1	3D2824	SEAL-----	2
2	9J707	RING-----	1
3	6F4855	SEAL-----	1

4	1H1023	SEAL-----	1
5	300167	RING-----	1

118954

9J798 RELIEF VALVE GROUP—Pilot Operated—3000 PSI  
 Part of 5G1177 Lines and Pump Group shown on Page 80D

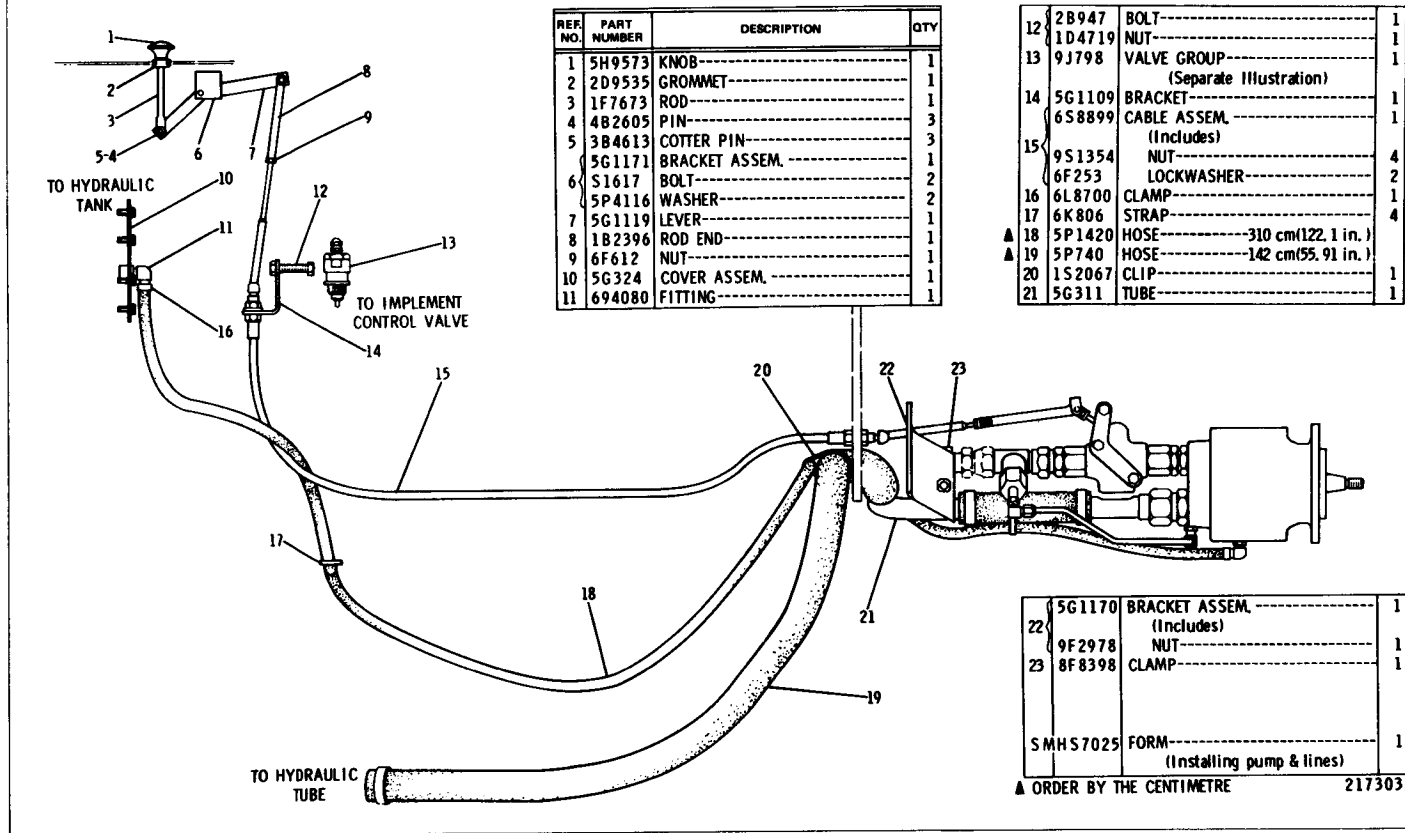

5G1177 LINES AND PUMP GROUP—Part 1  
9J798 Valve parts are shown on Page 80C  
AN ATTACHMENT

5G1177 LINES AND PUMP GROUP—Part 2  
 3G4096 Pump parts are shown on Page 80F  
 AN ATTACHMENT

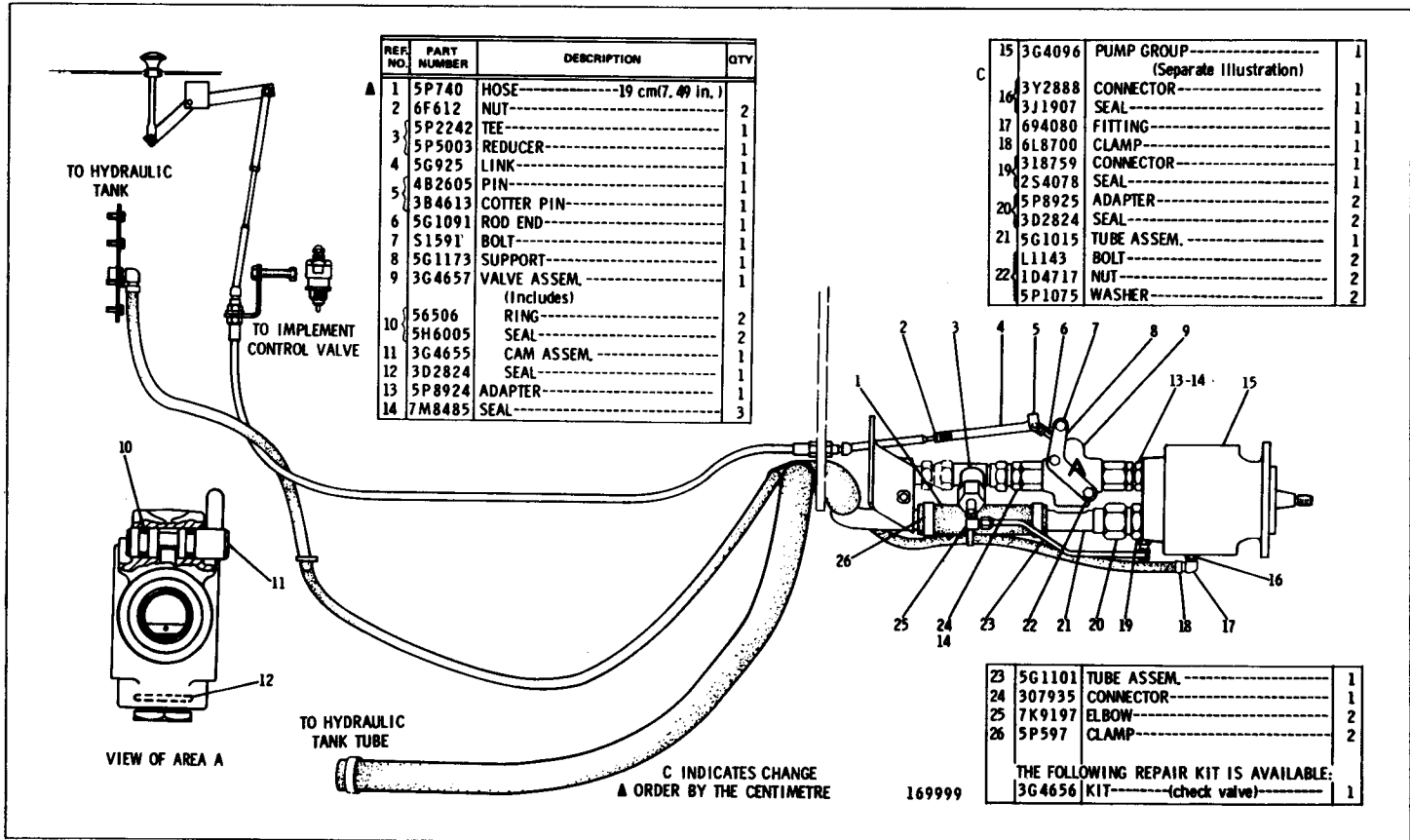

REF. NO.	PART NUMBER	DESCRIPTION	QTY
1	5P740	HOSE-----19 cm(7.49 in.)	2
2	6F612	NUT-----	1
3	5P2242	TEE-----	1
3	5P5003	REDUCER-----	1
4	5G925	LINK-----	1
5	4B2605	PIN-----	1
5	3B4613	COTTER PIN-----	1
6	5G1091	ROD END-----	1
7	S1591	BOLT-----	1
8	5G1173	SUPPORT-----	1
9	3G4657	VALVE ASSEM. (Includes)	1
10	56506	RING-----	2
10	5H6005	SEAL-----	2
11	3G4655	CAM ASSEM.	1
12	3D2824	SEAL-----	1
13	5P8924	ADAPTER-----	1
14	7M8485	SEAL-----	3

15	3G4096	PUMP GROUP----- (Separate Illustration)	1
16	3Y2888	CONNECTOR-----	1
16	3J1907	SEAL-----	1
17	694080	FITTING-----	1
18	6L8700	CLAMP-----	1
19	318759	CONNECTOR-----	1
19	2S4078	SEAL-----	1
20	5P8925	ADAPTER-----	2
20	3D2824	SEAL-----	2
21	5G1015	TUBE ASSEM.	1
22	L1143	BOLT-----	2
22	1D4717	NUT-----	2
22	5P1075	WASHER-----	2

23	5G1101	TUBE ASSEM.	1
24	307935	CONNECTOR-----	1
25	7K9197	ELBOW-----	2
26	5P597	CLAMP-----	2
THE FOLLOWING REPAIR KIT IS AVAILABLE:			
3G4656	KIT-----	(check valve)	1

C INDICATES CHANGE  
 ▲ ORDER BY THE CENTIMETRE

169999

HYDRAULIC SYSTEM

80E

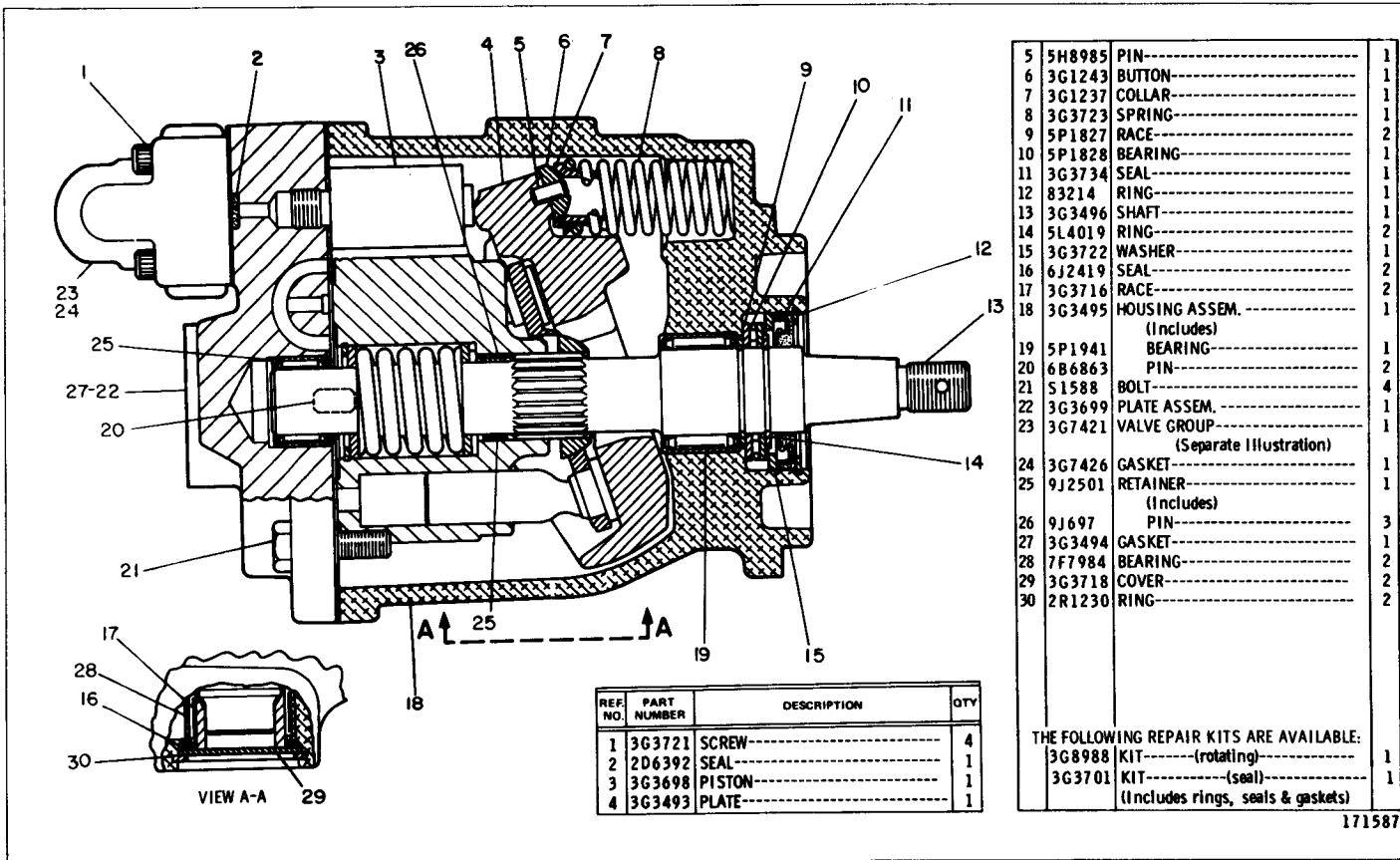

REF. NO.	PART NUMBER	DESCRIPTION	QTY
1	3G3721	SCREW-----	4
2	2D6392	SEAL-----	1
3	3G3698	PISTON-----	1
4	3G3493	PLATE-----	1

5	5H8985	PIN-----	1
6	3G1243	BUTTON-----	1
7	3G1237	COLLAR-----	1
8	3G3723	SPRING-----	1
9	5P1827	RACE-----	2
10	5P1828	BEARING-----	1
11	3G3734	SEAL-----	1
12	83214	RING-----	1
13	3G3496	SHAFT-----	1
14	5L4019	RING-----	2
15	3G3722	WASHER-----	1
16	6J2419	SEAL-----	2
17	3G3716	RACE-----	2
18	3G3495	HOUSING ASSEM. (Includes)	1
19	5P1941	BEARING-----	1
20	6B6863	PIN-----	2
21	S1588	BOLT-----	4
22	3G3699	PLATE ASSEM.	1
23	3G7421	VALVE GROUP (Separate Illustration)	1
24	3G7426	GASKET-----	1
25	9J2501	RETAINER----- (Includes)	1
26	9J697	PIN-----	3
27	3G3494	GASKET-----	1
28	7F7984	BEARING-----	2
29	3G3718	COVER-----	2
30	2R1230	RING-----	2

THE FOLLOWING REPAIR KITS ARE AVAILABLE:  
 3G8988 KIT----- (rotating)----- 1  
 3G3701 KIT----- (seal)----- 1  
 (Includes rings, seals & gaskets)

171587

3G4096 PISTON PUMP GROUP—Slipper  
 Part of 5G1177 Lines and Pump Group shown on Page 80E. 3G7421 Valve parts are shown on Page 80G  
 AN ATTACHMENT

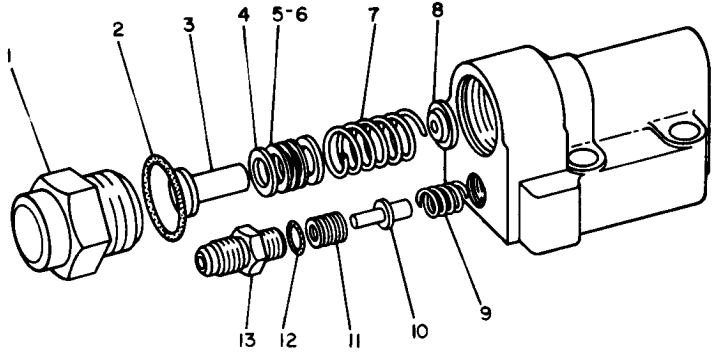

REF. NO.	PART NUMBER	DESCRIPTION	QTY
1	3G5422	CAP-----	1
2	7J9933	SEAL-----	1
3	3G5421	STOP-----	1
4	6L7219	WASHER-----	2
5	3G3697	SHIM----.0762 mm(.003 in.)thick	3
6	6J6516	SHIM----.254 mm(.010 in.) thick	2
7	3G5423	SPRING-----	1
8	3G5424	RETAINER-----	1

9	3G5035	SPRING-----	1
10	3G3732	STOP-----	1
11	3G5039	SHIM---.2032mm (.008 in.) thick	2
	3G5037	SHIM---.1270mm (.005 in.) thick	2
	3G5040	SHIM---.5080mm (.020 in.) thick	2
	3G5038	SHIM---.1524mm (.006 in.) thick	1
12	5P7813	SEAL-----	1
13	3G7409	CONNECTOR-----	1

170001

3G7421 SERVO VALVE GROUP  
 Part of 3G4096 Piston Pump Group shown on Page 80F  
 AN ATTACHMENT

6S4107 REAR LINES GROUP  
 Part of 6S3618 Hydraulic Arrangement listed on Page 71

REF. NO.	PART NUMBER	DESCRIPTION	QTY
1	6S4340	PLATE-----	1
2	S509	BOLT-----	4
3	1D4717	NUT-----	5
4	3B4506	LOCKWASHER-----	6
5	7F2060	NUT-----	2
6	6S7308	TUBE ASSEM.-----	2
7	6S7378	CLAMP ASSEM.-----	1
8	9F2978	NUT-----	1
9	6S7366	BRACKET-----	1
10	L1351	BOLT-----	2

11	6S7309	TUBE ASSEM.-----	1
12	6S7305	TUBE ASSEM.-----	1
13	308190	CONNECTOR-----	2
13	302824	SEAL-----	2
C 14	6J7366	CAP-----	2

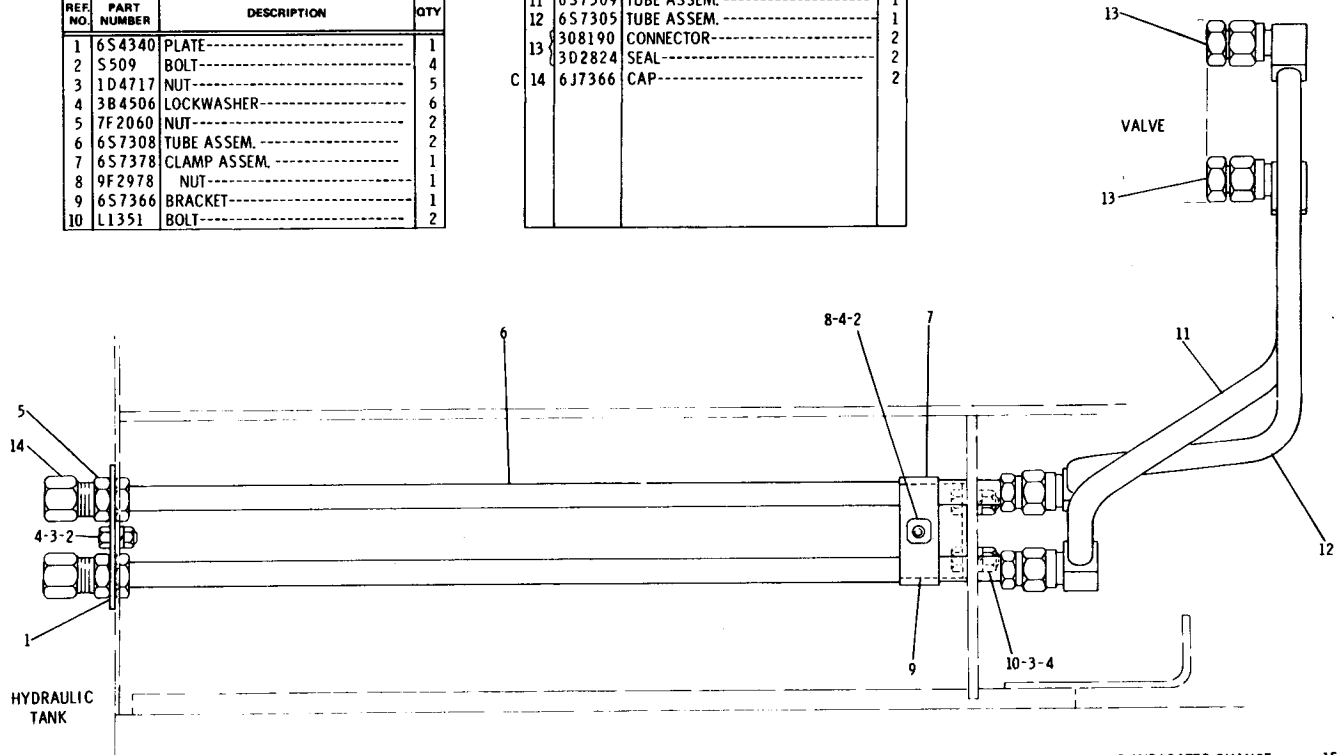

C INDICATES CHANGE

154507

HYDRAULIC SYSTEM

REF. NO.	PART NUMBER	DESCRIPTION	QTY
1	6S4340	PLATE-----	1
2	S509	BOLT-----	4
3	1D4717	NUT-----	5
4	3B4506	LOCKWASHER-----	6
5	7F2060	NUT-----	2
6	6S7308	TUBE ASSEM.-----	2
7	6S7378	CLAMP ASSEM.-----	1
8	9F2978	NUT-----	1
9	6S7366	BRACKET-----	1
10	L1351	BOLT-----	2

11	6S7306	TUBE ASSEM.-----	1
12	6S7307	TUBE ASSEM.-----	1
13	308190	CONNECTOR-----	2
	3D2824	SEAL-----	2
C 14	6J7366	CAP-----	2

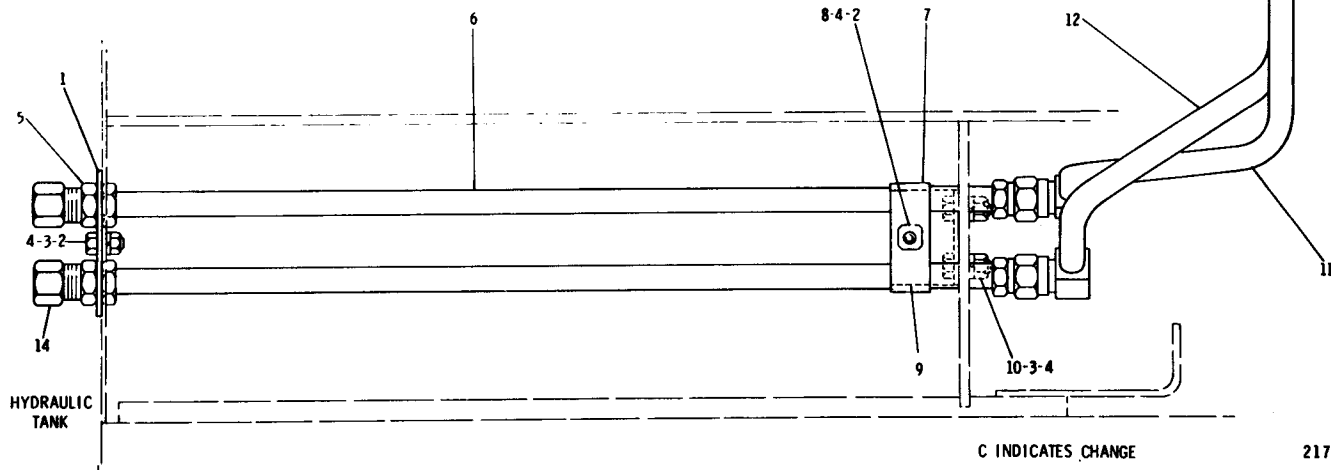

## 6S4111 REAR LINES GROUP

Part of 6S3684 Hydraulic Arrangement listed on Page 71  
AN ATTACHMENT

217319

REF. NO.	PART NUMBER	DESCRIPTION	QTY
1	S1594	BOLT-----	3
2	3B4506	LOCKWASHER-----	7
	4B4278	WASHER-----	7
3	6S7538	BRACKET-----	1
4	S1591	BOLT-----	4
	1D4717	NUT-----	4
C 5	9J1212	FILTER GROUP----- (Separate Illustration)	1

C INDICATES CHANGE

118710

**6S3543 OIL FILTER GROUP**  
Part of 6S3413, 6S3618, 6S3684 and 6S3703 Hydraulic Arrangements listed on Page 71

REF. NO.	PART NUMBER	DESCRIPTION	QTY
1	9J1304	BASE ASSEM. -----	1
C 2	3G2276	GASKET-----	1
3	9J1305	BODY ASSEM. -----	1
4	9J1308	PLUG-----	1
	1F1569	WASHER-----	1
	9M9740	ELEMENT ASSEM. ----- -OR-	1
C 5	3G3467	ELEMENT ASSEM. ----- (Fire Resistant Fluid)	1
6	4J5267	SEAL-----	1
7	9J1306	BOLT ASSEM. -----	1
C 8	4M8184	SPRING-----	1
9	9J1307	RETAINER-----	1
10	2J6356	RING-----	1

C INDICATES CHANGE  
▲ NOT PART OF 9J1212 OIL FILTER GROUP

216630

**9J1212 OIL FILTER GROUP**  
Part of 6S3543 Oil Filter Group



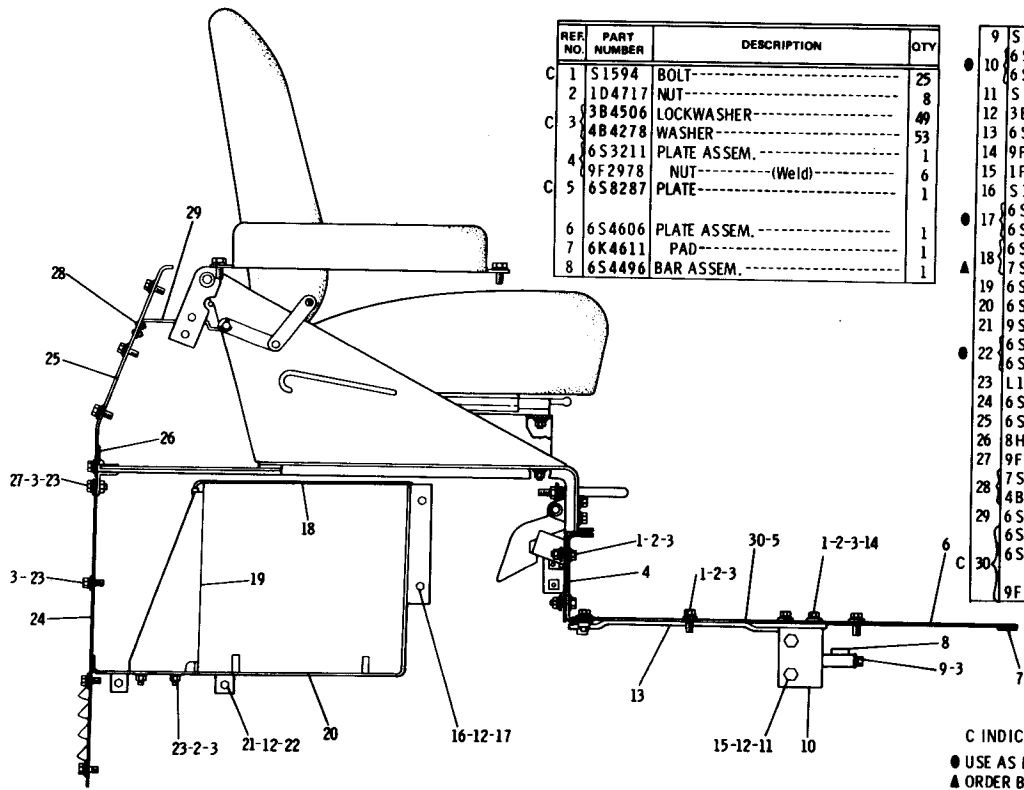

REF. NO.	PART NUMBER	DESCRIPTION	QTY
C 1	51594	BOLT-----	25
2	1D4717	NUT-----	8
C 3	3B4506	LOCKWASHER-----	49
4	4B4278	WASHER-----	53
4	6S3211	PLATE ASSEM.-----	1
4	9F2978	NUT----- (Weld)	6
C 5	6S8287	PLATE-----	1
6	6S4606	PLATE ASSEM.-----	1
7	6K4611	PAD-----	1
8	6S4496	BAR ASSEM.-----	1

9	51608	BOLT-----	2
10	6S6821	SHIM----- (.060 in. Thick)	4
10	6S6820	SHIM----- (.036 in. Thick)	4
11	51585	BOLT-----	4
12	3B4508	LOCKWASHER-----	12
13	6S4629	SUPPORT ASSEM.-----	1
14	9F2978	NUT----- (Weld)	11
15	1F748	NUT----- (Weld)	4
16	51621	BOLT-----	4
17	6S6853	SHIM----- (.036 in. Thick)	4
17	6S6854	SHIM----- (.060 in. Thick)	4
18	6S4055	PLATE-----	1
18	7S625	SEAL----- 12 in.	1
19	6S7565	PLATE-----	1
20	6S4108	BOX ASSEM.-----	1
21	9S1366	BOLT-----	4
22	6S8086	SHIM----- (.036 in. Thick)	8
22	6S8087	SHIM----- (.060 in. Thick)	8
23	L1351	BOLT-----	22
24	6S3299	COVER-----	1
25	6S3353	SUPPORT ASSEM.-----	1
26	8H2282	HINGE-----	2
27	9F2978	NUT----- (Weld)	2
28	7S1197	SCREW-----	2
28	4B2043	NUT-----	2
29	6S4024	CLIP-----	1
30	6S8289	PLATE ASSEM.----- (R. H.)	1
30	6S8288	PLATE ASSEM.----- (L. H.)	1
30	9F2978	NUT----- (Each Includes)	1

C INDICATES CHANGE

● USE AS REQUIRED - R. H. SIDE ONLY

▲ ORDER BY THE FOOT

147611

6S5965 SUPPORT AND SEAT GROUP—Part 1  
 Serial No. 79U1 to 79U3189 inclusive  
 Note: 6D4709 Seat Belt Assembly is available

6S5965 SUPPORT AND SEAT GROUP—Part 2  
Serial No. 79U1 to 79U3189 inclusive

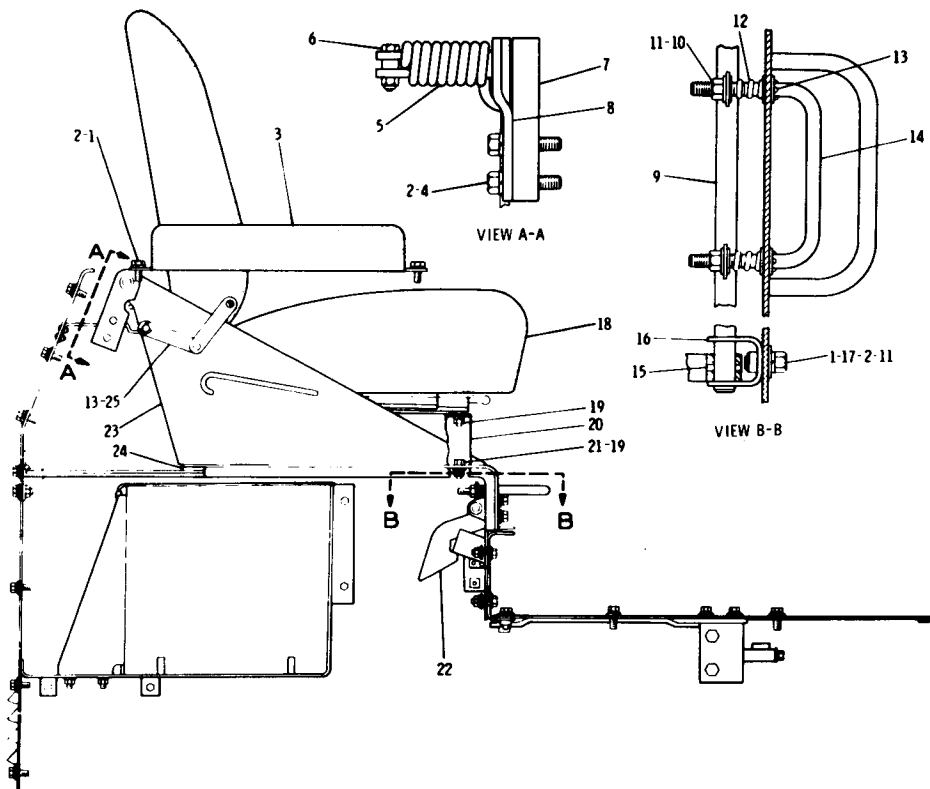

REF. NO.	PART NUMBER	DESCRIPTION	QTY
1	L1351	BOLT-----	8
2	3B4506	LOCKWASHER-----	12
3	6S4624	ARMREST-----	2
4	S1571	BOLT-----	4
5	6S3155	SPRING----- (R. H.)	1
	6S3156	SPRING----- (L. H.)	1
	7B2742	BOLT-----	2
6	7H8909	NUT-----	2
	9F3691	SPACER-----	2
7	6S4998	PLATE-----	2
C 8	6S7515	PLATE ASSEM.----- (R. H.)	1
	6S4860	PLATE ASSEM.----- (L. H.)	1
9	6S4979	ROD ASSEM.-----	1
C 10	6D47	NUT-----	2
11	4B4278	WASHER-----	12
12	S674	SPRING-----	7
C 13	3B4510	COTTER PIN-----	4
14	6S4975	ROD-----	1
15	6H3956	PIN-----	2
16	6S4984	BRACKET ASSEM.-----	2
17	9F2978	NUT----- (Weld)	2
18	6S4655	SEAT ASSEM.-----	1
	1D4716	NUT-----	8
19	3B4505	LOCKWASHER-----	8
	4B4277	WASHER-----	8
20	6S4747	CHANNEL-----	1
	6S4748	CHANNEL-----	1
21	S1618	BOLT-----	4
22	6S5921	LATCH-----	2
23	6S3198	SUPPORT ASSEM.-----	1
	(Includes)		
C 24	6S3196	STRIP-----	1
25	6S3157	PLATE ASSEM.-----	1

C INDICATES CHANGE

168085

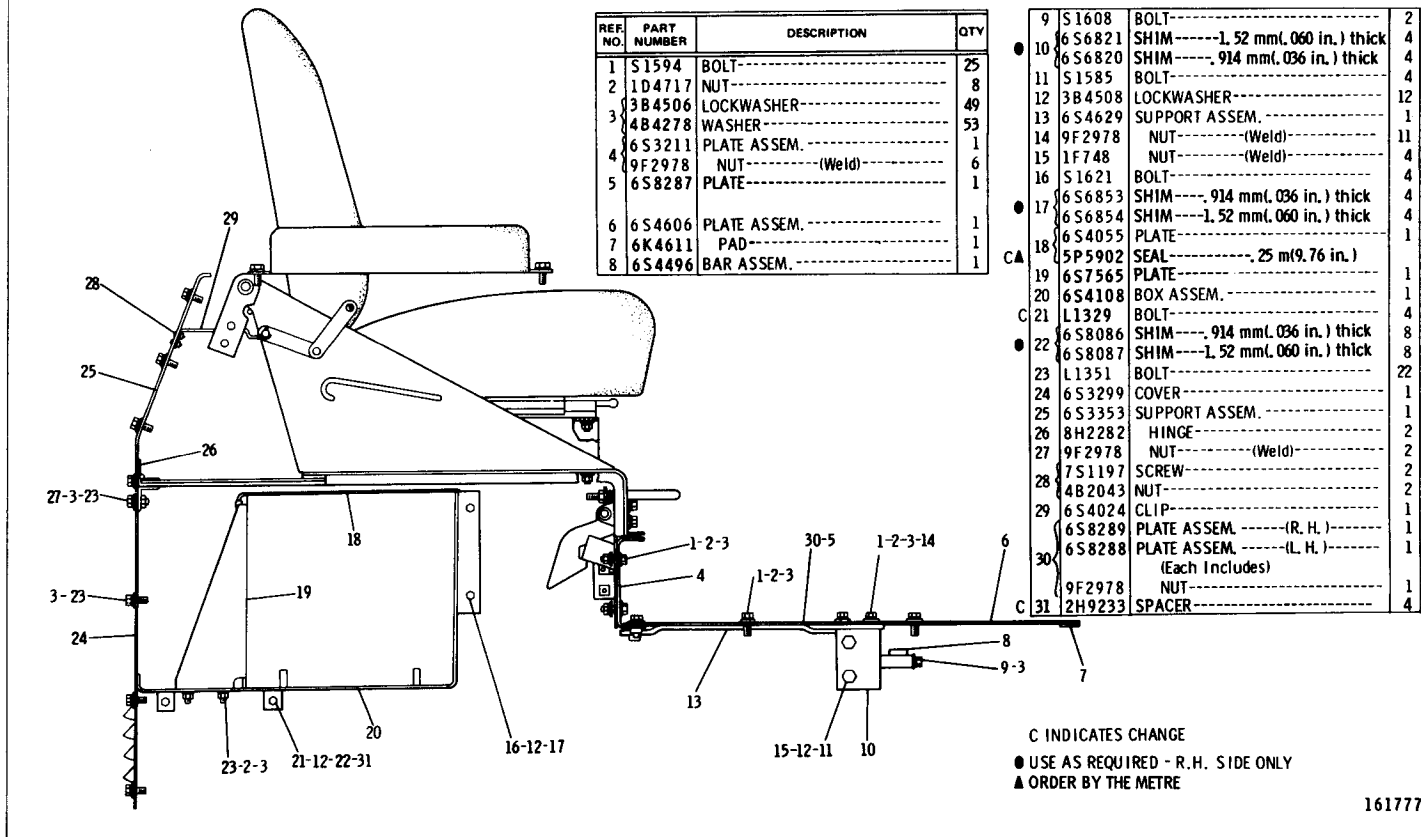

6S5965 SUPPORT AND SEAT GROUP—Part 1  
 Serial no. 79U3190 to 79U4210 inclusive  
 Note: 6D4709 Seat Belt Assembly is available

6S5965 SUPPORT AND SEAT GROUP—Part 2  
 Serial No. 79U3190 to 79U4210 inclusive

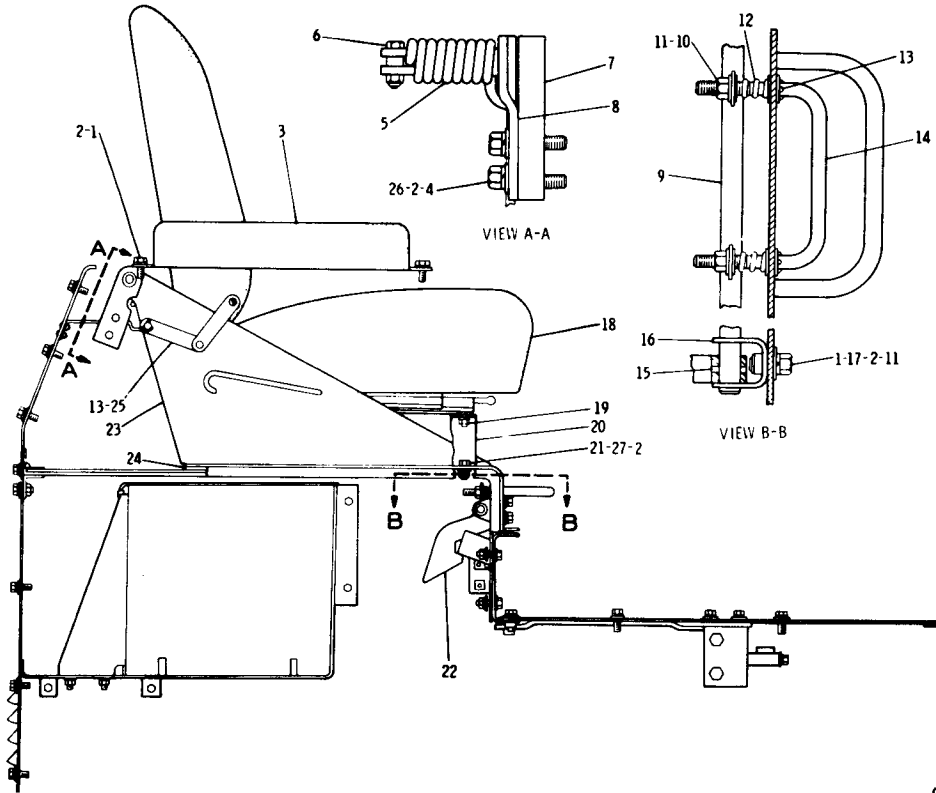

REF. NO.	PART NUMBER	DESCRIPTION	QTY
1	11351	BOLT-----	8
C 2	3B4506	LOCKWASHER-----	16
3	6S4624	ARMREST-----	2
4	S1571	BOLT-----	4
C 5	6S9204	SPRING----- (R. H.)	1
C 5	6S9205	SPRING----- (L. H.)	1
	7B2742	BOLT-----	2
6	7H8909	NUT-----	2
	9F3691	SPACER-----	2
7	6S4998	PLATE-----	2
8	6S7515	PLATE ASSEM.----- (R. H.)	1
9	6S4860	PLATE ASSEM.----- (L. H.)	1
	6S4979	ROD ASSEM.-----	1
10	6D47	NUT-----	2
11	4B4278	WASHER-----	12
12	S674	SPRING-----	2
13	3B4610	COTTER PIN-----	4
14	6S4975	ROD-----	1
15	6H3956	PIN-----	2
16	6S4984	BRACKET ASSEM.-----	2
17	9F2978	NUT----- (Weld)	2
18	6S4655	SEAT ASSEM.-----	1
C 19	1D4716	NUT-----	4
C 19	3B4505	LOCKWASHER-----	4
C 20	4B4277	WASHER-----	4
	6S4747	CHANNEL-----	1
20	6S4748	CHANNEL-----	1
C 21	S1594	BOLT-----	4
22	6S5921	LATCH-----	2
23	6S3198	SUPPORT ASSEM.----- (Includes)	1
C 24	6S3196	STRIP-----	1
25	6S3157	PLATE ASSEM.-----	1
C 26	3K925	WASHER-----	4
C 27	1D4717	NUT-----	4

C INDICATES CHANGE

168086

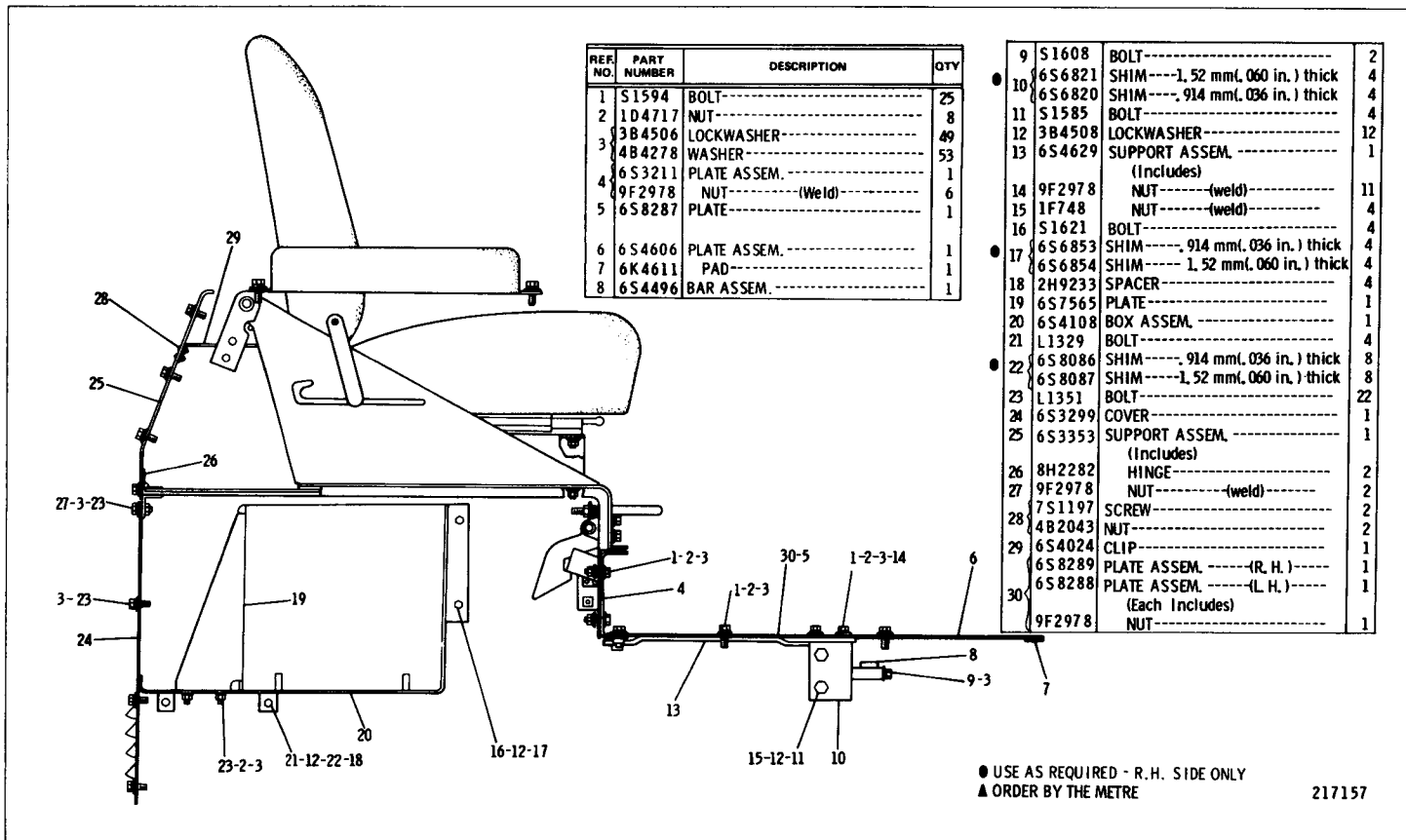

6S5965 SUPPORT AND SEAT GROUP—Part 1  
 Serial No. 79U4211—Up  
 Note: 6D4709 Seat Belt Assembly is available

217157

6S5965 SUPPORT AND SEAT GROUP—Part 2  
Serial No. 79U4211—Up

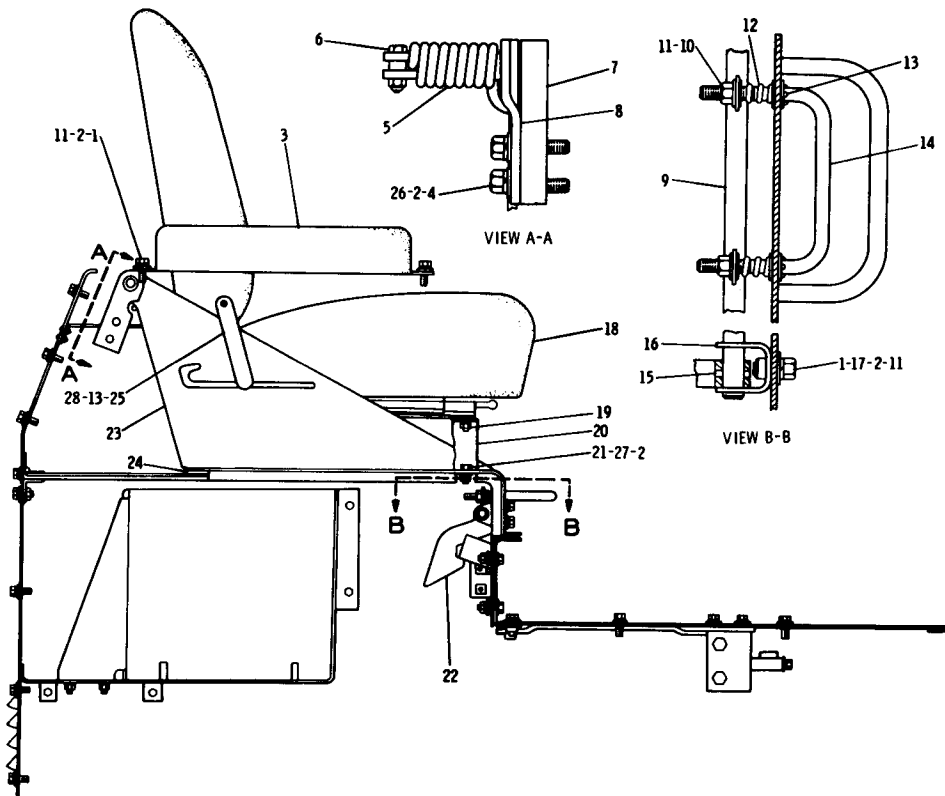

REF. NO.	PART NUMBER	DESCRIPTION	QTY
1	L1351	BOLT-----	8
2	3B4506	LOCKWASHER-----	16
3	6S4624	ARMREST-----	2
4	S1571	BOLT-----	4
5	6S9204	SPRING----- (R. H.)	1
	6S9205	SPRING----- (L. H.)	1
	7B2742	BOLT-----	2
6	7H8909	NUT-----	2
	9F3691	SPACER-----	2
7	6S4998	PLATE-----	2
8	6S7515	PLATE ASSEM.----- (R. H.)	1
	6S4860	PLATE ASSEM.----- (L. H.)	1
9	6S4979	ROD ASSEM.-----	1
10	6D47	NUT-----	2
11	4B4278	WASHER-----	16
12	S674	SPRING-----	2
13	3B4610	COTTER PIN-----	3
14	6S4975	ROD-----	1
15	6H3956	PIN-----	2
16	6S4984	BRACKET ASSEM.-----	2
17	9F2978	NUT----- (Weld)	2
18	6S4655	SEAT ASSEM.-----	1
	1D4716	NUT-----	4
19	3B4505	LOCKWASHER-----	4
	4B4277	WASHER-----	4
20	6S4747	CHANNEL-----	1
	6S4748	CHANNEL-----	1
21	S1594	BOLT-----	4
22	6S5921	LATCH-----	2
23	5G681	SUPPORT ASSEM.----- (Includes)	1
24	6S3196	STRIP-----	1
25	5G674	PLATE ASSEM.-----	1
26	3K925	WASHER-----	4
27	1D4717	NUT-----	4
28	4B5271	WASHER-----	1
	3B4615	COTTER PIN-----	1

C INDICATES CHANGE

217158

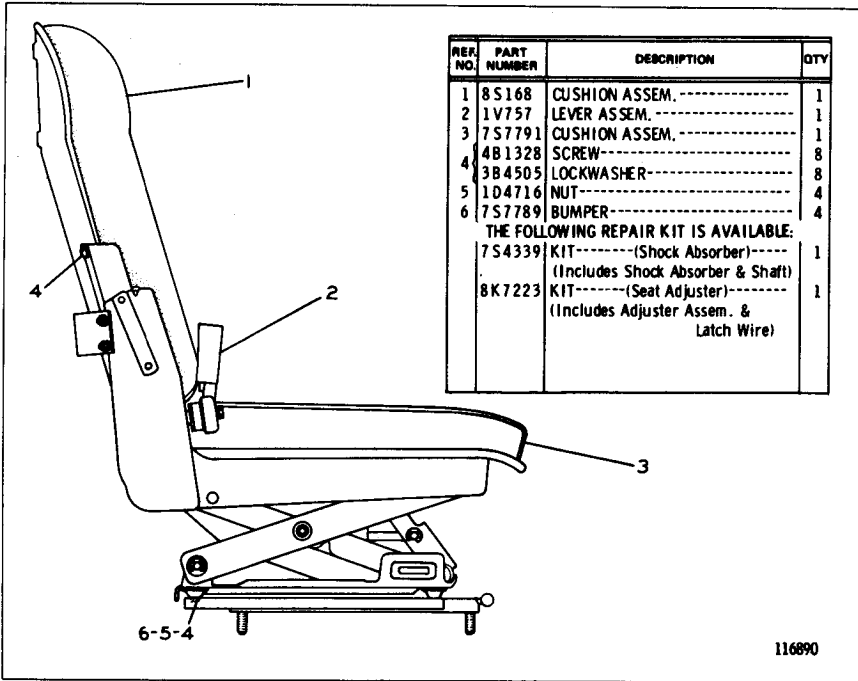

REF. NO.	PART NUMBER	DESCRIPTION	QTY.
1	8S168	CUSHION ASSEM.-----	1
2	1V757	LEVER ASSEM.-----	1
3	7S7791	CUSHION ASSEM.-----	1
4	4B1328	SCREW-----	8
	3B4505	LOCKWASHER-----	8
5	1D4716	NUT-----	4
6	7S7789	BUMPER-----	4
THE FOLLOWING REPAIR KIT IS AVAILABLE:			
	7S4339	KIT----- (Shock Absorber) (Includes Shock Absorber & Shaft)	1
	8K7223	KIT----- (Seat Adjuster) (Includes Adjuster Assem. & Latch Wire)	1

6S3626 SUSPENSION SEAT GROUP—Type 1  
AN ATTACHMENT

116890

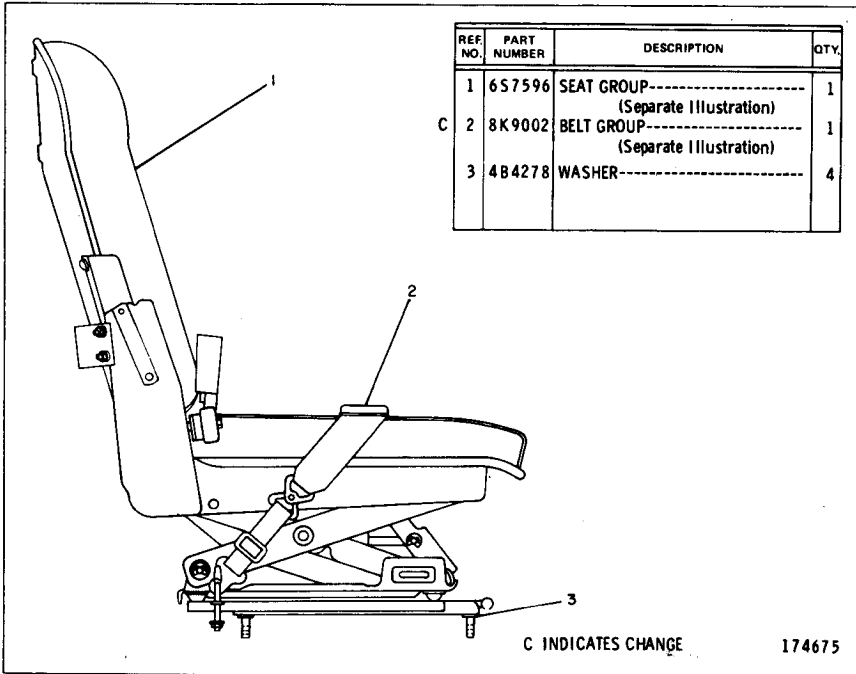

REF. NO.	PART NUMBER	DESCRIPTION	QTY.
1	6S7596	SEAT GROUP----- (Separate Illustration)	1
C 2	8K9002	BELT GROUP----- (Separate Illustration)	1
3	4B4278	WASHER-----	4

C INDICATES CHANGE

174675

6S3626 SUSPENSION SEAT GROUP—Type 2  
6S7596 Seat and 8K9002 Belt parts are shown on Pages 86A and 86A-2  
AN ATTACHMENT

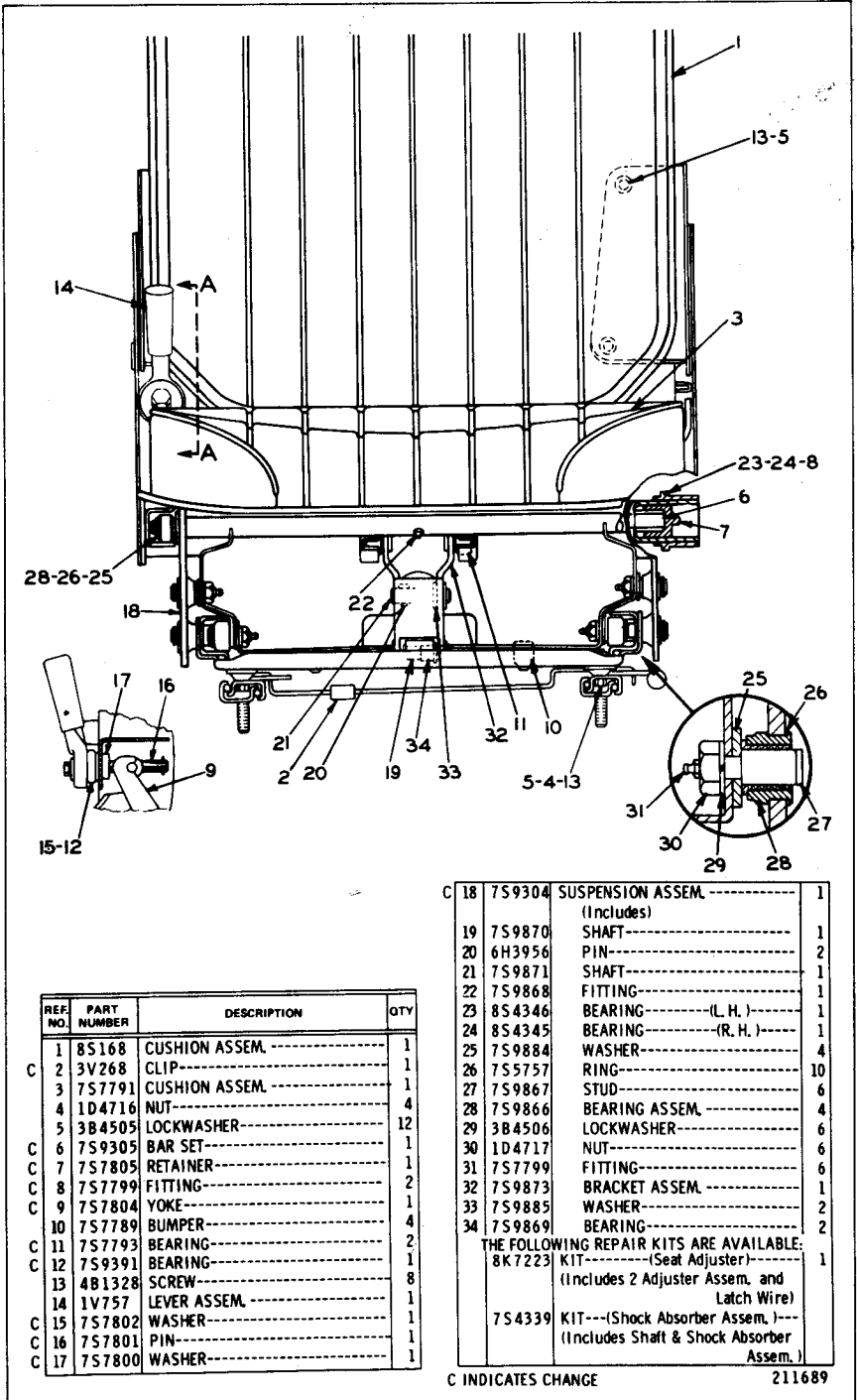

REF. NO.	PART NUMBER	DESCRIPTION	QTY
C 1	8S168	CUSHION ASSEM.-----	1
2	3V268	CLIP-----	1
3	7S7791	CUSHION ASSEM.-----	1
4	1D4716	NUT-----	4
5	3B4505	LOCKWASHER-----	12
C 6	7S9305	BAR SET-----	1
C 7	7S7805	RETAINER-----	1
C 8	7S7799	FITTING-----	2
C 9	7S7804	YOKE-----	1
10	7S7789	BUMPER-----	4
C 11	7S7793	BEARING-----	2
C 12	7S9391	BEARING-----	1
13	4B1328	SCREW-----	8
14	1V757	LEVER ASSEM.-----	1
C 15	7S7802	WASHER-----	1
C 16	7S7801	PIN-----	1
C 17	7S7800	WASHER-----	1

C 18	7S9304	SUSPENSION ASSEM.-----	1
(Includes)			
19	7S9870	SHAFT-----	1
20	6H3956	PIN-----	2
21	7S9871	SHAFT-----	1
22	7S9868	FITTING-----	1
23	8S4346	BEARING----- (L. H.)-----	1
24	8S4345	BEARING----- (R. H.)-----	1
25	7S9884	WASHER-----	4
26	7S5757	RING-----	10
27	7S9867	STUD-----	6
28	7S9866	BEARING ASSEM.-----	4
29	3B4506	LOCKWASHER-----	6
30	1D4717	NUT-----	6
31	7S7799	FITTING-----	6
32	7S9873	BRACKET ASSEM.-----	1
33	7S9885	WASHER-----	2
34	7S9869	BEARING-----	2
THE FOLLOWING REPAIR KITS ARE AVAILABLE:			
8K7223	KIT----- (Seat Adjuster)-----	(Includes 2 Adjuster Assem. and Latch Wire)	1
7S4339	KIT----- (Shock Absorber Assem.)-----	(Includes Shaft & Shock Absorber Assem.)	1

C INDICATES CHANGE

211689

\*6S7596 SEAT GROUP

Part of 6S3626 Suspension Seat Group shown on Page 86



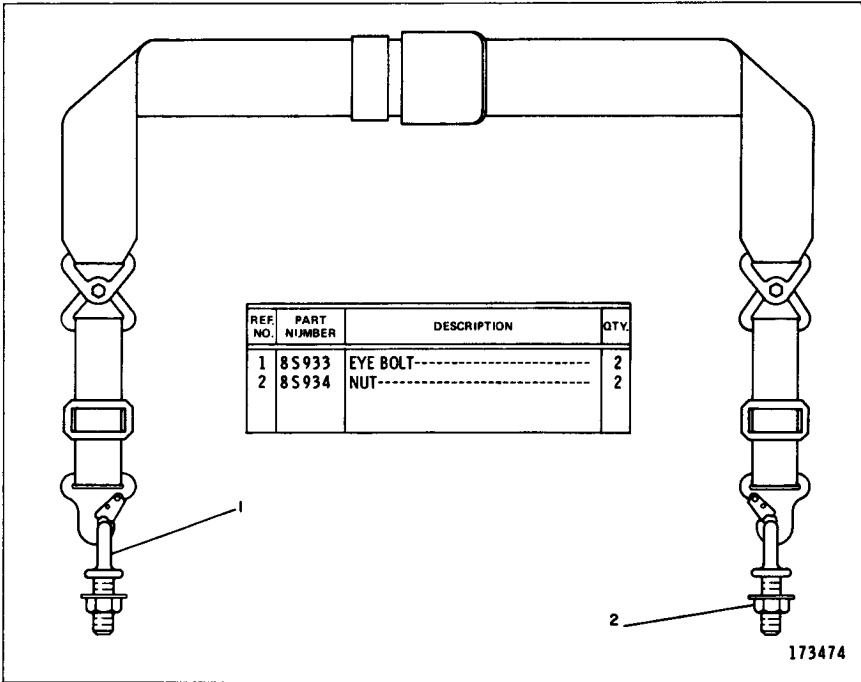

8K9002 SEAT BELT GROUP  
 Part of 6S3626 Suspension Seat Group shown on Page 86  
 AN ATTACHMENT

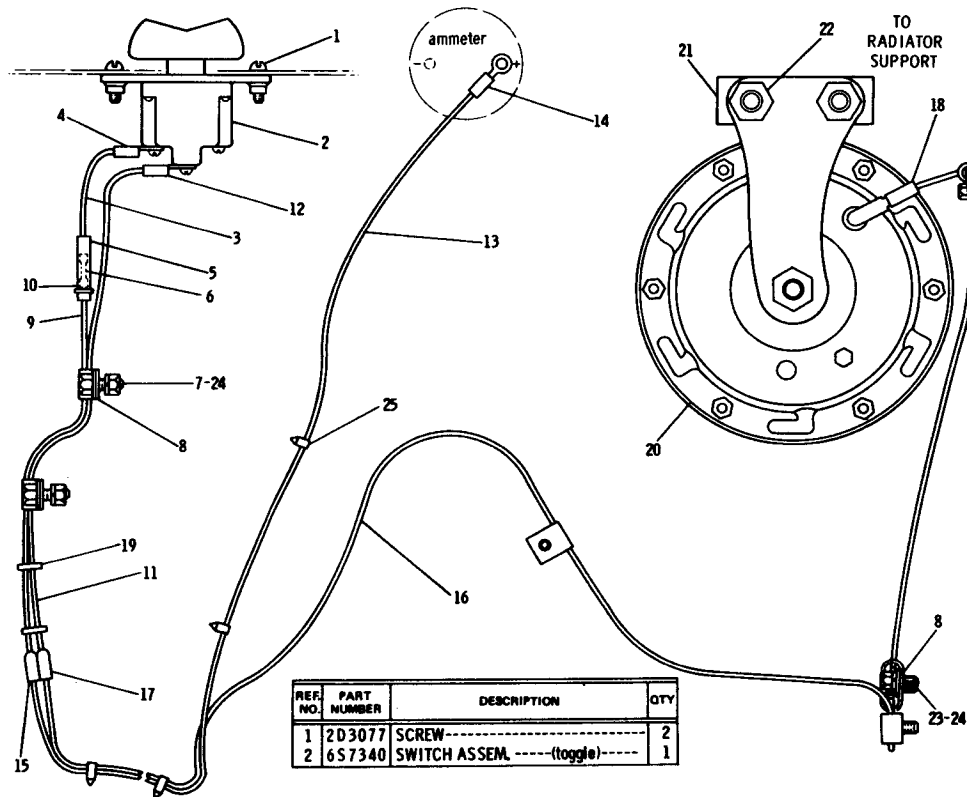

▲ 3	6S7371	WIRE ASSEM.-----	1
	5P632	WIRE-----, 749 dm(2.95 in.)	1
4	2L8074	TERMINAL-----	1
	2S5012	CAP-----	1
5	2S5014	CONTACT-----	1
6	3K8782	FUSE----- (10 amp)	1
	S509	BOLT-----	2
7	1D4717	NUT-----	2
8	8M2772	CLIP-----	7
	6S7370	WIRE ASSEM.-----	1
9	5P632	WIRE-----, 7.75 dm(30.5 in.)	1
	2S5011	BODY-----	1
10	2S5013	SPRING-----	1
	2S5014	CONTACT-----	1
	6S7367	WIRE ASSEM.-----	1
11	5P632	WIRE-----, 8.76 dm(34.5 in.)	1
12	2L8074	TERMINAL-----	1
	6S7369	WIRE ASSEM.-----	1
13	5P632	WIRE-----, 17.25 dm(67.9 in.)	1
C 14	2L8076	TERMINAL-----	1
15	6K613	TERMINAL-----	1
C 16	6S7368	WIRE ASSEM.-----	1
▲ 17	5P632	WIRE-----, 34 dm(134 in.)	1
	6K613	TERMINAL-----	1
18	3P3410	TERMINAL-----	1
	3P3413	SHELL-----	1
C 19	6K806	STRAP-----	2
20	6S7339	HORN ASSEM.-----	1
21	6S7334	SPACER-----	1
	2A4781	BOLT-----	3
C 22	1B4330	NUT-----	3
	3B4504	LOCKWASHER-----	3
C 23	T102	BOLT-----	5
C 24	3B4506	LOCKWASHER-----	7
C 25	3S2093	STRAP-----	5

▲ ORDER BY THE DECIMETRE  
C INDICATES CHANGE

150733

6S7338 ELECTRIC HORN GROUP  
AN ATTACHMENT

6S7338 ELECTRIC HORN GROUP—Type 2  
AN ATTACHMENT

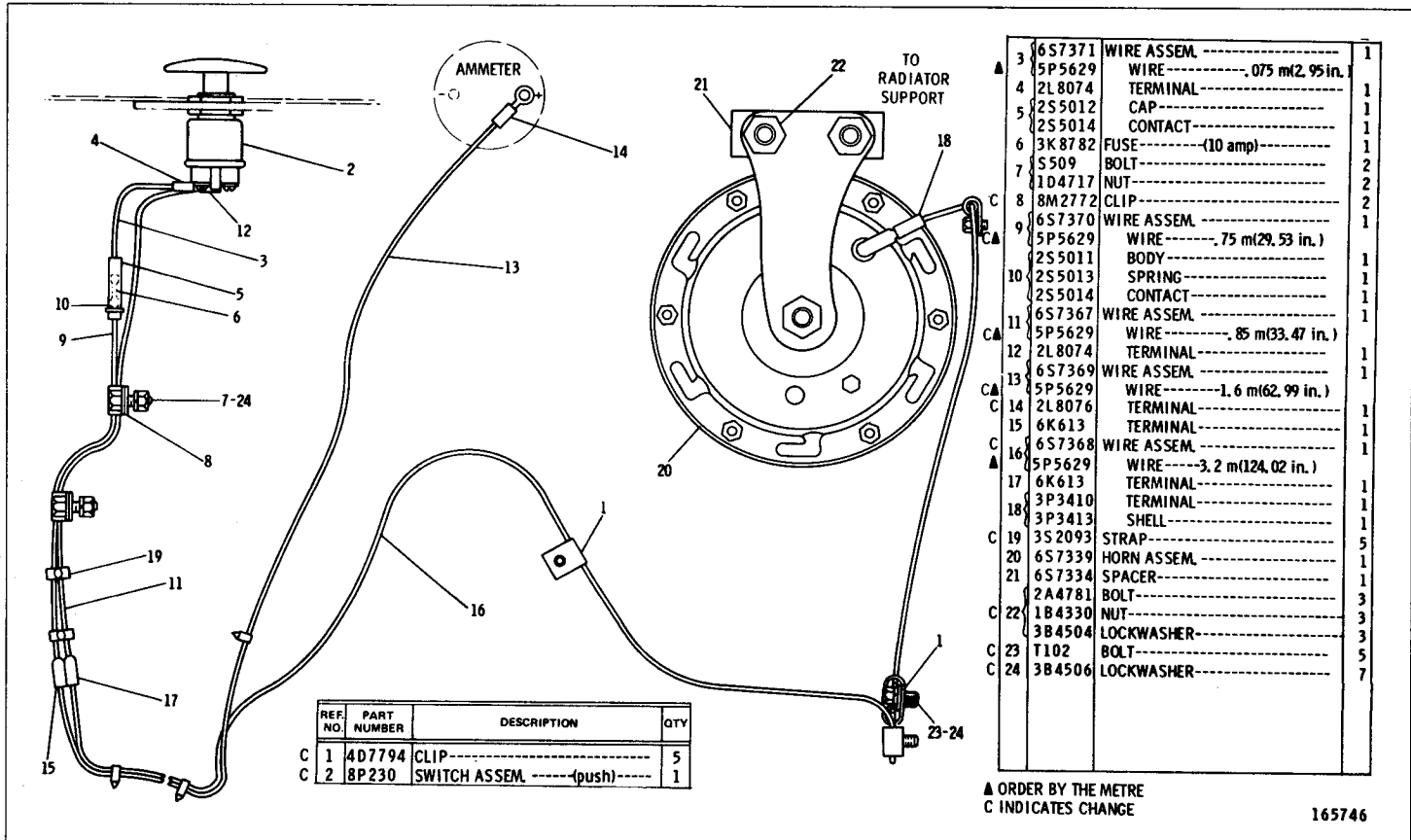

REF. NO.	PART NUMBER	DESCRIPTION	QTY
C 1	4D7794	CLIP-----	5
C 2	8P230	SWITCH ASSEM. -----(push)-----	1

▲ 3	6S7371	WIRE ASSEM. -----	1
	5P5629	WIRE -----, 075 m(2.95 in.)	1
4	2L8074	TERMINAL-----	1
5	2S5012	CAP-----	1
	2S5014	CONTACT-----	1
6	3K8782	FUSE----- (10 amp)-----	1
7	S509	BOLT-----	2
	1D4717	NUT-----	2
8	8M2772	CLIP-----	2
9	6S7370	WIRE ASSEM. -----	1
	5P5629	WIRE -----, 75 m(29.53 in.)	1
	2S5011	BODY-----	1
10	2S5013	SPRING-----	1
	2S5014	CONTACT-----	1
11	6S7367	WIRE ASSEM. -----	1
	5P5629	WIRE -----, 85 m(33.47 in.)	1
12	2L8074	TERMINAL-----	1
13	6S7369	WIRE ASSEM. -----	1
	5P5629	WIRE -----, 1.6 m(62.99 in.)	1
14	2L8076	TERMINAL-----	1
15	6K613	TERMINAL-----	1
16	6S7368	WIRE ASSEM. -----	1
	5P5629	WIRE -----, 3.2 m(124.02 in.)	1
17	6K613	TERMINAL-----	1
18	3P3410	TERMINAL-----	1
	3P3413	SHELL-----	1
19	3S2093	STRAP-----	5
20	6S7339	HORN ASSEM. -----	1
21	6S7334	SPACER-----	1
	2A4781	BOLT-----	3
	1B4330	NUT-----	3
	3B4504	LOCKWASHER-----	3
23	T102	BOLT-----	5
24	3B4506	LOCKWASHER-----	7

▲ ORDER BY THE METRE  
C INDICATES CHANGE

165746

CAB, GAUGES AND ACCESSORIES

86C

CATERPILLAR D3 TRACTOR

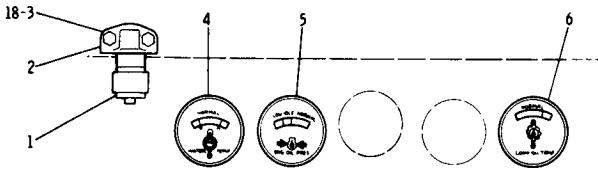

VIEW A-A

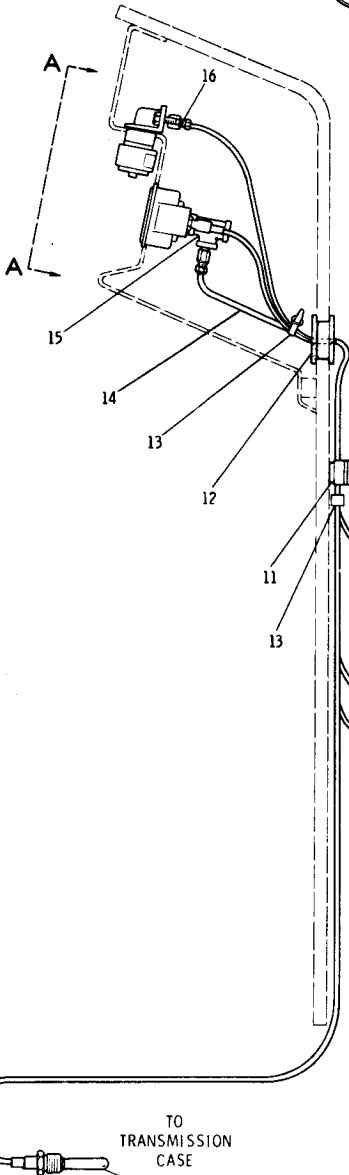

REF. NO.	PART NUMBER	DESCRIPTION	QTY
1	7S687	INDICATOR-----	1
2	1P6886	ADAPTER-----	1
3	S1616	BOLT-----	2
3	3H6782	SPACER-----	2
4	1S1161	INDICATOR---(Water Temperature)---	1
5	5M1065	GAUGE-----(Oil Pressure)-----	1
6	8M9378	INDICATOR---(Oil Temperature)---	1
7	T102	BOLT-----	1
7	3B4506	LOCKWASHER-----	1
8	8H6912	FITTING-----	2

9	6H6699	ADAPTER-----	1
10	1S666	ADAPTER-----	1
C 11	4D7794	CLAMP-----	1
12	6S4039	GROMMET-----	1
C 13	3S2093	STRAP-----	2
C 14	5P580	TUBE-----21 dm(82.67 in.)	1
15	1Y7551	TEE-----	1
16	4D4158	FITTING-----	2
		(Includes)	
	8H6913	NUT-----	1
C 17	8M2772	CLIP-----	2
C 18	4B4276	WASHER-----	4

10 C INDICATES CHANGE ▲ ORDER BY THE DECIMETRE 147610

6S3507 GAUGE GROUP  
Serial No. 79U1 to 79U2855 inclusive

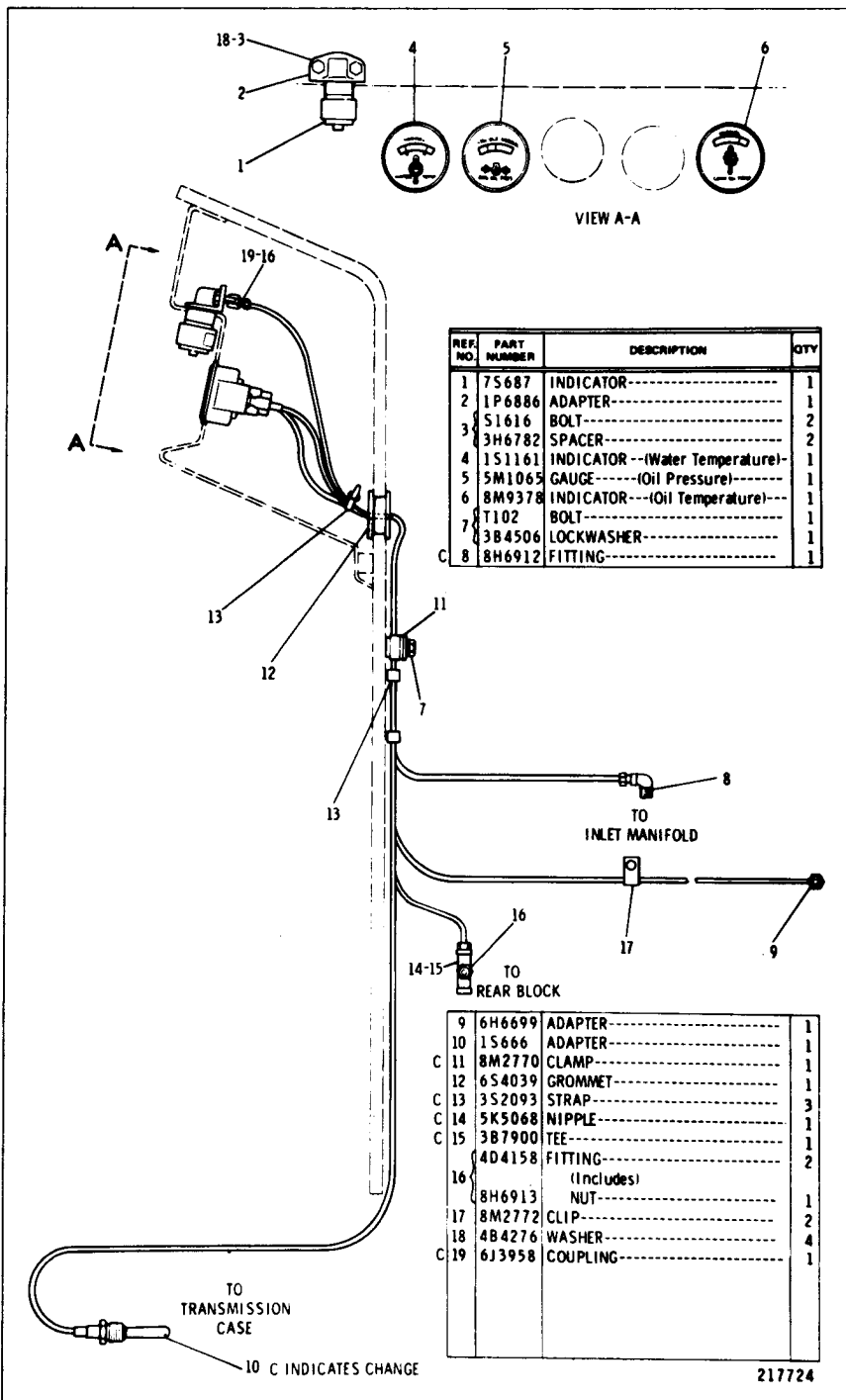

6S3507 GAUGE GROUP  
Serial No. 79U2856 to 79U4121 inclusive

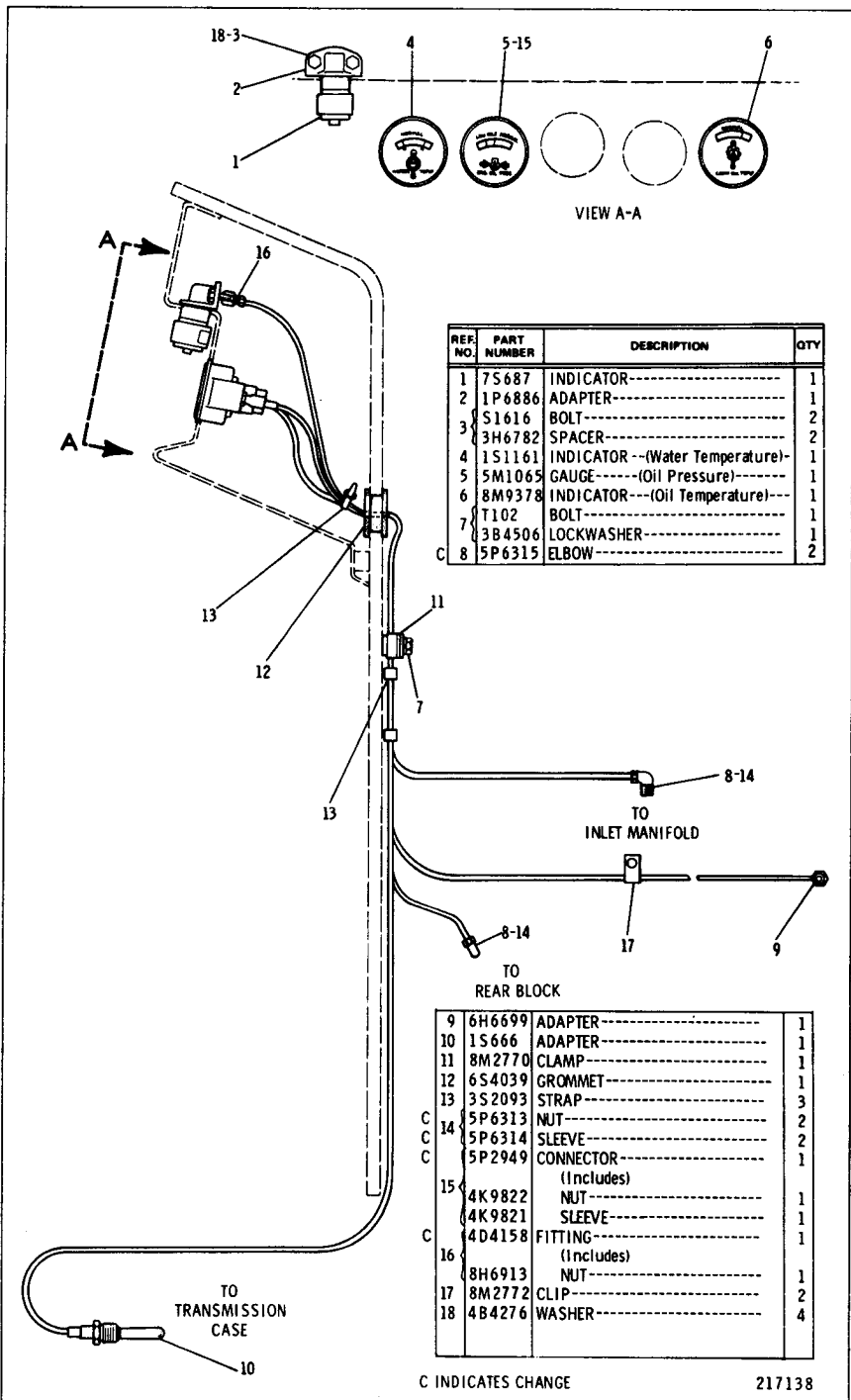

6S3607 GAUGE GROUP  
Serial No. 79U4122—Up

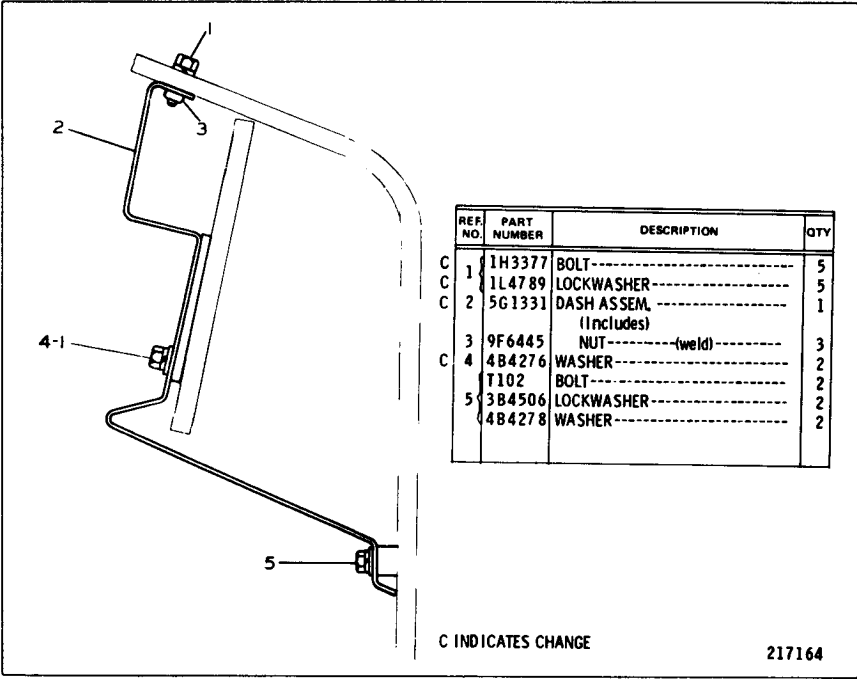

REF. NO.	PART NUMBER	DESCRIPTION	QTY
C 1	1H3377	BOLT-----	5
C 1	1L4789	LOCKWASHER-----	5
C 2	5G1331	DASH ASSEM. (includes)	1
3	9F6445	NUT-----(-weld)-	3
C 4	4B4276	WASHER-----	2
	T102	BOLT-----	2
5	3B4506	LOCKWASHER-----	2
	4B4278	WASHER-----	2

C INDICATES CHANGE

217164

6S3508 DASH GROUP

6S8250 ARRANGEMENT--OPERATOR--TYPE 1  
FOR U.S. MARKET ONLY

CONSISTS OF:

PAGE

1	6S8120	LINER GROUP .....	88B
1	6S8166	CAB LINER GROUP .....	88C
1	6S8167	CAB LINER GROUP .....	88D
1	6S8172	CAB FLOORMAT GROUP .....	88B
1	6S8175	CAB LINER GROUP .....	88C

6S8250 ARRANGEMENT--OPERATOR--TYPE 2  
FOR U.S. MARKET ONLY

CONSISTS OF:

1	6S8120	LINER GROUP .....	88B
1	6S8166	CAB LINER GROUP .....	88C
1	6S8167	CAB LINER GROUP .....	88D
1	6S8172	CAB FLOORMAT GROUP .....	88B
1	6S8175	CAB LINER GROUP .....	88C
1	6S8640	LINER GROUP .....	88E
1	.....	FORM GEG02515	

6S8400 ARRANGEMENT--SPECTATOR  
FOR EUROPEAN USE ONLY

CONSISTS OF:

1	4N5202	MUFFLER GROUP .....	16A
1	6S8080	LINER GROUP .....	88D
1	6S8083	LINER GROUP .....	88E

6S8500 ARRANGEMENT--SPECTATOR  
FOR EUROPEAN USE ONLY

CONSISTS OF:

1	4N5202	MUFFLER GROUP .....	16A
1	6S8083	LINER GROUP .....	88E
1	6S8169	HOOD AND GUARD GROUP .....	54B
	- OR -		
1	6S9699	HOOD AND GUARD GROUP .....	54B-2
1	6S8174	RADIATOR GUARD GROUP .....	11A
	- OR -		
1	6S9697	RADIATOR GUARD GROUP .....	11



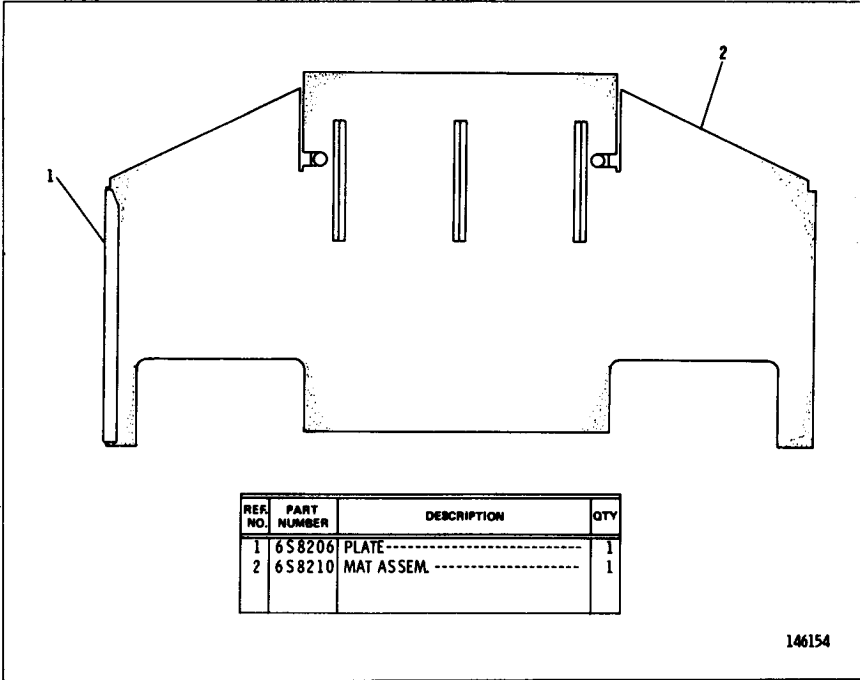

6S8172 CAB FLOORMAT GROUP  
 Part of 6S8250 Noise Suppression Arrangement listed on Page 88A

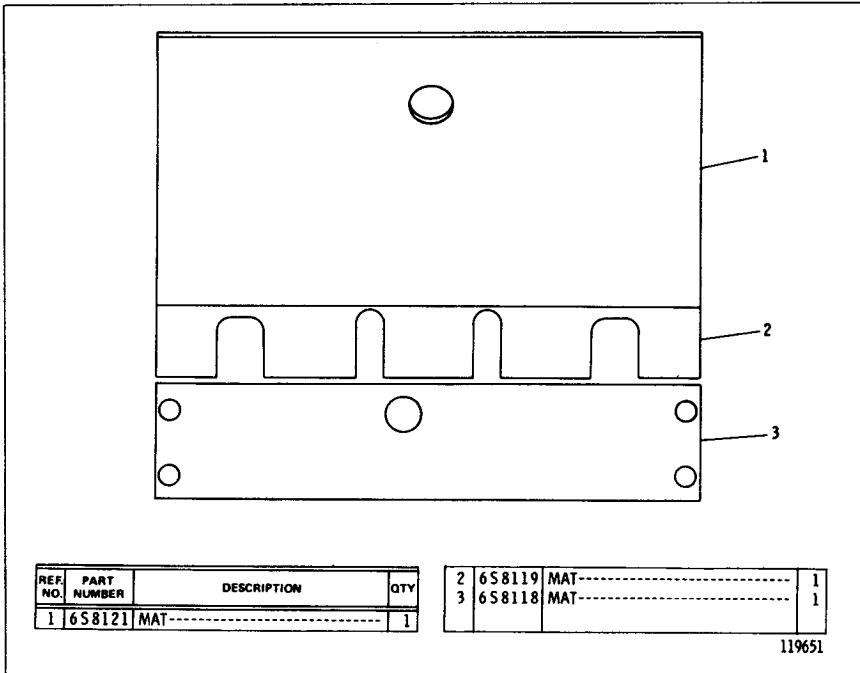

6S8120 LINER GROUP—Under Seat  
 Part of 6S8250 Noise Suppression Arrangement listed on Page 88A

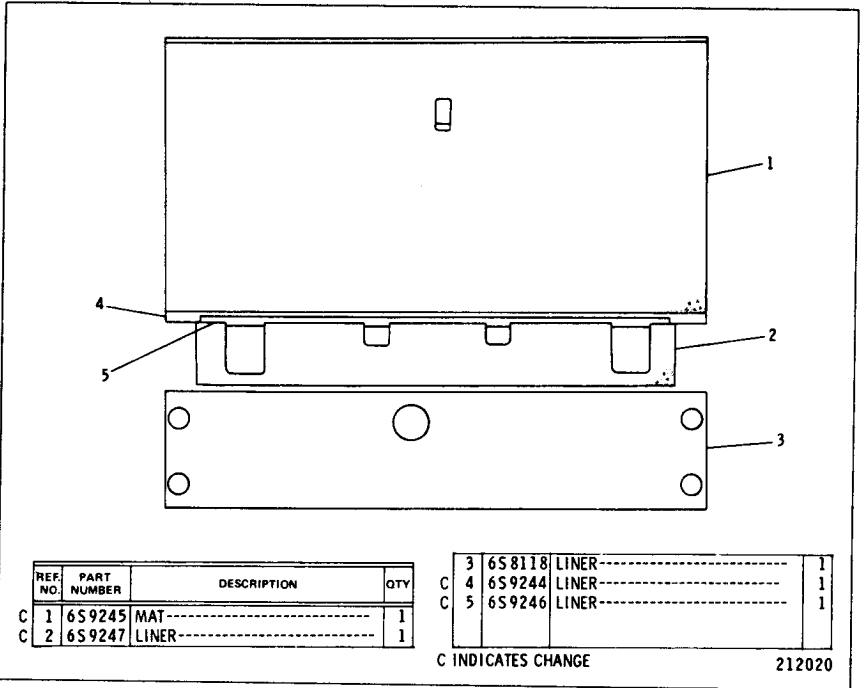

6S8120 LINER GROUP—Under Seat—Type 2  
 Part of 6S8250 Noise Suppression Arrangement listed on Page 88A

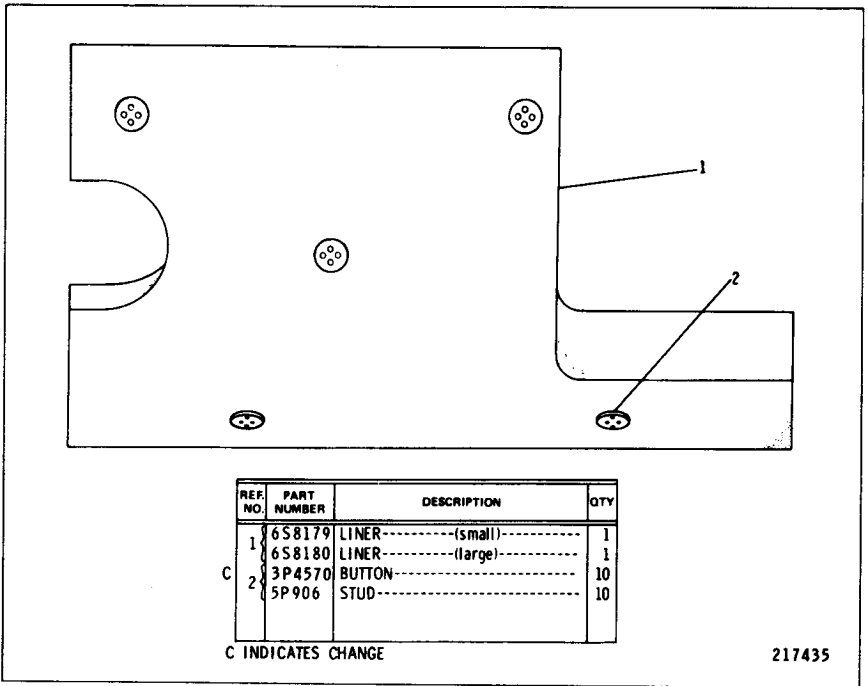

6S8175 CAB LINER GROUP—Tank  
Part of 6S8250 Sound Suppression Arrangement listed on Page 88A

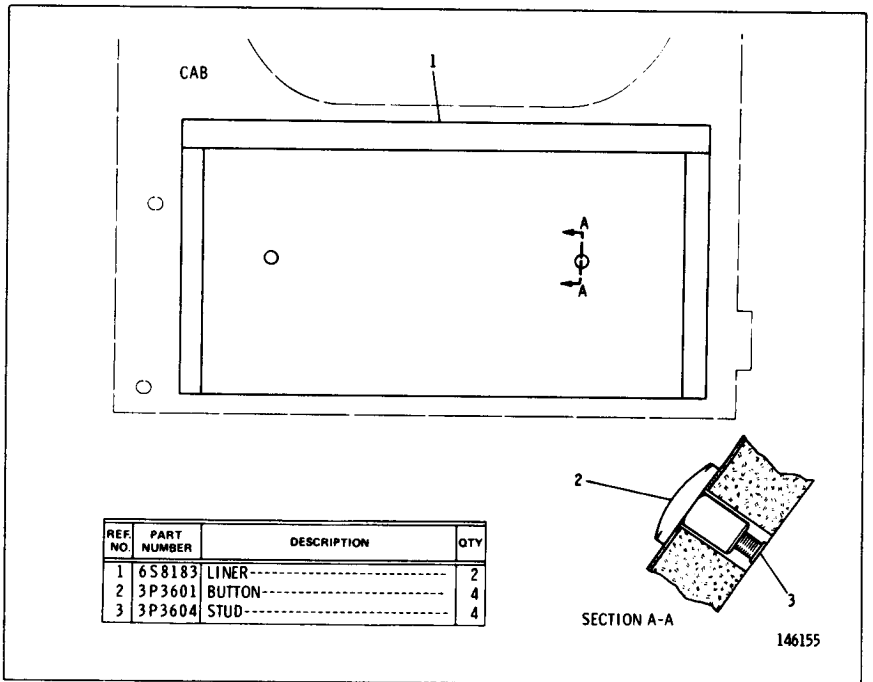

6S8166 CAB LINER GROUP—Front Panel  
Part of 6S8250 Sound Suppression Arrangement listed on Page 88A

CATERPILLAR D3 TRACTOR

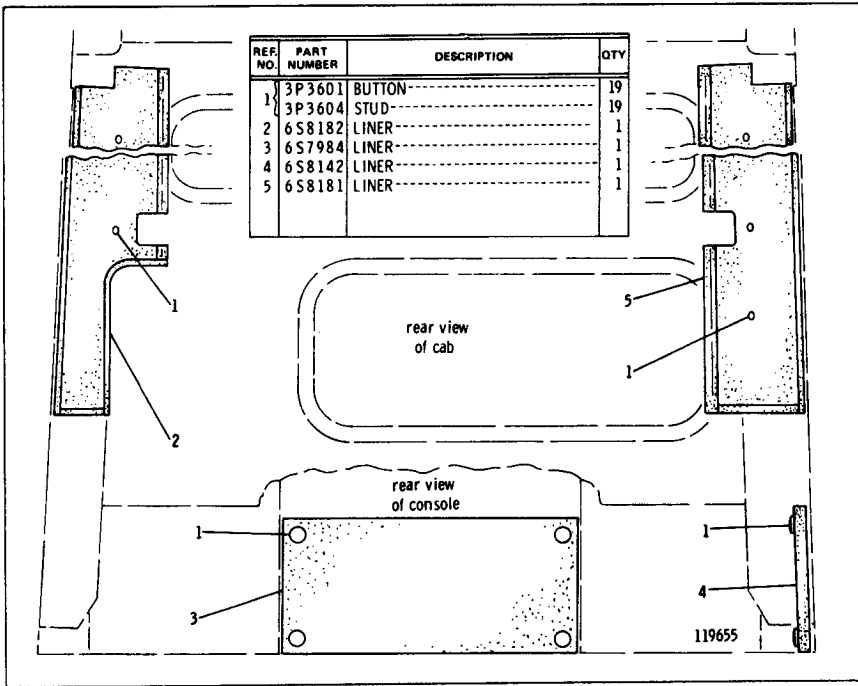

6S8167 CAB LINER GROUP—Sidewall  
Part of 6S8250 Noise Suppression Arrangement listed on Page 88A

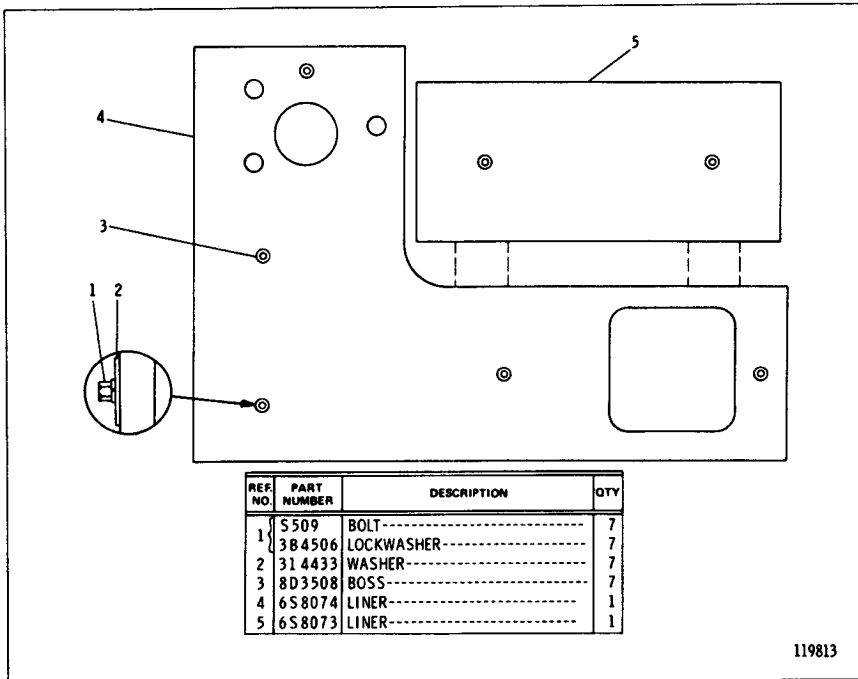

6S8080 LINER GROUP—Hood  
Part of 6S8400 Noise Suppression Arrangement listed on Page 88A

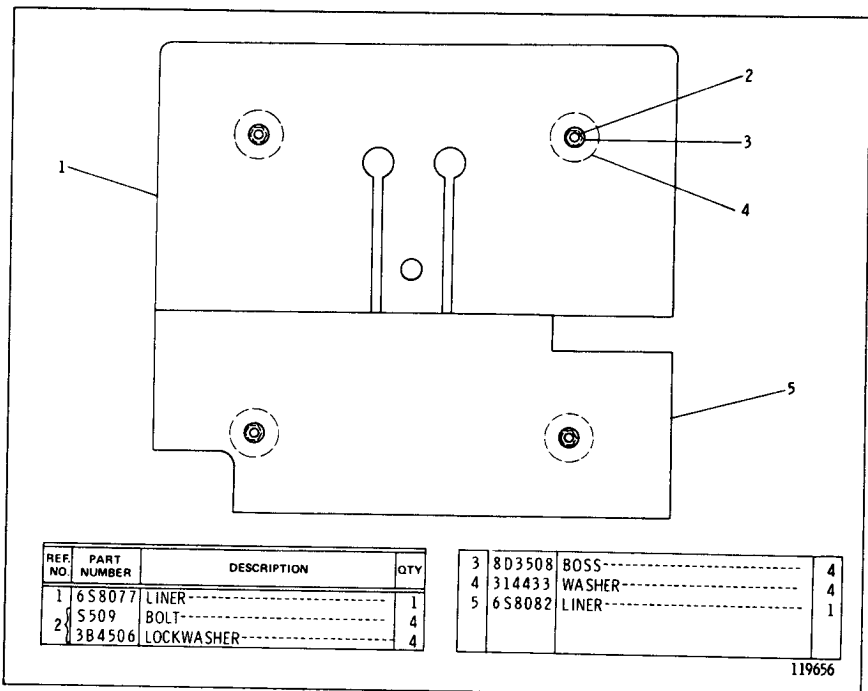

6S8083 LINER GROUP—Firewall  
 Part of 6S8400 and 6S8500 Noise Suppression Arrangements listed on Page 88A

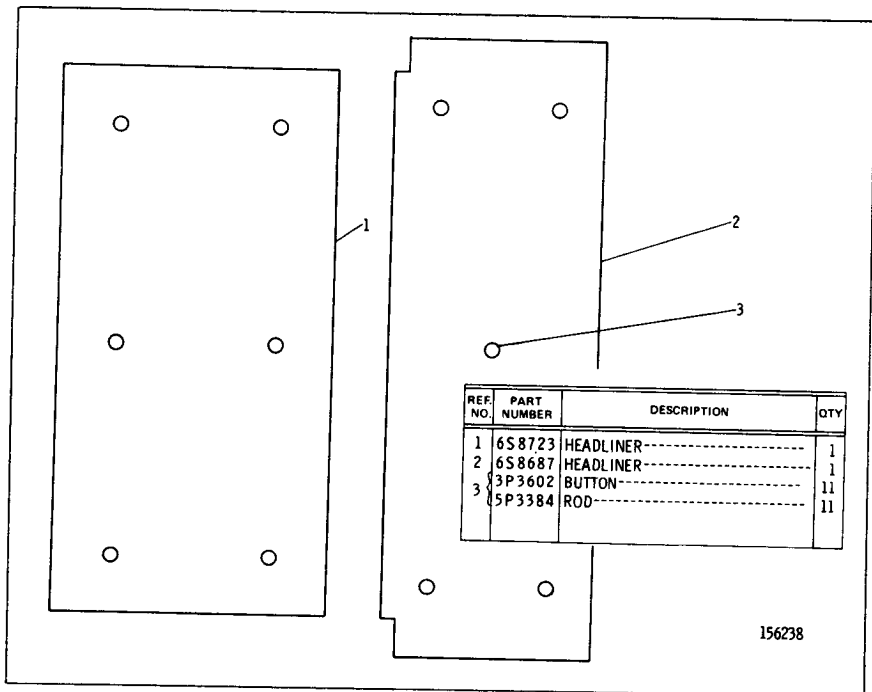

6S8640 LINER GROUP—Canopy  
 Part of 6S8250 Noise Suppression Arrangement listed on Page 88A

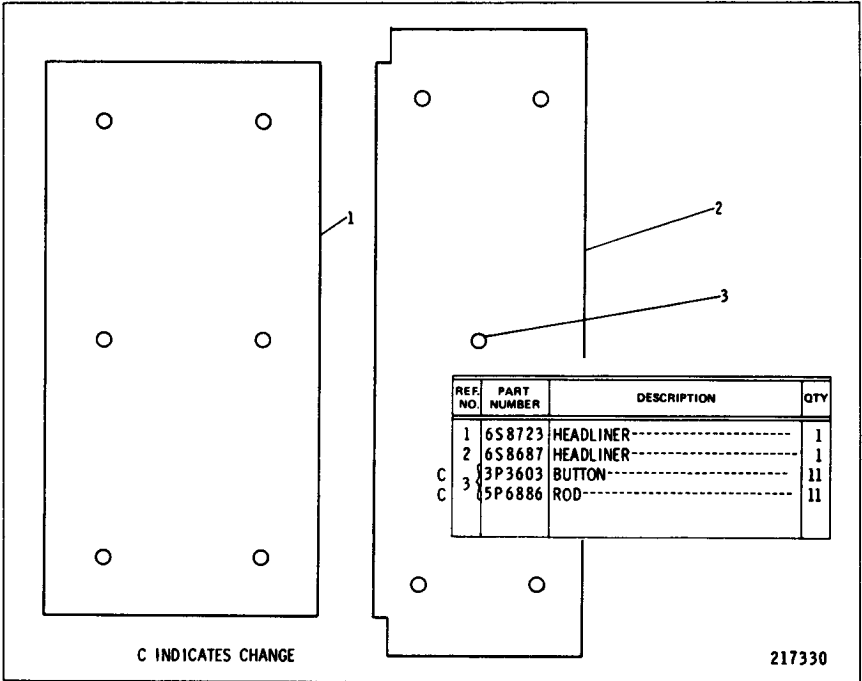

6S8640 LINER GROUP—Canopy—Type 2  
 Part of 6S8250 Sound Suppression Arrangement listed on Page 88

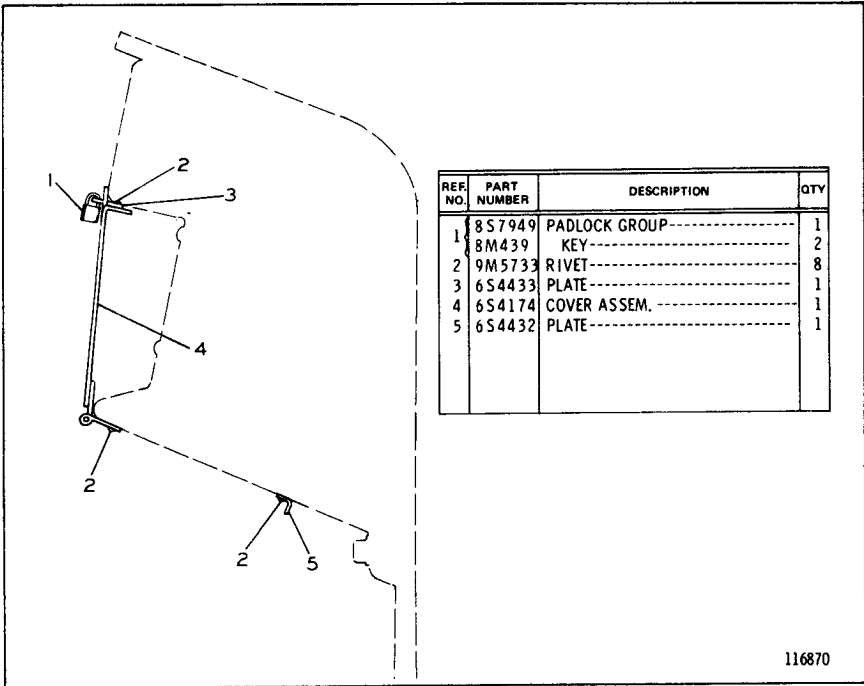

116870

6S4136 VANDALISM GUARD GROUP—Instrument Panel  
Part of 6S8336 and 6S3537 Vandalism Protection Arrangements

CONSISTS OF:

PAGE

1	5D1910	PROTECTION COVER GROUP.....	70
1	1P8678	PROTECTION COVER GROUP.....	20
1	6S4136	VANDALISM GUARD GROUP.....	88F

6S8336 VANDALISM PROTECTION ARRANGEMENT  
CANNOT BE USED WITH CAB  
AN ATTACHMENT

CONSISTS OF:		PAGE
1	5D1910 PROTECTION COVER GROUP.....	70
1	1P8678 PROTECTION COVER GROUP.....	20
1	6S4136 VANDALISM GUARD GROUP.....	88F
2	8M438 PADLOCK--TO SEAT SUPPORT AND HOOD DOOR	

6S3537 VANDALISM PROTECTION ARRANGEMENT  
 FOR USE WITH ENGINE ENCLOSURE. Only separate parts serviced. When  
 complete Arrangement is required order 6S8336. AN ATTACHMENT

CONSISTS OF:		PAGE
1	6S4618 OPERATOR PROTECTIVE ARRANGEMENT.....	90
1	6S6224 PANEL GROUP--REAR.....	96
1	6S6226 PANEL GROUP--R.H. ....	92
1	6S6227 PANEL GROUP--L.H. ....	94
1	6S7714 PANEL GROUP--FRONT.....	91
1	..... INSTRUCTION FORM GMG02348	

6S6200 OPERATOR PROTECTION CAB ARRANGEMENT  
 Only separate parts serviced. When complete Arrangement is  
 required order 6S8338 listed on Page 89A. AN ATTACHMENT



## CATERPILLAR D3 TRACTOR

## CONSISTS OF:

PAGE

1	6S8475	CAB ARRANGEMENT.....	89B
1	6S8575	MOUNTING GROUP.....	96A
1	.....	FORM GMG02348	

**6S8573 OPERATOR PROTECTIVE CAB ARRANGEMENT**  
 Only separate parts serviced. When complete Arrangement is  
 required order 6S8338. AN ATTACHMENT

## CONSISTS OF:

PAGE

1	6S8475	CAB ARRANGEMENT.....	89B
1	6S8340	MOUNTING GROUP.....	96B
1	.....	FORM GMG02348	

**6S8338 OPERATOR PROTECTIVE CAB ARRANGEMENT**  
 Only separate parts serviced  
 AN ATTACHMENT

CONSISTS OF:			PAGE
1	6S5810	ROLL-OVER PROTECTIVE STRUCTURE GROUP.....	97
1	6S6224	PANEL GROUP--REAR.....	96
1	6S6226	PANEL GROUP--R.H. ....	92
1	6S6227	PANEL GROUP--L.H. ....	94
1	6S6845	WINDSHIELD WASHER GROUP.....	101
1	6S7697	WINDSHIELD WIPER GROUP.....	99B
1	6S7714	PANEL GROUP--FRONT.....	91
1	6S8561	CAB WIRING GROUP.....	90C

6S8475 CAB ARRANGEMENT—Type 1  
 Part of 6S8573 and 6S8338 Cab Arrangements

CONSISTS OF:			PAGE
1	6S6224	PANEL GROUP--REAR.....	96
1	6S6226	PANEL GROUP--R.H. ....	92
1	6S6227	PANEL GROUP--L.H. ....	94
1	6S6845	WINDSHIELD WASHER GROUP.....	101
1	6S7697	WINDSHIELD WIPER GROUP.....	99B
1	6S7714	PANEL GROUP--FRONT.....	91
1	6S8561	CAB WIRING GROUP.....	90C

6S8475 CAB ARRANGEMENT—Type 2  
 Part of 6S8573 and 6S8338 Cab Arrangements

CONSISTS OF:		PAGE
1	6S3551 MOUNTING GROUP .....	97
1	6S5810 ROLL-OVER PROTECTIVE STRUCTURE GROUP ...	97
1	..... FORM GEG02398	

**6S4618 OPERATOR PROTECTIVE ARRANGEMENT**

Also part of 6S6200 Operator Protective Cab Arrangement listed on Page 89  
AN ATTACHMENT

CONSISTS OF:		PAGE
1	6S6224 PANEL GROUP--REAR .....	96
1	6S6226 PANEL GROUP--R.H. ....	92
1	6S6227 PANEL GROUP--L.H. ....	94
1	6S7714 PANEL GROUP--FRONT .....	91

6S7882 OPERATOR PROTECTIVE CAB CONVERSION ARRANGEMENT—Replaced by  
6S8476 shown on Page 90A  
FIELD INSTALLATION. Converts Roll-Over Protective Structure to a Cab

		CONSISTS OF:	PAGE
1	6S6224	PANEL GROUP--REAR.....	96
1	6S6226	PANEL GROUP--R.H. ....	92
1	6S6227	PANEL GROUP--L.H. ....	94
1	6S6845	WINDSHIELD WASHER GROUP.....	101
1	6S7697	WINDSHIELD WIPER GROUP.....	99B
1	6S7714	PANEL GROUP--FRONT.....	91
1	6S8561	CAB WIRING GROUP.....	90C
14	3B4506	LOCKWASHER--3/8"	
4	4B4278	WASHER	
10	1D4717	NUT	
2	6S6249	PLATE	
2	6S7869	ANGLE ASSEMBLY	
EACH CONSISTING OF:			
2	9F2978	NUT	
1	6S6248	ANGLE	
14	S1588	BOLT	
1	.....	FORM GMG02348	

6S8476 OPERATOR PROTECTIVE CAB CONVERSION ARRANGEMENT—Type 1  
FIELD INSTALLATION  
Converts Roll-Over Protective Structure to a Cab

CONSISTS OF:		PAGE
1	1P8678	CAP GROUP--TO FUEL TANK..... 20
1	6S6224	PANEL GROUP--REAR TO CANOPY..... 96
1	6S6226	PANEL GROUP--R.H. TO CANOPY..... 92
1	6S6227	PANEL GROUP--L.H. TO CANOPY..... 94
1	6S6845	WASHER GROUP--WINDSHIELD TO CAB..... 101
1	6S7697	WIPER GROUP--WINDSHIELD TO CAB..... 99B
1	6S7714	PANEL GROUP--FRONT TO CANOPY..... 91
1	6S8561	WIRING GROUP--CAB TO CAB..... 90C
2	6S6249	PLATE--TO ANGLE ASSEMBLY TO HYDRAULIC AND FUEL TANKS
4	4B4278	WASHER--PLATE TO ANGLE ASSEMBLY
4	S1588	BOLT--PLATE TO ANGLE ASSEMBLY
4	3B4506	LOCKWASHER--PLATE TO ANGLE ASSEMBLY
10	S1588	BOLT--PLATE AND ANGLE ASSEMBLY TO HYDRAULIC AND FUEL TANKS
10	3B4506	LOCKWASHER--PLATE AND ANGLE ASSEMBLY TO HYDRAULIC AND FUEL TANKS
10	1D4717	NUT--PLATE AND ANGLE ASSEMBLY TO HYDRAULIC AND FUEL TANKS
4	6S6251	MOUNT--PLATE TO R.H. AND L.H. PANEL GROUPS
4	1B3310	WASHER--MOUNT TO PLATES
4	3B4508	LOCKWASHER--MOUNT TO PLATES
4	1H2415	BOLT--MOUNT TO PLATES
2	6S7659	BRACKET--FRONT PANEL GROUP TO FIREWALL ASSEMBLY
2	3B4504	LOCKWASHER--BRACKET TO FIREWALL ASSEMBLY
2	1B4330	NUT--BRACKET TO FIREWALL ASSEMBLY
2	S1615	BOLT--BRACKET TO FIREWALL ASSEMBLY
2	2D9535	GROMMET--TO BRACKETS
4	4B5269	WASHER--BRACKETS TO FIREWALL ASSEMBLY
2	6D6235	NUT--BRACKETS TO FIREWALL ASSEMBLY
2	S1616	BOLT--BRACKETS TO FIREWALL ASSEMBLY
1	6S6265	ROD--HYDRAULIC TANK TO SEAT SUPPORT ASSEMBLY
2	4B5269	WASHER--ROD TO SEAT SUPPORT ASSEMBLY
2	3B4607	COTTER--ROD TO SEAT SUPPORT ASSEMBLY
1	6S8555	BRACKET--TO FIREWALL ASSEMBLY
1	6S8556	BRACKET--TO FIREWALL ASSEMBLY
1	.....	FORM GEG02348
1	6S7869	ANGLE ASSEMBLY
CONSISTS OF:		
2	9F2978	NUT
1	6S6248	ANGLE

6S8476 OPERATOR PROTECTIVE CAB CONVERSION ARRANGEMENT—Type 2  
FIELD INSTALLATION. Converts Roll-Over Protective Structure to a Cab

		CONSISTS OF:	PAGE
1	1P8678	CAB GROUP--TO FUEL TANK.....	20
1	6S6224	PANEL GROUP--REAR--TO CANOPY.....	96
1	6S6226	PANEL GROUP--R.H. TO CANOPY.....	92
1	6S6227	PANEL GROUP--L.H. TO CANOPY.....	94
1	6S6845	WASHER GROUP--WINDSHIELD TO CAB.....	101
1	6S7697	WIPER GROUP--WINDSHIELD TO CAB.....	99B
1	6S7714	PANEL GROUP--FRONT TO CANOPY.....	91
1	6S8561	WIRING GROUP--CAB TO CAB.....	90C
2	6S6249	PLATE--TO ANGLE ASSEMBLY TO HYDRAULIC AND FUEL TANKS	
4	4B4278	WASHER--PLATE TO ANGLE ASSEMBLY	
4	S1588	BOLT--PLATE TO ANGLE ASSEMBLY	
4	3B4508	LOCKWASHER--PLATE TO ANGLE ASSEMBLY	
10	S1588	BOLT--PLATE AND ANGLE ASSEMBLY TO HYDRAULIC AND FUEL TANKS	
10	3B3406	LOCKWASHER--PLATE AND ANGLE ASSEMBLY TO HYDRAULIC AND FUEL TANKS	
10	1D4717	NUT--PLATE AND ANGLE ASSEMBLY TO HYDRAULIC AND FUEL TANKS	
4	6S6251	MOUNT--PLATE TO R.H. AND L.H. PANEL GROUPS	
4	1B3310	WASHER--MOUNT TO PLATES	
4	3B4508	LOCKWASHER--MOUNT TO PLATES	
4	1H2415	BOLT--MOUNT TO PLATES	
1	6S9027	BRACKET	
1	6S9028	BRACKET	
2	3B4504	LOCKWASHER--BRACKET TO FIREWALL ASSEMBLY	
4	S1620	BOLT--BRACKET TO FIREWALL	
4	3B4508	LOCKWASHER--BRACKET TO FIREWALL	
1	6S9039	PLATE ASSEMBLY--HYDRAULIC TANK TO SEAT SUPPORT ASSEMBLY	
1	4B5269	WASHER--ROD TO SEAT SUPPORT ASSEMBLY	
1	3B4607	COTTER--ROD TO SEAT SUPPORT ASSEMBLY	
1	6S8555	BRACKET--TO FIREWALL ASSEMBLY	
1	6S8556	BRACKET--TO FIREWALL ASSEMBLY	
1	.....	FORM GEG02349	
1	6S7869	ANGLE ASSEMBLY	
		CONSISTING OF:	
2	9F2978	NUT	
1	6S6248	ANGLE	

6S8476 OPERATOR PROTECTIVE CAB CONVERSION ARRANGEMENT—Type 3  
FIELD INSTALLATION. Converts Roll-Over Protective Structure to a Cab

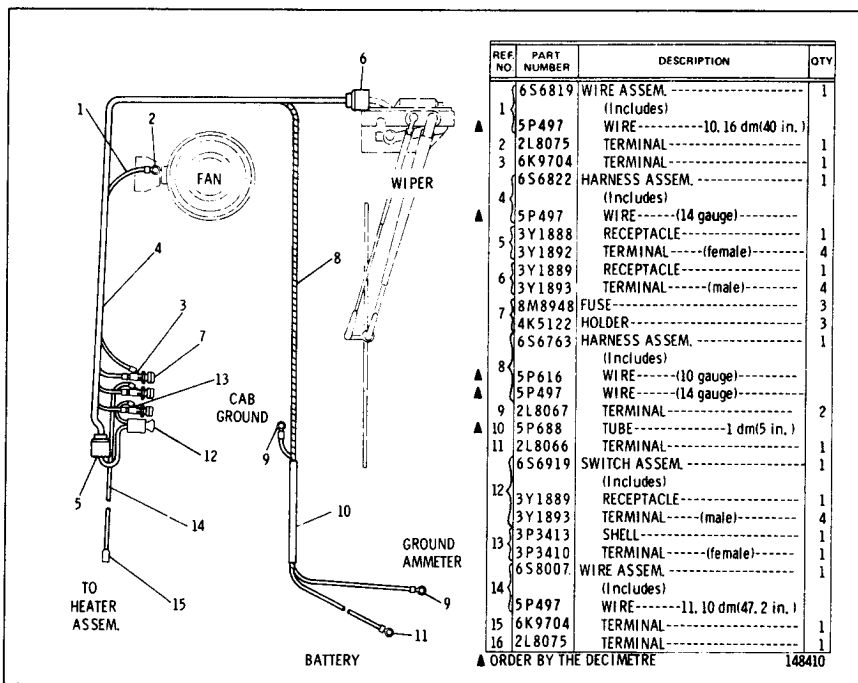

6S8561 CAB WIRING GROUP—Type 1  
Part of 6S8475 and 6S8476 Cab Arrangements listed on Pages 89B, 90A and 90B  
AN ATTACHMENT

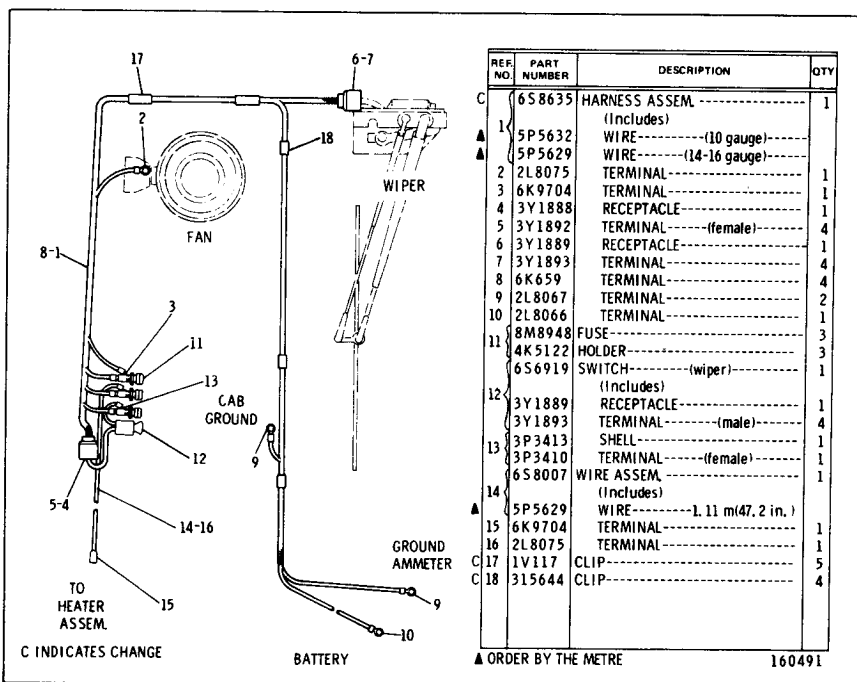

6S8561 CAB WIRING GROUP—Type 2  
Part of 6S8475 and 6S8476 Cab Arrangements listed on Pages 89B, 90A and 90B  
AN ATTACHMENT

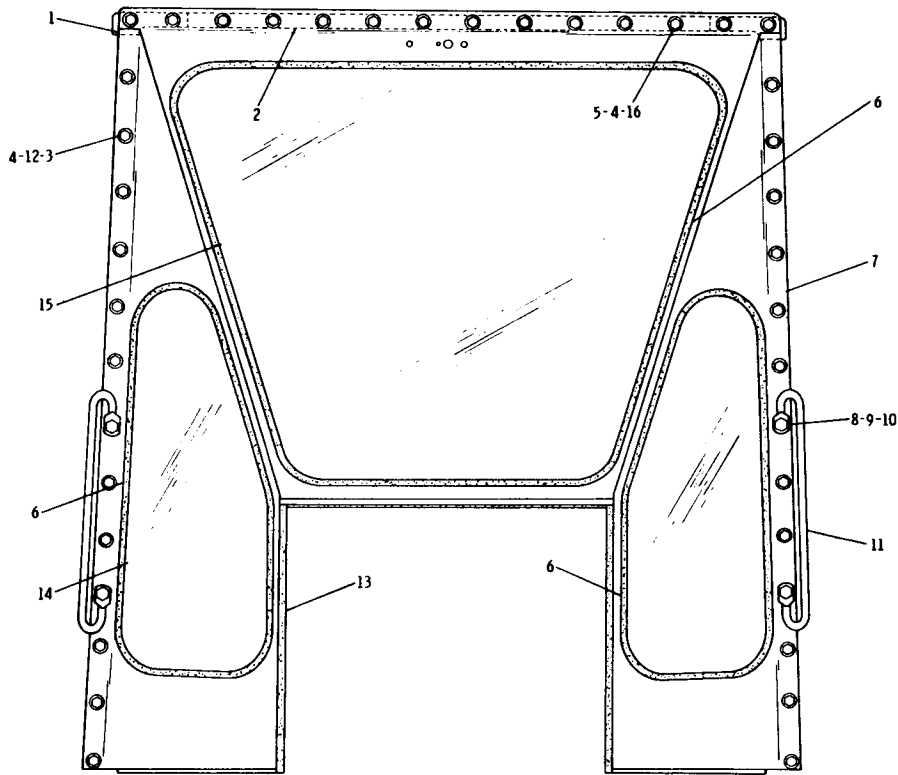

REF. NO.	PART NUMBER	DESCRIPTION	QTY
	1 6S6156	SEAL-----	2
	2 6S6190	SEAL-----	1
	3 S1615	BOLT-----	22
C	4 4B5269	WASHER-----	36
	5 6S6175	BUSHING-----	14
	6 5P822	SEAL----- (use as required)	
	7 6S7757	PANEL ASSEM.-----	1
C	8 S1595	BOLT-----	4
	9 3B4508	LOCKWASHER-----	4
	10 4B4280	WASHER-----	4
C	11 6S9101	GRAB IRON-----	2
C	12 3B4504	LOCKWASHER-----	22
C	13 5P1898	SEAL----- (use as required)	
	14 6S7710	GLASS----- (side)	2
	15 6S7756	GLASS----- (center)	1
C	16 S1616	BOLT-----	14

C INDICATES CHANGE

155277

6S7714 PANEL GROUP—Front—Type 2  
 Part of 6S6200, 6S8475, 6S7882 and 6S8476 Cab Arrangements listed on Pages 89 and 89B through 90B



6S7714 PANEL GROUP—Front—Type 1  
 Part of 6S6200, 6S8475, 6S7882, 6S8476 Arrangements listed on Pages 89, 89B, 90 and 90A

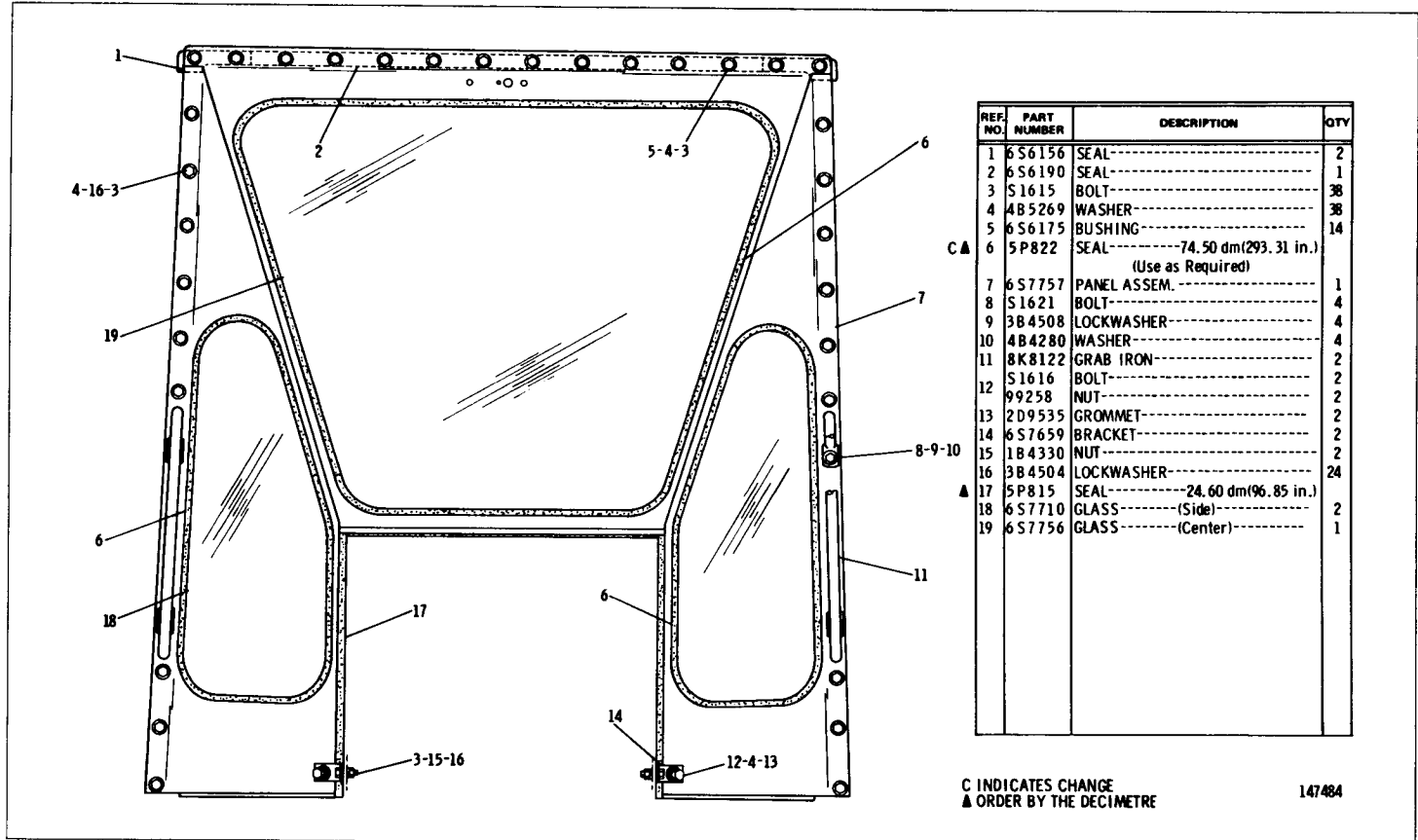

REF. NO.	PART NUMBER	DESCRIPTION	QTY
1	6S6156	SEAL-----	2
2	6S6190	SEAL-----	1
3	51615	BOLT-----	38
4	4B5269	WASHER-----	38
5	6S6175	BUSHING-----	14
C ▲ 6	5P822	SEAL-----74.50 dm(293.31 in.) (Use as Required)	
7	6S7757	PANEL ASSEM.-----	1
8	51621	BOLT-----	4
9	3B4508	LOCKWASHER-----	4
10	4B4280	WASHER-----	4
11	8K8122	GRAB IRON-----	2
12	51616	BOLT-----	2
	99258	NUT-----	2
13	2D9535	GROMMET-----	2
14	6S7659	BRACKET-----	2
15	1B4330	NUT-----	2
16	3B4504	LOCKWASHER-----	24
▲ 17	5P815	SEAL-----24.60 dm(96.85 in.)	
18	6S7710	GLASS----- (Side)	2
19	6S7756	GLASS----- (Center)	1

C INDICATES CHANGE  
 ▲ ORDER BY THE DECIMETRE

147484

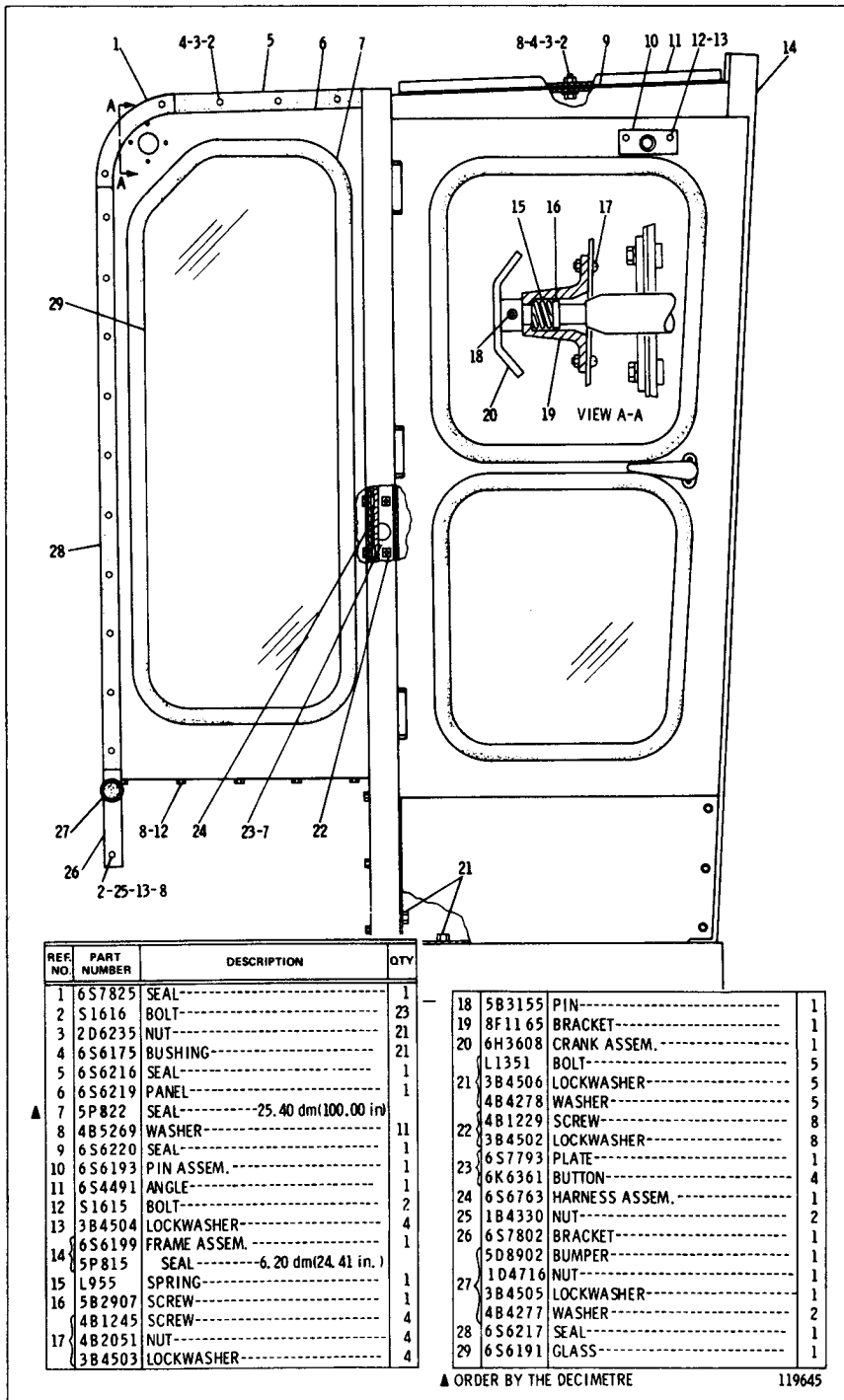

REF NO.	PART NUMBER	DESCRIPTION	QTY
1	6S7825	SEAL	1
2	S1616	BOLT	23
3	2D6235	NUT	21
4	6S6175	BUSHING	21
5	6S6216	SEAL	1
6	6S6219	PANEL	1
7	5P822	SEAL -----25.40 dm(100.00 in)	1
8	4B5269	WASHER	11
9	6S6220	SEAL	1
10	6S6193	PIN ASSEM.	1
11	6S4491	ANGLE	1
12	S1615	BOLT	2
13	3B4504	LOCKWASHER	4
14	6S6199	FRAME ASSEM.	1
15	5P815	SEAL -----6.20 dm(24.41 in.)	1
16	L955	SPRING	1
17	4B2051	NUT	4
18	3B4503	LOCKWASHER	4

18	5B3155	PIN	1
19	8F1165	BRACKET	1
20	6H3608	CRANK ASSEM.	1
	L1351	BOLT	5
21	3B4506	LOCKWASHER	5
	4B4278	WASHER	5
	4B1229	SCREW	8
22	3B4502	LOCKWASHER	8
	6S7793	PLATE	1
23	6K6361	BUTTON	4
	6S6763	HARNESS ASSEM.	1
24	1B4330	NUT	2
26	6S7802	BRACKET	1
	5D8902	BUMPER	1
	1D4716	NUT	1
27	3B4505	LOCKWASHER	1
	4B4277	WASHER	2
28	6S6217	SEAL	1
29	6S6191	GLASS	1

6S6226 PANEL GROUP—R.H.—Part 1—Type 1  
 Part of 6S6200, 6S8475, 6S7882 and 6S8476 Cab Arrangements listed  
 on Pages 89 and 89B through 90B

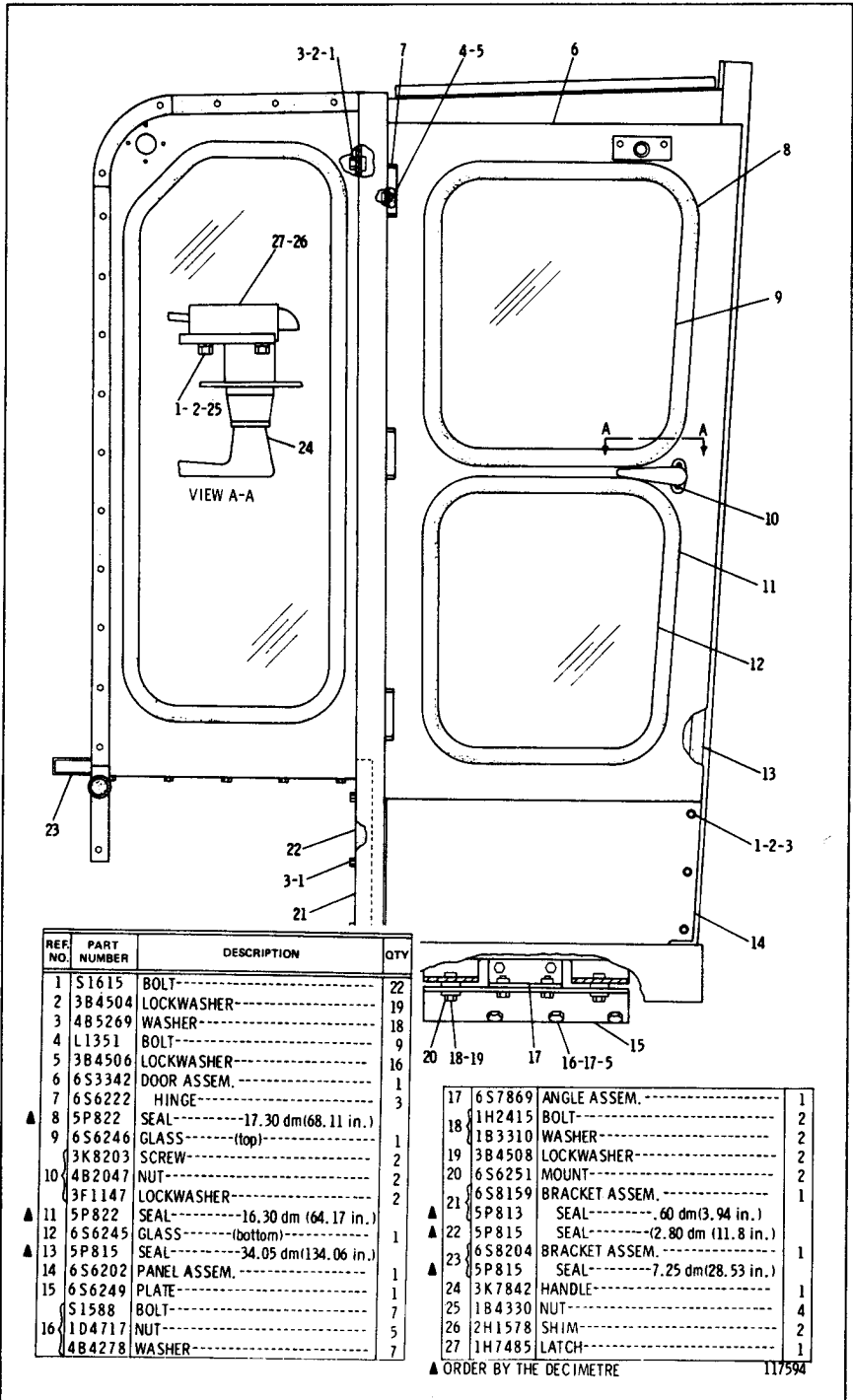

REF. NO.	PART NUMBER	DESCRIPTION	QTY
1	S 16 15	BOLT-----	22
2	3B 4 504	LOCKWASHER-----	19
3	4B 5 269	WASHER-----	18
4	L 13 51	BOLT-----	9
5	3B 4 506	LOCKWASHER-----	16
6	6S 3 342	DOOR ASSEM.-----	1
7	6S 6 222	HINGE-----	3
▲ 8	5P 8 22	SEAL-----17.30 dm (68.11 in.)	1
9	6S 6 246	GLASS----- (top)	1
10	(3K 8 203	SCREW-----	2
10	4B 2 047	NUT-----	2
10	(3F 1 147	LOCKWASHER-----	2
▲ 11	5P 8 22	SEAL-----16.30 dm (64.17 in.)	1
12	6S 6 245	GLASS----- (bottom)	1
▲ 13	5P 8 15	SEAL-----34.05 dm (134.06 in.)	1
14	6S 6 202	PANEL ASSEM.-----	1
15	6S 6 249	PLATE-----	1
16	(S 1 588	BOLT-----	7
16	(1D 4 717	NUT-----	5
16	(4B 4 278	WASHER-----	7

17	6S 7 869	ANGLE ASSEM.-----	1
18	1H 2 415	BOLT-----	2
18	1B 3 310	WASHER-----	2
19	3B 4 508	LOCKWASHER-----	2
20	6S 6 251	MOUNT-----	2
▲ 21	6S 8 159	BRACKET ASSEM.-----	1
▲ 21	5P 8 13	SEAL----- .60 dm (3.94 in.)	1
▲ 22	5P 8 15	SEAL----- (2.80 dm (11.8 in.)	1
▲ 23	6S 8 204	BRACKET ASSEM.-----	1
▲ 23	5P 8 15	SEAL-----7.25 dm (28.53 in.)	1
24	3K 7 842	HANDLE-----	1
25	1B 4 330	NUT-----	4
26	2H 1 578	SHIM-----	2
27	1H 7 485	LATCH-----	1

▲ ORDER BY THE DECIMETRE

117594

6S6226 PANEL GROUP—R.H.—Part 2—Type 1  
 Part of 6S6200, 6S8475, 6S7882 and 6S8476 Cab Arrangements  
 listed on Pages 89 and 89B through 90B

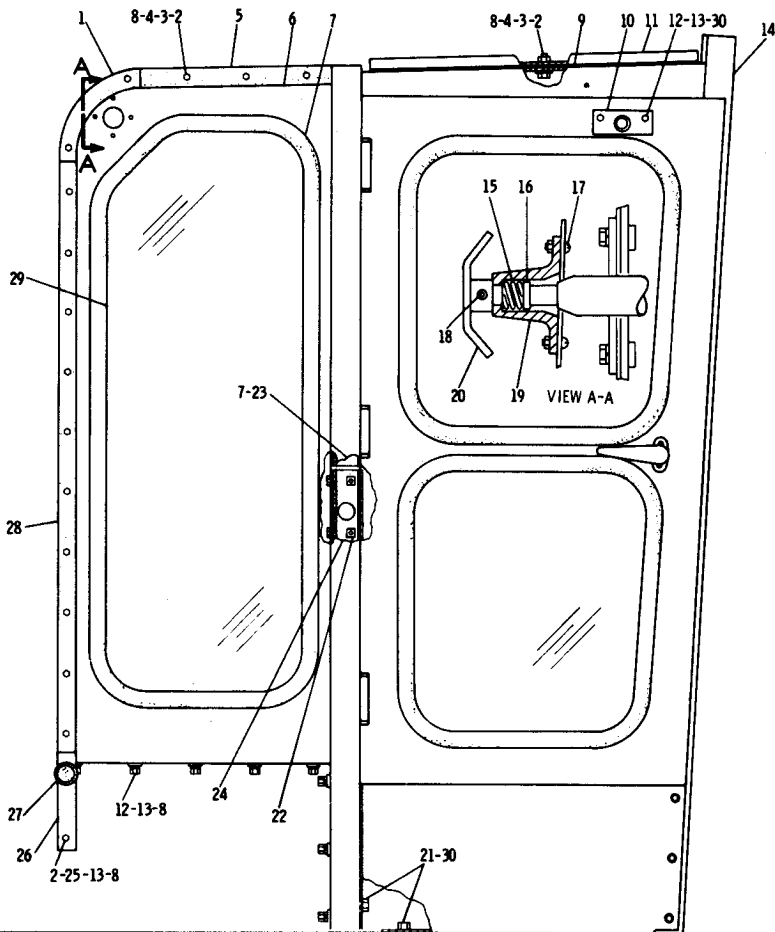

REF. NO.	PART NUMBER	DESCRIPTION	QTY	REF. NO.	PART NUMBER	DESCRIPTION	QTY
1	6S7825	SEAL	1	18	5B3155	PIN	1
2	S1616	BOLT	23	19	8F1165	BRACKET	1
3	2D6235	NUT	21	20	6H3608	CRANK ASSEM.	1
4	6S6175	BUSHING	21	21	L1351	BOLT	5
5	6S6216	SEAL	1		3B4506	LOCKWASHER	5
6	6S6219	PANEL	1	22	4B1229	SCREW	8
7	5P5642	SEAL-----2.54 m(100 in.)	1		3B4502	LOCKWASHER	8
8	4B5269	WASHER	28	23	6S7793	PLATE	1
9	6S6220	SEAL	1		3L4566	BUTTON	1
10	6S6193	PIN ASSEM.	1	C 24	6S7790	PLATE	1
11	6S4491	ANGLE	1	25	1B4330	NUT	2
12	S1615	BOLT	7	26	6S7802	BRACKET	1
13	3B4504	LOCKWASHER	9		5D8902	BUMPER	1
14	6S6199	FRAME ASSEM.	1	27	1B4202	NUT	1
15	5P5934	SEAL-----620 m(24, 41 in.)	1		3B4505	LOCKWASHER	1
16	L955	SPRING	1		4B4277	WASHER	2
17	5B2907	SCREW	1	28	6S6217	SEAL	1
	4B1244	SCREW	4	29	6S6191	GLASS	1
	4B2051	NUT	4	C 30	4B4278	WASHER	7
	3B4503	LOCKWASHER	4				

C INDICATES CHANGE

▲ ORDER BY THE METRE

217311

6S6226 PANEL GROUP—R.H.—Part 1—Type 2  
 Part of 6S6200, 6S8475, 6S7882 and 6S8476 Cab Arrangements  
 listed on Pages 89 and 89B through 90B

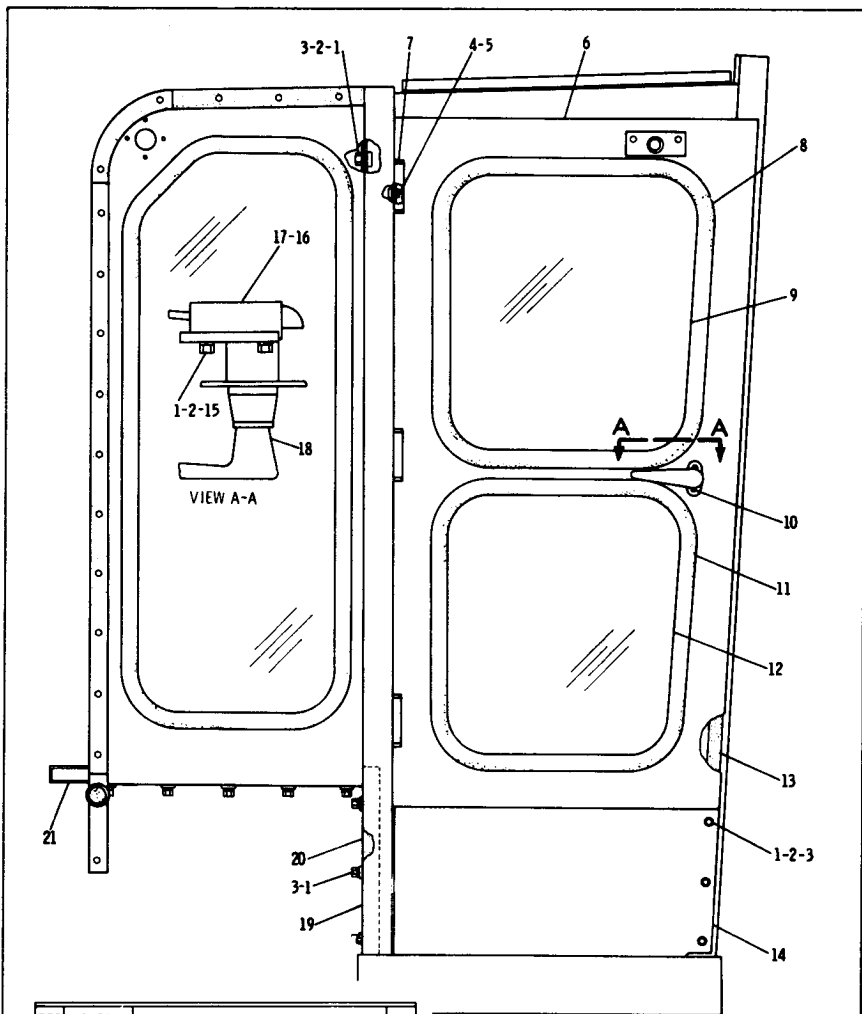

REF. NO.	PART NUMBER	DESCRIPTION	QTY
1	S1615	BOLT	22
C 2	3B4504	LOCKWASHER	22
3	4B5269	WASHER	18
4	L1351	BOLT	9
C 5	3B4506	LOCKWASHER	9
6	6S3342	DOOR ASSEM. (Includes)	1
C 6	6D4299	NUT	2
7	6S6222	HINGE	3
CA 8	5P5642	SEAL-----1.73 m(68.11 in.)	
9	6S6246	GLASS------(top)	1
C 10	2H6120	SCREW	2
10	3F1147	LOCKWASHER	2
CA 11	5P5642	SEAL-----1.63 m(64.17 in.)	
12	6S6245	GLASS------(bottom)	1
CA 13	5P5934	SEAL-----3.24 m(127.60 in.)	
14	6S6202	PANEL ASSEM.	1

C INDICATES CHANGE

15	1B4330	NUT	4
16	2H1578	SHIM	2
17	1H7485	LATCH	1
18	3K7842	HANDLE	1
18		(Includes)	
C 18	5K4340	KEY	2
19	6S8159	BRACKET ASSEM. (Includes)	1
19	5P5933	SEAL-----1 m(3.94 in.)	
CA 20	5P5934	SEAL-----3 m(11.8 in.)	
20	6S8204	BRACKET ASSEM. (Includes)	1
21	5P5934	SEAL-----.725 m(28.53 in.)	

▲ ORDER BY THE METRE

217312

6S6226 PANEL GROUP—R.H.—Part 2—Type 2  
Part of 6S6200, 6S8475, 6S7882 and 6S8476 Cab Arrangements  
listed on Pages 89 and 89B through 90B

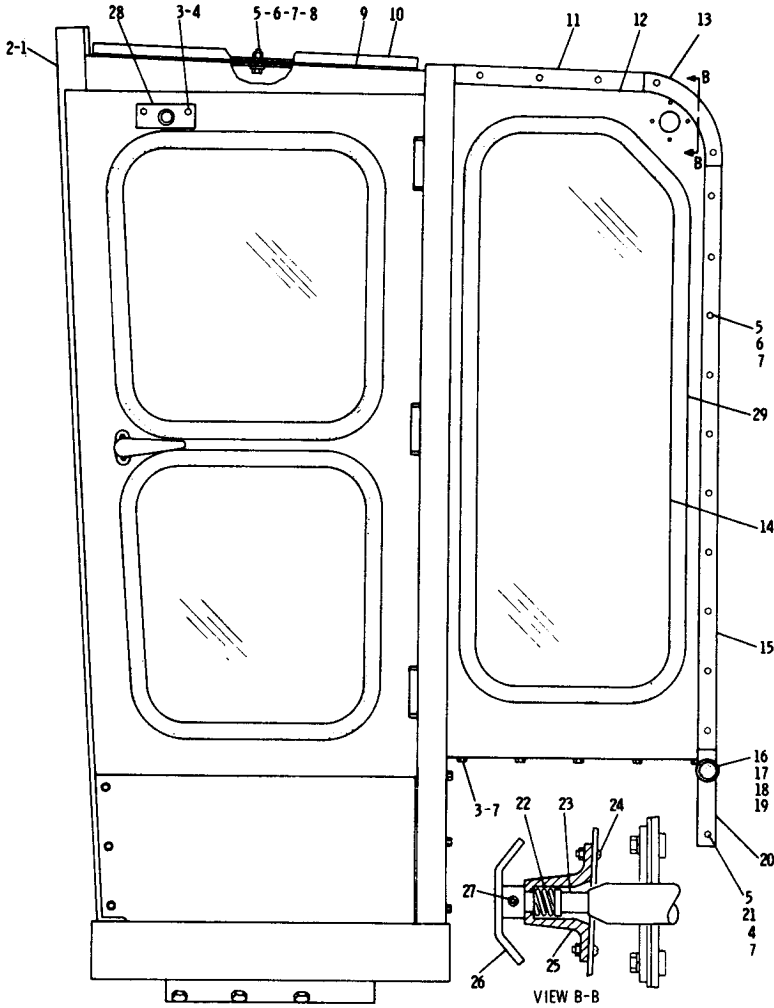

REF. NO.	PART NUMBER	DESCRIPTION	QTY
1	6S6207	FRAME ASSEM.-----	1
2	5P815	SEAL-----6.20 dm(24.41 in.)	1
3	51615	BOLT-----	7
4	3B4504	LOCKWASHER-----	4
5	51616	BOLT-----	23
6	2D6235	NUT-----	21
7	4B5269	WASHER-----	28
8	6S6175	BUSHING-----	6
9	6S6220	SEAL-----	1
10	6S4491	ANGLE-----	1
11	6S6216	SEAL-----	1
12	6S6229	PANEL-----	1
13	6S7825	SEAL-----	1
14	6S6191	GLASS-----	1
15	6S6217	SEAL-----	1

C INDICATES CHANGE

16	5D8902	BUMPER-----	1
17	1D4716	NUT-----	1
18	3B4505	LOCKWASHER-----	1
19	4B4277	WASHER-----	2
20	6S7802	BRACKET-----	1
21	1B4330	NUT-----	2
22	L955	SPRING-----	1
23	5B2907	SCREW-----	1
	(4B1245	SCREW-----	4
24	4B2051	NUT-----	4
	(3B4503	LOCKWASHER-----	4
25	8F1165	BRACKET-----	1
26	6H3608	CRANK ASSEM.-----	1
27	5B3155	PIN-----	1
28	6S7779	PIN ASSEM.-----	1
▲ 29	5P822	SEAL-----25.40 dm(100 in.)	1

▲ ORDER BY THE DECIMETRE

119646

6S6227 PANEL GROUP—L.H.—Part 1—Type 1  
 Part of 6S6200, 6S8475, 6S7882 and 6S8476 Cab Arrangements  
 listed on Pages 89 and 89B through 90B

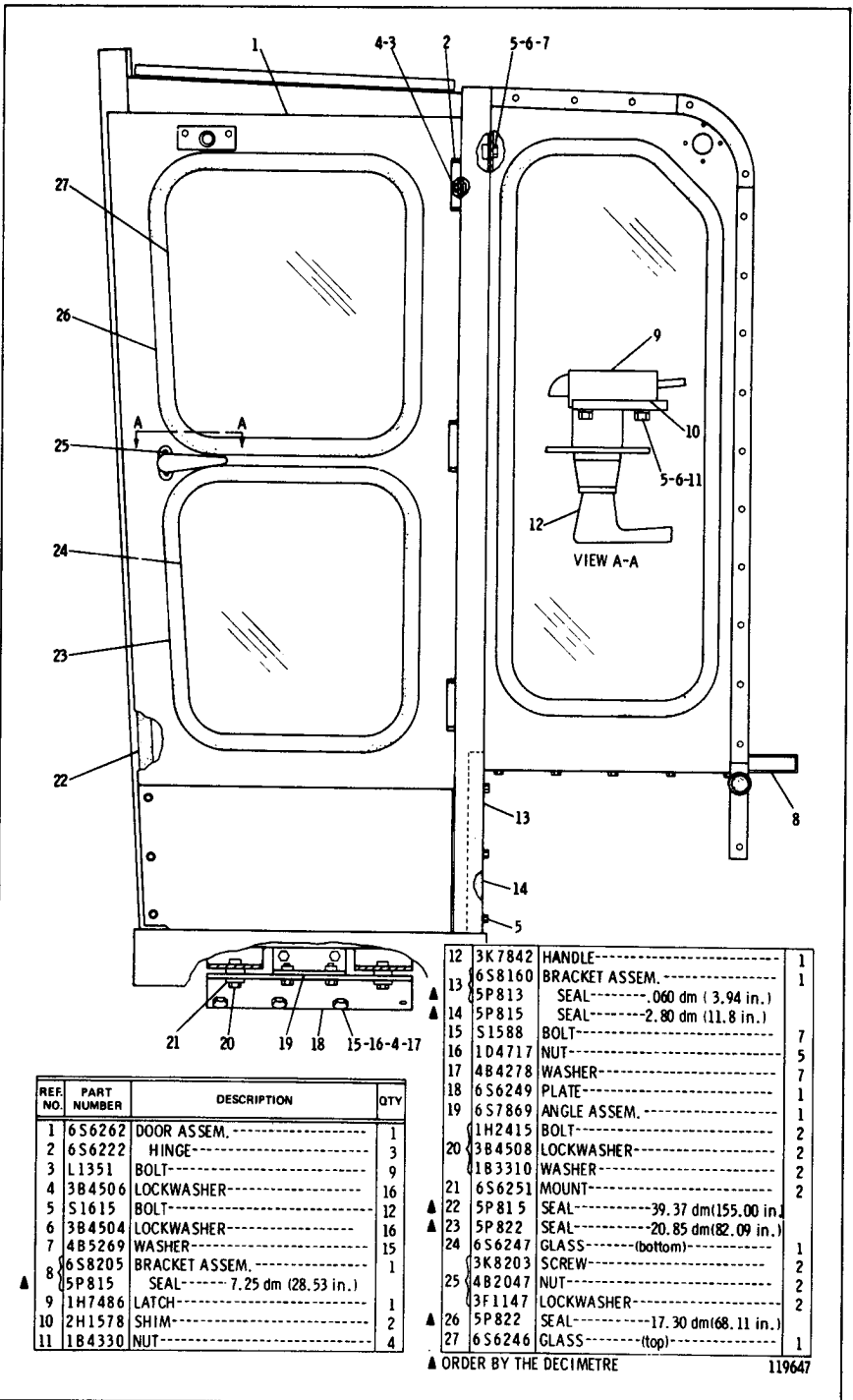

REF. NO.	PART NUMBER	DESCRIPTION	QTY
1	6S6262	DOOR ASSEM.-----	1
2	6S6222	HINGE-----	3
3	L1351	BOLT-----	9
4	3B4506	LOCKWASHER-----	16
5	S1615	BOLT-----	12
6	3B4504	LOCKWASHER-----	16
7	4B5269	WASHER-----	15
8	6S8205	BRACKET ASSEM.-----	1
▲ 8	5P815	SEAL-----7.25 dm (28.53 in.)	2
9	1H7486	LATCH-----	1
10	2H1578	SHIM-----	2
11	1B4330	NUT-----	4

12	3K7842	HANDLE-----	1
13	6S8160	BRACKET ASSEM.-----	1
14	5P813	SEAL-----0.60 dm (3.94 in.)	1
14	5P815	SEAL-----2.80 dm (11.8 in.)	1
15	S1588	BOLT-----	7
16	1D4717	NUT-----	5
17	4B4278	WASHER-----	7
18	6S6249	PLATE-----	1
19	6S7869	ANGLE ASSEM.-----	1
▲ 19	1H2415	BOLT-----	2
20	3B4508	LOCKWASHER-----	2
▲ 20	1B3310	WASHER-----	2
▲ 21	6S6251	MOUNT-----	2
▲ 22	5P815	SEAL-----39.37 dm (155.00 in.)	1
▲ 23	5P822	SEAL-----20.85 dm (82.09 in.)	1
24	6S6247	GLASS----- (bottom)	1
▲ 24	3K8203	SCREW-----	2
25	4B2047	NUT-----	2
▲ 25	3F1147	LOCKWASHER-----	2
▲ 26	5P822	SEAL-----17.30 dm (68.11 in.)	1
27	6S6246	GLASS----- (top)	1

▲ ORDER BY THE DECIMETRE

119647

6S6227 PANEL GROUP—L.H.—Part 2—Type 1  
 Part of 6S6200, 6S8475, 6S7882 and 6S8476 Cab Arrangements  
 listed on Pages 89 and 89B through 90B

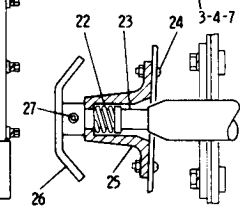
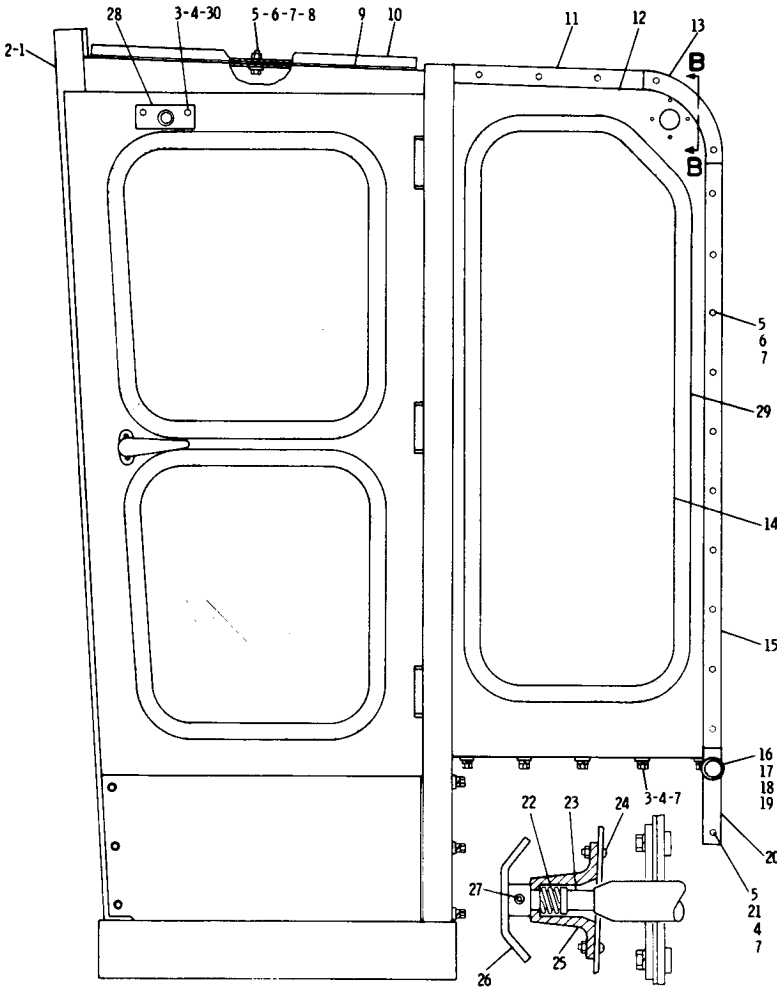

REF. NO.	PART NUMBER	DESCRIPTION	QTY
1	6S6207	FRAME ASSEM.	1
▲ 2	5P815	SEAL-----6.20 dm(24.41 in.)	1
3	51615	BOLT	7
C 4	3B4504	LOCKWASHER	12
5	51616	BOLT	23
6	2D6235	NUT	21
C 7	4B5269	WASHER	31
8	6S6175	BUSHING	6
9	6S6220	SEAL	1
10	6S4491	ANGLE	1
11	6S6216	SEAL	1
12	6S6229	PANEL	1
13	6S7825	SEAL	1
14	6S6191	GLASS	1
15	6S6217	SEAL	1

16	5D8902	BUMPER	1
C 17	1B4202	NUT	1
18	3B4505	LOCKWASHER	1
19	4B4277	WASHER	2
20	6S7802	BRACKET	1
21	1B4330	NUT	2
22	1L955	SPRING	1
23	5B2907	SCREW	1
C 24	4B1244	SCREW	4
24	4B2051	NUT	4
	3B4503	LOCKWASHER	4
25	8F1165	BRACKET	1
26	6H3608	CRANK ASSEM.	1
27	5B3155	PIN	1
28	6S7779	PIN ASSEM.	1
▲ 29	5P822	SEAL-----25.40 dm(100 in.)	1
C 30	4B4278	WASHER	2

C INDICATES CHANGE

▲ ORDER BY THE DECIMETRE

207309

6S6227 PANEL GROUP—L.H.—Part 1—Type 2  
 Part of 6S6200, 6S8475, 6S7882 and 6S8476 Cab Arrangements  
 listed on Pages 89 and 89B through 90B



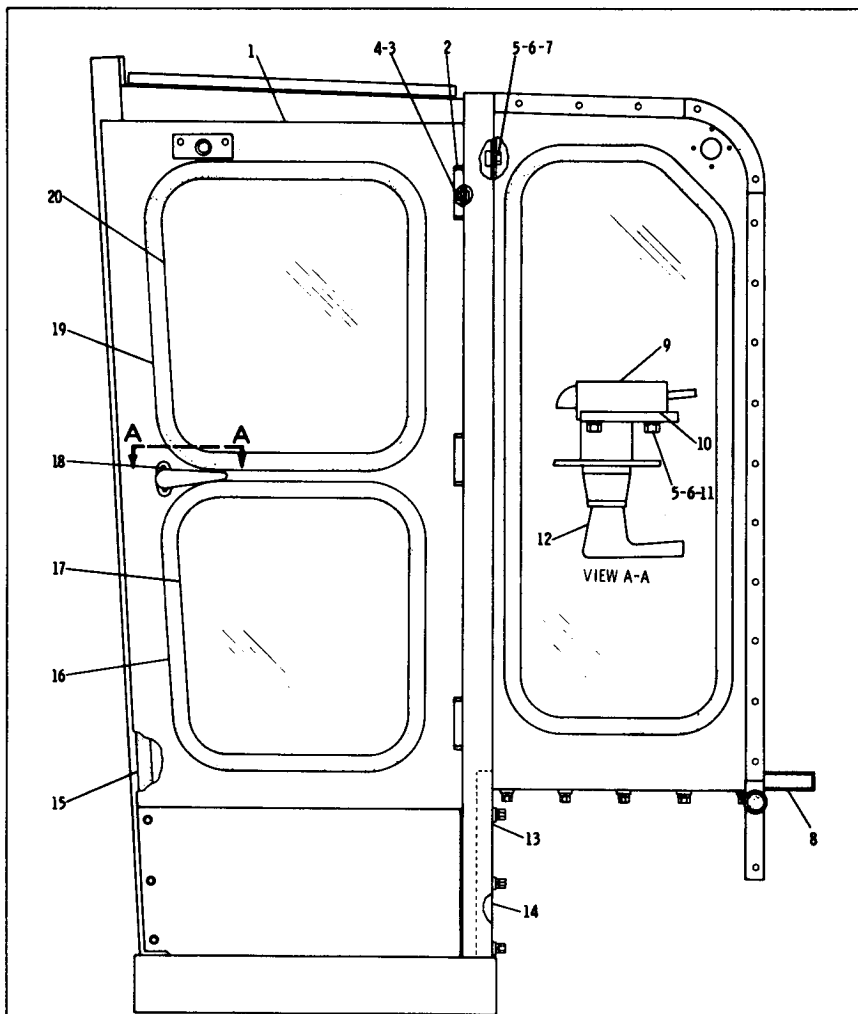

REF. NO.	PART NUMBER	DESCRIPTION	QTY
	6S6262	DOOR ASSEM. -----	1
		(Includes)	
1	6D4299	NUT -----	2
2	6S6222	HINGE -----	3
3	L1351	BOLT -----	9
4	3B4506	LOCKWASHER -----	9
5	S1615	BOLT -----	12
6	3B4504	LOCKWASHER -----	16
7	4B5269	WASHER -----	12
8	6S8205	BRACKET ASSEM. -----	1
		(Includes)	
▲	5P5934	SEAL -----, 72 m(28, 53 in.)	
9	1H7486	LATCH -----	1
10	2H1578	SHIM -----	2
11	1B4330	NUT -----	4

C INDICATES CHANGE

12	3K7842	HANDLE -----	1
		(Includes)	
C	5K4340	KEY -----	2
	6S8160	BRACKET ASSEM. -----	1
		(Includes)	
▲	5P5933	SEAL -----, .006 m(3, 94 in.)	
▲	5P5934	SEAL -----, 280 m(11, 8 in.)	
▲	5P5934	SEAL -----, 3, 82 m(150, 50 in.)	
▲	5P5642	SEAL -----, 2, 08 m(82, 09 in.)	
▲	6S6247	GLASS -----	1
		(bottom)	
C	2H6120	SCREW -----	2
18	3F1147	LOCKWASHER -----	2
C	5P5642	SEAL -----, 1, 73 m(68, 11 in.)	
20	6S6246	GLASS -----	1
		(top)	

▲ ORDER BY THE METRE

217652

6S6227 PANEL GROUP—L.H.—Part 2—Type 2  
 Part of 6S6200, 6S8475, 6S7882 and 6S8476 Cab Arrangements  
 listed on Pages 89 and 89B through 90B

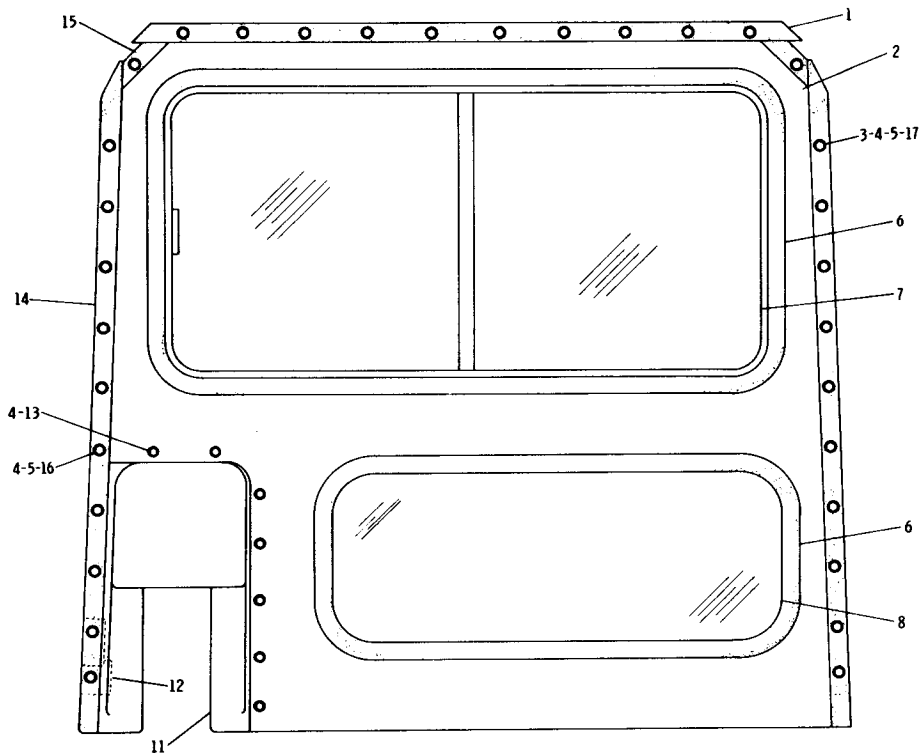

REF. NO.	PART NUMBER	DESCRIPTION	QTY
1	6S6174	SEAL-----	1
2	6S6170	PANEL ASSEM.-----	1
3	S1616	BOLT-----	31
C 4	2D6235	NUT-----	39
C 4	4B5269	WASHER-----	39
5	6S6175	BUSHING-----	32
▲ 6	5P822	SEAL-----52 dm(205 in.) (Use as Required)	
7	6S6159	GLASS-----	1
8	6S6158	GLASS-----	1
▲ 11	6S8274	SHROUD ASSEM.-----	1
▲ 11	5P815	SEAL-----9 dm(7.87 in.)	
▲ 12	6S8226	BRACKET ASSEM.-----	1
▲ 12	5P815	SEAL-----2 dm(7.87 in.)	
13	S1615	BOLT-----	7
14	6S6173	SEAL-----	2
15	6S6172	SEAL-----	2
16	9F6580	BOLT-----	1
C 17	303974	WASHER-----	4

▲ ORDER BY THE DECIMETRE

● NOT SHOWN

C INDICATES CHANGE

155278

## 6S6224 PANEL GROUP—Rear

Part of 6S6200, 6S8475, 6S7882 and 6S8476 Cab Arrangements listed on Pages 89 and 89B through 90B

6S8575 CAB MOUNTING GROUP  
 Part of 6S8573 Operator Protective Cab Arrangement listed on Page 89A

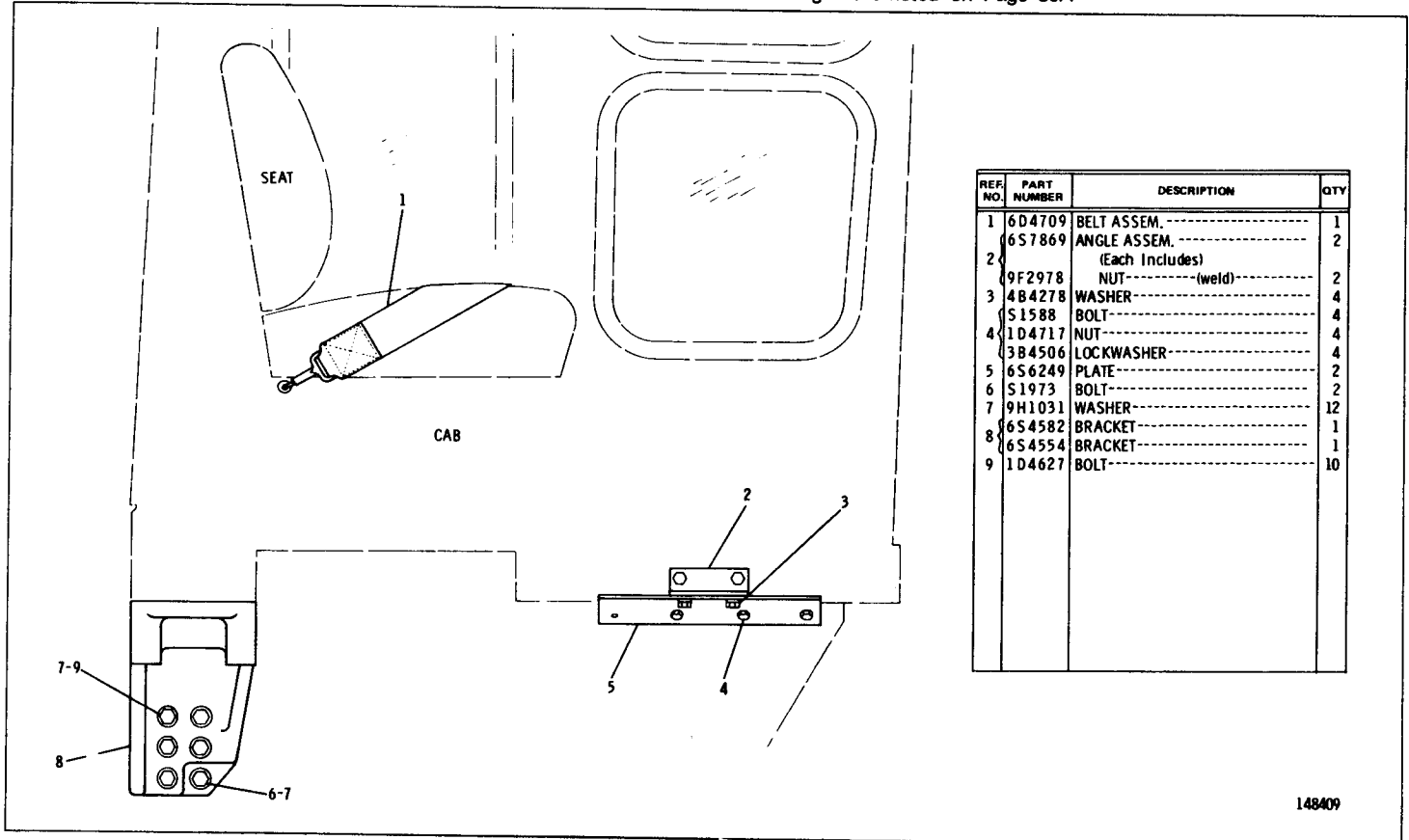

REF. NO.	PART NUMBER	DESCRIPTION	QTY
1	6D4709	BELT ASSEM.-----	1
	6S7869	ANGLE ASSEM.-----	2
2		(Each Includes)	
	9F2978	NUT----- (weld)-----	2
3	4B4278	WASHER-----	4
	S1588	BOLT-----	4
4	1D4717	NUT-----	4
	3B4506	LOCKWASHER-----	4
5	6S6249	PLATE-----	2
6	S1973	BOLT-----	2
7	9H1031	WASHER-----	12
8	6S4582	BRACKET-----	1
	6S4554	BRACKET-----	1
9	1D4627	BOLT-----	10

148409

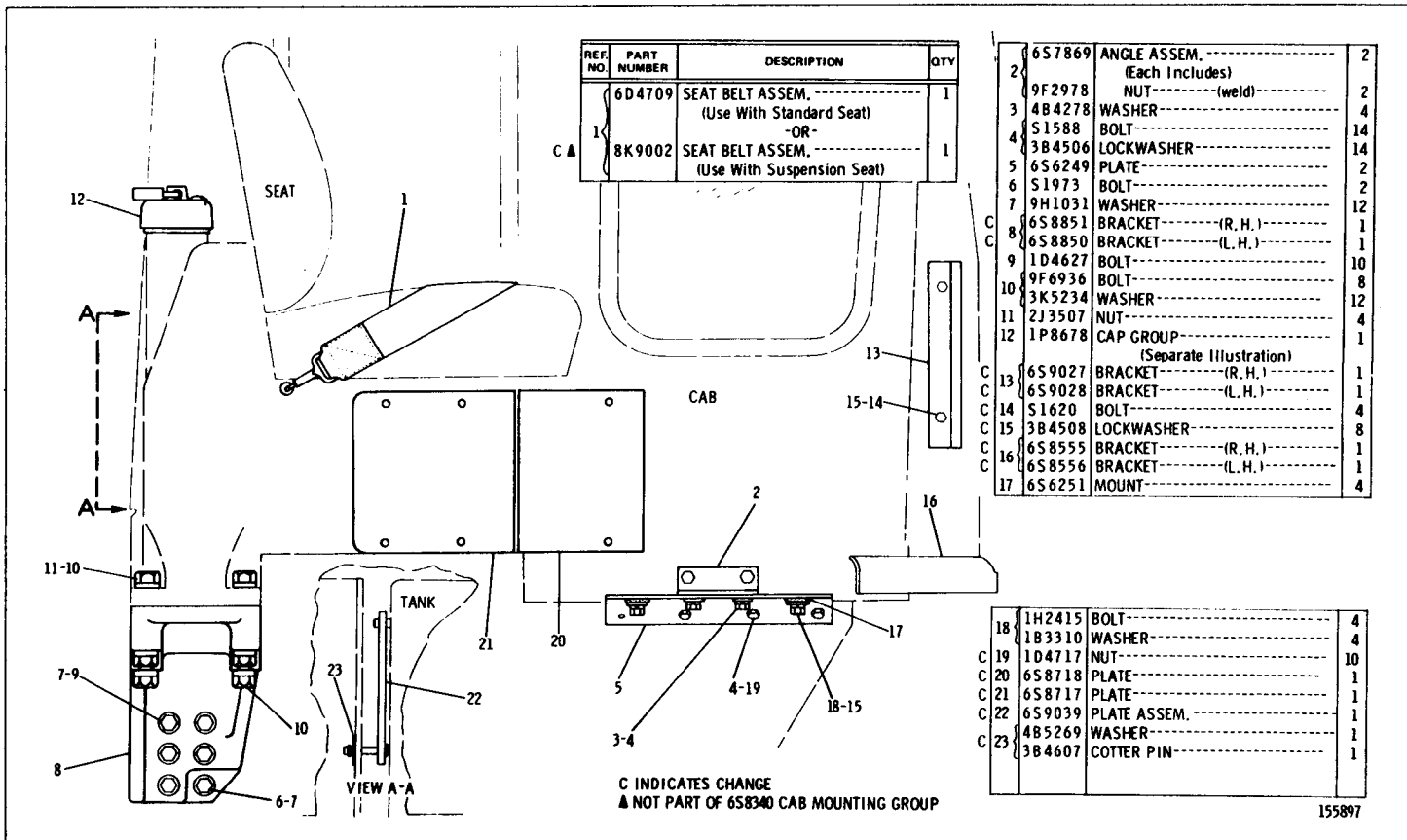

## 6S8340 CAB MOUNTING GROUP

Part of 6S8338 Operator Protective Cab Arrangement listed on Page 89A  
 1P8678 Cover parts are shown on Page 20

6S8340 CAB MOUNTING GROUP—Type 2  
 Part of 6S8338 Operator Protective Cab Arrangement listed on Page 89A  
 1P8678 Fuel Tank Cap parts are shown on Page 20

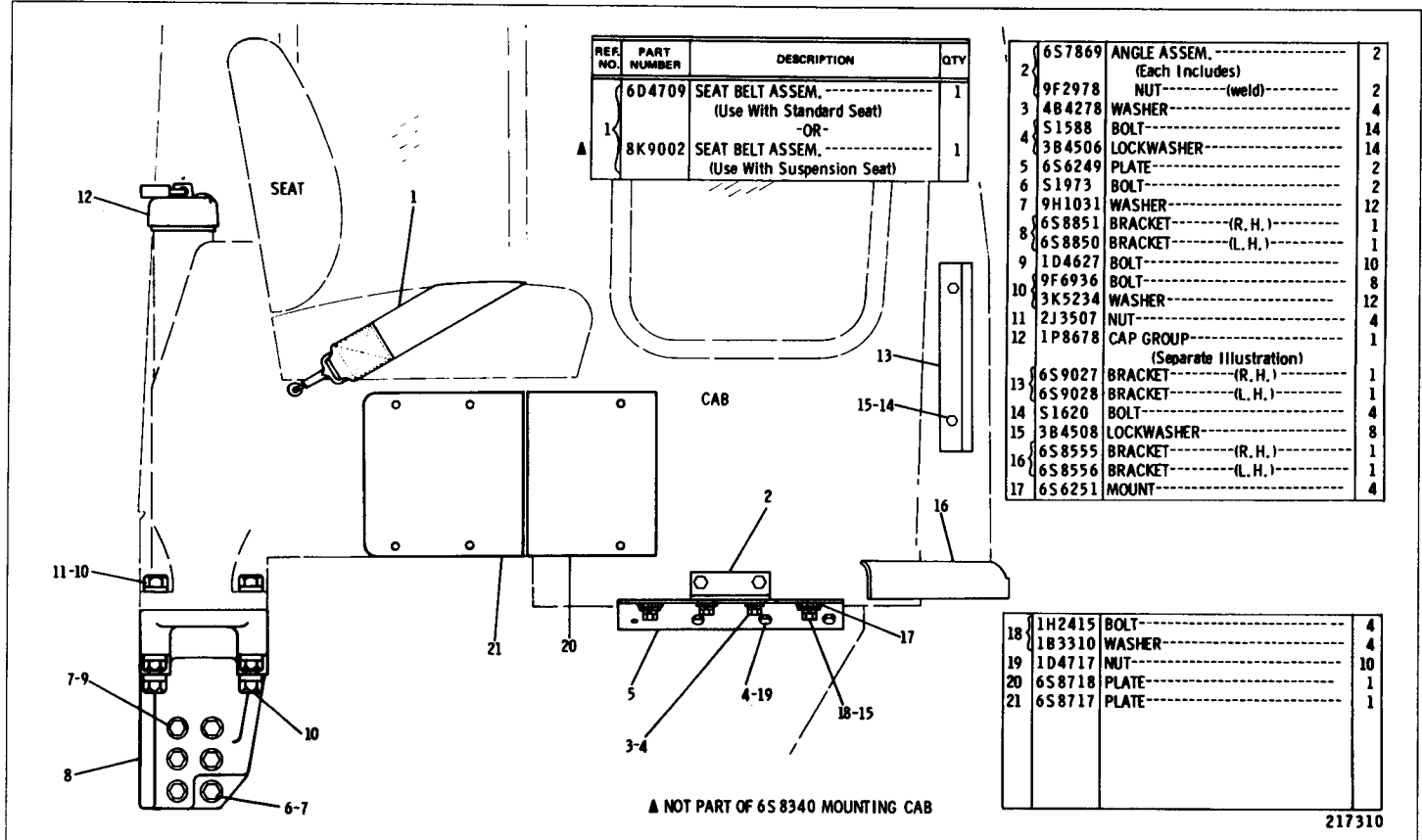

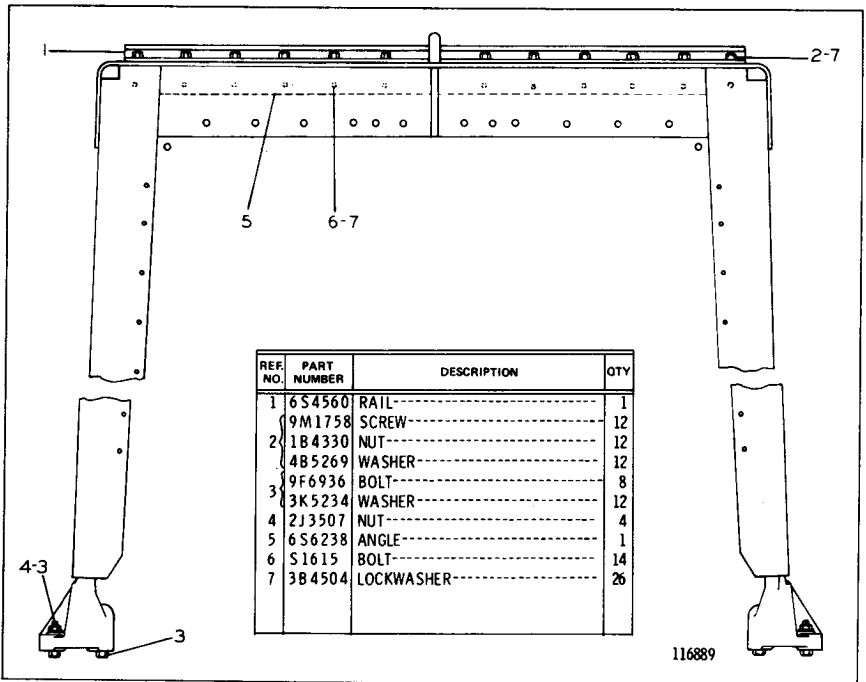

**6S5810 ROLL-OVER PROTECTIVE STRUCTURE GROUP—Type 1**  
 Part of 6S8475 and 6S4618 Operator Protective Arrangements  
 listed on Pages 89B and 90. AN ATTACHMENT

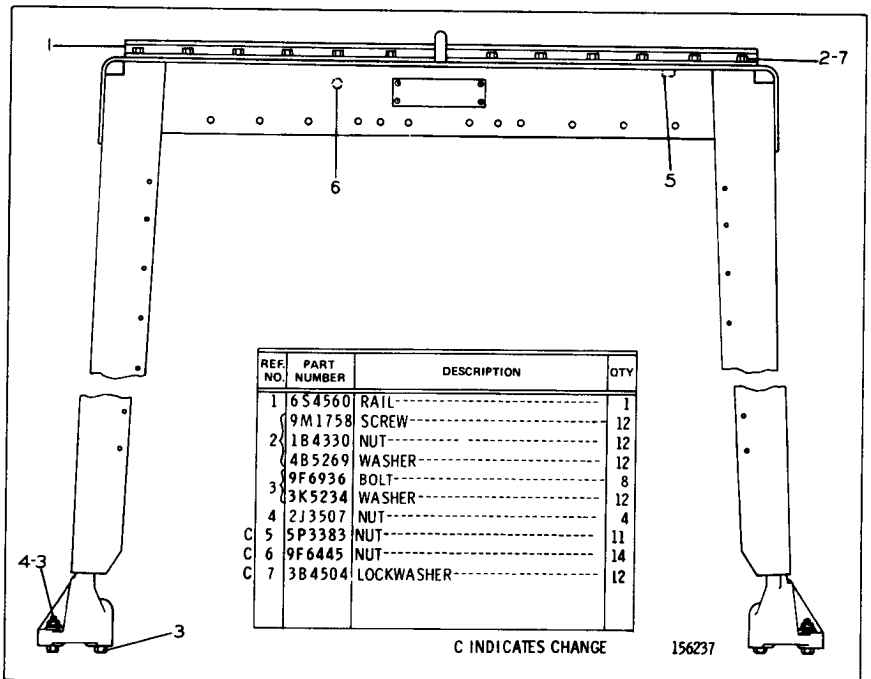

C INDICATES CHANGE

156237

**6S5810 ROLL-OVER PROTECTIVE STRUCTURE GROUP—Type 2**  
 Also part of 6S8475 & 6S4618 Operator Protective Arrangements  
 listed on Pages 89B and 90. AN ATTACHMENT

MOUNTED TO BEVEL GEAR CASE

MOUNTED ON SEAT FRAME

REF NO	PART NUMBER	DESCRIPTION	QTY
C 1	6S8850	BRACKET----- (R. H.)-----	1
C 2	6S8851	BRACKET----- (L. H.)-----	1
3	6D4709	SEAT BELT ASSEM.-----	1
4	51973	BOLT-----50.80 mm(2 in.) long	2
5	9H1031	WASHER-----	12
6	1D4627	BOLT-----76.20 mm(3 in.) long	10
▲ 7	8K9002	SEAT BELT ASSEM.-----	1

▲ NOT PART OF 6S3551 MOUNTING-USE WITH SUSPENSION SEAT

C INDICATES CHANGE

217301

**6S3551 ROLL-OVER PROTECTIVE STRUCTURE MOUNTING GROUP**  
 Also part of 6S4618 Operator Protective Arrangement listed on Page 90  
**AN ATTACHMENT**

REF NO	PART NUMBER	DESCRIPTION	QTY
1	9M1758	SCREW-----	4
1	1B4330	NUT-----	4
1	3B4504	LOCKWASHER-----	4
1	4B5269	WASHER-----	4
2	6S9560	RAIL-----	1
C 3	6D6812	KNOB ASSEM.-----	2
C 4	1D4676	BOLT-----	2
C 5	5P6875	MIRROR-----	1
6	9F6936	BOLT-----	8
6	3K5234	WASHER-----	12
7	2J3507	NUT-----	4
8	5P3383	NUT-----	11

C INDICATES CHANGE

217434

**6S5810 ROLL-OVER PROTECTIVE STRUCTURE GROUP—Type 3**  
 Also part of 6S8475 and 6S4618 Operator Protective Arrangements  
 listed on Pages 89B and 90. **AN ATTACHMENT**

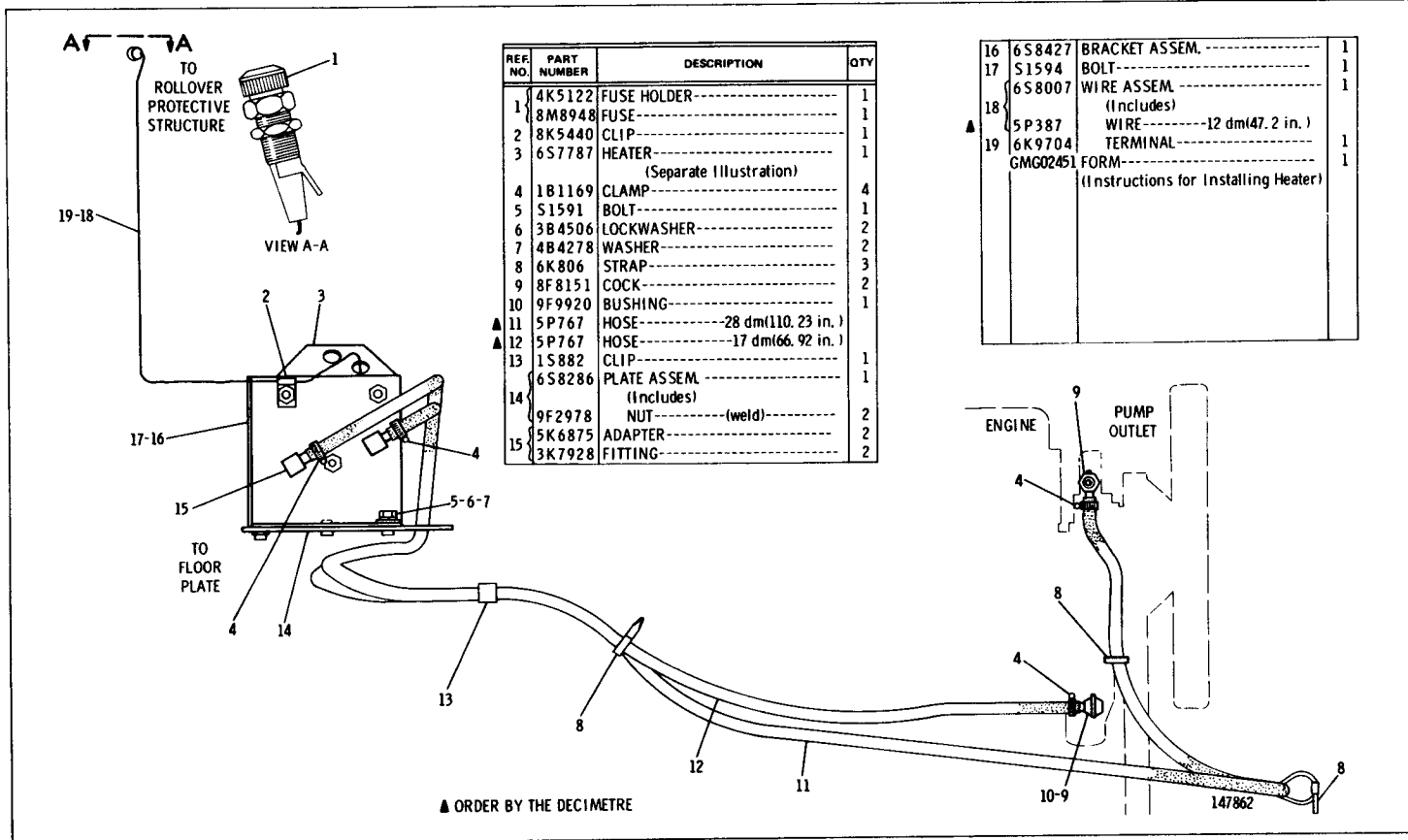

6S6784 CAB HEATER GROUP—12 Volt—Type 1  
 6S7787 Heater parts are shown on Page 98B  
 AN ATTACHMENT



6S6784 CAB HEATER GROUP—12 Volt—Type 2  
 6S7787 Heater parts are shown on Page 98B  
 AN ATTACHMENT

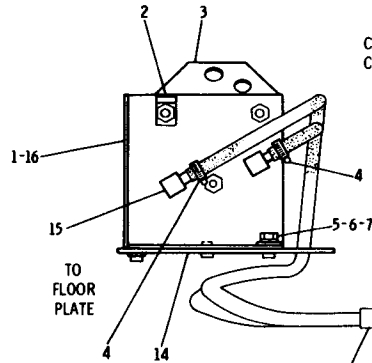

REF. NO.	PART NUMBER	DESCRIPTION	QTY
1	S1594	BOLT-----	1
2	8K5440	CLIP-----	1
3	6S7787	HEATER----- (Separate Illustration)	1
4	1B1169	CLAMP-----	4
5	S1591	BOLT-----	1
6	3B4506	LOCKWASHER-----	2
7	4B4278	WASHER-----	2
8	6K806	STRAP-----	3
9	8F8151	COCK-----	2
10	9F9920	BUSHING-----	1
C ▲ 11	5P767	HOSE-----280 cm(110.23 in.)	
C ▲ 12	5P767	HOSE-----170 cm(66.92 in.)	
13	1S882	CLIP-----	1
	6S8286	PLATE ASSEM.----- (Includes)	1
14	9F2978	NUT----- (weld)	2
15	5K6875	ADAPTER-----	2
	3K7928	FITTING-----	2

16	6S8427	BRACKET ASSEM.-----	1
	6M602451	FORM----- (Instructions for Installing Heater)	1

C INDICATES CHANGE  
 ▲ ORDER BY THE CENTIMETRE

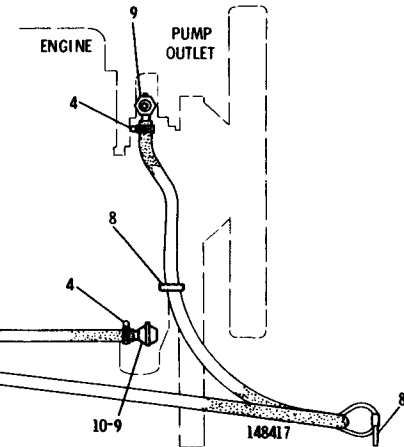

6S6784 CAB HEATER GROUP—12 Volt—Type 3  
 6S7787 Heater parts are shown on Page 98B. AN ATTACHMENT

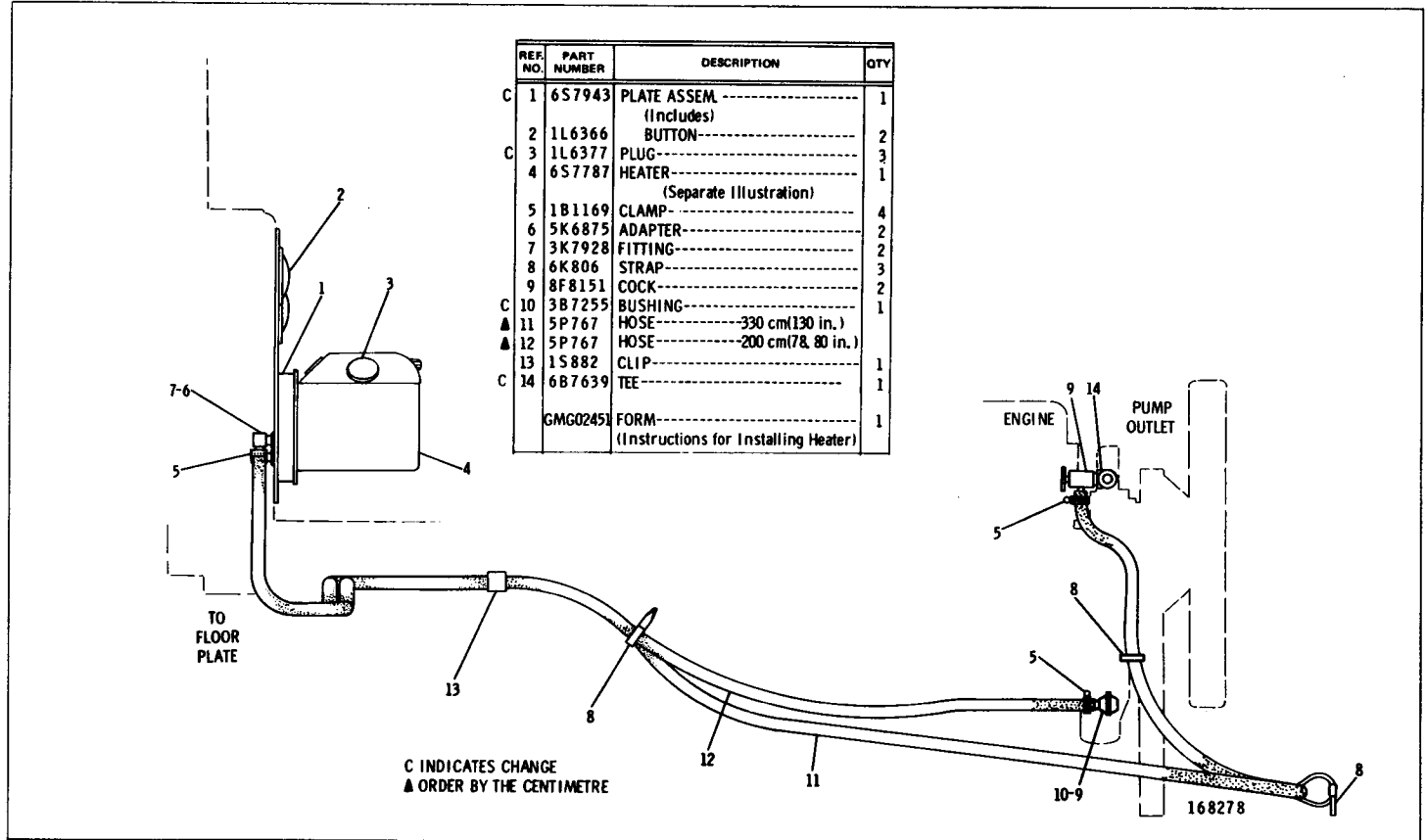

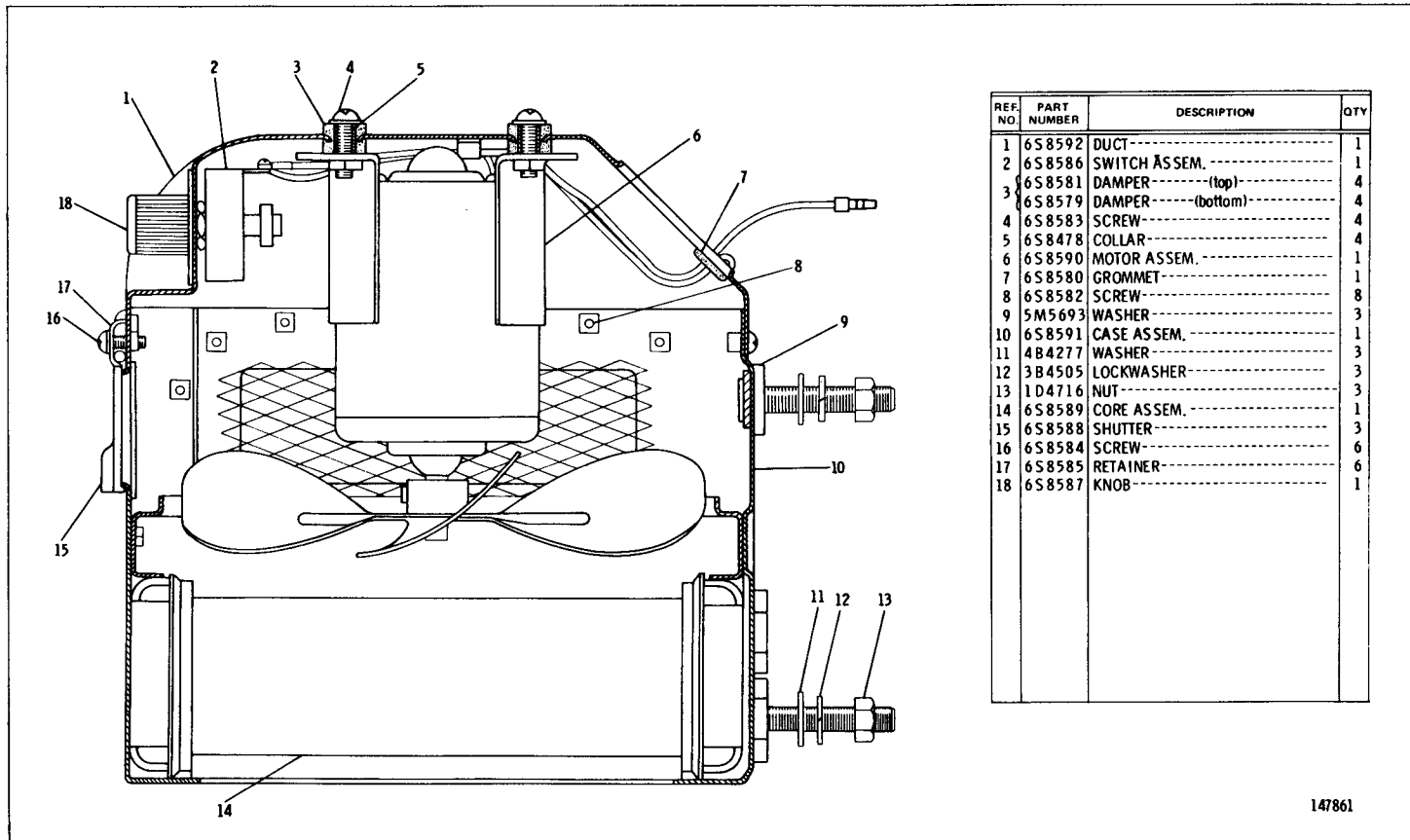

147861

6S7787 HEATER ASSEMBLY  
Part of 6S6784 Cab Heater Group shown on Pages 98 and 98A

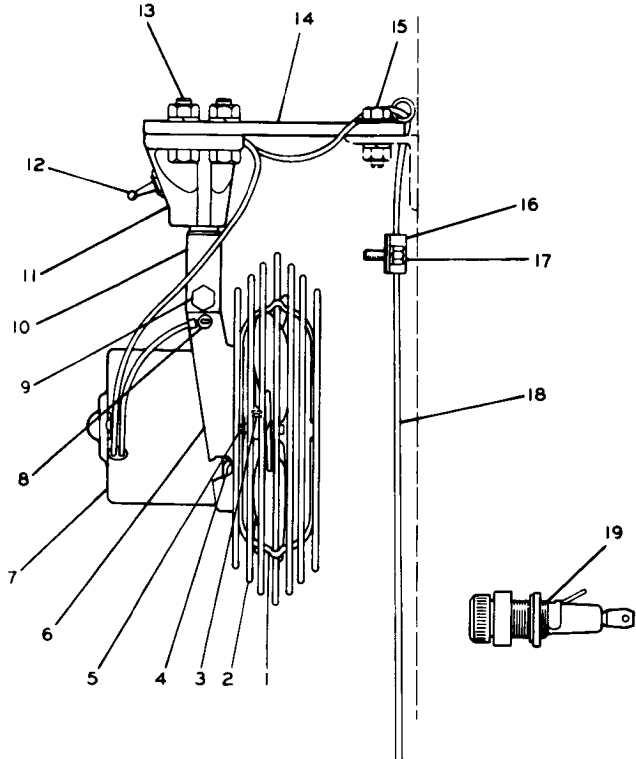

REF. NO.	PART NUMBER	DESCRIPTION	QTY
1	5D2855	FAN ASSEM. -----	1
2	3D8748	FAN ASSEM. -----	1
3	3D8749	GUARD -----	1
4	7L8316	SETSCREW -----	1
5	4D6624	WASHER -----	1
6	1M1230	NUT AND LOCK ASSEM. -----	2
7	9F9831	WASHER -----	2
8	3D8745	BRACKET -----	1
9	6D5717	MOTOR ASSEM. -----	1
10	4D128	SCREW -----	1
11	3D8761	BOLT -----	1
12	2L9038	NUT -----	1
13	4B4276	WASHER -----	4
14	3D8747	BRACKET -----	1
15	3D8743	BASE ASSEM. -----	1
16	3D8752	NUT -----	1
17	4B4277	WASHER -----	2
18	3D8754	SWITCH ASSEM. -----	1
19	5S1618	BOLT -----	4
20	1D4716	NUT -----	4
21	3B4505	LOCKWASHER -----	4
22	6S6830	BRACKET -----	1

23	5S1594	BOLT -----	2
24	3B4506	LOCKWASHER -----	2
25	8M2771	CLIP -----	2
26	2A762	BOLT -----	2
27	3B4504	LOCKWASHER -----	2
28	6S6819	WIRE ASSEM. -----	1
29	5P5629	WIRE -----1.02 m(40 in.)	1
30	2L8075	TERMINAL -----(no. 8 screw)---	1
31	6K9704	TERMINAL -----	1
32	4K5122	HOLDER -----	1
33	8M8948	FUSE -----	1
		(TO PANEL)	
34	6MG02397	FORM -----	1
		(Instructions for Installing Fan)	

C INDICATES CHANGE

▲ ORDER BY THE METRE

165690

6S6847 DEFROSTING FAN GROUP—Type 1  
For use with Operator Protective Cab Arrangement. AN ATTACHMENT

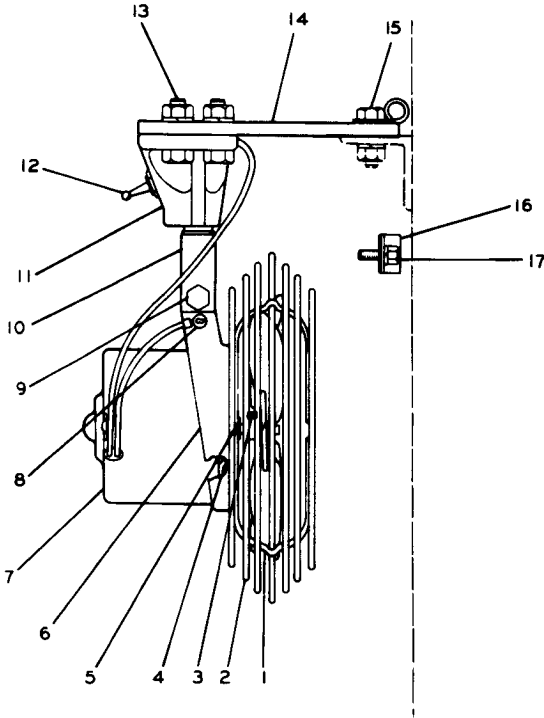

REF NO.	PART NUMBER	DESCRIPTION	QTY
1	5D2855	FAN ASSEM. ....	1
1	3D8748	FAN ASSEM. ....	1
2	3D8749	GUARD ....	1
3	7L8316	SETSCREW ....	1
4	4D6624	WASHER ....	1
5	1M1230	NUT AND LOCK ASSEM. ....	2
5	9F9831	WASHER ....	2
6	3D8745	BRACKET ....	1
7	6D5717	MOTOR ASSEM. ....	1
8	4D128	SCREW ....	1
8	3D8761	BOLT ....	1
9	2L9038	NUT ....	1
9	4B4276	WASHER ....	4
10	3D8747	BRACKET ....	1
10	3D8743	BASE ASSEM. ....	1
11	3D8752	NUT ....	1
11	4B4277	WASHER ....	2
C 12	3D8754	SWITCH ASSEM. ....	1
12	51618	BOLT ....	4
13	1D4716	NUT ....	4
13	3B4505	LOCKWASHER ....	4
14	6S6830	BRACKET ....	1

15	51594	BOLT .....	2
15	3B4506	LOCKWASHER .....	2
16	8M2771	CLIP .....	2
17	2A762	BOLT .....	2
17	3B4504	LOCKWASHER .....	2
	6MG0297	FORM .....	1
		(Instructions for Installing Fan)	

C INDICATES CHANGE

165692

6S6847 DEFROSTING FAN GROUP—Type 2  
 For use with Operator Protective Cab Arrangement. AN ATTACHMENT

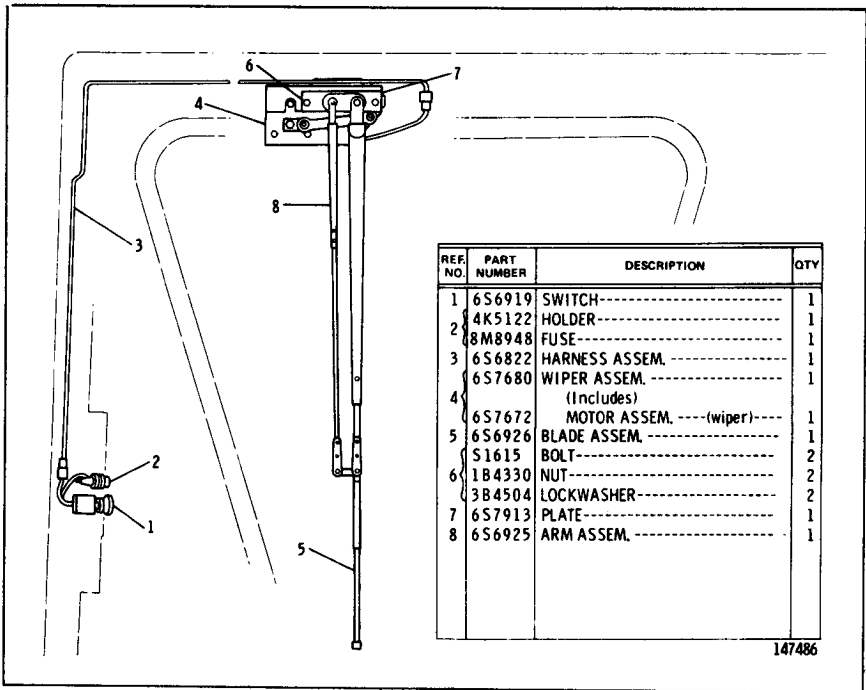

6S7697 WINDSHIELD WIPER GROUP—Type 1  
 Part of 6S8475 and 6S8476 Cab Arrangements and 6S7805 Windshield  
 Washer and Wiper Group listed on Pages 89B, 90A, 90B and 100

## CONSISTS OF:

PAGE

1	6S6845	WINDSHIELD WASHER GROUP.....	101
1	6S7697	WINDSHIELD WIPER GROUP.....	99B

6S7805 WINDSHIELD WASHER AND WIPER GROUP  
FOR USE WITH OPERATOR PROTECTIVE CAB ARRANGEMENT  
Only separate parts serviced. AN ATTACHMENT

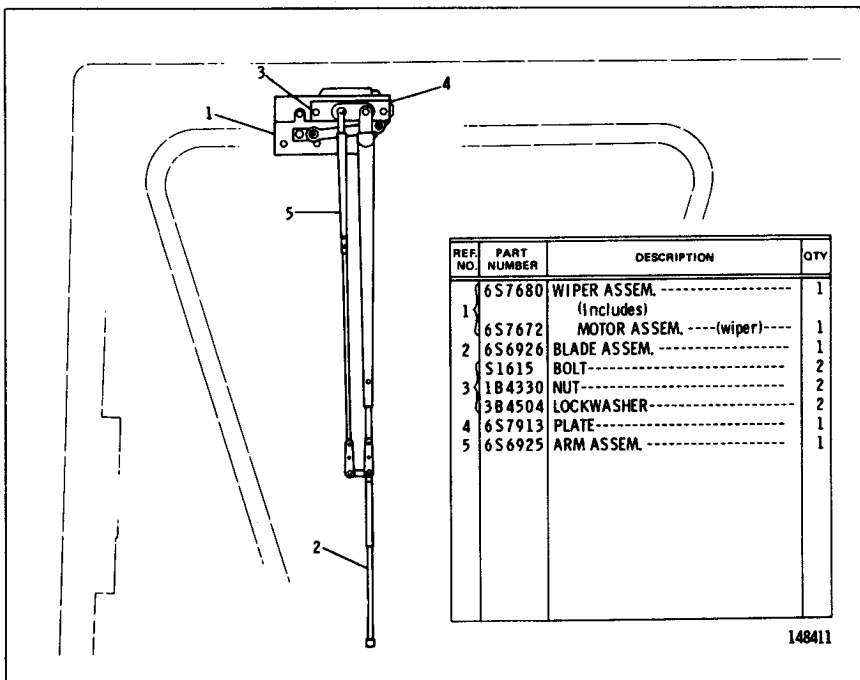

6S7697 WINDSHIELD WIPER GROUP—Type 2  
Part of 6S8475 and 6S8476 Cab Arrangements and 6S7805 Windshield  
Washer and Wiper Group listed on Pages 89B, 90A, 90B and 100

**6S6845 WINDSHIELD WASHER GROUP**  
 Part of 6S8475 and 6S8476 Cab Arrangements & 6S7805 Windshield Washer  
 & Wiper Group on Pages 89B, 90A, 90B, 90B-1 & 100

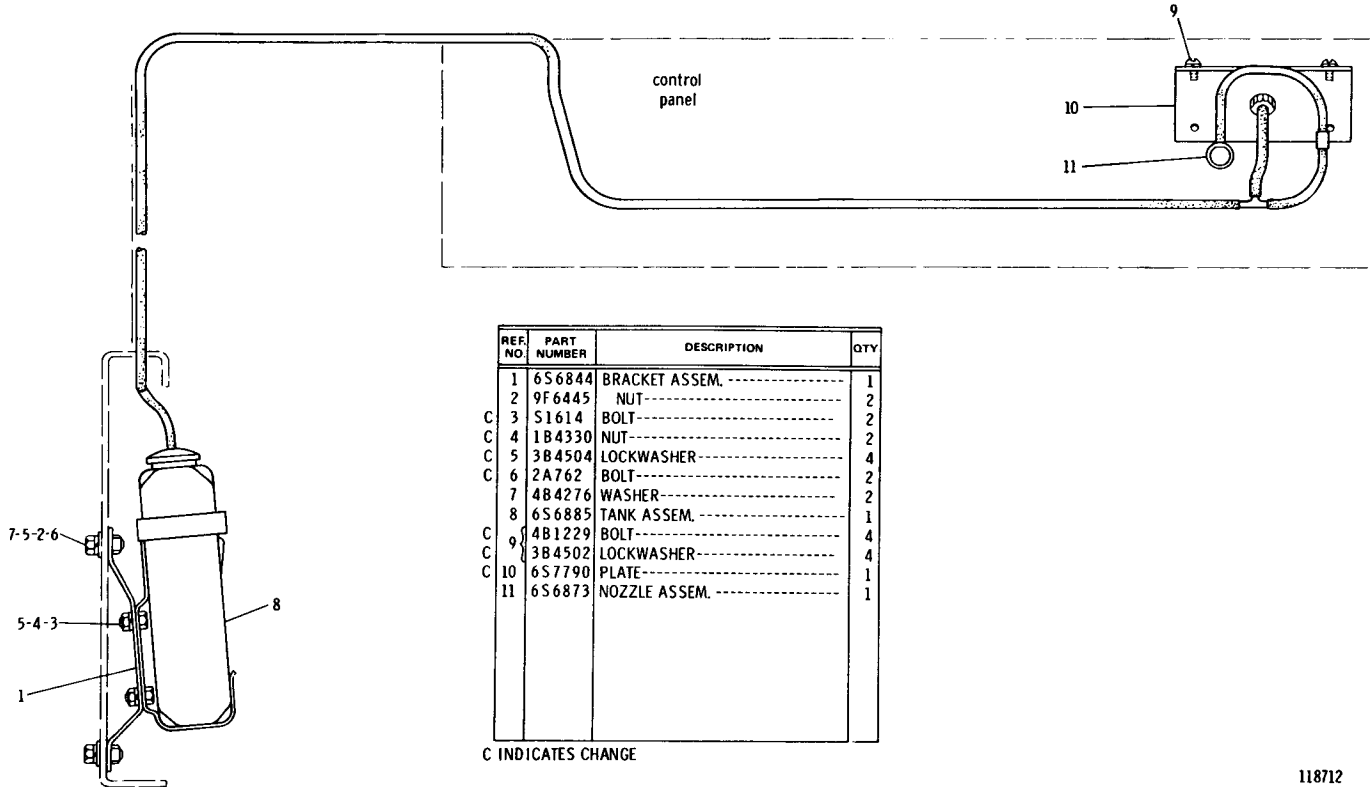

REF. NO.	PART NUMBER	DESCRIPTION	QTY
1	6S6844	BRACKET ASSEM. -----	1
2	9F6445	NUT-----	2
C 3	S1614	BOLT-----	2
C 4	1B4330	NUT-----	2
C 5	3B4504	LOCKWASHER-----	4
C 6	2A762	BOLT-----	2
7	4B4276	WASHER-----	2
8	6S6885	TANK ASSEM. -----	1
C 9	4B1229	BOLT-----	4
C 7	3B4502	LOCKWASHER-----	4
C 10	6S7790	PLATE-----	1
11	6S6873	NOZZLE ASSEM. -----	1

C INDICATES CHANGE



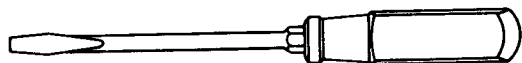

1F1157 SCREWDRIVER

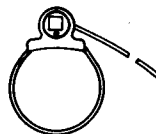

2P825D STRAP WRENCH ASSEM.

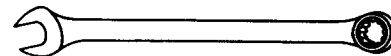

- 8H8508 WRENCH (9/16 in. Opening)
- 8H8505 WRENCH (3/8 in. Opening)
- 8H8511 WRENCH (3/4 in. Opening)

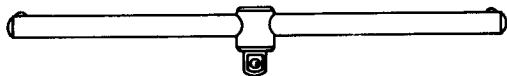

5S9566 WRENCH



- 8H8549 SOCKET (9/16 in. Opening)
- 8H8556 SOCKET (1 in. Opening)

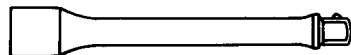

5S9567 EXTENSION

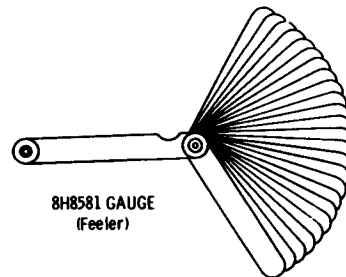

8H8581 GAUGE  
(Feeler)

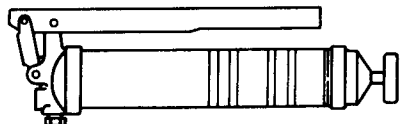

8F9866 GREASE GUN (Lever)  
(Separate Illustration)



5F4764 PRY BAR

116872

3P2244 HAND TOOL GROUP  
AN ATTACHMENT

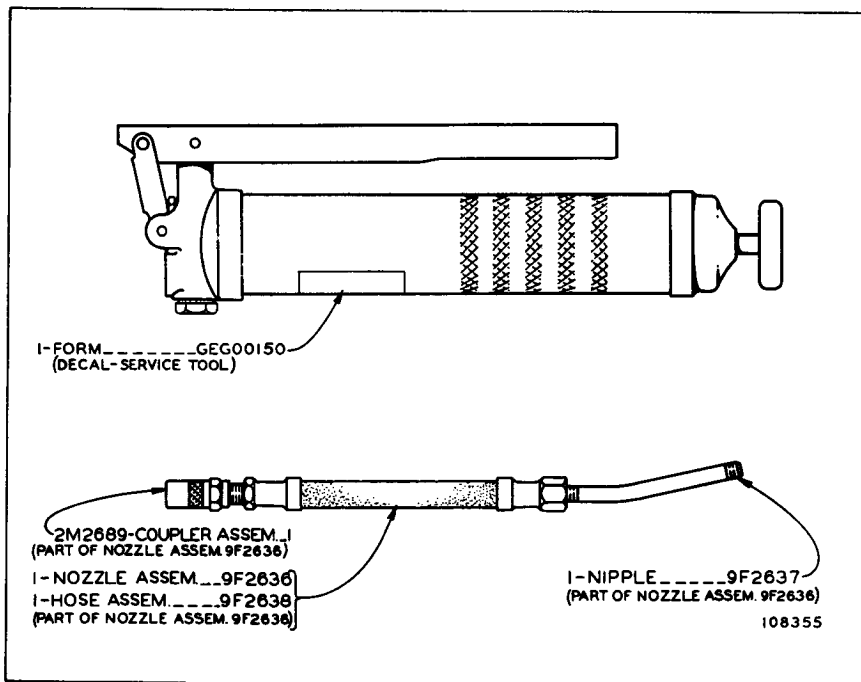

**8F9866 GREASE GUN**  
 Part of 3P2244 Hand Tool Group  
**AN ATTACHMENT**

## CATERPILLAR D3 TRACTOR

QUANTITY USED	PART NUMBER	DESCRIPTION
1	5A3016	PLATE--TRACTOR NUMBER ON TOP OF BEVEL GEAR CASE UNDER SEAT
1	5P215	PLATE--SERIAL NUMBER (MASTER) ON OUTSIDE OF R.H. PLATE OF FIREWALL ASSEMBLY
4	7B3028	DRIVE SCREW
1	2P9080	FILM--LUBRICATION ON L.H. SIDE OF OPERATOR STATION ON FRONT COVER OF FUEL TANK
1	5P5607	FILM--WARNING--DIRECT ELECTRIC STARTING ON DASH
1	3P587	TRANSFER GROUP CONSISTS OF:
2	.....	FILM--D3 ON SIDE OF HYDRAULIC TANK AND FUEL TANK
1	2P7972	FILM--WARNING ON DASH
1	5P4910	FILM--CAUTION BELOW HEAT START SWITCH ON DASH
1	1S8331	FILM--FAN WARNING ON HOOD DOOR
2	8S3922	FILM--CORPORATE SYMBOL ON SIDE OF HYDRAULIC TANK AND FUEL TANK
2	2P931	TRANSFER--CAT ON EACH SIDE OF DASH
1	2P9744	TRANSFER--CATERPILLAR ON FRONT OF RADIATOR GUARD
1	9S774	TRANSFER--CATERPILLAR ON BACK OF FUEL TANK

NAME PLATES &amp; TRANSFERS

## RELATED REPAIR ITEMS

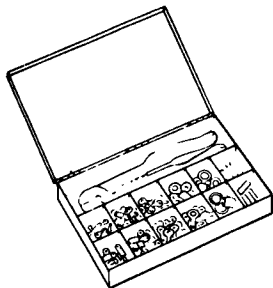

### IP2305 ELECTRIC TERMINAL KIT

(Insulated)  
(Includes terminals, wire joints  
and crimping tool)

### 9S3138 SEAL KIT

(Includes 28 metal - backed seals)

Qty.	Nominal Size	Part No.
2	1/2 inch (1, 27 cm)	511583
6	3/4 inch (1, 905 cm)	613575
6	1 inch (2, 54 cm)	613600
6	1 1/4 inch (3, 175 cm)	613625
4	1 1/2 inch (3, 81 cm)	613650
4	2 inches (5, 08 cm)	613800

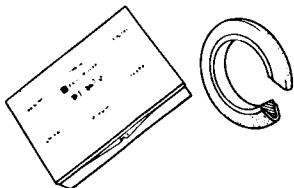

### 9S3135 SEAL KIT

(Includes 60 rubber O-ring seals)

Qty.	Nominal Size	Part No.
10	1/2 inch (1, 27 cm)	4J5140
10	3/4 inch (1, 905 cm)	4J5267
10	1 inch (2, 54 cm)	4J0520
10	1 1/4 inch (3, 175 cm)	4J0522
10	1 1/2 inch (3, 81 cm)	4J0524
10	2 inches (5, 08 cm)	4J0527

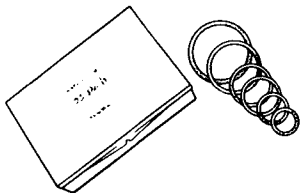

### THREADED INSERTS KITS

Master (Includes inserts and tools)

Coarse	Fine	Size
9S3700	9S3500	Assorted

Repair (Includes inserts and tools)

9S3510	9S3509	#10
9S3512	9S3511	1/4
9S3514	9S3513	5/16
9S3618	9S3515	3/8
9S3620	9S3619	7/16
9S3622	9S3621	1/2
9S3624	9S3623	9/16
9S3626	9S3625	5/8
9S3628	9S3627	3/4
9S3630	9S3629	7/8
9S3632	9S3631	1
9S3633		1 1/8
9S3635		1 1/4
9S3637		1 1/2

Refill (Includes inserts)

9S3674	9S3673	#10
9S3649	9S3639	1/4
9S3650	9S3640	5/16
9S3651	9S3641	3/8
9S3652	9S3642	7/16
9S3653	9S3643	1/2
9S3654	9S3644	9/16
9S3655	9S3645	5/8
9S3656	9S3646	3/4
9S3657	9S3647	7/8
9S3658	9S3648	1
9S3675		1 1/8
9S3677		1 1/4
9S3679		1 1/2

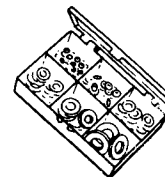
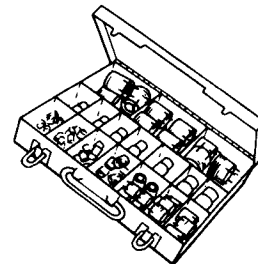

### HARDWARE ASSORTMENT KITS

8S7198 Course Thread Hex Nut  
8S7197 Fine Thread Hex Nut  
8S7196 Lockwasher Assortment  
8S7195 Flatwasher Assortment  
8S7193 Woodruff Key Assortment



GASKET CEMENT  
5H2471 8 oz. (227 g)

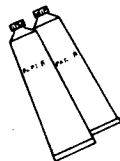

EPOXY CEMENT  
5M2941 2 - 2 oz. (57g) Tube

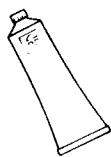

BEARING LUBRICANT  
253230 14 1/2 oz. (411 g)

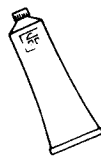

GASKET SEALER  
4H5363 11 oz. (312 g)  
(fast drying-hard setting)  
8H5137 11 oz. (312 g)  
(non-hardening)

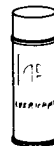

ANTI-SEIZURE COMPOUND  
459416 16 oz. (454 g) Aerosol  
9M3710 16 oz. (454 g) Paste



GLASS OR PLASTIC CEMENT  
3S1831 1 pint (0.473 L)



LIQUID GASKET  
7M7260 8 oz. (227 g)



SEALING COMPOUND  
5S1454 1 pint (0.473 L)



GREASE - SILICONE  
4L7464 8 oz. (227 g)

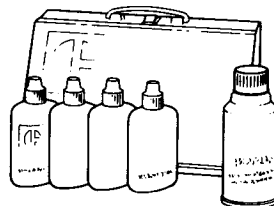

9S3262 SEALANT REPAIR KIT

contains:

Bearing Mount	7M7456	1 2/3 fl. oz. (50 cc)
Thread Lock	9S3263	1 2/3 fl. oz. (50 cc)
Pipe Sealant	9S3264	1 2/3 fl. oz. (50 cc)
Retaining Compound	9S3265	1 2/3 fl. oz. (50 cc)
Quick Cure Primer	8M8060	6 oz. (170 g) Aerosol



SILICONE FLUID  
8M553 145 cc.  
9M5165 150 cc.



GREASE GUN CARTRIDGE  
1P808 14 1/2 oz. (411 gms)

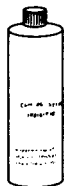

COOLING SYSTEM INHIBITOR  
3P2043 1 pint (0.473 L)  
P0001 1 case of 12  
3P2044 1 quart (0.946 L)  
P0002 1 case of 12



CHAIN & CABLE LUBRICANT  
9S6106 16 oz. (454 g) Aerosol  
2P2737 Case of 12

BELT DRESSING

9S6107 16 oz. (454 g) Aerosol  
2P2738 Case of 12

ELECTRO-INSULATION SPRAY

9S6108 16 oz. (454 g) Aerosol  
2P2739 Case of 12

PENETRATING OIL

9S6109 16 oz. (454 g) Aerosol  
2P2740 Case of 12

BATTERY SAVER & CLEANER

9S6110 16 oz. (454 g) Aerosol  
2P2741 Case of 12

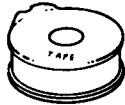

### ELECTRICAL TAPE

1P810 (plastic) 2 3/4" (20mm) width  
66 ft. (20m) length  
9B4287 (cloth) 3 1/4" (20mm) width  
30 ft. (9M) length  
(Plastic tape comes in dispenser.  
Cloth tape does not.)



### BUTTON PLUGS

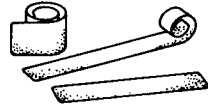

### 9S8703 ANTI-SKID TREADS

(May be ordered by foot lengths up to  
60 feet (18,30m), width 4" (100mm)



### MAGNETIC DRAIN PLUGS



### 8S4627 CIRCUIT TESTER

(Maximum Capacity: 10 oms)

Hole Diameter		Part Number	Type	Thread Size-Threads Per Inch	Head	A		Part No.
Inches	mm				Inches	Inches	mm	
.219	5,6	4L0820	I	5/8 - 11	7/8 Hex	1 3/16	26,9	5K1555
.310	7,9	7L6479	I	5/8 - 18	7/8 Hex	3/4	19,1	2R166
.380	9,7	5L6688	I	7/8 - 14	1 1/8 Hex	1 3/16	30,2	3H4190
.438	11,1	4L0821	I	1 1/8 - 12	1 1/2 Hex	1 1/2	38,1	8M3837
.469	11,9	3D9871	I	1 1/8 - 12	1 1/2 Hex	1 7/8	47,8	2J1559
.484	12,3	8M3839	I	1 1/2 - 12	1 Hex	1 1/2	38,1	8M5576
.500	12,7	3D9872	I	1 1/2 - 12	1 7/8 Hex	1 7/8	47,8	2D8390
.625	15,9	2M4009	II	1/2 - 14	9/16 Sq.	1 1/8	28,5	2F3628
.687	17,5	6K2660	II	3/4	5/8 Sq.	1 1/4	31,8	2H3865
.750	19,0	5K3546	II	7/8 - 14	7/8 Hex	1 5/8	41,3	2R1491
.875	22,2	5H4871	II	1 Std. Pipe Thd.	13/16 Sq.	1 7/16	36,6	2H3864
1.000	25,4	2D3406	II	1 1/4 Std. Pipe Thd.	15/16 Sq.	1 11/16	42,9	2H3863
1.250	31,8	4S6336	II	1 1/4 Std. Pipe Thd.	15/16 Sq.	1 3/8	35,0	7H3664
1.375	34,9	4F8711	III	3/4 - 14 Pipe Thd., Fine	1/2 Sq.	1 3/16	30,2	5D1894
1.500	38,1	3L1979	III	1 - 11 1/2 Pipe Thd., Fine	1/2 Sq.	1 5/16	33,4	2K744
2.000	50,8	1L6377	III	1 1/4 - 11 1/2 Pipe Thd., Fine	3/4 Sq.	13/16	20,6	5S4017
2.250	57,2	7M3248	III	2 - 12	3/4 Sq.	1 11/16	42,9	8B6599
2.500	63,5	3L8852						
3.000	76,2	1L6366						

# SPECIFICATIONS

(SUBJECT TO CHANGE WITHOUT NOTICE)

Weight, shipping (approximate) ..... 10,300 Lbs.

## DIMENSIONS

Length (without Bulldozer) .....	9'
Height (without Stack) .....	6' 1"
Width (over Tracks) .....	6' 2"
Gauge (center to center tracks) .....	56"
Ground Clearance .....	13.6"
Drawbar Height .....	15.4"

## CAPACITIES

Cooling System .....	6.5 U.S. Gal.
Crankcase, Lubricating Oil .....	3 U.S. Gal.
Transmission, Lubricating Oil .....	4.5 U.S. Gal.
Bevel Gear .....	4 U.S. Gal.
Final Drive, Lubricating Oil, each side .....	2.5 U.S. Gal.
Fuel Tank .....	30 U.S. Gal.

## ATTACHMENTS

Additional equipment such as Crankcase Guards, Front Pull Hooks, Lighting System, Swinging Drawbar, Suction Fan, Seat Belt, Operator Protective Cab, Defrosting Fan, Windshield Washer and Wiper, etc., are available at extra cost. Consult your CATERPILLAR dealer.

## MACHINE SERIAL NUMBER PLATE LOCATION

Serial Number Plate is located on the R.H. side of the cylinder block, on the R.H. side of the firewall in the operator's compartment and on top of the bevel gear case under the seat.

# CARACTÉRISTIQUES

(PEUVENT ÊTRE MODIFIÉES SANS PRÉAVIS)

Poids (approx.), en ordre d'expédition ..... 4670 kg

## DIMENSIONS

Longueur (sans bulldozer) .....	2 740 mm
Hauteur (sans tuyau d'échappement) .....	1 850 mm
Largeur (à l'extérieur des chaînes) .....	1 880 mm
Voie (entre centres des chaînes) .....	1 420 mm
Garde au sol .....	350 mm
Hauteur de la barre d'attelage .....	390 mm

## CONTENANCES

Circuit de refroidissement .....	25 litres
Circuit de graissage :	
Carter moteur .....	11 litres
Transmission .....	17 litres
Couple conique .....	15 litres
Réducteurs latéraux (chaque) .....	9 litres
Réservoir de carburant .....	114 litres

## ACCESSOIRES

Les équipements supplémentaires tels que protège-carter, crochet avant, éclairage, barre d'attelage pivotante, ventilateur aspirant, ceinture de sécurité, cabine de protection, dégivreur, essuie-glace et lave-glace, etc., sont facultatifs et facturés en sus. Consulter le concessionnaire Caterpillar.

## MARQUAGE DU NUMÉRO DE SÉRIE

Les plaques portant le numéro de série sont situées sur le côté droit du bloc-cylindres, sur le côté droit du cloison pare-feu du poste de conduite et au sommet du carter de couple conique, sous le siège.



# ESPECIFICACIONES

(SUJETAS A CAMBIO SIN PREVIO AVISO)

Peso de embarque aproximado ..... 4670 kg

## DIMENSIONES

Largo (sin hoja topadora) ..... 2740 mm  
 Alto (sin tubo de escape) ..... 1850 mm  
 Ancho (sobre los carriles) ..... 1880 mm  
 Trocha (de centro a centro de los carriles) ..... 1420 mm  
 Despeje sobre el suelo ..... 350 mm  
 Alto de barra de tiro ..... 390 mm

## CAPACIDADES

Sistema de enfriamiento ..... 25 litros  
 Aceite lubricante del cárter ..... 11 litros  
 Aceite lubricante de la transmisión ..... 17 litros  
 Corona ..... 15 litros  
 Aceite lubricante de los mandos finales, a cada lado ..... 9 litros  
 Tanque de combustible ..... 114 litros

## ACCESORIOS

Equipo adicional como protectores del cárter, ganchos delanteros, sistema de luces, barra de tiro giratoria, ventilador de succión, cinturón de seguridad, cabina protectora del operador, ventilador descongelador, limpiador y lavador del parabrisas, se suministran a precio adicional. Consulte al distribuidor de Caterpillar.

## UBICACION DE LAS PLACAS CON EL NUMERO DE SERIE DE LA MAQUINA

Las placas con el número de serie de la máquina están colocadas al lado derecho del bloque del motor, a la derecha de la plancha de separación del motor, en el compartimiento del operador, y en la caja de la corona, bajo el asiento.

# ESPECIFICAÇÕES

(SUJEITAS A ALTERAÇÕES SEM AVISO PRÉVIO)

Peso de embarque (aproximado) ..... 4670 kg

## DIMENSÕES

Comprimento (sem lâmina) ..... 2740 mm  
 Altura (sem tubo de descarga) ..... 1850 mm  
 Largura (por fora das esteiras) ..... 1880 mm  
 Bitola (centro a centro das esteiras) ..... 1420 mm  
 Altura livre por baixo ..... 350 mm  
 Altura da barra de tração ..... 390 mm

## QUANTIDADES CONTIDAS

Sistema de arrefecimento ..... 25 litros  
 Cártter do motor ..... 11 litros  
 Caixa de mudanças ..... 17 litros  
 Caixa da coroa ..... 15 litros  
 Comando final (cada) ..... 9 litros  
 Tanque de combustível ..... 114 litros

## ACESSÓRIOS

Existem disponíveis equipamentos extras tais como protetor do cártter, gancho dianteiro, sistema de iluminação, barra de tração oscilante, ventilador succionador, cinto de segurança, cabine de segurança, degelador, lavador e limpador do pára-brisa, etc. Consulte o seu revendedor Caterpillar.

## SITUAÇÃO DO NÚMERO DE SÉRIE

Existem placas com o número de série no lado direito do bloco do motor, no lado direito do painel traseiro do motor no compartimento do operador e em cima da caixa da coroa, sob o assento.

# TECHNISCHE DATEN

(UNVERBINDLICH, ÄNDERUNGEN VORBEHALTEN)

Versandgewicht, etwa ..... 4670 kg

## ABMESSUNGEN

Länge (ohne Planierschild) .....	2 740 mm
Höhe (ohne Auspuff) .....	1 850 mm
Breite (Außenkante Laufkette) .....	1 880 mm
Spurweite .....	1 420 mm
Bodenfreiheit .....	350 mm
Zugbalkenhöhe .....	390 mm

## FÜLLMENGEN

Kühlsystem .....	25 l
Schmierung:	
Kurbelgehäuse .....	11 l
Getriebe .....	17 l
Tellerrad .....	15 l
Seitenantrieb, je .....	9 l
Kraftstofftank .....	114 l

## ZUBEHÖR

Zusätzliche Ausrüstung wie Panzerwannen, Frontzughaken, Beleuchtungsanlage, Schwenkzugbalken, Sauglüfter, Sitzgurte, Fahrerhaus, Entfrostergebläse, Scheibenwischer und -waschanlage usw. sind gegen Aufpreis erhältlich. Fragen Sie Ihren Caterpillar-Händler.

## LAGE DER SERIENNUMMERNSCHILDER

Seriennummernschilder befinden sich rechts am Motorblock, rechts an der Feuerwand im Fahrerstand und an der Oberseite des Tellerradgehäuses, unter dem Fahrersitz.