

# ATTACHMENTS

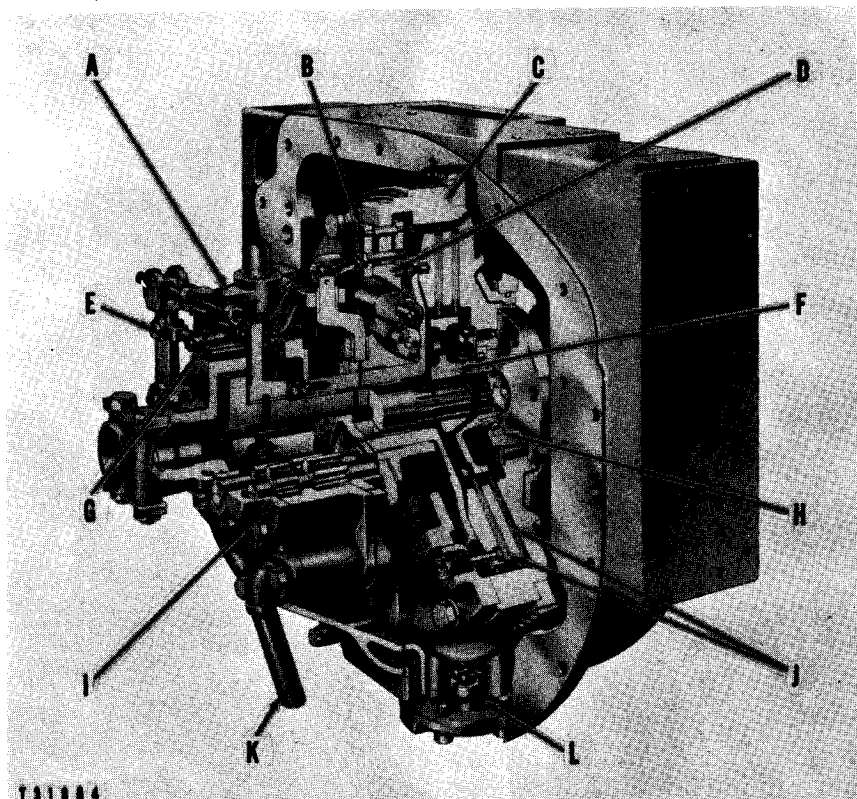

**CUTAWAY OF FLYWHEEL OIL CLUTCH**

**A-Clutch lever. B-Lock assembly. C-Flywheel. D-Inner adjusting ring. E-Brake link. F-Hub. G-Brake assembly. H-Race. I-Oil pump. J-Plates. K-Suction line. L-Screen assembly.**

## Flywheel Clutch

(Oil Type)

### OPERATION

The oil clutch transmits the engine torque to the transmission from the flywheel through the clutch plates (13), (17), (6) and (7); then through hub assembly (8), clutch shaft (9) and coupling assembly (1).

The driving plates (13) and (17) have external teeth which mate with internal teeth in the flywheel.

The driven plates (6) and (7) have internal teeth which mate with external teeth on the hub assembly (8) which is splined to the clutch shaft (9).

The flanged end of the clutch shaft is secured to the transmission

upper shaft by the coupling assembly (1). The flanged end of the clutch shaft is supported by the bearing (2) located in the clutch support assembly (14). The forward end of the clutch shaft is piloted in the splined bore of the hub (8) which in turn is piloted in the flywheel by the bearing (10).

When engaging the clutch, pressure is applied to the clutch engaging lever, moving the yoke and collar (3) forward against the collar assembly (4).

The roller (11) on the collar assembly (4) forces the roller assembly (12) on the adjusting ring (15) against the plate assembly (5).

The plate assembly (5) forces the rear driving plate (17) against the driven plate (6) which in turn is forced against the driving plate (13). This plate forces the driven plate (7) against the flywheel.

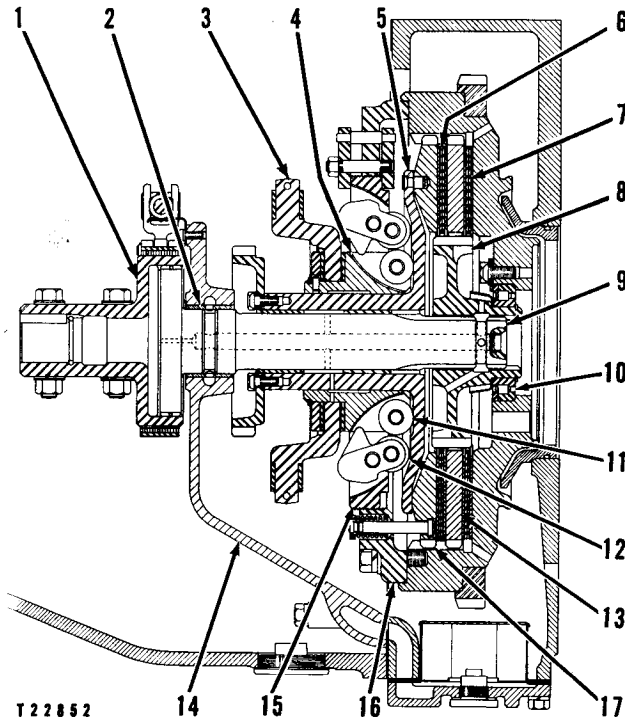

#### FLYWHEEL CLUTCH OPERATION

1-Coupling assembly. 2-Bearing. 3-Collar. 4-Collar assembly. 5-Plate assembly. 6-Driven plate. 7-Driven plate. 8-Hub assembly. 9-Clutch shaft. 10-Bearing. 11-Roller. 12-Roller assembly. 13-Driving plate. 14-Clutch support assembly. 15-Adjusting ring. 16-Bracket. 17-Driving plate.

The flywheel and driving plates (13) and (17) transmit the torque to the driven plates (6) and (7).

The driven plates rotate the hub assembly (8) which turns the clutch

shaft (9) transmitting the torque to the transmission through the coupling assembly (1).

### LUBRICATION

A two-section gear-type pump is mounted on the clutch support assembly (13). One section picks oil up through the screen (18) from the sump of the flywheel housing and discharges it into the rear portion of the clutch compartment. The other section delivers oil from the clutch compartment to the clutch.

The oil pump is driven by the driving plate (4) through the dowel (3), plate (17) and gear (11).

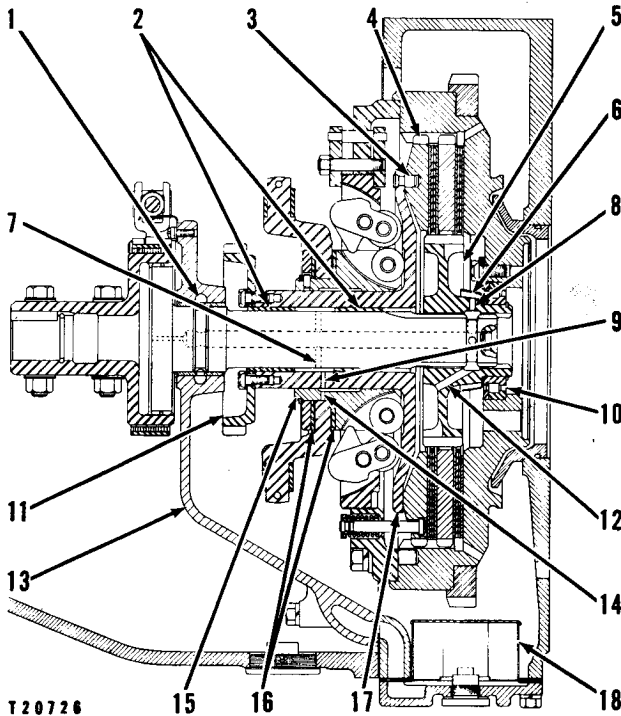

**FLYWHEEL CLUTCH LUBRICATION**

1-Passage. 2-Bushings. 3-Dowel. 4-Driving plate. 5-Hub assembly. 6-Deflector. 7-Passage. 8-Passage. 9-Passage. 10-Bearing. 11-Gear. 12-Passage. 13-Clutch support assembly. 14-Passage. 15-Collar assembly. 16-Washers. 17-Plate. 18-Screen.

The oil is pumped through the passage (1) in the clutch support assembly (13) into the center of the clutch shaft. Some oil goes through the flange at the rear of the shaft to lubricate the splines on the shaft and coupling.

Oil also goes through the passage (7) to the bushings (2) through the

passage (9) to the collar assembly (15) and through the passage (14) to the washers (16).

Oil flows through the passages (8) and (12) in the hub (5) to the clutch plates. The deflector (6) directs oil to the hub and plates.

Some of the oil travels along the splines between the clutch shaft and hub and lubricates the bearing (10).

The balance of the clutch is splash lubricated. The plates are cooled by oil thrown centrifugally from the hub assembly (5). The oil passes through the holes in the flywheel and drains back to the sump where it is picked up by the pump through the screen (18).

### FLYWHEEL CLUTCH REMOVAL

Raise the rear of the tractor until the engine is tilted to the front. Both driven and one driving plate will then remain in position on the hub and eliminate possible damage to them when the clutch cover is removed.

#### Floor Plate and Dash Removal

1. Remove the diesel engine air cleaner (3).
2. Remove the floor plates (8).

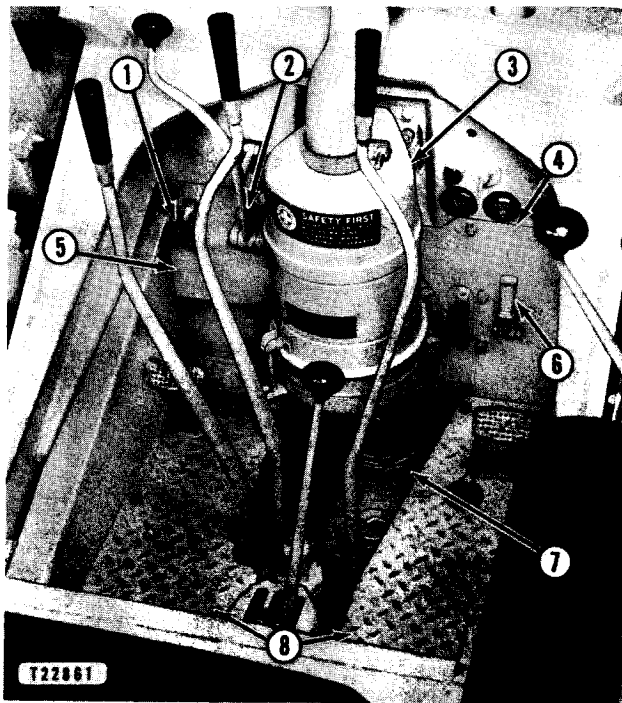

#### FLOOR PLATE AND DASH REMOVAL

- 1-Starter pinion control knob. 2-Governor control lever. 3-Air cleaner. 4-Dash plate (right). 5-Dash plate (left). 6-Compression release lever. 7-Starting engine flywheel. 8-Floor plates.

3. Remove the starter pinion control knob (1) and disconnect the governor control lever (2) from the dash.
4. Remove the capscrews securing the left dash plate (5) and remove the plate.
5. Remove the compression release lever (6) and key.
6. Remove the capscrews securing the right dash plate (4) and remove the plate.
7. Loosen the electric starter and remove the starter drive belt. Loosen the governor and remove the governor drive belt.
8. Flatten the lock and remove the nut securing the starting engine flywheel (7) to the crankshaft. Remove the flywheel and replace the nut to protect the threads.

### Clutch Cover Removal

1. Remove the plugs and drain the oil from the flywheel housing and clutch compartment, and remove the oil level gauge (5).
2. Remove the lever, linkage, key and washer from the clutch control shaft (3).
3. Disconnect the left dash support bracket (1).

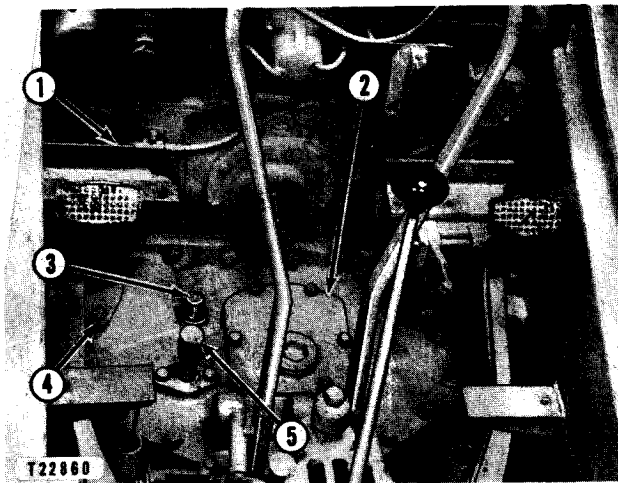

#### PREPARING TO REMOVE CLUTCH COVER

- 1-Dash support bracket. 2-Inspection cover. 3-Clutch control shaft. 4-Starter pinion inspection cover.  
5-Oil level gauge.

4. Remove the starter pinion inspection cover (4) for access to clutch cover capscrews.

5. Remove the inspection cover (2) and loosen the capscrew (7) securing the control shaft lever (6) to the control shaft (3).
6. Remove the capscrews that secure the clutch cover to the flywheel clutch compartment.

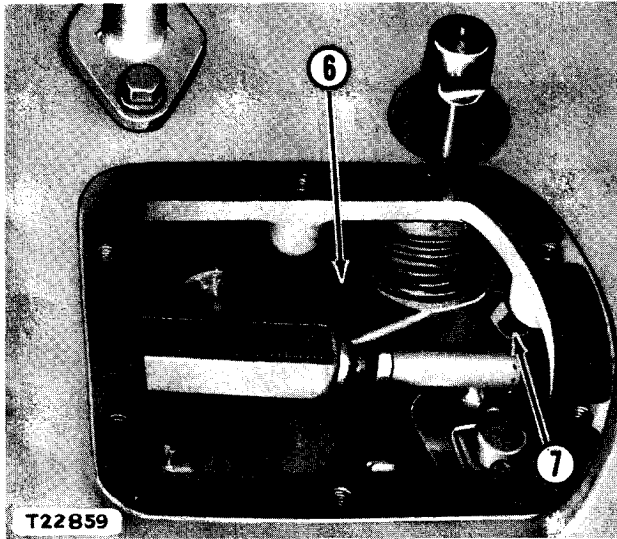

**INSPECTION COVER REMOVED**  
6—Control shaft lever. 7—Capscrew.

7. Drive the control shaft (3) down into the clutch support assembly until it is free from the clutch cover. This dislodges the plug under the shaft in the support assembly. Be sure to replace this plug at final installation.
8. Remove the clutch cover.

### **Removing Flywheel Clutch Mechanism**

1. Remove the right dash support bracket and brake lock assembly.
2. Remove the spring from the control shaft.
3. Disconnect the interlock linkage (9) from the lever (5).
4. Remove the cotter pin from the shaft (2) and remove the capscrews securing the bracket (3) and the clamp (6) to the clutch support assembly (4) then remove the band assembly (8).
5. Flatten the locks and remove the bolts and nuts securing the coupling assembly (7). Remove the coupling assembly and ring from the clutch shaft coupling gear.
6. Remove the breather pipe (1).

7. Remove the capscrews securing the tube assembly (11) to the oil pump (10) and remove the tube assembly.

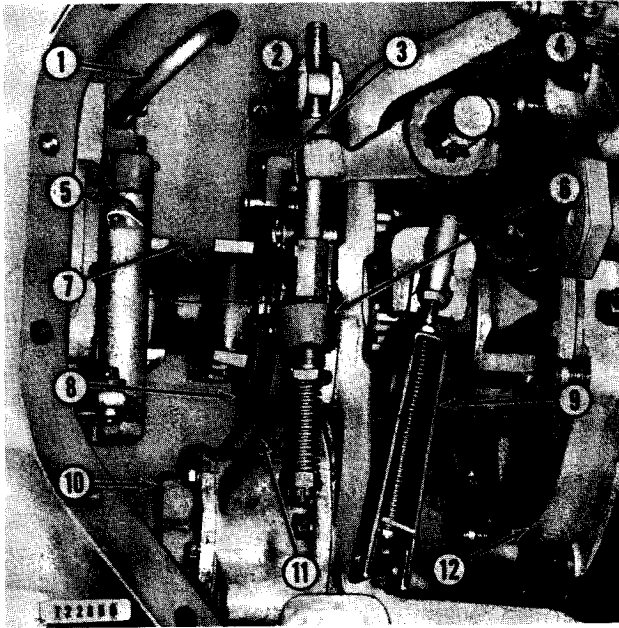

#### FLYWHEEL CLUTCH REMOVAL

- 1-Breather pipe. 2-Shaft. 3-Bracket. 4-Clutch support assembly. 5-Lever. 6-Clamp.  
7-Coupling assembly. 8-Band assembly. 9-Interlock linkage. 10-Oil pump.  
11-Tube assembly. 12-Bracket.

8. Remove the oil pump (10) from the clutch support assembly (4).

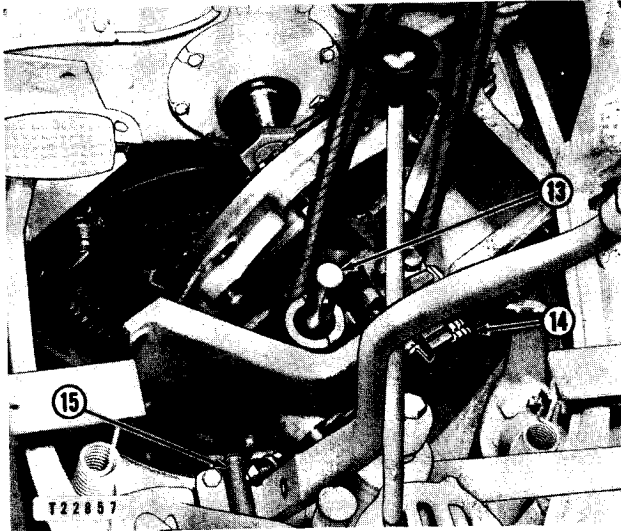

#### REMOVING FLYWHEEL CLUTCH MECHANISM

- 13-Control shaft. 14-Clutch shaft. 15-Linkage.

9. Remove the capscrews securing the bracket (12) to the flywheel. Rotate the clutch mechanism as required for access to all capscrews.
10. Disconnect the linkage (15) from each steering clutch control lever as shown.
11. Attach a suitable hoist and sling to the clutch mechanism and remove the capscrews securing the clutch support assembly (4) to the flywheel housing.
12. Engage the starting engine pinion.
13. Remove the clutch shaft (14) to the rear until the splines on its forward end are disengaged from the splines in the hub.
14. Raise the control shaft (13) slightly and, at the same time, move the clutch support assembly to the rear to clear the dowels in the flywheel housing.
15. Slowly raise the clutch mechanism out of the clutch compartment.

### Removing Clutch Plates and Hub Assembly

1. Remove the driven plates (3) and the driving plate (4) from the flywheel (2) and the hub assembly (1).

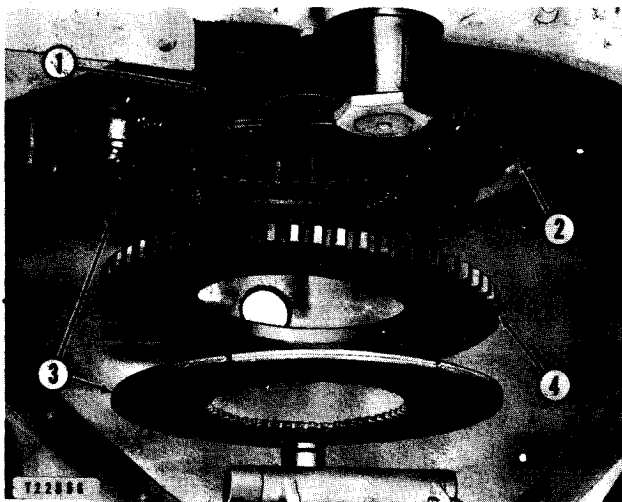

#### REMOVING CLUTCH PLATES AND HUB ASSEMBLY

1-Hub assembly. 2-Flywheel. 3-Driven plates.  
4-Driving plate.

2. Remove the capscrews through the holes in the hub assembly (1) and remove the hub from the flywheel.
3. The bearing outer race (5) can be removed from the flywheel with the 8B7554 Puller and the 8B7561 Step Plate as shown.



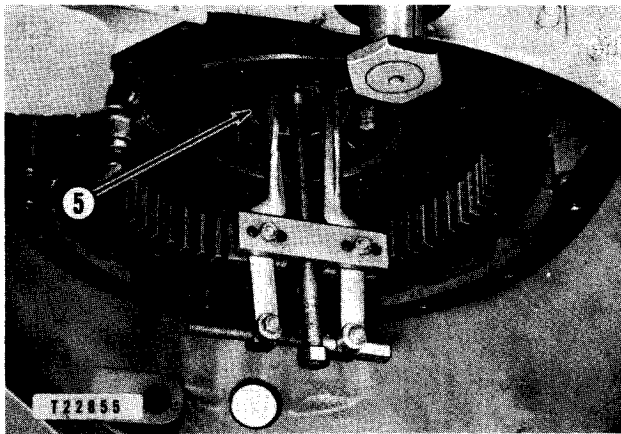

**BEARING OUTER RACE REMOVAL**  
5-Bearing outer race.

### OIL PUMP DISASSEMBLY AND ASSEMBLY

1. Flatten the locks and remove the capscrews securing the rear cover (3) to the pump body (2).
2. Remove the rear cover (3) and replace the bushing (4) if it is scored or worn excessively.
3. Remove the rear idler gear (1).
4. Remove the rear drive gear (5) and the key from the oil pump drive shaft (6).

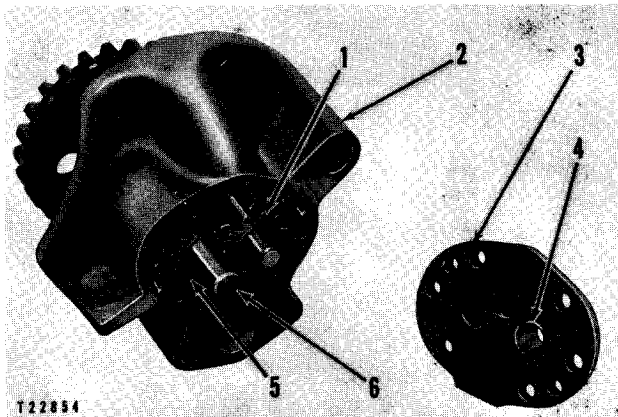

**REAR COVER REMOVED**  
1-Rear idler gear. 2-Pump body. 3-Rear cover. 4-Bushing.  
5-Rear drive gear. 6-Oil pump drive shaft.

5. Flatten the locks and remove the capscrews securing the front cover (7) to the pump body (2).

6. Remove the ring located on the oil pump drive shaft (6) in front of the oil pump drive gear (8).
7. Using an 8B7547 Puller and an 8B7560 Step Plate, as shown, remove the oil pump drive gear (8).

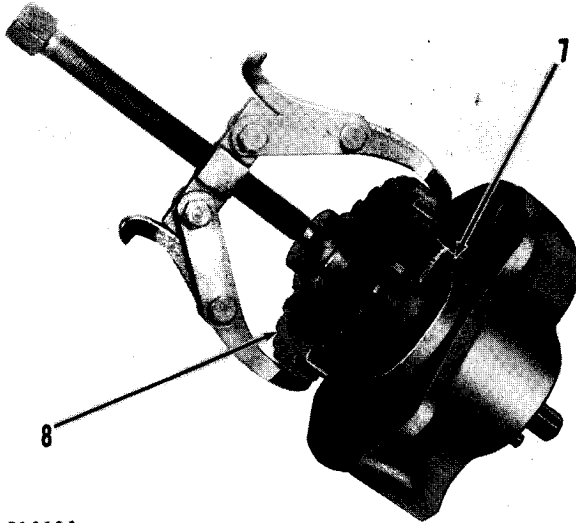

T22853

**OIL PUMP DRIVE GEAR REMOVAL**  
7-Front cover. 8-Oil pump drive gear.

8. Remove the key and the remaining ring from the oil pump drive shaft.

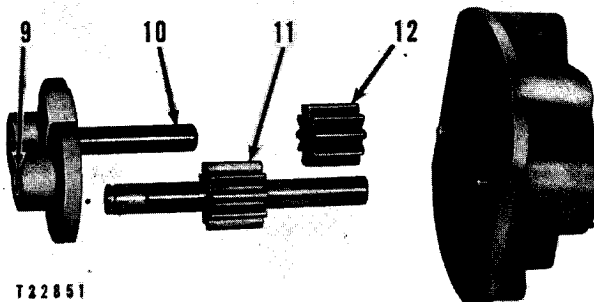

T22851

**FRONT COVER AND GEARS REMOVED**  
9-Bushing. 10-Idler gear shaft. 11-Front drive gear.  
12-Front idler gear.

9. Remove the front cover (7) and replace the bushing (9) if it is scored or worn excessively.

10. Remove the front drive gear (11) and oil pump drive shaft, being careful not to damage the bushing in the pump body. Replace the bushing if it is scored or worn excessively.
11. Remove the front idler gear (12).
12. Remove the rings from both sides of the front drive gear (11), press the gear off the oil pump drive shaft (6) and remove the key.
13. If the idler gear shaft (10) is worn excessively, press the shaft out of the front cover (7) and replace it with a new shaft.
14. Assemble in the reverse order of disassembly.

### CLUTCH MECHANISM DISASSEMBLY

Cleanliness is especially important while doing maintenance or reconditioning work on the oil clutch, since the presence of foreign material in the clutch will result in excessive wear.

#### Disassembly of the Hub Assembly

1. Remove the retainer ring (5) from the hub (3).
2. Remove the bearing (2) and ring (4) from the hub.
3. Remove the deflector (1) from the hub.

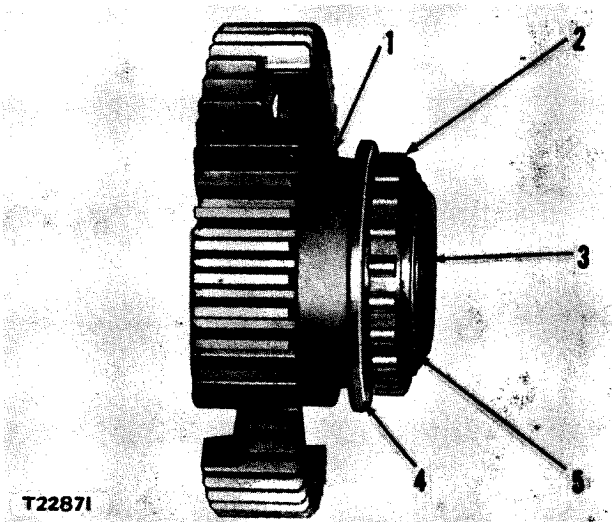

T22871

#### DISASSEMBLY OF THE HUB ASSEMBLY

1-Deflector. 2-Bearing. 3-Hub. 4-Ring.  
5-Retainer ring.

#### Removing the Pressure Plate Assembly and Collar Assembly

1. With the clutch mechanism in the position shown, lift the pressure

plate assembly (1) from the clutch support assembly (5) and clutch shaft (2).

#### NOTE

As the pressure plate assembly (1) is lifted, the yoke (3) will move off of the blocks (4).

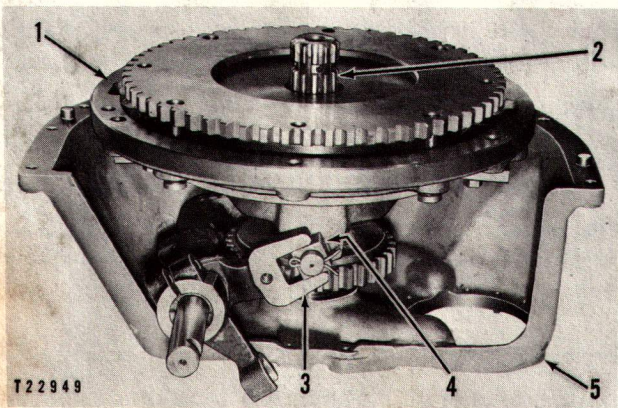

#### PRESSURE PLATE ASSEMBLY AND COLLAR ASSEMBLY REMOVAL

1-Pressure plate assembly. 2-Clutch shaft. 3-Yoke.  
4-Block. 5-Clutch support assembly.

#### Disassembling Collar Assembly

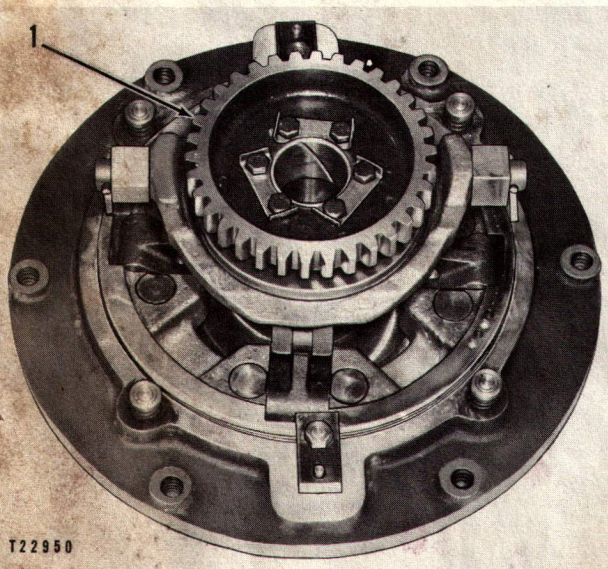

#### OIL PUMP DRIVE GEAR REMOVAL

1-Oil pump drive gear.



1. Flatten the locks and remove the capscrews securing the oil pump drive gear (1) to the hub of the plate assembly (3). Remove the oil pump drive gear (1).

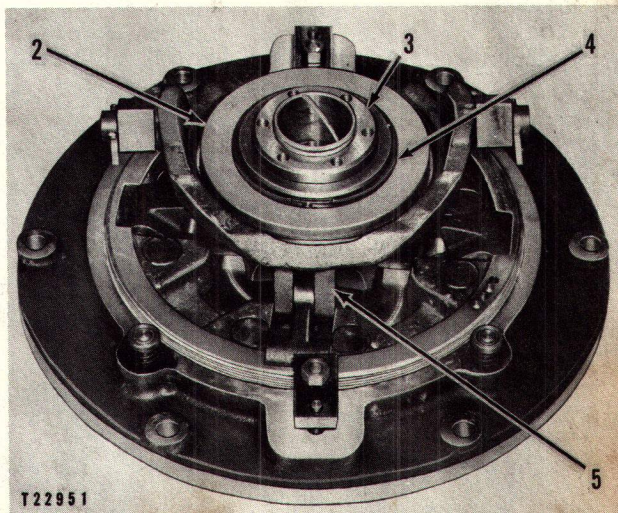

**PREPARING TO REMOVE COLLAR**

2-Retainer. 3-Plate assembly. 4-Snap ring.  
5-Collar assembly.

2. Remove the snap ring (4) and retainer (2) from the collar assembly (5).

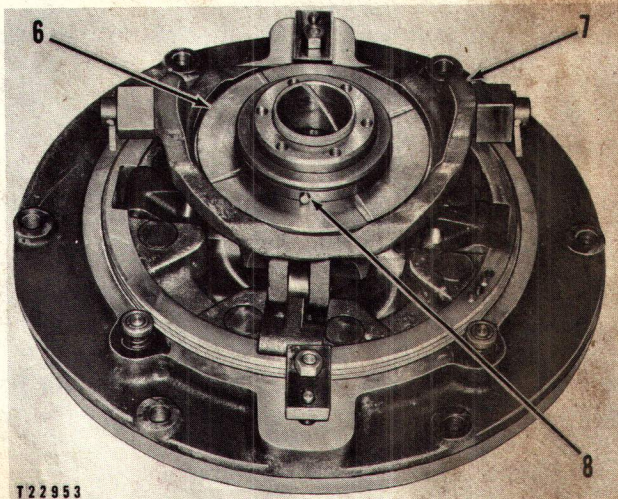

**COLLAR REMOVAL**

6-Washer. 7-Collar. 8-Pin.

3. Remove the pin (8), the washer (6), the collar (7) and the other washer located between the collar (7) and collar assembly (5).
4. Remove the cotter pins securing the blocks to the collar (7) and remove the blocks.
5. Remove the collar assembly (5) from the hub of the plate assembly (3).

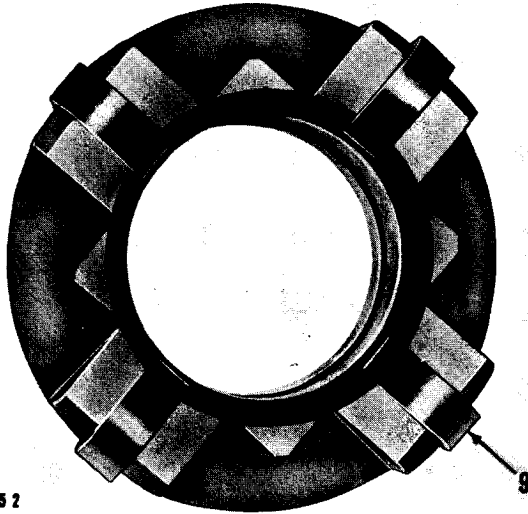

122952

**DISASSEMBLY OF COLLAR ASSEMBLY**  
9-Roller.

6. Press out the pins that secure the rollers (9) to the collar assembly (5).

#### **Removing Ring and Bracket from Plate Assembly**

1. Remove the nut and top plate from each adjusting ring lock assembly (3).
2. Compress the springs (6) and remove the locks (8) and the retainers (7). Remove the springs (6) from the studs (4).
3. Lift the bracket (1) and adjusting ring (5) off the plate assembly and pressure plate.
4. Remove the studs (4) from the pressure plate.
5. Press out the bushing (2) and the bushing located in the center of the hub of the plate assembly.



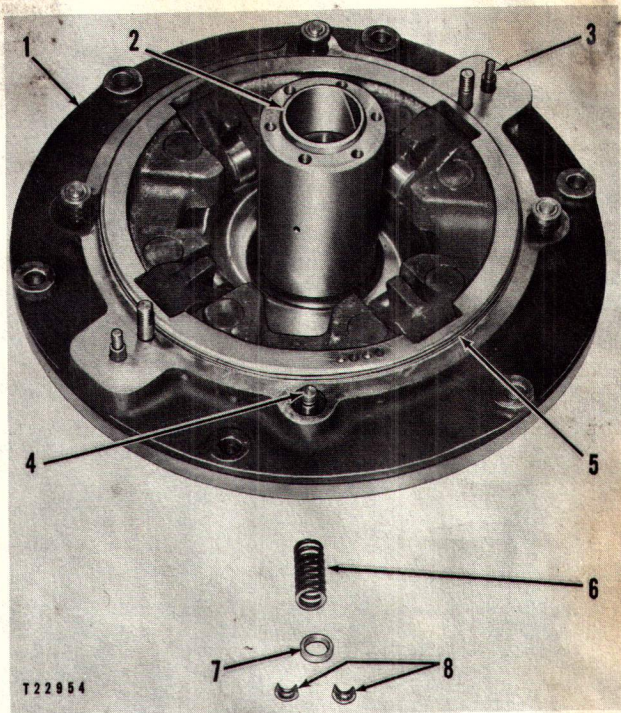

**DISCONNECTING PRESSURE PLATE FROM BRACKET**  
 1-Bracket. 2-Bushing. 3-Adjusting ring lock assembly.  
 4-Stud. 5-Adjusting ring. 6-Spring. 7-Retainer.  
 8-Locks.

### Link Assembly Removal and Disassembly

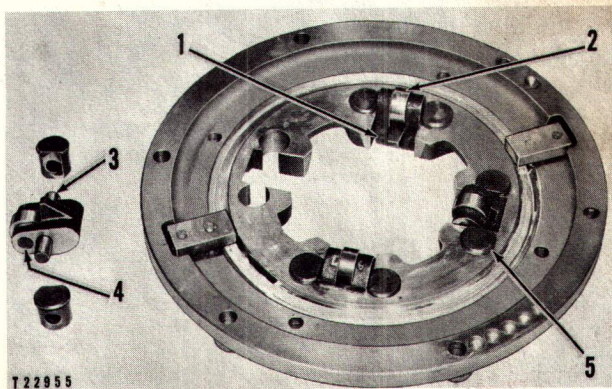

**LINK ASSEMBLY REMOVAL**  
 1-Link assembly. 2-Roller. 3-Pin. 4-Pin. 5-Bushing.

1. With the forward side of the adjusting ring and bracket up, remove the link assemblies (1) and bushings (5) from the adjusting ring.



2. Press out the pins (4) that secure the rollers (2) to the link assemblies (1). Remove the rollers.
3. Remove the adjusting ring lock assemblies.
4. Remove the adjusting ring from the bracket.

### Disassembling the Support Assembly

1. Remove the yoke (3), lever (5), and shaft (4) from the support assembly (1).
2. Remove the yoke (3) and the lever (5) from the shaft (4).
3. Remove the clutch shaft (6) from the support assembly.

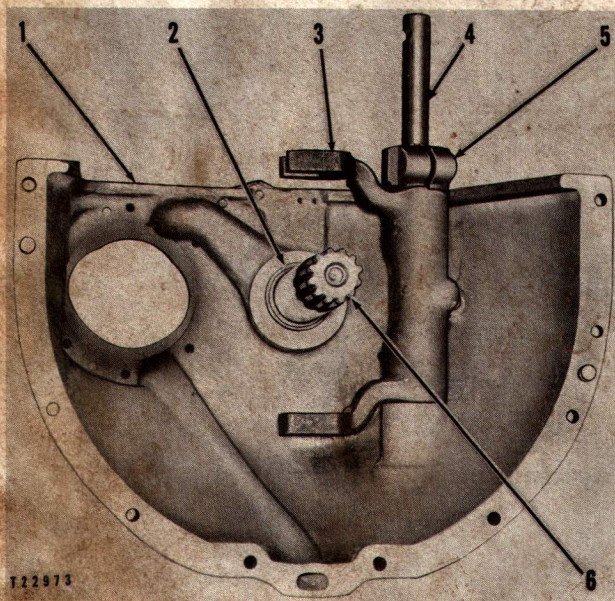

**DISASSEMBLY OF SUPPORT ASSEMBLY**  
 1-Support assembly. 2-Bushing. 3-Yoke. 4-Shaft.  
 5-Lever. 6-Clutch shaft.

4. Remove the bushing (2) from the support assembly.
5. Remove the bearing that supports the lower end of the shaft (4).

### Disassembling Brake Linkage

1. Disconnect the rod between the band assembly (11) and the lever assembly (1), and the bracket (8) from the band assembly (11) by removing the cotter pins and pins (10).
2. Remove the cotter pin securing the nut (5) and remove the nut (5) and spring (7) from the rod assembly (3).



3. Remove the guide (4) and clamp (9) from the rod assembly (3). Move the guide (4) from the clamp (9).
4. Remove the rod assembly (3) from the pin (2), and remove the pin (2) from the lever assembly (1).
5. Press the bushing (6) out of the lever assembly (1).

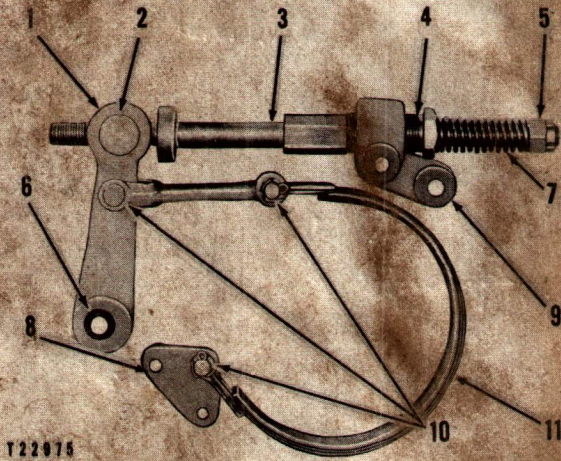

#### BRAKE LINKAGE DISASSEMBLY

- 1-Lever assembly. 2-Pin. 3-Rod assembly. 4-Guide. 5-Nut.  
6-Bushing. 7-Spring. 8-Bracket. 9-Clamp.  
10-Pins. 11-Band assembly.

#### CLUTCH MECHANISM ASSEMBLY

1. Assemble the brake linkage in the reverse order of disassembly.
2. Assemble the support assembly in the reverse order of disassembly.

#### CAUTION

Install the plug in the support assembly under the shaft.

3. Install the adjusting ring (15) and the adjusting ring lock assemblies (4) in the bracket (5) in the reverse order of disassembly.
4. Assemble the link assemblies (13) and install them in the adjusting ring (15) in the reverse order of disassembly.
5. When installing new bushings (18) in the plate assembly (16), the dimension (A) should be  $\frac{1}{4}$ " and the dimension (B) should be 1".
6. Assemble the pressure plate (17) and plate assembly (16) to the adjusting ring (15) and bracket (5) in the reverse order of disassembly being sure to seat the dowel (6) properly in the pressure plate (17).



the nuts and top plates on the adjusting ring lock assemblies be sure that the longer end of the plates rest on the adjusting ring.

8. Assemble the collar assembly (3) and install it over the hub of the plate assembly (16) in the reverse order of disassembly.

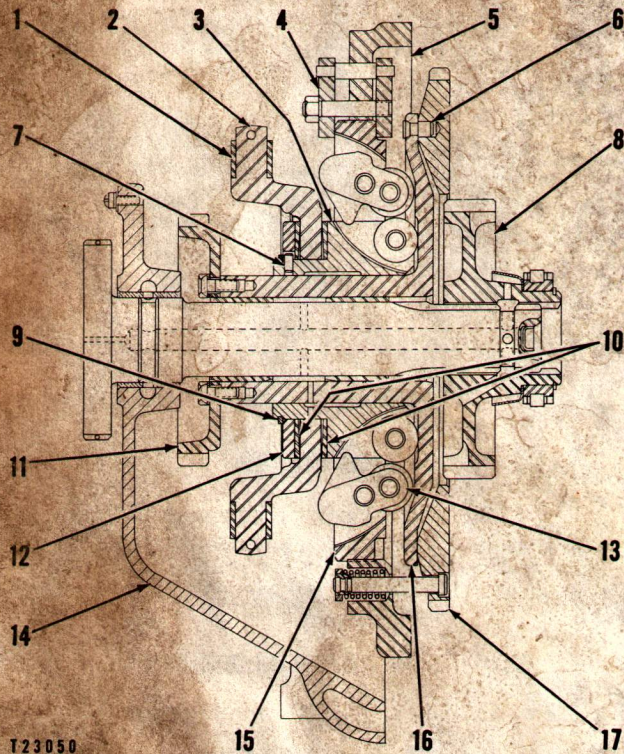

T23050

### CLUTCH CROSS-SECTION

1-Block. 2-Collar. 3-Collar assembly. 4-Adjusting ring lock assembly. 5-Bracket. 6-Dowel. 7-Dowel. 8-Hub. 9-Snap ring. 10-Washers. 11-Oil pump drive gear. 12-Retainer. 13-Link assemblies. 14-Clutch support assembly. 15-Adjusting ring. 16-Plate assembly. 17-Pressure plate.

9. Install the blocks (1) on the collar (2).
10. Assemble the washers (10), collar (2), dowel (7), retainer (12) and snap ring (9) on the collar assembly (3) in the reverse order of disassembly. The dowel (7) should extend  $9/64$ " beyond the outside diameter of the collar assembly.
11. Install the oil pump drive gear (11).
12. Replace the pressure plate assembly and collar assembly in the clutch support assembly (14) in the reverse order of removal.



13. Assemble the hub (8) in the reverse order of disassembly.

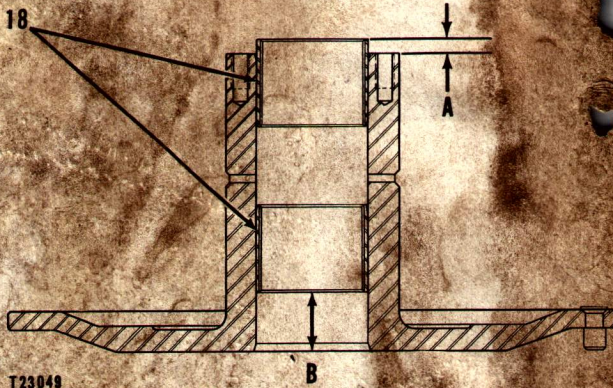

T23049

**BUSHING INSTALLATION**

A- $\frac{1}{4}$ " Dimension. B-1" Dimension. 18-Bushings.