

**NO. 8A, NO. 8S
& NO. 8U
BULLDOZER**

PARTS
Catalog

SERIAL NUMBERS
18C10992 - UP
44C1193 - UP
11C5982 - UP

CATERPILLAR TRACTOR CO.



NO. 8A, NO. 8S & NO. 8U BULLDOZER

HOW TO ORDER PARTS

Please be sure to furnish the quantity, part number and name of each part wanted. It is also important to give the serial number of the machine for which the parts are intended. Location of serial number plates may be determined by referring to the "Specifications" page of this parts catalog. It is suggested that you write the serial number of your machine in this space so that it will be readily available when you need it.

**THIS PARTS CATALOG FOR
MACHINE SERIAL NUMBER**

.....

To insure prompt delivery, please don't overlook furnishing the correct name of the consignee, also the street address, town, county and state to which the parts are to be shipped, and indicate whether shipment is to be made by freight, express, parcel post or by other means.

WHERE TO ORDER PARTS

Caterpillar dealers maintain over 400 stores in the United States, and similar establishments are located strategically in nearly all countries throughout the world. These organizations are backed by the extensive facilities and resources of Caterpillar Tractor Co.

Dealer personnel are factory trained in the stocking and issuing of parts, and large stocks are constantly maintained to insure prompt service. Contact your nearest Caterpillar dealer to make sure that he has your name and address, the correct serial number of your machine, and an accurate list of accessories and attachments. This record will facilitate the issuance of parts when you need them in a hurry.

WHAT THE CATERPILLAR DEALER CAN DO FOR YOU

Caterpillar dealers are in the business of making it economical and profitable for you to own and operate Caterpillar machinery. They are in constant touch with the factory for new developments in repair and maintenance methods, operating procedures, and parts requirements. Their parts stocks are active and up-to-date, including all parts normally required to protect your investment in Caterpillar machinery.

Nearly all Caterpillar dealers offer 24-hour emergency service. For quick reference, write the name and address of the local dealer on your desk pad or the front of your phone book.

ONLY CATERPILLAR PARTS GIVE CATERPILLAR PERFORMANCE

The same quality and craftsmanship that has made Caterpillar products famous throughout the world is built into all Caterpillar replacement parts.

REVISION PUBLISHED JULY 1956

FRANÇAIS

REDACTION DES COMMANDES DE PIÈCES. Pour chaque pièce, indiquer la quantité, le numéro et la désignation. Le numéro de série de la machine à laquelle les pièces sont destinées est également indispensable. Nous vous conseillons d'inscrire le numéro de série de votre machine à la première page de ce catalogue, dans l'espace réservé à cet effet, de façon à le trouver facilement en toutes circonstances.

Pour obtenir une livraison rapide, nous vous prions d'indiquer très exactement le nom du destinataire et son adresse complète: rue, numéro, ville, département, en stipulant, par exemple: petite ou grande vitesse, colis postal, ou tout autre mode d'expédition.

PASSATION DES COMMANDES. Le réseau des Distributeurs Caterpillar couvre le monde entier avec ateliers et dépôts dans la plupart des grands centres. Toute cette organisation repose, en outre, sur l'expérience et les moyens techniques de la Caterpillar Tractor Co.

Les Distributeurs Caterpillar disposent d'un personnel formé à l'usine, parfaitement au courant de tous les problèmes que soulèvent le stockage et la distribution de pièces de rechange. On trouve toujours chez eux un assortiment complet de pièces, ce qui leur permet de servir rapidement les usagers. Mettez-vous en rapport avec le Distributeur Caterpillar le plus proche, assurez-vous qu'il connaît votre nom et votre adresse, le numéro de série de votre machine et les accessoires qui l'équipent. Ces renseignements lui seront utiles, surtout pour les dépannages urgents.

DISTRIBUTEURS CATERPILLAR. Les Distributeurs Caterpillar sont au service de l'utilisateur pour lui faciliter la parfaite utilisation de son matériel. Par leurs rapports constants avec l'usine, ils sont toujours au courant des toutes dernières méthodes de réparation, d'entretien, d'emploi du matériel et de remplacement des pièces. Ils veillent, en particulier, à ce que leur stock de pièces réponde par sa composition aux besoins éventuels de tous les propriétaires de matériel Caterpillar, quel que soit l'âge de leur machine, pour réduire au strict minimum les arrêts toujours très coûteux.

Presque tous nos Distributeurs ont une permanence de jour et de nuit pour les appels urgents. Afin d'éviter toute perte de temps, ayez toujours à portée de la main le nom et l'adresse de votre Distributeur Caterpillar.

RIEN NE SAURAIT SE SUBSTITUER A LA PIÈCE AUTHENTIQUE CATERPILLAR. La qualité et la construction soignée qui ont fait la réputation mondiale du matériel Caterpillar se retrouvent dans toutes les pièces d'origine.

ITALIANO

MODO DI ORDINARE LE PARTI DI RICAMBIO. Vi preghiamo di indicare con precisione la quantità, il numero e la denominazione di ogni parte richiesta. È altresì importante precisare il numero di serie della macchina sulla quale dovrà essere montata la parte. Vi consigliamo di scrivere il numero di serie della Vostra macchina nello spazio predisposto a questo scopo nella prima pagina di questo catalogo parti.

Per assicurare la pronta consegna, Vi preghiamo di non mancare di fornire il nome del destinatario, correttamente scritto, come pure l'indirizzo, cioè la strada, la città, la provincia e lo stato dove le parti dovranno essere spedite, indicando se la spedizione dovrà essere effettuata per ferrovia, per mare, per espresso, per pacco postale o per altro mezzo.

DOVE SI ORDINANO LE PARTI. I vari Distributori CATERPILLAR hanno organizzato oltre 400 depositi di parti di ricambio negli Stati Uniti e simili depositi si trovano convenientemente situati in quasi tutti i paesi del mondo. Questi depositi usufruiscono del vantaggio delle adeguate facilitazioni e delle forti risorse della CATERPILLAR TRACTOR CO. Il personale dei Distributori viene istruito dalla fabbrica per il mantenimento degli assortimenti e per la consegna delle parti. Vasti depositi vengono continuamente riforniti per assicurare la pronta consegna. MetteteVi in comunicazione con il Distributore CATERPILLAR più vicino a Voi ed assicurate Vi che egli abbia il Vostro nome e indirizzo, l'esatto numero di serie della Vostra macchina ed una larga disponibilità di accessori vari. In questa maniera faciliterete la consegna delle parti quando ne avrete urgente necessità.

CIÒ CHE PUÒ FARE PER VOI IL DISTRIBUTORE CATERPILLAR. I Distributori CATERPILLAR hanno principalmente lo scopo di rendere economico e vantaggioso per Voi il possesso e l'uso dei macchinari CATERPILLAR. Essi sono costantemente in comunicazione con la fabbrica e perciò al corrente dei miglioramenti introdotti nei sistemi di riparazione, di manutenzione e di impiego delle macchine, nonché nella richiesta di parti di ricambio.

I loro assortimenti sono efficienti e continuamente aggiornati. Essi comprendono tutti i pezzi che normalmente sono richiesti per garantire il capitale da Voi impiegato in macchinari CATERPILLAR.

Quasi tutti i Distributori CATERPILLAR offrono giorno e notte servizio per casi urgenti.

Per rapidità di riferimento, segnate il nome e l'indirizzo del Vostro rivenditore locale sulla rubrica della Vostra scrivania o nella testata della vostra guida telefonica.

SOLTANTO LE PARTI CATERPILLAR GARANTISCONO LA FAMA DELLA MARCA CATERPILLAR. Le parti di ricambio CATERPILLAR vengono costruite con i materiali e con i sistemi di lavorazione che hanno resi famosi in tutto il mondo i prodotti CATERPILLAR.

DEUTSCH

WIE MAN ERSATZTEILE BESTELLT. Bitte übersehen Sie nicht, bei jedem Ersatzteilposten die Anzahl, Nummer und Bezeichnung genau anzugeben. Ebenso wichtig ist es, die Seriennummer der Maschine aufzuführen, auf die die Teile passen sollen. Wir möchten Ihnen empfehlen, diese Seriennummer in dem dafür vorgesehenen Rechteck auf der ersten Seite dieses Katalogs einzutragen, damit sie stets schnell zu finden ist.

Um alle Zeitverluste bei der Lieferung zu vermeiden, ist es ratsam, den vollen Namen, sowie den Staat, das Land, die Stadt, die Straße und die Hausnummer des jeweiligen Empfängers genau anzugeben, wobei am besten auch die Verschiffungsart (Fracht, Eilgut, Postpaket, usw.) ausdrücklich vorzuschreiben ist.

WO MAN ERSATZTEILE BESTELLT. In fast allen Ländern der Welt bestehen Caterpillar-Vertretungen. Diese Firmen stehen in enger Fühlung mit der Hauptfabrik, bei der sie in vielen Fragen Rat und weitgehende Unterstützung finden.

Zwecks prompter Belieferung der Kundschaft aus ihren gut eingerichteten Ersatzteillagern verfügen diese Vertretungen über ein zahlreiches Personal, das in der Fabrik Schulung im Lagern und Ausfolgen von Ersatzteilen erhalten hat. Es liegt in Ihrem Interesse, sich zu vergewissern, daß Ihre Anschrift, die Seriennummer und eine vollständige Beschreibung Ihrer Maschine, einschließlich allem Zubehör und Zusatzapparaten bei Ihrer zuständigen Vertretung vorliegen, so daß Rückfragen sich erübrigen, falls dringende Bestellungen beschleunigt bearbeitet werden müssen.

AUFGABE DER CATERPILLAR-VERTRETUNG. Es ist die Aufgabe der Caterpillar-Vertretung, dafür zu sorgen, daß es für Sie vorteilhaft und einträglich ist, unser Gerät zu erwerben und damit zu arbeiten. Durch ihre Verbindung mit der Zentrale kennt sie stets die neuesten Methoden, solche Maschinen zu benutzen, instand zu halten und zu reparieren, sowie die Einzelteile, die dazu erforderlich sind. Ihr modernes Lager entspricht dem vorausgerechneten Bedarf ihrer Kundschaft, wobei besonderer Nachdruck auf die Teile gelegt wird, die sich erfahrungsgemäß schneller abnutzen. So ist sie in der Lage, diese Produktionsmittel in arbeitsfähigem Zustand zu erhalten und das in ihnen investierte Kapital vor Verlusten zu bewahren.

Bei fast allen Caterpillar-Vertretungen besteht ein Notdienst, Tag und Nacht. Um die Anschrift und Telefonnummer der nächsten Zweigstelle an der Hand zu haben, empfiehlt es sich, sie vorn auf Ihrem Adreß- oder Telefonbuch zu vermerken.

WIR WARNEN VOR NACHAHMUNGEN. Die Qualität und Werkarbeit, die den Weltruf der Caterpillar-Geräte begründet haben, findet man nur bei unseren Original-Ersatzteilen.

ESPAÑOL

COMO PEDIR PIEZAS DE REPUESTO. Es necesario indicar la cantidad, el número y el nombre de las piezas que se deseen. Es también importante dar el número de serie de la máquina para la cual se desean las piezas. Se sugiere que usted anote este número de serie de su máquina en el espacio que se ha dejado en la primera página, de manera que lo tenga siempre a mano cuando lo necesite.

Para que el despacho se efectúe con prontitud, es necesario que se dé el nombre correcto del consignatario, así como la dirección, además de los nombres de la provincia, y departamento o estado a que han de enviarse las piezas. Asimismo, debe especificarse el medio a utilizarse, si debe ser hecho como carga, o por expreso, paquete postal o en otra forma.

DONDE PEDIR LAS PIEZAS. Hay más de 400 establecimientos de los Distribuidores CATERPILLAR en los Estados Unidos, y en casi todo el mundo existen otros, similares, estratégicamente ubicados. Estas organizaciones están respaldadas por las extensas facilidades y recursos de Caterpillar Tractor Co.

El personal de los Distribuidores ha recibido su entrenamiento en la fábrica, en el almacenamiento y despacho de partes. Mantiene, además, grandes existencias de partes para asegurar un servicio rápido. Póngase en contacto con su Distribuidor CATERPILLAR para asegurarse de que tiene su nombre y dirección, el número de serie correcto de su máquina y una lista exacta de partes y accesorios. Este registro facilitará el despacho de partes cuando usted las necesite con urgencia.

LO QUE EL DISTRIBUIDOR CATERPILLAR PUEDE HACER POR USTED. Los Distribuidores tienen como objetivo el hacer económico y provechoso para usted poseer y trabajar maquinaria CATERPILLAR. Ellos están en contacto permanente con la fábrica para tener los últimos adelantos en los métodos de reparación y mantenimiento, procedimientos de trabajo y requerimientos de partes. Sus existencias de partes tienen gran movimiento y están siempre al día, incluyendo todas las partes normalmente requeridas para proteger su inversión en maquinaria CATERPILLAR.

Casi todos los Distribuidores ofrecen servicio de emergencia de día y de noche. Para referencia rápida, escriba el nombre y dirección de su Distribuidor local en la carpeta de su escritorio o en la tapa de su libro de teléfono.

SOLO LAS PIEZAS CATERPILLAR DAN EL RESULTADO APETECIDO. Todas las piezas CATERPILLAR han sido fabricadas según el patrón de alta calidad y mano de obra que ha hecho famosos los productos CATERPILLAR.

PORTUGUÊS

COMO FAZER OS PEDIDOS DE PEÇAS. Ponha no pedido a quantidade, o número e o nome de cada peça desejada. É também preciso pôr-se o número de série da máquina para a qual a peça se destina. Escreva o número de série de sua máquina no espaço para o mesmo reservado na página No. 1, para tê-lo à mão quando o precisar.

Para garantir pronta remessa não deixe de pôr o nome correto do consignatário bem como da rua, cidade, estado e país para onde as peças devem ser despachadas, indicando se o despacho deve ser feito como carga regular, encomenda postal via marítima ou aérea (regular ou expressa) ou qualquer outro modo.

PARA ONDE DIRIGIR OS PEDIDOS DE PEÇAS. Os distribuidores "Caterpillar" mantêm mais de 400 estabelecimentos comerciais nos Estados Unidos e em localizações estrategicamente espalhadas por quase todos os países do mundo. Todas essas organizações contam com o apoio e a cooperação de Caterpillar Tractor Co.

Os distribuidores mantêm, sempre, grande estoque de peças para servir os clientes com presteza. E seu pessoal, treinado na fábrica, sabe como lidar com peças. Comunique-se com o distribuidor "Caterpillar" mais próximo para se certificar se ele tem o seu nome e endereço, o exato número de série de sua máquina e uma lista de seus equipamentos e acessórios. O registro desses dados facilitará a remessa de peças quando as pedir com urgência.

O QUE O DISTRIBUIDOR "CATERPILLAR" PODE FAZER PARA LHE SERVIR. Nossos distribuidores têm interesse em tornar econômica e lucrativa a posse e o uso de nossas máquinas. Mantendo constante contato com a fábrica, estão sempre bem informados sobre os métodos mais modernos empregados para manobrá-las, conservá-las e repará-las, bem como sobre tudo que se refere a peças de substituição. Têm em estoque peças para qualquer máquina existente no território a seu cargo e em quantidade suficiente para evitar que as máquinas fiquem paradas.

Quase todos os distribuidores "Caterpillar" têm serviço mecânico de emergência aberto dia e noite. Para uma rápida referência, escreva o nome e o endereço do seu distribuidor no bloco de notas de sua escrevaninha ou na sua lista de telefone.

PEÇAS "CATERPILLAR" SÃO AS ÚNICAS RECOMENDÁVEIS. As peças "Caterpillar" são feitas conforme o padrão de alta qualidade e a técnica de fabricação que tornaram os produtos "Caterpillar" famosos em todo o mundo.

INDEX

Name	Page
Bracket—Cylinder	32
Brace—No. 8A	10
Brace—No. 8S	13
Brace—No. 8U	15
Bracket—Sheave	18
Blade—No. 8A	8
Blade—No. 8S	12
Blade—No. 8U	14
Cable and Guard	24
Cable Cutter	41
C-Frame	9
Cylinder—Hydraulic	34
Hitch—Sheave	22
Numerical Parts Index	46
Push Arm—No. 8S	13
Push Arm—No. 8U	15
Push Cup	40
Sheaves	19
Specifications	48
Support—Cylinder	31
Support—Sheave	16
Trunnion	38

INDEX ALPHABÉTIQUE

Désignation	Page
Bras de Bulldozer N° 8S	13
Bras de Bulldozer N° 8U	15
Câble et protecteurs	24
Caractéristiques	48
Châssis en U	9
Cisaille à câble	41
Index numérique des pièces	46
Lame N° 8A	8
Lame N° 8S	12
Lame N° 8U	14
Palonnier de moufle	22
Plaques-support et tourillons de vérin	32
Poulies et moufles	19
Protège-radiateur et supports de moufle	16
Protège-radiateur et tourillons de vérin	31
Support de moufles	18
Tampon de poussée	40
Tirants de réglage pour N° 8A	10
Tirants de réglage pour N° 8S	13
Tirants de réglage pour N° 8U	15
Tourillons de bulldozer	38
Vérins hydrauliques	34

INDICE

Nombre	Página
Abrazadera de la Polea	18
Abrazadera del Cilindro	32
Bastidor U	9
Brazos de Empuje—No. 8S	13
Brazos de Empuje—No. 8U	15
Cable y Protección	24
Caja de Empuje	40
Cilindro Hidráulico	34
Cortador de Cable	41
Enganche—Polea	22
Especificaciones	48
Hoja—No. 8A	8
Hoja—No. 8S	12
Hoja—No. 8U	14
Índice Numérico de Partes	46
Muñón	38
Poleas	19
Soporte de la Polea	16
Soporte del Cilindro	31
Tirante—No. 8A	10
Tirante—No. 8S	13
Tirante—No. 8U	15

ÍNDICE

Nomenclatura	Página
Apoio do cilindro	32
Armação "U"	9
Braços do No 8A	10
Braços do No 8S	13
Braços do No 8U	15
Braços laterais do No 8S	13
Braços laterais do No 8U	15
Cabo e protetor	24
Chapa de empuxo	40
Cilindro hidráulico	34
Cortador de cabo	41
Engate da roldana	22
Especificações	48
Índice numérico de peças	46
Lâmina do No 8A	8
Lâmina do No 8S	12
Lâmina do No 8U	14
Munhão	38
Roldanas	19
Suporte da roldana	16
Suporte da roldana	18
Suporte do cilindro	31

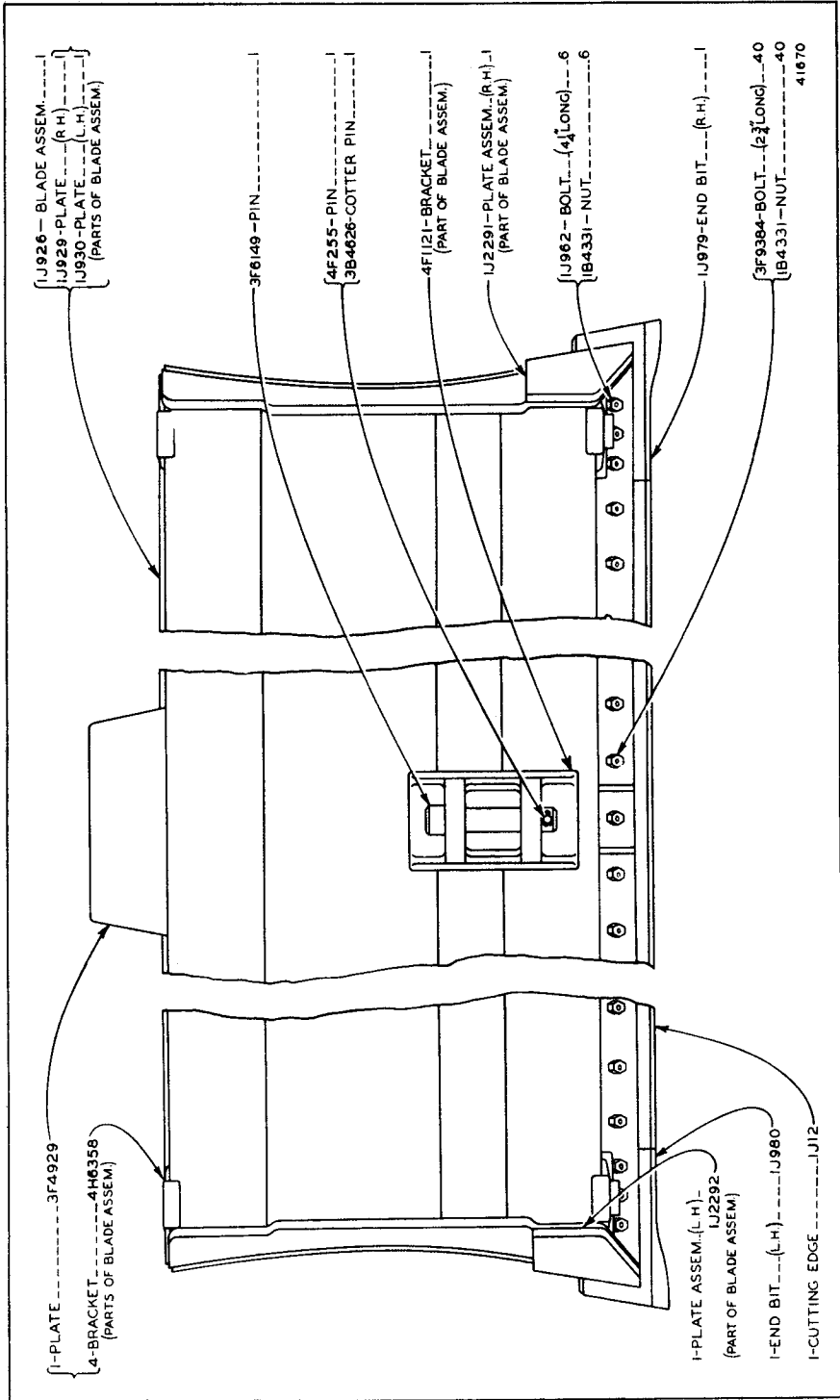

IJ963 BLADE GROUP
 (CABLE OR HYDRAULIC OPERATED)
 Effective with No. 8A Bulldozer Serial No. 18C10992.

ALWAYS GIVE SERIAL NUMBER WHEN ORDERING PARTS

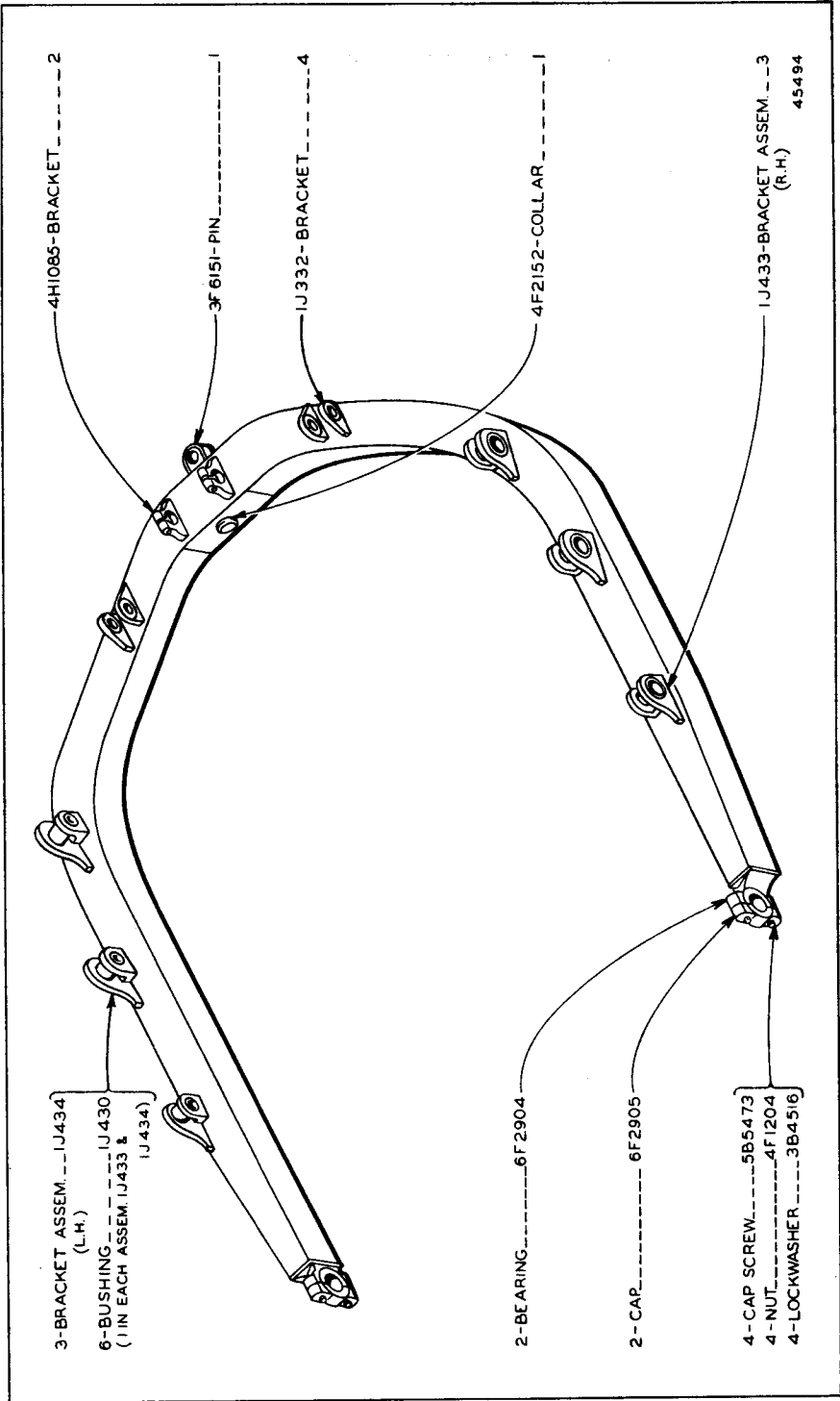

IJ377 C-FRAME GROUP
 Effective with No. 8A Bulldozer Serial No. 18C10992

ONLY "CATERPILLAR" PARTS GIVE "CATERPILLAR" PERFORMANCE

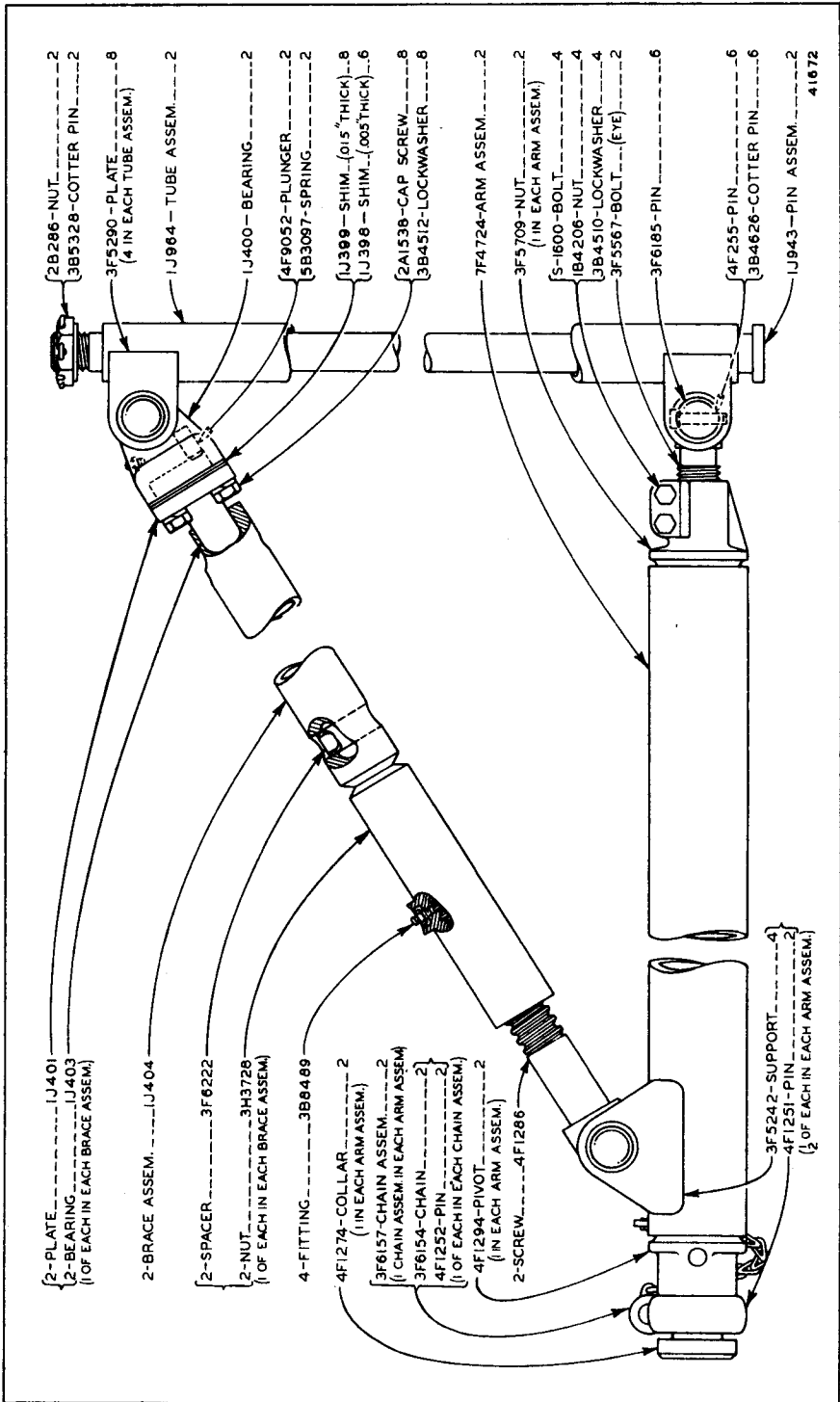

IJ405 BRACE GROUP
 Effective with No. 8A Bulldozer Serial No. 18C10992

ALWAYS GIVE SERIAL NUMBER WHEN ORDERING PARTS

EXPERIENCE

Saves You Time and Money

The courteous partsman who waits on you at your Caterpillar Dealer's store knows your equipment and your needs. His knowledge can speed delivery of your parts orders and insure that the parts you get are the parts you want.

Call on him—*anytime!*

La experiencia que le economiza tiempo y dinero

El técnico de repuestos de su Distribuidor Caterpillar conoce su equipo y sus necesidades. Sus conocimientos pueden acelerar la entrega de los repuestos que usted necesita y asegurar que los repuestos que usted obtenga sean las piezas que usted necesita.

¡ Llámelo . . . cuando usted quiera!

A experiência economiza tempo e dinheiro

O empregado do distribuidor Caterpillar que lhe atende quando você precisa de peças, conhece a sua máquina e do que ela necessita. Seu conhecimento contribui para apressar a entrega de seus pedidos de peças e é uma garantia de que lhe dará as peças que precisa.

Chame-o a qualquer hora!

Un personnel expérimenté vous économise du temps et de l'argent

Chez votre concessionnaire Caterpillar, les employés du Service Pièces de rechange sont des gens compétents qui connaissent à fond le matériel. Sans perte de temps, sans difficulté, ils vous procureront exactement les pièces dont vous avez besoin.

Adressez-vous en toute confiance à votre concessionnaire Caterpillar.



**SPECIFY GENUINE
CATERPILLAR
PARTS**

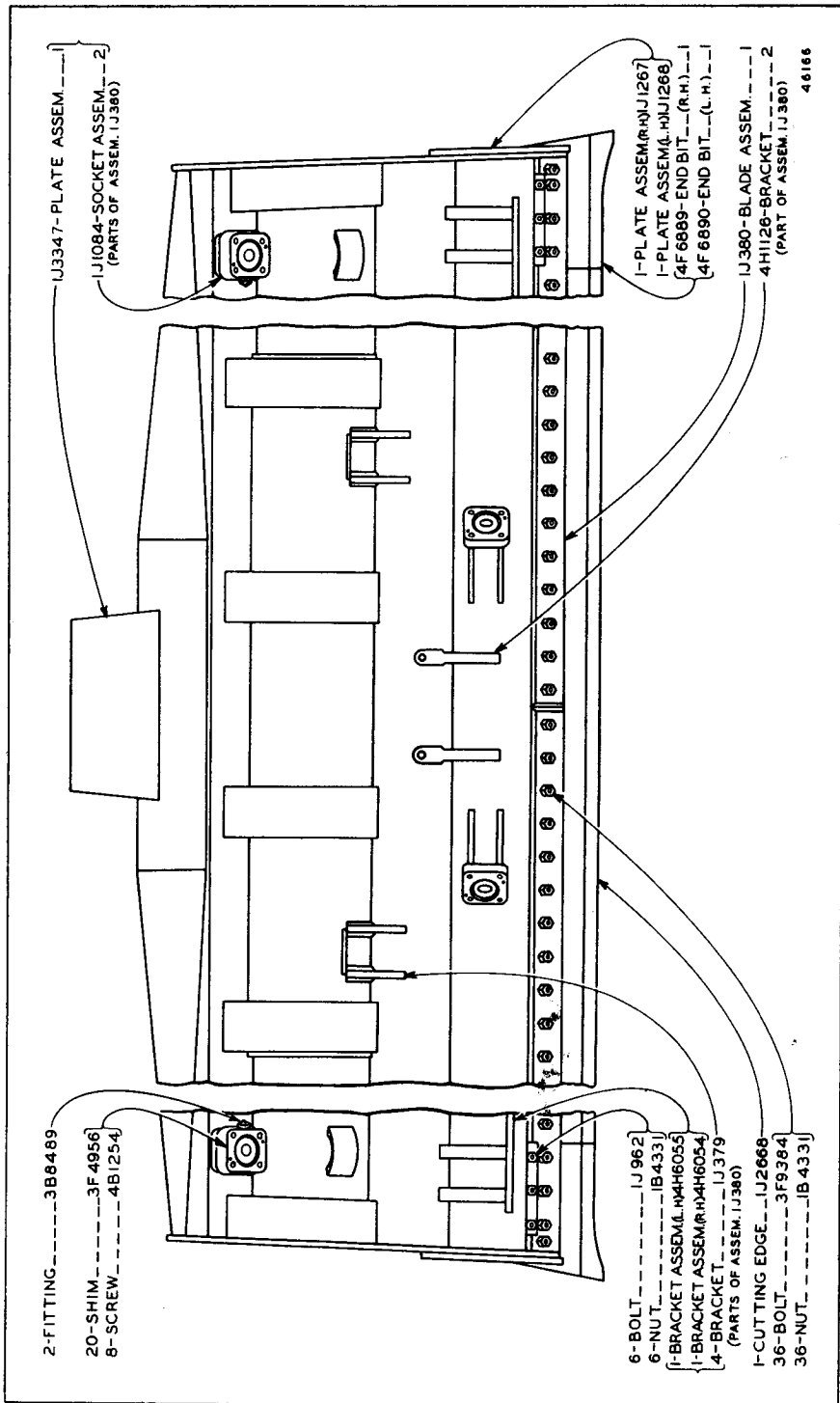

IJ378 BLADE GROUP
 (CABLE OR HYDRAULIC OPERATED)
 Effective with No. 8S Bulldozer Serial No. 44C1193

ALWAYS GIVE SERIAL NUMBER WHEN ORDERING PARTS

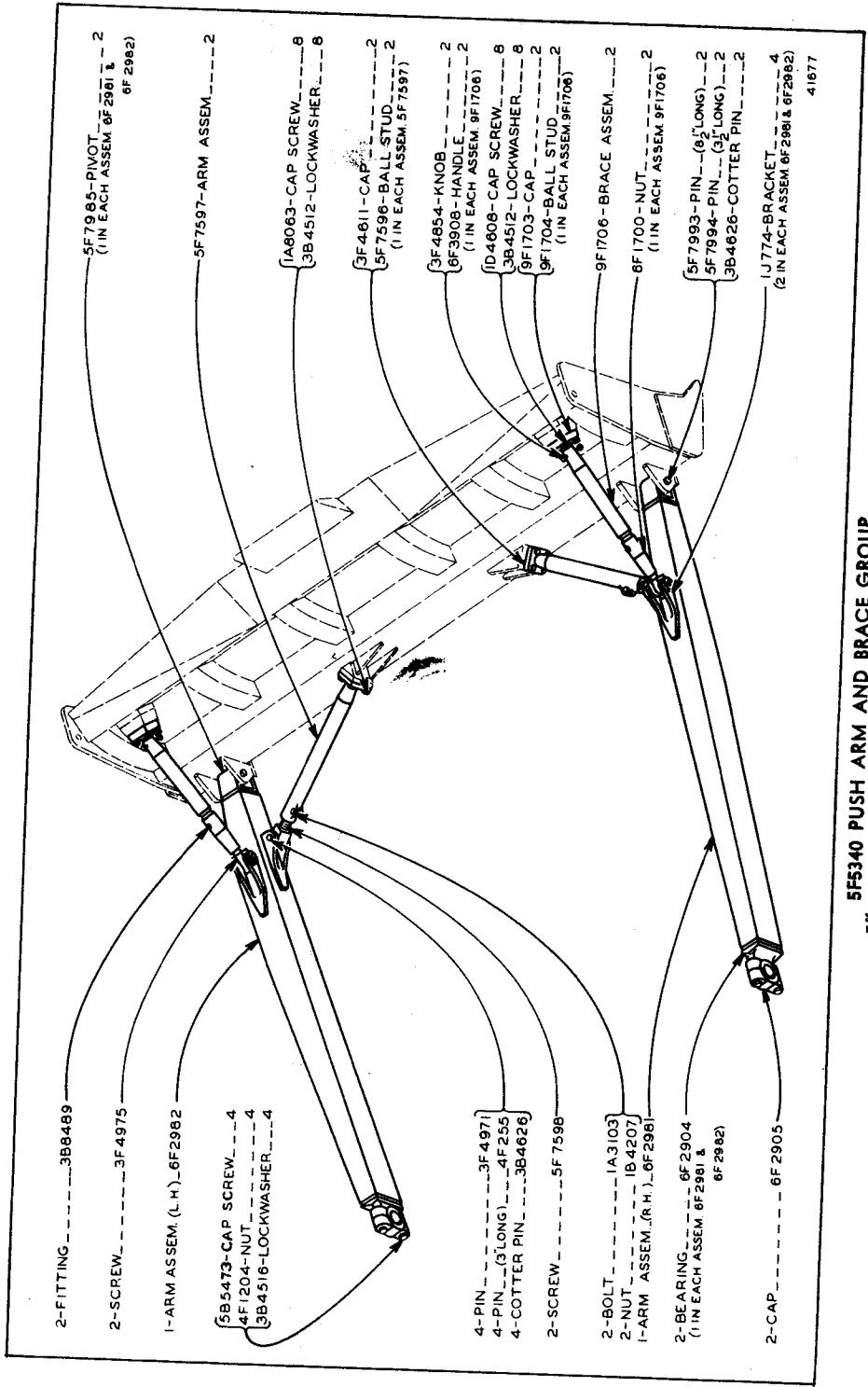

5F5340 PUSH ARM AND BRACE GROUP
Effective with No. 85 Bulldozer Serial No. 44C1193

ONLY "CATERPILLAR" PARTS GIVE "CATERPILLAR" PERFORMANCE

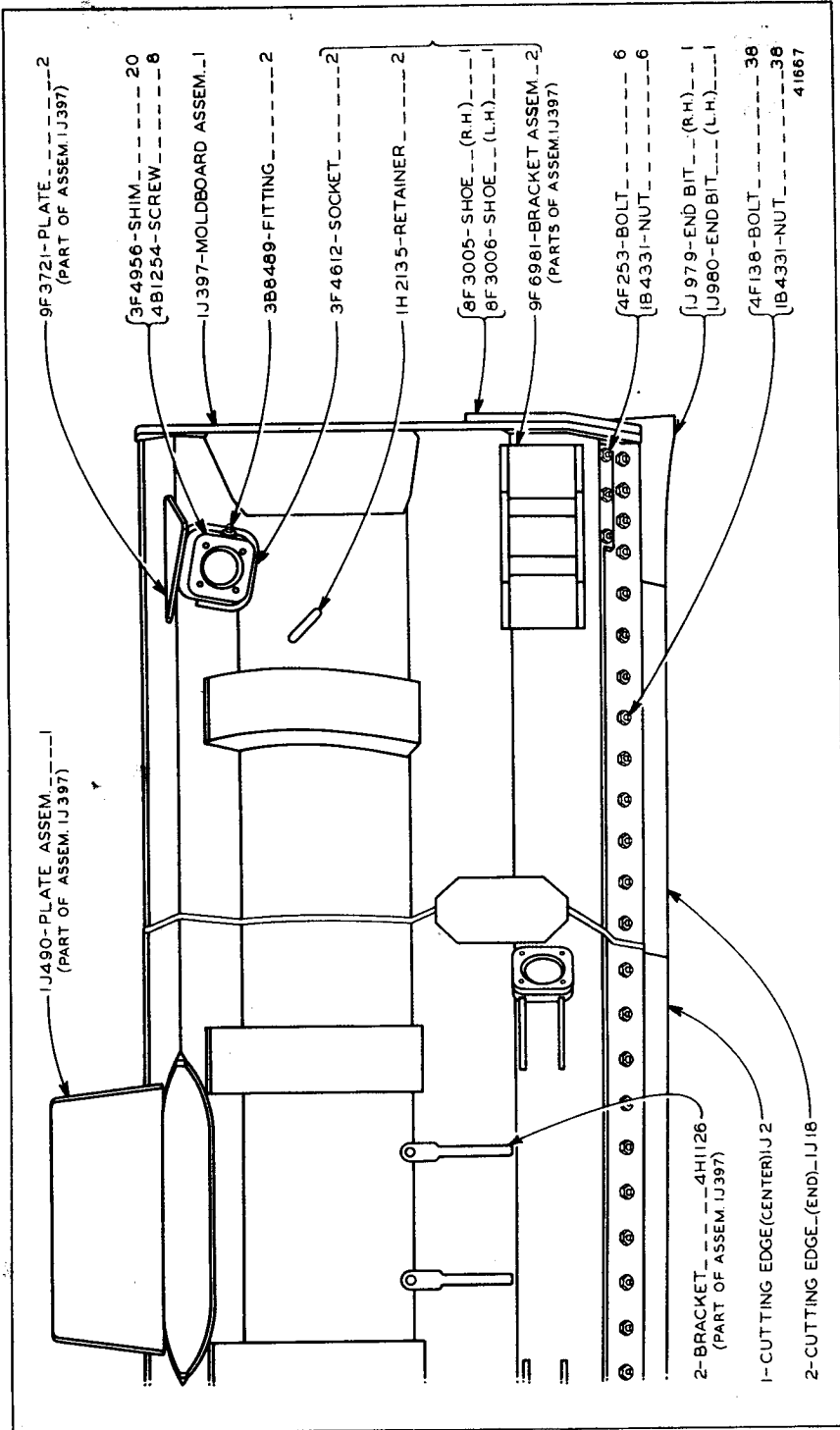

IJ406 BLADE GROUP
(CABLE OPERATED ONLY)

Effective with No. 8U Bulldozer Serial No. 11C5982

For use on D8 Tractors having Serial No. 2U9662 to 2U23537, 13A1 to 13A3703, 14A1—Up and 15A1—Up

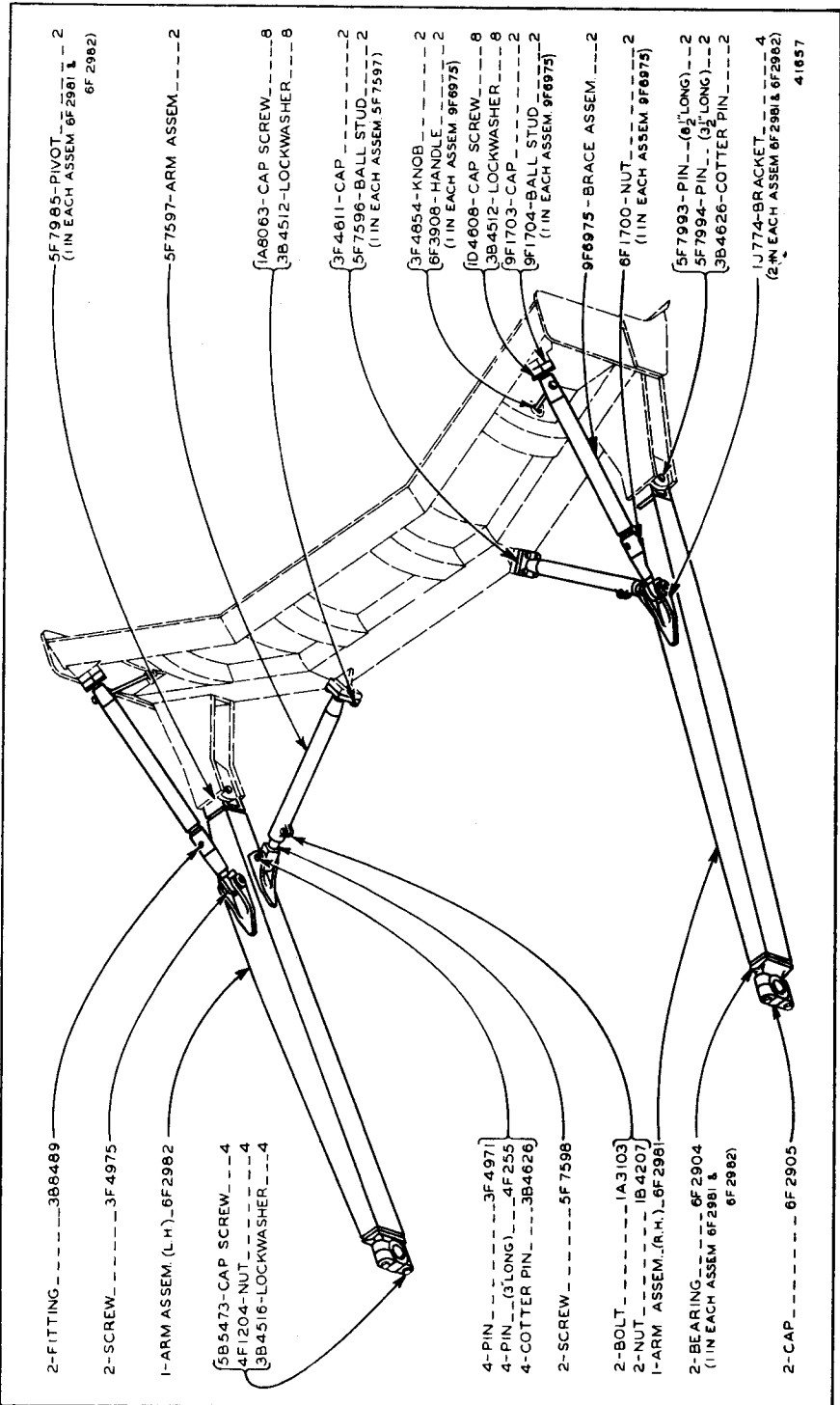

IJ764 PUSH ARM AND BRACE GROUP
 Effective with No. 8U Bulldozer Serial No. 11C5982
 For use on D8 Tractors having Serial No. 2U9662 to 2U23537, 13A1 to 13A3703, 14A1—Up and 15A1—Up

ONLY "CATERPILLAR" PARTS GIVE "CATERPILLAR" PERFORMANCE

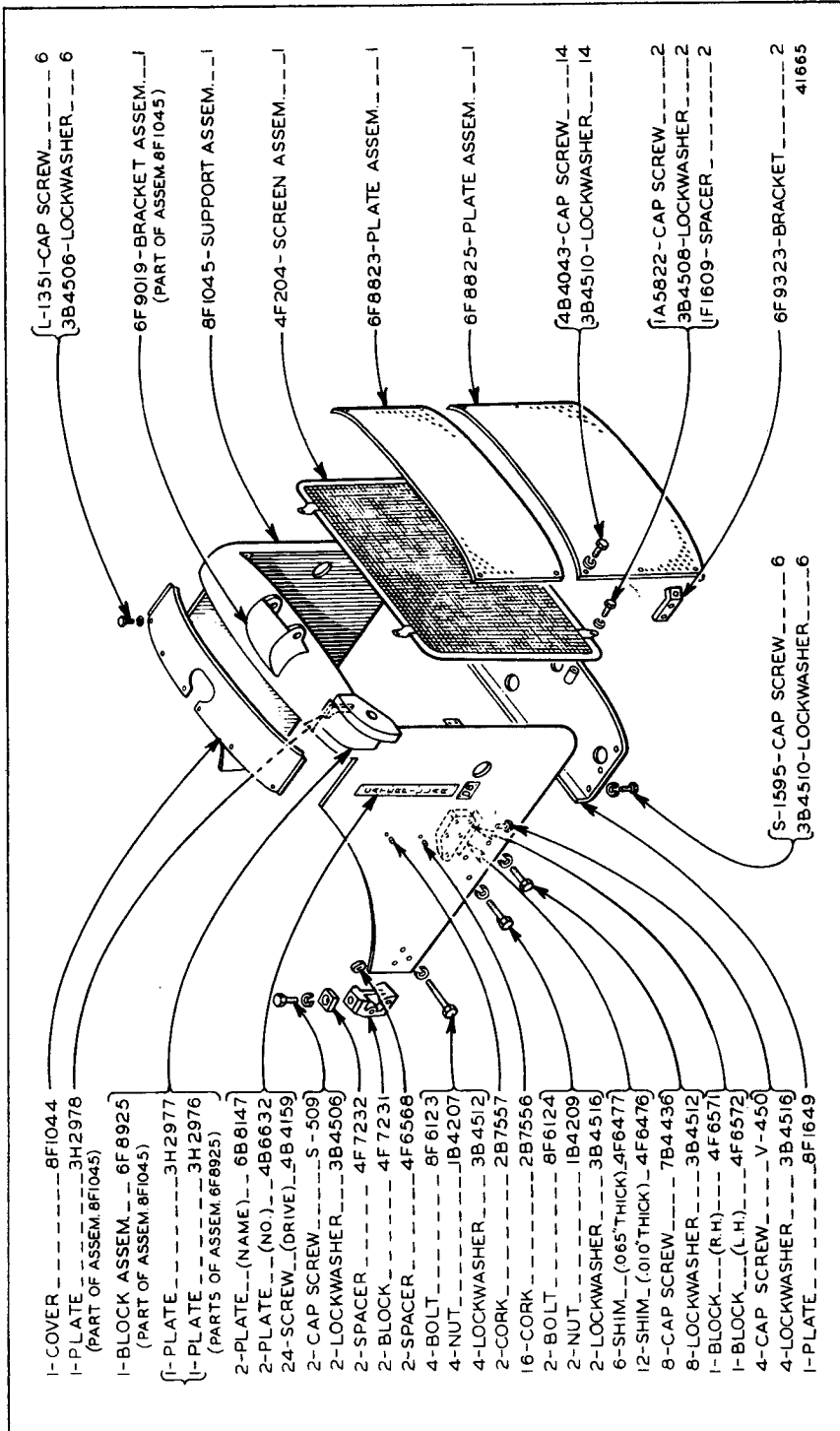

8F1046 SHEAVE SUPPORT GROUP
 Effective with No. 8S Bulldozer Serial No. 44C1193
 For use with No. 25 Cable Control

For use on D8 Tractors having Serial No. 5E8001 to 5E8035, 1H1 to 1H9999, 8R1 to 8R9999 and 2U1 to 2U9661 inclusive

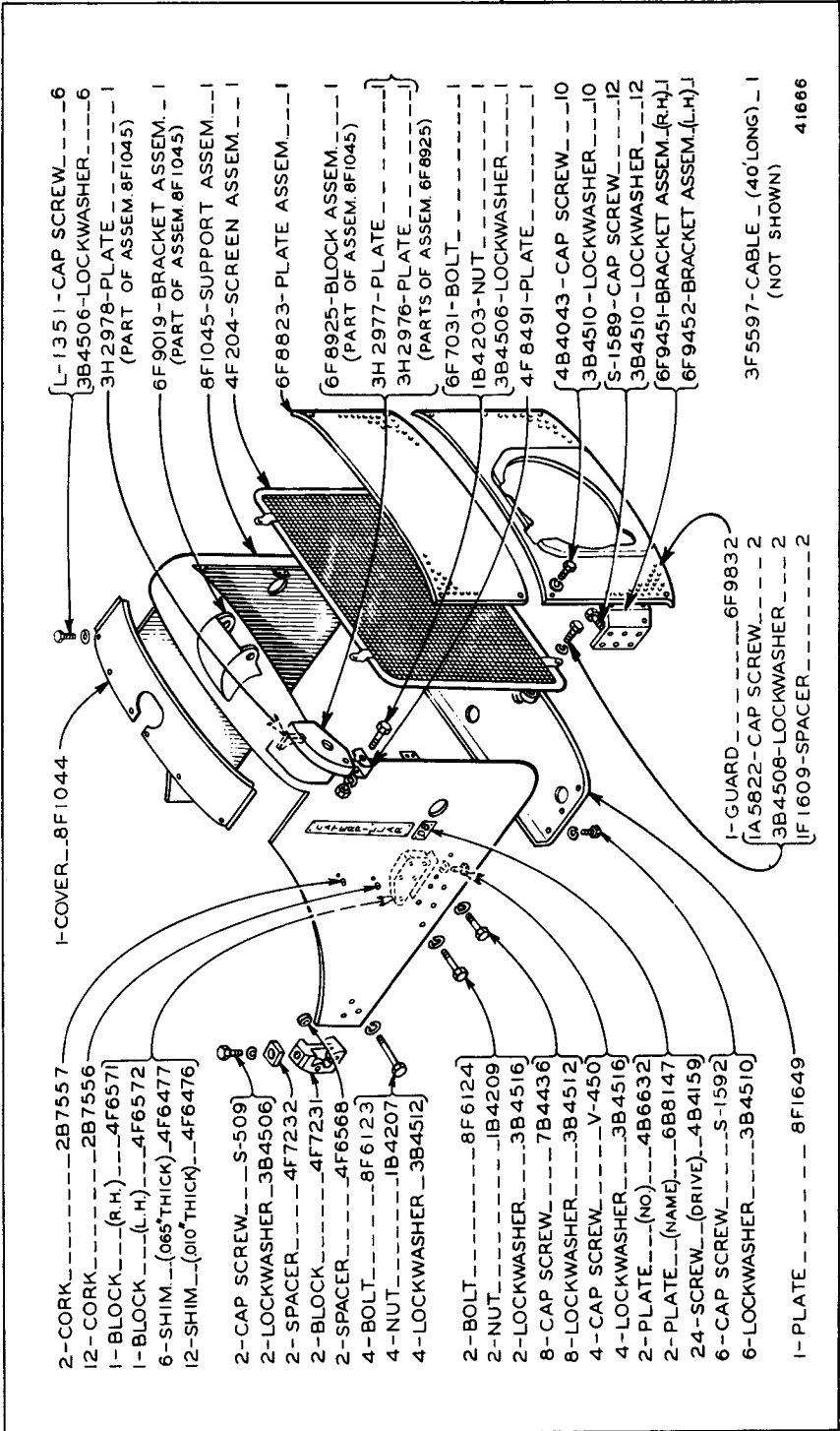

8F1932 SHEAVE SUPPORT GROUP

Effective with No. 8A Bulldozer Serial No. 18C10992 and No. 8S Bulldozer Serial No. 44C1193

For use with No. 24 Cable Control
For use on D8 Tractors having Serial No. 5E8001 to 5E8035, 1H1 to 1H9999, 8R1 to 8R9999 and 2U1 to 2U9661 inclusive

41666

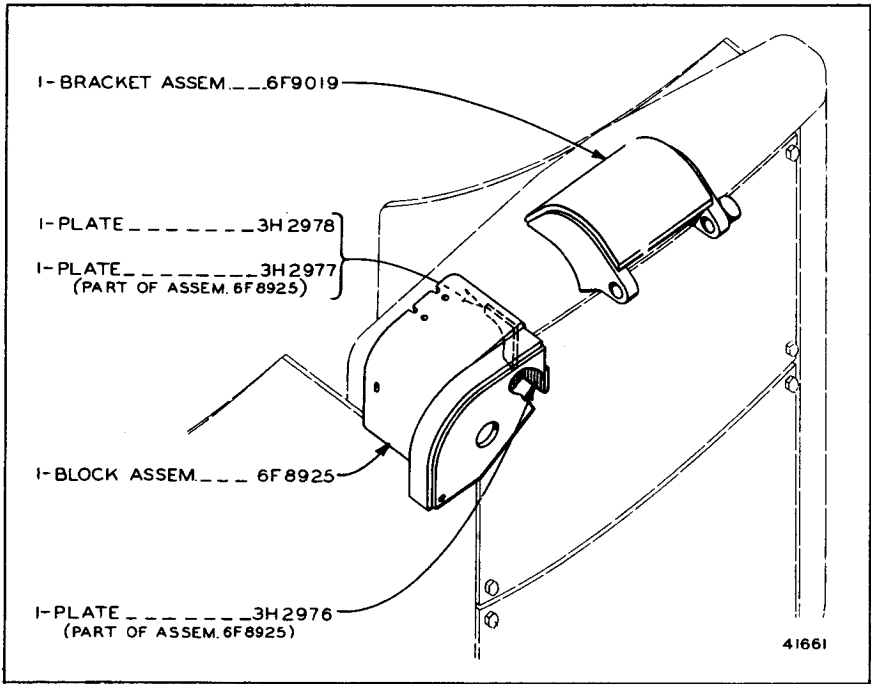

6F9042 SHEAVE BRACKET GROUP

For use on D8 Tractors having Serial No. 2U9662 to 2U23537
and 13A1 to 13A3703 inclusive

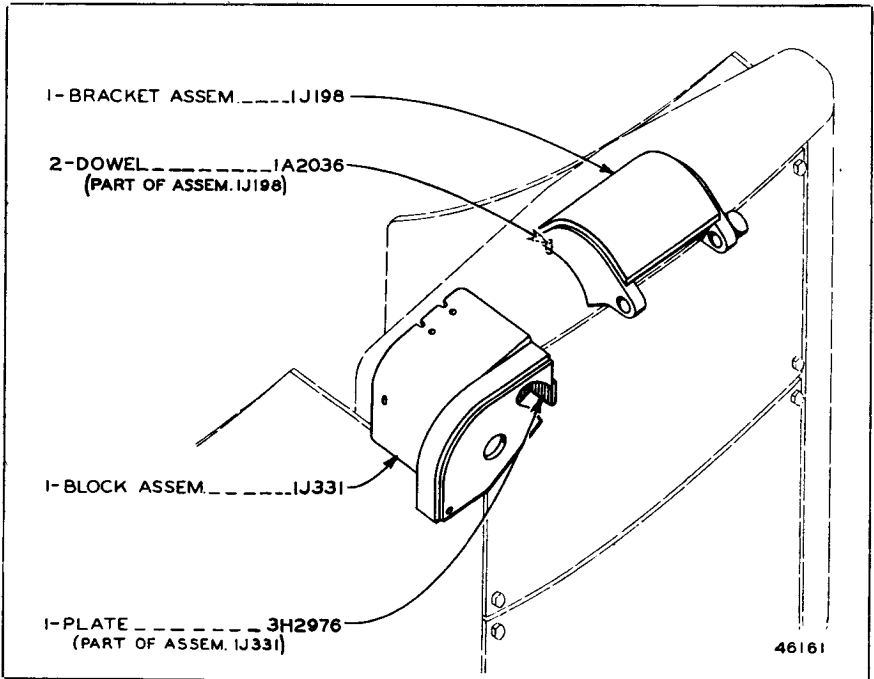

1J199 SHEAVE BRACKET GROUP

For use on D8 Tractors having Serial No. 14A1—Up and 15A1—Up

ALWAYS GIVE SERIAL NUMBER WHEN ORDERING PARTS

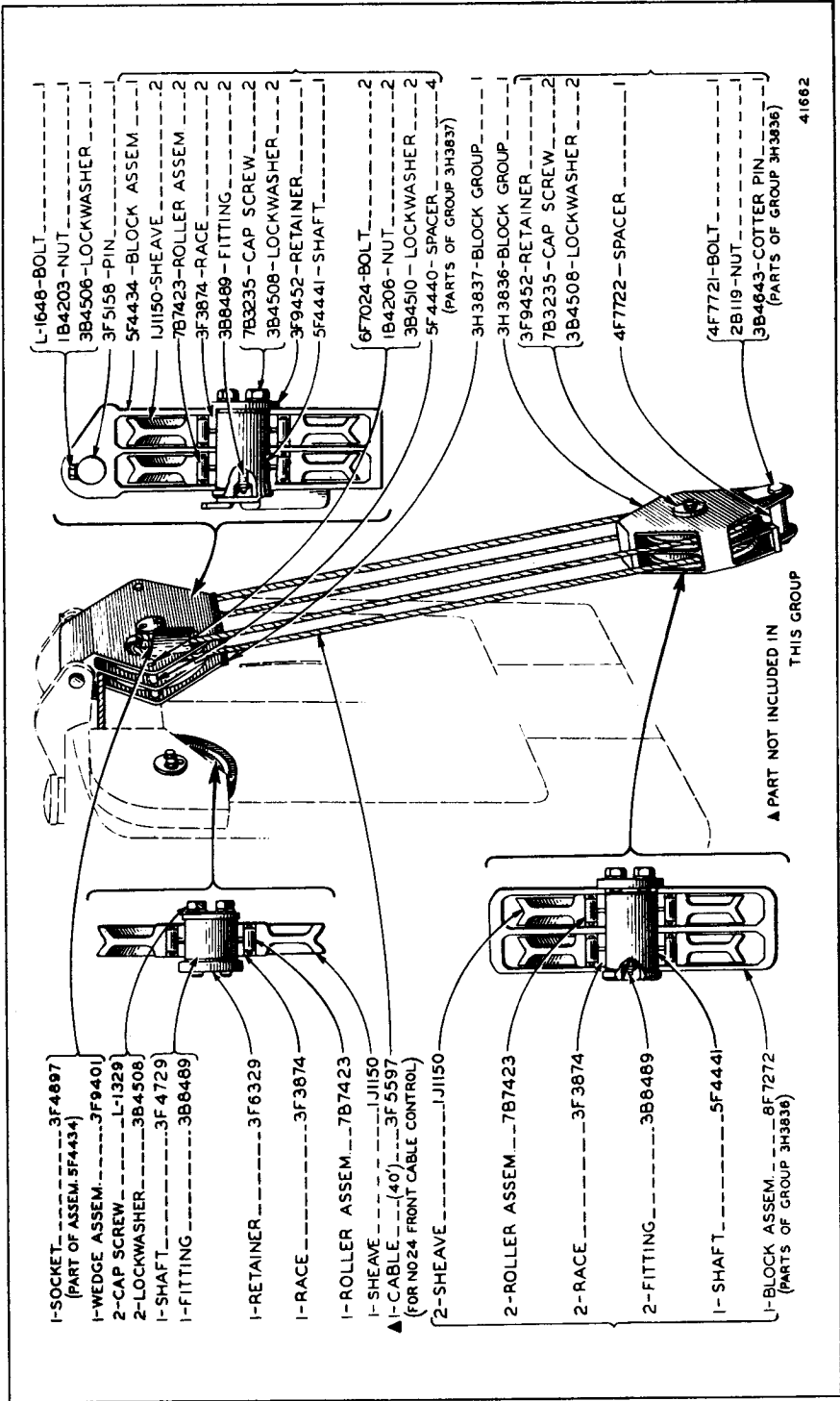

5F4442 SHEAVE GROUP
For use on D8 Tractors having Serial No. 5E8001 to 5E8035, 1H1 to 1H9999, 8R1 to 8R9999, 2U1 to 2U23537 and 13A1 to 13A3703 inclusive

ONLY "CATERPILLAR" PARTS GIVE "CATERPILLAR" PERFORMANCE

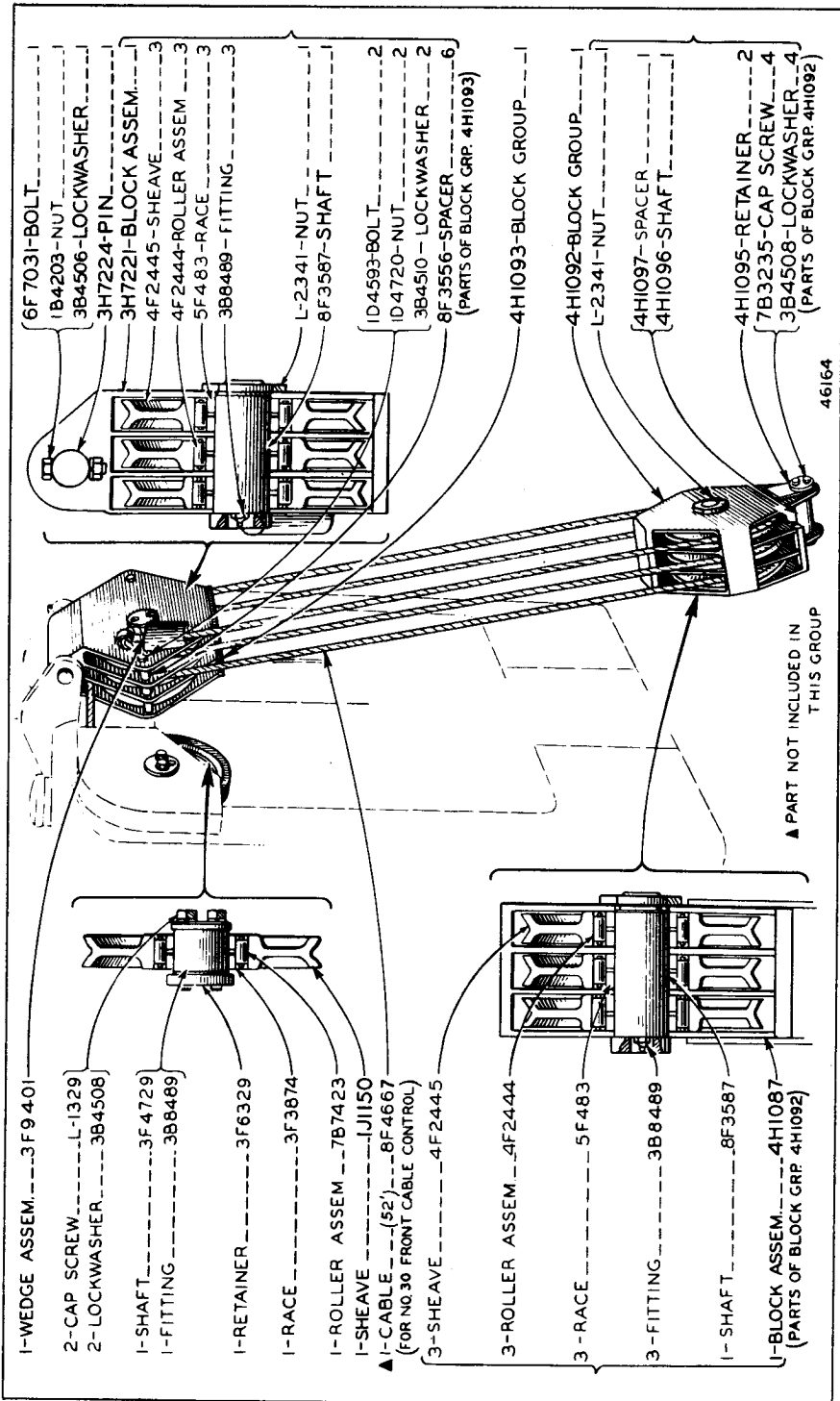

4HI094 SHEAVE GROUP—First Type
 For use on D8 Tractors having Serial No. 14A1—Up and 15A1—Up

ALWAYS GIVE SERIAL NUMBER WHEN ORDERING PARTS

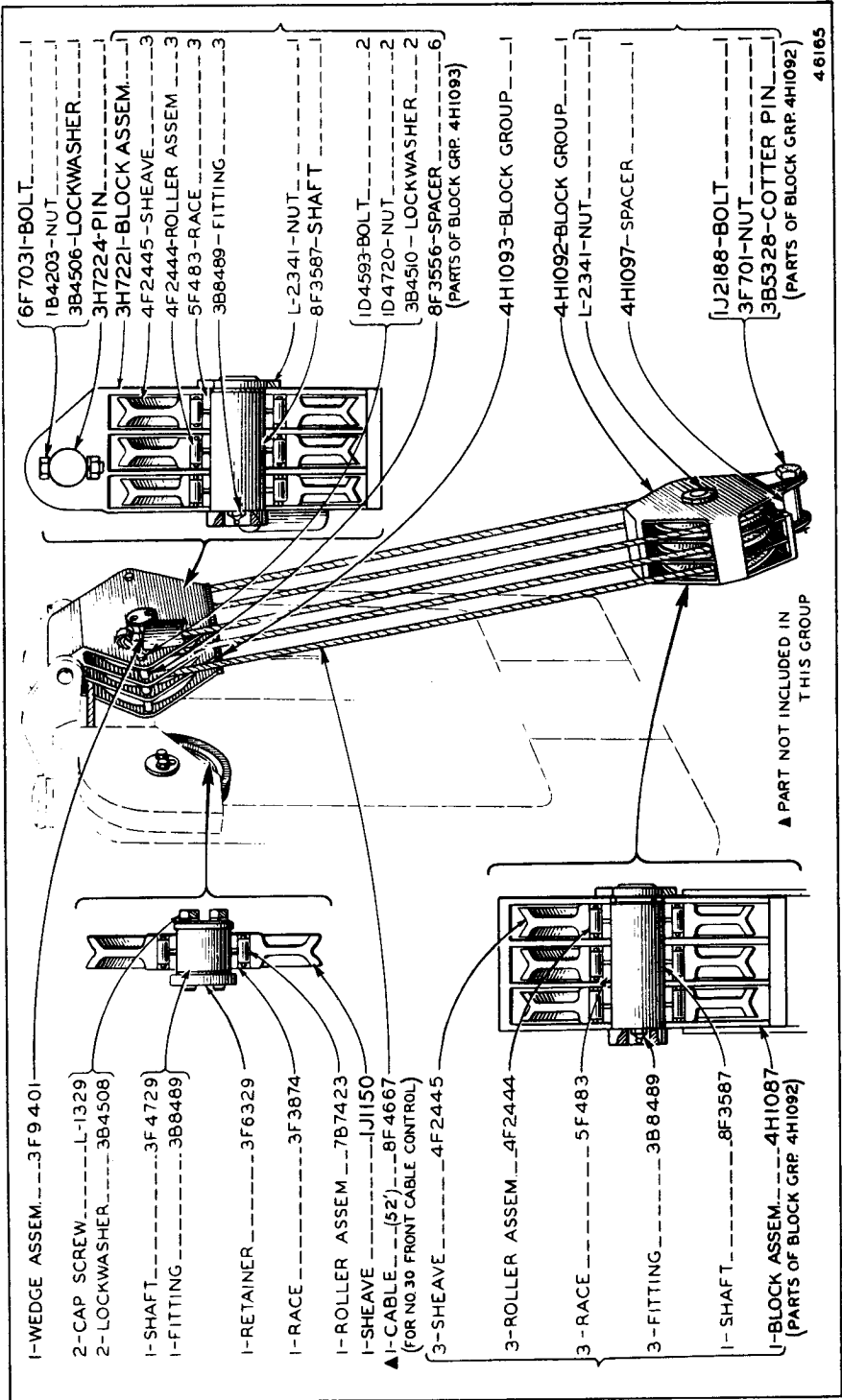

4H1094 SHEAVE GROUP—Second Type
 For use on D8 Tractors having Serial No. 14A1—Up and 15A1—Up

ONLY "CATERPILLAR" PARTS GIVE "CATERPILLAR" PERFORMANCE

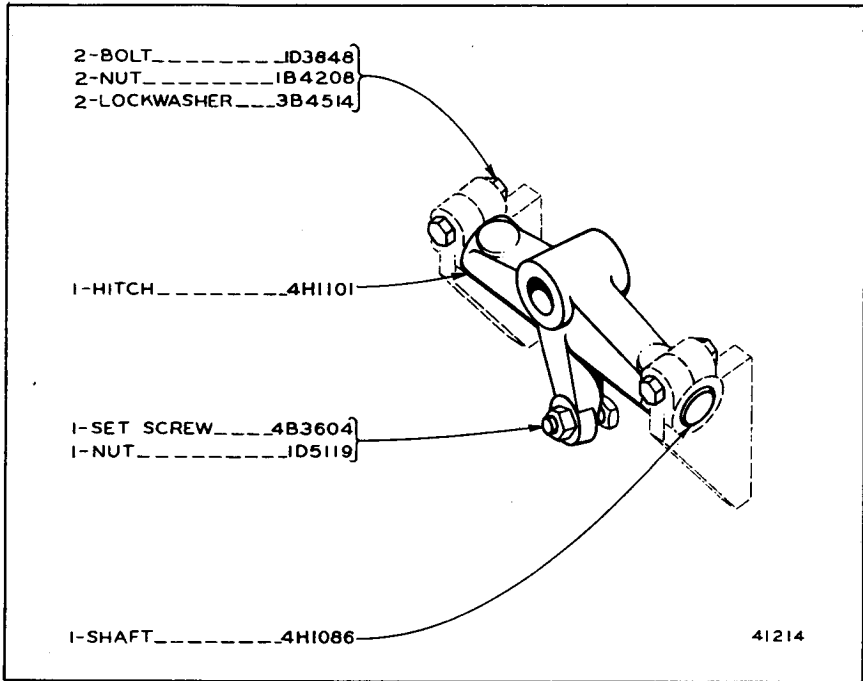

4H2647 SHEAVE HITCH GROUP

For use on D8 Tractors having Serial No. 14A1—Up and 15A1—Up

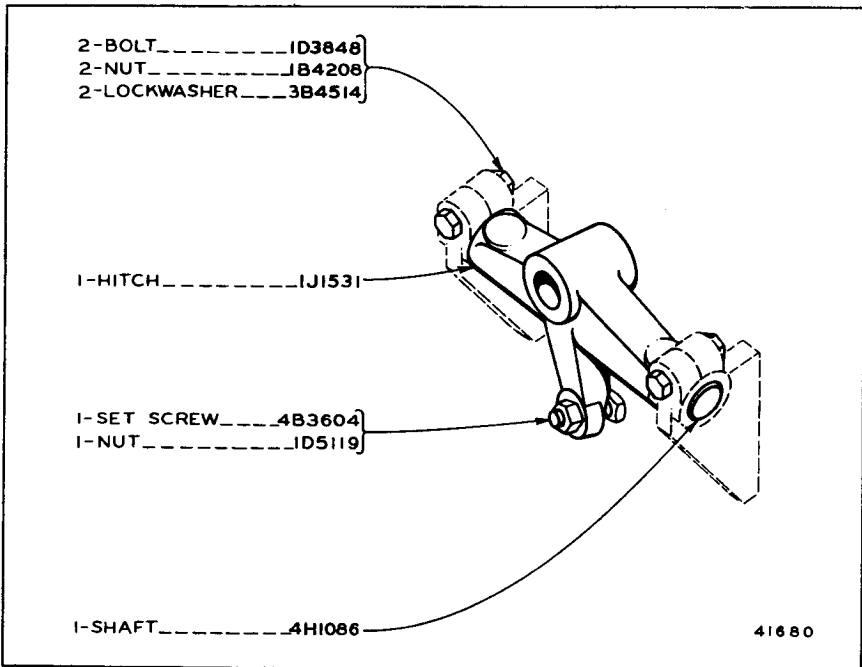

1J1532 SHEAVE HITCH GROUP

Effective with No. 8S Bulldozer Serial No. 44C1193 and No. 8U Bulldozer Serial No. 11C5982
 For use on D8 Tractors having Serial No. 2U9662 to 2U23537 and 13A1 to 13A3703 inclusive

ALWAYS GIVE SERIAL NUMBER WHEN ORDERING PARTS

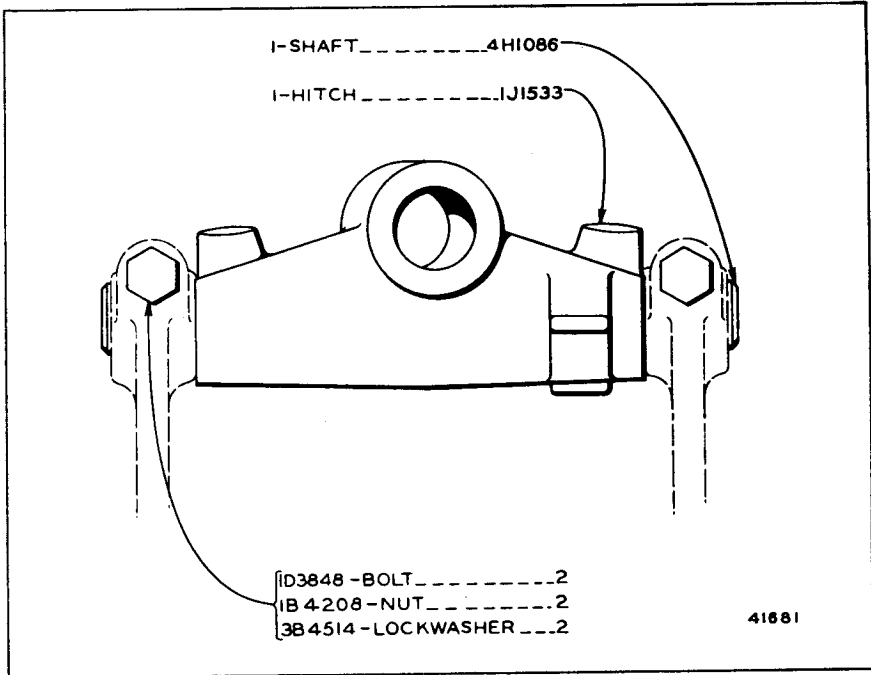
**IJ1534 SHEAVE HITCH GROUP**

Effective with No. 8A Bulldozer Serial No. 18C10992
and No. 85 Bulldozer Serial No. 44C1193.

For use on D8 Tractors having Serial No. 5E8001 to 5E8035, 1H1 to 1H9999, 8R1 to 8R9999,
2U1 to 2U23537 and 13A1 to 13A3703 inclusive

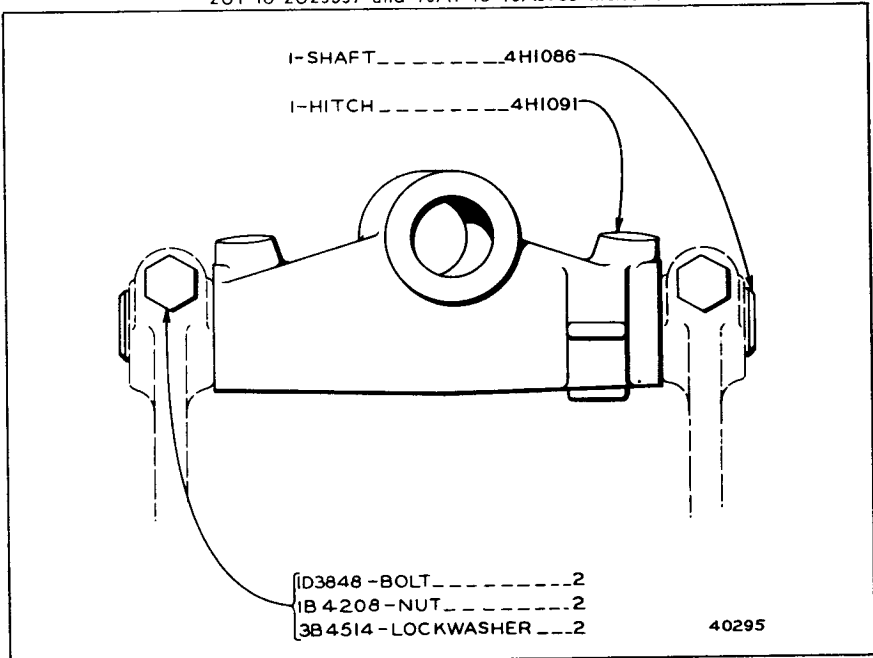
**4H1209 SHEAVE HITCH GROUP**

Effective with No. 8A Bulldozer Serial No. 18C10992

ONLY "CATERPILLAR" PARTS GIVE "CATERPILLAR" PERFORMANCE

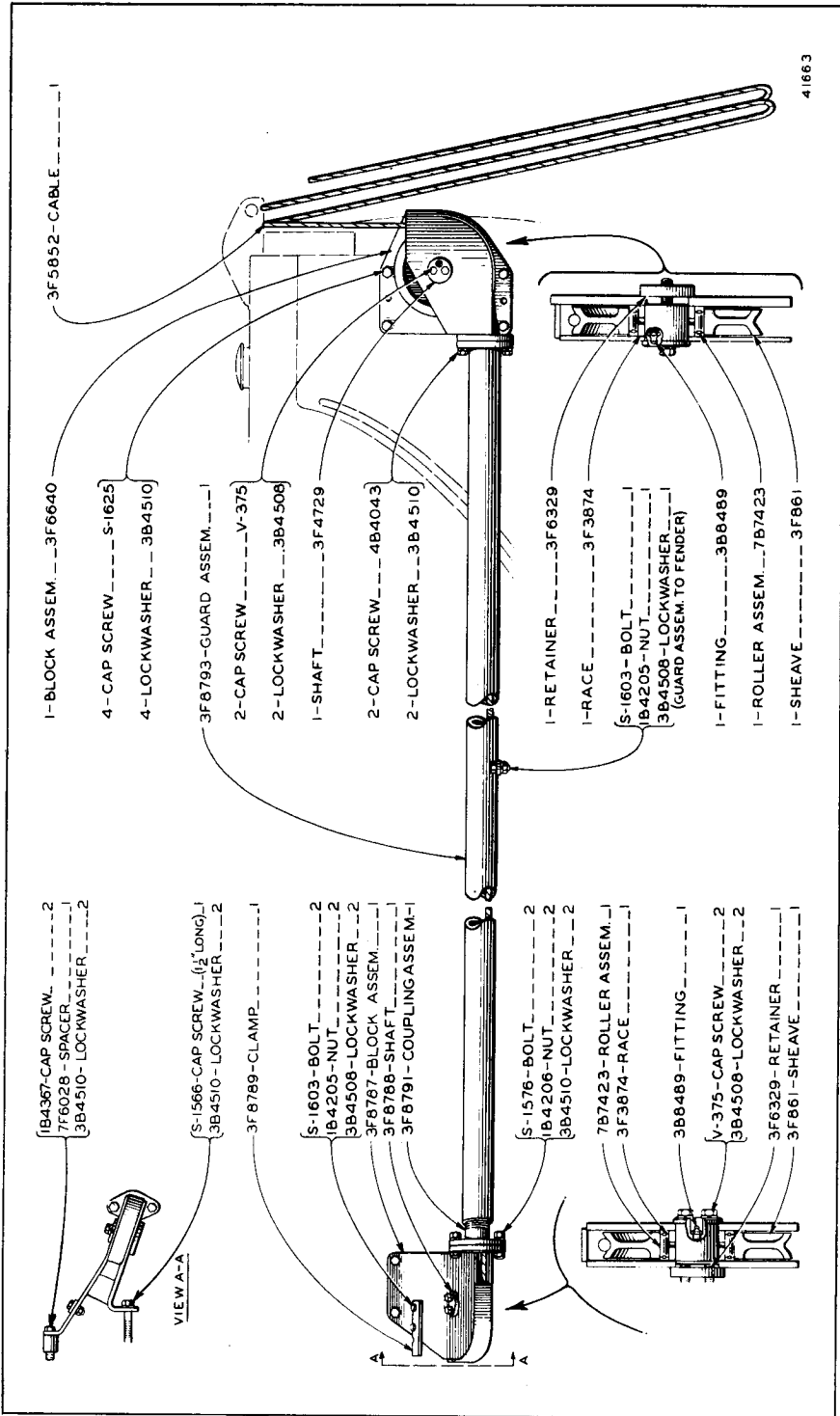

3F280 CABLE AND GUARD GROUP

For use with No. 25 Cable Control
 For use on D8 Tractors having Serial No. 5E8001 to 5E8035, 1H1 to 1H9999, 8R1 to 8R9999 and 2U1 to 2U23537 inclusive

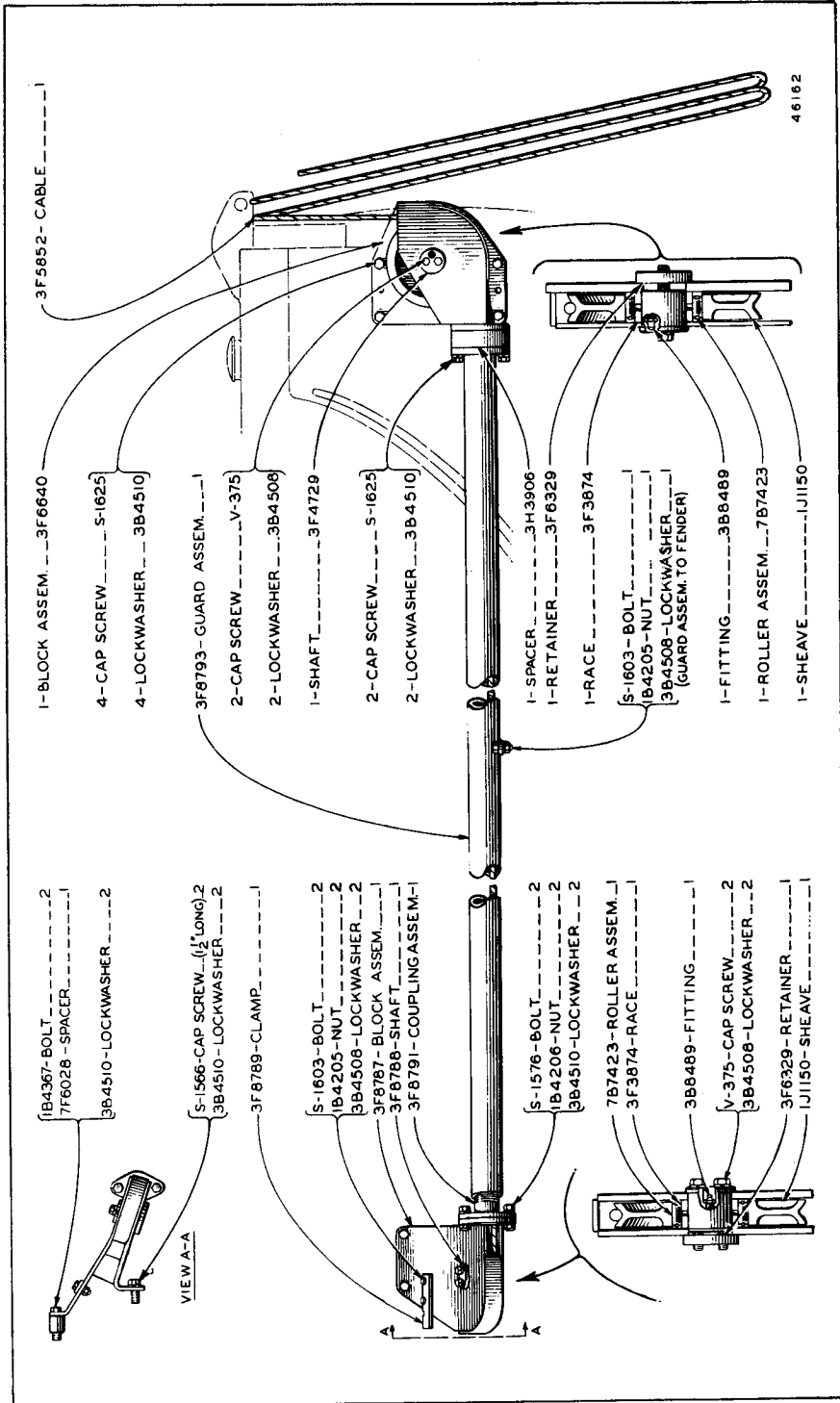

3H2660 CABLE AND GUARD GROUP

For use with No. 25 Cable Control
For use on D8 Tractors having Serial No. 13A1 to 13A3703 inclusive

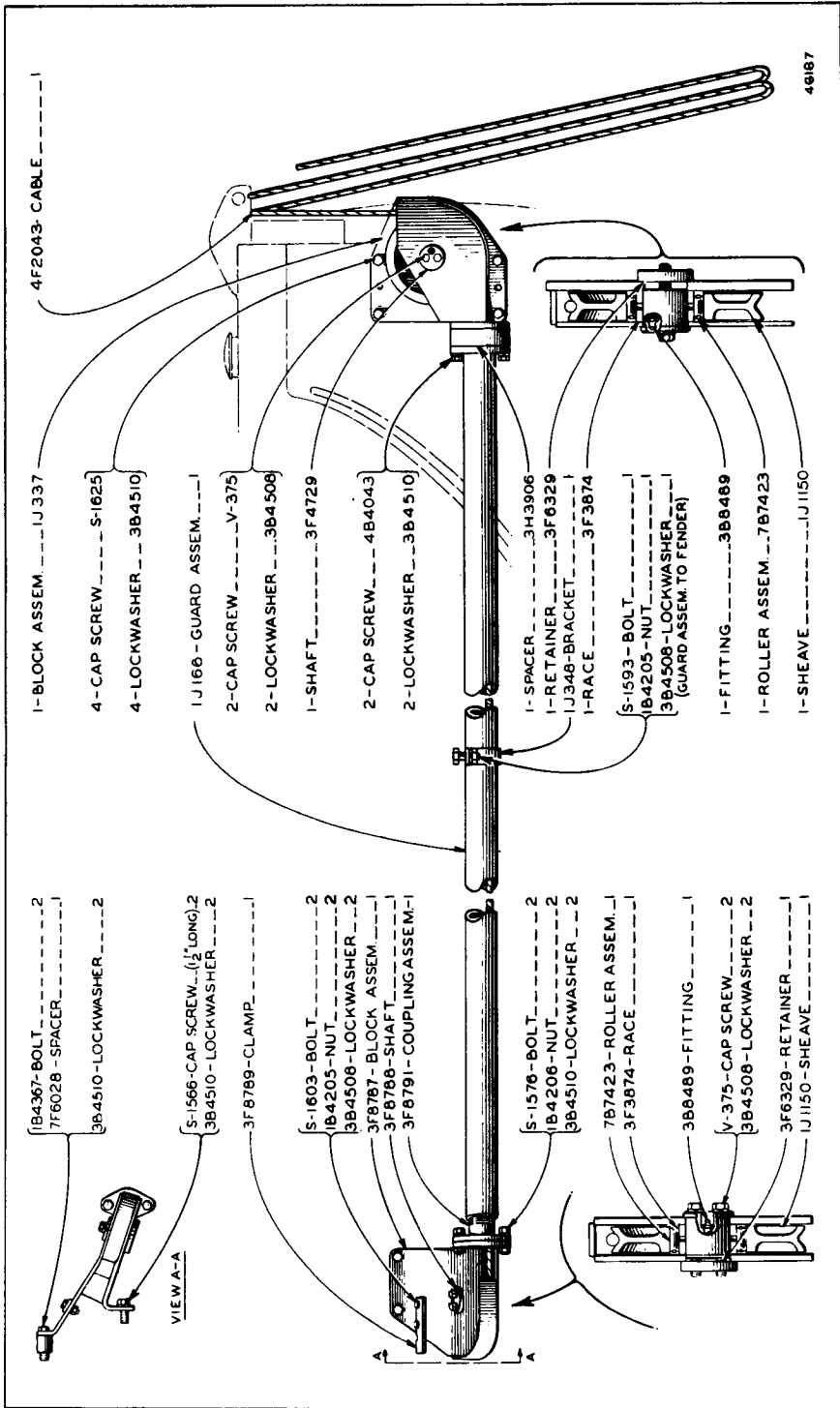

IJ168 CABLE AND GUARD GROUP—First Type
 For use with No. 25 Cable Control
 For use on D8 Tractors having Serial No. 14A1—Up

ALWAYS GIVE SERIAL NUMBER WHEN ORDERING PARTS

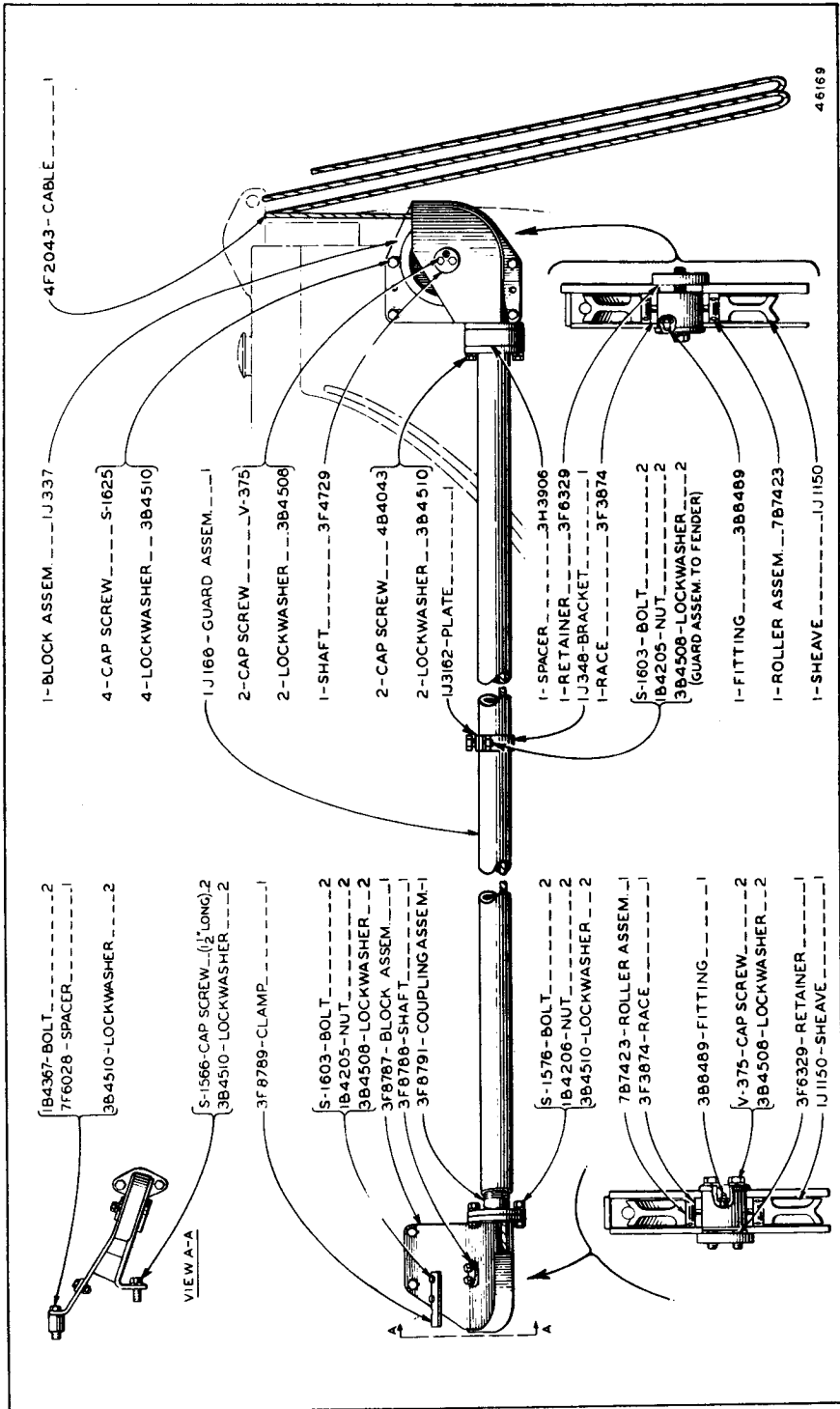

IJ168 CABLE AND GUARD GROUP—Second Type
 For use with No. 25 Cable Control
 For use on D8 Tractors having Serial No. 14A1—Up

ONLY "CATERPILLAR" PARTS GIVE "CATERPILLAR" PERFORMANCE

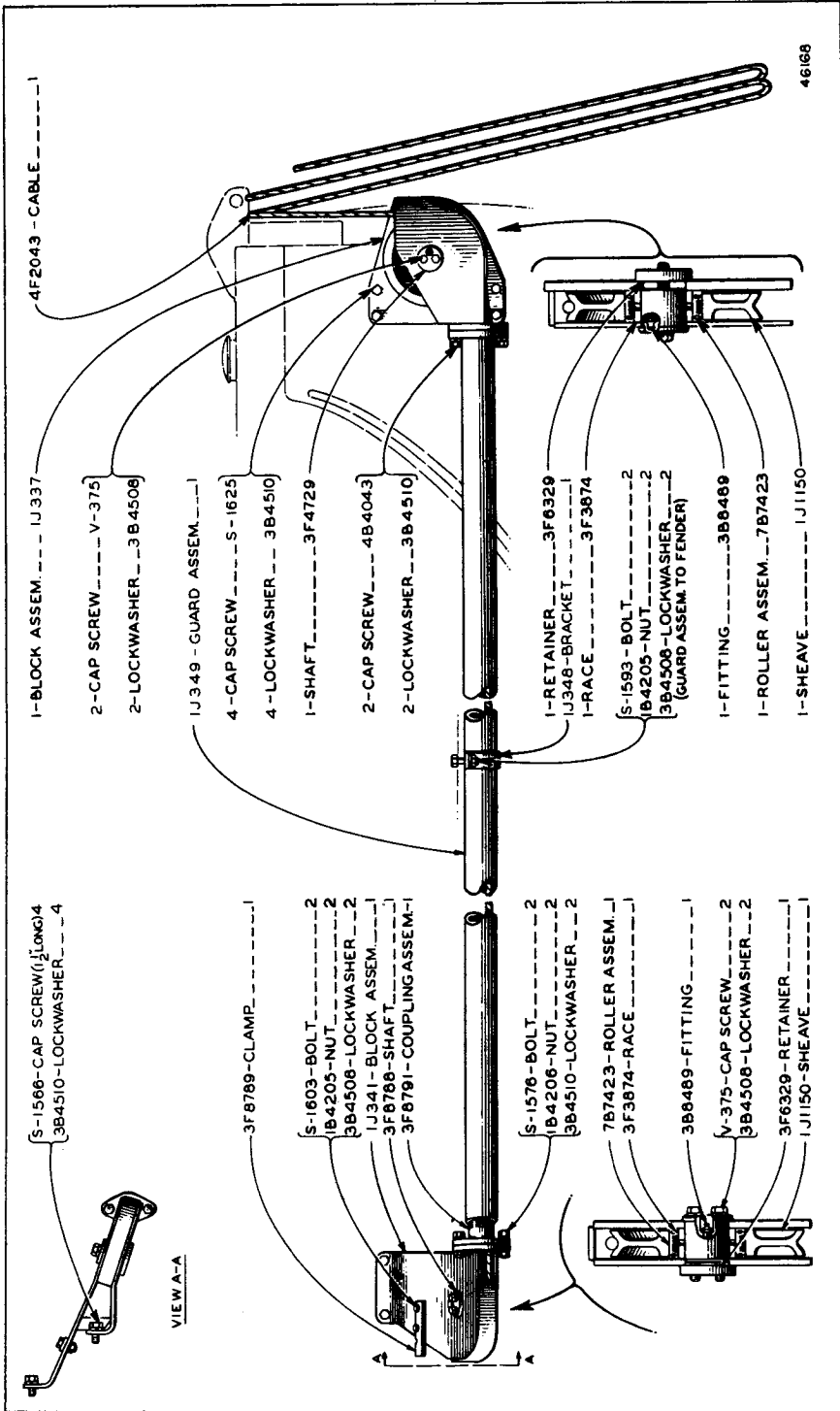

IJ358 CABLE AND GUARD GROUP—First Type
 For use with No. 29 Cable Control
 For use on D8 Tractors having Serial No. 15A1—Up

ALWAYS GIVE SERIAL NUMBER WHEN ORDERING PARTS

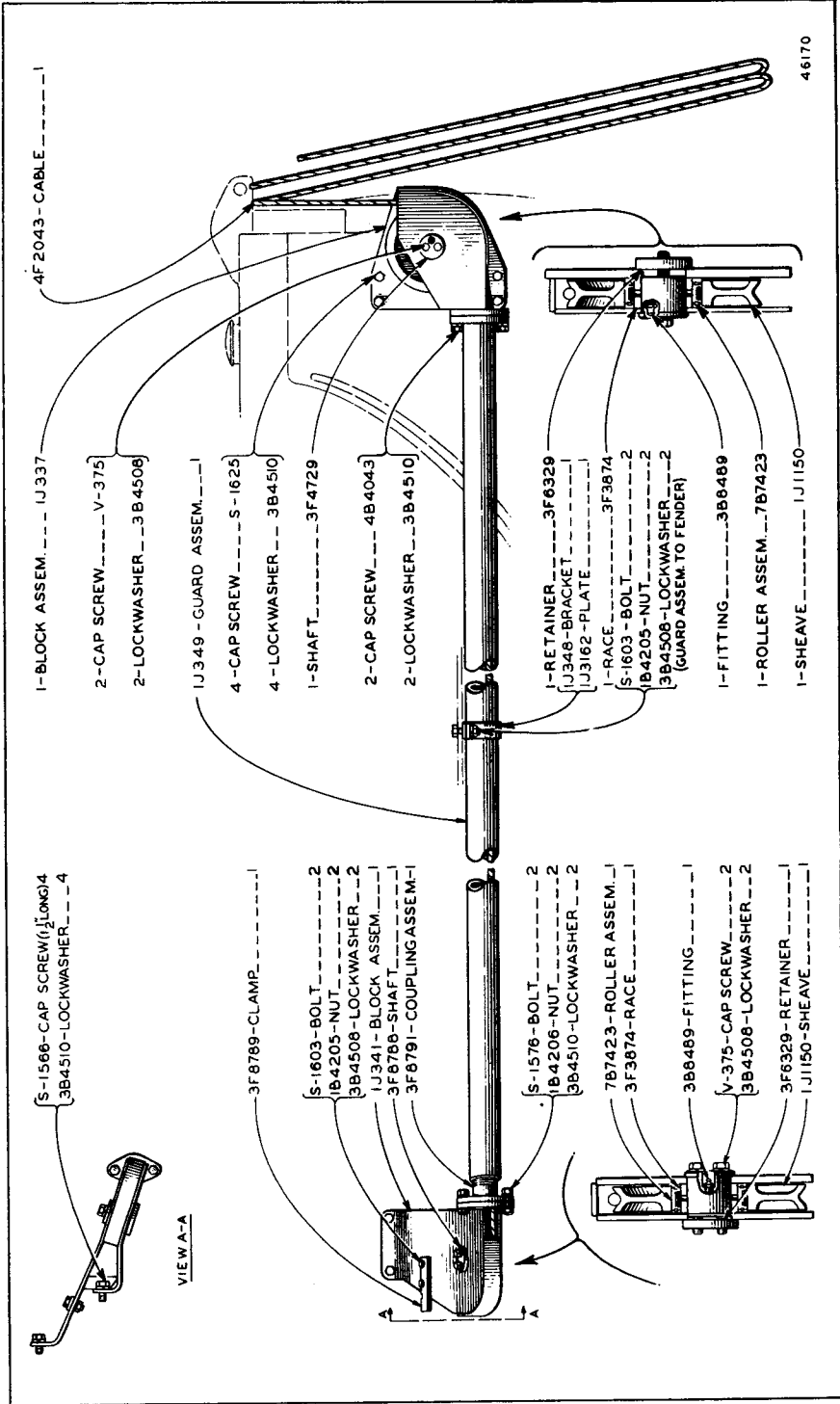

IJ358 CABLE AND GUARD GROUP—Second Type

For use with No. 29 Cable Control
For use on D8 Tractors having Serial No. 15A1—Up

ONLY "CATERPILLAR" PARTS GIVE "CATERPILLAR" PERFORMANCE

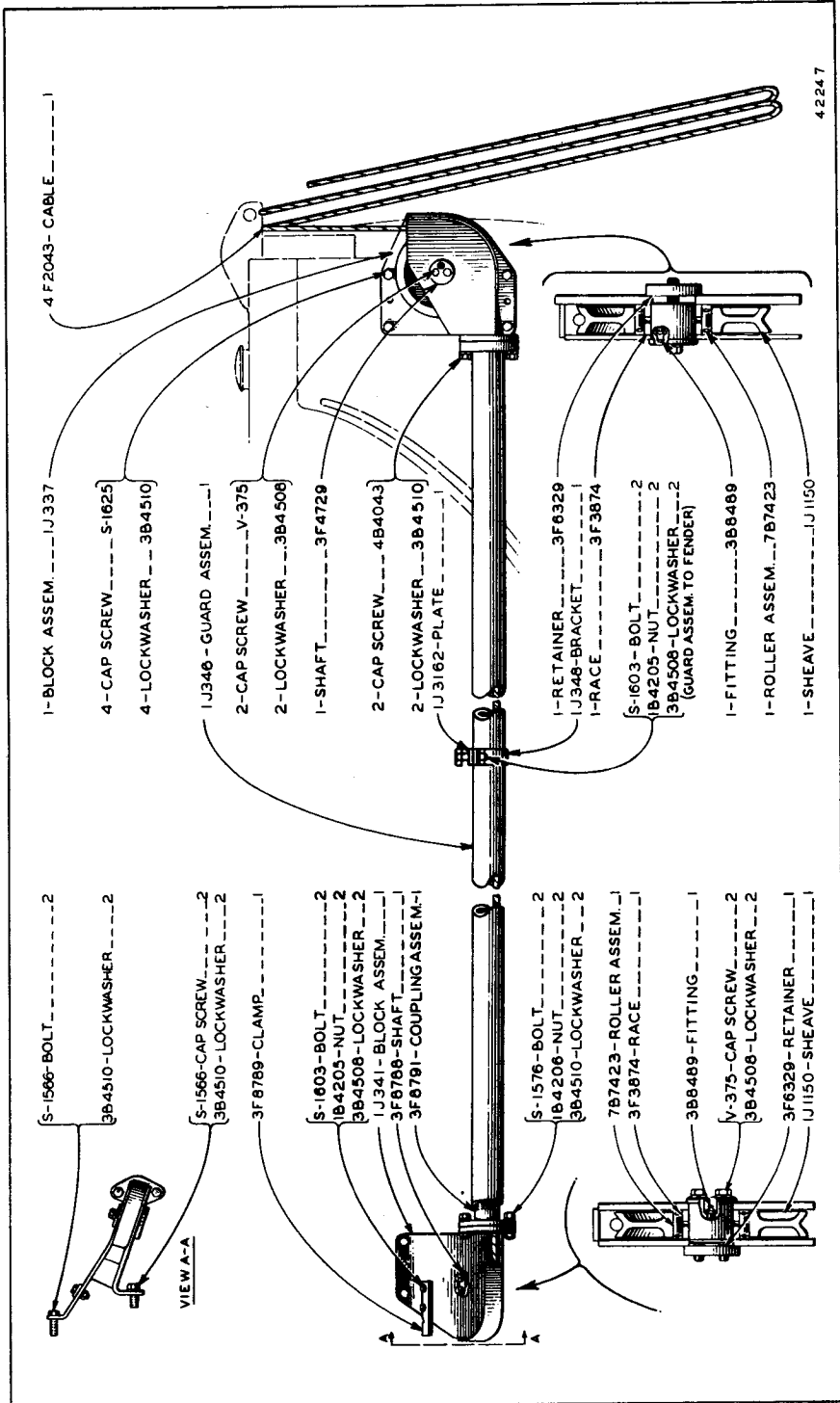

IJ361 CABLE AND GUARD GROUP
 For use with No. 29 Cable Control
 For use on D8 Tractors having Serial No. 14A—Up

ALWAYS GIVE SERIAL NUMBER WHEN ORDERING PARTS

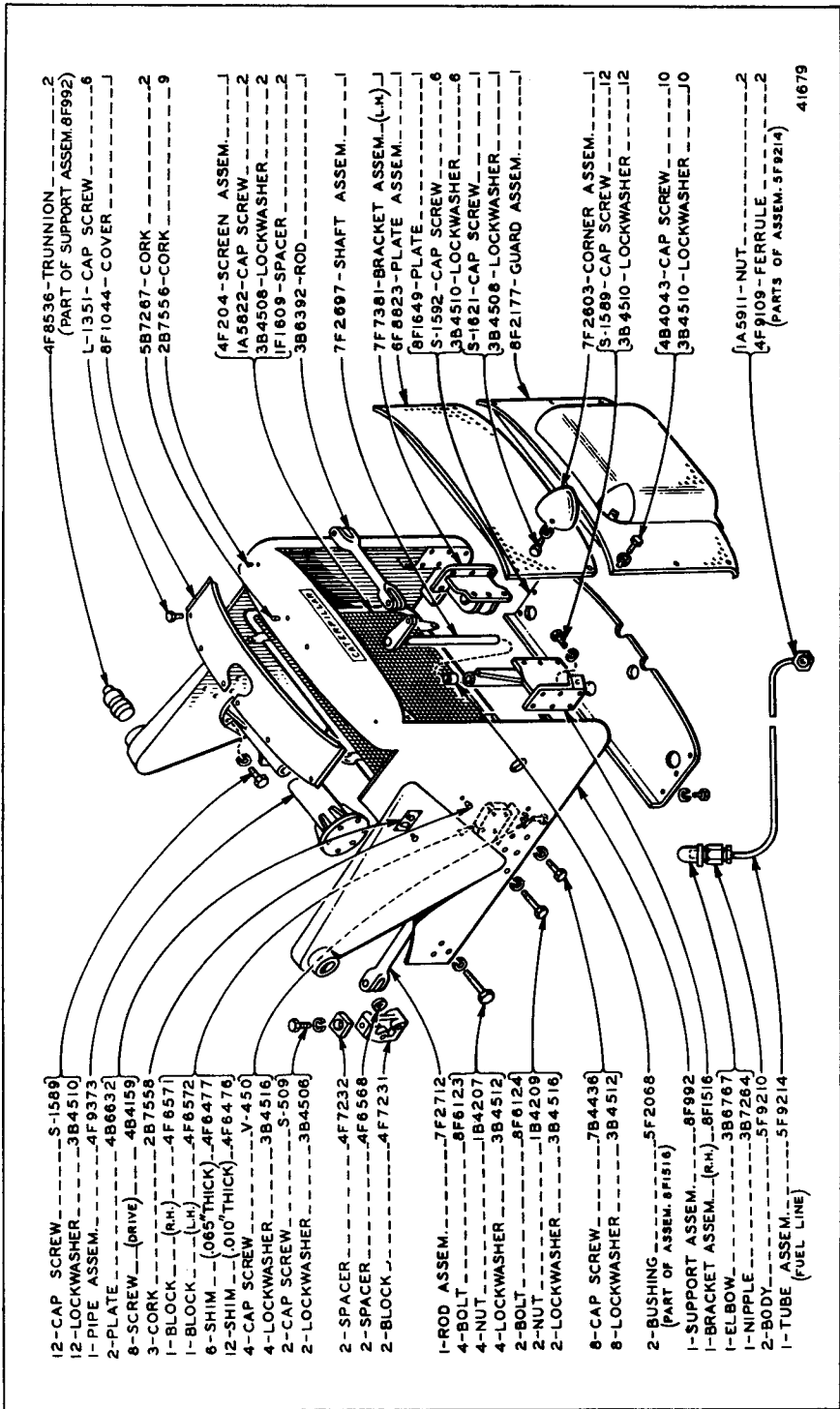

- | | |
|-------------------------------------|---|
| 12--CAP SCREW.....S-1589 | 4F8536--TRUNNION.....2 |
| 12--LOCKWASHER.....3B4510 | (PART OF SUPPORT ASSEM.8F992) |
| 1--PIPE ASSEM.....4F9373 | L-1351--CAP SCREW.....6 |
| 2--PLATE.....4B8632 | 8F1044--COVER.....2 |
| 8--SCREW (drive).....4B4159 | 5B7267--CORK.....2 |
| 3--CORK.....2B7558 | 2B7556--CORK.....9 |
| 1--BLOCK (R.H.).....4F6571 | |
| 1--BLOCK (L.H.).....4F8572 | |
| 6--SHIM (.065"THICK).....4F6477 | |
| 12--SHIM (.010"THICK).....4F6476 | |
| 4--CAP SCREW.....V-450 | |
| 4--LOCKWASHER.....3B4516 | |
| 2--CAP SCREW.....S-509 | |
| 2--LOCKWASHER.....3B4506 | |
| 2--SPACER.....4F7232 | |
| 2--SPACER.....4F6568 | |
| 2--BLOCK.....4F7231 | |
| 1--ROD ASSEM.....7F2712 | |
| 4--BOLT.....8F6123 | |
| 4--NUT.....1B4207 | |
| 4--LOCKWASHER.....3B4512 | |
| 2--BOLT.....8F6124 | |
| 2--NUT.....1B4209 | |
| 2--LOCKWASHER.....3B4516 | |
| 8--CAP SCREW.....7B4436 | |
| 8--LOCKWASHER.....3B4512 | |
| 2--RUSHING (PART OF ASSEM.8F1516) | |
| 1--SUPPORT ASSEM.....8F992 | |
| 1--BRACKET ASSEM. (R.H.).....8F1516 | |
| 1--EL.BOW.....3B6767 | |
| 1--NIPPLE.....3B7264 | |
| 2--BODY ASSEM.....5F9210 | |
| 1--TUBE (FUEL LINE).....5F9214 | |
| | 4F204--SCREEN ASSEM.....2 |
| | 1A5822--CAP SCREW.....2 |
| | 3B4508--LOCKWASHER.....2 |
| | 1F1609--SPACER.....2 |
| | 3B6392--ROD.....2 |
| | 7F2697--SHAFT ASSEM.....2 |
| | 7F7381--BRACKET ASSEM. (L.H.).....2 |
| | 6F8623--PLATE ASSEM.....2 |
| | 8F1649--PLATE.....2 |
| | S-1592--CAP SCREW.....6 |
| | 3B4510--LOCKWASHER.....6 |
| | S-1621--CAP SCREW.....2 |
| | 3B4508--LOCKWASHER.....2 |
| | 8F2177--GUARD ASSEM.....2 |
| | 7F2603--CORNER ASSEM.....2 |
| | S-1589--CAP SCREW.....12 |
| | 3B4510--LOCKWASHER.....12 |
| | 4B4043--CAP SCREW.....10 |
| | 3B4510--LOCKWASHER.....10 |
| | 1A5811--NUT.....2 |
| | 4F9109--FERRULE (PARTS OF ASSEM.5F9214) |
| | 41679 |

8F1047 CYLINDER SUPPORT GROUP

Effective with No. 8A Bulldozer Serial No. 18C10992 and No. 8S Bulldozer Serial No. 44C1193
 For use on D8 Tractors having Serial No. 1H2409 to 1H9999, 8R1 to 8R9999 and 2U1 to 2U9661 inclusive

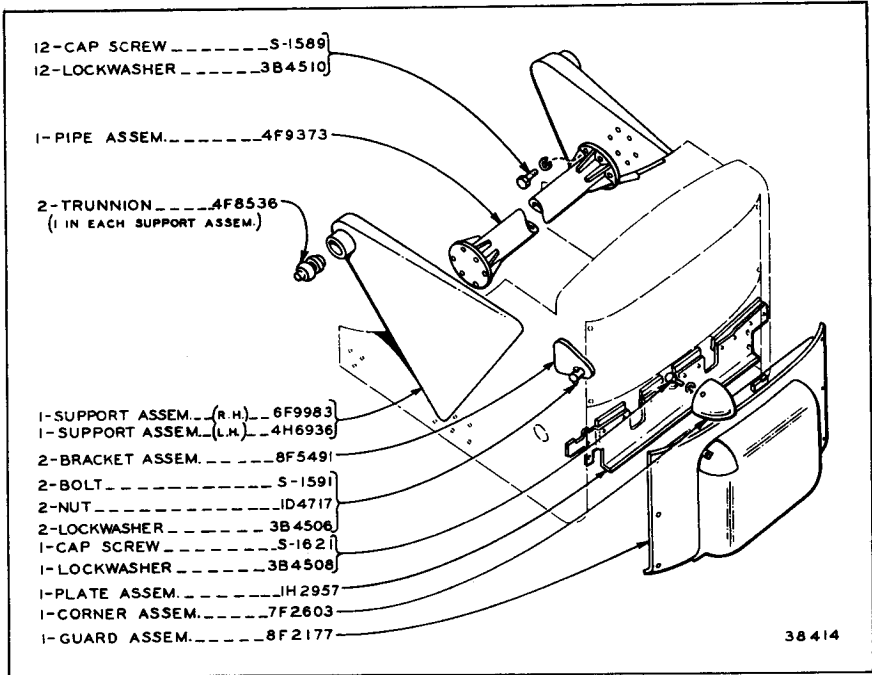

4H6939 CYLINDER BRACKET GROUP

Effective with No. 8A Bulldozer Serial No. 18C10992 and No. 8S Bulldozer Serial No. 44C1193. For use on D8 Tractors having Serial No. 2U9662 to 2U23537 and 13A1 to 13A3703 inclusive and Six Roller Track Roller Frame

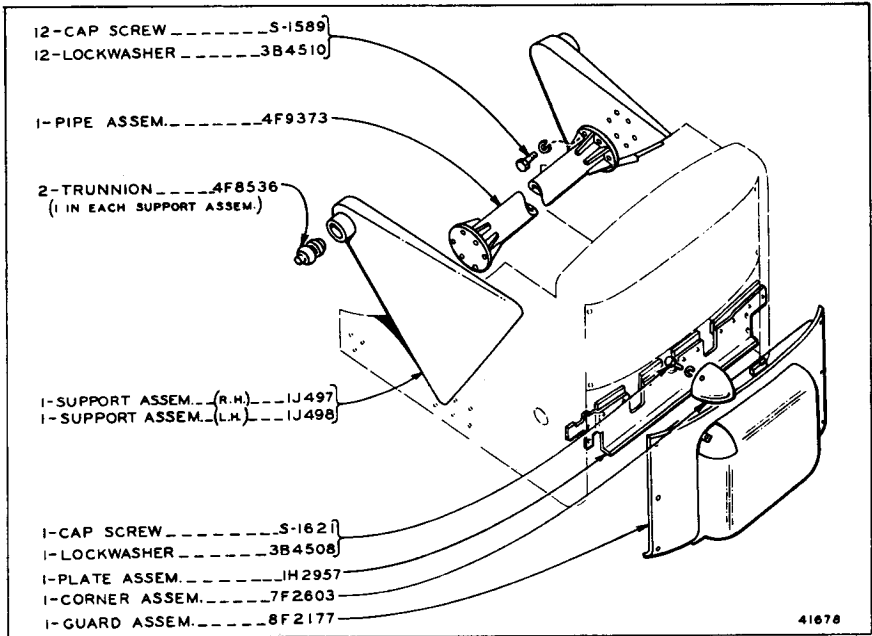

1J483 CYLINDER BRACKET GROUP

Effective with No. 8A Bulldozer Serial No. 18C10992 and No. 8S Bulldozer Serial No. 44C1193. For use on D8 Tractors having Serial No. 13A1 to 13A3703 inclusive and Seven Roller Track Roller Frame

ALWAYS GIVE SERIAL NUMBER WHEN ORDERING PARTS

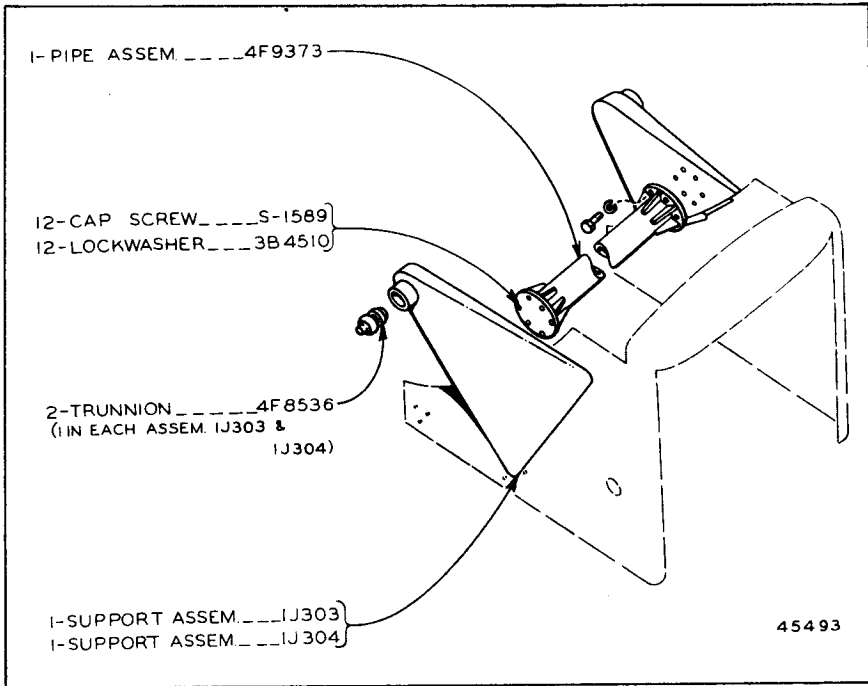
**IJ363 CYLINDER BRACKET GROUP—First Type**

Effective with No. 8A Bulldozer Serial No. 18C10992 and No. 8S Bulldozer Serial No. 44C1193. For use on D8 Tractors having Serial No. 14A1—Up and 15A1—Up

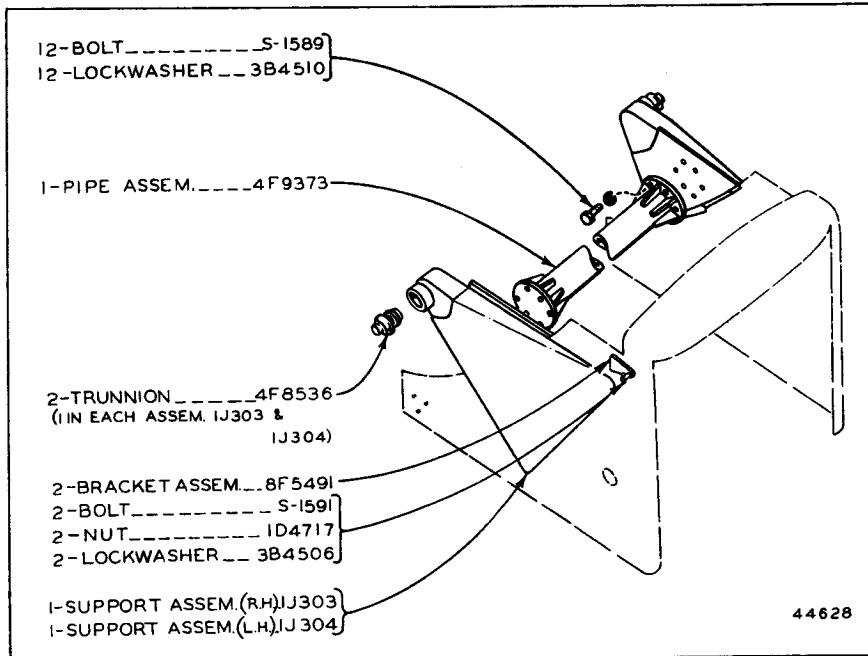
**IJ363 CYLINDER BRACKET GROUP—Second Type**

Effective with No. 8A Bulldozer Serial No. 18C10992 and No. 8S Bulldozer Serial No. 44C1193. For use on D8 Tractors having Serial No. 14A1—Up and 15A1—Up

ONLY "CATERPILLAR" PARTS GIVE "CATERPILLAR" PERFORMANCE

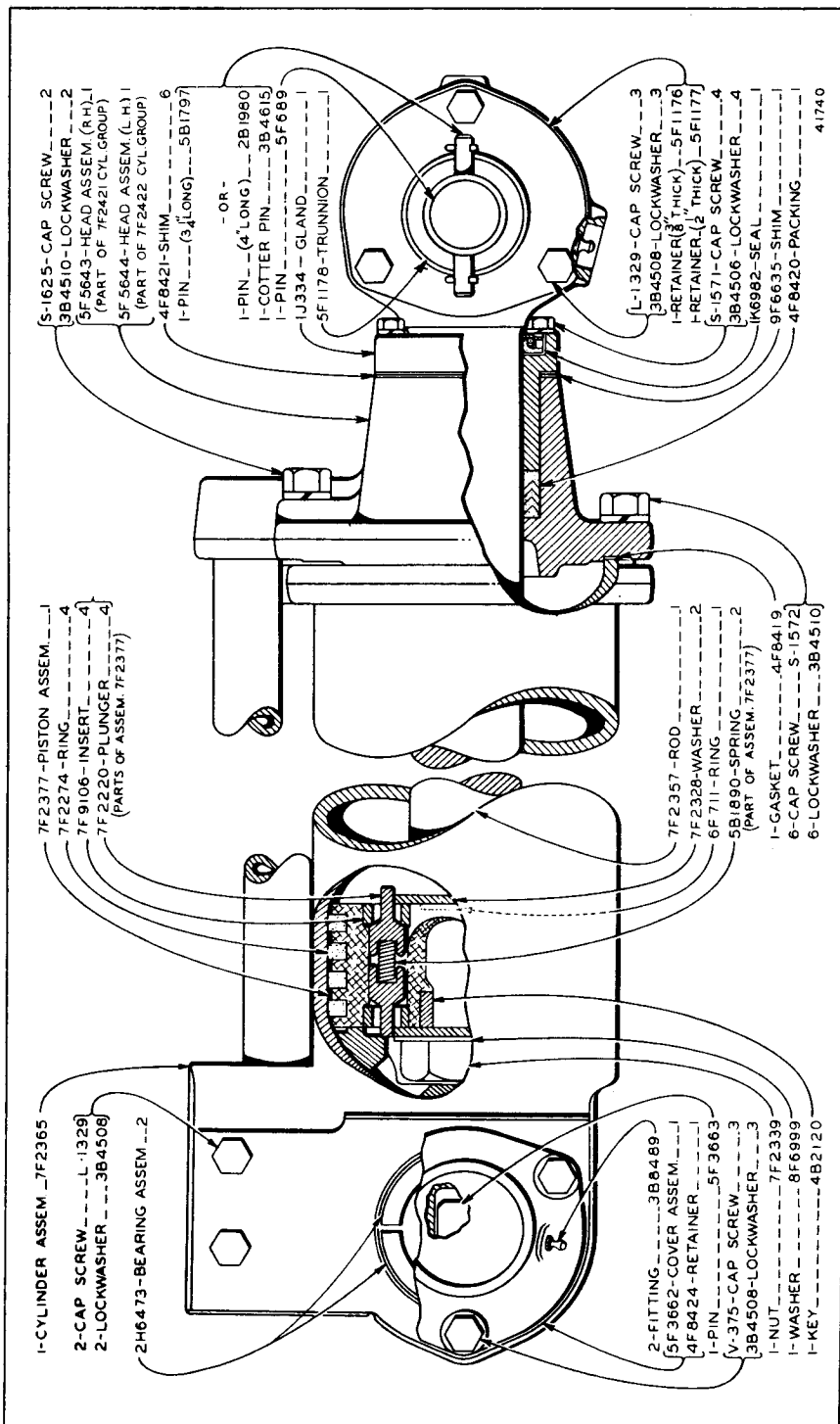

**7F2421 HYDRAULIC CYLINDER GROUP—R. H.
7F2422 HYDRAULIC CYLINDER GROUP—L. H.**

Effective with No. 8A Bulldozer Serial No. 18C10992 and No. 85 Bulldozer Serial No. 44C1193
For use on D8 Tractors having Serial No. 1H2409 to 1H9999, 8R1 to 8R9999 and 2U1 to 2U23537 inclusive

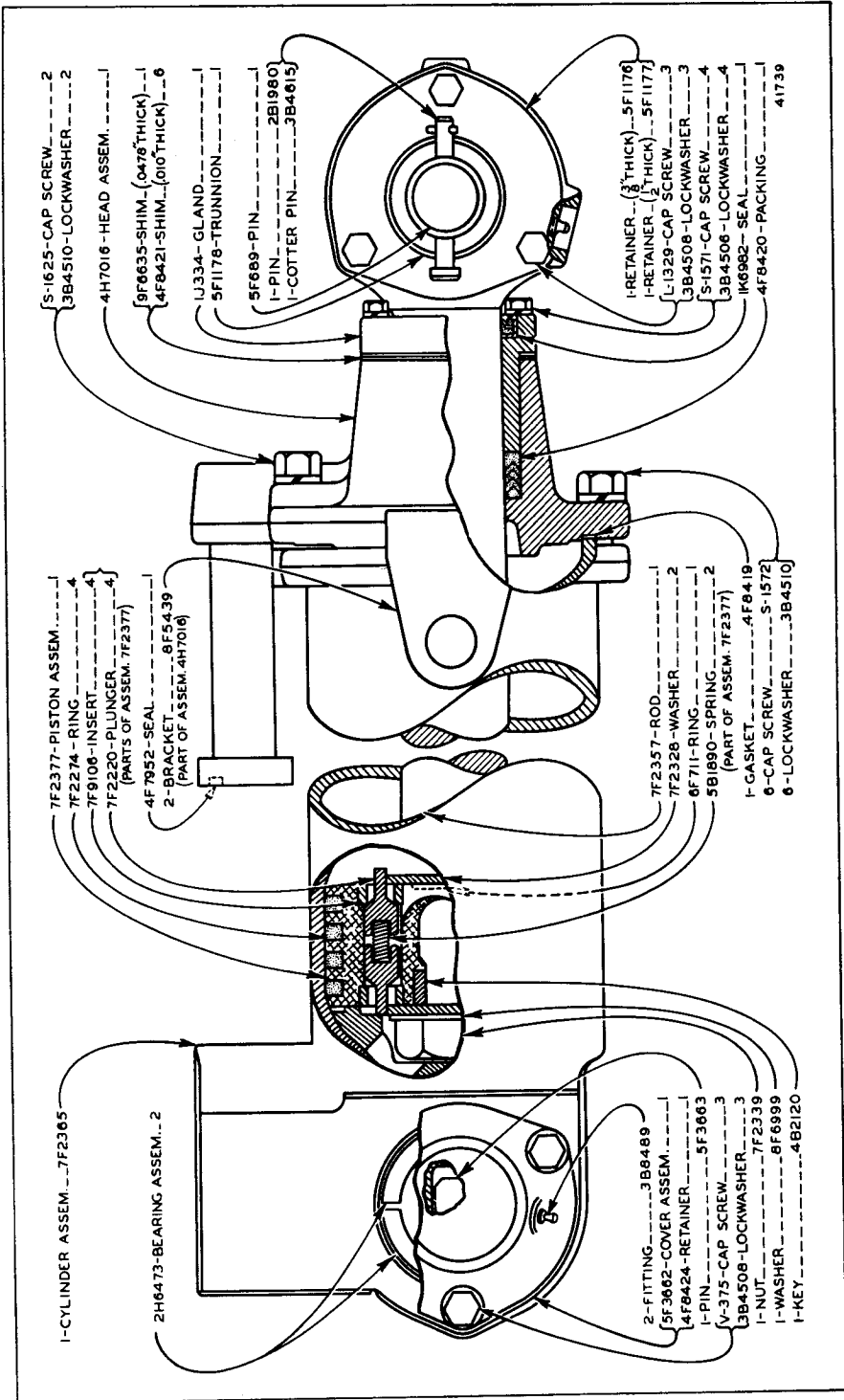

4H6961 HYDRAULIC CYLINDER GROUP

Effective with No. 8A Bulldozer Serial No. 18C10992 and No. 8S Bulldozer Serial No. 44C1193
 For use on D8 Tractors having Serial No. 13A1 to 13A3703, 14A1—Up and 15A1—Up

ONLY "CATERPILLAR" PARTS GIVE "CATERPILLAR" PERFORMANCE

PARTS SERVICE — When you need replacement parts for your Caterpillar machines, you need only call on your CAT Dealer. In a short time, your order is filled and ready so that you can get your machine back on the job quickly where it can continue earning profits for you.

VENDEMOS REPUESTOS — Cuando usted necesita repuestos para sus máquinas Caterpillar, usted necesita sólo llamar a su Distribuidor Caterpillar. En poco tiempo su orden será atendida y llenada, de forma que usted podrá tener su máquina en trabajo, obteniendo ganancias para usted.

PIECES DE RECHANGE — Si vous avez besoin d'une pièce de rechange pour une machine Caterpillar, adressez-vous à votre concessionnaire CAT. Votre commande sera exécutée rapidement et vous pourrez remettre votre machine en service sans retard. Vous éviterez des interruptions prolongées toujours très onéreuses.

PEÇAS DE SUBSTITUIÇÃO — Se você precisar de peças para as suas máquinas Caterpillar, basta chamar o distribuidor Cat de sua zona. Em pouco tempo seu pedido é atendido e, prontamente, você pode levar sua máquina de volta para o trabalho, para ela continuar a lhe dar lucros.



**SPECIFY GENUINE
CATERPILLAR PARTS**

IJ4036 Hydraulic Tilt Dozer Cylinder Arrangement

For use on D8 Tractors having Serial No. 13A1 to 13A3703 equipped with Seven Roller Track Roller Frames and 14A1—Up and 15A1—Up equipped with Trunnion Group IJ362

Consists of:

- 1 IJ2174 Cylinder GroupPage 37
- 1 IJ3932 Trunnion GroupPage 38

IJ4036 HYDRAULIC TILT DOZER CYLINDER ARRANGEMENT

ALWAYS GIVE SERIAL NUMBER WHEN ORDERING PARTS

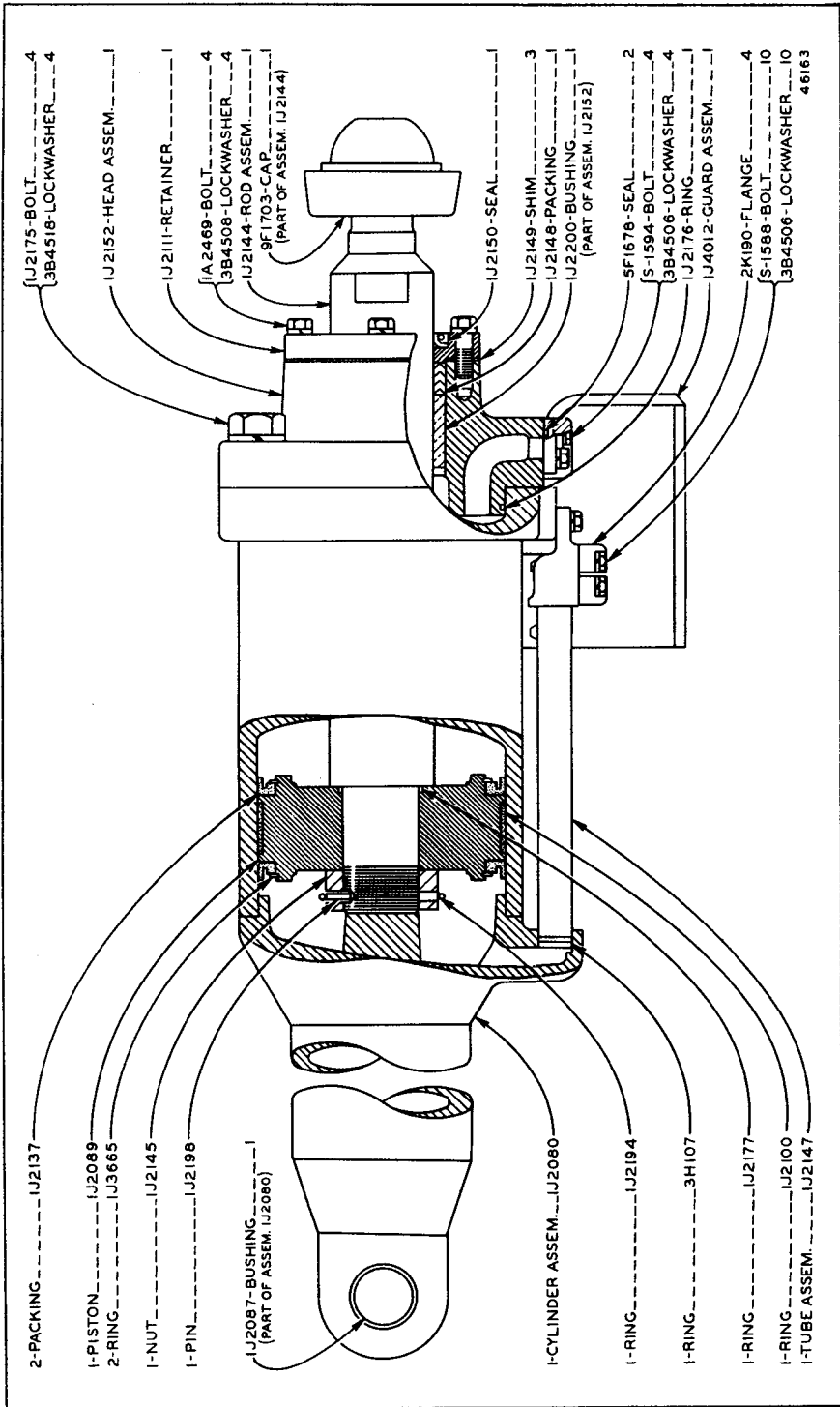

IJ2174 HYDRAULIC TILT DOZER CYLINDER GROUP
 Part of IJ4036 Hydraulic Tilt Dozer Cylinder Arrangement

ONLY "CATERPILLAR" PARTS GIVE "CATERPILLAR" PERFORMANCE

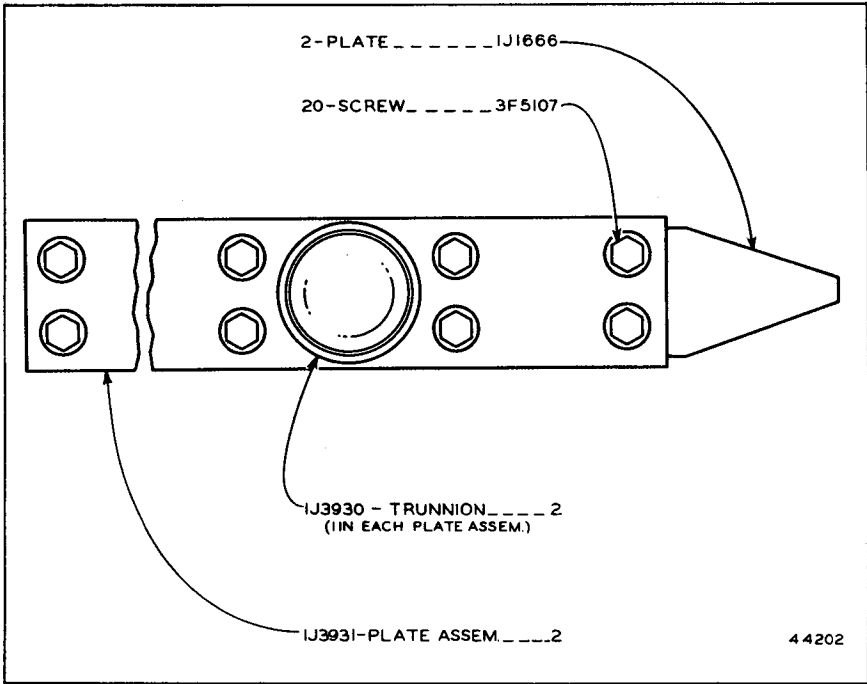

IJ3932 TRUNNION GROUP

Part of IJ4036 Hydraulic Tilt Dozer Cylinder Arrangement listed on Page 36

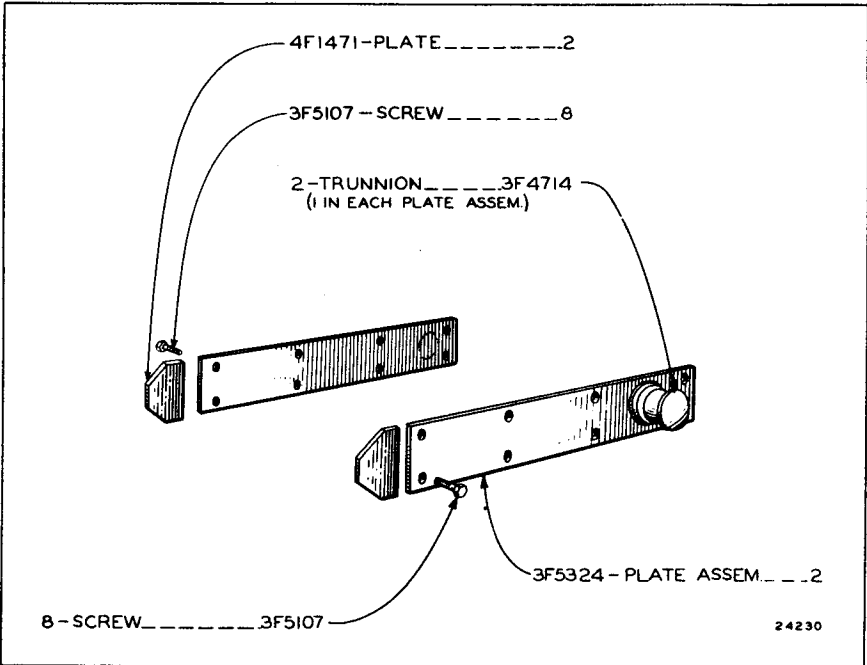

4F6219 TRUNNION GROUP

For use on D8 Tractors having Serial No. 5E8001 to 5E8035, 1H1 to 1H9999, 8R1 to 8R9999 and 2U1 to 2U23537 inclusive

ALWAYS GIVE SERIAL NUMBER WHEN ORDERING PARTS

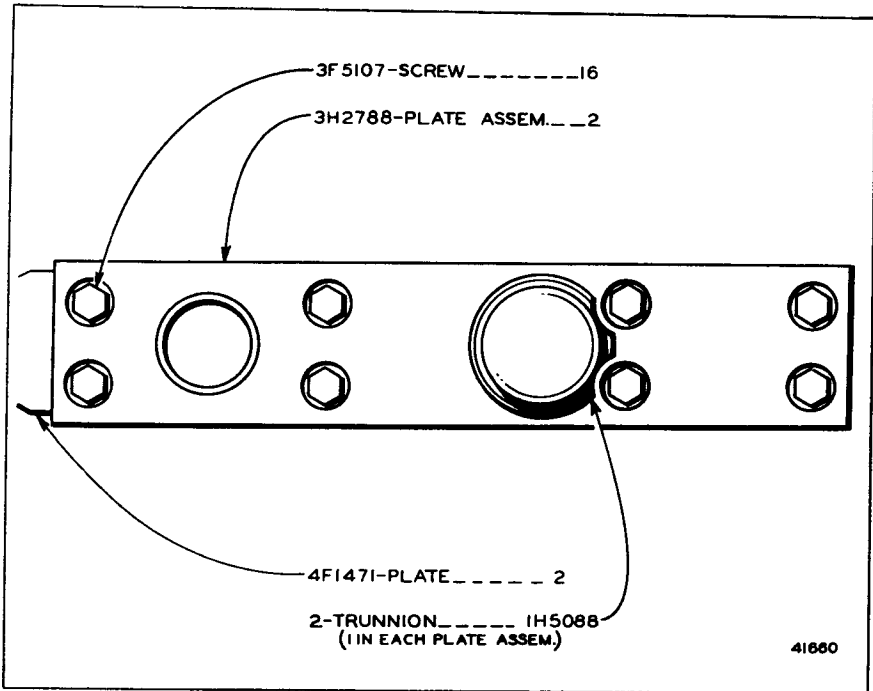

3H2791 TRUNNION GROUP

Effective with No. 8A Bulldozer Serial No. 18C10992 and No. 8S Bulldozer Serial No. 44C1193. For use on D8 Tractors having Serial No. 13A1 to 13A3703 inclusive

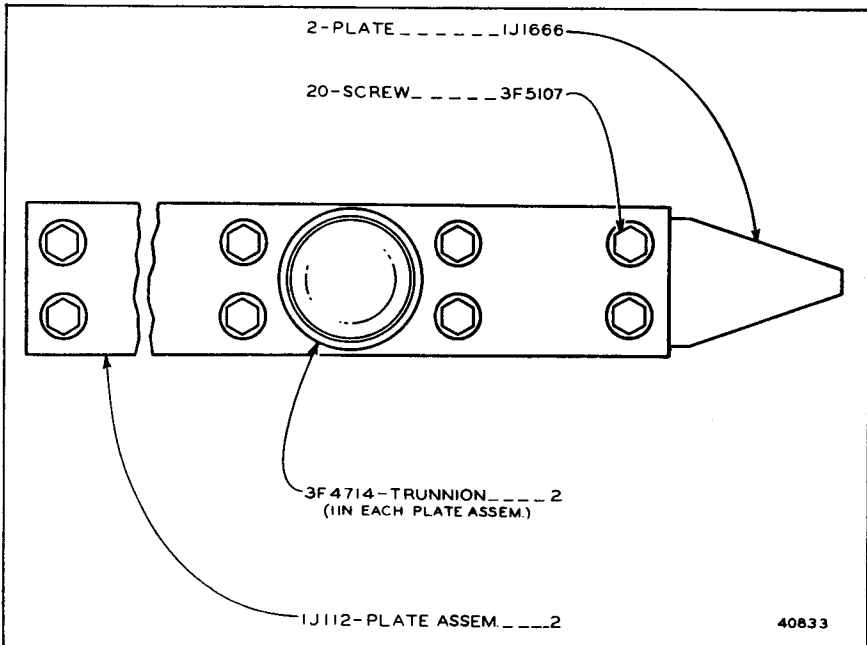

1J362 TRUNNION GROUP

For use on D8 Tractors having Serial No. 13A1 to 13A3703 equipped with Seven Roller Track Roller Frames and 14A1—Up and 15A1—Up. Only separate parts serviced.

When Complete Group is required order 1J3932

ONLY "CATERPILLAR" PARTS GIVE "CATERPILLAR" PERFORMANCE

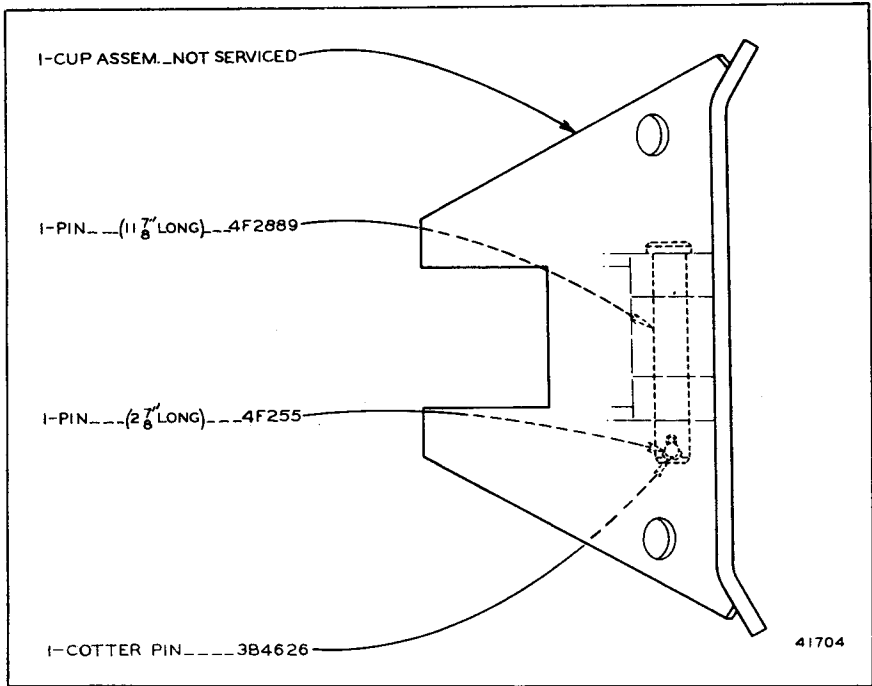

IJ1741 PUSH CUP GROUP

Effective with No. 8A Bulldozer Serial No. 18C10992

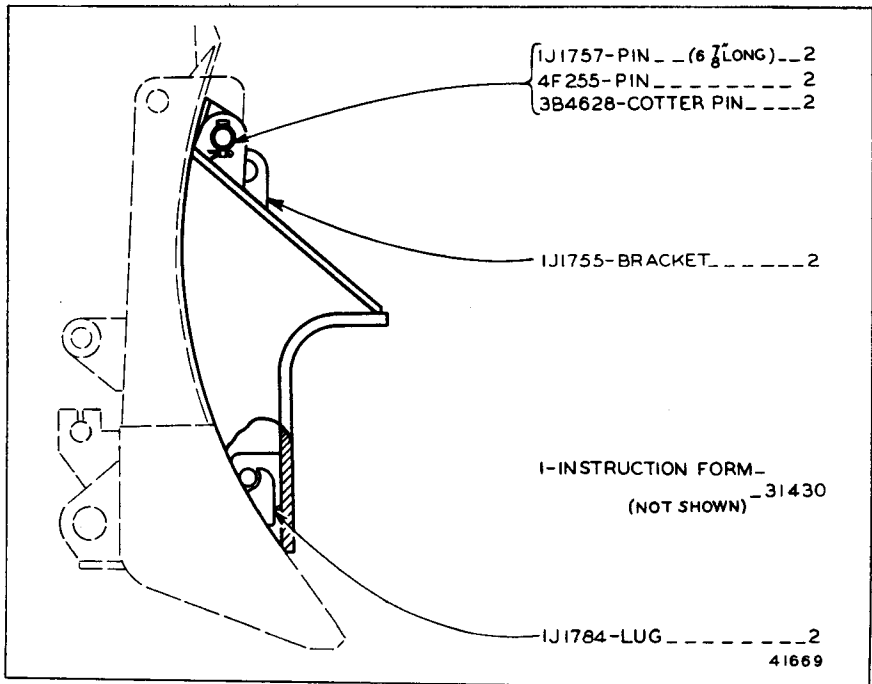

IJ1554 PUSH CUP GROUP

Effective with No. 8S Bulldozer Serial No. 44C1193

ALWAYS GIVE SERIAL NUMBER WHEN ORDERING PARTS

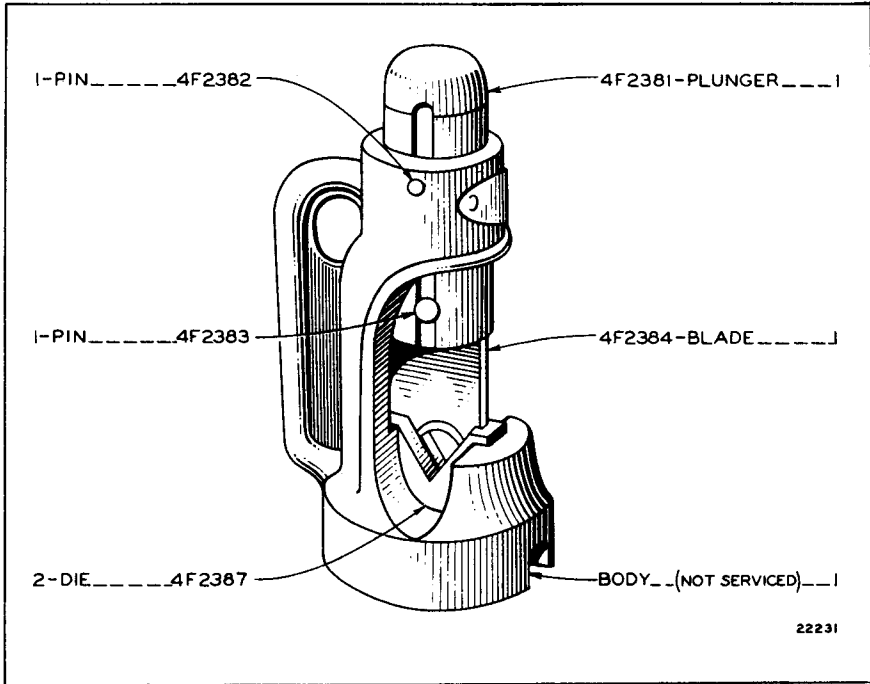

8B7403 CABLE CUTTER

ONLY "CATERPILLAR" PARTS GIVE "CATERPILLAR" PERFORMANCE

MEMORANDA

ALWAYS GIVE SERIAL NUMBER WHEN ORDERING PARTS

MEMORANDA

ONLY "CATERPILLAR" PARTS GIVE "CATERPILLAR" PERFORMANCE

PART NO.	PAGE NO.	PART NO.	PAGE NO.	PART NO.	PAGE NO.	PART NO.	PAGE NO.
		8B7403	41	4F7231	16	8F1045	16
L-1329	19	1D3848	22	4F7232	16	8F1046	16
L-1351	33	1D4593	20	4F7721	19	8F1047	31
L-1648	19	1D4608	13	4F7722	19	8F1516	30
L-2341	20	1D4717	32	4F7952	35	8F1649	16
S-509	16	1D4720	20	4F8419	34	8F1932	17
S-1566	24	1D5119	22	4F8420	34	8F2177	32
S-1571	34	1F1609	16	4F8421	34	8F3005	14
S-1572	34	3F701	21	4F8424	34	8F3006	14
S-1576	24	3F861	24	4F8491	17	8F3556	20
S-1588	37	3F3874	19	4F8536	32	8F3587	20
S-1589	32	3F4611	13	4F9052	10	8F4667	20
S-1591	32	3F4612	14	4F9109	30	8F5439	35
S-1592	16	3F4714	38	4F9373	32	8F5491	32
S-1593	26	3F4729	19	5F483	20	8F6123	16
S-1594	37	3F4854	13	5F689	34	8F6124	16
S-1595	16	3F4897	19	5F1176	34	8F6999	34
S-1600	10	3F4929	8	5F1177	34	8F7272	19
S-1603	24	3F4956	12	5F1178	34	9F1703	13
S-1621	32	3F4971	13	5F1678	37	9F1704	13
S-1625	24	3F4975	13	5F2068	30	9F1706	13
V-375	24	3F5107	38	5F3662	34	9F3721	14
V-450	16	3F5158	19	5F3663	34	9F6635	34
1A2036	18	3F5242	10	5F4434	19	9F6975	14
1A2469	37	3F5290	10	5F4440	19	9F6981	14
1A3103	13	3F5324	38	5F4441	19	1H2135	14
1A5822	16	3F5567	10	5F4442	19	1H2957	32
1A5911	30	3F5597	17	5F5340	13	1H5088	39
1A8063	13	3F5709	10	5F5643	34	2H6473	34
2A1538	10	3F6149	8	5F5644	34	3H107	37
1B4203	17	3F6151	9	5F7596	13	3H2660	25
1B4205	24	3F6154	10	5F7597	13	3H2788	39
1B4206	10	3F6157	10	5F7598	13	3H2791	39
1B4207	13	3F6185	10	5F7985	13	3H2976	18
1B4208	22	3F6222	10	5F7993	13	3H2977	18
1B4209	16	3F6329	19	5F7994	13	3H2978	18
1B4331	8	3F6640	24	5F9210	30	3H3728	10
1B4367	24	3F8787	24	5F9214	30	3H3836	19
2B119	19	3F8788	24	6F711	34	3H3837	19
2B286	10	3F8789	24	6F1700	13	3H3906	25
2B1980	34	3F8791	24	6F2904	9	3H7221	20
2B7556	16	3F8793	24	6F2905	9	3H7224	9
2B7557	16	3F9280	24	6F2981	13	4H1085	20
2B7558	30	3F9384	8	6F2982	13	4H1086	22
3B4506	32	3F9401	19	6F3908	13	4H1087	20
3B4508	32	3F9452	19	6F7024	19	4H1091	23
3B4510	32	4F138	14	6F7031	17	4H1092	20
3B4512	10	4F204	16	6F8823	16	4H1093	20
3B4514	22	4F253	14	6F8825	16	4H1094	20
3B4516	9	4F255	40	6F8925	18	4H1095	20
3B4518	37	4F1121	8	6F9019	18	4H1096	20
3B4615	34	4F1204	9	6F9042	18	4H1097	20
3B4626	40	4F1251	10	6F9323	16	4H1101	22
3B4628	40	4F1252	10	6F9451	17	4H1126	12
3B4643	19	4F1274	10	6F9452	17	4H1209	23
3B5328	10	4F1286	10	6F9832	16	4H2647	22
3B6392	30	4F1294	10	6F9983	32	4H6054	12
3B6767	30	4F1471	38	7F2220	34	4H6055	12
3B7264	30	4F2043	29	7F2274	34	4H6358	8
3B8489	10	4F2152	9	7F2328	34	4H6936	32
4B1254	12	4F2381	41	7F2339	34	4H6939	32
4B2120	34	4F2382	41	7F2357	34	4H6961	35
4B3604	22	4F2384	41	7F2365	34	4H7016	35
4B4043	16	4F2387	41	7F2377	34	1J2	12
4B4159	16	4F2444	20	7F2421	34	1J12	8
4B6632	16	4F2445	20	7F2422	34	1J18	14
5B1797	34	4F2889	40	7F2603	32	1J112	39
5B1890	34	4F6219	38	7F2697	30	1J166	26
5B3097	10	4F6476	16	7F2712	30	1J168	26
5B5473	9	4F6477	16	7F4724	10	1J198	18
5B7267	30	4F6568	16	7F6028	24	1J199	18
6B8147	16	4F6571	16	7F7381	30	1J303	33
7B3235	19	4F6572	16	7F9106	34	1J304	33
7B4436	16	4F6889	12	8F992	30	1J331	18
7B7423	19	4F6890	12	8F1044	16	1J332	9

NUMERICAL PARTS INDEX

47

PART NO.	PAGE NO.	PART NO.	PAGE NO.	PART NO.	PAGE NO.	PART NO.	PAGE NO.
1J334	35	1J2291	8				
1J337	27	1J2292	8				
1J341	28	1J2668	12				
1J346	30	1J3162	29				
1J348	26	1J3347	12				
1J349	28	1J3665	37				
1J358	28	1J3930	38				
1J361	30	1J3931	38				
1J362	39	1J3932	38				
1J363	33	1J4012	37				
1J377	9	1J4036	36				
1J378	12	1K6982	34				
1J379	12	2K190	37				
1J380	12						
1J397	14						
1J398	10						
1J399	10						
1J400	10						
1J401	10						
1J403	10						
1J404	10						
1J405	10						
1J406	14						
1J430	9						
1J433	9						
1J434	9						
1J483	32						
1J490	14						
1J497	32						
1J498	32						
1J764	15						
1J774	13						
1J926	8						
1J930	8						
1J943	10						
1J962	8						
1J963	8						
1J964	10						
1J979	8						
1J980	8						
1J1084	12						
1J1150	19						
1J1267	12						
1J1268	12						
1J1531	22						
1J1532	22						
1J1533	23						
1J1534	23						
1J1554	40						
1J1666	38						
1J1741	40						
1J1755	40						
1J1757	40						
1J1784	40						
1J2080	37						
1J2087	37						
1J2089	37						
1J2100	37						
1J2111	37						
1J2137	37						
1J2144	37						
1J2145	37						
1J2147	37						
1J2148	37						
1J2149	37						
1J2150	37						
1J2152	37						
1J2174	37						
1J2175	37						
1J2176	37						
1J2177	37						
1J2188	21						
1J2194	37						
1J2198	37						
1J2200	37						

TO
2K190

SPECIFICATIONS

(SUBJECT TO CHANGE WITHOUT NOTICE)

	No. 8A	No. 8S	No. 8U
Weight, shipping (approximate) in pounds			
Equipped for use with front cable control . . .	6465	6110	6100
Equipped for use with rear cable control . . .	6610	6355	6240
Equipped for use with hydraulic control . . .	7000	6725	

CABLE

Size	1/2"	1/2"	1/2"
Length, for use with:			
Front cable control	52'	52'	52'
Rear cable control	72'	72'	72'

BLADE

Length	13' 5"	11' 11 1/2"	11' 11"
Height	44"	53"	45 1/4"
Maximum lift above ground	54 3/4"	48"	47 1/2"
Maximum blade pitch adjustment		10°	10°
Maximum blade tilting adjustment	24"	22"	16"

MACHINE SERIAL NUMBER PLATE LOCATION

Serial number plate is located on the right-hand side of the rear face of the moldboard.

NO. 8A, No. 8S & No. 8U BULLDOZER

18C, 44C & 11C SERIES

CATERPILLAR
MFG. CO. OF U. S. A.

PRINTED IN U. S. A.

FORM 32254