

**CATERPILLAR  
PARTS  
BOOK**

**977L  
TRAXCAVATOR**

Shop

**SERIAL  
NUMBERS**

**TK5051-UP**

# QUICK REFERENCE CHARTS

USE THESE CHARTS TO RECORD FREQUENTLY USED MAINTENANCE INFORMATION

MACHINE SERIAL NO.	
EQUIPMENT NO.	

## FREQUENTLY REPLACED ITEMS

PART NO.	PART NAME

## FLUIDS & LUBRICANTS

WHERE USED	TYPE	AMOUNT

## OTHER MAINTENANCE ITEMS

# CONTENTS

ALPHABETICAL INDEX OF GROUPS...	3
CONVERSION EQUIVALENT TABLES	INSIDE BACK COVER
ORDERING PARTS.....	2
QUICK REFERENCE CHART	INSIDE FRONT COVER
USING THE PARTS BOOK.....	2

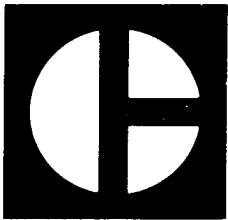

## PARTS BOOK

# 977L

## TRAXCAVATOR

SERIAL NUMBER  
11K5051-Up

PUBLISHED DECEMBER 1974  
CATERPILLAR TRACTOR CO.  
PUBLICATIONS DIV.—SERVICE G.O.  
PEORIA, ILL. U.S.A.  
COMPILED BY MARY ZELLER

# QUICK REFERENCE GUIDE TO MAJOR SECTIONS

ENGINE RELATED PARTS
STARTING & ELECTRICAL SYSTEM
POWER TRAIN—POWER TRANSMISSION UNIT
STEERING CLUTCHES & BRAKES
CHASSIS & UNDERCARRIAGE
HYDRAULIC SYSTEM
IMPLEMENTS
CAB, GAUGES & ACCESSORIES
SERVICE EQUIPMENT & SUPPLIES

## ORDERING PARTS

Quality Caterpillar Replacement parts are available from Caterpillar dealers throughout the world. Their parts stocks are up to date and include all parts normally required to protect your investment in Caterpillar machines. When ordering parts, always use the Parts Book covering the serial number of your machine. Your order should specify the quantity, part number, part name and show the machine serial number for which the parts are needed. If in doubt about the part number, please provide your dealer with a complete description of the needed item.

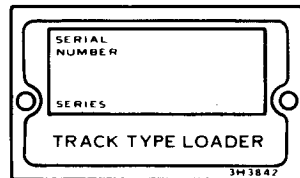

Serial Number Plate is located on top of Bevel Gear and Steering Clutch Case.

## HOW TO USE THE PARTS BOOK

Caterpillar Parts Books include illustrations of the groups or assemblies which make up the machine. These illustrations show the standard components of the machine plus many of the attachments available for the machine.

The alphabetical index located in the front part of the book should be used to determine the page number on which specific illustrations are shown. Reference to those pages will identify each of the individual serviceable parts.

### Captions

The caption under each illustration identifies the part number and name of the group or assembly shown. If more than one illustration is included for any group, the caption identifies the specific machine serial numbers to which each illustration applies. In some cases it is not possible to determine the specific machine serial numbers to which different illustrations are applicable. In those cases the caption identifies the illustration as "First Type", "Second Type", etc. Reference to the actual group or assembly is necessary in those cases to determine which illustration should be used.

Captions provide additional information such as page numbers where illustrations of sub assemblies are shown, information regarding quantities used and other information intended to assist the user in determining parts needs.

## Indented Part Names

Within each illustration is a parts list identifying each serviceable part in the illustration. When a part name is indented in this list, it means that serviceable item is a part of the serviceable item under which it is indented.

## Abbreviations and Symbols

- ▲ Used to call attention to additional information shown elsewhere within the illustration.
- 
- R.H. Right Hand Refers to the side of the machine as viewed from the operator's compartment.
- L.H. Left Hand
- C Indicates changes from the previous illustration of the same group or assembly.
- O.D. Outside Diameter
- I.D. Inside Diameter
- N/S Not Serviced
- Assem. Assembly
- in. Inch
- ft Foot
- cm Centimeter
- dm Decimeter

## Note:

Continuing improvement and advancement of product design may cause changes to your machine which may not be included in this publication. Each publication is reviewed and revised, as required, to update and include these changes in later editions.

Whenever a question arises regarding your Caterpillar product,\* or this publication, please consult your Caterpillar dealer for the latest available information.

# INDEX

THIS TRACTOR IS EQUIPPED WITH A 3306 ENGINE

FOR ENGINE PARTS INFORMATION USE THE PARTS BOOK FOR 3306 ENGINE, SERIAL NUMBER 3N1 — UP

THE SERIAL NUMBER PLATE ON THE ENGINE BLOCK PROVIDES SPECIFIC ENGINE IDENTITY

## Engine Related Parts

(Page 13)

Name	Page
Air Cleaner	19
Blower Fan and Guard	18
Engine Mounting Hardware	23
Fuel Tank	24
Fuel Tank Protection Cap	23
Governor Control	25
High Speed Oil Change	27
Hour Meter	28
Jacket Water Heater	18
Muffler	22
Noise Suppression	21
Precleaner	21
Prescreener	20
Pump — Fuel Priming	25
Radiator	14
Radiator Grill Hinged Plate	13
Radiator Guard	16
Torque Converter and Hydraulic Oil Cooler	26
Trunnion	28

## Starting and Electrical System

(Page 29)

Alternator	40
Backup Warning	49
Battery and Wiring	30
Electric Starting	34
Engine Function Warning	46
Lighting	41
Warning and Wiring	45

## Power Train — Power Transmission Unit

(Page 51)

Final Drive	80
-------------	----

Name	Page
Final Drive Guard	82
Lubrication System — Transmission & Steering Clutch	66
Planetary Transmission	62
Power Train	51
Pump — Transmission	79
Torque Converter	52
Transfer Gear	64
Transmission	57
Transmission Control Linkage	58
Transmission Filter	82
Transmission Hydraulic Control	59

## Steering Clutches and Brakes

(Page 83)

Band and Lining	88
Brakes	86
Steering Clutch	85
Steering Clutch Hydraulic Control	83

## Chassis and Undercarriage

(Page 89)

Bevel Gear Case and Covers	90
Bevel Gear Filler Spout Protection Cap	94
Bumper	99
Counterweight	100
Crankcase Guard	95
Drawbar	98
Front Idler	106
Front Pull Hook	98
Hood and Guard	96
Loader Frame	89
Recoil Mechanism Guard	105
Steel Mill Arrangement	103
Track	118
Track Carrier Roller	116

Name	Page
Track Guiding Guard	117
Track Roller	114
Track Roller Frame	110
Track Roller Guard	113

## Hydraulic System (Page 120)

Bucket Positioner	194
Conversion Arrangements	149
Cylinder — Lift	123
Cylinder — Tilt	127
Hand Control	120
Hydraulic Arrangements	148
Hydraulic Lines	184
Hydraulic Oil Cooler Lines	179
Hydraulic Tank Protection Cap	150
Kickout	196
Lift Cylinder Lines	142
Oil Filter Drain	193
Pump and Lines	180
Pump — Vane	181
Tank and Valve	151
Tilt Cylinder Lines	144

## Implements (Page 197)

Bucket	202
Bucket Control	198
Bucket—Demolition	208
Bucket Guard	197
Bucket—Multi-Purpose	202A
Bucket—Side Dump	206
Cutting Edge	214
Cylinder Mounting	197

Name	Page
Log Fork	210
Teeth	211
Top Clamp	209

## Cab, Gauges and Accessories (Page 214)

Air Conditioner	232
Cab Heater	229
Condenser Service Door	235
Defrosting Fan	232
Electric Horn	228
Floor Plate, Guard & Grab Iron	224
Gauges and Instrument Panel	225
Mounting—ROPS	246
Refrigerant Compressor	233
Roll-Over Protective Structure	249
Seat—Adjustable	222
Seat Cushion and Frame	216
Sound Suppression	214B
Support—Fuel Tank, Hydraulic Tank and Seat	215
Vandalism Protection	227
Water Pressure Gauge	226
Windshield Wiper	227

## Service Equipment and Supplies (Page 252)

Gasket Kits	253
Hand Tool	252
Specifications	256
Transfers	254

# INDEX ALPHABÉTIQUE

CE CHARGEUR EST MUNI D'UN MOTEUR 3306.

POUR LES PIÈCES DE RECHANGE DU MOTEUR, VOIR LE CATALOGUE DE PIÈCES DES MOTEURS 3306 À PARTIR DU N° DE SÉRIE 3N1.

LA PLAQUE FIXÉE AU BLOC-MOTEUR DONNE LE NUMÉRO DE SÉRIE ET AUTRES RÉFÉRENCES DU CATALOGUE.

## Pièces de complément du moteur (Page 13)

Désignation	Page
Chapeau de sécurité (réservoir de carburant) .....	23
Dispositif de vidange et remplissage rapide (huile) .....	27
Filtre à air .....	19
Grille de radiateur à charnières ..	13
Groupe d'insonorisation .....	21
Horomètre .....	28
Pièces de fixation du moteur .....	23
Pompe d'amorçage .....	25
Préfiltre à air .....	21
Protège-radiateur .....	16
Radiateur .....	14
Réchauffeur d'eau de cylindres ..	18
Réfrigérant d'huile hydraulique et du convertisseur .....	26
Régulateur (timonerie extérieure) ..	25
Réservoir de carburant .....	24
Silencieux d'échappement .....	22
Tamis de préfiltre .....	20
Tourillons .....	28
Ventilateur soufflant et protection ..	18

## Démarrage et installation électrique (Page 29)

Alternateur .....	40
Avertisseur d'alarme (moteur) .....	46
Avertisseur de marche arrière .....	49
Avertisseur et câblage .....	45
Batterie et câblage .....	30
Démarrage électrique .....	34
Éclairage .....	41

## Train de transmission (Page 51)

Circuit de graissage (transmission et embrayages de direction) ..	66
Convertisseur de couple .....	52
Engrenages de transfert .....	64
Filtre du circuit de transmission ..	82
Mécanisme de transmission .....	51
Pompe de transmission .....	79

Désignation	Page
Protège-réducteurs latéraux .....	82
Réducteurs latéraux .....	80
Transmission .....	57
Transmission à trains planétaires ..	62
Tringlerie de commande des vitesses .....	58
Vitesses (commande hydraulique) ..	59

## Embrayages de direction et freins (Page 83)

Bandage de frein et garniture ..	88
Embrayages de direction .....	85
Embrayages de direction (commande hydraulique) .....	83
Freins .....	86

## Bâti et train de roulement (Page 89)

Barre d'attelage .....	98
Bâti AR .....	90
Bâti de l'appareil de levage .....	89
Capot et protège-radiateur .....	96
Chaînes de roulement .....	118
Chapeau de sécurité (remplissage du couple conique) ..	94
Châssis porteurs .....	110
Contrepoids .....	100
Crochet d'attelage avant .....	98
Équipement pour aciéries .....	103
Galets inférieurs .....	114
Galets supérieurs .....	116
Guide-protecteur de chaîne .....	117
Pare-chocs .....	99
Protège-carter moteur .....	95
Protège-galets .....	113
Roues avant .....	106
Tendeur hydraulique (capot protecteur) .....	105

## Circuit hydraulique (Page 120)

Arrêt automatique de fin de levage .....	196
---	-----

Désignation	Page
Canalisations du vérin de levage	142
Canalisations du vérin d'inclinaison	144
Canalisations hydrauliques	184
Chapeau de sécurité (réservoir hydraulique)	150
Commande manuelle	120
Commandes hydrauliques	148
Filtre à huile (vidange)	193
Groupes de transformation	149
Pompe à palettes	181
Pompe et canalisations	180
Réservoir et valve sélective	151
Retour automatique à l'angle d'attaque	194
Tuyauterie du réfrigérant d'huile hydraulique	179
Vérin de levage	123
Vérin d'inclinaison	127

### **Équipement de travail (Page 197)**

Bord tranchant	214
Bras et bielles de godet	198
Dents	211
Fourche à grumes	210
Godet	202
Godet à déversement latéral	206
Godet de démolition	208
Godet (protecteur)	197
Griffe supérieure pour fourche	209
Vérins (groupe de montage)	197

### **Cabine, instruments de contrôle et accessoires (Page 214)**

Désignation	Page
Avertisseur électrique	228
Bâti de sécurité	249
Chauffage de la cabine	229
Climatiseur	232
Compresseur de climatiseur	233
Dégivreur	232
Dispositifs anti-vandalisme	227
Essuie-glace	227
Groupe de pose pour bâti de sécurité	246
Manomètre de pression d'eau	226
Plate-forme, protecteurs et poignée	224
Porte de visite du condenseur	235
Siège et support	216
Siège réglable	222
Support (réservoirs hydraulique et de carburant, et siège)	215
Tableau de bord et instruments de contrôle	225

### **Divers (Page 252)**

Caractéristiques	257
Instructions sur décalcomanies	254
Jeux de joints	253
Outils à main	252

## **I N D I C E**

ESTE TRAXCAVATOR ESTA EQUIPADO CON UN MOTOR 3306.

LA INFORMACION ACERCA DE LAS PARTES DEL MOTOR SE ENCUENTRA EN EL CATALOGO DE REPUESTOS PARA LOS MOTORES 3306, CON NUMERO DE SERIE 3NI Y SIGUIENTES.

LA PLACA CON EL NUMERO DE SERIE EN EL BLOQUE DEL MOTOR PROVEE LA IDENTIFICACION ESPECIFICA DEL MOTOR.



## Partes Relacionadas con el Motor (Página 13)

Nombre	Página
Antefiltro .....	21
Antefiltro especial .....	20
Bomba de cebado del combustible	25
Calentador del agua de las camisas .....	18
Cambio de aceite rápido .....	27
Control del regulador .....	25
Enfriador del convertidor de par y aceite hidráulico .....	26
Filtro de aire .....	19
Herrajes para el montaje del motor .....	23
Medidor del servicio .....	28
Muñón .....	28
Protección del radiador .....	16
Protección de reja engoznada para el radiador .....	13
Radiador .....	14
Silenciador .....	22
Supresor de ruido .....	21
Tanque de combustible .....	24
Tapa protectora del tanque de combustible .....	23

## Sistemas de Arranque y Eléctrico (Página 29)

Alarma para el retroceso .....	49
Alarma y alambrado .....	45
Alternador .....	40
Arranque eléctrico .....	34
Batería y alambrado .....	30
Bocina y luz de alarma de baja presión del aceite y alta temperatura del agua .....	46
Luces .....	41

## Tren de Potencia — Unidad de Transmisión de Fuerza (Página 51)

Bomba de la transmisión .....	79
-------------------------------	----

Nombre	Página
Control hidráulico de la transmisión .....	59
Convertidor de par .....	52
Engranaje de transferencia .....	64
Filtro de la transmisión .....	82
Mandos finales .....	80
Protección de mandos finales .....	82
Sistema de lubricación de la transmisión y embrague de dirección .....	66
Transmisión .....	57
Transmisión planetaria .....	62
Tren de potencia .....	51
Varillaje de control de la transmisión .....	58

## Embragues de Dirección y Frenos (Página 83)

Banda y revestimiento .....	88
Control hidráulico del embrague de dirección .....	83
Embrague de dirección .....	85
Frenos .....	86

## Chasis y Tren de Rodaje (Página 89)

Barra de tiro .....	98
Bastidor del cargador .....	89
Bastidor de rodillo .....	110
Caja y tapas de la corona	90
Carril .....	118
Capota y protección .....	96
Conjuntos para acerías .....	103
Contrapeso .....	100
Gancho delantero .....	98
Parachoques .....	99
Protección del cárter .....	95
Protección guía del carril .....	117
Protección del mecanismo tensor	105
Protección de rodillos inferiores	113
Rodillos inferiores .....	114
Rodillos superiores .....	116
Rueda guía .....	106
Tapa protectora de tubo de llenado de la corona .....	94

## Sistema Hidráulico (Página 120)

Nombre	Página
Bomba de paletas	181
Bomba y tuberías	180
Cilindro de inclinación	127
Cilindro de levantamiento	123
Conjuntos de conversión	149
Conjuntos hidráulicos	148
Control manual	120
Desenganche automático	196
Tanque y válvula	151
Tapa protectora del tanque hidráulico	150
Tuberías del aceite hidráulico	179
Tuberías de cilindro de inclinación	144
Tuberías de cilindro de levantamiento	142
Tuberías hidráulicas	184
Ubicador del cucharón	194
Vaciado del filtro del aceite	193

## Implementos (Página 197)

Control del cucharón	198
Cucharón	202
Cucharón de descarga lateral	206
Cucharón para demolición	208
Cuchilla	214
Dientes	211
Horquilla maderera	210
Montaje de cilindro	197
Protección del cucharón	197
Tenaza	209

## Cabina, Instrumentos y Accesorios (Página 214)

Nombre	Página
Acondicionador de aire	232
Asiento ajustable	222
Bocina eléctrica	228
Calentador de la cabina	229
Cojín y asiento del bastidor	216
Compresor de refrigerante	233
Estructura Protectora contra Vuelcos	249
Instrumentos y tablero de instrumentos	225
Limpiaparabrisas	227
Manómetro de agua	226
Montaje para Estructura Protectora contra Vuelcos	246
Plancha del piso, protección y manilla	224
Protección contra vandalismo	227
Soporte de tanque de combustible, tanque hidráulico y asiento	215
Tapa de servicio del condensador	235
Ventilador descongelador	232

## Materiales Diversos (Página 252)

Calcomanías	254
Especificaciones	258
Herramientas manuales	252
Juegos de empaquetadura	253

# ÍNDICE

O MOTOR DESTA MÁQUINA É O MODELO 3306.

PARA INFORMAÇÕES SOBRE PEÇAS DO MOTOR VEJA O CATÁLOGO DE PEÇAS DOS MOTORES 3306 COM NÚMERO DE SÉRIE A PARTIR DE 3NI.

A PLACA DO NÚMERO DE SÉRIE NO BLOCO DO MOTOR O IDENTIFICA ESPECIFICAMENTE.

## **Partes da máquina relativas ao motor**

**(Página 13)**

Designação	Página
Aquecedor d'água do motor . . .	18
Arranjo de troca rápida de óleo .	27
Arranjo silenciador . . . . .	21
Bomba de purgação do combustível . . . . .	25
Controle de aceleração . . . . .	25
Conversor de torque e arrefecedor do óleo hidráulico	26
Ferragens miúdas para montagem do motor . . . . .	23
Grade articulada do radiador . .	13
Horômetro . . . . .	28
Moldura do radiador . . . . .	16
Munhão . . . . .	28
Pré-purificador . . . . .	21
Pré-purificador com tela . . . . .	20
Purificador de ar . . . . .	19
Radiador . . . . .	14
Silenciador . . . . .	22
Tampa do tanque de combustível com cadeado . . . .	23
Tanque de combustível . . . . .	24
Ventilador insuflador e protetor .	18

## **Sistema elétrico e de partida**

**(Página 29)**

Alarme de marcha à ré . . . . .	49
Alarme do motor . . . . .	46
Alarme e instalação . . . . .	45
Bateria e instalação elétrica . . .	30
Gerador alternador . . . . .	40
Partida elétrica . . . . .	30
Sistema de iluminação . . . . .	41

## **Sistema de transmissão**

**(Página 51)**

Designação	Página
Bomba do sistema de transmissão	79
Caixa de mudanças . . . . .	57
Comando final . . . . .	80
Controle hidráulico da caixa de mudanças . . . . .	59
Conversor de torque . . . . .	52
Engrenagens da caixa de mudanças . . . . .	62
Engrenagens de transferência . . .	64
Filtro da caixa de mudanças . . . .	82
Ligações de controle das marchas	58
Protetor do comando final . . . . .	82
Sistema de lubrificação da caixa de mudanças e embreagens de direção . . . . .	66
Sistema de transmissão . . . . .	51

## **Embreagens de direção e freios**

**(Página 83)**

Cinta do freio e lona . . . . .	88
Controle hidráulico das embreagens de direção . . . . .	83
Embreagem de direção . . . . .	85
Freios . . . . .	86

## **Chassi e material rodante**

**(Página 89)**

Armação dos roletes . . . . .	110
Arranjo siderúrgico . . . . .	103
Barra de tração . . . . .	98
Caixa da coroa e tampas . . . . .	90
Capô e protetor . . . . .	96

Designação	Página
Chassi dos braços .....	89
Contrapeso .....	100
Esteira .....	118
Gancho dianteiro .....	98
Pára-choque .....	99
Protetor do cárter .....	95
Protetor dos roletes das esteiras	113
Protetor e guia da esteira .....	117
Roda-guia .....	106
Rolete inferior .....	114
Rolete superior .....	116
Tampa da mola tensora .....	105
Tampa do bocal de enchimento da caixa da coroa .....	94

## Sistema hidráulico

(Página 120)

Alavanca de controle .....	120
Arranjos de conversão .....	149
Arranjos hidráulicos .....	148
Assentador da caçamba .....	194
Bomba de palhetas .....	181
Bomba e tubulações .....	180
Cilindro de inclinação .....	127
Cilindro elevador .....	123
Dreno do filtro de óleo .....	193
Limitador da elevação .....	196
Reservatório e válvula .....	151
Tampa do reservatório hidráulico com cadeado .....	150
Tubulações do arrefecedor de óleo .....	179
Tubulações do cilindro elevador	142
Tubulações do cilindro de inclinação .....	144

## Implementos

(Página 197)

Borda cortante .....	214
Braços da caçamba .....	198

Designação	Página
Caçamba .....	202
Caçamba de demolição .....	208
Caçamba de despejo lateral .....	206
Dentes .....	211
Garfo de toras .....	210
Garra superior .....	209
Protetor da caçamba .....	197
Suporte do cilindro .....	197

## Cabine, indicadores e acessórios

(Página 214)

Almofada do assento e armação	216
Aquecedor da cabine .....	229
Assento ajustável .....	222
Buzina elétrica .....	228
Chapa do piso, protetor e alças	224
Compressor do refrigerador .....	233
Desembaciador do pára-brisa .....	232
Estrutura de segurança .....	249
Limpador do pára-brisa .....	227
Manômetro d'água .....	226
Montagem para estrutura de segurança .....	246
Painel de instrumentos .....	225
Refrigerador de ar da cabine .....	232
Suporte do assento, tanque de combustível e reservatório hidráulico .....	215
Tampa de acesso ao condensador do refrigerador de ar .....	239
Tampas com cadeado .....	227

## Diversos

(Página 252)

Decalcomanias .....	254
Especificações .....	259
Ferramentas manuais .....	252
Jogos de juntas .....	253

# INHALTSVERZEICHNIS

DIESE MASCHINE IST MIT EINEM MOTOR 3306 BESTÜCKT.

ERSATZTEILE FÜR DIESEN MOTOR SIND IM ERSATZTEILBUCH FÜR MOTOREN 3306 AB SERIENNUMMER 3N1 AUFGEFÜHRT.

DAS SERIENNUMMERNSCHILD AM MOTORBLOCK DIENST ZUR GENAUEN TYPENBESTIMMUNG.

## Motorzubehör

(Seite 13)

Bezeichnung	Seite
Drucklüfter und Verkleidung . . . .	18
Halteteile . . . . .	23
Kraftstoffentlüftungspumpe . . . .	25
Kraftstofftank . . . . .	24
Kühlernetz . . . . .	14
Kühlerschutz . . . . .	16
Kühlerverkleidung mit Scharnieren	13
Kühlwasserheizung . . . . .	18
Luftreiniger . . . . .	19
Montagezapfen . . . . .	28
Ölschnellwechsellanschluß . . . .	27
Reglersteuerung . . . . .	25
Schalldämpfer . . . . .	22
Schallsolierung . . . . .	21
Tankkappe . . . . .	23
Vorabscheider . . . . .	20
Vorreiniger . . . . .	21
Wandler- und Hydraulikölkühler .	26
Wartungsmesser . . . . .	28

## Anlasser und elektr. Anlage

(Seite 29)

Anlasser, elektr. . . . .	34
Batterie und Verdrahtung . . . . .	30
Beleuchtungsanlage . . . . .	41
Drehstromlichtmaschine . . . . .	40
Motorwarnsystem . . . . .	46
Rückfahrwarnhorn . . . . .	49
Warnanlage und Verdrahtung . . .	45

## Kraftübertragung — Getriebe

(Seite 51)

Bezeichnung	Seite
Drehmomentwandler . . . . .	52
Getriebe . . . . .	57
Getriebehydraulik . . . . .	59
Getriebepumpe . . . . .	79
Getriebebeschaltgestänge . . . . .	58
Getriebeschmierfilter . . . . .	82
Getriebe- und Lenk Kupplungs- schmiersystem . . . . .	66
Kraftübertragung . . . . .	51
Planetengetriebe . . . . .	62
Seitenantrieb . . . . .	80
Seitenantriebsverkleidung . . . . .	82
Vorgelege . . . . .	64

## Lenk Kupplungen und Bremsen

(Seite 83)

Bremsband und Belag . . . . .	88
Bremsen . . . . .	86
Lenk Kupplung . . . . .	85
Lenk Kupplungshydraulik . . . . .	83

## Fahr- und Laufwerk

(Seite 89)

Frontzughaken . . . . .	98
-------------------------	----

Bezeichnung	Seite
Gegengewicht	100
Hüttenwerksausführung	103
Kettenführungsplatten	117
Laderrahmen	89
Laufkette	118
Laufrollen	114
Laufrollenführung	113
Laufwerksrahmen	110
Leitrad	106
Motorhaube und Verkleidung	96
Panzerwanne	95
Stoßstange	99
Stützrolle	116
Tellerradgehäuse-Füllstutzendeckel	94
Tellerradgehäuse und Deckel	90
Verkleidung des Kettenspanners	105
Zughaken	98

## Hydraulikanlage

(Seite 120)

Handsteuerung	120
Hubausschalter	196
Hubzylinder	123
Hubzylinderleitungen	142
Hydraulikanordnung	148
Hydraulikleitungen	184
Hydraulikölkühlerleitungen	179
Hydrauliktankkappe	150
Kippzylinder	127
Kippzylinderleitungen	144
Messerpumpe	181
Ölfilterablaß	193
Pumpe und Leitungen	180
Schaufeleinsteller	194
Tank und Ventil	151
Umbaugruppen-Übersicht	149

## Anbaugeräte

(Seite 197)

Abbruchschaufel	208
-----------------	-----

Bezeichnung	Seite
Halteklammer	209
Holzladegabel	210
Leitungsschutz	197
Schaufel	202
Schaufelmesser	214
Schaufelgestänge	198
Schaufelzähne	211
Seitenkippschaufel	206
Zylinderaufhängung	197

## Fahrerhaus, Armaturen und Zubehör

(Seite 214)

Anzeigen und Armaturen Brett	225
Bodenblech, Verkleidung und Handgriff	224
Entfrostergebläse	232
Fahrerhausheizung	229
Fahrersitz, verstellbar	222
Fahrersitz-, Kraftstofftank- und Hydrauliktankunterbau	215
Hupe	228
Klimaanlage	232
Kondensatorwartungsdeckel	235
Kühlkompressor	233
Scheibenwischer	227
Schutzabdecke	227
Sitzkissen und -rahmen	216
Überroll-Schutzdach	249
Überroll-Schutzdachauflager	246
Wasserdruckanzeige	226

## Wartungsgerät und Zubehör

(Seite 252)

Abziehbilder	254
Dichtungssätze	253
Handwerkzeuge	252
Technische Daten	260

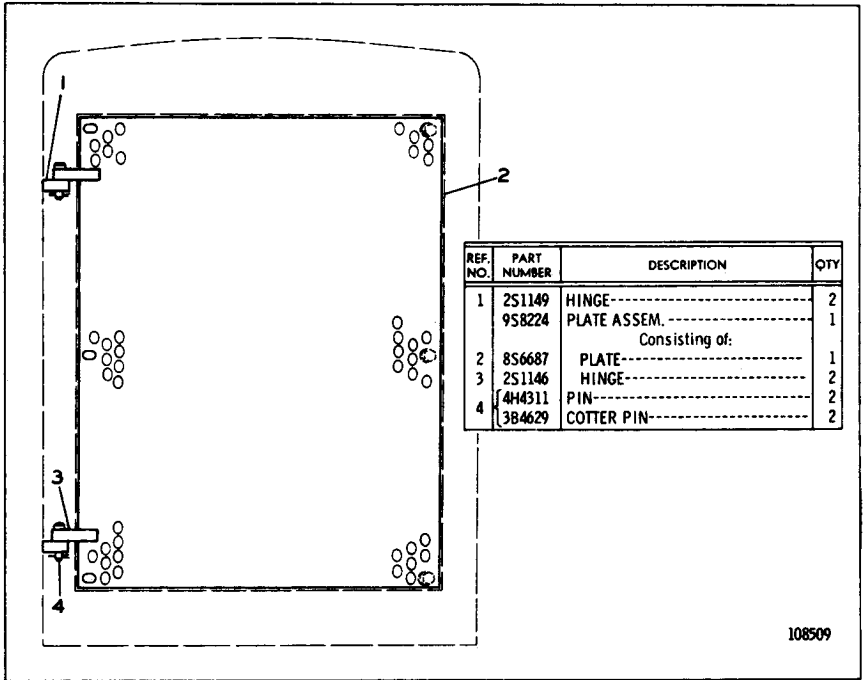

108509

9S8225 RADIATOR GRILL HINGED PLATE GROUP—Factory Installation  
AN ATTACHMENT

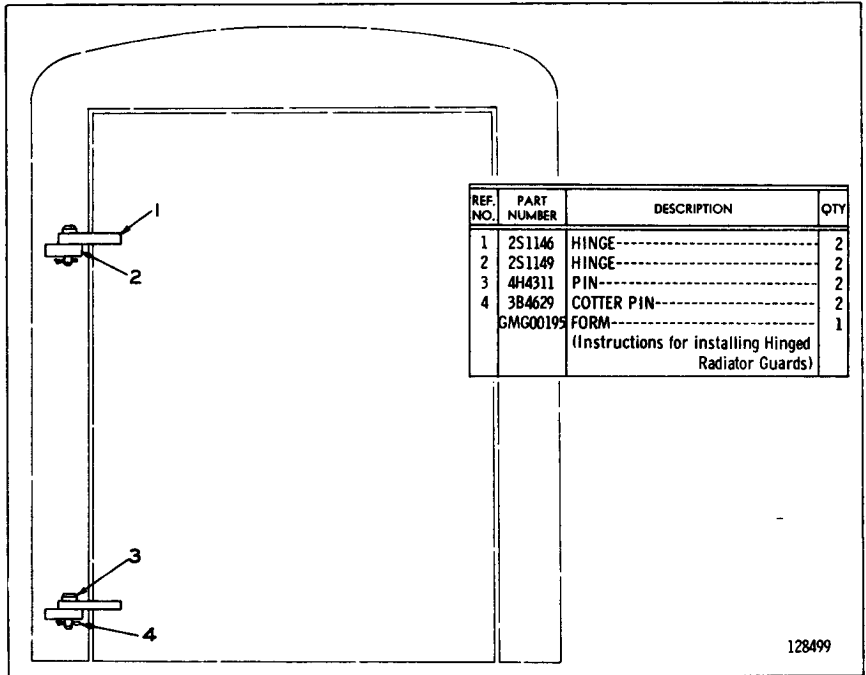

128499

9S7870 RADIATOR GUARD HINGE GROUP—Field Installation

CATERPILLAR 977L TRAXCAVATOR

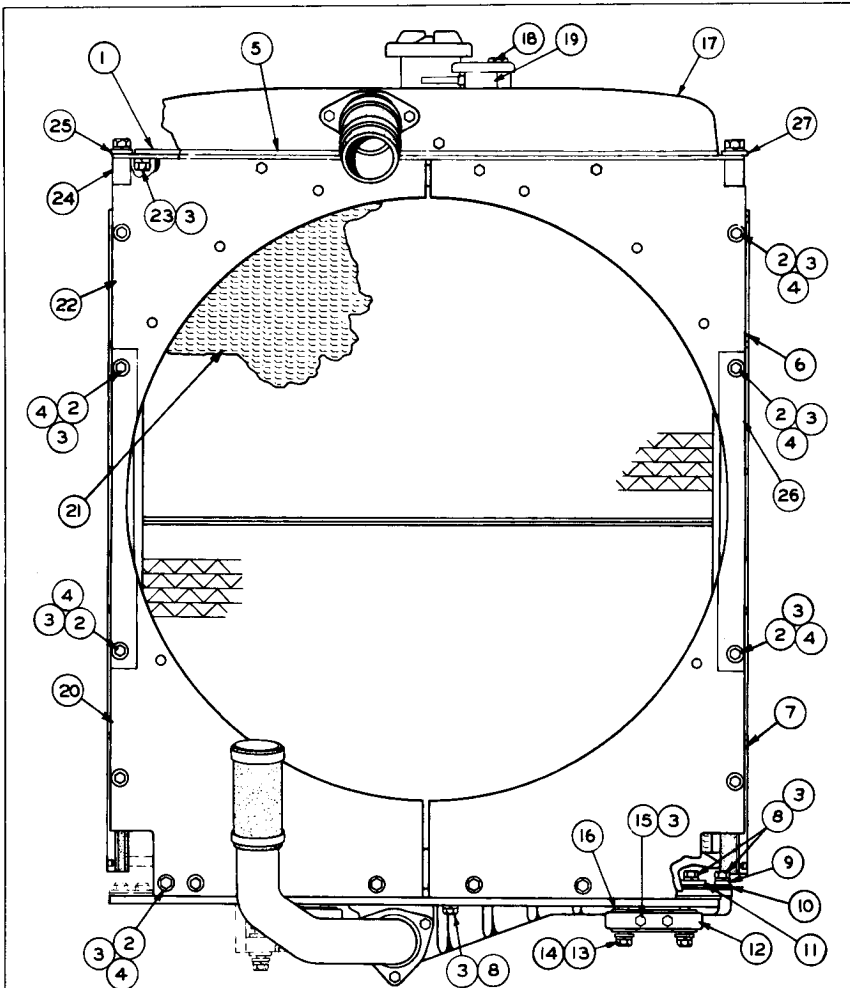

REF. NO.	PART NUMBER	DESCRIPTION	QTY
1	1P2295	STRIP-----	1
2	L1351	BOLT-----	20
3	3B4506	LOCKWASHER-----	64
4	4B4278	WASHER-----	20
5	1P2296	STRIP-----	1
6	1P2279	SHIELD ASSEM.-----	1
7	9F2978	NUT-----	3
8	8S6093	SHIELD ASSEM.-----	1
9	9F2978	NUT----- (Weld)	1
10	1A2029	BOLT-----	27
11	1P2306	STRIP-----	3
12	1P1445	GASKET-----	1
13	7S666	STRIP-----	2

14	2M4998	CLAMP-----	4
15	L1329	BOLT-----	4
16	4B4280	WASHER-----	8
17	3B4508	LOCKWASHER-----	4
18	S1619	BOLT-----	4
19	3H8726	BLOCK-----	4
20	1P9198	TANK ASSEM.-----	1
21	1S286	STUD-----	1
22	5M6214	PLUG-----	1
23	4N4579	NECK ASSEM.-----	1
24	8S6094	SHIELD ASSEM.-----	1
25	9F2978	NUT----- (Weld)	1
26	1P1683	CORE ASSEM.----- (Radiator)	1
27	1P2284	SHIELD ASSEM.-----	1
28	9F2978	NUT-----	3
29	S1594	BOLT-----	13
30	1P1740	SUPPORT-----	1
31	1P2307	STRIP-----	1
32	2P2433	BAFFLE-----	2
33	1P2308	STRIP-----	1

118387

RADIATOR (2P8206 N/S)—Rear View  
 Note: 6F6041 Rust Inhibitor is available



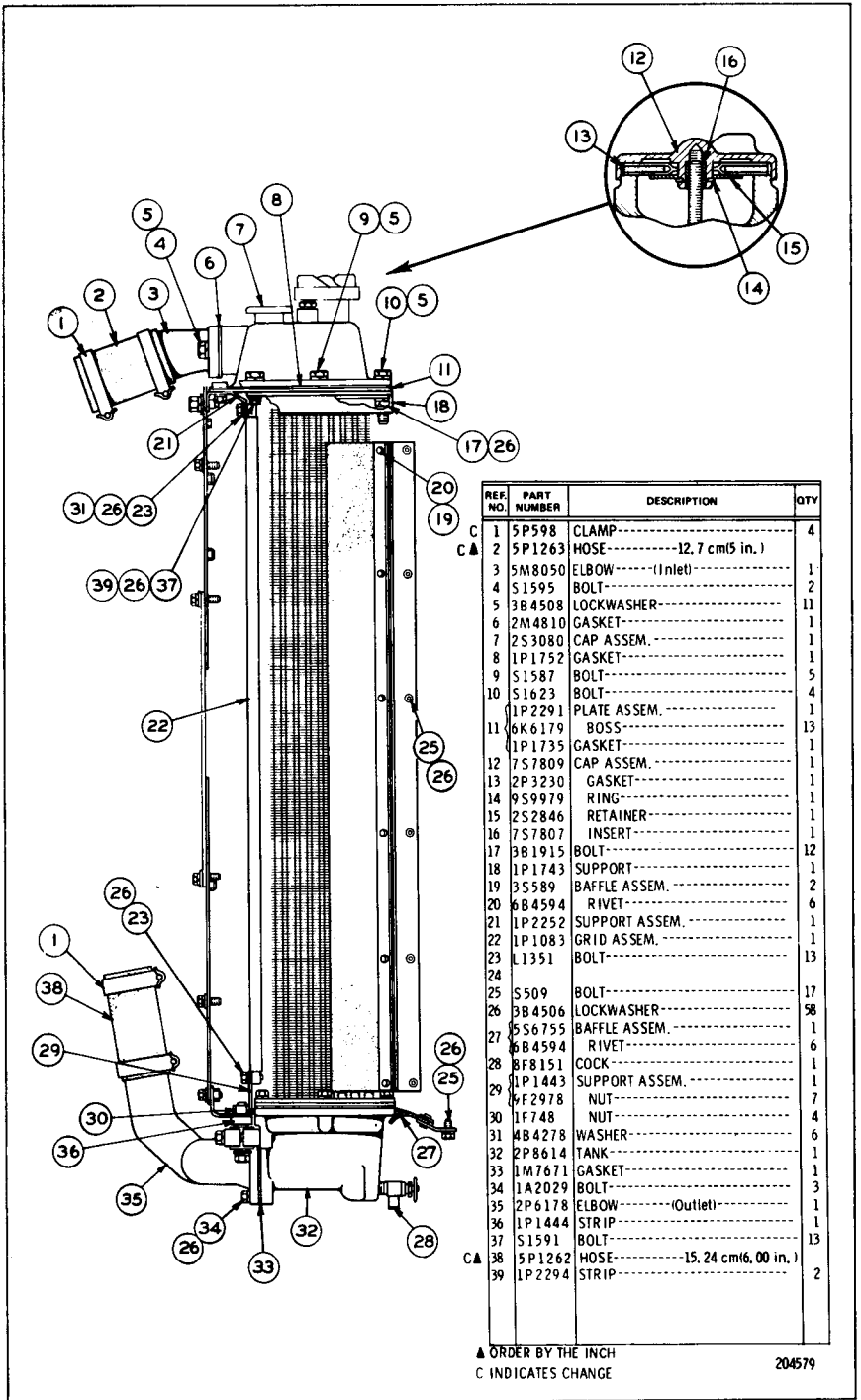

RADIATOR (2P8206 N/S)—Side View

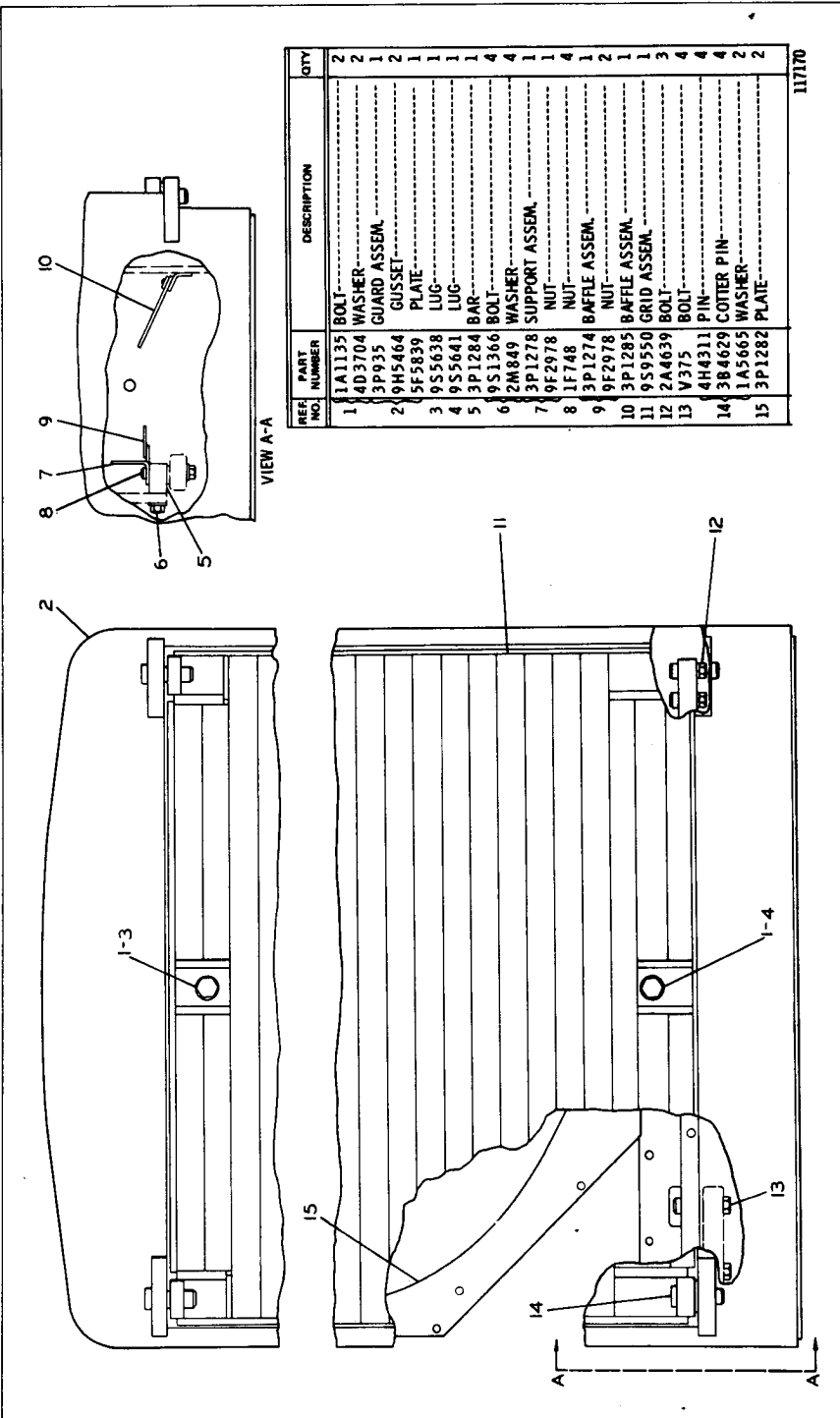

REF. NO.	PART NUMBER	DESCRIPTION	QTY
1	1A1135	BOLT	2
2	4D3704	WASHER	2
3	3P935	GUARD ASSEM.	1
4	9H5464	GUSSET	2
5	5F5839	PLATE	1
6	9S5638	LUG	1
7	9S5641	LUG	1
8	3P1284	BAR	1
9	9S1366	BOLT	4
10	2M849	WASHER	4
11	3P1278	SUPPORT ASSEM.	1
12	9F2978	NUT	1
13	1F748	NUT	4
14	3P1274	BAFFLE ASSEM.	4
15	9F2978	NUT	2
16	3P1285	BAFFLE ASSEM.	1
17	9S9550	GRID ASSEM.	1
18	2A4639	BOLT	3
19	V375	BOLT	4
20	4H4311	PIN	4
21	4A384629	COTTER PIN	4
22	1A5665	WASHER	2
23	3P1282	PLATE	2

11770

3P1886 RADIATOR GUARD GROUP  
AN ATTACHMENT

3P1887 RADIATOR GUARD GROUP  
 Also part of 1P9409 Steel Mill Traxcavator Arrangement listed on Page 104  
 AN ATTACHMENT

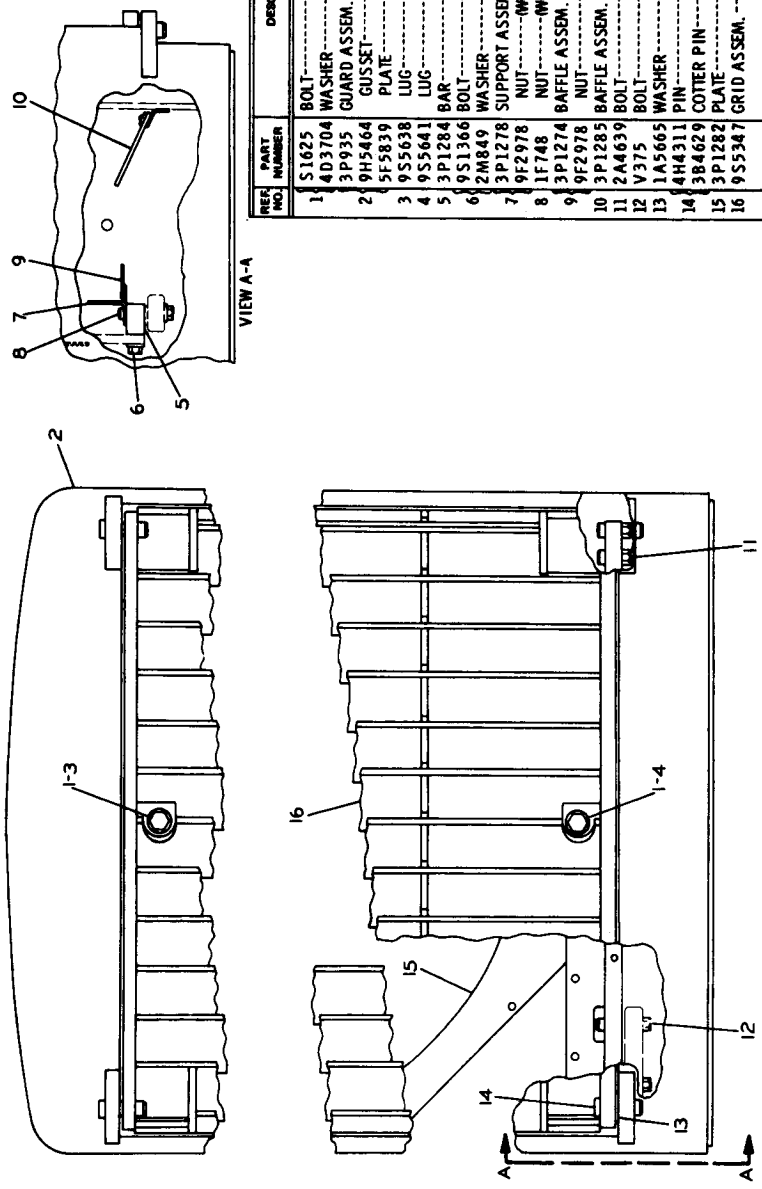

REF. NO.	PART NUMBER	DESCRIPTION	QTY
1	S1625	BOLT	2
	4D3704	WASHER	2
	3P935	GUARD ASSEM.	1
2	9H5464	GUSSET	2
	5F5839	PLATE	1
3	9S5038	LUG	1
4	9S5641	LUG	1
5	3P1284	BAR	1
6	9S1366	BOLT	4
	2M849	WASHER	4
7	3P1278	SUPPORT ASSEM.	1
	9F2978	NUT (Weld)	1
8	1F748	NUT (Weld)	4
9	3P1274	BAFFLE ASSEM. (Weld)	1
	9F2978	NUT (Weld)	1
10	3P1285	BAFFLE ASSEM.	3
	2A4639	BOLT	3
12	V375	BOLT	4
13	1A5665	WASHER	2
	4H4311	PIN	4
14	3B4629	COITER PIN	4
15	3P1282	PLATE	2
16	9S5347	GRID ASSEM.	1

11658

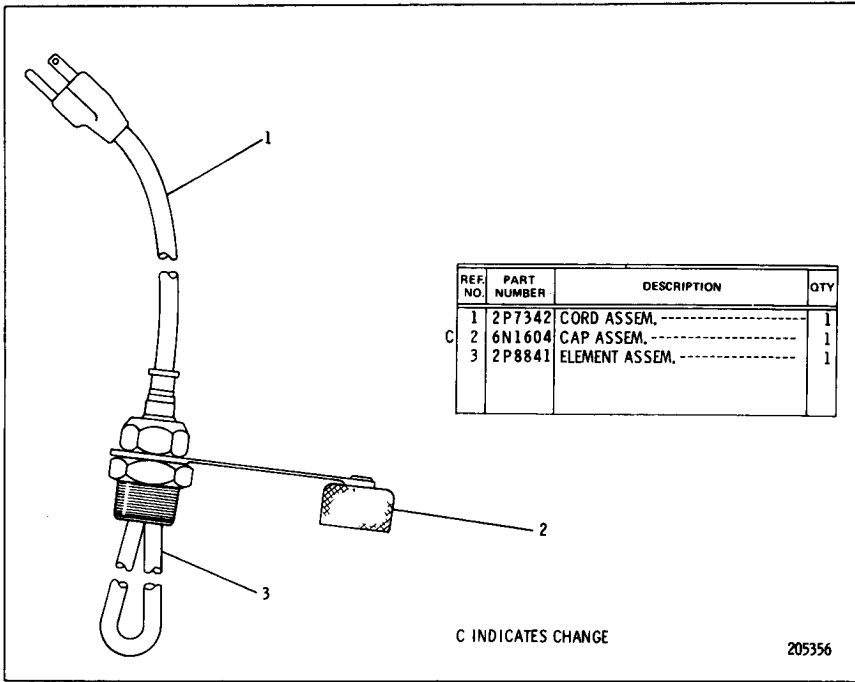

4N3586 JACKET WATER HEATER GROUP AN ATTACHMENT

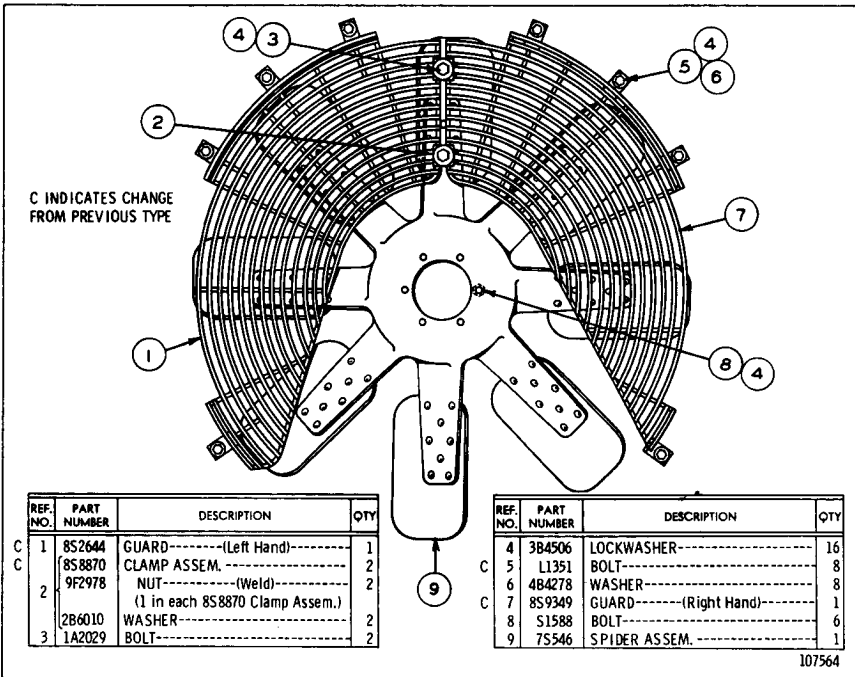

BLOWER FAN AND GUARD (7S1161 N/S)

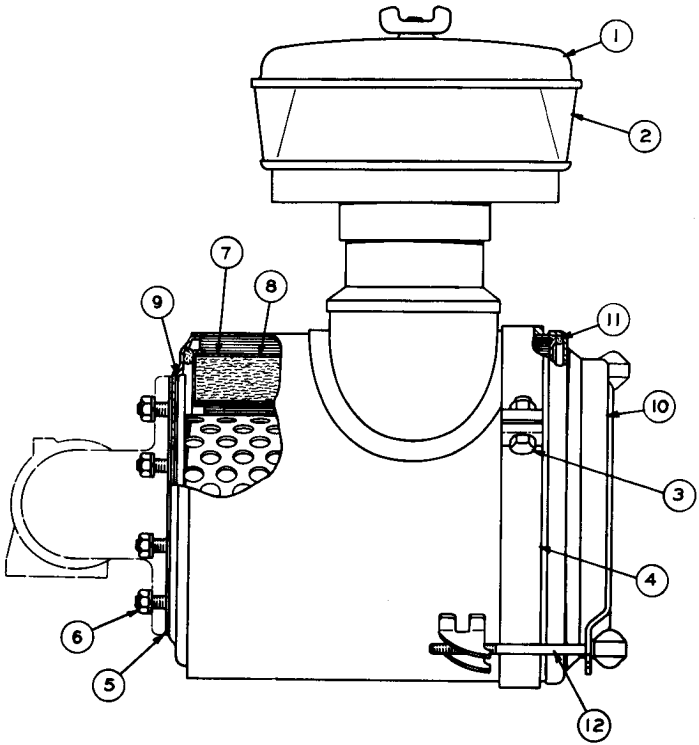

C INDICATES CHANGE FROM PREVIOUS TYPE

REF. NO.	PART NUMBER	DESCRIPTION	QTY
1	5L7942	PRECLEANER ASSEM. -----	1
1	9M5201	COVER ASSEM. -----	1
2	6H8021	BODY -----	1
		(Parts of 5L7942 Assem.)	
	1A1460	BOLT -----	1
3	1D4719	NUT -----	1
	4B4280	WASHER -----	1
4	1S1739	BAND -----	1
5	4M4299	GASKET -----	1
6	1D4717	NUT -----	8
C	3B4506	LOCKWASHER -----	8

	3S2298	AIR CLEANER ASSEM. -----	1	
		Consisting of:		
7	7M9045	ELEMENT ----- (Primary) -----	1	
8	2S1287	ELEMENT ----- (Secondary) -----	1	
9	4M4299	GASKET -----	1	
		(Part of 2S1287 Element)		
10	9M4895	CUP ASSEM. -----	1	
11	9M8513	GASKET -----	1	
		(Part of 9M4895 Assem.)		
C	12	4S6818	ROD ASSEM. -----	2

129758

AIR CLEANER (7S1834 N/S)

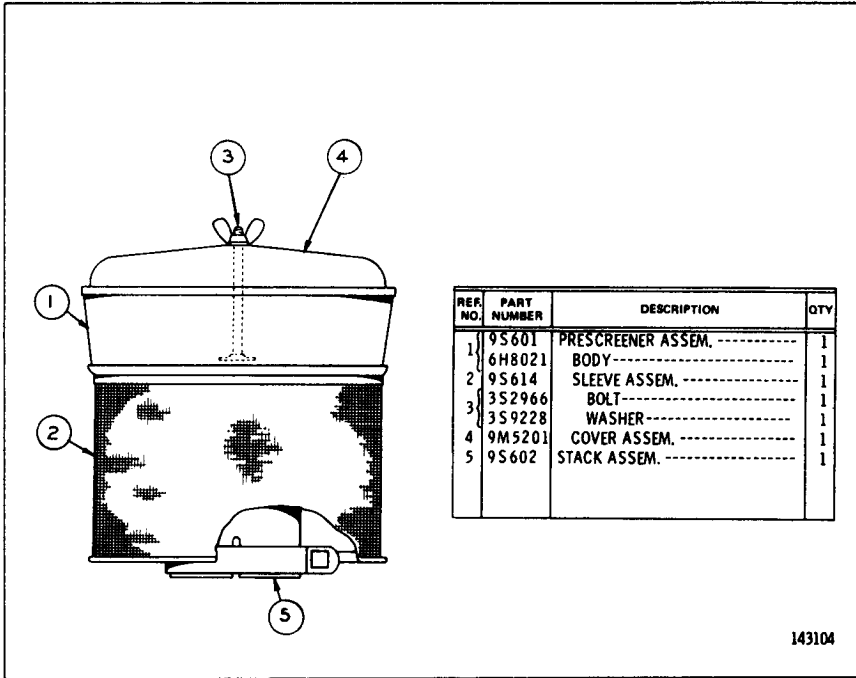

**9S603 PRESCREENER GROUP**  
**FOR USE WITH SANITARY LANDFILL AND LOGGING**  
**AN ATTACHMENT**

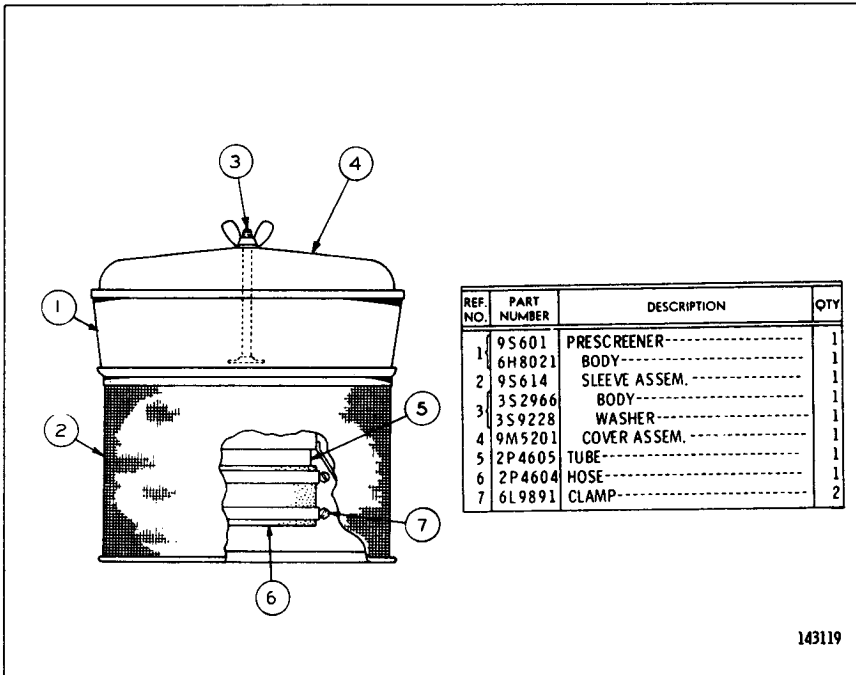

**2P4937 PRESCREENER GROUP**  
**Part of 2P4859 Noise Suppression Arrangement**  
**AN ATTACHMENT**

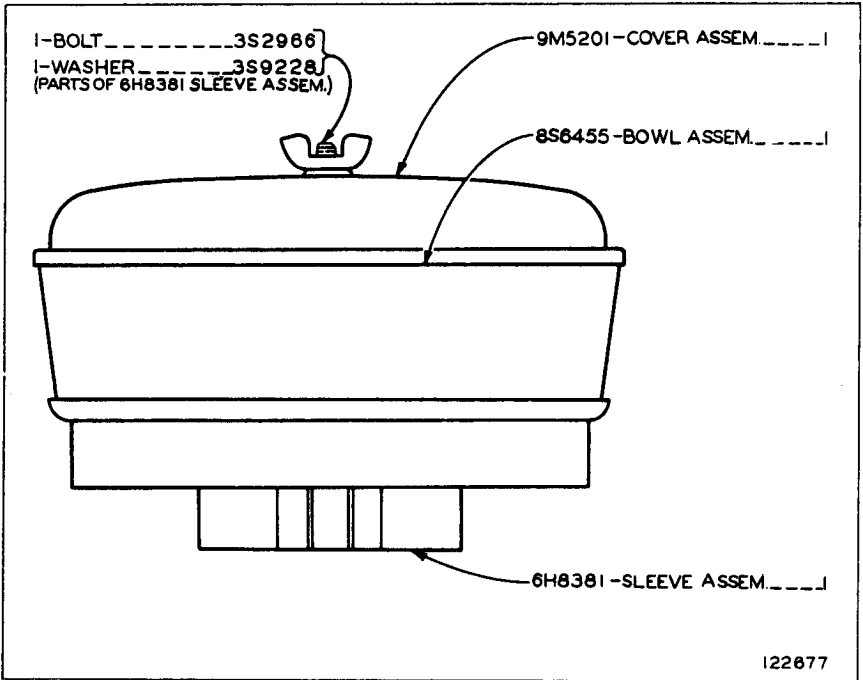

8S6454 PRECLEANER ASSEMBLY  
 Part of 5S3270 & 1P9409 Steel Mill Traxcavator Arrangements listed on  
 Pages 103 & 104. AN ATTACHMENT

CONSISTS OF:			PAGE
1	2P4609	MUFFLER GROUP.....	22
1	2P4937	PRESCREENER GROUP.....	20
1	5L8855	RING--COUPLING	
1	2P4610	EXHAUST ELBOW	
1	2P4830	COLLAR--TO HOOD ASSEMBLY	
1	5S5077	COUPLING--TURBINE TO EXHAUST ELBOW	

C INDICATES CHANGE FROM PREVIOUS TYPE

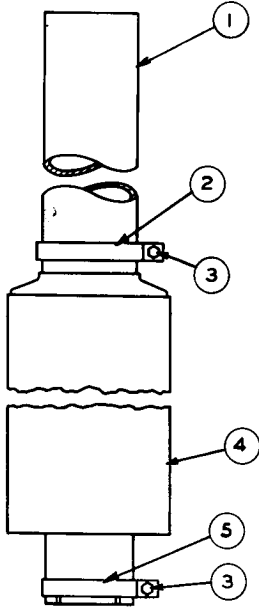

REF NO.	PART NUMBER	DESCRIPTION	QTY
1	9S1768	PIPE-----	1 C
2	6F8815	CLAMP-----	1
3	5S1591	BOLT-----	2
	1B5355	NUT-----	2
4	7S8443	MUFFLER-----	1
5	7H4266	CLAMP-----	1

126221

MUFFLER (7S6741 N/S)

Note: 7S1784 Rain Cap Assembly is available from Serial No. 11K5051 to 11K7034 inclusive

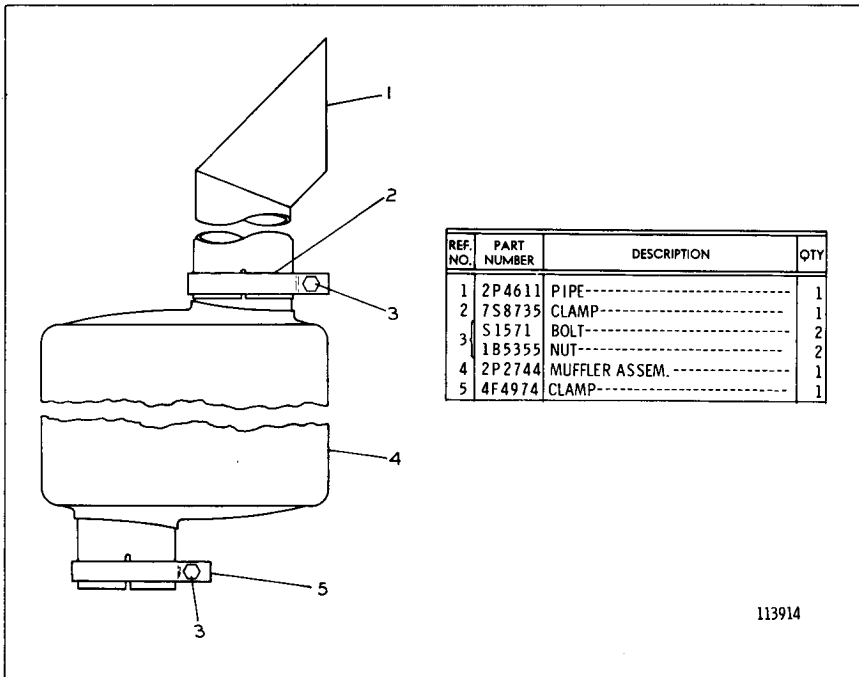

REF NO.	PART NUMBER	DESCRIPTION	QTY
1	2P4611	PIPE-----	1
2	7S8735	CLAMP-----	1
3	5S1571	BOLT-----	2
	1B5355	NUT-----	2
4	2P2744	MUFFLER ASSEM.-----	1
5	4F4974	CLAMP-----	1

113914

2P4609 MUFFLER GROUP

Part of 2P4859 Noise Suppression Arrangement listed on Page 21  
AN ATTACHMENT



CONSISTS OF:

- 4 4D3704 WASHER--REAR SUPPORT TO FRAME
- 2 7F5227 BOLT--FRONT SUPPORT ASSEMBLY TO FRAME
- 2 2J3506 NUT--FRONT SUPPORT ASSEMBLY TO FRAME
- 2 4K367 NUT--REAR SUPPORT TO FRAME
- 2 S1569 BOLT--REAR SUPPORT TO FRAME
- 2 2S115 WASHER--FRONT SUPPORT ASSEMBLY TO FRAME

ENGINE MOUNTING HARDWARE (4S6967 N/S)  
Serial No. 11K5051 to 11K6423 inclusive

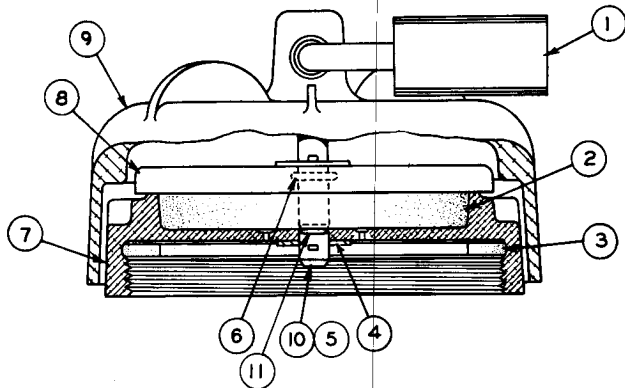

NOTE: FOR SERVICE OF PADLOCK AND KEY  
ORDER 8S7949 PADLOCK GROUP

▲ NOT PART OF 1P8678 CAP GROUP

REF. NO.	PART NUMBER	DESCRIPTION	QTY
▲ 1	Not Serv 8M439	PADLOCK-----	1
2	5S7657	KEY----- (Not Shown)	2
3	2A1763	FILTER-----	1
4	4J1105	GASKET-----	1
		SHIM-----	2

5	3B4605	COTTER PIN-----	2
6	5F9144	SEAL-----	1
7	1P8680	CAP-----	1
8	5S7646	LID-----	1
9	1P8050	COVER ASSEM.-----	1
	1P8052	RETAINER-----	1
10	1P8679	PIN-----	1
11	8F9538	SEAL-----	1

111574

1P8678 PROTECTION COVER GROUP—Fuel Tank Cap  
Part of 2P5300 and 3P7735 Vandalism Protection Arrangements listed  
on Page 227. AN ATTACHMENT

## CONSISTS OF:

- |   |        |   |
|---|--------|---|
| 4 | 1A458  | BOLT--REAR SUPPORT TO FRAME             |
| 2 | 7F5227 | BOLT--FRONT SUPPORT ASSEMBLY TO FRAME   |
| 2 | 2J3506 | NUT--FRONT SUPPORT ASSEMBLY TO FRAME    |
| 2 | 2S115  | WASHER--FRONT SUPPORT ASSEMBLY TO FRAME |

ENGINE MOUNTING HARDWARE (4S6967 N/S)  
Serial No. 11K6424—Up

FUEL TANK (3P2435 N/S)—102 U.S. Gallon  
Serial No. 11K5061 to 11K6440 Inclusive

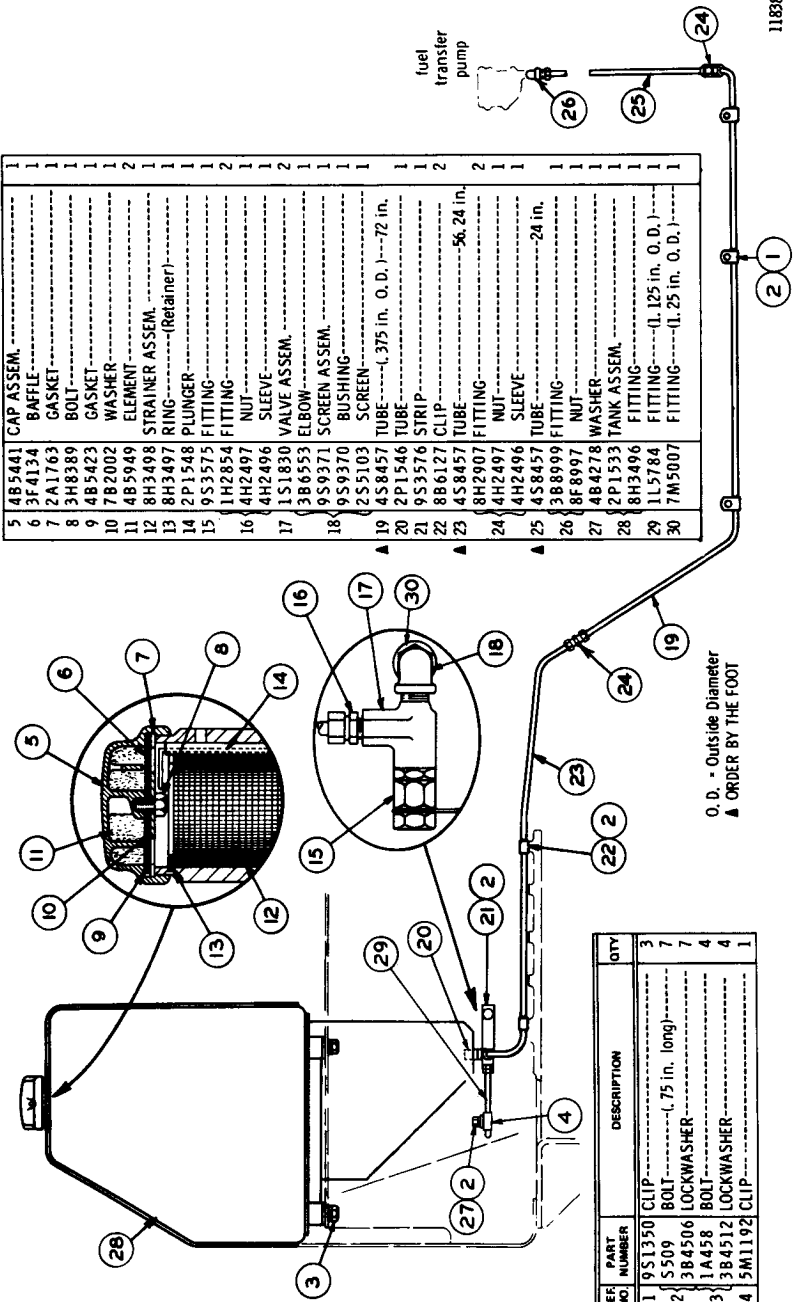

O. D. - Outside Diameter  
▲ ORDER BY THE FOOT

5	4B5441	CAP ASSEM.	1
6	3F4134	BAFFLE	1
7	2A1763	GASKET	1
8	3H8389	BOLT	1
9	4B5423	GASKET	1
10	7B2002	WASHER	1
11	4B5949	ELEMENT	2
12	8H3498	STRAINER ASSEM.	1
13	8H3497	RING—(Retainer)	1
14	2P1548	PLUNGER	1
15	9S5575	FITTING	1
16	1H2854	FITTING	2
16	4H2497	NUT	1
17	4H2496	SLEEVE	1
17	1S1830	VALVE ASSEM.	2
17	3B6553	ELBOW	1
18	9S9371	SCREEN ASSEM.	1
18	9S9370	BUSHING	1
18	2S5103	SCREEN	1
19	4S8457	TUBE—(, 375 in. O. D.)—72 in.	1
20	2P1546	TUBE	1
21	9S3576	STRIP	1
22	8B6127	CLIP	2
23	4S8457	TUBE—56.24 in.	2
24	8H2907	FITTING	2
24	4H2497	NUT	1
24	4H2496	SLEEVE	1
25	4S8457	TUBE—24 in.	1
26	3B8999	FITTING	1
26	8F8997	NUT	1
27	4B4278	WASHER	1
27	2P1533	TANK ASSEM.	1
28	8H5496	FITTING—(1.125 in. O. D.)	1
29	1L5784	FITTING—(1.25 in. O. D.)	1
30	7M5007	FITTING	1

REF. NO.	PART NUMBER	DESCRIPTION	QTY.
1	9S1330	CLIP	3
2	5509	BOLT—(, 75 in. long)	7
3	3B4506	LOCKWASHER	4
4	1A458	BOLT	4
4	3B4512	LOCKWASHER	4
4	15M1192	CLIP	1

118886

CATERPILLAR 977L TRAXCAVATOR

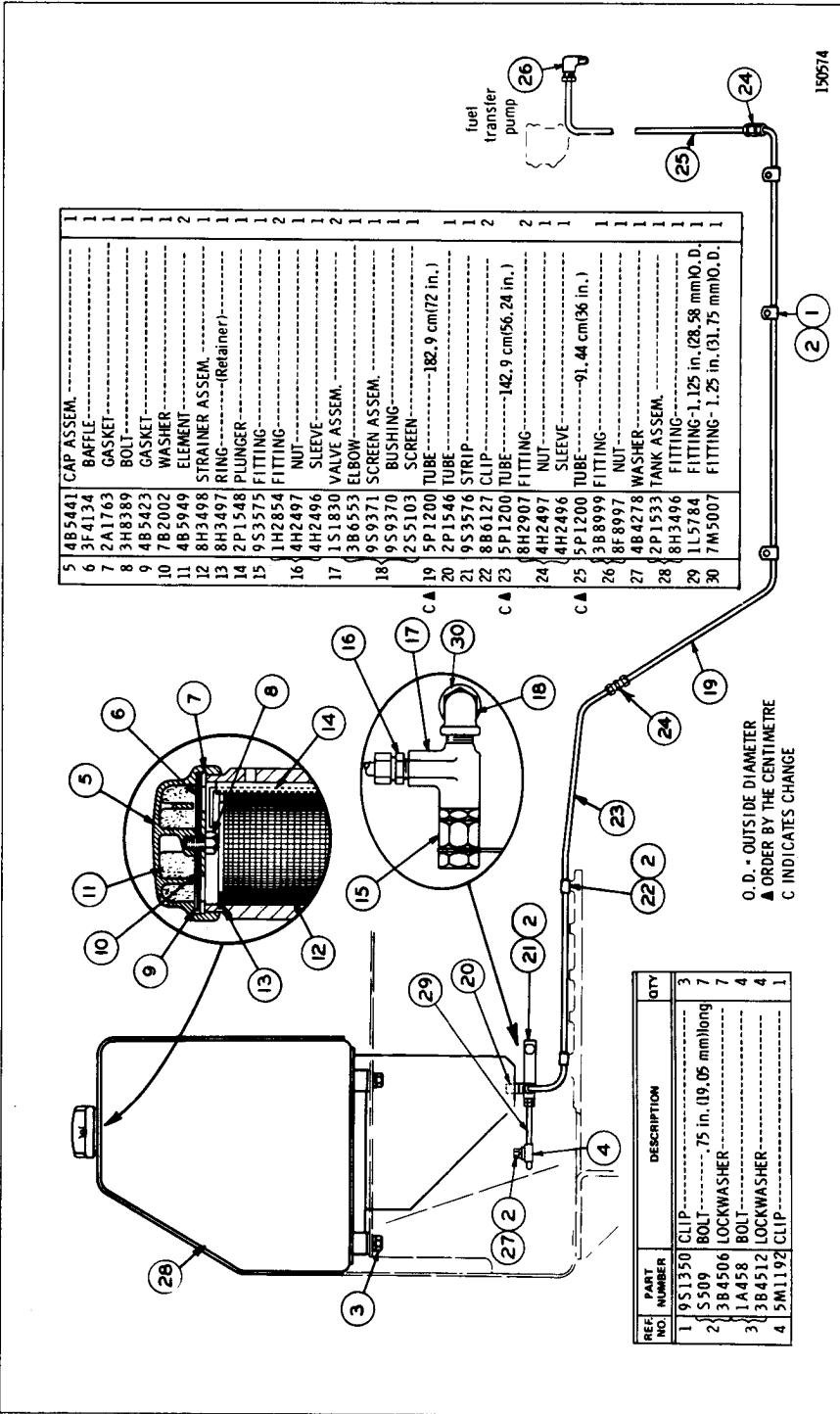

1	4B5441	CAP ASSEM.	1
6	3F4134	BAFFLE	1
7	2A1763	GASKET	1
8	3H8389	BOLT	1
9	4B5423	GASKET	1
10	7B2002	WASHER	1
11	4B5949	ELEMENT	2
12	8H3498	STRAINER ASSEM.	1
13	8H3497	RING (Retainer)	1
14	2P1548	PLUNGER	1
15	9S3575	FITTING	1
15	1H2854	FITTING	2
16	4H2497	NUT	1
16	4H2496	SLEEVE	1
17	1S1830	VALVE ASSEM.	2
17	3B6553	ELBOW	1
18	9S9371	SCREEN ASSEM.	1
18	9S9370	BUSHING	1
18	2S5103	SCREEN	1
19	5P1200	TUBE	1
19	2P1546	TUBE	1
20	2P1546	TUBE	1
21	9S3576	STRIP	1
22	8B6127	CLIP	2
23	5P1200	TUBE	2
23	8H2907	FITTING	2
24	4H2497	NUT	1
24	4H2496	SLEEVE	1
25	5P1200	TUBE	1
25	3B8909	FITTING	1
26	8E8997	NUT	1
27	4B4278	WASHER	1
28	2P1533	TANK ASSEM.	1
28	8H3496	FITTING	1
29	1L5784	FITTING-1.125 in. (28.58 mm) O. D.	1
30	7M5007	FITTING-1.25 in. (31.75 mm) O. D.	1

REF. NO.	PART NUMBER	DESCRIPTION	QTY
1	9S1350	CLIP	3
2	S509	BOLT-.75 in. (19.05 mm) long	7
3	3B4506	LOCKWASHER	4
3	1A458	BOLT	7
3	3B4512	LOCKWASHER	4
4	5M1192	CLIP	1

O. D. - OUTSIDE DIAMETER  
 ▲ ORDER BY THE CENTIMETRE  
 C INDICATES CHANGE

FUEL TANK (3P2435 N/S)—102 U.S. Gallons  
 Serial No. 11K6441—Up

150574

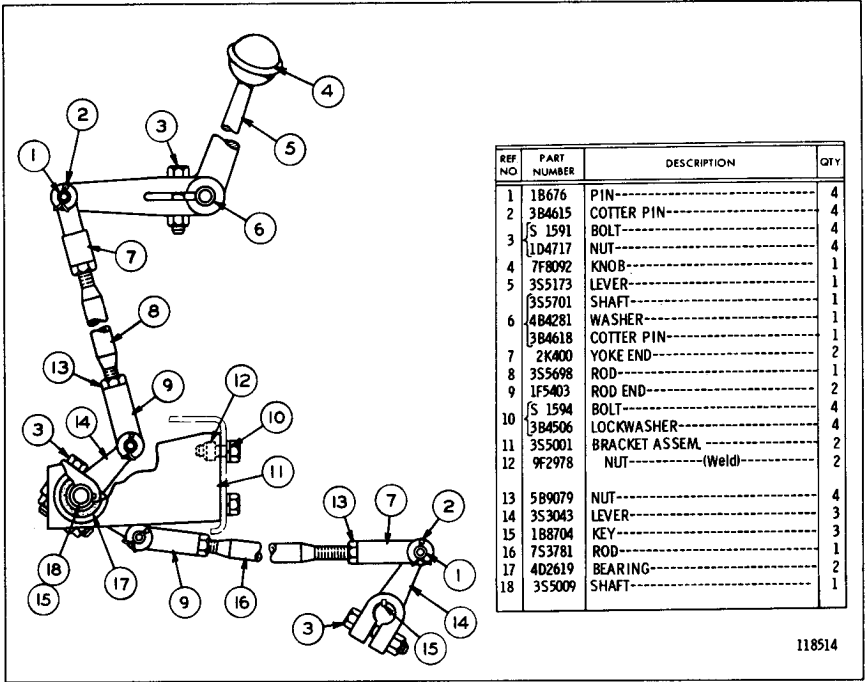

GOVERNOR CONTROL (3P2431 N/S)  
Serial No. 11K5051 to 11K6440 inclusive

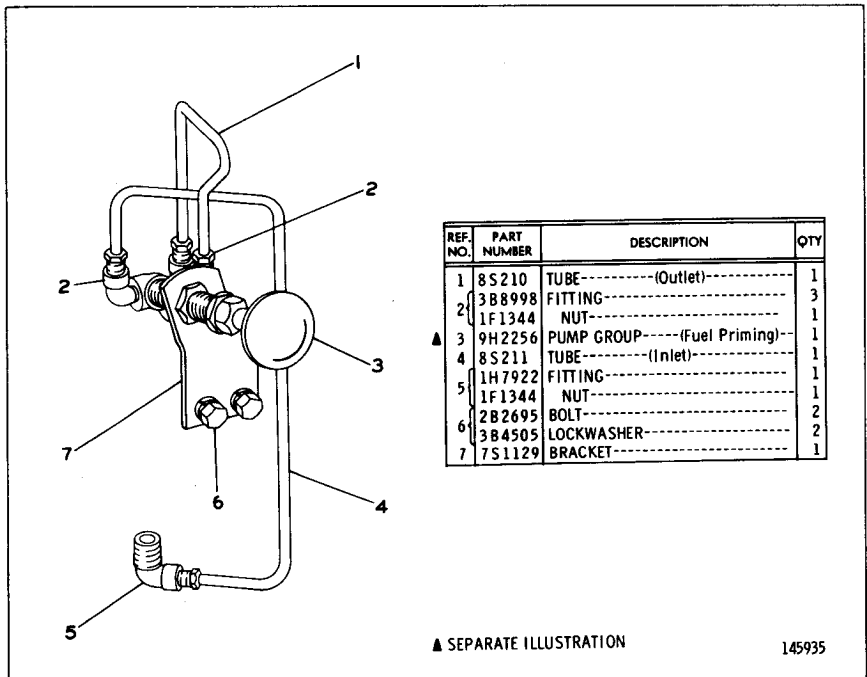

7S1251 FUEL PRIMING PUMP GROUP  
Serial No. 11K5051 to 11K6440 inclusive. Part of 4N6393 Refrigerant Compressor Arrangement listed on Page 233. 9H2256 Pump parts are shown on Page 25B. AN ATTACHMENT

REF. NO.	PART NUMBER	DESCRIPTION	QTY
1	1F5403	ROD END	1
2	3S5698	ROD	1
3	5B9079	NUT	1
4	2K400	END	4
5	1B676	PIN	4
6	3B4615	COTTER PIN	4
7	51591	BOLT	3
8	1D4717	NUT	1
9	3S5173	LEVER	1
10	7F8092	KNOB	1
11	3S5701	SHAFT	1
12	9A484281	WASHER	1
13	3B4618	COTTER PIN	1
14	4L6454	BOLT	1
15	3B4506	LOCKWASHER	2
16	15		1
17	14		1
18	16		1
19	18-11		1
20	19-13		1
21	20-11-18		1
22	21		1
23	22		1
24	23		1
25	24-35		1
26	25		1
27	26		1
28	27		1
29	28		1
30	29		1
31	30		1
32	31		1
33	32		1
34	33		1
35	34		1
36	35		1

12	7B8167	BOLT	4
13	4N5287	SHIM	1
14	6P2201	BRACKET ASSEM. (Includes)	1
15	9F2978	NUT	2
16	8H9182	ROLLER	1
17	6P2269	SHAFT ASSEM. (Includes)	1
18	2S6079	KEY	1
19	51594	BOLT	4
20	3S5001	BRACKET ASSEM. (Each Includes)	2
21	9F2978	NUT	2
22	3S3043	LEVER	2
23	188704	KEY	2
24	4D2619	BEARING	2
25	8H9186	SPRING	2
26	6P2256	RING	2
27	7M6955	GASKET	2
28	7M2167	RING	1
29	9S4671	SEAL	2
30	6P2271	SHAFT ASSEM. (Includes)	1
31	1A9252	END	1
32	6M8605	LEVER	1
33	9F7022	BOLT	1
34	1B4330	NUT	1
35	6P2206	ROD ASSEM. (Includes)	1
36	6P2207	ROD	1
37	5B9079	NUT	1
38	1F5403	ROD END	1
39	9S2308	GASKET	1

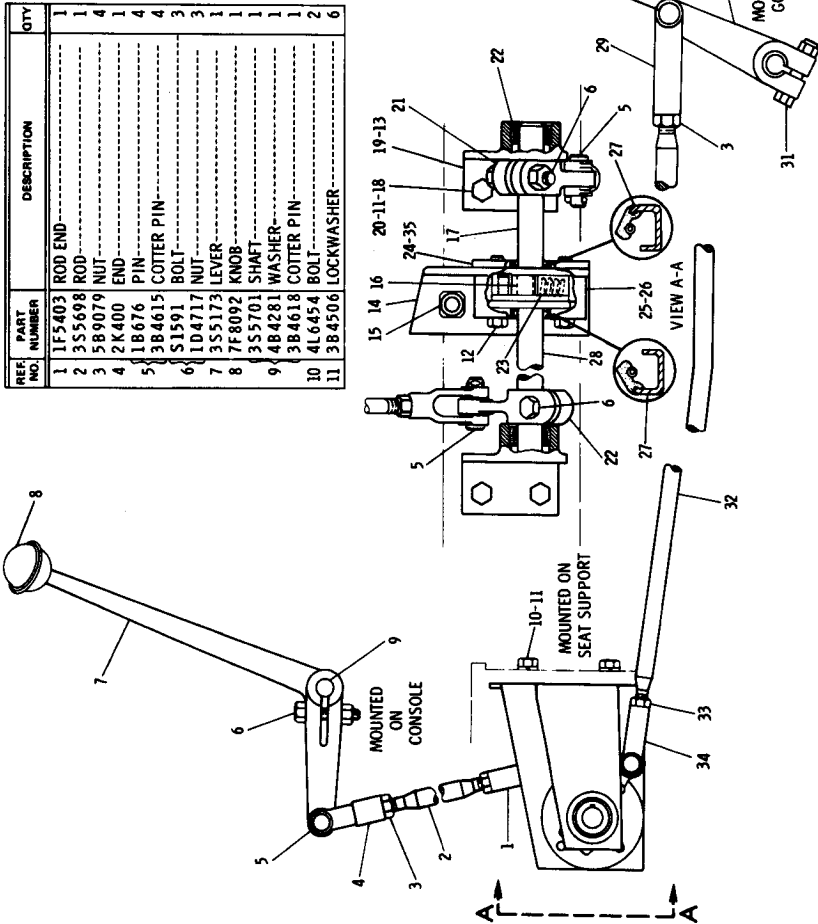

C INDICATES CHANGE  
152636

GVERNOR CONTROL (6P2272 N/S)  
Serial No. 11K6441—Up

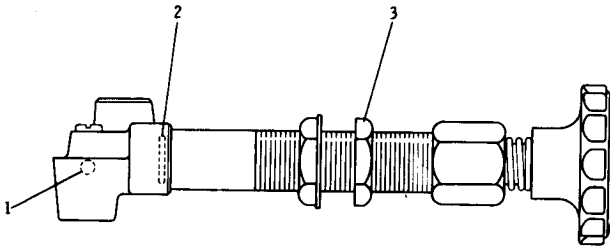

REF. NO.	PART NUMBER	DESCRIPTION	QTY
1	1M6718	BALL-----	2
2	1H1023	SEAL-----	2
C 3	1M6781	NUT-----	2

C INDICATES CHANGE

147588

9H2256 PUMP GROUP  
Part of 7S1251 Fuel Priming Pump Group shown on Page 25

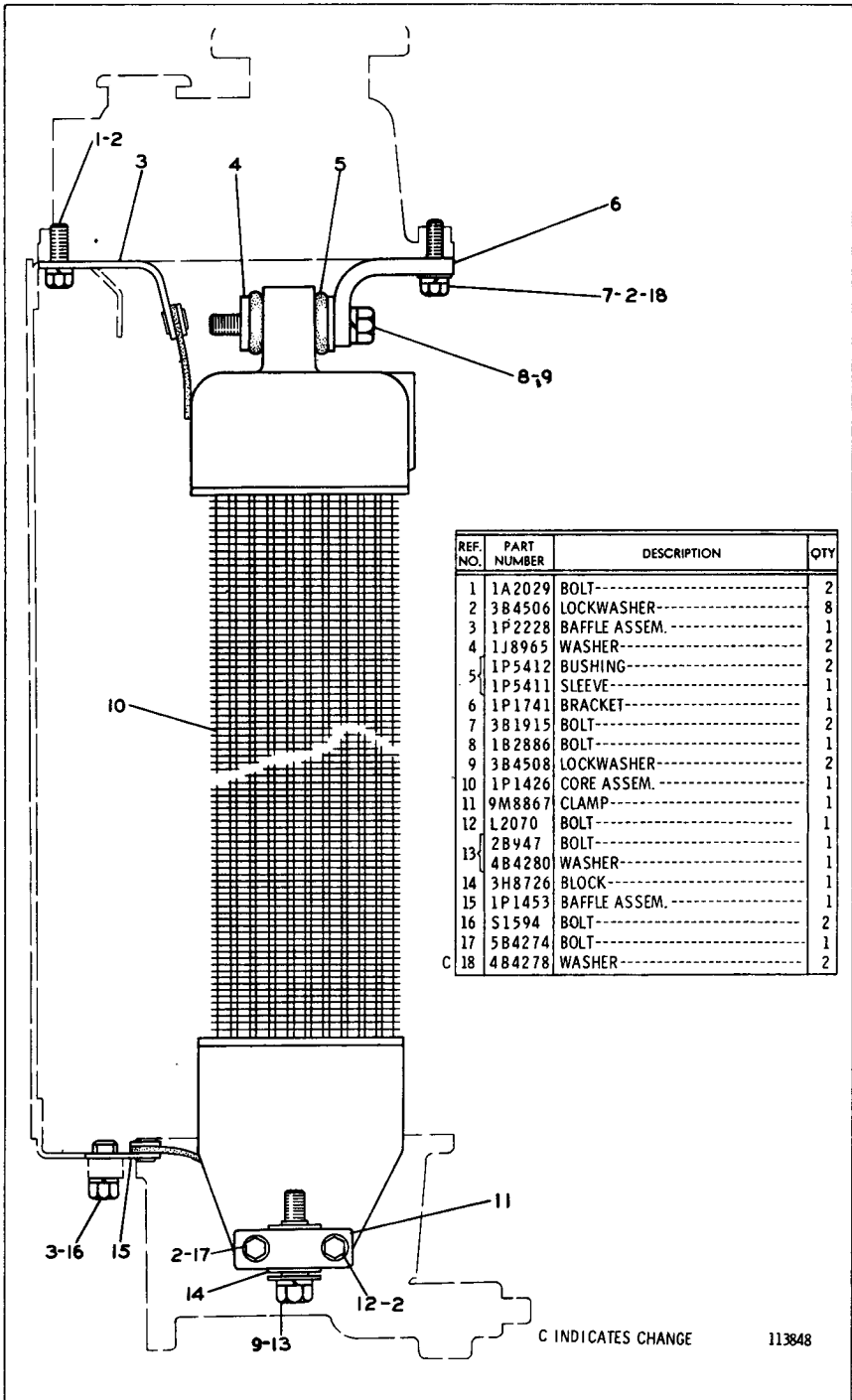

C INDICATES CHANGE

113848

TORQUE CONVERTER & HYDRAULIC OIL COOLER (1P2444 N/S)



2P7209 HIGH-SPEED OIL CHANGE GROUP  
AN ATTACHMENT

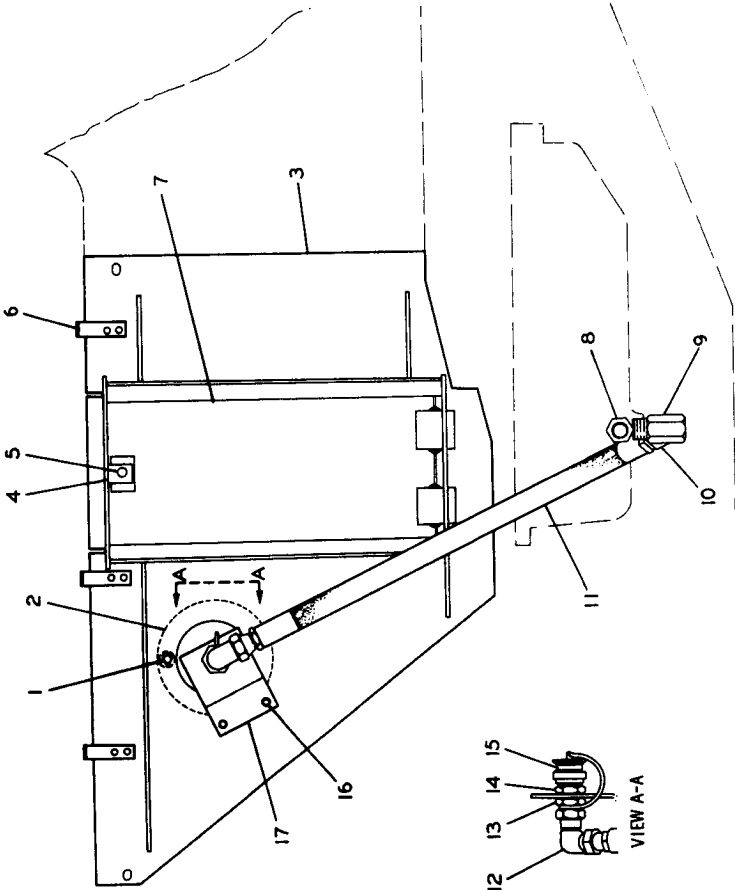

REF. NO.	PART NUMBER	DESCRIPTION	QTY
	6B1225	PIN-----	1
1	3B4614	COTTER PIN-----	1
	4B4278	WASHER-----	1
	4B7033	SPRING-----	1
2	2P7208	COVER-----	1
3	2P7205	PLATE ASSEM.-----	1
4	2M473	LUG-----	1
	S1621	BOLT-----	1
5	3B4508	LOCKWASHER-----	1
	4B4280	WASHER-----	1
	4S9370	PLATE-----2.69" long)	3
6	4S9369	PLATE-----1.38" long)	3
	4B4314	RIVET-----	6
7	8S3077	PLATE ASSEM.-----	1
	4B6190	PLUG-----	1
8	4B8406	GASKET-----	1
9	2H9399	UNION-----	1
10	6H8297	UNION-----	1
11	2P7207	HOSE ASSEM. --28" long overall)--	1
12	3R9704	ELBOW-----	1
13	6K8420	NUT-----	1
14	1P7919	COUPLER-----	1
15	9S9272	CAP ASSEM.-----	1
16	S1594	BOLT-----	2
17	2P7206	BRACKET-----	1

113907

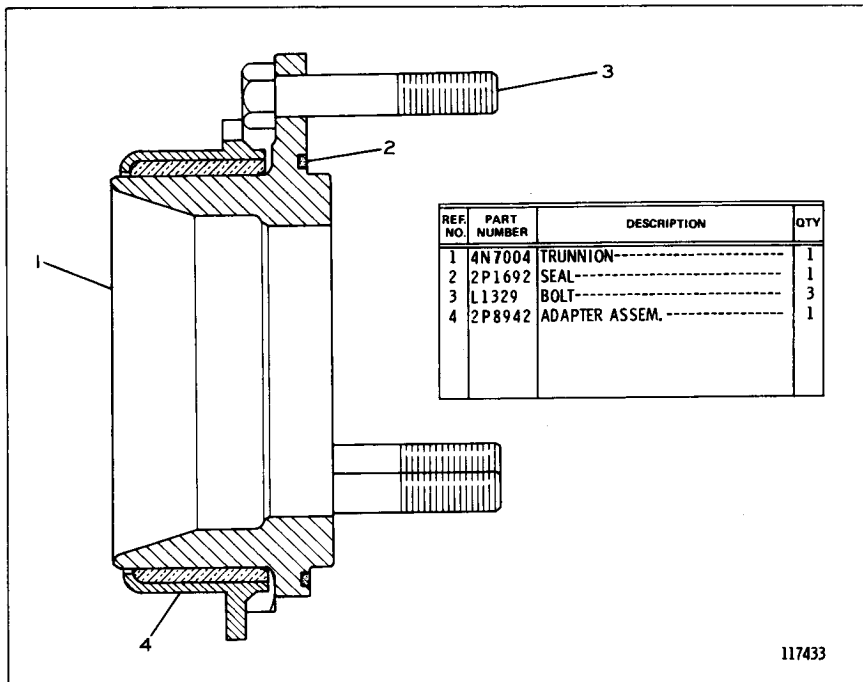

117433

**2P8943 TRUNNION GROUP**

Part of 1P9409 Steel Mill Traxcavator Arrangement listed on Page 104  
AN ATTACHMENT

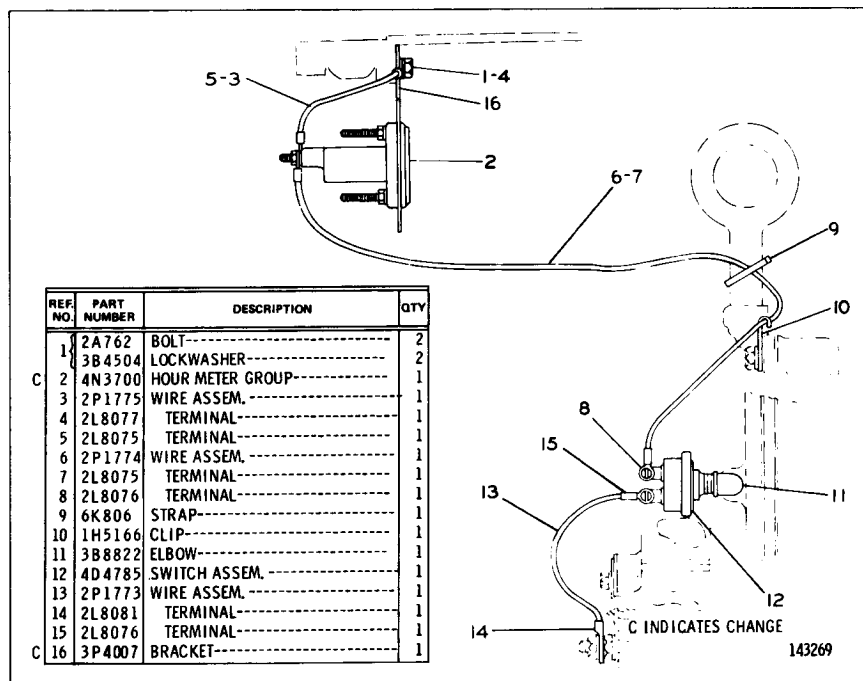

143269

**2P8374 ELECTRIC HOUR METER GROUP**

Serial No. 11K5051 to 11K6041 inclusive

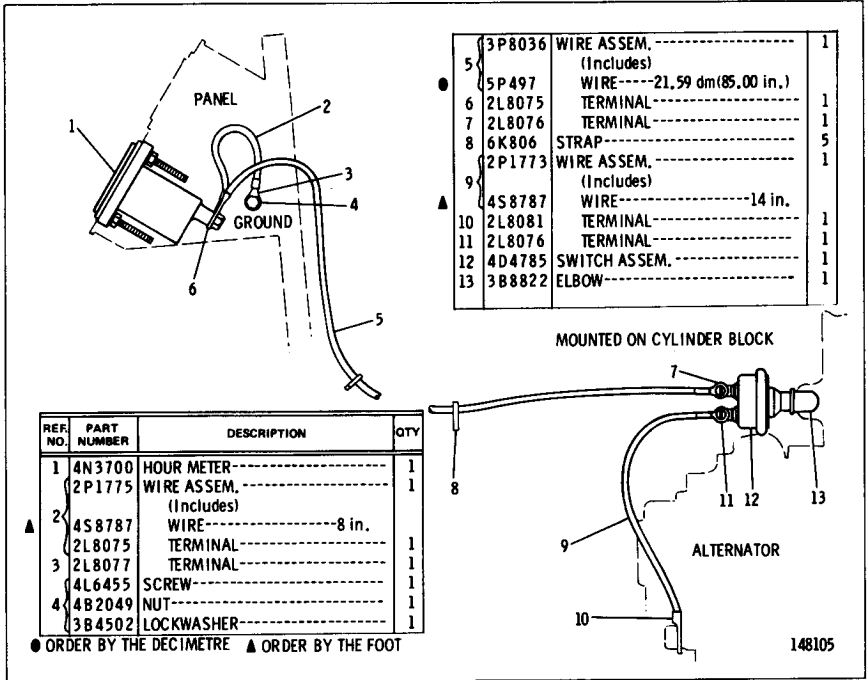

ELECTRIC HOUR METER (3P8037 N/S)  
Serial No. 11K6042—Up

WIRING DIAGRAM—24 Volt System

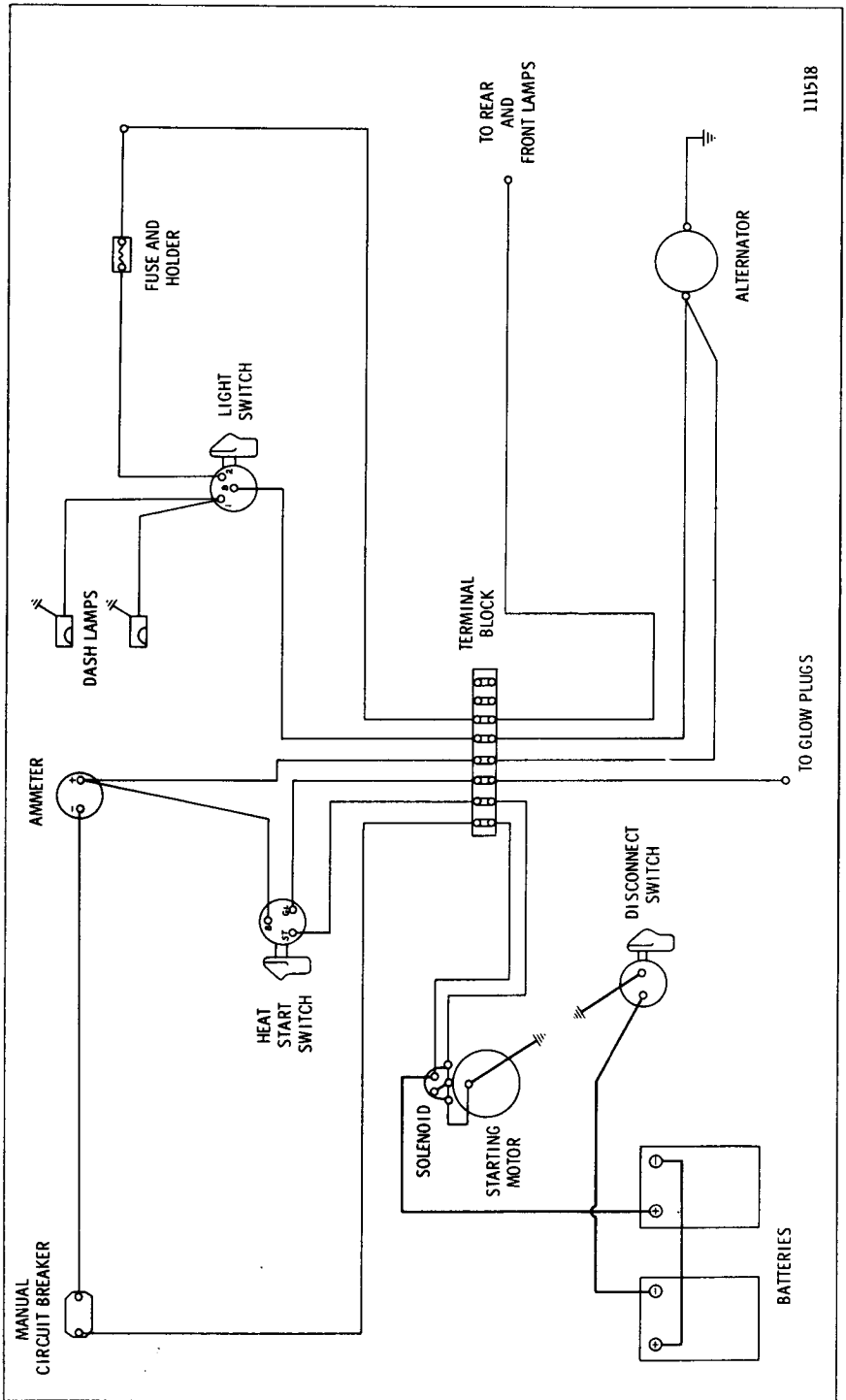

111518

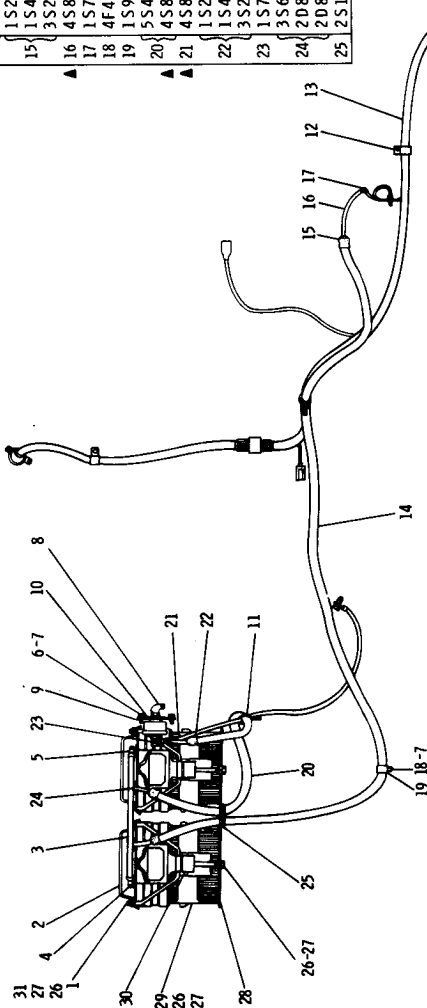

REF NO.	PART NUMBER	DESCRIPTION	QTY
1	2S1686	1/2" BOLT	4
1	9H8524	NUT	8
2	4B4278	WASHER	2
2	5S128	HOLDDOWN	2
3	5S131	CABLE ASSEM.	1
3	4S8783	CABLE-----16 in.	1
4	3S6050	TERMINAL ASSEM.	1
4	2D8788	BOLT	1
5	2D8787	NUT	1
5	3S6049	TERMINAL ASSEM.	1
5	2D8788	BOLT	1
5	2D8787	NUT	1

6	1102	BOLT	2
7	3B4506	LOCKWASHER	3
8	7H7290	SWITCH	1
8	7H7290	SWITCH	1
9	3S7007	PLATE	1
9	3S7007	PLATE	1
10	8H8648	PLATE	1
10	8H8648	PLATE	1
11	L1325	WASHER	2
11	L1325	WASHER	2
C 12	8M2770	CLIP	2
C 13	2P2631	HARNES ASSEM.	1
C 13	2P2631	HARNES ASSEM.	1

C INDICATES CHANGE  
C (Separate Illustration)

14	1S969	CABLE ASSEM.	1
14	4S8732	CONDUIT-----107 in.	1
2	1S2244	ROOT	2
2	1S4915	LINER	2
15	3S2093	TIE	2
16	4S8783	CABLE-----115 in.	1
17	1S7251	TERMINAL	1
18	4F4879	BOLT	1
19	1S994	CLIP	1
19	1S994	CLIP	1
20	5S4783	CABLE ASSEM.	1
20	4S8783	CABLE-----46 in.	1
21	4S8732	CONDUIT-----35 in.	2
21	1S2244	ROOT	2
22	1S4915	LINER	2
22	3S2093	TIE	2
23	1S7252	TERMINAL	1
23	3S6050	TERMINAL ASSEM.	1
24	2D8788	BOLT	1
24	2D8787	NUT	1
25	1S1647	GROMMET	1

26	1D5117	NUT	6
27	3B4508	LOCKWASHER	4
28	8M4974	MAT	1
28	4S9261	BATTERY	2
29	5S8405	PLUG	6
30	5S129	CLIP ASSEM.	4
31	4B4280	WASHER	2

▲ ORDER BY THE FOOT  
1.63248

BATTERY AND WIRING (1P4784 N/S)—24 Volt—Top View—Part 1  
 Serial No. 11K5051 to 11K6041 inclusive  
 2P2631 Harness and 7H7290 Switch parts are shown on Pages 33 and 34  
 See Page 29 for Wiring Diagram

BATTERY AND WIRING (1P4784 N/S)—24 Volt—Top View—Part 2  
 Serial No. 11K5051 to 11K6041 Inclusive  
 8M7677, 9M1305 Lamp and 2P2632 Harness parts are shown on Pages 32 and 33  
 See Page 29 for Wiring Diagram

REF. NO.	PART NUMBER	DESCRIPTION	QTY
	481311	SCREW	2
1	482049	NUT	2
	384502	LOCKWASHER	2
2	9M1303	LAMP ASSEM.-----(R. H.) (Separate Illustration)	1

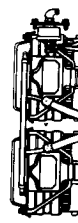
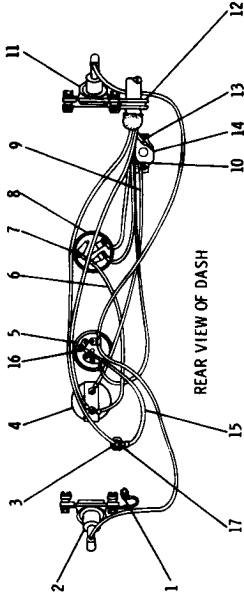

● TWO 5S1680 BOXES ARE REQUIRED TO MAKE A COMPLETE BOX  
 C INDICATES CHANGE

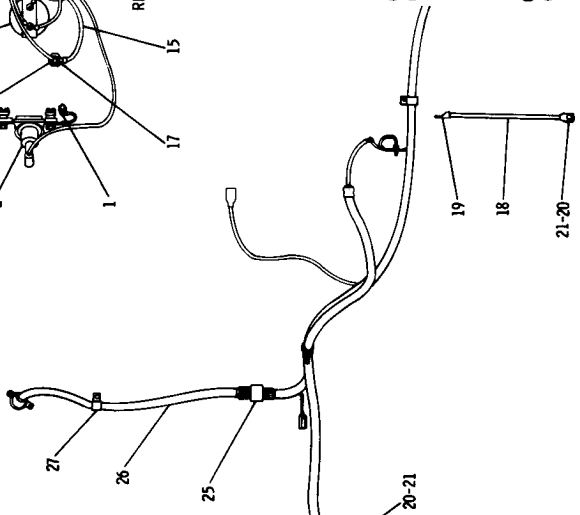

3	4K5122	HOLDER	1
4	8M8948	FUSE	1
5	1F7307	AMMETER	1
	7S6402	SWITCH-----(three position)	1
	7S5432	KNOB	1
6	5S4839	WIRE ASSEM.	1
7	7F9224	TERMINAL	2
	8S7713	SWITCH ASSEM.-----(heat-start)	1
8	8E3437	LEVER	1
	5L7200	SCREW	1
9	3B4501	LOCKWASHER	1
10	5S4838	WIRE ASSEM.	1
	1F7240	TERMINAL	2
11	8M7677	LAMP ASSEM.-----(L. H.) (Separate Illustration)	1

12	1M4543	GROMMET	1
13	5M6668	SCREW	2
14	5M2555	CIRCUIT BREAKER	1
15	1F7187	WIRE ASSEM.	1
16	2L8066	TERMINAL	1
17	6K9704	TERMINAL	1

18	5K7088	CABLE ASSEM.	1
19	2M912	TERMINAL	2
C 20	S 509	BOLT	2
C 21	384506	LOCKWASHER	2
22	4D2775	CABLE ASSEM.	1
	2M912	TERMINAL	1
23	2M913	TERMINAL	1
● 25	5S1680	BOX	1
C 26	2P2632	HARNESS ASSEM. (Separate Illustration)	1
C 27	8M2770	CLIP	1
	GMG0098	FORM (Instructions for installing Heat-Start Switch)	1

143249

14	15969	CABLE ASSEM.	1	
▲	458732	CONDUIT-----107 in.	1	
	152244	BOOT-----	2	
15	154915	LINER-----	2	
	352093	TIE-----	2	
▲	16	458783	CABLE-----115 in.	1
17	157251	TERMINAL-----	1	
18	4F4879	BOLT-----	1	
19	15994	CLIP-----	1	
▲	20	554783	CABLE ASSEM.	1
▲	21	458783	CABLE-----46 in.	2
▲	21	458732	CONDUIT-----35 in.	2
	152244	BOOT-----	2	
22	154915	LINER-----	2	
	352093	TIE-----	2	
23	157252	TERMINAL-----	1	
	356050	TERMINAL ASSEM.	1	
24	2D8788	BOLT-----	1	
	2D8787	NUT-----	1	
25	251647	GROMMET-----	1	

26	1D5117	NUT-----	6
27	3B4508	LOCKWASHER-----	4
28	8M4972	MAT-----	1
29	4S9261	BATTERY-----	2
30	558405	PLUG-----	6
31	55129	CLIP ASSEM.	4
	4B4280	WASHER-----	2

▲ ORDER BY THE FOOT 148107

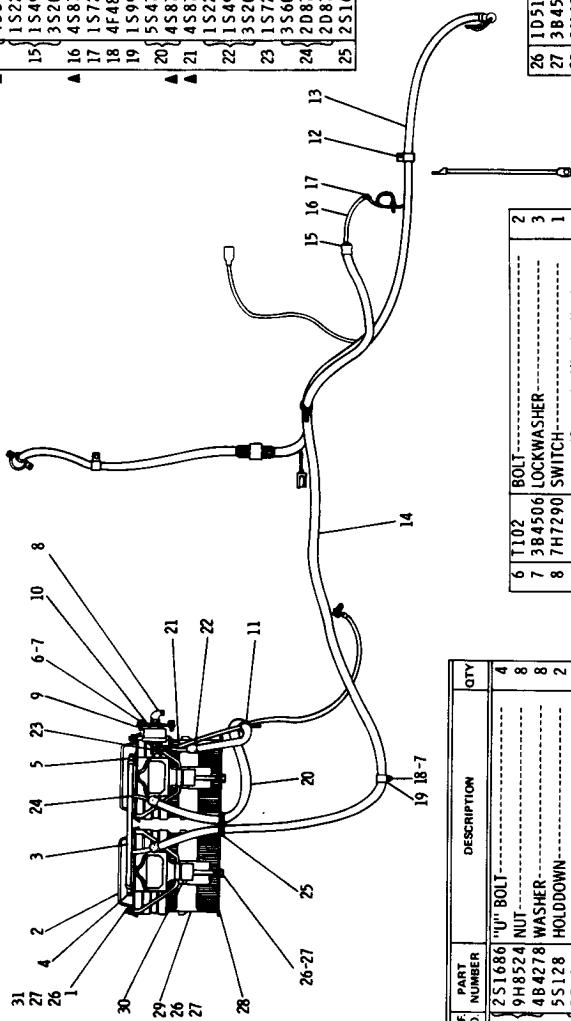

REF. NO.	PART NUMBER	DESCRIPTION	QTY.
1	251686	"U" BOLT-----	4
1	9H8524	NUT-----	8
1	4B4278	WASHER-----	8
2	55128	HOLDDOWN-----	2
3	55131	CABLE ASSEM.	1
3	458783	CABLE-----16 in.	1
4	356050	TERMINAL ASSEM.	1
4	2D8788	BOLT-----	1
5	2D8787	NUT-----	1
5	356049	TERMINAL ASSEM.	1
5	2D8788	BOLT-----	1
5	2D8787	NUT-----	1

6	1102	BOLT-----	2
7	3B4506	LOCKWASHER-----	3
8	7H7290	SWITCH-----	1
9	3S7007	PLATE-----	1
10	8H8648	PLATE-----	1
10	L1325	WASHER-----	1
11	153403	CLIP-----	2
12	8M2770	CLIP-----	2
13	2P2631	HARNES ASSEM.-----	1
		(Separate Illustration)	

BATTERY AND WIRING (1P4784 N/S)—24 Volt—Top View—Part 1  
 Serial No. 11K6042 to 11K6588 and 11K6592 to 11K6595 inclusive  
 2P2631 Harness and 7H7290 Switch parts are shown on Pages 33 and 34  
 See Page 29 for Wiring Diagram

BATTERY AND WIRING (1P4784 N/S)—24 Volt—Top View—Part 2  
 Serial No. 11K6042 to 11K6588 and 11K6592 to 11K6595 inclusive  
 8M7677, 9M1305 Lamp and 2P2632 Harness parts are shown on Pages 32 and 33  
 See Page 29 for Wiring Diagram

REF. NO.	PART NUMBER	DESCRIPTION	QTY
C	481311	SCREW	1
C	482049	NUT	1
C	384502	LOCKWASHER	1
C	9M1305	LAMP ASSEM. (R. H.)	1
		(Separate Illustration)	

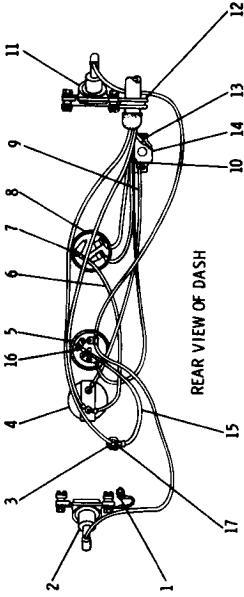
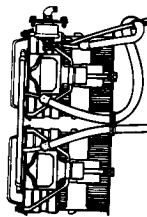

● TWO 5S1680 BOXES ARE REQUIRED TO MAKE A COMPLETE BOX

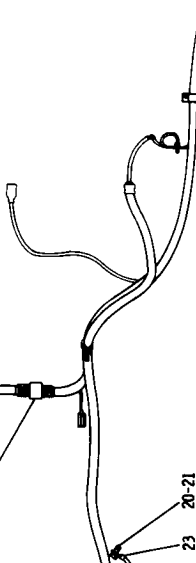

3	4K5122	HOLDER	1
4	8M8948	FUSE	1
4	1F7307	AMMETER	1
5	7S6402	SWITCH (three position)	1
5	7S5432	KNOB	1
6	5S4839	WIRE ASSEM.	1
7	7F9224	TERMINAL	1
7	8S7713	SWITCH ASSEM. (heat-start)	2
8	8F3437	LEVER	1
8	5L7200	SCREW	1
9	3B4501	LOCKWASHER	1
9	5S4838	WIRE ASSEM.	1
10	1F7240	TERMINAL	1
10	1F7240	TERMINAL (L. H.)	2
11	8M7677	LAMP ASSEM. (L. H.)	1
		(Separate Illustration)	

12	1M4543	GROMMET	1
13	5M6668	SCREW	2
14	5M2555	CIRCUIT BREAKER	1
15	1P7187	WIRE ASSEM.	1
16	2L8066	TERMINAL	1
17	6K9704	TERMINAL	1

18	5K7088	CABLE ASSEM.	1
19	2M912	TERMINAL	2
20	S509	BOLT	2
21	3B4506	LOCKWASHER	2
22	4D2775	CABLE ASSEM.	1
22	2M912	TERMINAL	1
23	2M913	TERMINAL	1
● 25	5S1680	BOX	1
26	2P2632	HARNESS ASSEM. (Separate Illustration)	1
27	8M2770	CLIP	1
	GMG00698	FORM (Instructions for installing Heat-Start Switch)	1

C INDICATES CHANGE

148108



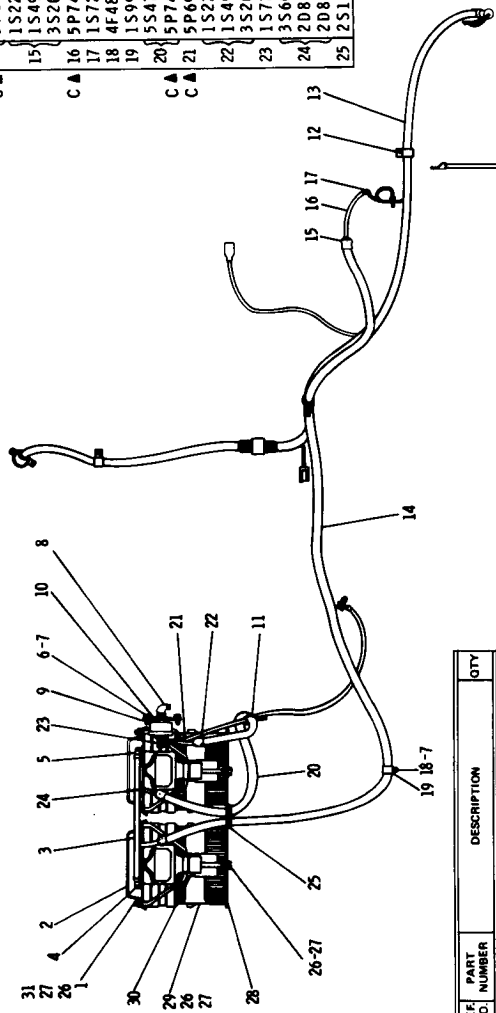

14	15969	CABLE ASSEM.	1
	5P695	CONDUIT---27.18 cm(107 in.)	1
	152244	BOOT	2
	154915	LINER	2
	352093	TIE	2
16	5P747	CABLE---29.21 cm(115 in.)	1
17	157251	TERMINAL	1
18	4F4879	BOLT	1
19	15994	CLIP	1
20	554783	CABLE ASSEM.	1
	5P747	CABLE---11.68 cm(46 in.)	2
	5P695	CONDUIT---8.89 cm(35 in.)	2
21	152244	BOOT	2
	154915	LINER	2
	352093	TIE	2
23	157252	TERMINAL	1
	356050	TERMINAL ASSEM.	1
24	2D8788	ROBT	1
	2D8787	NUT	1
25	2S1647	GROMMET	1

26	105117	NUT	6
27	3B4508	LOCKWASHER	4
28	8M4972	MAT	1
29	459261	BATTERY	2
	558405	PLUG	6
30	55129	CLIP ASSEM.	4
31	4B4280	WASHER	2

6	1102	BOLT	2
7	3B4506	LOCKWASHER	3
8	7H7290	SWITCH (Separate Illustration)	1
9	3S7007	PLATE	1
10	8H8648	PLATE	1
11	153403	CLIP	1
12	8M2770	CLIP	2
13	2P2631	HARNES ASSEM. (Separate Illustration)	2

REF. NO.	PART NUMBER	DESCRIPTION	QTY
1	2S1686	"U" BOLT	4
1	9H8524	NUT	8
2	4B4278	WASHER	8
2	55128	HOLDDOWN	2
3	55131	CABLE ASSEM.	1
3	5P747	CABLE---4.06 cm(16 in.)	1
4	3S6050	TERMINAL ASSEM.	1
4	2D8788	ROBT	1
4	2D8787	NUT	1
5	3S6049	TERMINAL ASSEM.	1
5	2D8788	ROBT	1
5	2D8787	NUT	1

▲ ORDER BY THE CENTIMETRE 151670

C INDICATES CHANGE

BATTERY AND WIRING (1P4784 N/S)—24 Volt—Top View—Part 1  
 Serial No. 11K6589 to 11K6591 and 11K6596—Up  
 2P2631 Harness and 7H7290 Switch parts are shown on Pages 33 and 34  
 See Page 29 for Wiring Diagram

BATTERY AND WIRING (1P4784 N/S)—24 Volt—Top View—Part 2  
 Serial No. 11K6589 to 11K6591 and 11K6596—Up  
 8M7677, 9M1305 Lamp and 2P2632 Harness parts are shown on Pages 32 and 33  
 See Page 29 for Wiring Diagram

REF. NO.	PART NUMBER	DESCRIPTION	QTY
1	4B1311	SCREW	1
1	4B2049	NUT	1
1	3B4502	LOCKWASHER	1
2	9M1305	LAMP ASSEM.---(R. H.)--- (Separate Illustration)	1

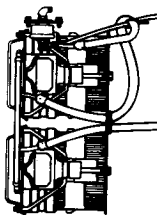

3	4K5122	HOLDER	1
4	8M8948	FUSE	1
4	8M7892	AMMETER	1
5	7S6402	SWITCH---(three position)	1
5	7S5432	KNOB	1
6	5S4839	WIRE ASSEM.	1
7	7F9224	TERMINAL	2
8	8S7713	SWITCH ASSEM.---(heat-start)	1
8	8F3437	LEVER	1
9	5L7200	SCREW	1
9	3B4501	LOCKWASHER	1
9	5S4838	WIRE ASSEM.	1
10	1F7240	TERMINAL	2
11	8M7677	LAMP ASSEM.---(L. H.)--- (Separate Illustration)	1

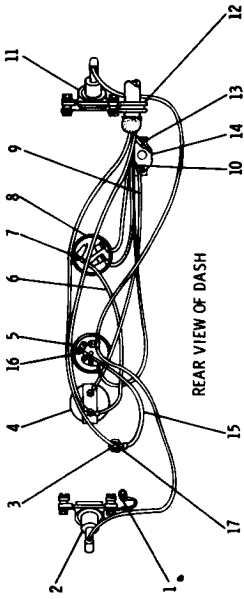

REAR VIEW OF DASH

● TWO 5S1680 BOXES ARE REQUIRED TO MAKE A COMPLETE BOX

18	5K7088	CABLE ASSEM.	1
19	2M912	TERMINAL	2
20	5S09	BOLT	2
21	3B4506	LOCKWASHER	2
22	4D2775	CABLE ASSEM.	1
23	2M912	TERMINAL	1
23	2M913	TERMINAL	1
25	5S1680	BOX	1
26	2P2632	HARNESS ASSEM.--- (Separate Illustration)	1
27	8M2770	CLIP	1
	GMG00698	FORM (Instructions for installing Heat-Start Switch)	1

C INDICATES CHANGE 151665

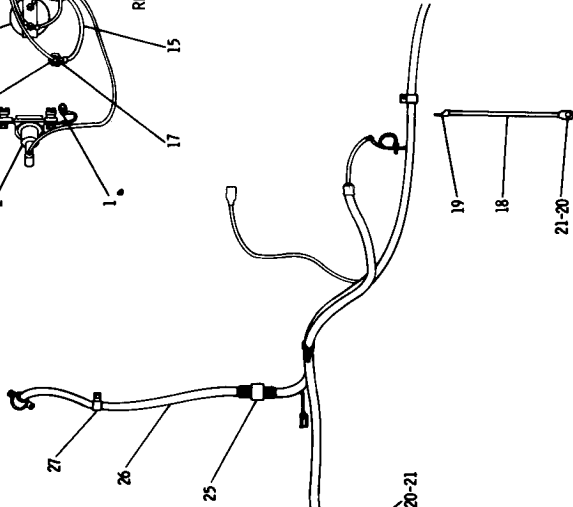

12	1M4543	GROMMET	1
13	5M6668	SCREW	2
14	9S173	CIRCUIT BREAKER	1
15	1P1787	WIRE ASSEM.	1
16	2L8066	TERMINAL	1
17	6K9704	TERMINAL	1

C 14

C

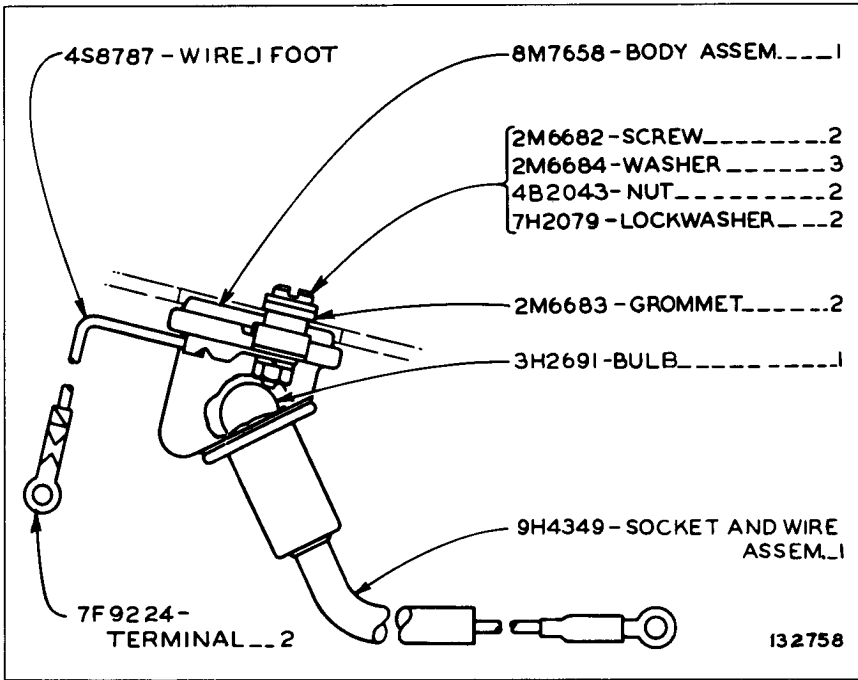

8M7677 DASH LAMP ASSEMBLY—24 Volt  
Part of Battery and Wiring shown on Page 31

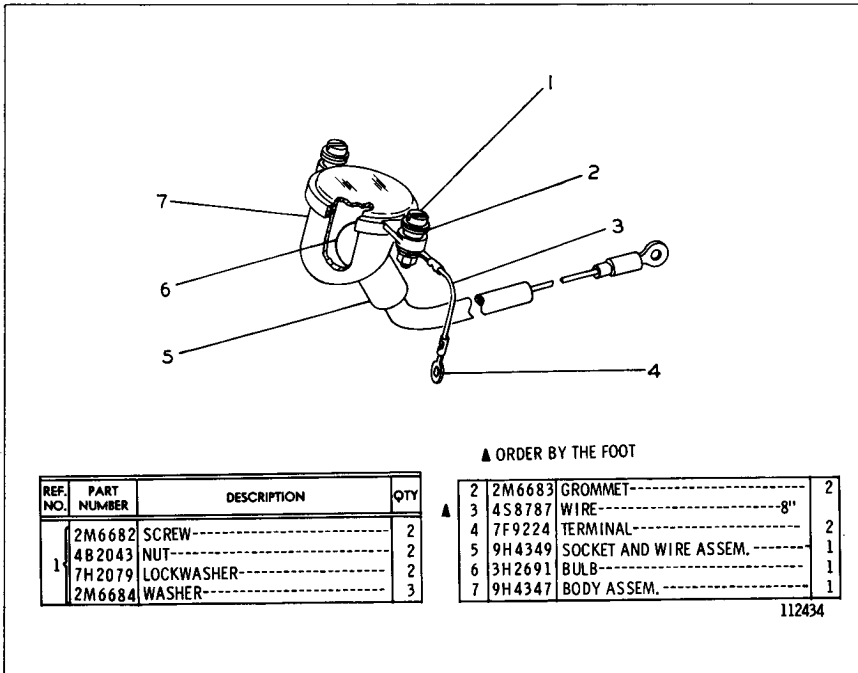

9M1305 DASH LAMP ASSEMBLY—24 Volt  
Part of Battery and Wiring shown on Page 31

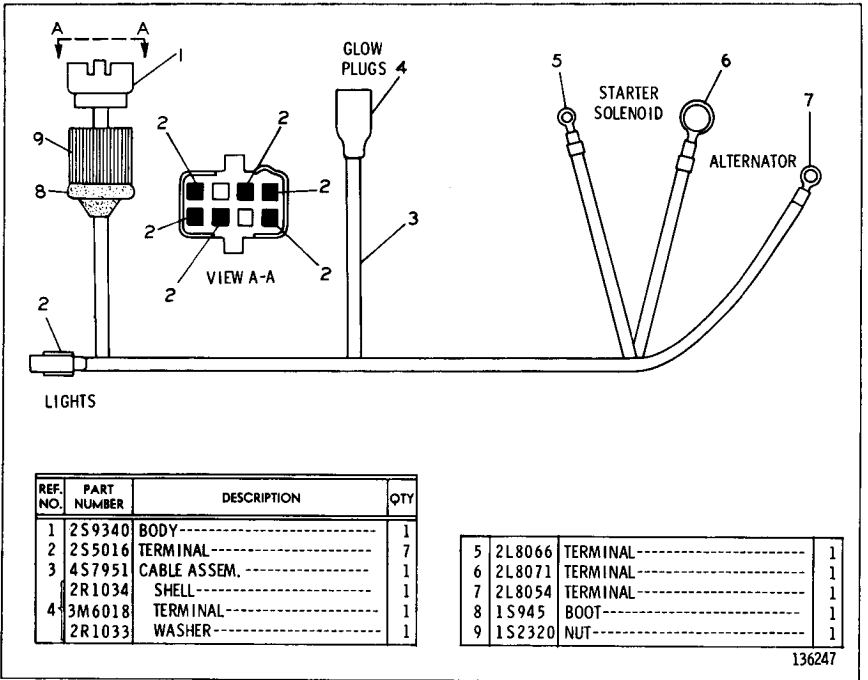

2P2631 HARNESS ASSEMBLY  
Part of Battery and Wiring shown on Page 30

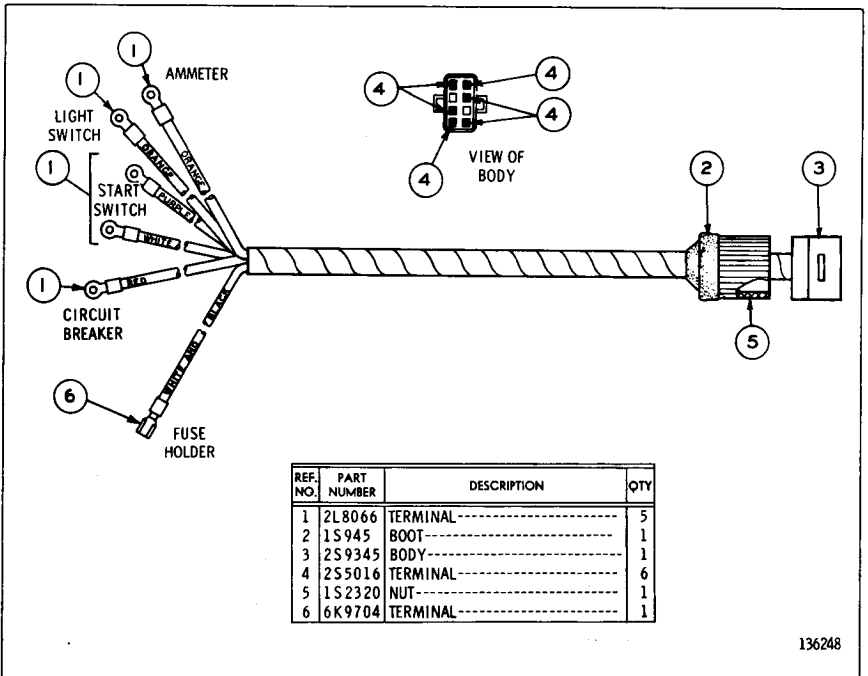

2P2632 HARNESS ASSEMBLY  
Part of Battery and Wiring shown on Page 31

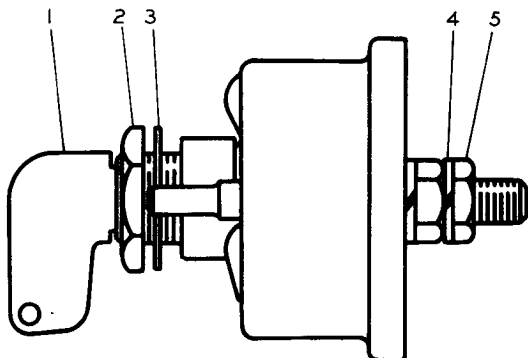

REF. NO.	PART NUMBER	DESCRIPTION	QTY
1	8H5306	KEY-----	1
2	8H5303	NUT-----	1
3	2H3922	LOCKWASHER-----	1
4	7F7259	LOCKWASHER-----	4
5	6F7045	NUT-----	4

112435

7H7290 DISCONNECT SWITCH ASSEMBLY  
Part of Battery and Wiring shown on Page 30

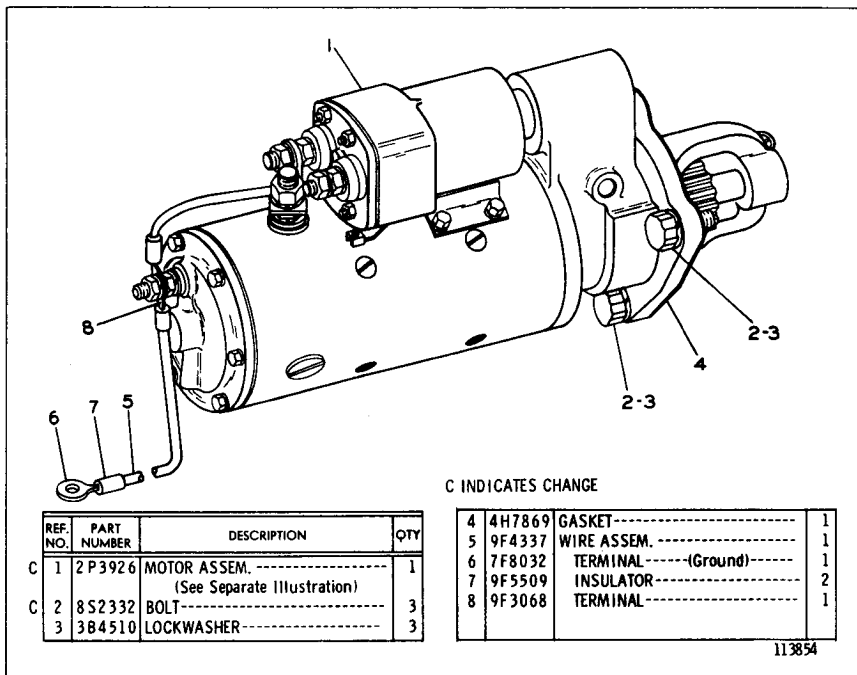

C INDICATES CHANGE

REF. NO.	PART NUMBER	DESCRIPTION	QTY
C 1	2P3926	MOTOR ASSEM.----- (See Separate Illustration)	1
C 2	8S2332	BOLT-----	3
3	3B4510	LOCKWASHER-----	3

4	4H7869	GASKET-----	1
5	9F4337	WIRE ASSEM.-----	1
6	7F8032	TERMINAL----- (Ground)	1
7	9F5509	INSULATOR-----	2
8	9F3068	TERMINAL-----	1

113854

8S3886 ELECTRIC STARTING MOTOR GROUP—24 Volt  
FOR USE IN TEMPERATURES OF 0° FAHRENHEIT OR BELOW  
AN ATTACHMENT

2F3926 STARTING MOTOR GROUP—24 Volt—Part 1 of 3  
 Part of 8S3886 Electric Starting Motor Group. 1P9181 Switch parts are shown on Page 40

REF. NO.	PART NUMBER	DESCRIPTION	QTY.
1	7F4556	BOLT	6
2	1L4789	LOCKWASHER	6
3	7M328	FRAME ASSEM.	1
4	7S9826	PLUG	1
5	7F3506	BUSHING	1
6	9F2247	PLUG	1
7	9F2547	WICK	1
8	7S9825	GASKET	1
9	7M8651	ARMATURE ASSEM.	1
10	3L3380	BUSHING	1
11	7M324	COIL ASSEM.	1
12	9H3757	WASHER	2
13	7F3494	WASHER	1
14	7M326	CONNECTOR	1
15	1D5117	NUT	2

1	SWITCH ASSEM.	1
17	6H3622 SCREW ASSEM. (See Separate Illustration)	4
18	3B4508 LOCKWASHER	12
19	9F9298 SCREW	1
20	7M325 INSULATOR	3
21	4M1831 PLUG	3
22	4M1832 GASKET	3
23	1H2629 STRIP	6
24	7F3488 SHOE	3
25	7M327	1

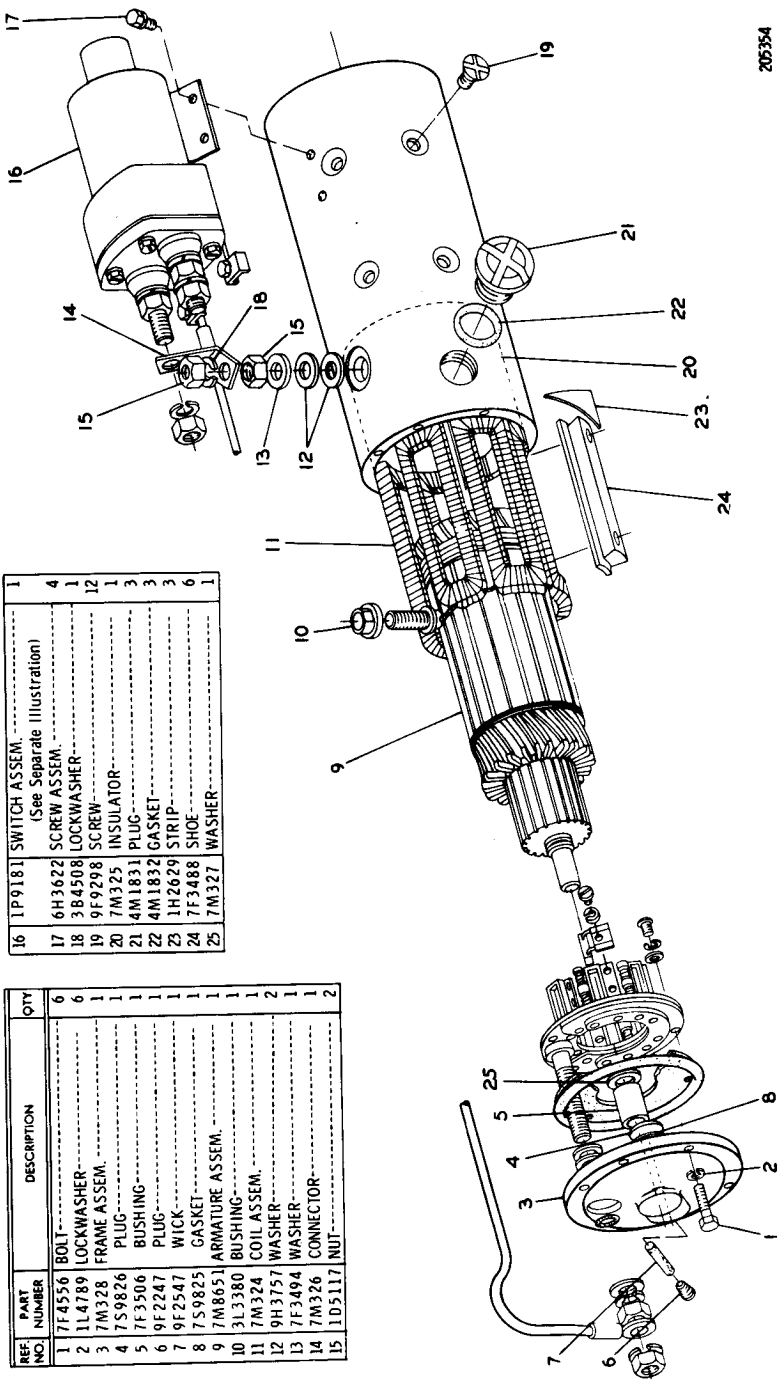

205354

REF. NO.	PART NUMBER	DESCRIPTION	QTY
1	4M1849	LEAD ASSEM.	1
2	2J8163	SEAL	3
3	7F3529	WASHER	3
4	8H878	LOCKWASHER	3
5	481221	SCREW	3
6	7M330	PLATE ASSEM.	1
7	7F3525	WASHER	12
8	7F3520	PLATE	1
9	5H6467	SCREW	3
10	7H2079	LOCKWASHER	12
11	2L6679	PLATE	3
12	7F3513	HOLDER	6
13	7F3522	SCREW	3
14	7F3512	SPRING	12
15	7M331	PLATE ASSEM.	1
16	7F3521	PLATE	3
17	7F7611	SCREW	3
18	7M332	PLATE	1
19	13H3697	SCREW	3

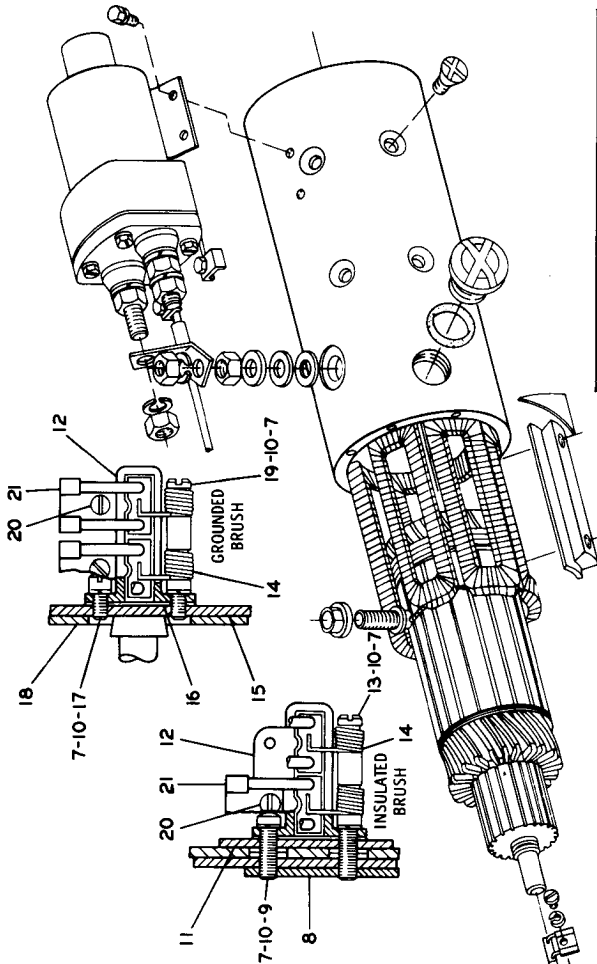

20	2F2860	SCREW---.312 in. (7.92 mm) long	12
21	3B4501	LOCKWASHER	12
21	7M329	BRUSH ASSEM.	12
22	7F3491	WASHER	2
23	8F9206	SEAL	1

C 24	6N3279	INSULATOR	1
25	1D4719	NUT	1
26	7F3494	WASHER	1
27	3B4508	LOCKWASHER	2
28	1D5117	NUT	1
THE FOLLOWING REPAIR KIT IS AVAILABLE:			
3N3763 KIT (terminal)			
3N3763 KIT (Includes Bushings, Insulator & Washer)			

205355

2P3926 STARTING MOTOR GROUP—24 Volt—Part 2 of 3  
Part of 8S3886 Electric Starting Motor Group shown on Page 34

2P3926 STARTING MOTOR GROUP—24 Volt—Part 3 of 3  
Part of 8S3886 Electric Starting Motor Group shown on Page 34

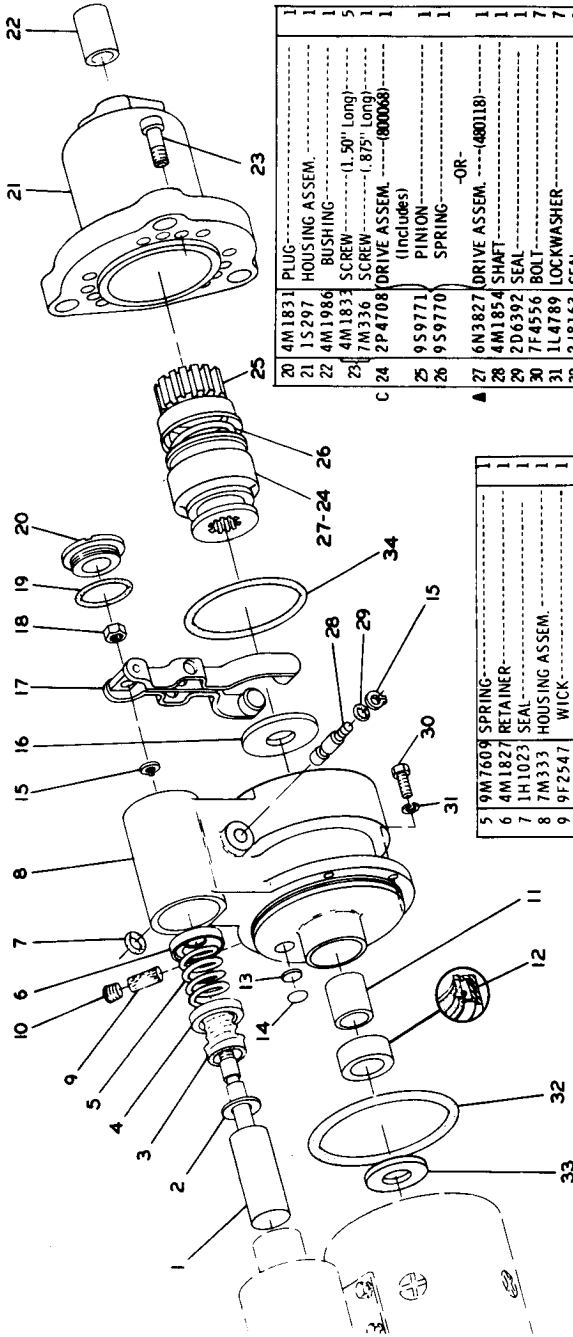

1	4M1831	PLUG	1
1	1S297	HOUSING ASSEM.	1
1	4M1986	BUSHING	1
5	4M1833	SCREW—(1.50" Long)	5
1	7M336	SCREW—(1.875" Long)	1
1	2P4708	DRIVE ASSEM.—(800068)	1
		(Includes)	
25	959771	PINION	1
26	959770	SPRING—OR—	1
		6N3827 DRIVE ASSEM.—(480118)	1
27	4M1854	SHAFT	1
28	2D6392	SEAL	1
29	7F4556	BOLT	7
30	1L4789	LOCKWASHER	7
31	218163	SEAL	7
32	1M9971	SPACER	1
33	4M1851	GASKET	1
34			1

1	9M7609	SPRING	1
1	4M1827	RETAINER	1
1	1H1023	SEAL	1
1	7M333	HOUSING ASSEM.	1
1	9F2547	WICK	1
1	9F2247	PLUG	1
1	2F6678	SEAL	1
1	1M9968	BUSHING	1
1	7S9826	PLUG	1
1	7S9825	GASKET	1
1	2H3429	RING	2
1	4L2729	WASHER	1
1	4M1853	LEVER ASSEM.	1
1	3F2617	NUT	1
1	4M1822	GASKET	1

REF. PART NO.	DESCRIPTION	QTY
1	4M1855 PLUNGER ASSEM.	1
1	FM059075 FORM—(Installation Instructions)	1
2	2S4027 WASHER	1
3	4M1829 BOOT	1
4	4M1828 RETAINER	1

THE FOLLOWING REPAIR KITS ARE AVAILABLE FOR 2P4708 DRIVE ASSEM.:

9S9825 KIT—(cup)  
 4S9459 KIT—(washer)  
 FM035152 FORM—(cup kit installation)  
 GM600012 FORM—  
 (Electric Starting Motor Changeover)

C INDICATES CHANGE 152733

▲ NOT PART OF 2P3926 STARTING MOTOR GROUP



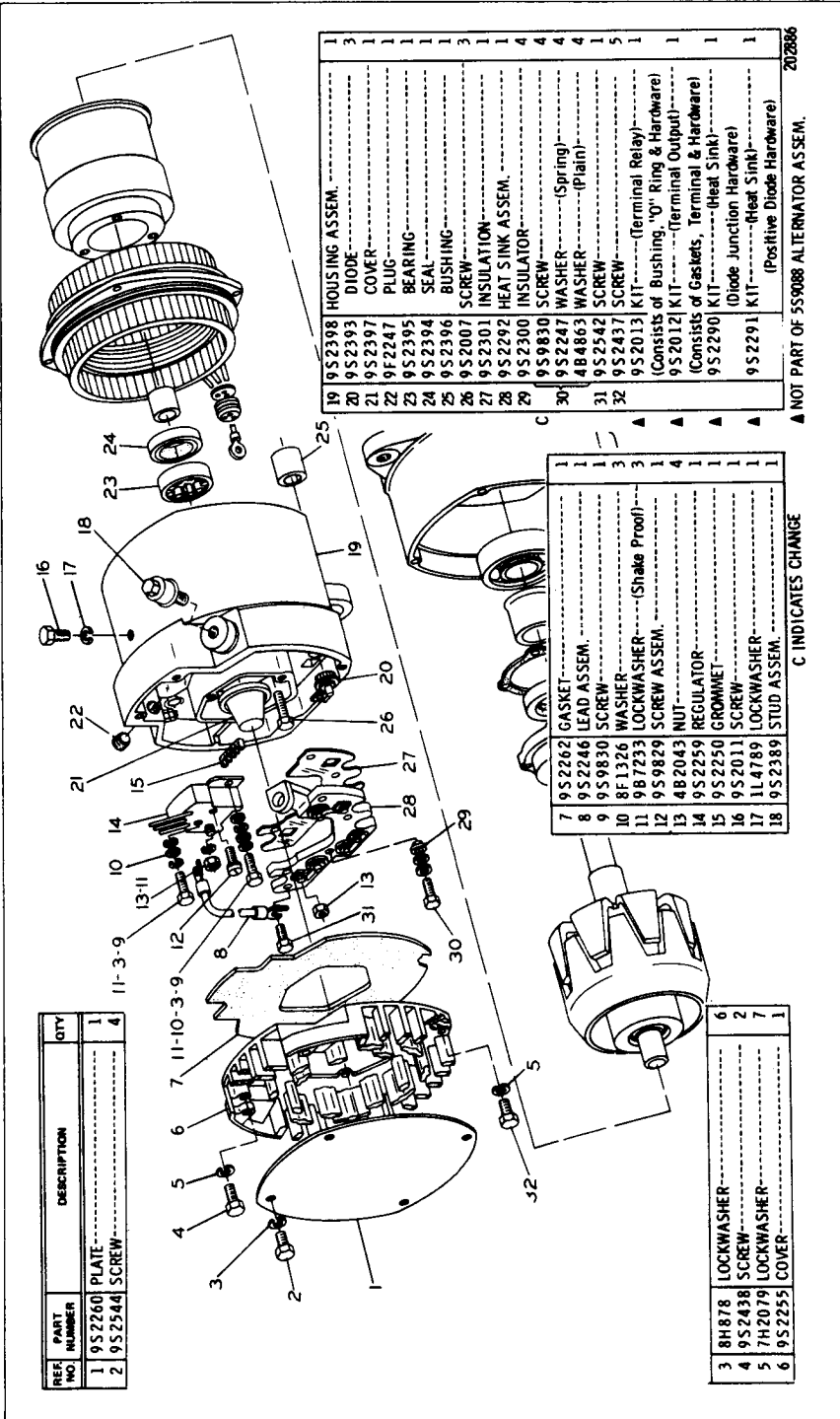

REF. NO.	PART NUMBER	DESCRIPTION	QTY
1	952260	PLATE	1
2	952544	SCREW	4

19	952398	HOUSING ASSEM.	1
20	952393	DIODE	3
21	952397	COVER	1
22	9F2247	PLUG	1
23	952395	BEARING	1
24	952394	SEAL	1
25	952396	BUSHING	1
26	952007	SCREW	3
27	952301	INSULATION	1
28	952292	HEAT SINK ASSEM.	1
29	952300	INSULATOR	4
30	959630	SCREW	4
31	952247	WASHER	4
32	4B4863	WASHER	4
33	952542	SCREW	4
34	952437	SCREW	5
35	952013	KIT	1
36	952012	KIT	1
37	952290	KIT	1
38	952291	KIT	1

7	952262	GASKET	1
8	952246	LEAD ASSEM.	1
9	959830	SCREW	1
10	8F1326	WASHER	3
11	9B7235	LOCKWASHER	3
12	959829	SCREW ASSEM.	3
13	4B2043	NUT	4
14	952259	REGULATOR	1
15	952250	GROMMET	1
16	952011	SCREW	1
17	1L4789	LOCKWASHER	1
18	952389	STUD ASSEM.	1

3	8H878	LOCKWASHER	6
4	952438	SCREW	2
5	7H2079	LOCKWASHER	7
6	952255	COVER	1

C INDICATES CHANGE

202886

▲ NOT PART OF 5S9088 ALTERNATOR ASSEM.

5S9088 ALTERNATOR ASSEMBLY—Part 1  
Part of 956693 Alternator Group listed on Page 40  
AN ATTACHMENT

5S9088 ALTERNATOR ASSEMBLY—Part 2  
Part of 9S6693 Alternator Group listed on Page 40  
AN ATTACHMENT

REF. NO.	PART NUMBER	DESCRIPTION	QTY
1	9S2242	RACE	1
2	9S2248	FIELD COIL AND SUPPORT ASSEM.	1
3	9S2004	STATOR ASSEM.	1
4	9S2006	INSULATOR	1
5	9S2005	GROMMET	1
6	9S2014	CLIP	3
7	9S2302	ROTOR ASSEM.	1
8	9S2390	RETAINER ASSEM.	1
9	9S2391	SEAL	1
10	9S2256	GASKET	1

11	9S2261	COLLAR	1
12	2F5721	BEARING	1
13	2P5616	FRAME	1
14	3B4502	LOCKWASHER	4
15	9S2009	BOLT	4
16	9S2391	SEAL	1
17	9S2254	COLLAR	1
18	9S2252	SLINGER	1

19	9S2008	SCREW	4
20	9S2258	FAN AND BAFFLE ASSEM.	1
21	7F7621	WASHER	1
22	2K4821	LOCKNUT	1

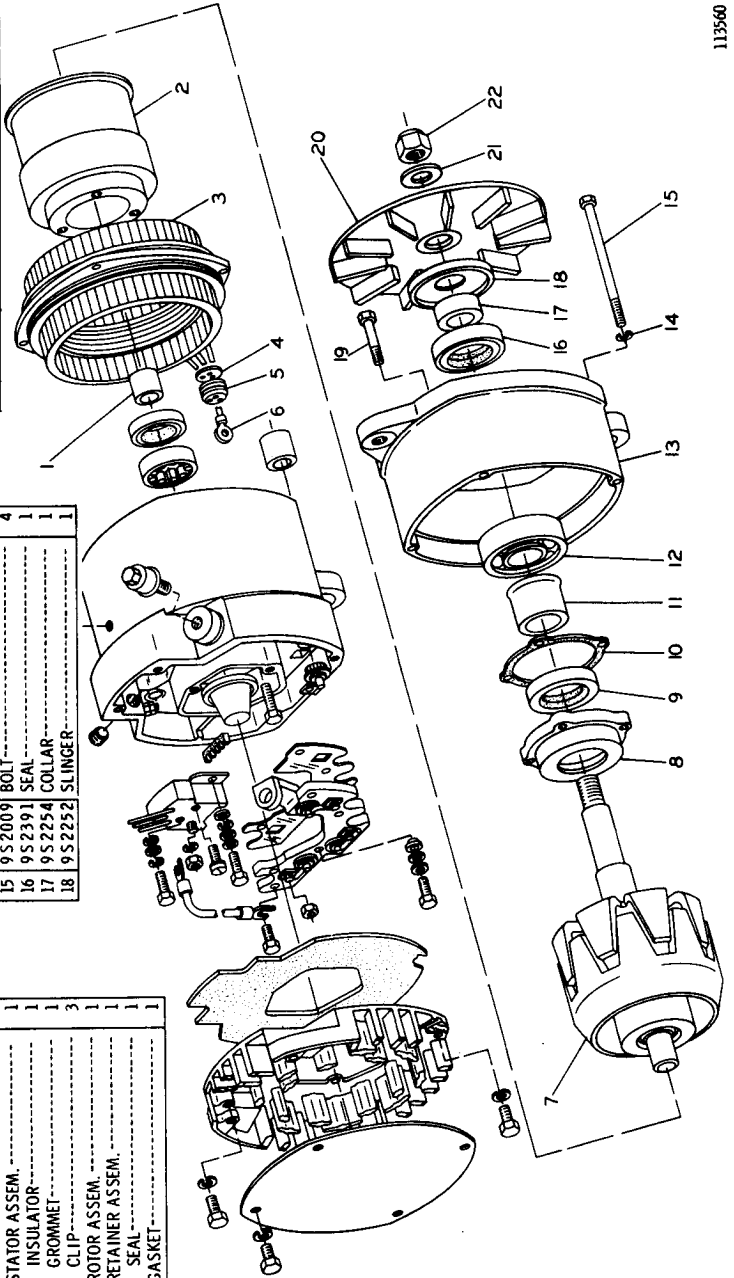

CONSISTS OF:

PAGE

- 1 9S6693 ALTERNATOR GROUP
  - CONSISTING OF:
    - 1 5S9088 ALTERNATOR ASSEMBLY..... 38
    - 1 5M6214 PIPE PLUG--CYLINDER BLOCK OIL PRESSURE PULLEY--ALTERNATOR DRIVE
    - 1 9S6129 WIRE ASSEMBLY--ALTERNATOR TO ENGINE
      - CONSISTING OF:
        - 1 9F9353 TERMINAL
        - 1 9F5320 TERMINAL
        - 2 8B653 INSULATOR
- 1 8M7892 AMMETER
- 1 9S173 CIRCUIT BREAKER

9S6591 ALTERNATOR ARRANGEMENT—24 Volt, 50 Ampere—Factory Installation AN ATTACHMENT

REF. NO.	PART NUMBER	DESCRIPTION	QTY
1	4M1816	TERMINAL ASSEM.-----	1
	4M1834	PLATE-----	1
2	7F4907	STRIP-----	1
3	3H3681	NUT-----	2
4	3B4508	LOCKWASHER-----	4
5	3H3680	NUT-----	2
6	7F3494	WASHER-----	2
7	4M1836	INSULATOR-----	2
8	4M1837	BUSHING-----	2
9	7F4906	STUD----- (R. H.)-----	1
	4M1835	STUD----- (L. H.)-----	1
10	4M2800	TERMINAL-----	1

11	9S4490	GASKET-----	1
12	4M5274	SCREW-----	1
13	9S4489	SCREW ASSEM.-----	4
14	4M3217	SCREW-----	2
15	4M1814	CONTACT ASSEM.-----	1
16	3P72	CASE ASSEM.-----	1
17	1F73	CLIP-----	2
18	4M1815	SPRING-----	1

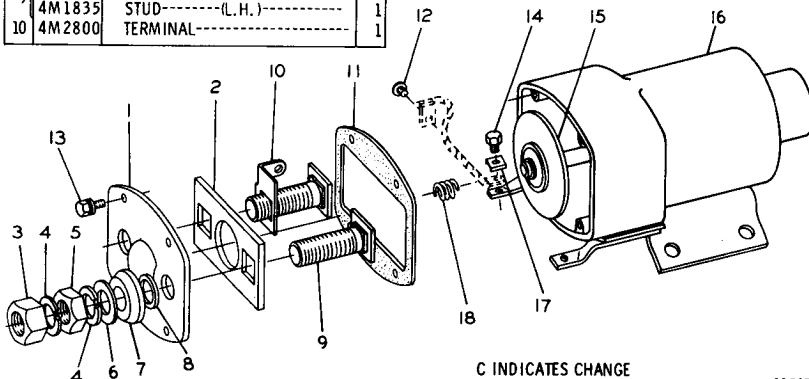

C INDICATES CHANGE

115475

1P9181 SOLENOID SWITCH ASSEMBLY  
Part of 2P3926 Starting Motor Group shown on Page 35  
AN ATTACHMENT

1P7210 LIGHTING GROUP—24 Volt, 4 Lamp  
 1P7191, 4S8000 Harness and 1M1882 Lamp parts are shown on Pages 43 and 44  
 AN ATTACHMENT

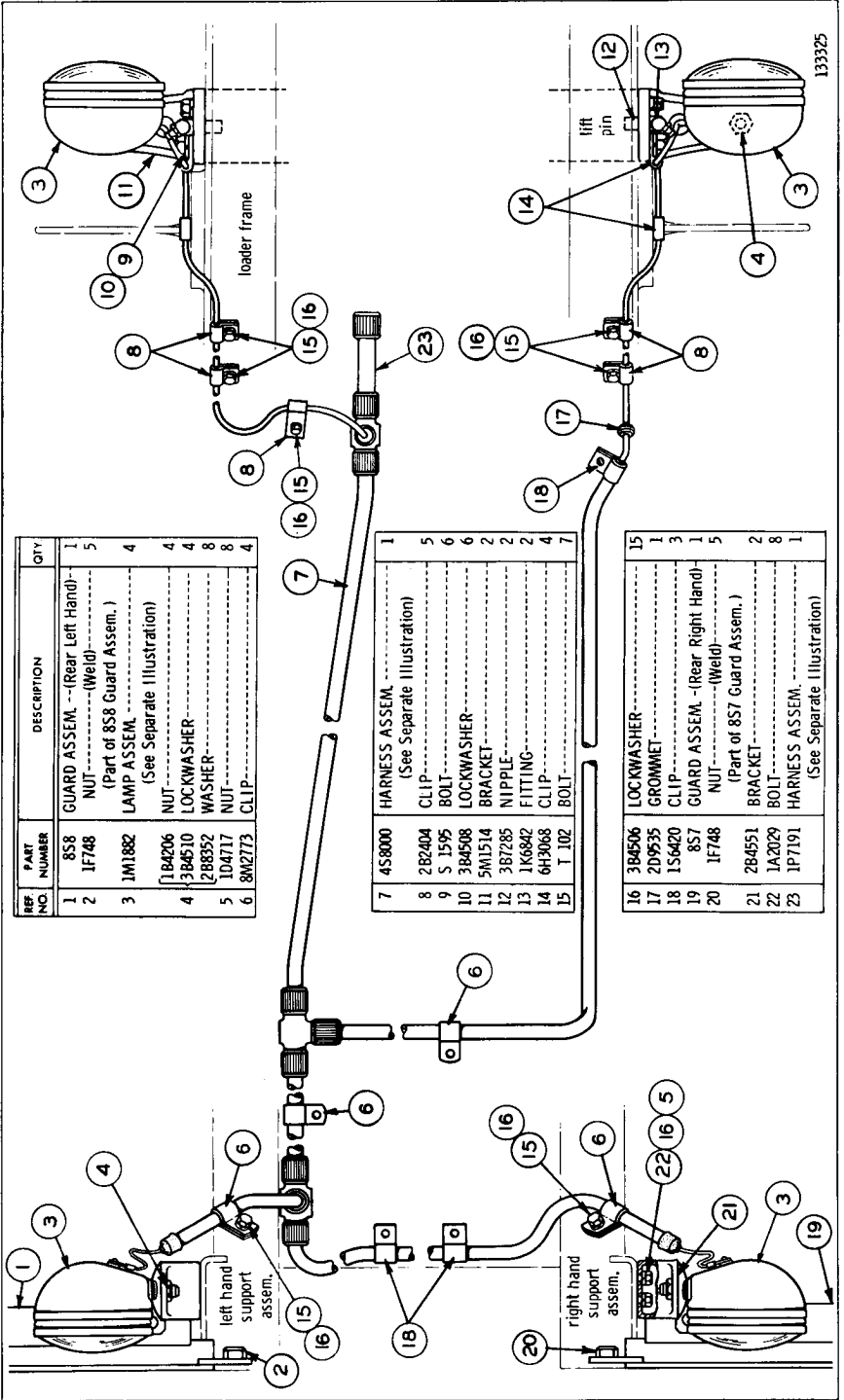

REF. NO.	PART NUMBER	DESCRIPTION	QTY.
1	8S8	GUARD ASSEM. --(Rear Left Hand)--	1
2	1F748	NUT-----(Weld)-----	5
3	1M1882	LAMP ASSEM. (Part of 8S8 Guard Assem.)	4
4	1B4206	NUT (See Separate Illustration)	4
4	3B4510	LOCKWASHER	4
5	2B8952	WASHER	8
5	1D4717	NUT	8
6	8M2773	CLIP	4

7	4S8000	HARNES ASSEM. (See Separate Illustration)	1
8	2B2404	CLIP	5
9	S 1595	BOLT	6
10	3B4508	LOCKWASHER	6
11	5M1514	BRACKET	2
12	3B7285	NIPPLE	2
13	1K6842	FITTING	2
14	6H3068	CLIP	4
15	T 102	BOLT	7

16	3B4506	LOCKWASHER	15
17	2D9535	GROMMET	1
18	1S6420	CLIP	3
19	8S7	GUARD ASSEM. --(Rear Right Hand)--	1
20	1F748	NUT----- (Weld)-----	5
21	2B4551	BRACKET (Part of 8S7 Guard Assem.)	2
22	1A2029	BOLT	8
23	1P7191	HARNES ASSEM. (See Separate Illustration)	1

133325

CATERPILLAR 977L TRAXCAVATOR

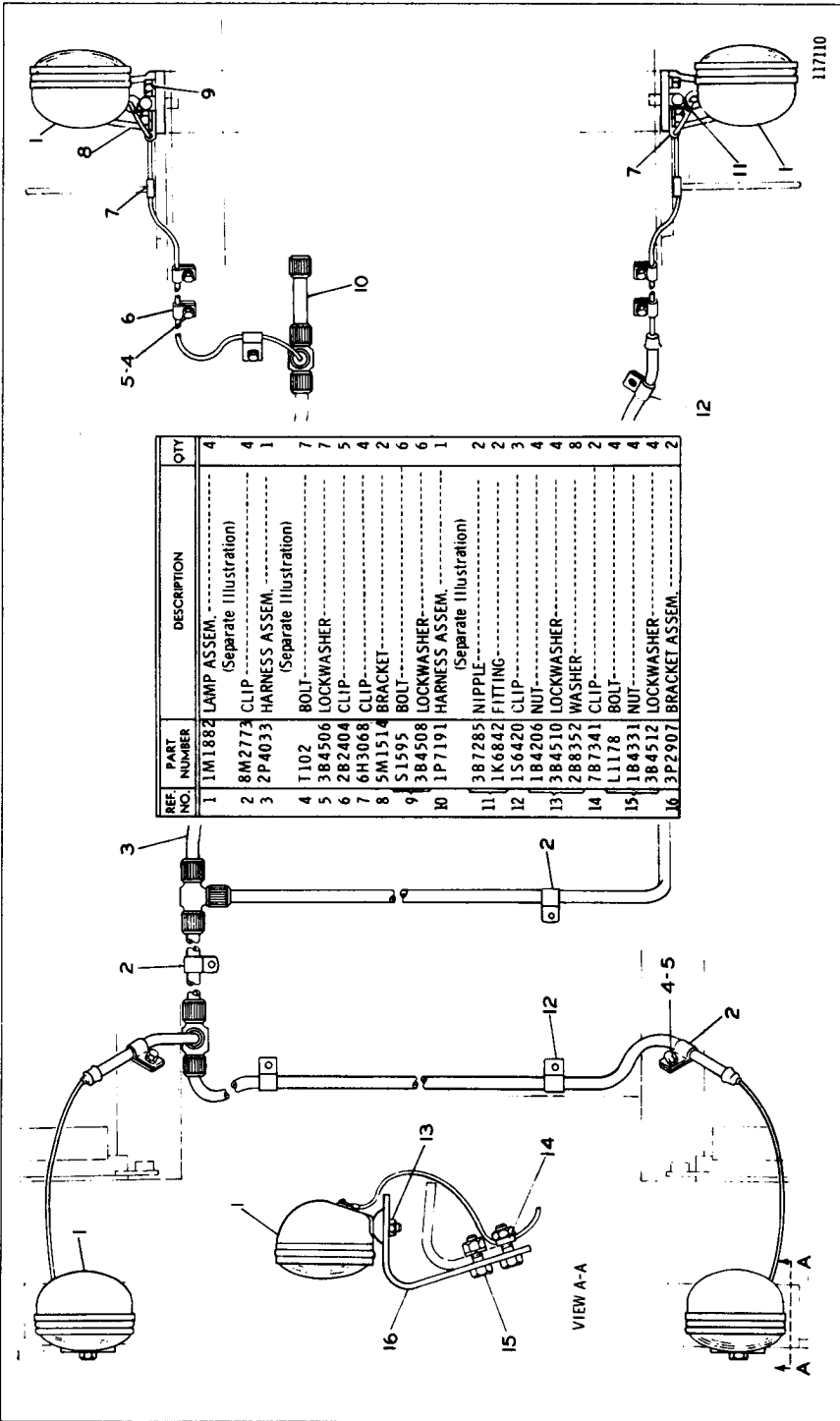

REF. NO.	PART NUMBER	DESCRIPTION	QTY
1	1M1882	LAMP ASSEM. (Separate Illustration)	4
2	8M2773	CLIP	4
3	2P4033	HARNES ASSEM. (Separate Illustration)	1
4	T102	BOLT	7
5	3B4506	LOCKWASHER	7
6	2B2404	CLIP	5
7	6H3068	CLIP	4
8	5M1514	BRACKET	2
9	51595	BOLT	6
10	1P7191	HARNES ASSEM. (Separate Illustration)	1
11	3B7285	NIPPLE	2
12	1K6642	FITTING	2
13	156420	CLIP	3
14	184206	NUT	4
15	3B4510	LOCKWASHER	4
16	2B8352	WASHER	8
1	7B7341	CLIP	2
1	L1178	BOLT	4
1	184331	NUT	4
1	3B4512	LOCKWASHER	4
1	13P2907	BRACKET ASSEM.	2

3P4669 LIGHTING GROUP—24 Volt, 4 Lamp  
 FOR USE WITH ROLL-OVER PROTECTIVE STRUCTURE  
 1M1882 Lamp & 2P4033 Harness parts are shown on Page 44  
 AN ATTACHMENT

117110

12

VIEW A-A

▲ ORDER BY THE FOOT  
● TWO 9M9661 TEE ARE REQUIRED TO MAKE A COMPLETE TEE

REF. NO.	PART NUMBER	DESCRIPTION	QTY
1	9M9661	TEE-----	2
2	1S2320	NUT-----	1
3	1S945	BOOT-----	1
4	8S5783	LINER-----	2
5	8S5782	RING-----	2

REF. NO.	PART NUMBER	DESCRIPTION	QTY
6	4S8751	CONDUIT-----12'	
7	9S5324	NUT ASSEM.-----	2
8	2S1043	BUTT-----	1
9	3S8183	CONNECTOR-----	3
10	2S5016	TERMINAL-----	1
11	2S5015	TERMINAL-----	2

133326

1P7191 HARNESS ASSEMBLY  
Part of 1P7210 & 3P4669 Lighting Groups shown on Pages 41 & 42  
AN ATTACHMENT

● Two 9M9661 are required to make a complete Tee

▲ ORDER BY THE FOOT

REF. NO.	PART NUMBER	DESCRIPTION	QTY
1	3S8180	CONNECTOR-----	2
2	2S5016	TERMINAL-----	1
3	4S8767	TUBE----- (25" O. D.)-----	93'
4	2L8075	TERMINAL-----	4
5	2S5015	TERMINAL-----	1
6	4S8751	CONDUIT--(use as required)--15 feet	
7	9M9662	NUT-----	7

REF. NO.	PART NUMBER	DESCRIPTION	QTY
8	1S2294	BOOT-----	3
9	1S6870	LINER-----	3
10	9M9661	TEE-----	4
11	8S5782	RING-----	7
12	2S1043	BUTT-----	1
13	8S5783	LINER-----	7

133327

4S8000 HARNESS ASSEMBLY  
Part of 1P7210 Lighting Group shown on Page 41  
AN ATTACHMENT

▲ ORDER BY THE FOOT

REF. NO.	PART NUMBER	DESCRIPTION	QTY.
1	3S8180	CONNECTOR-----	2
2	2S5016	TERMINAL-----	1
3	4S8767	TUBE----- (.25" O. D.)-----93"	1
4	2L8075	TERMINAL-----	4
5	2S5015	TERMINAL-----	1
6	4S8751	CONDUIT-(use as required)-15 feet	1
7	9S5324	NUT-----	7

REF. NO.	PART NUMBER	DESCRIPTION	QTY.
8	1S2294	BOOT-----	3
9	1S6870	LINER-----	3
10	9M9661	TEE-----	4
11	8S5782	RING-----	7
12	2S1043	BUTT-----	1
13	8S5783	LINER-----	7

134828

2P4033 HARNESS ASSEMBLY  
Part of 3P4669 Lighting Group shown on Page 42  
AN ATTACHMENT

C INDICATES CHANGE

REF. NO.	PART NUMBER	DESCRIPTION	QTY.
1	1M5898	SEALED UNIT-----	1
C 2	2P2541	BODY ASSEM.-----	1
3	2M5282	RING-----	1
4	2M5284	MOULDING ASSEM.-----	2
	5M6668	SCREW-----	2
	FE035430	FORM-----	1

(Instructions For Installing Lamp Assem. 1)

119409

1M1882 FLOOD LAMP ASSEMBLY  
Part of 1P7210 and 3P4669 Lighting Groups shown on Pages 41 and 42  
Only separate parts serviced  
AN ATTACHMENT

6K7376 WARNING AND WIRING GROUP—Factory Installation  
 Part of 6K5440 Hydraulic Arrangement listed on Page 150  
 AN ATTACHMENT

REF. NO.	PART NUMBER	DESCRIPTION	QTY
C 1	4 58760	TUBE..... 3 in.	1
C 2	4 K 6499	GROMMET.....	1

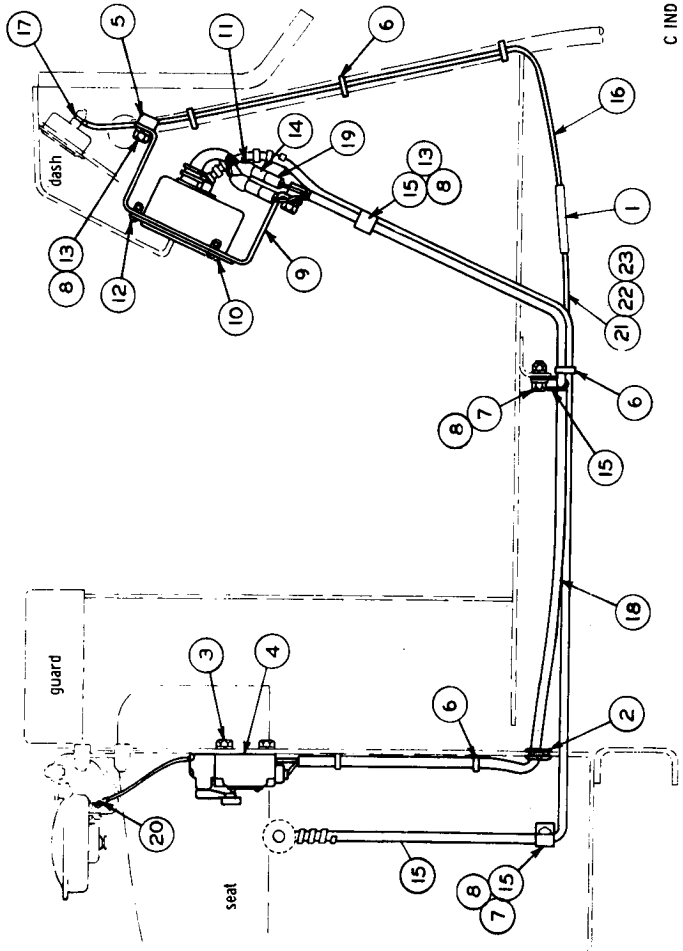

3	12 A 762	BOLT.....	4
4	3 B 4504	LOCKWASHER.....	4
4	1 B M 358	SWITCH ASSEM.....	1
5	5 88855	PLATE.....	4
C 6	3 52093	TIE.....	7
C 7	1 A 2029	BOLT.....	4
7	4 B 4278	WASHER.....	4
8	10 4717	NUT.....	4
8	3 B 4506	LOCKWASHER.....	9
9	6 K 7480	BRACKET.....	1
10	4 K 2940	THERMOMETER ASSEM.....	1
11	3 M 6018	TERMINAL.....	4
11	3 M 6017	SLEEVE.....	4
11	3 M 6015	SHELL.....	4
12	4 B 1221	SCREW.....	3
12	4 B 2043	NUT.....	3
13	3 B 4501	LOCKWASHER.....	3
C 13	1 1102	BOLT.....	2
14	4 K 2341	CONNECTOR.....	5
C 15	1 H 5166	CLIP.....	5
16	9 K 4178	WIRE ASSEM.....	1
16	1 H 6249	CLASP.....	1
17	2 L 8076	TERMINAL.....	1
18	6 K 7694	HARNES ASSEM.....	1
19	3 M 6018	TERMINAL.....	2
19	3 M 6017	SLEEVE.....	2
19	3 M 6015	SHELL.....	2
C 20	2 L 8075	TERMINAL.....	2
21	9 K 4179	WIRE ASSEM.....	1
22	2 L 8075	TERMINAL.....	1
23	1 H 6249	CLASP.....	1

C INDICATES CHANGE ▲ ORDER BY THE FOOT

117021



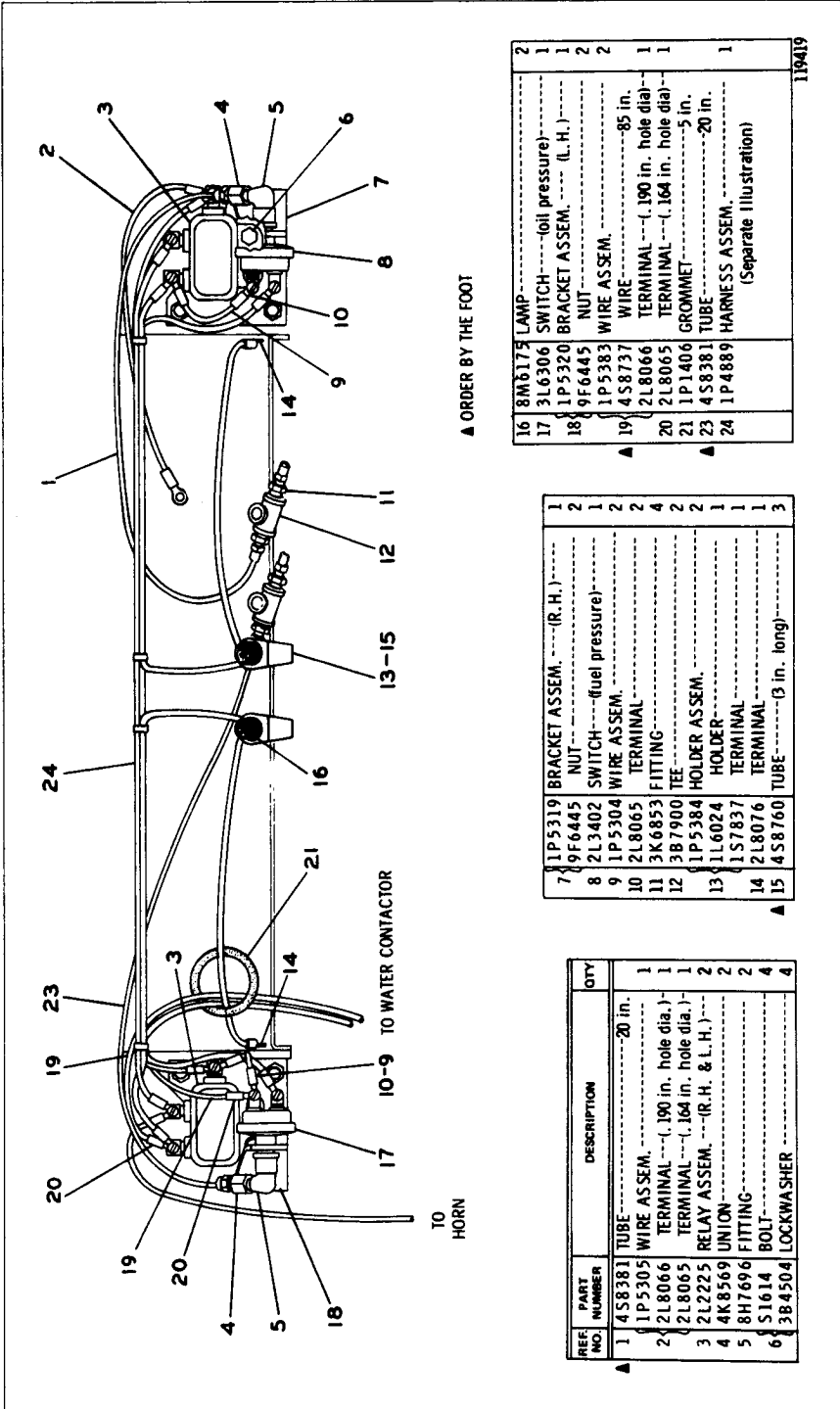

16	8M6175	LAMP	2
17	3L6306	SWITCH (oil pressure)	1
18	1P5320	BRACKET ASSEM. (L.H.)	1
18	9F6445	NUT	2
19	1P5383	WIRE ASSEM.	2
19	4S8737	WIRE	85 in.
20	2L8066	TERMINAL (-, 190 in. hole dia.)	1
21	2L8065	TERMINAL (-, 164 in. hole dia.)	1
21	1P1406	GROMMET	5 in.
23	4S8381	TUBE	20 in.
24	1P4889	HARNES ASSEM. (Separate Illustration)	1

7	1P5319	BRACKET ASSEM. (R.H.)	1
8	9F6445	NUT	2
8	2L3402	SWITCH (fuel pressure)	1
9	1P5304	WIRE ASSEM.	2
10	2L8065	TERMINAL	2
11	3K6853	FITTING	4
12	3B7900	TEE	2
13	1P5384	HOLDER ASSEM.	2
13	1L6024	HOLDER	1
14	1S7837	TERMINAL	1
14	2L8076	TERMINAL	1
15	4S8760	TUBE (3 in. long)	3

REF. NO.	PART NUMBER	DESCRIPTION	QTY
1	4S8381	TUBE 20 in.	1
2	1P5305	WIRE ASSEM.	1
2	2L8066	TERMINAL (-, 190 in. hole dia.)	1
3	2L8065	TERMINAL (-, 164 in. hole dia.)	1
4	2L2225	RELAY ASSEM. (R.H. & L.H.)	2
5	4R8569	UNION	2
5	8H7696	FITTING	2
6	S1614	BOLT	4
6	3B4504	LOCKWASHER	4

1P5381 ENGINE FUNCTION WARNING GROUP—Part 1  
 Part of 1P9409 Steel Mill Traxcavator Arrangement listed on Page 104  
 1P4889 Harness parts are shown on Page 48: AN ATTACHMENT

1P5381 ENGINE FUNCTION WARNING GROUP—Part 2  
Part of 1P9409 Steel Mill Traxcavator Arrangement listed on Page 104  
AN ATTACHMENT

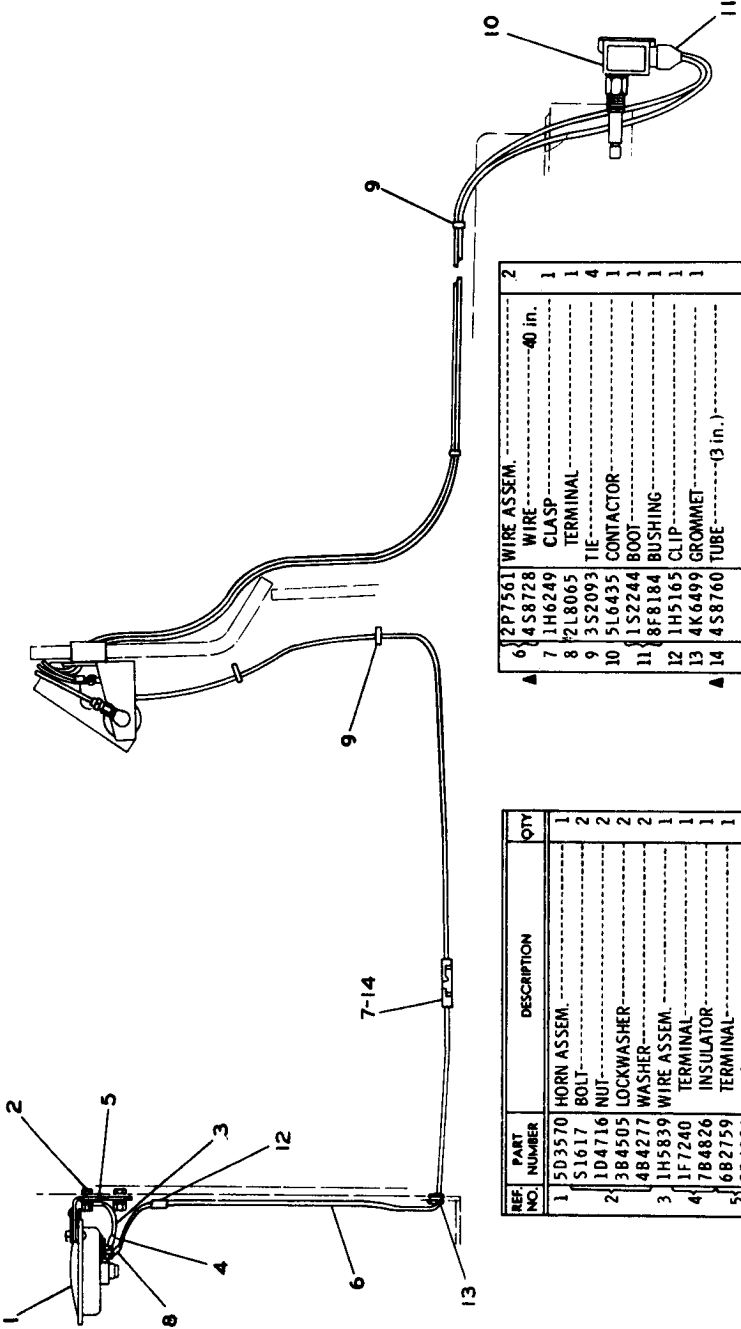

REF. NO.	PART NUMBER	DESCRIPTION	QTY
1	5D3570	HORN ASSEM.	1
	S1617	BOLT	2
2	1D4716	NUT	2
	3B4505	LOCKWASHER	2
	4B4277	WASHER	2
3	1H5839	WIRE ASSEM.	1
4	1F7240	TERMINAL	1
	7B4826	INSULATOR	1
5	6B2759	TERMINAL	1
	7B4826	INSULATOR	1

  

REF. NO.	PART NUMBER	DESCRIPTION	QTY
6	2P7561	WIRE ASSEM.	2
	458728	WIRE	1
7	1H6249	CLASP	1
8	2L8065	TERMINAL	1
	352093	TIE	4
9	5L6435	CONTACTOR	1
10	1S2244	BOOT	1
11	8F8184	BUSHING	1
12	1H5165	CLIP	1
13	4K6499	GROMMET	1
14	458760	TUBE	1

▲ ORDER BY THE FOOT

119420

CATERPILLAR 977L TRAXCAVATOR

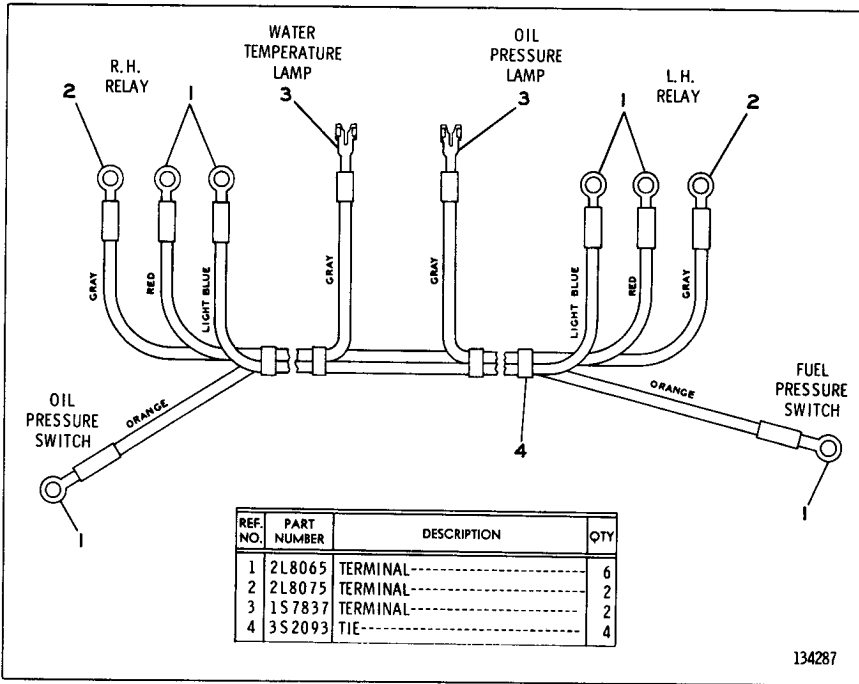

**1P4889 WIRING HARNESS ASSEMBLY**  
 Part of 1P5381 Engine Function Warning Group shown on Page 46  
 AN ATTACHMENT

3P4421 BACKUP WARNING GROUP—Factory Installation  
 Serial No. 11K5117—Up  
 FOR USE WITH ROLL-OVER PROTECTIVE STRUCTURE  
 6P3460 Harness parts are shown on Page 50. AN ATTACHMENT

14	5509	BOLT	1
15	384506	LOCKWASHER	1
16	1A2029	BOLT	2
17	484278	WASHER	2
	3P8990	SWITCH ASSEM.	1
	5B2183	NUT	2
	2H4130	WASHER	2

REF. NO.	PART NUMBER	DESCRIPTION	QTY.
1	6P2243	SPEAKER ASSEM.	1
2	3P4285	GUARD ASSEM.	3
3	51570	BOLT	3
3	384504	LOCKWASHER	3
4	51587	BOLT	4
4	1D4719	NUT	4
4	384508	LOCKWASHER	4
4	484280	WASHER	4
5	6D3460	HARNES ASSEM. (Separate Illustration)	1
6	6K806	STRAP	10
7	3P5055	WIRE ASSEM. (Includes)	1
7	5P384	TUBE—4.57 dmi(18.00 in.)	1
7	5P497	WIRE—4.83 dmi(19.00 in.)	1
8	2L8079	TERMINAL	1
9	2S5012	CAP.	1
9	2S5014	CONTACT	1

10	3P8989	FUSE—(2 amp)	1
11	3P4414	BRACKET	1
11	8D5578	MAGNET ASSEM. (Includes)	1
12	2L6726	RING	1
12	6D9677	FILTER	1
13	3P4413	BRACKET	1

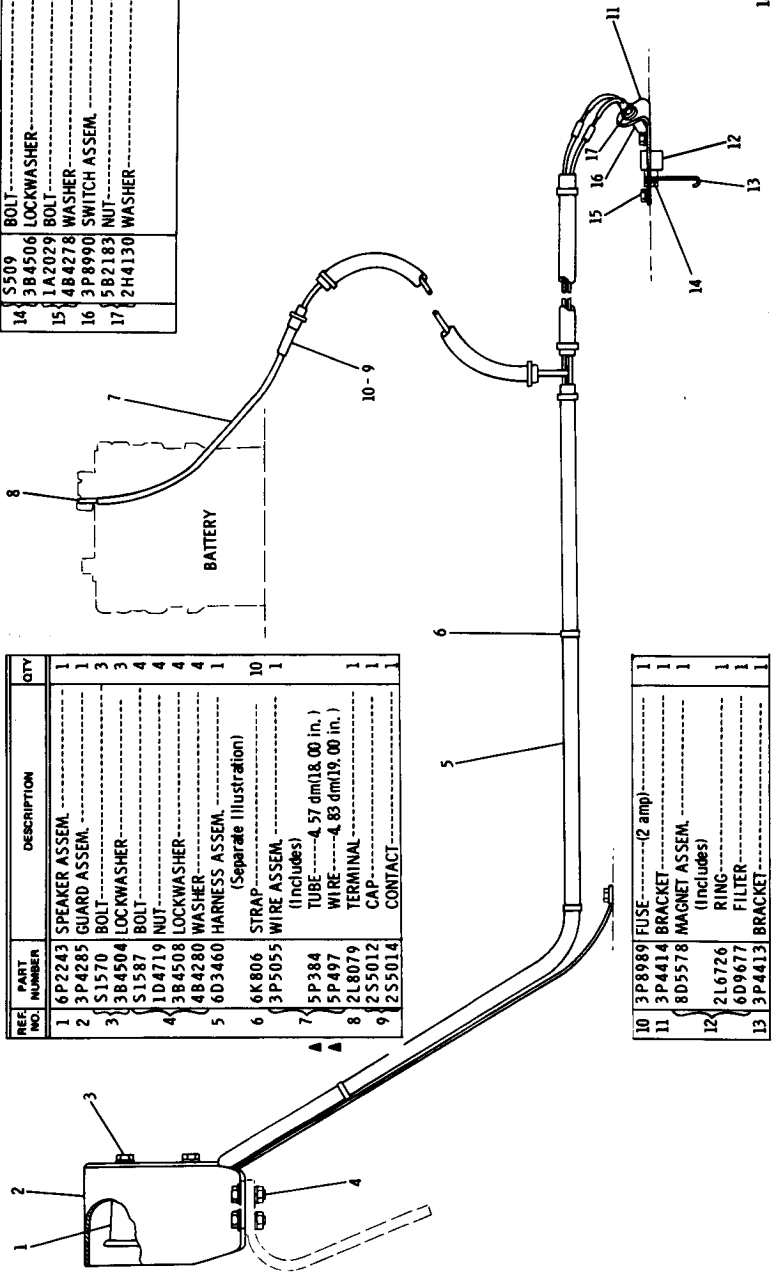

▲ ORDER BY THE DECIMETRE

148104

REF. NO.	PART NUMBER	DESCRIPTION	QTY
1	2S5014	CONTACT	1
2	2S5013	SPRING	1
3	2S5011	BODY	1
4	3S2093	TIE	6
5	5P384	TUBE-----4.57 dm(18 in.)	
6	5P384	TUBE-----4.57 dm(18 in.)	
7	5P384	TUBE-----4.57 dm(18 in.)	
8	2L8079	TERMINAL	1
THE FOLLOWING WIRES ARE AVAILABLE:			
▲ 9	5P497	WIRE-----14 gauge)	

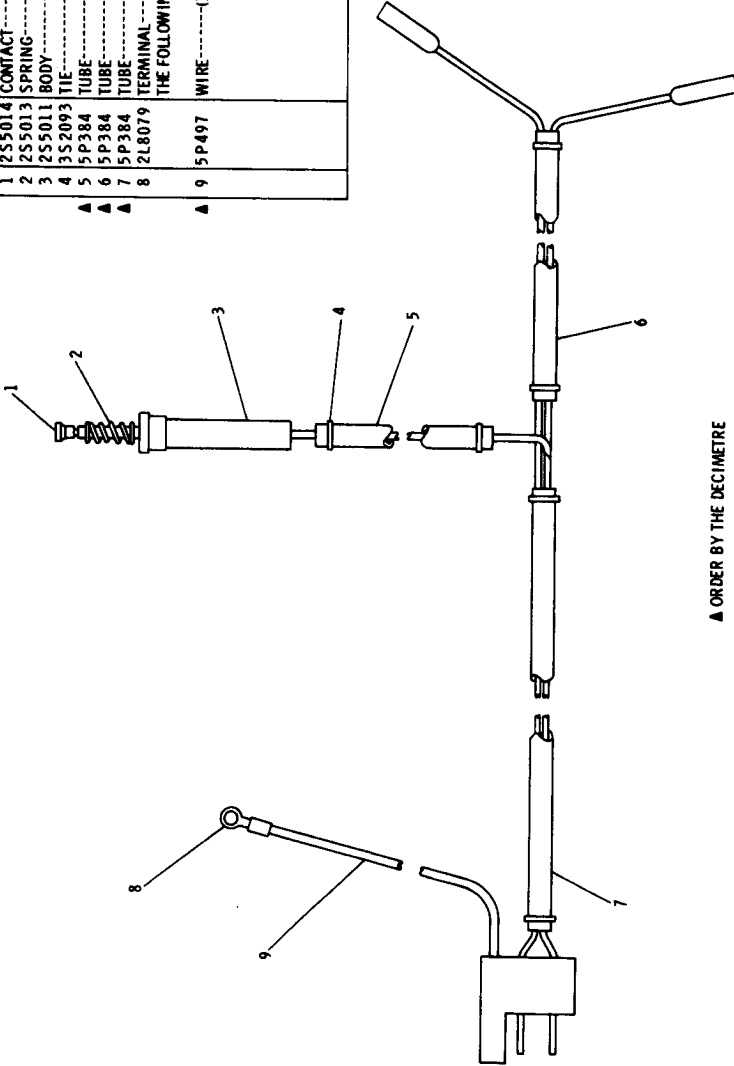

▲ ORDER BY THE DECIMETRE

148219

6P3460 HARNES ASSEMBLY  
Serial No. 11K5117—Up

Part of 3P4421 Backup Warning Group shown on Page 49

POWER TRAIN ARRANGEMENT

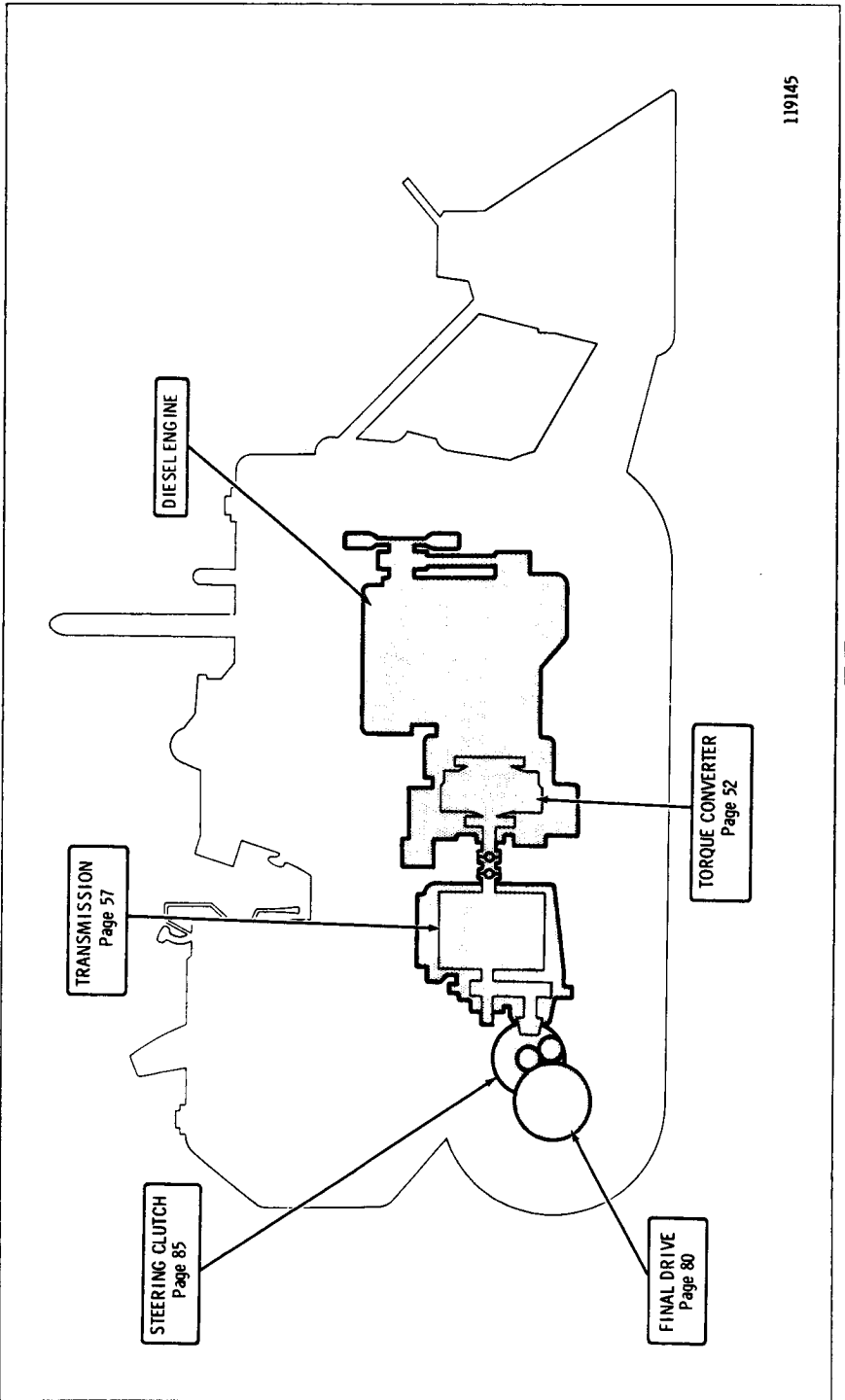

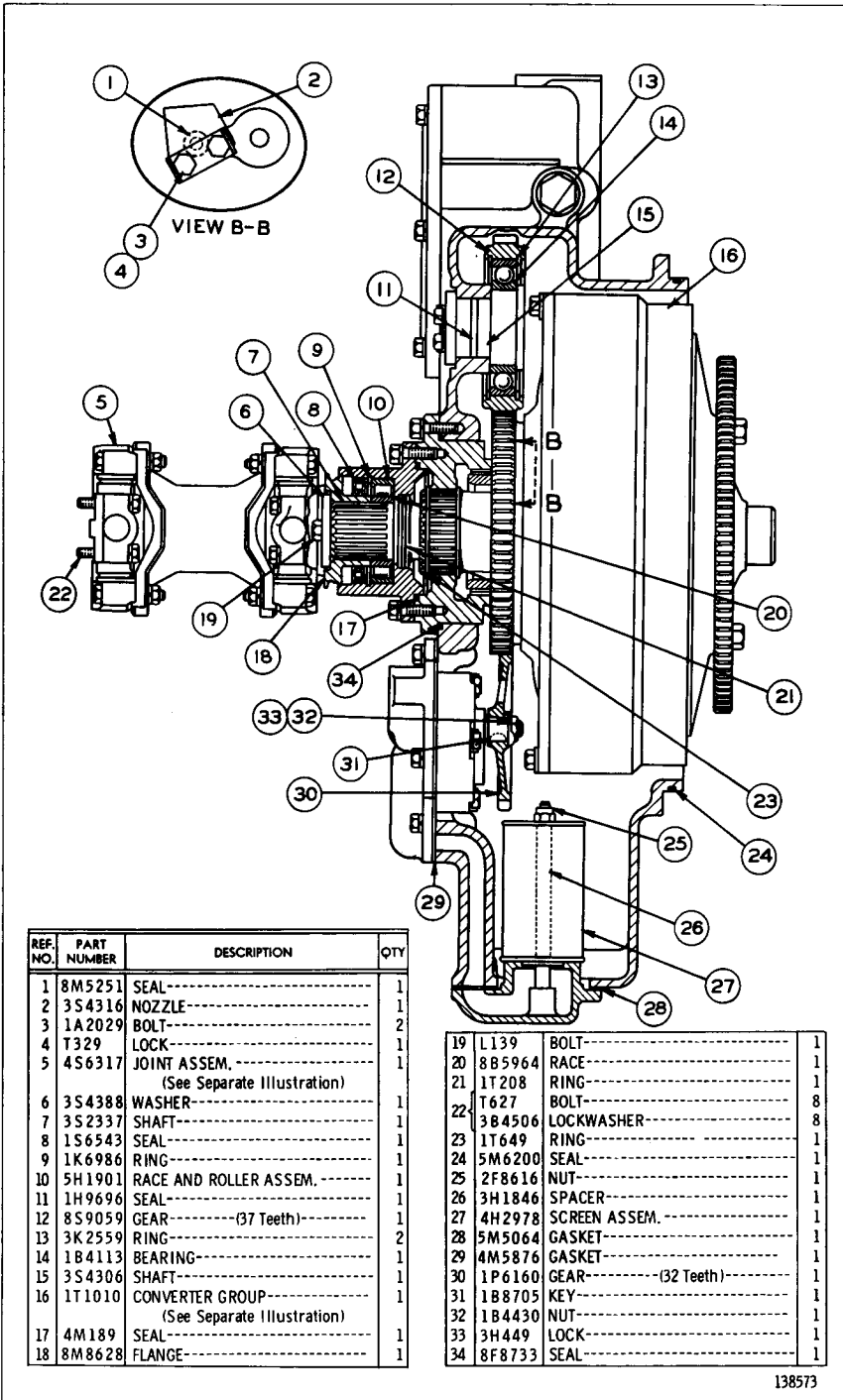

138573

TORQUE CONVERTER (3S2700 N/S)  
 AS VIEWED FROM R.H. SIDE OF MACHINE  
 Serial No. 11K5051 to 11K5875 and 11K6137—Up. 1T1010 Torque Converter  
 and 4S6317 Joint parts are shown on Pages 54 and 56

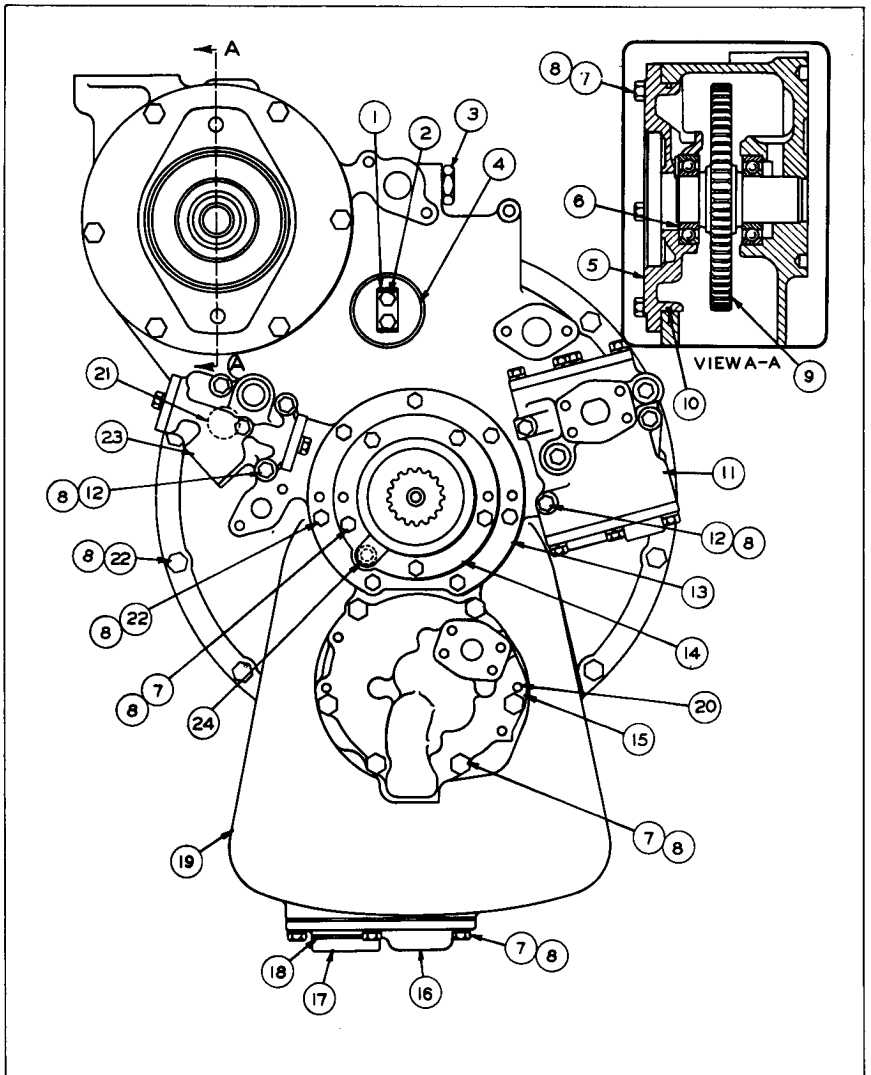

REF. NO.	PART NUMBER	DESCRIPTION	QTY
1	9M1367	LOCK-----	1
2	S1594	BOLT-----	2
3	4S8566	PLUG ASSEM.-----	1
3	3D2824	"O" RING-----	1
4	5M7339	WASHER-----	1
5	2P2104	ADAPTER-----	1
6	4S5874	BEARING-----	2
7	1A2029	BOLT-----	22
8	3B4506	LOCKWASHER-----	45
9	1P6161	GEAR----- (48 Teeth)	1
10	1J2176	SEAL-----	1
11	9S5281	VALVE GROUP----- (See Separate Illustration)	1
12	S1619	BOLT-----	6

13	2P1059	CARRIER ASSEM.-----	1
	1T969	BEARING-----	1
14	3S4334	SUPPORT-----	1
15	5M7864	PUMP GROUP----- (See Separate Illustration)	1
16	5M5071	COVER-----	1
	7B533	STUD-----	1
17	8B6599	PLUG-----	1
18	L1124	GASKET-----	1
19	3S4281	COVER ASSEM.-----	1
20	5B5212	DOWEL-----	2
21	1A4672	PLUG-----	2
22	S1588	BOLT-----	17
23	3S2695	VALVE GROUP----- (See Separate Illustration)	1
24	8M5251	SEAL-----	1

C INDICATES CHANGE

138574

TORQUE CONVERTER (3S2700 N/S)  
 AS VIEWED FROM REAR OF MACHINE. Serial No. 11K5051 to 11K5875 and  
 11K6137—Up. 3S2695, 9S5281 Valve and 5M7864 Pump parts are  
 shown on Pages 55 and 56



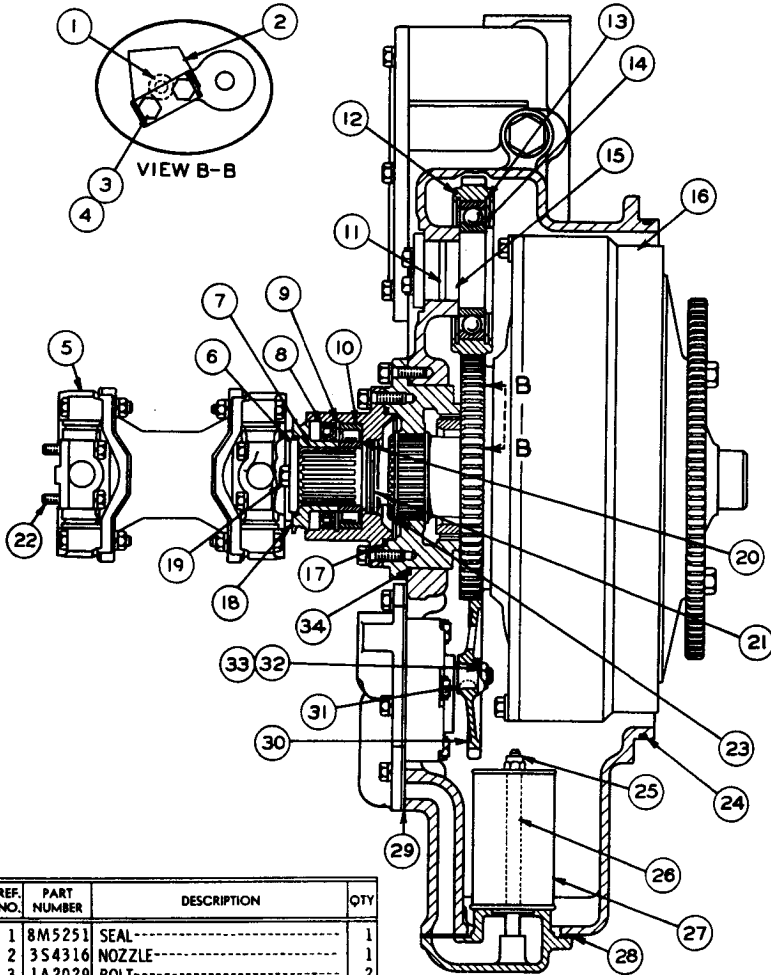

REF. NO.	PART NUMBER	DESCRIPTION	QTY
1	8M5251	SEAL-----	1
2	3S4316	NOZZLE-----	1
3	1A2029	BOLT-----	2
4	T329	LOCK-----	1
5	4S6317	JOINT ASSEM.----- (See Separate Illustration)	1
6	3S4388	WASHER-----	1
7	3S2337	SHAFT-----	1
8	1S6543	SEAL-----	1
9	1K6986	RING-----	1
10	5H1901	RACE AND ROLLER ASSEM.-----	1
11	1H9696	SEAL-----	1
12	8S9059	GEAR----- (37 Teeth)	1
13	3K2559	RING-----	2
14	1B4113	BEARING-----	1
15	3S4306	SHAFT-----	1
16	1T1010	CONVERTER GROUP----- (See Separate Illustration)	1
17	4M189	SEAL-----	1
18	8M8628	FLANGE-----	1

19	L139	BOLT-----	1
20	8B5964	RACE-----	1
21	1T208	RING-----	1
	T627	BOLT-----	8
22	3B4506	LOCKWASHER-----	8
23	1T649	RING-----	1
24	5M6200	SEAL-----	1
25	2F8616	NUT-----	1
26	3H1846	SPACER-----	1
27	4H2978	SCREEN ASSEM.-----	1
28	5M5064	GASKET-----	1
29	4M5876	GASKET-----	1
30	1P6160	GEAR----- (32 Teeth)	1
31	1B8705	KEY-----	1
32	1B4430	NUT-----	1
33	3H449	LOCK-----	1
34	8F8733	SEAL-----	1

138573

TORQUE CONVERTER (3S2700 N/S)  
 AS VIEWED FROM R.H. SIDE OF MACHINE. Serial No. 11K5876 to 11K6136  
 inclusive. 1T1010 Torque Converter and 4S6317 Joint parts are shown  
 on Pages 54 and 56

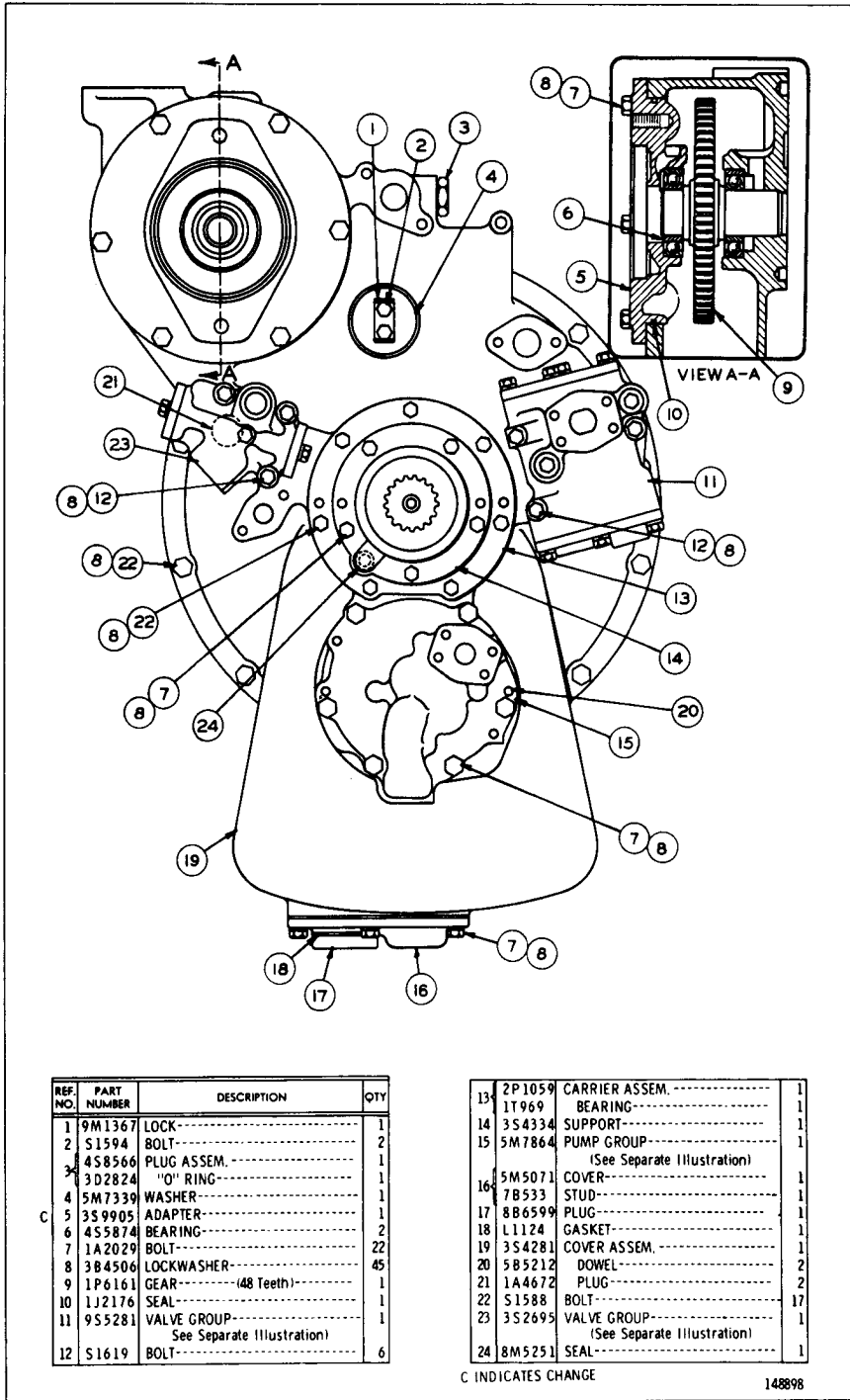

REF. NO.	PART NUMBER	DESCRIPTION	QTY
1	9M1367	LOCK	1
2	S1594	BOLT	2
3	4S8566	PLUG ASSEM.	1
4	3D2824	"O" RING	1
5	5M7339	WASHER	1
5	3S9905	ADAPTER	1
6	4S5874	BEARING	2
7	1A2029	BOLT	22
8	3B4506	LOCKWASHER	45
9	1P6161	GEAR (48 Teeth)	1
10	1J2176	SEAL	1
11	9S5281	VALVE GROUP (See Separate Illustration)	1
12	S1619	BOLT	6

13	2P1059	CARRIER ASSEM.	1
13	1T969	BEARING	1
14	3S4334	SUPPORT	1
15	5M7864	PUMP GROUP (See Separate Illustration)	1
16	5M5071	COVER	1
17	7B533	STUD	1
17	8B6599	PLUG	1
18	L1124	GASKET	1
19	3S4281	COVER ASSEM.	1
20	5B5212	DOWEL	2
21	1A4672	PLUG	2
22	S1588	BOLT	17
23	3S2695	VALVE GROUP (See Separate Illustration)	1
24	8M5251	SEAL	1

C INDICATES CHANGE

148898

TORQUE CONVERTER (3S2700 N/S)  
 AS VIEWED FROM REAR OF MACHINE. Serial No. 11K5876 to 11K6136  
 inclusive. 3S2695, 9S5281 Valve and 5M7864 Pump parts are shown on  
 Pages 55 and 56

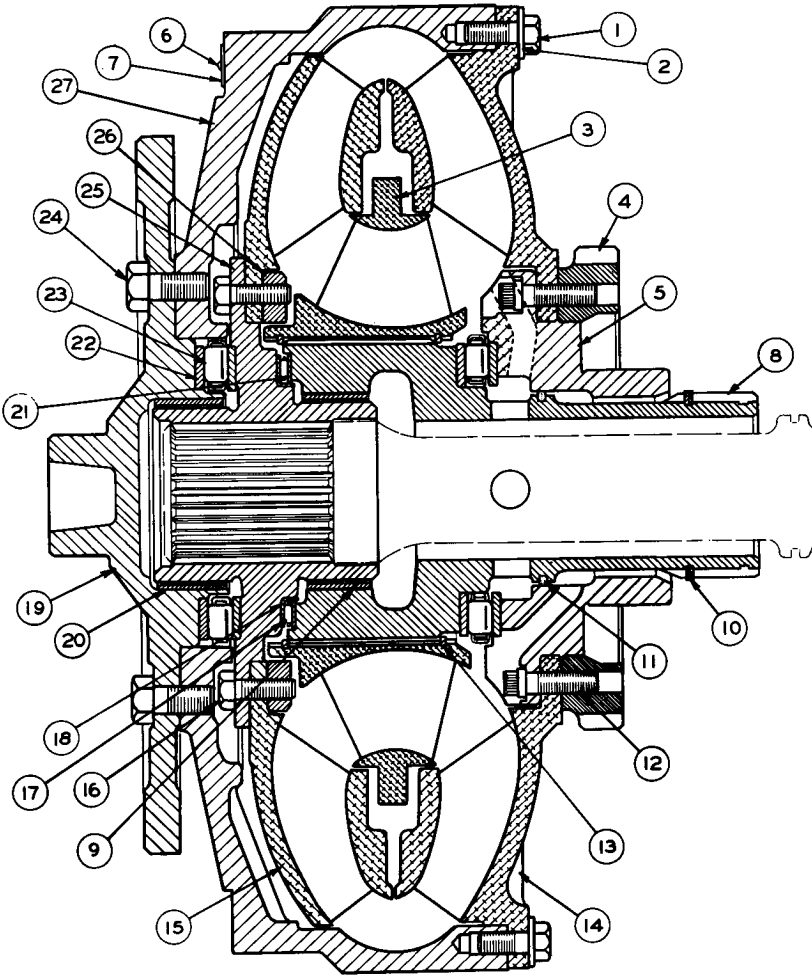

REF. NO.	PART NUMBER	DESCRIPTION	QTY
1	S1594	BOLT	36
2	1T689	WASHER	36
3	1T708	STATOR	1
4	1T989	GEAR	1
5	1T987	HUB	1
6	4B4158	SCREW	2
7	1T688	PLATE	1
8	1T711	CARRIER ASSEM.	1
9	1T766	BEARING	1
10	1T649	RING	1
11	1T648	SEAL	1
12	1T720	BOLT	12
13	1T651	RING	2
14	1T709	IMPELLER	1
15	1T662	TURBINE	1

16	6F7030	BOLT	20
17	1T706	BEARING	1
18	1T762	RACE	1
19	1T716	SPIDER ASSEM.	1
20	1T766	BEARING	1
21	1T763	RACE	1
22	1T686	RACE	4
23	1T655	BEARING	2
24	S1621	BOLT	12
25	1T714	HUB	1
26	1T665	RING	1
27	1T669	HOUSING	1

137234

1T1010 TORQUE CONVERTER GROUP  
Part of Torque Converter shown on Page 52

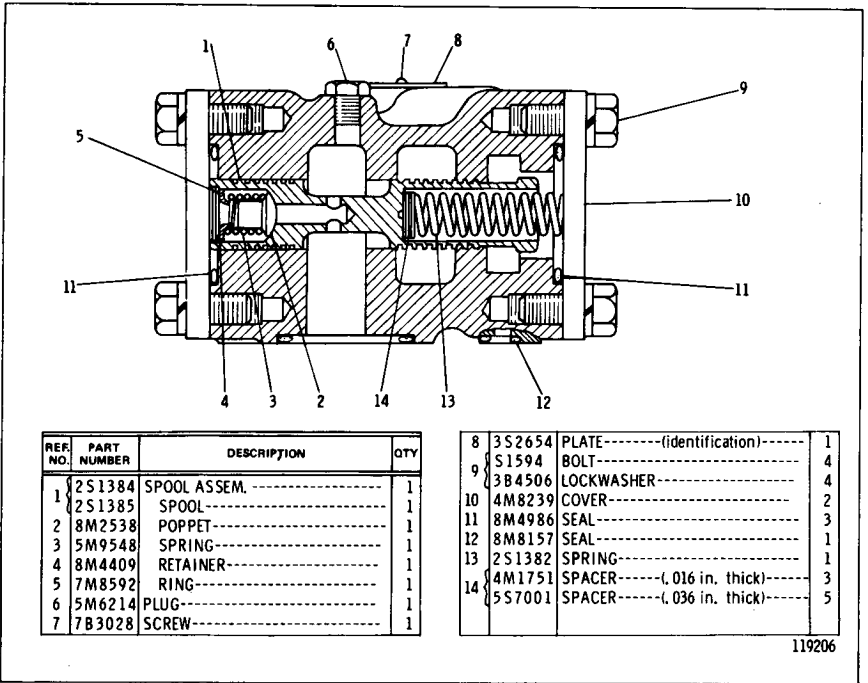

3S2695 RELIEF VALVE GROUP  
Part of Torque Converter shown on Page 53

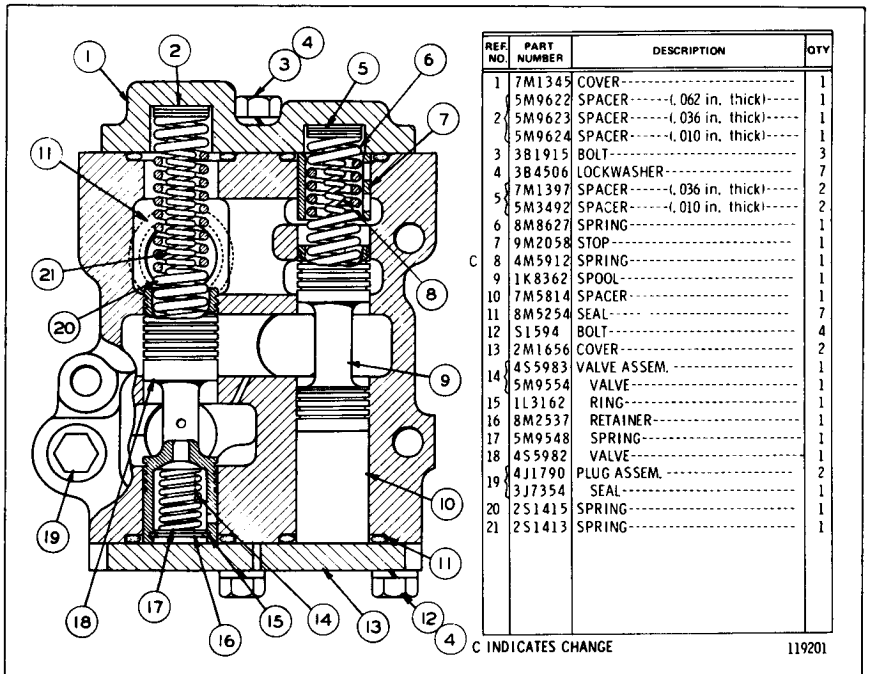

9S5281 RELIEF VALVE GROUP  
Part of Torque Converter shown on Page 53

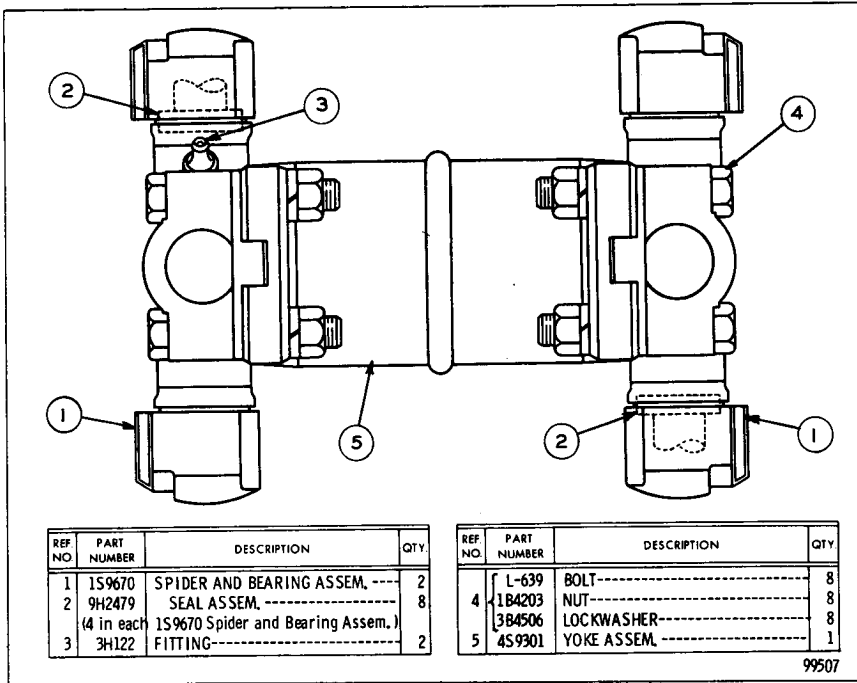

4S6317 UNIVERSAL JOINT ASSEMBLY  
Part of Torque Converter shown on Page 52

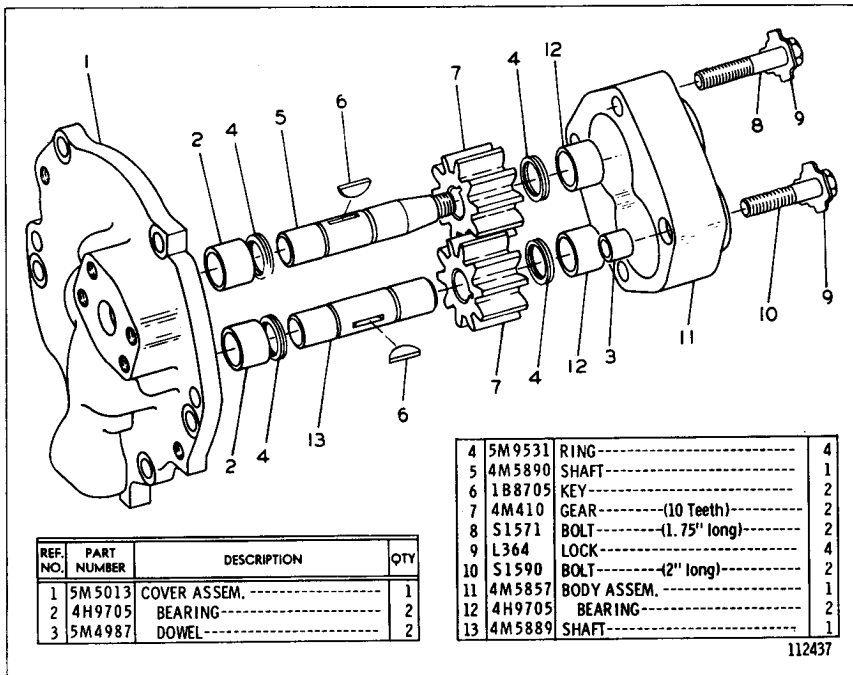

5M7864 SCAVENGE PUMP GROUP  
Part of Torque Converter shown on Page 53

3S2706 RANGE TRANSMISSION ARRANGEMENT  
 Transmission Hydraulic Control, Planetary Transmission, Transfer Gears  
 and 8M8551 Valve parts are shown on Pages 59 and 62 through 65

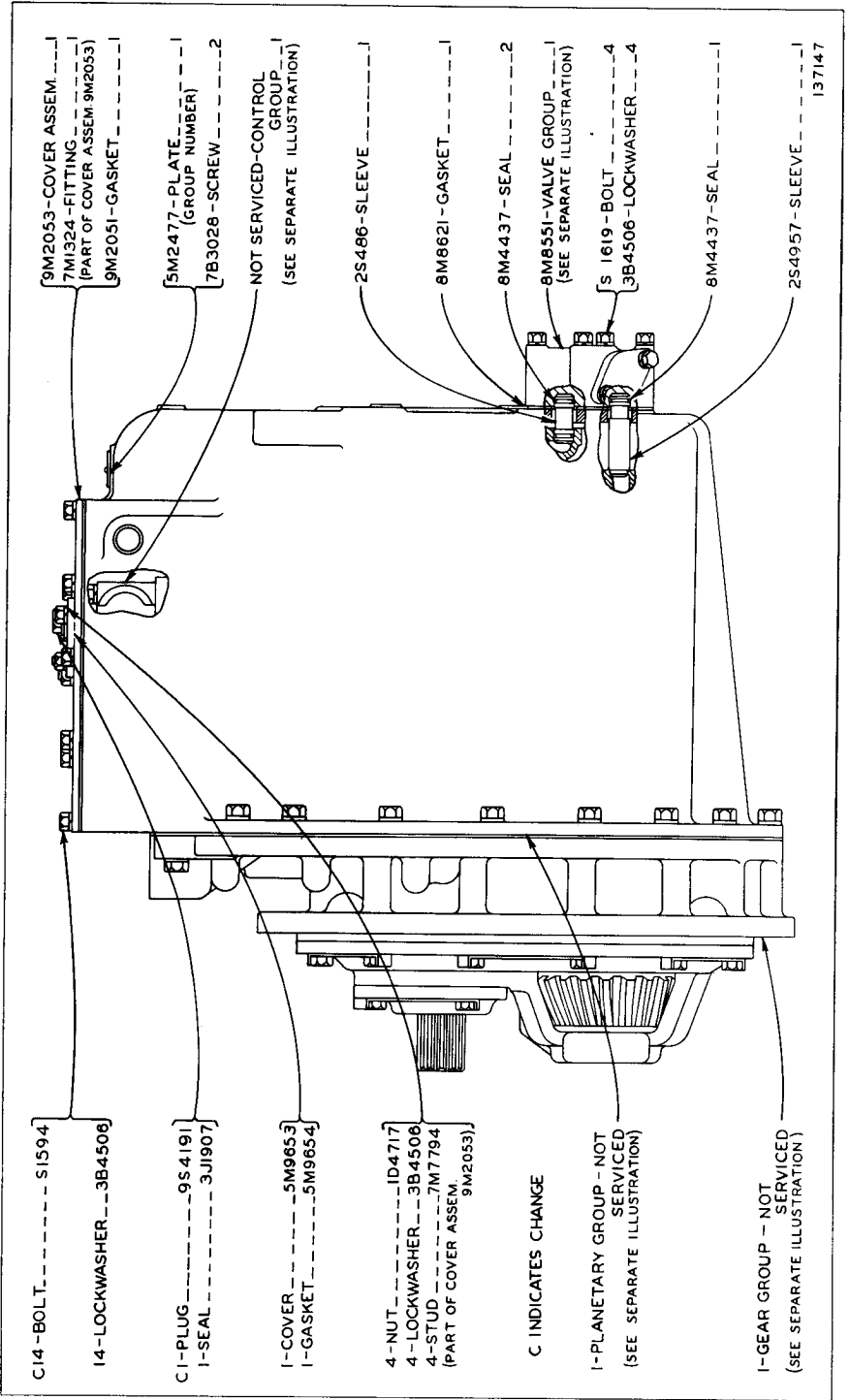

TRANSMISSION CONTROL LINKAGE (3S2037 N/S)

REF. NO.	PART NUMBER	DESCRIPTION	QTY
1	4M8799	SPRING	1
2	3S5008	LEVER	2
3	4B4280	WASHER	2
4	4B1280	SCREW	4
5	3S4644	GUIDE	1
6	7M706	KNOB	1
7	3S6058	ROD	1
8	1A912	WASHER	2
9	3B4607	COTTER PIN	2
10	3S5712	SHAFT	1
11	3B4617	COTTER PIN	2

REF. NO.	PART NUMBER	DESCRIPTION	QTY
29	4D4044	ROD END	4
30	4M496	BOLT	3
31	4M497	NUT	3
32	5B9079	NUT	5
33	3B1915	BOLT	1
34	1D4717	NUT	3
35	5H3895	BEARING	1
36	3K2366	ROD	3
37	1B8706	KEY	3
38	3S7337	LEVER	1
39	5S1588	BOLT	1
40	1S3585	LEVER	1

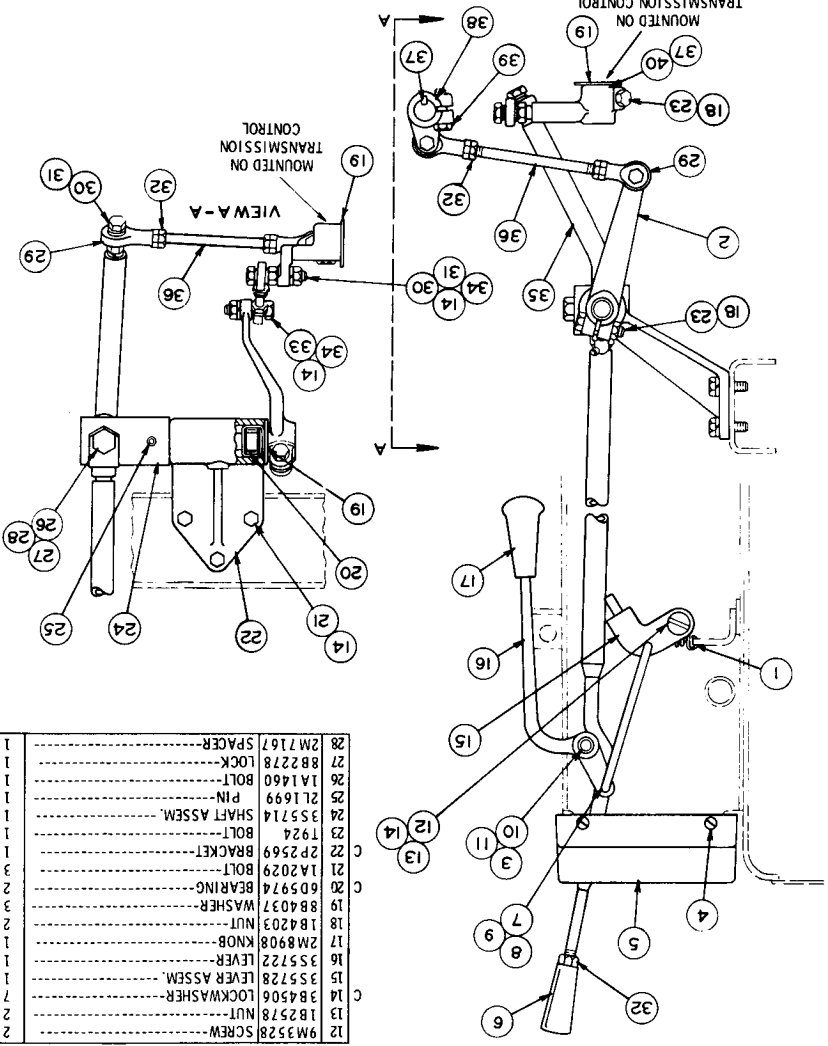

12	9M3528	SCREW	2
13	1B2578	NUT	2
14	3B4506	LOCKWASHER	7
15	3S5728	LEVER ASSEM.	1
16	3S5722	LEVER	1
17	2M8908	KNOB	1
18	1B4203	NUT	2
19	8B4037	WASHER	3
20	6D5974	BEARING	2
21	1A2029	BOLT	3
22	2P2569	BRACKET	1
23	1924	BOLT	1
24	3S5714	SHAFT ASSEM.	1
25	2L1699	PIN	1
26	1A1460	BOLT	1
27	8B2278	LOCK	1
28	2M7167	SPACER	1

C INDICATES CHANGE

138581





TRANSMISSION HYDRAULIC CONTROL (8M6350 N/S)  
 Serial No. 11K5780—Up, Test No. 30899—Up  
 Part of 3S2706 Range Transmission Arrangement shown on Page 57  
 1P6590 Control and 1P6591 Valve parts are shown on Pages 60A and 61

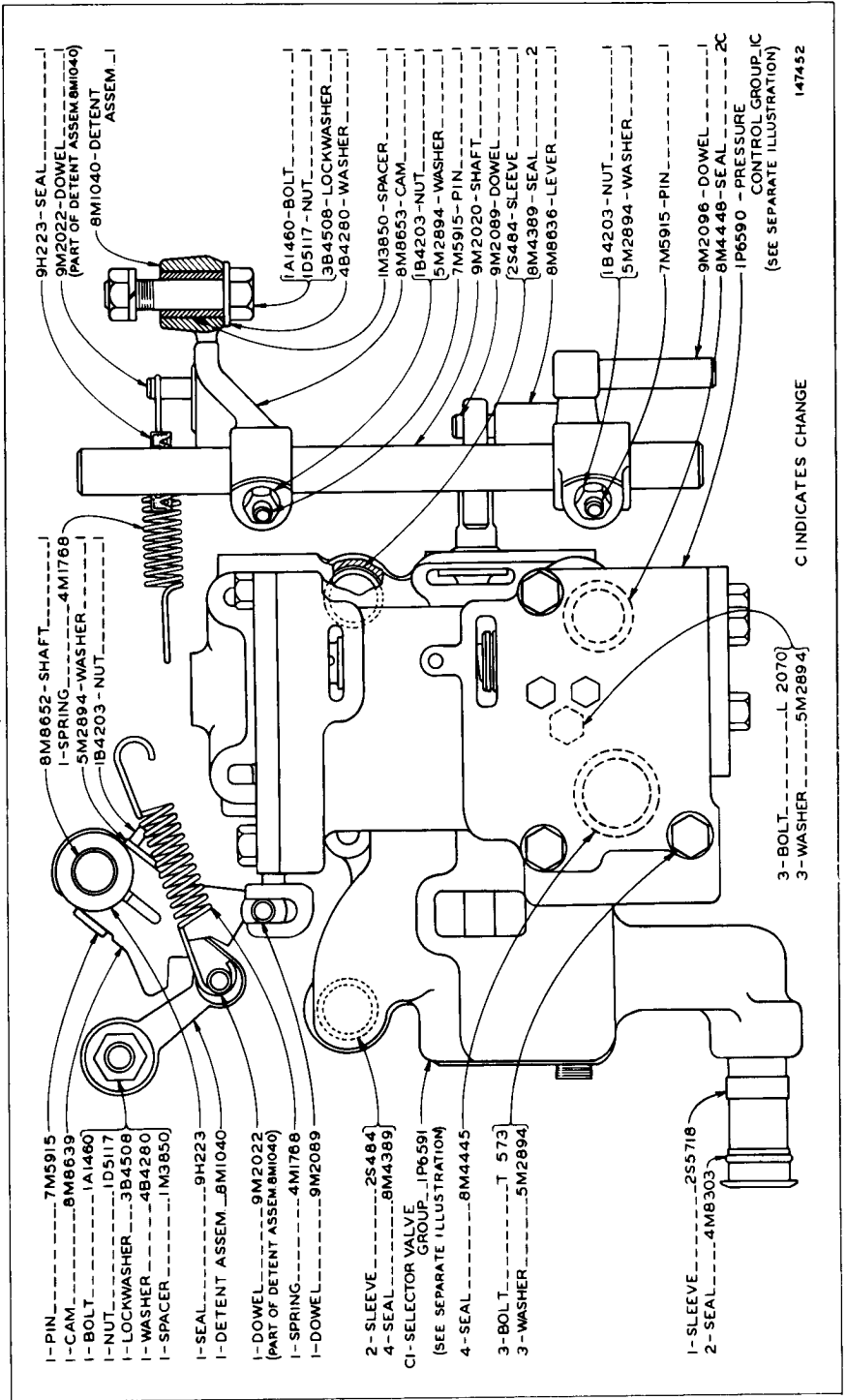

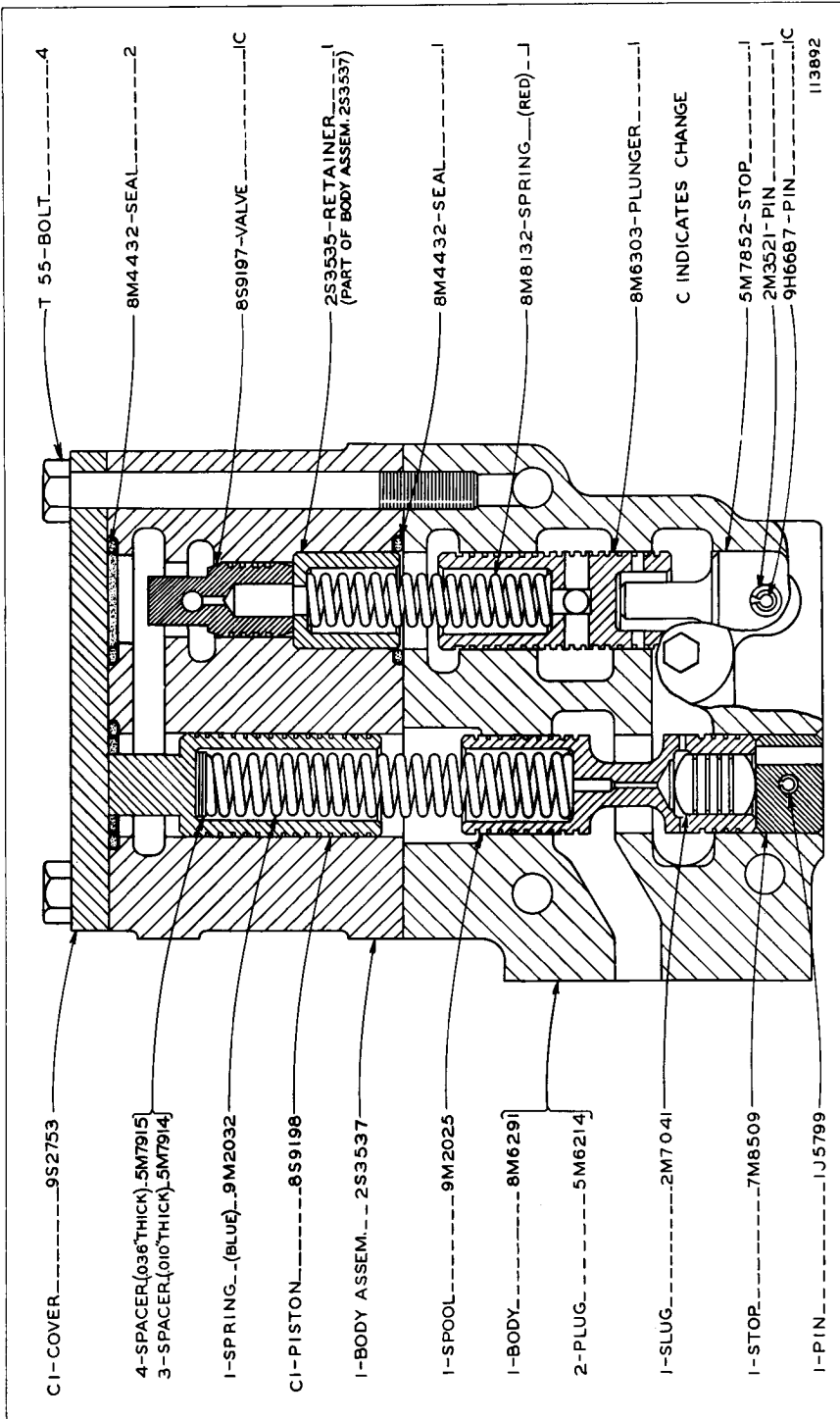

## 8M6349 PRESSURE CONTROL GROUP

Serial No. 11K5051 to 11K5779 inclusive

Part of Transmission Hydraulic Control shown on Page 59

Only separate parts serviced. When complete Group is required order 1P9674

1P6590 PRESSURE CONTROL GROUP  
 Serial No. 11K5780—Up, Test No. 30899—Up  
 Part of Transmission Hydraulic Control shown on Page 59B

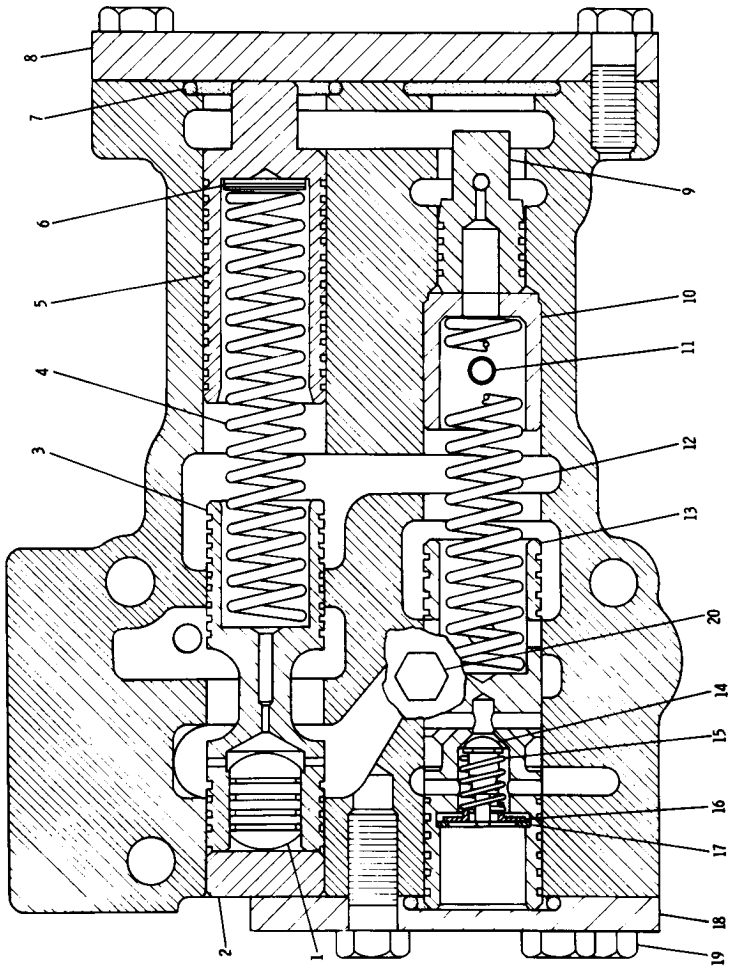

REF. NO.	PART NUMBER	DESCRIPTION	QTY
1	1ZM7041	SLUG	1
2	1P8612	STOP	1
3	9M2025	SPOOL	1
4	2P5744	SPRING	1
5	8S9198	PISTON	1
6	5M7915	SPACER—(.090 in. thick)	4
7	8M5248	SPACER—(.010 in. thick)	3
8	9S2753	COVER	1
9	8S9197	VALVE	1
10	1P9665	RETAINER	1
11	6D3036	DOWEL	2
12	8M8132	SPRING	1
13	1P6593	SPOOL ASSEM. (includes)	1
14	1S2121	PLUNGER	1
15	4M2381	SPRING	1
16	8S5508	RETAINER	1
17	2M8191	RING	1
18	1P8573	COVER	1
19	S1594	BOLT	7
20	5M6214	PLUG	2
C GM602516 FORM— (Installing Selector Valves and Pressure Controls)			1
C INDICATES CHANGE			150528

REF. NO.	PART NUMBER	DESCRIPTION	QTY
1	51594	BOLT	9
2	5M2894	WASHER	2
3	8M4433	SEAL	1
4	1P9666	COVER	1
5	9M2025	SPOOL	1
6	2P5744	SPRING	1
7	8S9198	PISTON	1
8	8M5248	SEAL	3
9	5M7914	SPACER--(.010 in. thick)	3
	5M7915	SPACER--(.036 in. thick)	4
10	9S2753	COVER	1
11	8S9197	VALVE	1
12	6D3036	DOWEL	2
13	1P9665	RETAINER	1
14	8M8132	SPRING	1
15	1P6593	SPOOL ASSEM. (includes)	1
16	152121	PLUNGER	1
17	4M2381	SPRING	1
18	8S508	RETAINER	1
19	2M8191	RING	1
20	1P8573	COVER	1
21	2M7041	SLUG	1
22	1P8612	STOP	1
	5M6214	PLUG	1
	4B9880	BALL	2
	GM602516	FORM (Installing Selector Valves and Pressure Controls)	1

▲ NOT SHOWN

15022

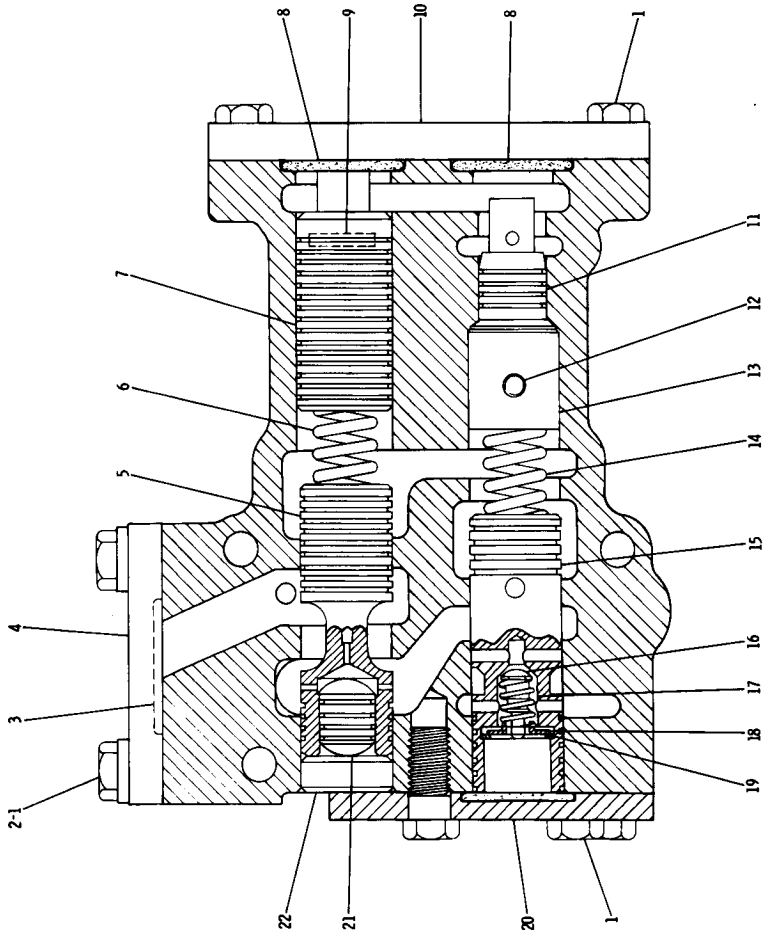

1P9674 PRESSURE CONTROL GROUP—Type 1  
 Provides Field Replacement for 8M6349 and 1P6590 Pressure Control Groups shown on Pages 60 and 60A

1P9674 PRESSURE CONTROL GROUP—Type 2  
 Provides Field Replacement for 8M6349 and 1P6590 Pressure Control Groups shown on Pages 60 and 60A

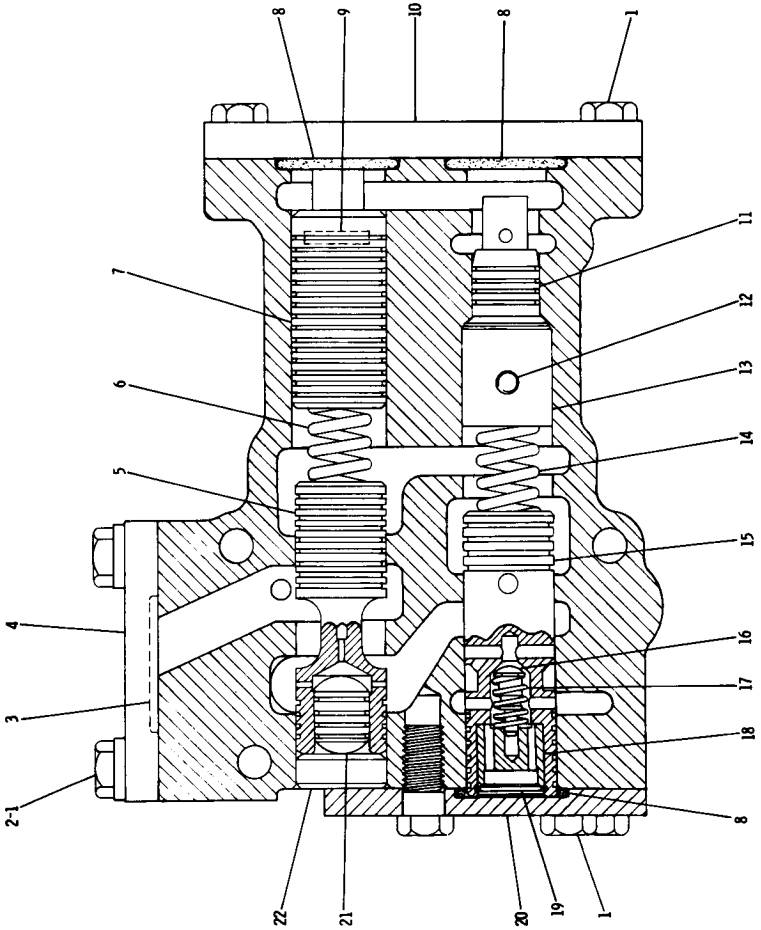

REF. NO.	PART NUMBER	DESCRIPTION	QTY
1	51594	BOLT	9
2	5M2894	WASHER	2
3	8M4433	SEAL	1
4	1P9666	COVER	1
5	9M2025	SPOOL	1
6	2P5744	SPRING	1
7	8S9198	PISTON	1
8	8M5248	SEAL	3
9	5M7914	SPACER—(.010 in. thick)	3
10	9S2753	COVER	1
11	8S9197	VALVE	1
12	6D3036	DOWEL	2
13	1P9665	RETAINER	1
14	8M8132	SPRING	1
15	6P4711	SPOOL ASSEM.	1
C	16 6P8848	(Includes) PLUNGER	1
	17 9H2367	SPRING	1
	18 6P4717	SLEEVE	1
	19 2M8191	RING	1
	20 1P8573	COVER	1
	21 2M7041	SLUG	1
	22 1P8612	STOP	1
	▲ 5M6214	PLUG	2
	▲ 4B9880	BALL	2
C	GM602516	FORM—(Installing Selector Valves and Pressure Controls)	1

▲ NOT SHOWN

152757

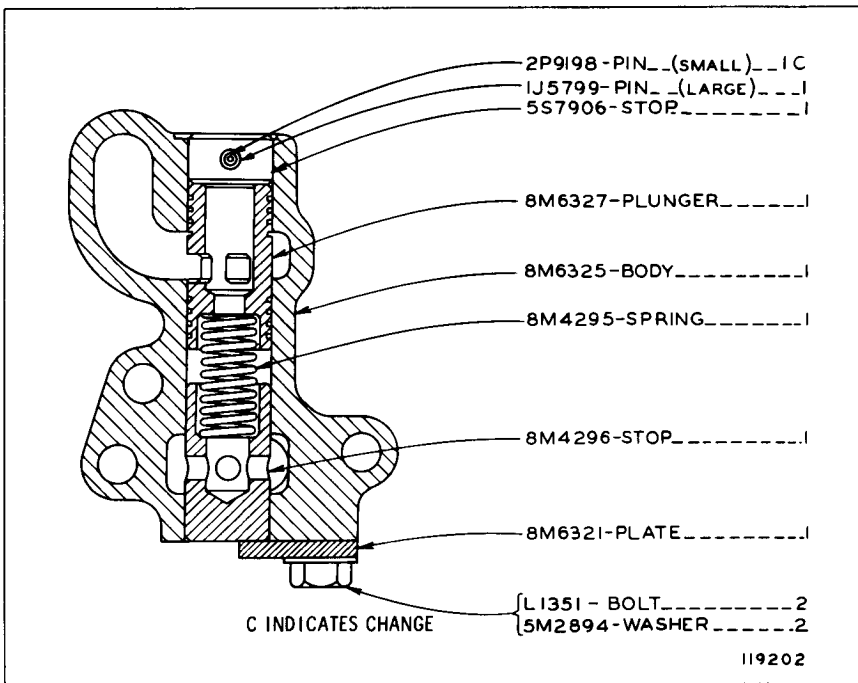

**8M6347 FLOW CONTROL VALVE GROUP**  
 Serial No. 11K5051 to 11K5779 inclusive  
 Part of Transmission Hydraulic Control shown on Page 59

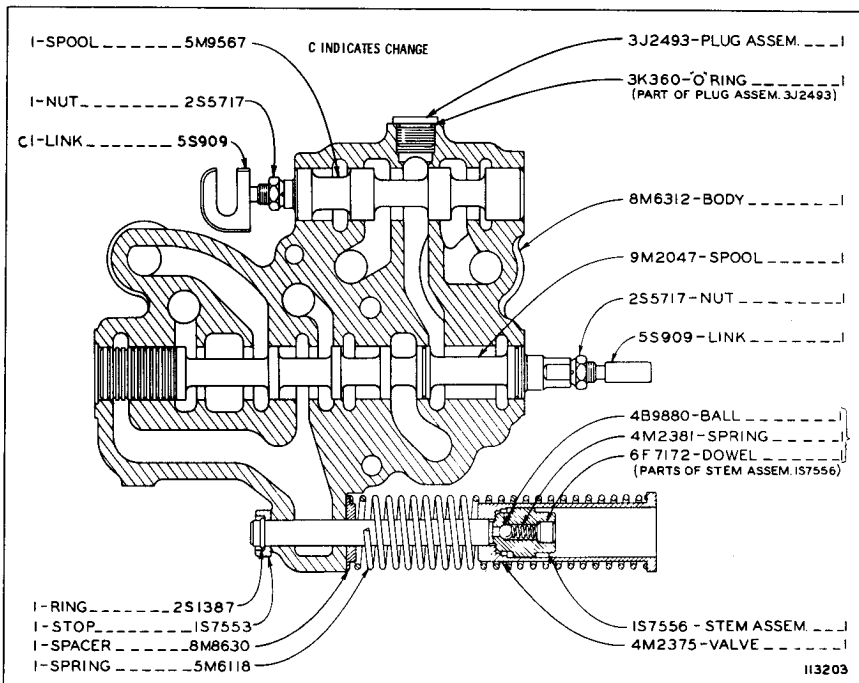

**8M6348 SELECTOR AND SAFETY VALVE GROUP**  
 Serial No. 11K5051 to 11K5779 inclusive  
 Part of Transmission Hydraulic Control shown on Page 59

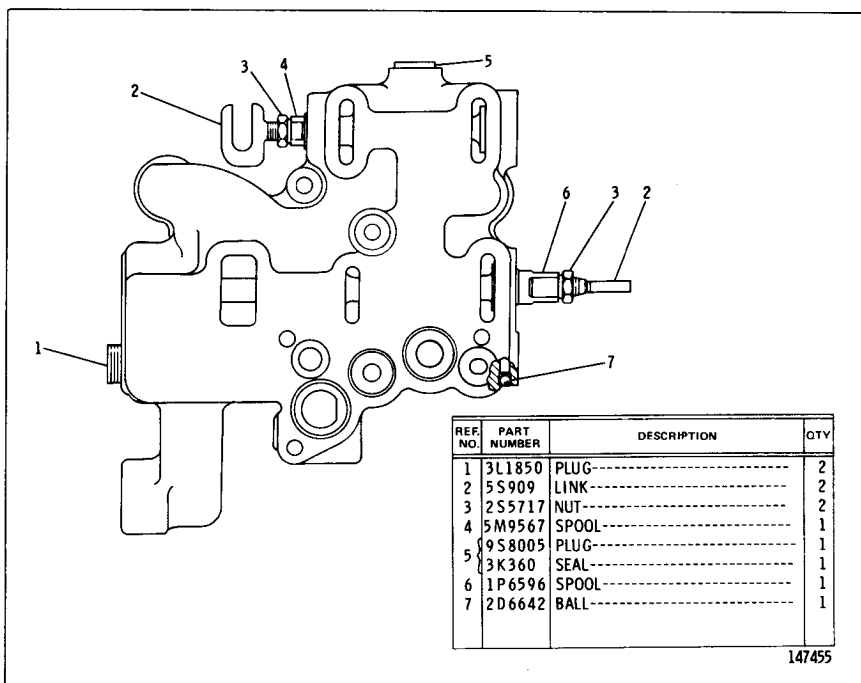

**1P6591 SELECTOR VALVE GROUP**  
 Serial No. 11K5780—Up. Test No. 30899—Up  
 Part of Transmission Hydraulic Control shown on Page 59B

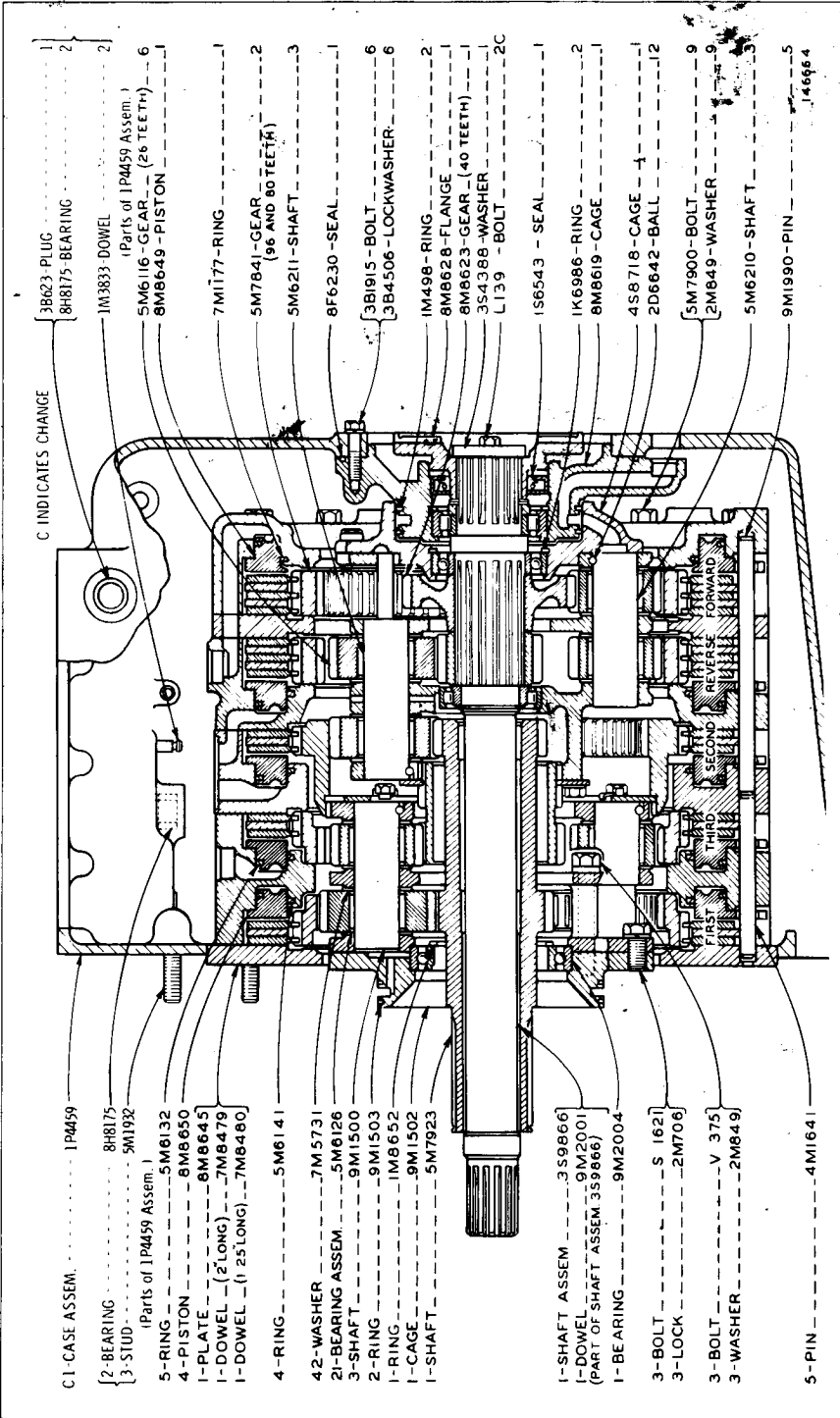

PLANETARY TRANSMISSION (9M2040 N/S)—Part 1  
 Part of 3S2706 Range Transmission Arrangement shown on Page 57



PLANETARY TRANSMISSION (9M2040 N/S)—Part 2  
 Part of 3S2706 Range Transmission Arrangement shown on Page 57

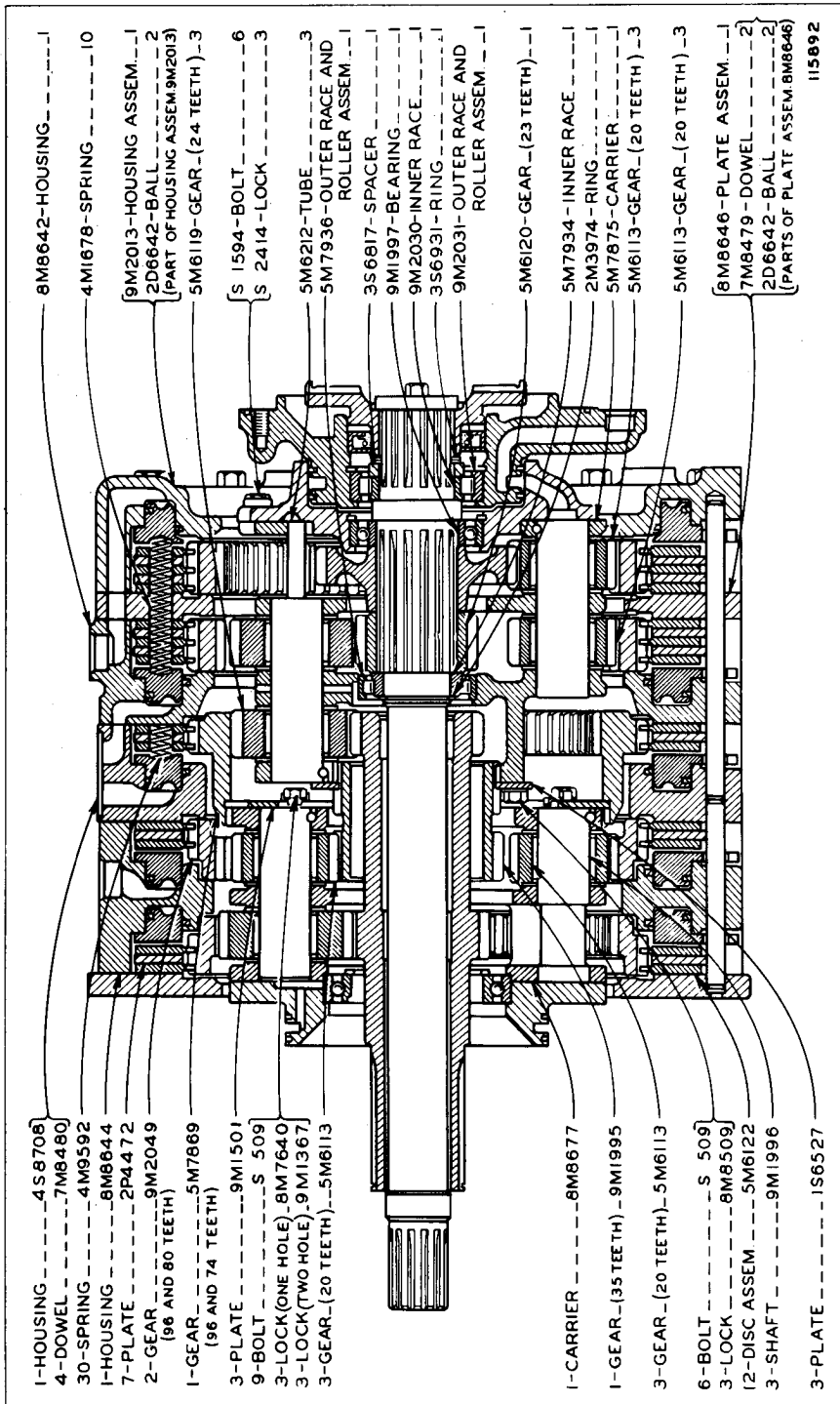

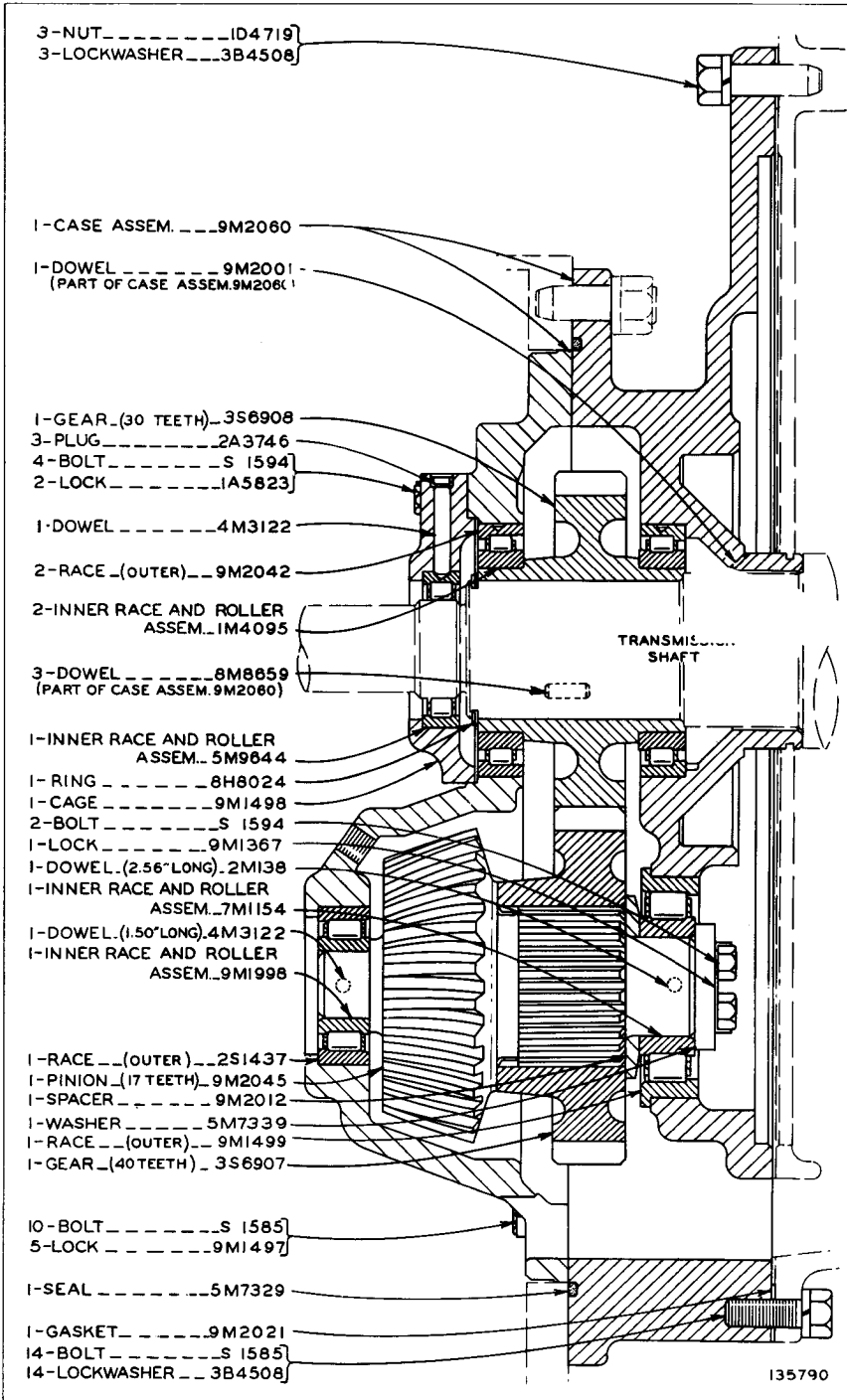

## TRANSFER GEARS (3S6922 N/S)

Part of 3S2706 Range Transmission Arrangement shown on Page 57

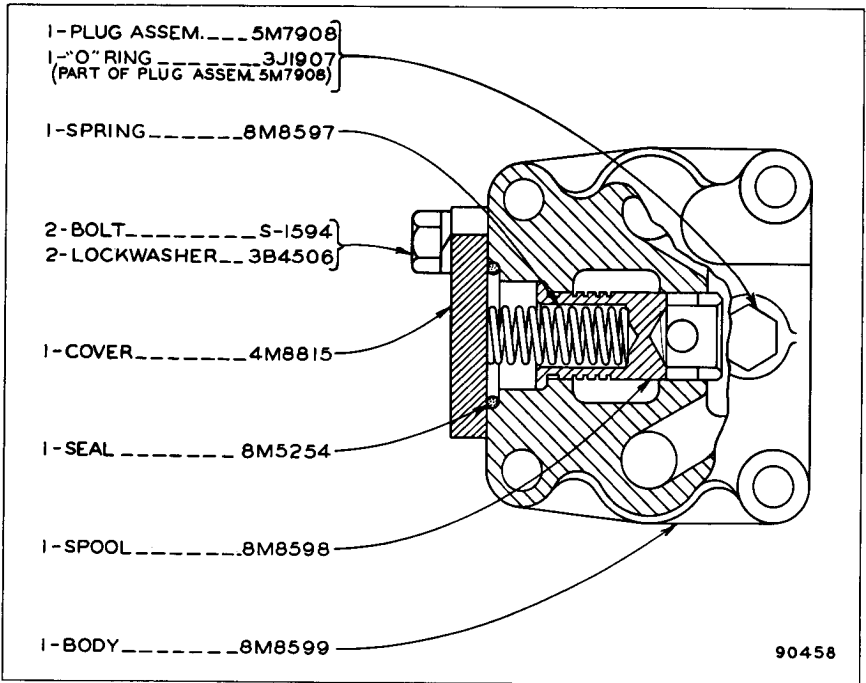

**8M8551 RELIEF VALVE GROUP**

Part of 3S2706 Range Transmission Arrangement shown on Page 57

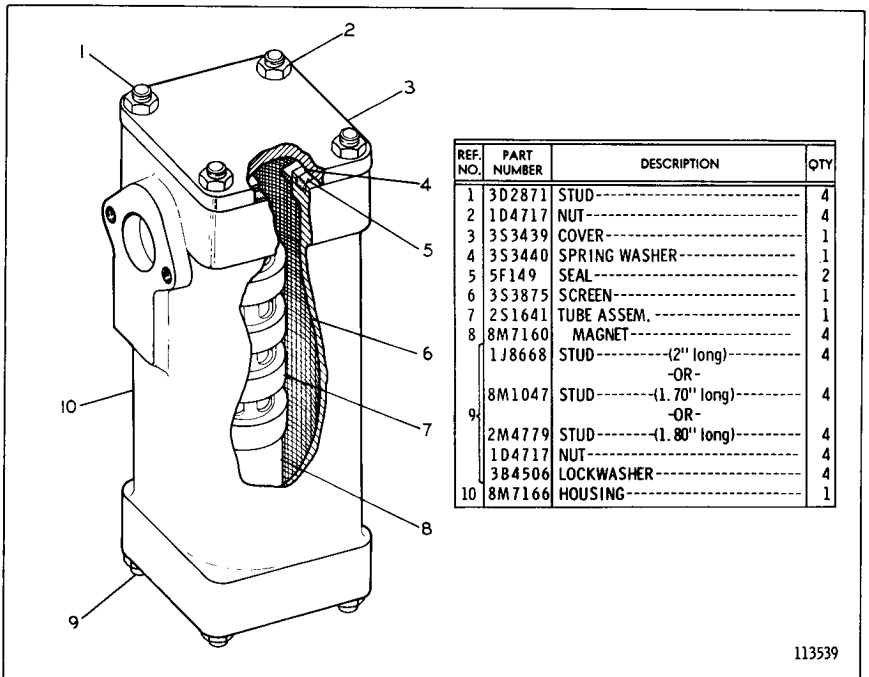

**9M8669 MAGNETIC SCREEN GROUP**

Part of Transmission & Steering Clutch Lubrication System shown on Pages 67, 70, 73 & 76

REF. NO.	PART NUMBER	DESCRIPTION	QTY
C 1	8M4986	SEAL.....	1
C 2	3H5368	BOLT.....	4
C 3	3B4507	LOCKWASHER.....	4
C 4	1P7585	TUBE ASSEM. (Relief Valve to Ref. No. 21)	1
C 5	1P3303	TUBE ASSEM.....	1
C 6	2S7070	JOINT ASSEM.....	3
C 7	9S2082	SEAL ASSEM.....	2
C 8	7S7281	CLAMP.....	2
C 9	L1351	BOLT.....	3
C 10	3B4506	LOCKWASHER.....	30
C 11	1P3294	TUBE ASSEM.....	1
C 12	8M4987	SEAL.....	7

C 11	3B1915	BOLT.....(L.375" long)	12
C 12	1P3290	TUBE ASSEM.....	1
C 13	7S3916	CLIP.....(Tab)	1
C 14	7S3919	CLIP.....	1

15	1P3633	TUBE ASSEM.....	1
16	9S4191	PLUG.....	1
17	3J1907	SEAL.....	1
C 17	4B4278	WASHER.....	3
C 18	1P3306	TUBE ASSEM.....	1
C 19	2F6578	CLAMP.....	2
C 20	S1616	BOLT.....	1
C 21	1B4330	NUT.....	1
C 21	3B4504	LOCKWASHER.....	1
C 21	1P3676	VALVE GROUP (Separate Illustration)	1
C 22	2A4639	BOLT.....(L.625" long)	12
C 23	1P7587	TUBE ASSEM.....	1
C 24	1P7589	TUBE ASSEM.....	1
C 25	S1571	BOLT.....	2
C 26	1D4717	NUT.....	4

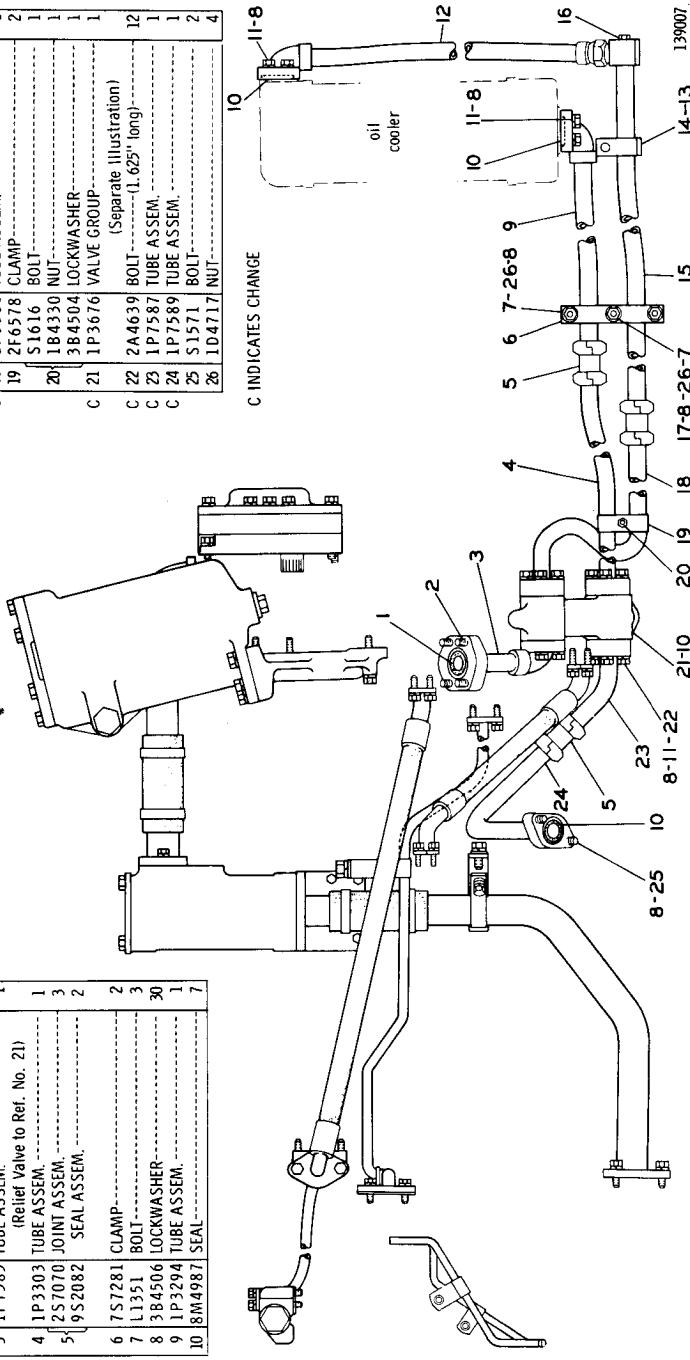

TRANSMISSION AND STEERING CLUTCH LUBRICATION SYSTEM (7S7401 N/S)—Part 1 of 3

Serial No. 11K5051 to 11K5061 inclusive  
 1P3676 Valve parts are shown on Page 79

TRANSMISSION AND STEERING CLUTCH LUBRICATION SYSTEM (7S7401 N/S)—Part 2 of 3  
 Serial No. 11K5051 to 11K5061 inclusive  
 9M8669 Screen and 1S6520 Pump parts are shown on Pages 65 & 79

REF. NO.	PART NUMBER	DESCRIPTION	QTY
1	9M8669	SCREEN GROUP— (Separate Illustration)	1
2	1A 2029	BOLT	7
3	3B4506	LOCKWASHER	14
4	3S3703	TUBE ASSEM.	1
5	9M164	CLAMP	4
6	1S4018	HOSE	2
7	3S3740	TUBE ASSEM.	1

8	S1588	BOLT	5
9	1S6520	PUMP GROUP— (Separate Illustration)	1
10	8M5007	SEAL	1
11	8M4992	SEAL	1
12	8M4987	SEAL	1
13	3S3708	TUBE ASSEM.	1
14	6H1717	BOLT	1
14	3B4508	LOCKWASHER	1
15	4B4280	WASHER	1
16	3S3698	TUBE ASSEM.	1
16	8M4390	SEAL	1
17	S1594	BOLT	2
17	1D4717	NUT	2
18	4B4278	WASHER	2
18	2H8930	CLAMP	2
19	3S3676	BRACKET	1
20	8M4436	SEAL	2

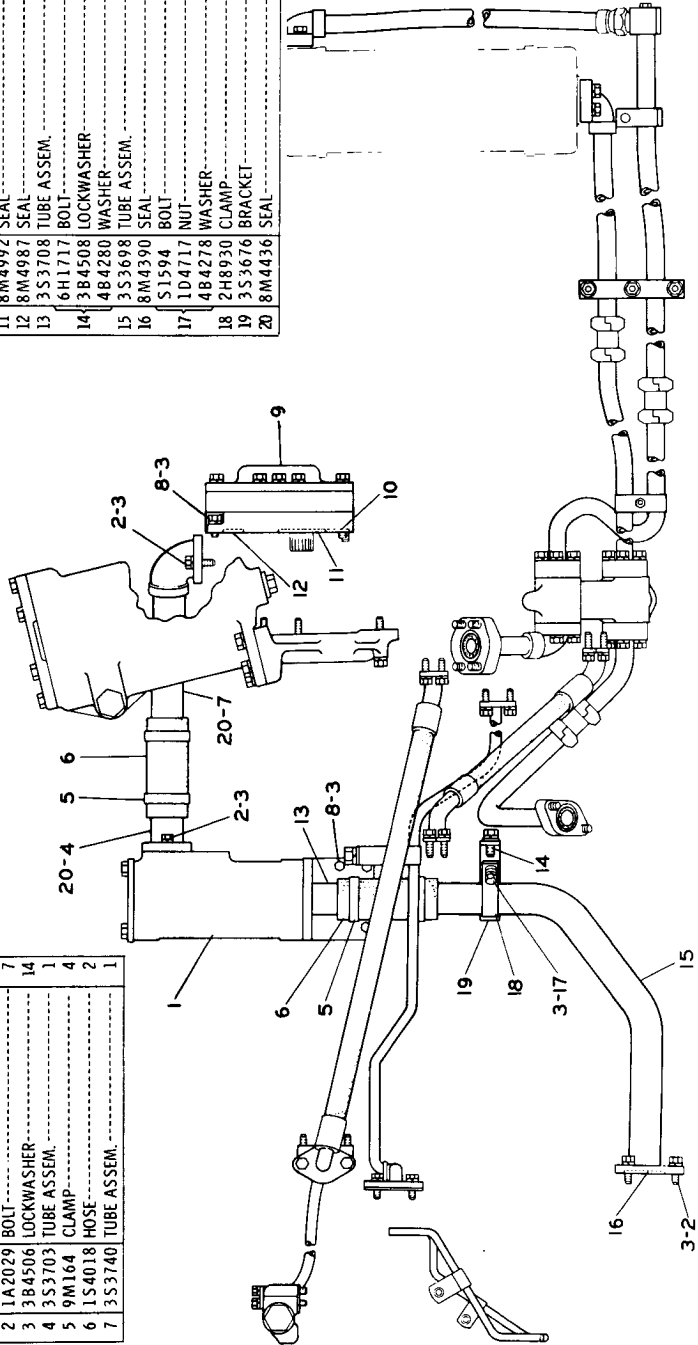

REF. NO.	PART NUMBER	DESCRIPTION	QTY
1	1P1899	VALVE GROUP (See Separate Illustration)	1
2	8M4445	SEAL	1
	589603	BOLT-----(.5" long)	1
	L1143	BOLT-----(.2.5" long)	1

▲ ORDER BY THE FOOT

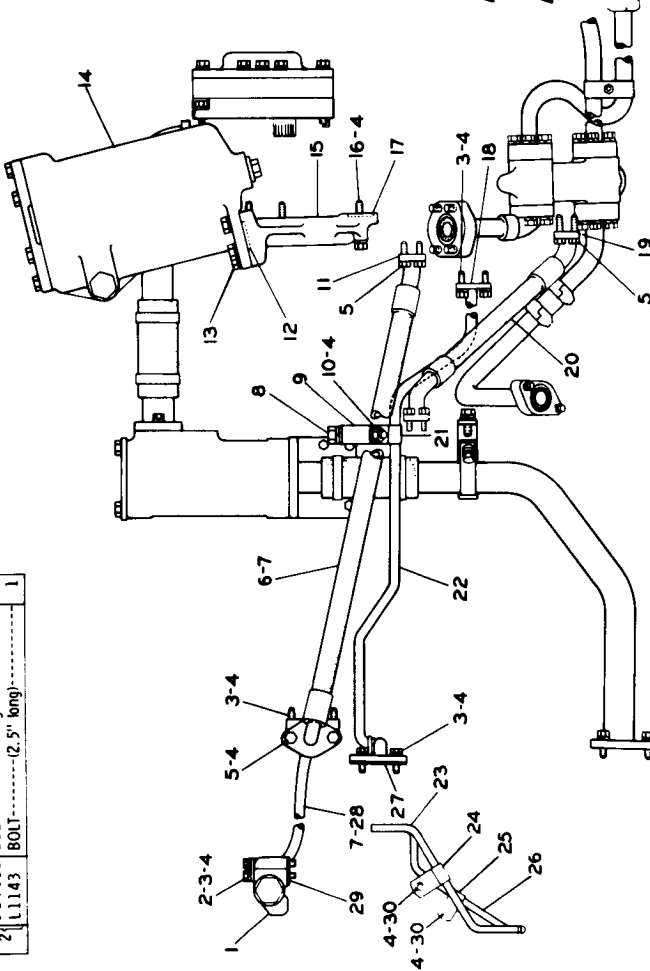

3	1A2029	BOLT-----(.125" long)	8
4	3B4506	LOCKWASHER	20
5	S1588	BOLT	14
6	9S2693	HOSE ASSEM. ....(27" long)	1
7	8M4987	SEAL	3
	S1624	BOLT	1
8	3B4510	LOCKWASHER	1
	4B4281	WASHER	1
9	3S5716	BRACKET	1
	S1594	BOLT	1
10	1D4717	NUT	1
	4B4278	WASHER	1
11	1P4577	FLANGE	2
12	8M4986	SEAL	2
	S1585	BOLT	5
13	3B4508	LOCKWASHER	5
14	8S666	FILTER GROUP (Separate Illustration)	1
15	3S9845	SUPPORT	1
16	L2070	BOLT-----(.2.25" long)	4
	3B1915	BOLT-----(.1.375" long)	1
17	8M5254	SEAL	2
	9M9037	FLANGE	1
18	1S4	SEAL	1
19	1P4576	FLANGE	4
	3S3711	HOSE ASSEM. ....(.15.75" long)	1
20	8M4988	SEAL	2
21	8E2395	CLIP	1
22	3S3737	TUBE ASSEM.	1
23	4S8457	TUBE---(Bevel Gear Oiling)---13.13"	1
24	7B1597	CLIP	1
25	7B9919	CLIP	1
26	4S8457	TUBE---13.35"	1
27	1F3133	GASKET	1
28	3S2053	TUBE ASSEM.	1
29	8M4448	SEAL	1
30	T102	BOLT	2

119189

TRANSMISSION AND STEERING CLUTCH LUBRICATION SYSTEM (7S7401 N/S)—Part 3 of 3

Serial No. 11K5051 to 11K5061 inclusive

1P1899 Valve and 8S666 Filter parts are shown on Pages 78 & 82

TRANSMISSION AND STEERING CLUTCH LUBRICATION SYSTEM (7S7401 N/S)—Part 1 of 3  
 Serial No. 11K5062 to 11K5068 inclusive  
 1P3676 Valve parts are shown on Page 79

REF. NO.	PART NUMBER	DESCRIPTION	QTY
1	8M4986	SEAL	1
2	3H5368	BOLT	4
3	3B4507	LOCKWASHER	4
4	1P7585	TUBE ASSEM. (Relief Valve to Ref. No. 21)	1
5	1P3303	TUBE ASSEM.	1
6	2S7070	JOINT ASSEM.	3
7	9S2082	SEAL ASSEM.	2
8	7S7281	CLAMP	2
9	L1351	BOLT	3
10	3B4506	LOCKWASHER	30
11	1P3294	TUBE ASSEM.	1
12	8M4987	SEAL	7

11	3B1915	BOLT	12
12	1P3290	TUBE ASSEM.	1
13	7S3916	CLIP	1
14	7S3919	CLIP	1

15	1P3633	TUBE ASSEM.	1
16	9S4191	PLUG	1
17	3J1907	SEAL	1
18	4B4278	WASHER	3
19	1P3306	TUBE ASSEM.	1
20	2F6578	CLAMP	2
21	S1616	BOLT	1
22	1B4330	NUT	1
23	3B4504	LOCKWASHER	1
24	1P3676	VALVE GROUP (Separate Illustration)	1
25	2A4639	BOLT	12
26	1P7587	TUBE ASSEM.	1
27	1P7589	TUBE ASSEM.	1
28	S1571	BOLT	2
29	104717	NUT	4

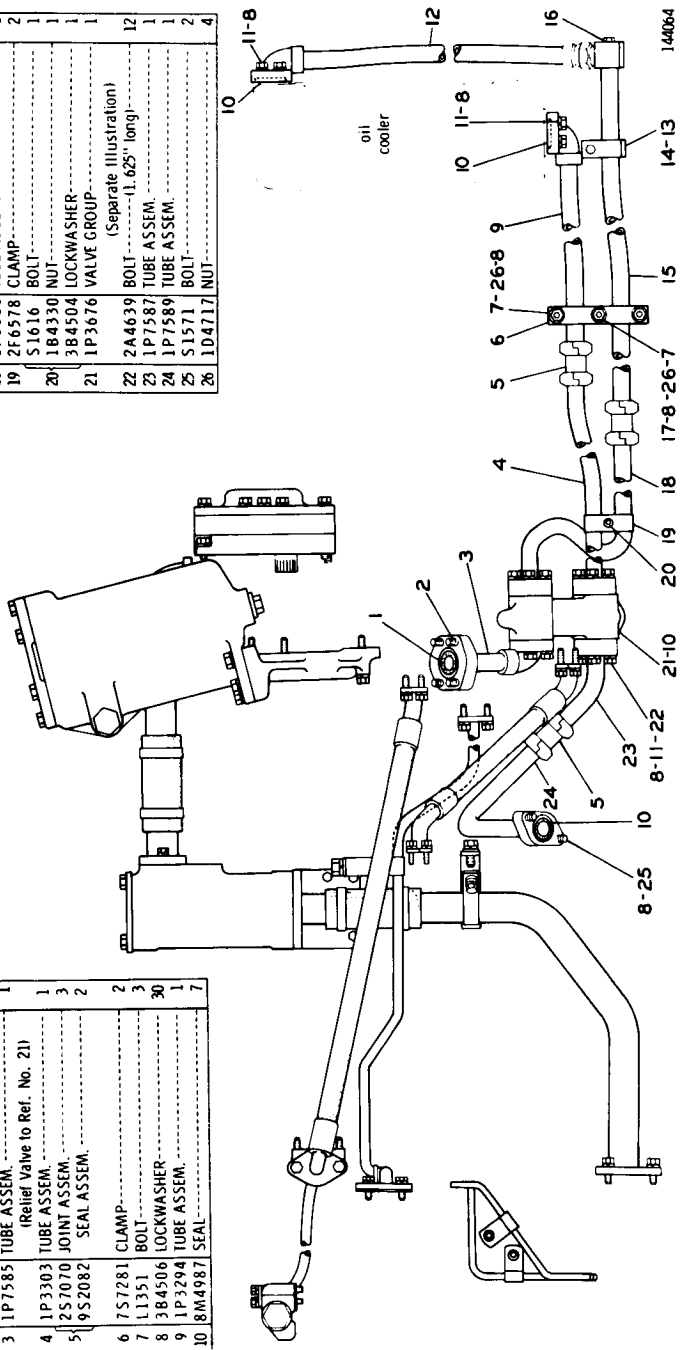

REF NO.	PART NUMBER	DESCRIPTION	QTY
1	9M8669	SCREEN GROUP (Separate Illustration)	1
2	1A2029	BOLT	7
3	3B4506	LOCKWASHER	14
4	3S3703	TUBE ASSEM.	1
5	9M164	CLAMP	4
6	1S4018	HOSE	2
7	3S3740	TUBE ASSEM.	1

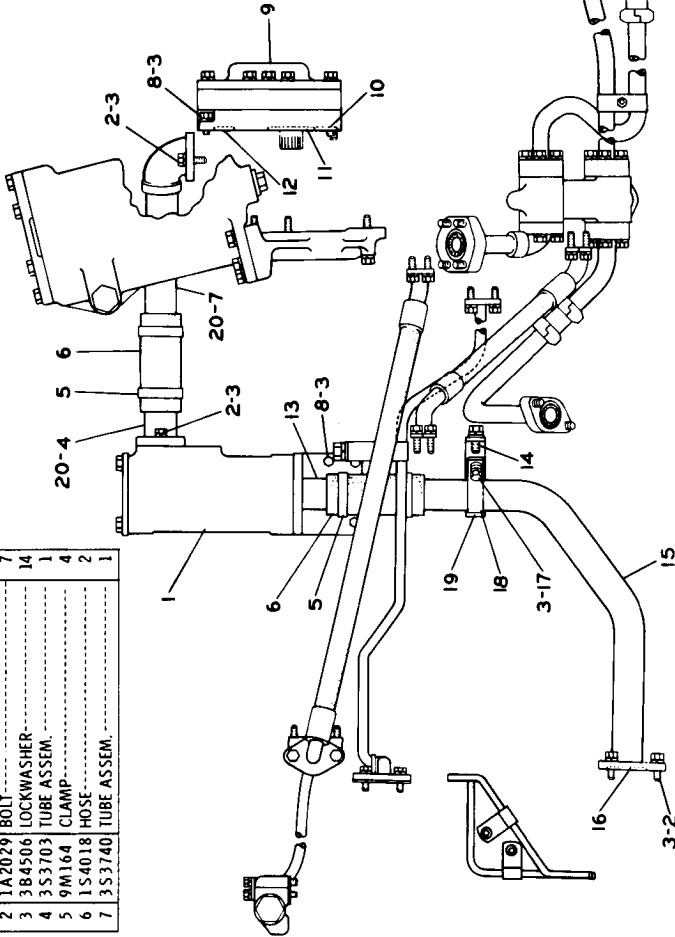

8	S1588	BOLT	5
9	1S6520	PUMP GROUP (Separate Illustration)	1
10	8M5007	SEAL	1
11	8M4992	SEAL	1
12	8M4987	SEAL	1
13	3S3708	TUBE ASSEM.	1
14	6H1717	BOLT	1
14	3B4508	LOCKWASHER	1
15	4B4280	WASHER	1
15	3S3698	TUBE ASSEM.	1
16	8M4390	SEAL	1
17	S1594	BOLT	2
17	1D4717	NUT	2
18	4B4278	WASHER	2
18	2H8930	CLAMP	2
19	3S3676	BRACKET	1
20	8M4436	SEAL	1
			2

144065

TRANSMISSION AND STEERING CLUTCH LUBRICATION SYSTEM (7S7401 N/S)—Part of 3  
 Serial No. 11K5062 to 11K5068 inclusive  
 9M8669 Screen and 1S6520 Pump parts are shown on Pages 65 & 79



TRANSMISSION AND STEERING CLUTCH LUBRICATION SYSTEM (7S7401 N/S)—Part 3 of 3  
 Serial No. 11K5062 to 11K5068 inclusive  
 1P1899 Valve and 8S666 Filter parts are shown on Pages 78 & 82

REF. NO.	PART NUMBER	DESCRIPTION	QTY
1	1P1899	VALVE GROUP— (See Separate Illustration)	1
1	8M4445	SEAL— .....(5" long).....	1
1	5B9603	BOLT— .....(2.5" long).....	1
2	L1143	BOLT— .....(2.5" long).....	1

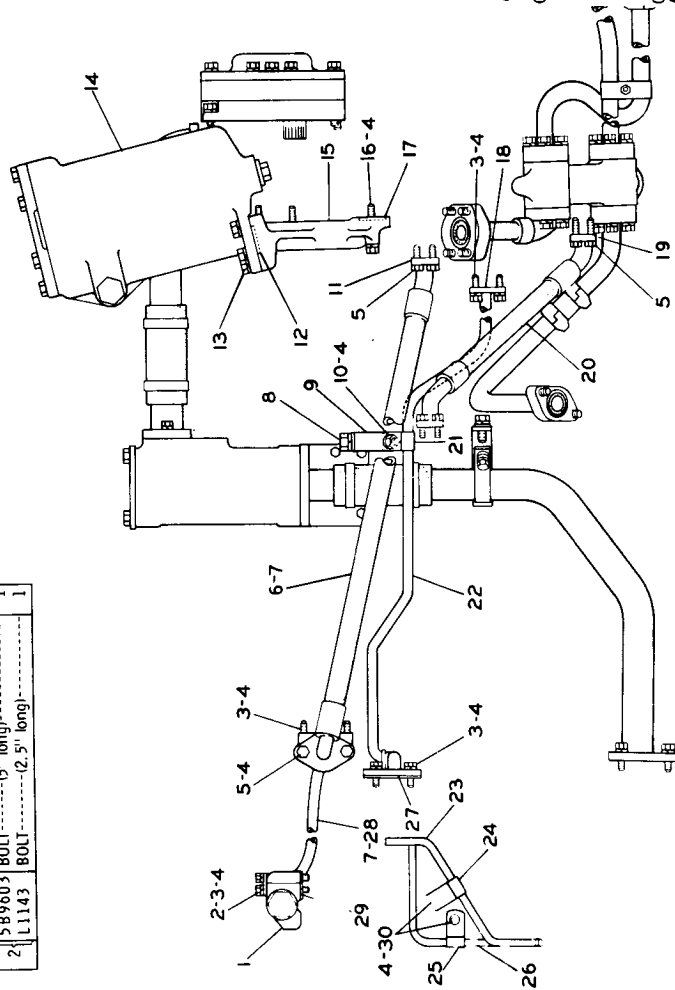

3	1A2029	BOLT— .....(1.125" long).....	8
4	3B4506	LOCKWASHER.....	20
5	S1588	BOLT.....	14
6	9S2693	HOSE ASSEM. ....(27" long)	1
7	8M4987	SEAL.....	3
8	S1624	BOLT.....	1
8	3B4510	LOCKWASHER.....	1
9	4B4281	WASHER.....	1
9	3S5716	BRACKET.....	1
10	S1594	BOLT.....	1
10	1D4717	NUT.....	1
11	4B4278	WASHER.....	1
11	1P4577	FLANGE.....	2
12	8M4986	SEAL.....	2
13	S1585	BOLT.....	5
13	3B4508	LOCKWASHER.....	5
14	8S666	FILTER GROUP..... (Separate Illustration)	1
15	3S9845	SUPPORT.....	1
16	L2070	BOLT— .....(2.25" long).....	4
16	3B1915	BOLT— .....(1.375" long).....	1
17	8M5254	SEAL.....	2
18	9M9037	FLANGE.....	1
18	1S4	SEAL.....	1
19	1P4576	FLANGE.....	4
19	3S3711	HOSE ASSEM. ....(15.75" long).....	1
20	8M4988	SEAL.....	2
21	8F2395	CLIP.....	1
22	3S3737	TUBE ASSEM. ....(Revel Gear Oiling).....	1
23	4S8457	TUBE.....(Revel Gear Oiling).....(13.13" long)	1
24	7B1597	CLIP.....	1
25	8B6127	CLIP.....	1
26	2P9346	TUBE.....	1
27	1F3133	GASKET.....	1
28	3S2053	TUBE ASSEM. ....	1
29	8M4448	SEAL.....	1
30	T1102	BOLT.....	2

C INDICATES CHANGE  
 ▲ ORDER BY THE FOOT

REF. NO.	PART NUMBER	DESCRIPTION	QTY
1	8M4986	SEAL	1
2	3H5368	BOLT	4
3	3B4507	LOCKWASHER	4
4	1P3303	TUBE ASSEM. (Relief Valve to Ref. No. 21)	1
5	2S7070	JOINT ASSEM.	3
	9S2082	SEAL ASSEM.	2
6	7S7281	CLAMP	2
7	L1351	BOLT	3
8	3B4506	LOCKWASHER	30
9	1P3294	TUBE ASSEM.	1
10	8M4987	SEAL	7

11	3B1915	BOLT	(L. 3.75" long)	12
12	1P3290	TUBE ASSEM.	(Tab)	1
13	7S3916	CLIP		1
14	7S3919	CLIP		1

15	1P3633	TUBE ASSEM.	
	9S4191	PLUG	1
16	3J1907	SEAL	1
17	4B4278	WASHER	3
18	1P3306	TUBE ASSEM.	1
19	2F6578	CLAMP	2
	S1616	BOLT	1
20	1B4350	NUT	1
	3B4504	LOCKWASHER	1
21	1P3676	VALVE GROUP	1
22	2A4639	BOLT	(Separate Illustration) (L. 0.625" long)
23	1P7587	TUBE ASSEM.	12
24	1P7589	TUBE ASSEM.	1
25	S1571	BOLT	1
26	1D4717	NUT	2
			4

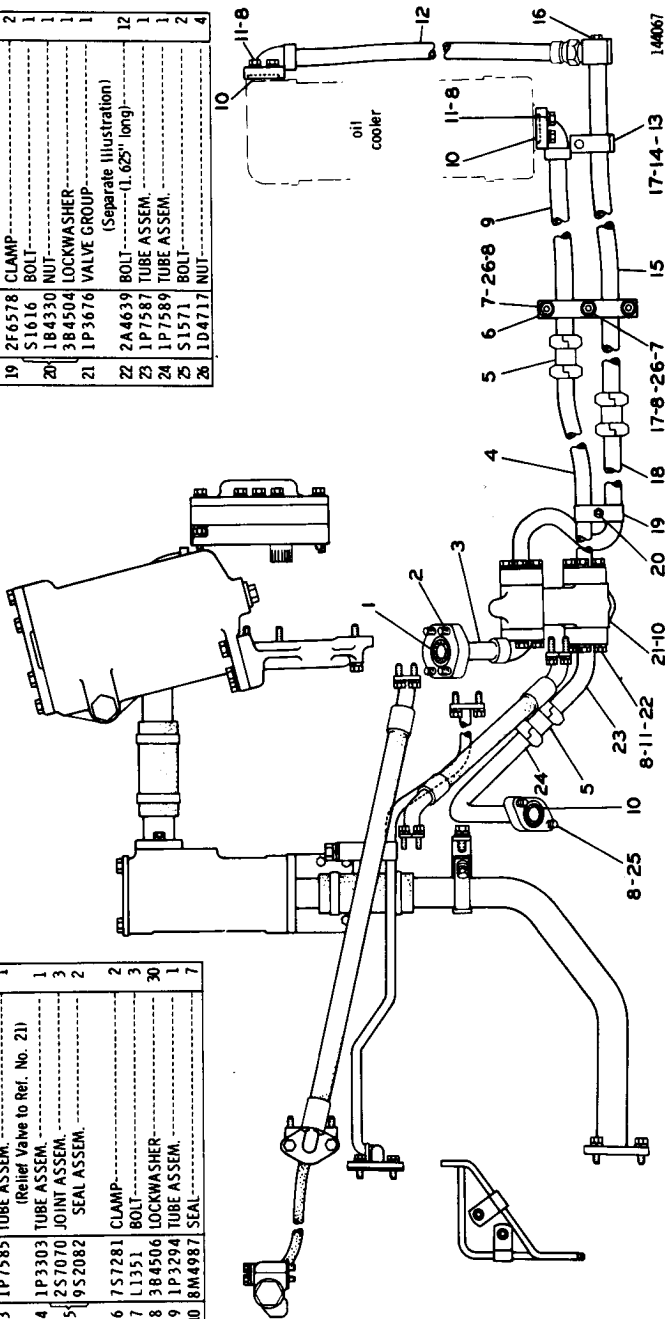

TRANSMISSION AND STEERING CLUTCH LUBRICATION SYSTEM (7S7401 N/S)—Part 1 of 3  
 Serial No. 11K5069 to 11K5083 inclusive  
 1P3676 Valve parts are shown on Page 79

TRANSMISSION AND STEERING CLUTCH LUBRICATION SYSTEM (7S7401 N/S)—Part 2 of 3  
 Serial No. 11K5069 to 11K5083 inclusive

9M8669 Screen and 1S6520 Pump parts are shown on Pages 65 & 79

REF. NO.	PART NUMBER	DESCRIPTION	QTY
1	9M8669	SCREEN GROUP— (Separate Illustration)	1
2	1A2029	BOLT—	7
3	3B4506	LOCKWASHER—	14
4	3S3703	TUBE ASSEM.—	1
5	1P6261	CLAMP—	4
6	1S4018	HOSE—	2
7	3S3740	TUBE ASSEM.—	1

8	51588	BOLT—	5
9	1S6520	PUMP GROUP— (Separate Illustration)	1
10	8M5007	SEAL—	1
11	8M4992	SEAL—	1
12	8M4987	SEAL—	1
13	3S3708	TUBE ASSEM.—	1
14	6H1717	BOLT—	1
14	3B4508	LOCKWASHER—	1
14	4B4280	WASHER—	1
15	3S3698	TUBE ASSEM.—	1
16	8M4390	SEAL—	1
17	51594	BOLT—	2
17	1D4717	NUT—	2
18	2H8930	CLAMP—	1
19	3S3676	BRACKET—	1
20	8M4436	SEAL—	2

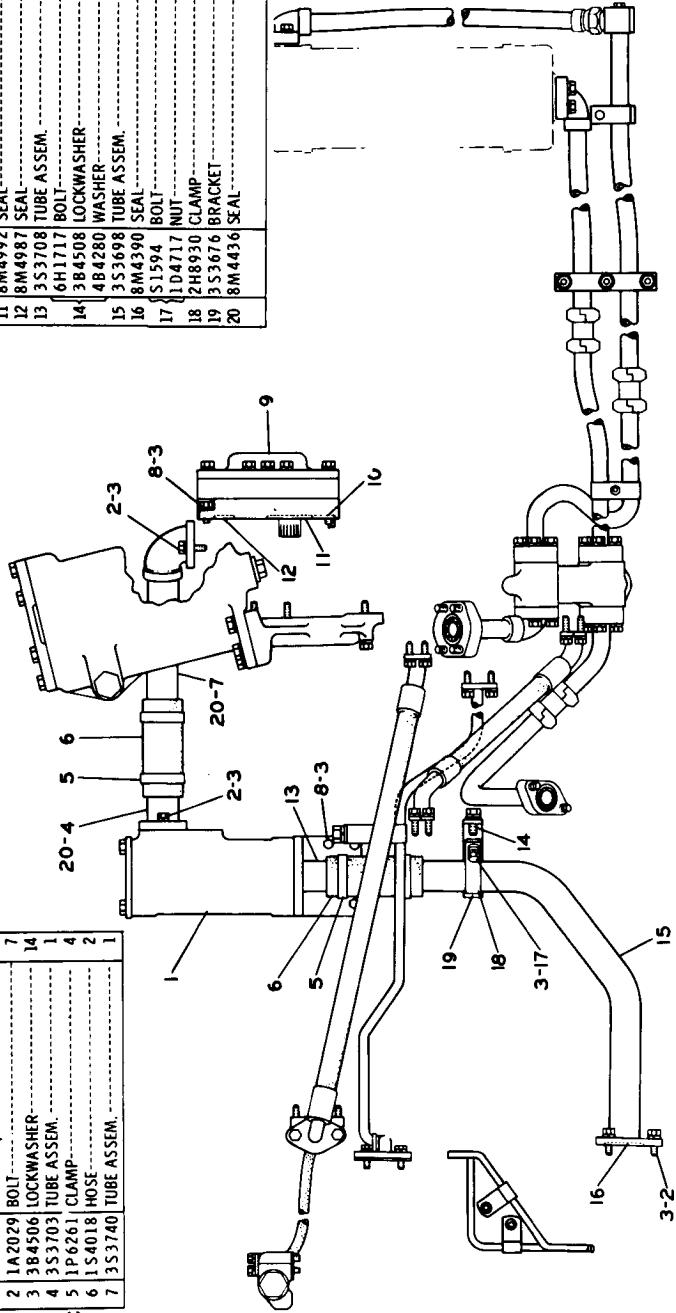

C INDICATES CHANGE

144068

REF. NO.	PART NUMBER	DESCRIPTION	QTY
1	1P1899	VALVE GROUP (Separate Illustration)	1
2	8M4445	SEAL (Separate Illustration)	1
3	5B9603	BOLT (5 in. Long)	1
4	1L143	BOLT (2.5 in. Long)	1
5	1A2029	BOLT (1.125 in. Long)	8
6	3B4506	LOCKWASHER	20
7	S1588	BOLT (27 in. Long)	14
8	9S2693	HOSE ASSEM. (27 in. Long)	1
9	8M4987	SEAL	3

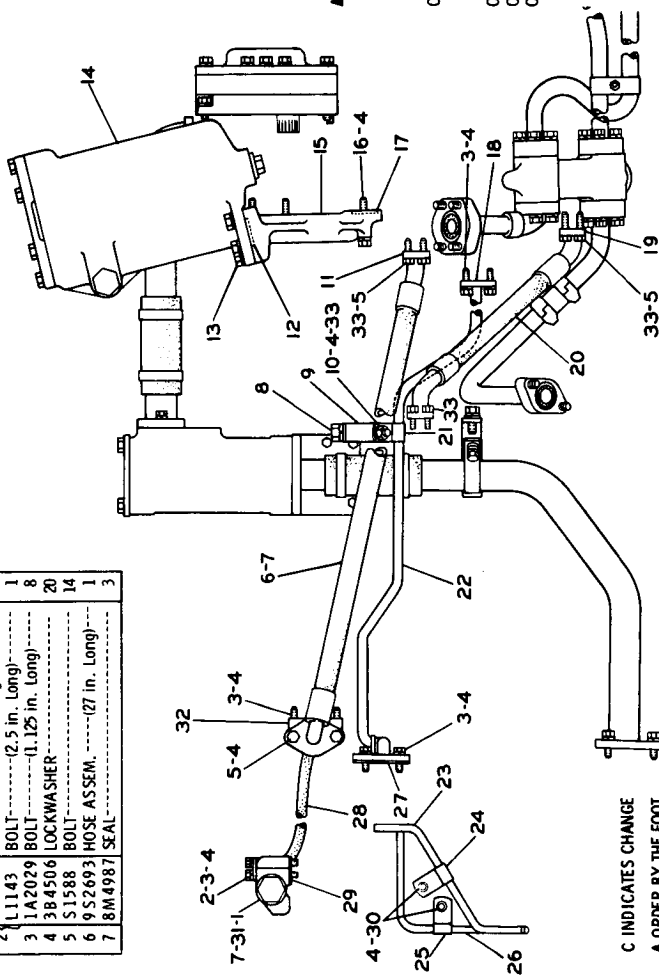

C INDICATES CHANGE  
 ▲ ORDER BY THE FOOT

1	S1624	BOLT	1
2	3B4510	LOCKWASHER	1
3	4B4281	WASHER (BRACKET)	1
4	9J35716	BRACKET	1
5	S1594	BOLT	1
6	1D4717	NUT	1
7	1P4577	FLANGE	2
8	8M4986	SEAL	2
9	S1585	BOLT	5
10	3B4508	LOCKWASHER	5
11	8S666	FILTER GROUP (Separate Illustration)	1
12	3S9845	SUPPORT	1
13	1L2070	BOLT (2.25 in. Long)	4
14	3B1915	BOLT (1.375 in. Long)	4
15	8M5254	SEAL	1
16	9M9037	FLANGE	2
17	1L54	SEAL	1
18	1P4576	FLANGE	1
19	3S58711	HOSE ASSEM. (15.75 in. Long)	4
20	8M4988	SEAL	1
21	8F2395	CLIP	2
22	3S3737	TUBE ASSEM.	1
23	4S8457	TUBE (Bevel Gear Oiling) 13.13 in.	1
24	781597	CLIP	1
25	8B6127	CLIP	1
26	2P9546	TUBE	1
27	1E3133	GASKET	1
28	3P6154	HOSE ASSEM. (19.49 in. Long)	1
29	8M4448	SEAL	1
30	1T102	BOLT	2
31	3P6119	ELBOW	2
32	3P6118	ELBOW	1
33	4B4278	WASHER	13

144069

TRANSMISSION AND STEERING CLUTCH LUBRICATION SYSTEM (7S7401 N/S)—Part 3 of 3  
 Serial No. 11K5069 to 11K5083 Inclusive  
 1P1899 Valve and 8S666 Filter parts are shown on Pages 78 & 82

TRANSMISSION AND STEERING CLUTCH LUBRICATION SYSTEM (7S7401 N/S)—Part 1 of 3  
 Serial No. 11K5084 to 11K5672 inclusive  
 1P3676 Valve parts are shown on Page 79

REF. NO.	PART NUMBER	DESCRIPTION	QTY
1	8M4986	SEAL	1
2	3H5368	BOLT	4
3	3B4507	LOCKWASHER	4
3	1P7585	TUBE ASSEM.	1
4	1P3303	TUBE ASSEM. (Relief Valve to Ref. No. 21)	1
5	2S7070	JOINT ASSEM.	3
	9S2082	SEAL ASSEM.	2
6	7S7281	CLAMP	2
7	L1351	BOLT	3
8	3B4506	LOCKWASHER	30
9	1P3294	TUBE ASSEM.	1
10	8M4987	SEAL	7

11	3B1915	BOLT	12
12	1P3290	TUBE ASSEM.	1
13	7S3916	CLIP	1
14	7S3919	CLIP	1

15	1P3633	TUBE ASSEM.	1
	9S4191	PLUG	1
16	3J1907	SEAL	1
	4B4278	WASHER	3
17	1P3306	TUBE ASSEM.	1
18	2F6578	CLAMP	2
19	S1616	BOLT	1
20	1B4330	NUT	1
	3B4504	LOCKWASHER	1
21	1P3676	VALVE GROUP	1
		(Separate Illustration)	
22	2A4639	BOLT	12
23	1P7587	TUBE ASSEM.	1
24	1P7589	TUBE ASSEM.	2
25	S1571	BOLT	2
26	1D4717	NUT	4

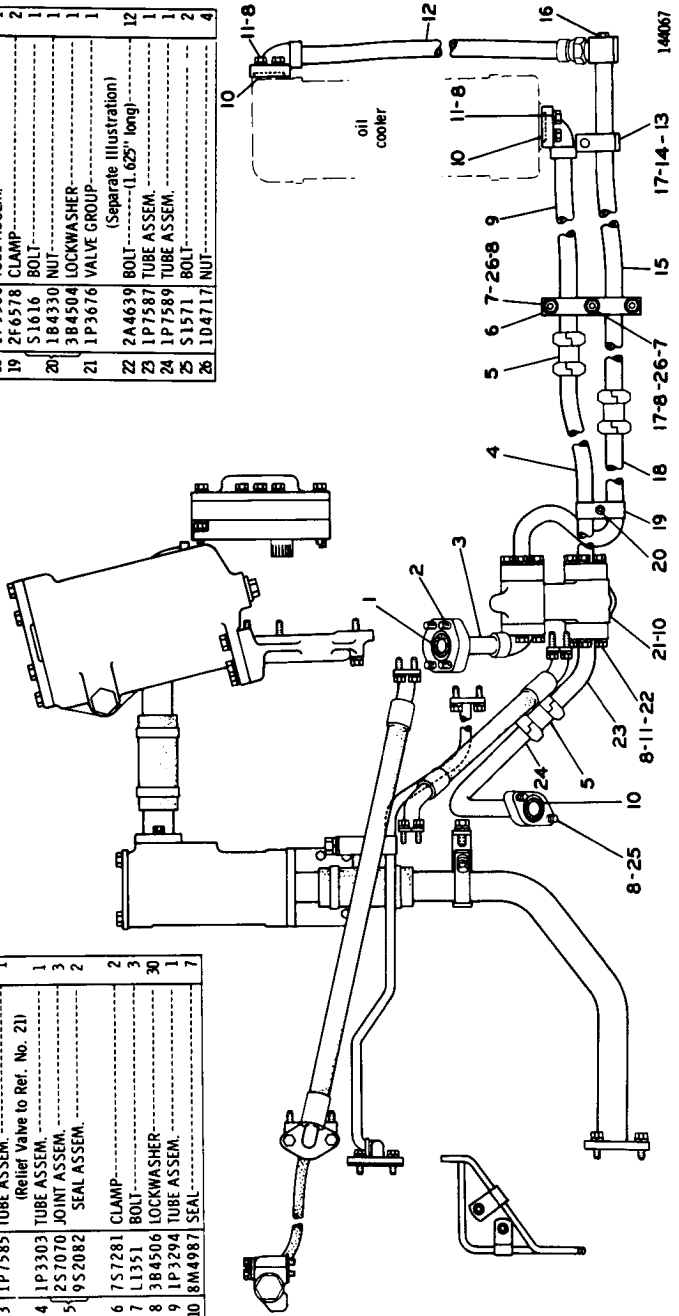

REF. NO.	PART NUMBER	DESCRIPTION	QTY
1	9M8669	SCREEN GROUP (Separate Illustration)	1
2	1A2029	BOLT	7
3	3B4506	LOCKWASHER	14
4	3S3703	TUBE ASSEM.	1
5	1P6261	CLAMP	4
6	1S4018	HOSE	2
7	3S3740	TUBE ASSEM.	1

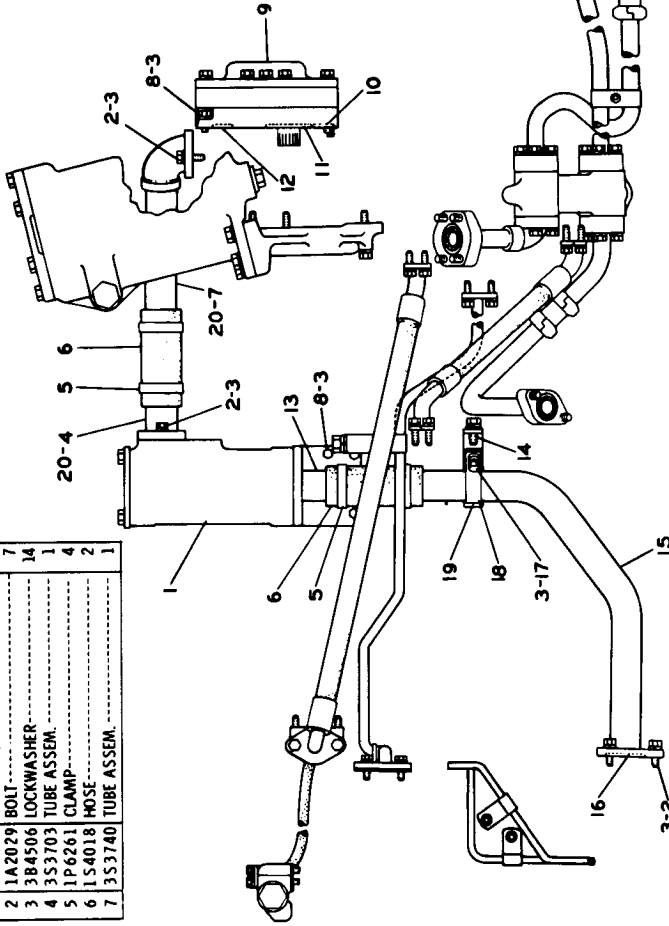

8	51588	BOLT	5
9	1S6520	PUMP GROUP (Separate Illustration)	1
10	8M5007	SEAL	1
11	8M4992	SEAL	1
12	8M4987	SEAL	1
13	3S3708	TUBE ASSEM.	1
14	6H1717	BOLT	1
14	3B4508	LOCKWASHER	1
15	4B4280	WASHER	1
15	3S3698	TUBE ASSEM.	1
16	8M4390	SEAL	1
17	51594	BOLT	2
17	1D4777	NUT	2
18	2H8930	CLAMP	1
19	3S3676	BRACKET	1
20	8M4436	SEAL	2

144070

TRANSMISSION AND STEERING CLUTCH LUBRICATION SYSTEM (7S7401 N/S)—Part 2 of 3

Serial No. 11K5084 to 11K5672 inclusive

9M8669 Screen and 1S6520 Pump parts are shown on Pages 65 and 79

TRANSMISSION AND STEERING CLUTCH LUBRICATION SYSTEM (757401 N/S)—Part 3 of 3  
 Serial No. 11K5084 to 11K5672 inclusive  
 2S8373 Valve and 8S666 Filter parts are shown on Pages 78 and 82

QTY	PART NO.	DESCRIPTION
1	2S8373	VALVE GROUP
1	8M4445	SEAL (Separate illustration)
1	5B9603	BOLT---(5 in. Long)
1	11143	BOLT---(2.5 in. Long)
8	1A2029	BOLT---(1.125 in. Long)
20	3B4506	LOCKWASHER
14	51588	BOLT
1	9S2693	HOSE ASSEM.---(27 in. Long)
1	8M4987	SEAL

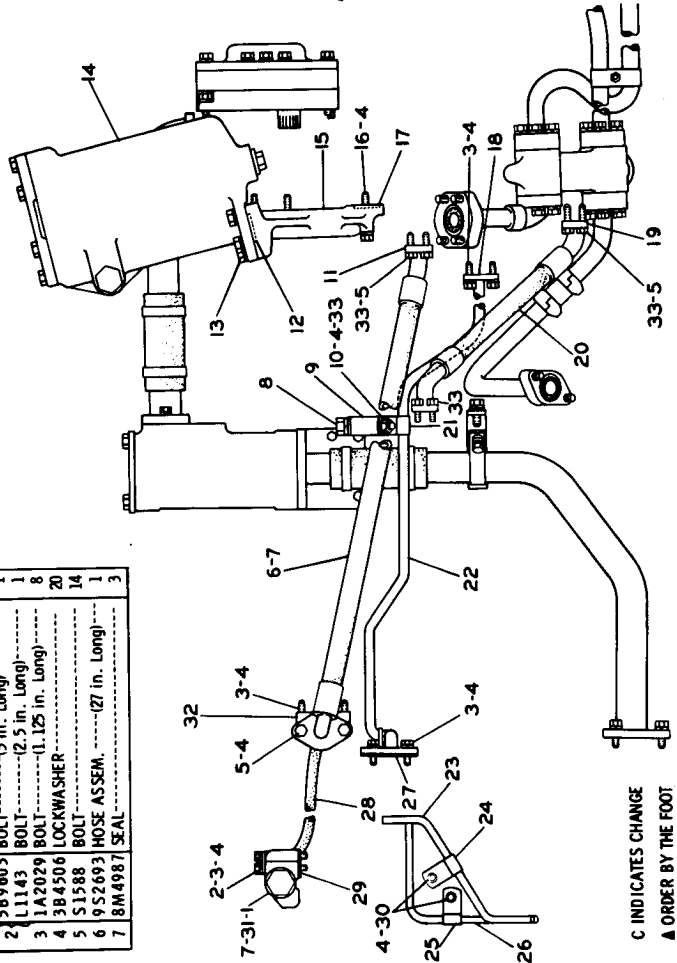

C INDICATES CHANGE  
 ▲ ORDER BY THE FOOT

1	51624	BOLT	1
1	83B4510	LOCKWASHER	1
1	4B4281	WASHER	1
1	3S5716	BRACKET	1
1	51594	BOLT	1
1	11D4717	NUT	1
2	1P4577	FLANGE	2
2	8M4986	SEAL	2
5	51585	BOLT	5
5	3B4508	LOCKWASHER	5
1	8S666	FILTER GROUP (Separate illustration)	1
1	3S9845	SUPPORT	1
4	L2070	BOLT---(2.25 in. Long)	4
4	3B1915	BOLT---(1.375 in. Long)	4
2	8M5254	SEAL	2
1	9M9037	FLANGE	1
1	11S4	SEAL	1
4	1P4576	FLANGE	4
4	3S8711	HOSE ASSEM.---(15.75 in. Long)	4
2	8M4988	SEAL	2
1	8F2395	CLIP	1
1	3S3737	TUBE ASSEM.	1
1	23	4S8457 TUBE---(Bevel Gear Oiling)13.13 in.	1
1	24	7B1597 CLIP	1
1	25	8B6127 CLIP	1
1	26	2P9546 TUBE	1
1	27	1F3133 GASKET	1
1	28	3P6154 HOSE ASSEM.---(19.09 in. Long)	1
1	29	8M4448 SEAL	1
2	30	T102 BOLT	2
1	31	3P6119 ELBOW	1
1	32	3P6118 ELBOW	1
13	4B4278	WASHER	13

144071

REF. NO.	PART NUMBER	DESCRIPTION	QTY
1	8M4986	SEAL.....	1
2	3H5368	BOLT.....	4
3	3B4507	LOCKWASHER.....	4
4	1P7585	TUBE ASSEM. (Relief Valve to Ref. No. 21)	1
5	1P3303	TUBE ASSEM. 257070 JOINT ASSEM. 952082 SEAL ASSEM.	3 3 2
6	75281	CLAMP.....	2
7	L1351	BOLT.....	3
8	3B4506	LOCKWASHER.....	30
9	1P3294	TUBE ASSEM.	1
10	8M4987	SEAL.....	7

11	3B1915	BOLT.....(1.375" long)	12
12	1P3290	TUBE ASSEM.	1
13	753916	CLIP.....(Tab)	1
14	753919	CLIP.....	1

15	1P3633	TUBE ASSEM.	1
16	954191	PLUG.....	1
17	3J1907	SEAL.....	1
18	484278	WASHER.....	3
19	1P3306	TUBE ASSEM.	1
20	2F6578	CLAMP.....	2
21	S1616	BOLT.....	1
22	1B4330	NUT.....	1
23	384504	LOCKWASHER.....	1
24	1P3676	VALVE GROUP. (Separate Illustration)	1
25	2A4639	BOLT.....(1.625" long)	12
26	1P7587	TUBE ASSEM.	1
27	1P7589	TUBE ASSEM.	1
28	S1571	BOLT.....	2
29	1D4717	NUT.....	4

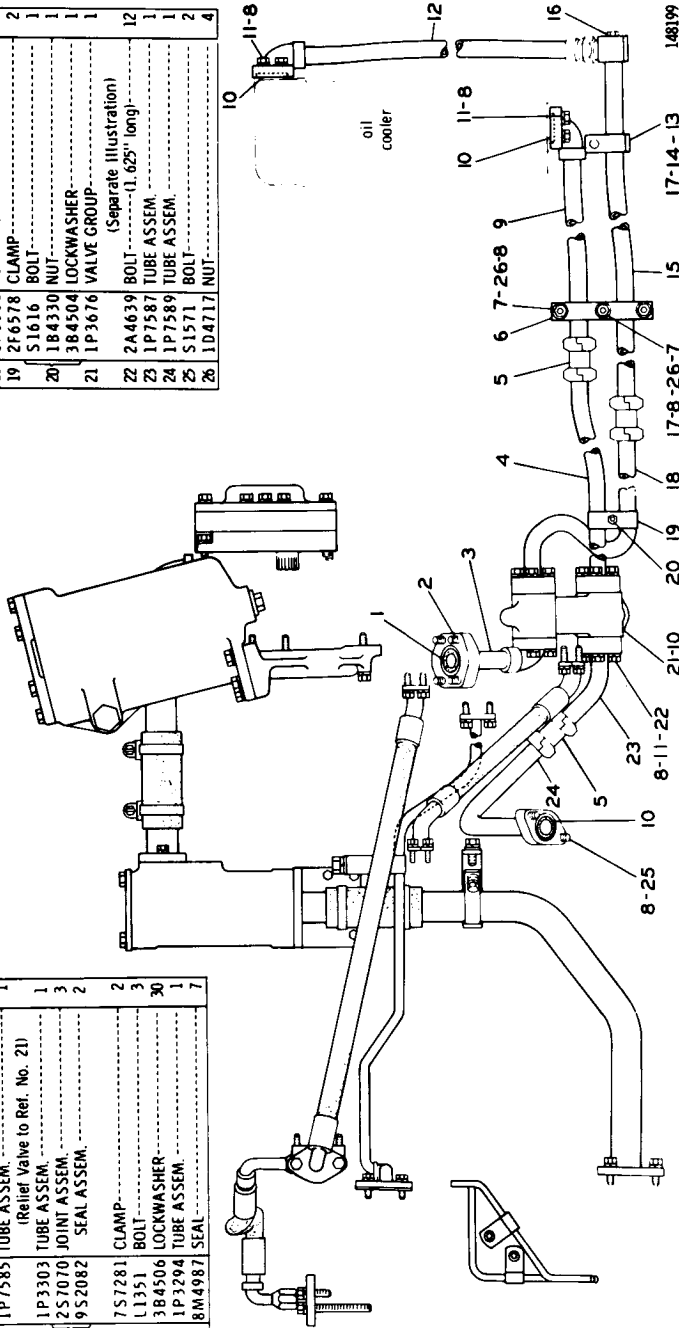

TRANSMISSION AND STEERING CLUTCH LUBRICATION SYSTEM (757401 N/S)—Part 1 of 3

Serial No. 11K5673 to 11K6783 inclusive  
1P3676 Valve parts are shown on Page 79



TRANSMISSION AND STEERING CLUTCH LUBRICATION SYSTEM (7S7401 N/S)—Part 2 of 3

Serial No. 11K5673 to 11K6783 inclusive

9M8669 Screen and 1S6520 Pump parts are shown on Pages 65 and 79

REF. NO.	PART NUMBER	DESCRIPTION	QTY
1	9M8669	SCREEN GROUP (Separate Illustration)	1
2	1A2029	BOLT	7
3	3B4506	LOCKWASHER	14
4	3S3703	TUBE ASSEM.	1
5	5P597	CLAMP	4
6	1S4018	HOSE	2
7	3S3740	TUBE ASSEM.	1

8	51588	BOLT	5
9	1S6520	PUMP GROUP (Separate Illustration)	1
10	8M5007	SEAL	1
11	8M4992	SEAL	1
12	8M4987	SEAL	1
13	3S3708	TUBE ASSEM.	1
14	6H1717	BOLT	1
14	3B4508	LOCKWASHER	1
15	3S3698	TUBE ASSEM.	1
16	8M4390	SEAL	1
17	51594	BOLT	2
17	1D4717	NUT	2
18	2H8930	CLAMP	1
19	3S3676	BRACKET	1
20	8M4436	SEAL	2

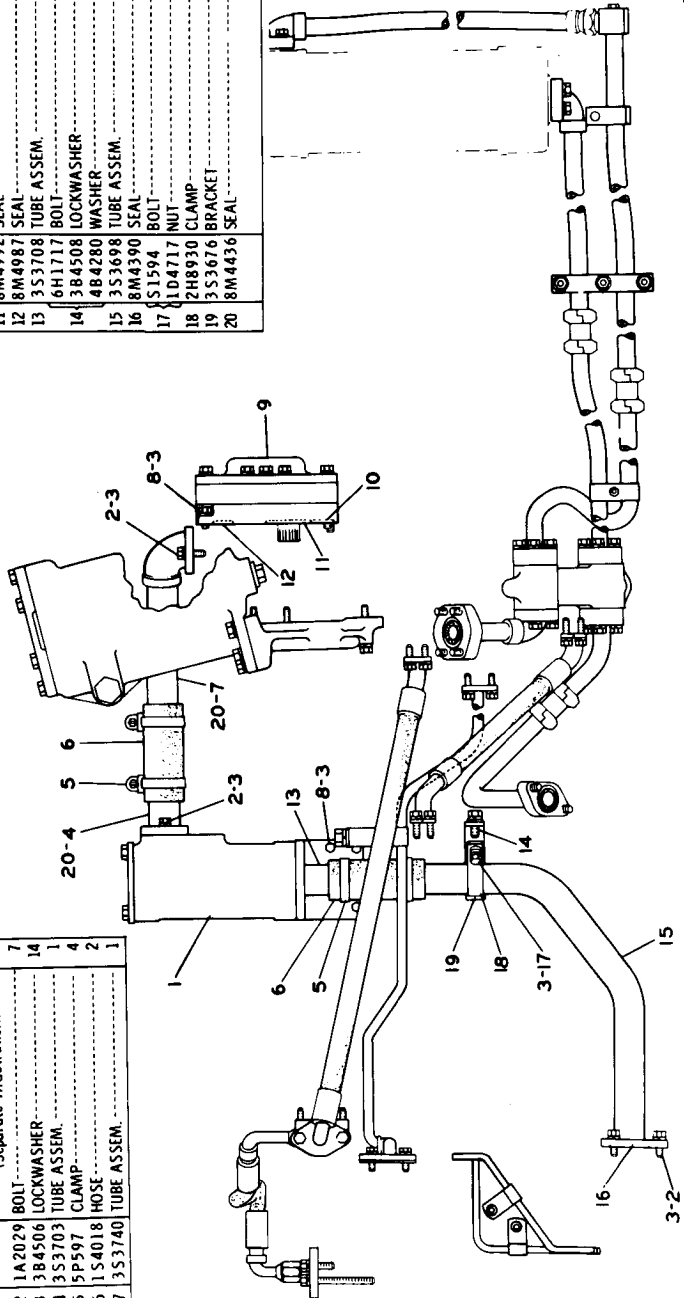

REF NO	PART NUMBER	DESCRIPTION	QTY
C	3P6278	HOSE ASSEM. ---(12.50 in. long)---	1
C	17L7262	FITTING	1
C	2 5S7382	BOLT	6
C	3 1A2029	BOLT	6
C	4 3B4506	LOCKWASHER	18
C	5 5L588	BOLT	14
C	6 9S2693	HOSE ASSEM. ---(27 in. long)---	1
C	7 8M4987	SEAL	3

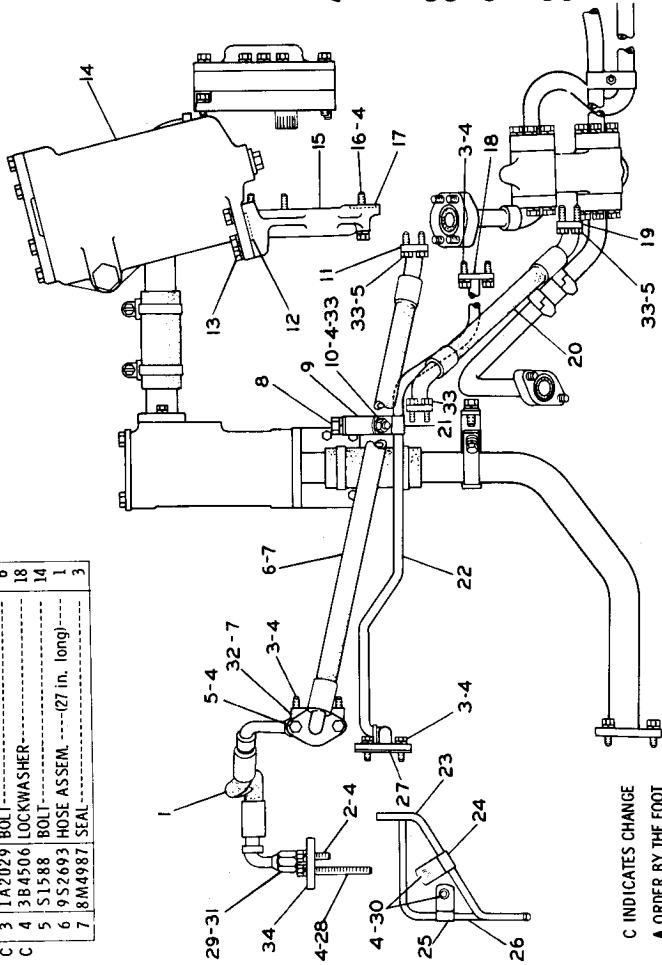

1	51624	BOLT	
8	3B4510	LOCKWASHER	
1	4B4281	WASHER	
9	3S5716	BRACKET	
1	5S1594	BOLT	
10	11D4717	NUT	
2	1P4571	FLANGE	
2	8M4986	SEAL	
13	5S1585	BOLT	
5	3B4508	LOCKWASHER	
1	8S666	FILTER GROUP	
		(Separate Illustration)	
15	3S9845	SUPPORT	
16	L2070	BOLT	---(2.25 in. Long)
4	3B1915	BOLT	---(1.375 in. Long)
2	8M5254	SEAL	
17	9M9037	FLANGE	
18	1SA	SEAL	
19	1P4576	FLANGE	
4	3S5871	HOSE ASSEM.	---(15.75 in. Long)
20	8M4988	SEAL	
2	8F2395	CLIP	
1	3S3737	TUBE ASSEM.	
1	4S6457	TUBE	---(Bevel Gear Oiling)13.13 in.
1	7B1597	CLIP	
1	8B6127	CLIP	
1	2P9546	TUBE	
1	1F3133	GASKET	
1	2H9889	BOLT	
1	29	3K360	SEAL
1	30	T102	BOLT
2	31	8M505	FITTING
1	32	3P6118	ELBOW
13	33	4B4278	WASHER
1	34	3P6258	FLANGE
1	34	5H7153	SEAL

C INDICATES CHANGE

▲ ORDER BY THE FOOT

TRANSMISSION AND STEERING CLUTCH LUBRICATION SYSTEM (7S7401 N/S)—Part 3 of 3  
 Serial No. 11K5673 to 11K6783 inclusive  
 8S666 Filter parts are shown on Page 82

147266

TRANSMISSION AND STEERING CLUTCH LUBRICATION SYSTEM (757401 N/S)—Part 1 of 3  
 Serial No. 11K6784—Up

1P3676 Valve parts are shown on Page 79

REF. NO.	PART NUMBER	DESCRIPTION	QTY
1	8M4986	SEAL	1
2	3H5368	BOLT	4
3	3B4507	LOCKWASHER	4
4	1P7585	TUBE ASSEM. (Relief Valve to Ref. No. 21)	1
5	2S7070	JOINT ASSEM.	1
6	9S2082	SEAL ASSEM.	2
7	7S7281	CLAMP	2
8	1L1351	BOLT	3
9	3B4506	LOCKWASHER	30
10	1P3294	TUBE ASSEM.	1
	8M4987	SEAL	1

11	3B1915	BOLT	1.375 in. (3.4 cm) long	12
12	1P3290	TUBE ASSEM.		1
13	7S3916	CLIP	(Tab)	1
14	7S3919	CLIP		1

15	1P3633	TUBE ASSEM.	1	
	9S4191	PLUG	1	
16	3J1907	SEAL	1	
17	4B4278	WASHER	3	
18	1P3306	TUBE ASSEM.	2	
19	2F6578	CLAMP	2	
	5L1616	BOLT	1	
20	1B4330	NUT	1	
	3B4504	LOCKWASHER	1	
21	1P3676	VALVE GROUP (Separate Illustration)	1	
22	2A4639	BOLT	1.625 in. (4.1 cm) long	12
23	1P7587	TUBE ASSEM.	1	
24	1P7589	TUBE ASSEM.	1	
25	5L1571	BOLT	2	
26	1D4717	NUT	4	

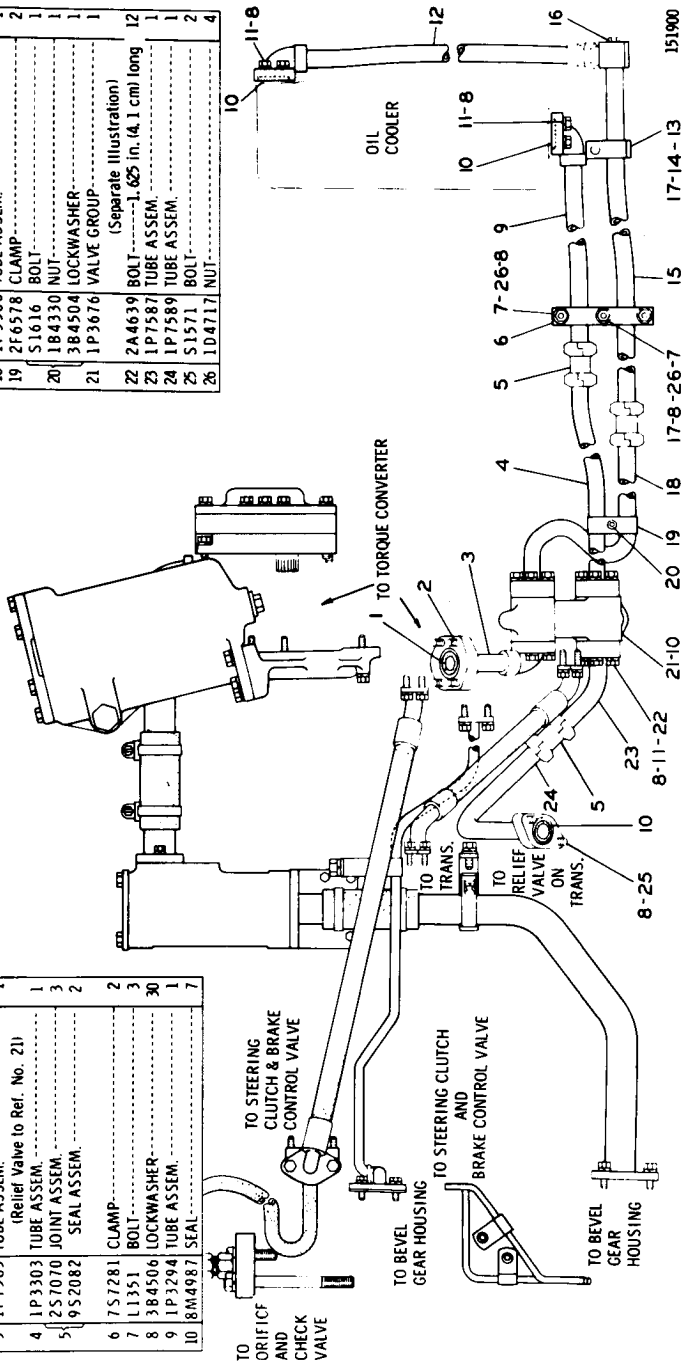

REF. NO.	PART NUMBER	DESCRIPTION	QTY
1	9M8669	SCREEN GROUP.....	1
2	1A2029	BOLT.....	7
3	3B4506	LOCKWASHER.....	14
4	3S3703	TUBE ASSEM.....	1
5	5P597	CLAMP.....	4
6	1S4018	HOSE.....	2
7	3S3740	TUBE ASSEM.....	1

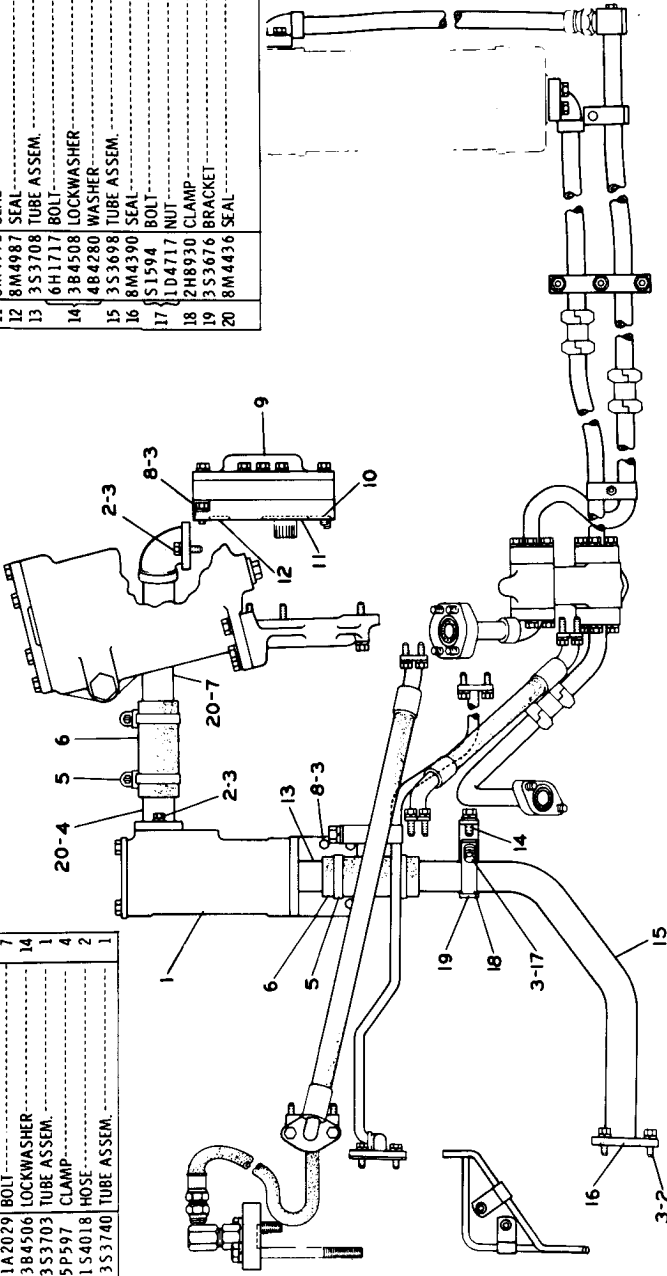

8	S1588	BOLT.....	5
9	1S6520	PUMP GROUP.....	1
		(Separate Illustration)	
10	8M5007	SEAL.....	1
11	8M4992	SEAL.....	1
12	8M4987	SEAL.....	1
13	3S3708	TUBE ASSEM.....	1
14	6H1717	BOLT.....	1
14	3B4508	LOCKWASHER.....	1
15	3S3698	TUBE ASSEM.....	1
16	8M4390	SEAL.....	1
17	S1594	BOLT.....	2
17	1D4717	NUT.....	2
18	2H8930	CLAMP.....	1
19	3S3676	BRACKET.....	1
20	8M4436	SEAL.....	2

151901

TRANSMISSION AND STEERING CLUTCH LUBRICATION SYSTEM (7S7401 N/S)—Part 2 of 3

Serial No. 11K6784—Up

9M8669 Screen and 1S6520 Pump parts are shown on Pages 65 and 79

TRANSMISSION AND STEERING CLUTCH LUBRICATION SYSTEM (7S7401 N/S)—Part 3 of 3

Serial No. 11K6784—Up

8S666 Filter parts are shown on Page 82

REF NO	PART NUMBER	DESCRIPTION	QTY
C 1	3P6154	HOSE ASSEM. ....19.49 in. (50 cm)	1
2	5S7382	BOLT	1
3	1A2029	BOLT	6
4	3B4506	LOCKWASHER	18
5	5L588	BOLT	14
6	9S2693	HOSE ASSEM. ....27 in. (68.5 dm)	3
7	8M4987	SEAL	3

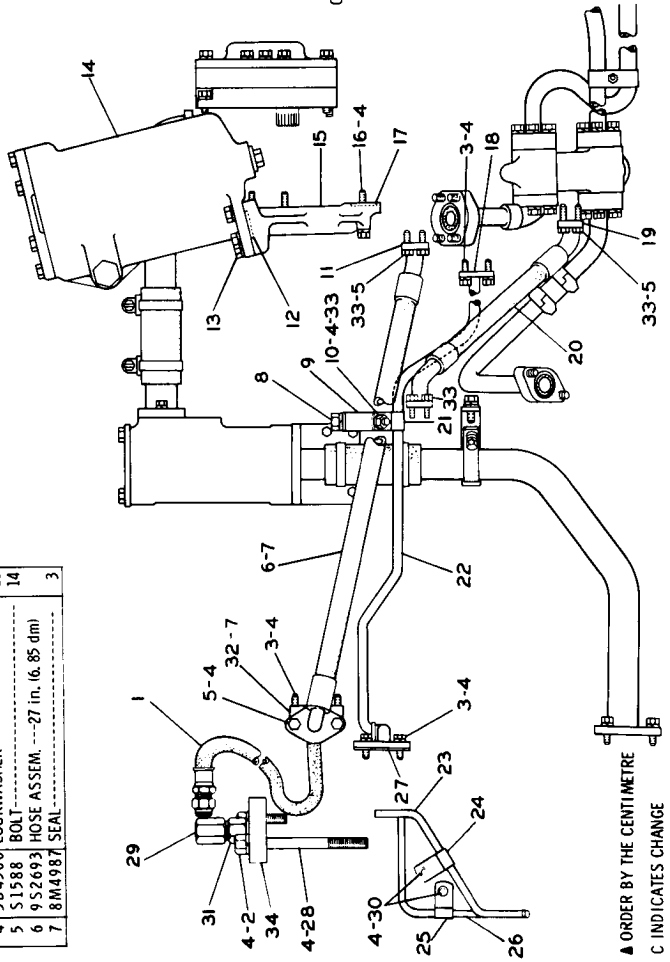

▲ ORDER BY THE CENTIMETRE

C INDICATES CHANGE

5	5L624	BOLT	1
8	3B4510	LOCKWASHER	1
9	4B4281	WASHER	1
9	3S5716	BRACKET	1
10	5L594	BOLT	1
10	1D4717	NUT	1
11	1P4577	FLANGE	2
12	8M4986	SEAL	2
13	5L585	BOLT	5
13	3B4508	LOCKWASHER	5
14	8S666	FILTER GROUP	1
15	3S9845	SUPPORT	1
16	1D2070	BOLT	4
16	3B1915	BOLT	1
17	8M5254	SEAL	2
18	9M9037	FLANGE	1
18	1L54	SEAL	4
19	1P4576	FLANGE	4
20	3S8711	HOSE ASSEM.	1
20	8M4988	SEAL	2
21	8F2395	CLIP	1
22	3S3737	TUBE ASSEM.	1
23	5P1200	TUBE	1
C▲	23	5P1200	1
24	7B1597	CLIP	1
25	8B6127	CLIP	1
26	2P9546	TUBE	1
27	1F3133	GASKET	1
28	2H9889	BOLT	1
29	4D577	UNION	1
C	29	4D577	1
30	T102	BOLT	2
C	31	619413	CONNECTOR
32	3P6118	ELBOW	1
33	4B4278	WASHER	13
34	3P6258	FLANGE	1
34	5H7153	SEAL	1

C INDICATES CHANGE

151305

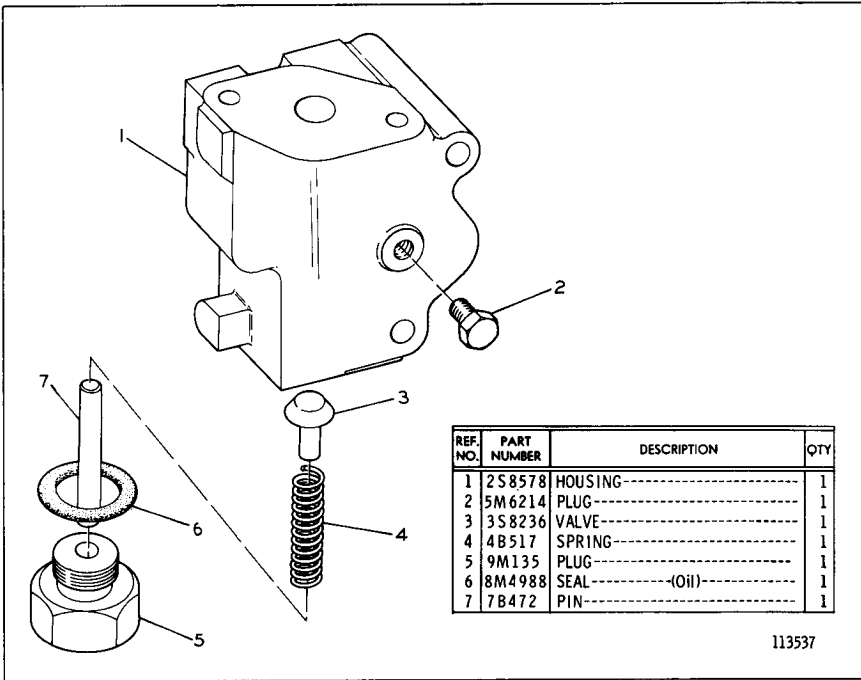
**1P1899 CHECK VALVE GROUP**

Serial No. 11K5051 to 11K5083 inclusive. Part of Transmission and Steering Clutch Lubrication System shown on Pages 68, 71 and 74

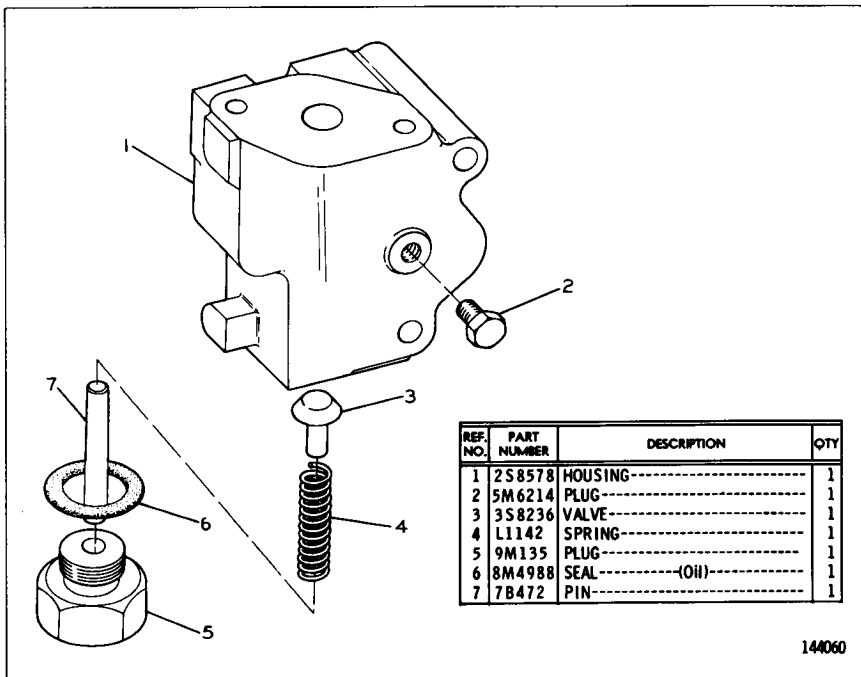
**2S8373 CHECK VALVE GROUP**

Serial No. 11K5084 to 11K5672 inclusive. Part of Transmission and Steering Clutch Lubrication System shown on Page 77

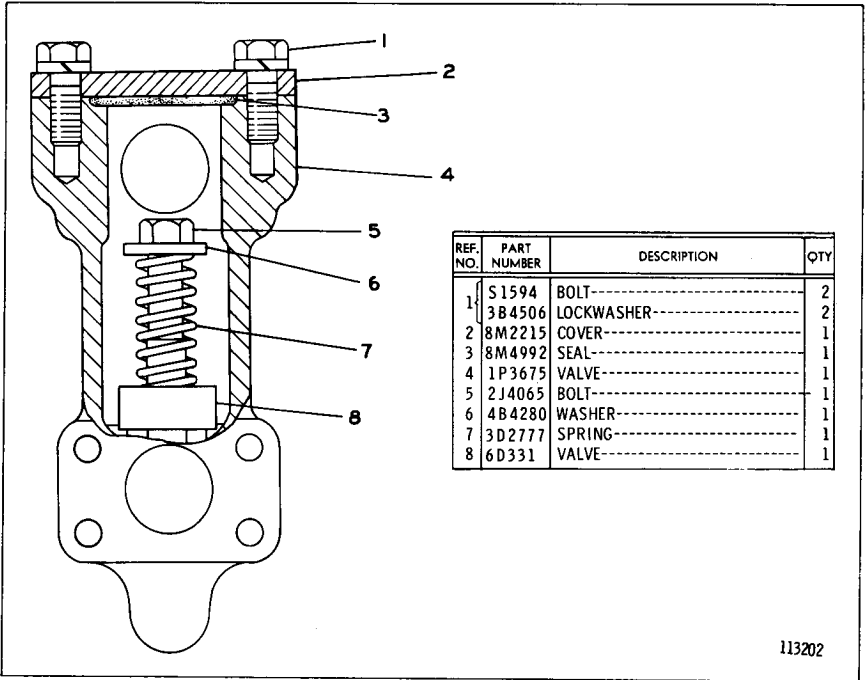

**1P3676 BY-PASS VALVE GROUP**  
 Part of Transmission and Steering Clutch Lubrication  
 System shown on Pages 66, 69, 72 & 75

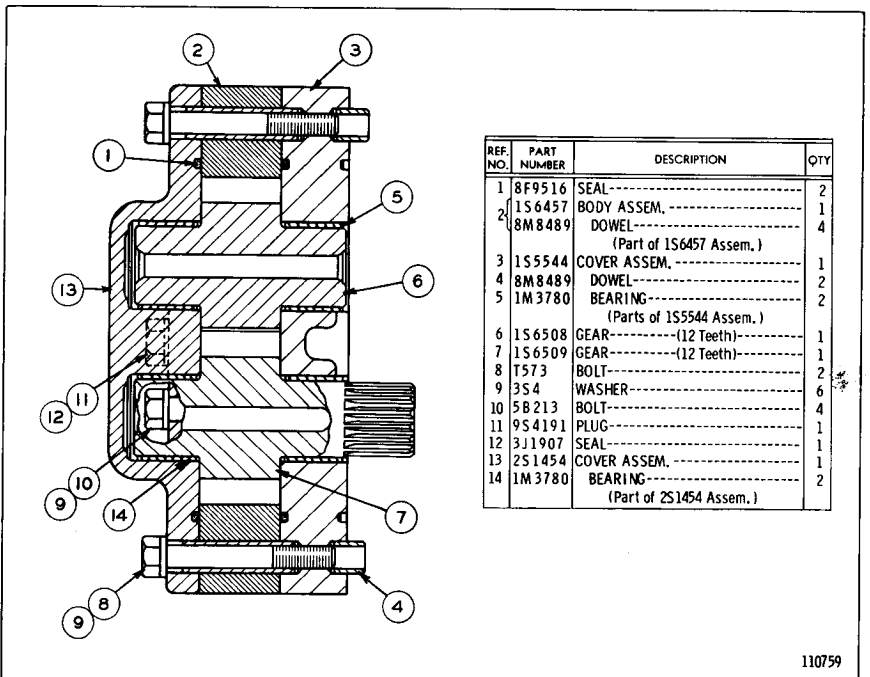

**1S6520 OIL PUMP GROUP**  
 Part of Transmission & Steering Clutch Lubrication  
 System shown on Pages 67, 70, 73 & 76

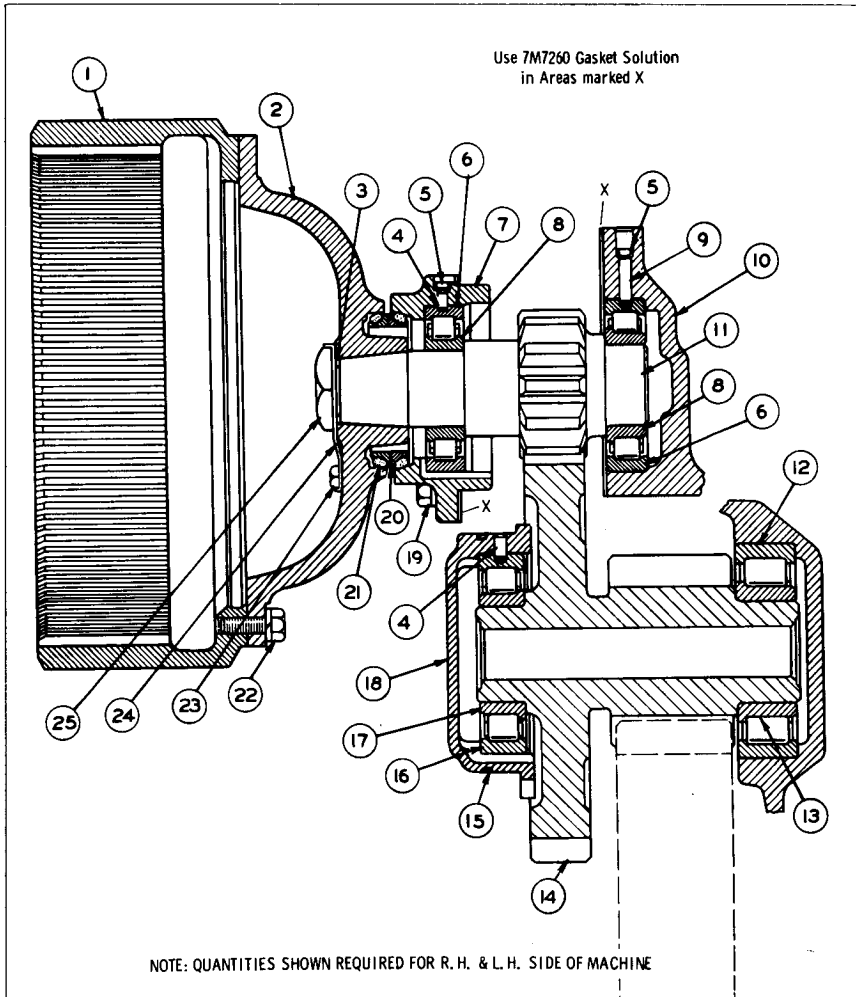

NOTE: QUANTITIES SHOWN REQUIRED FOR R. H. & L. H. SIDE OF MACHINE

REF. NO.	PART NUMBER	DESCRIPTION	QTY
1	2S7603	DRUM-----	2
2	2S7607	FLANGE-----	2
3	5M6711	GASKET-----	2
4	3F1953	DOWEL-----	6
5	L1026	PLUG-----	6
6	6B5163	RACE AND ROLLER ASSEM.-----	4
7	7S847	CAGE-----	2
8	2P2810	RACE-----	4
9	3H4174	DOWEL-----	2
10	3S2485	CASE----- (Right Hand)	1
	3S2486	CASE----- (Left Hand)	1
	2B7557	CORK-----	6
	1A5919	DOWEL-----	6
11	5S192	PINION----- (12 Teeth)	2
12	5M7705	RACE AND ROLLER ASSEM.-----	2

13	9S4085	RACE-----	2
14	1P1898	GEAR AND PINION-(38 & 10 Teeth)-	2
15	1S4974	SEAL-----	2
16	6B5067	RACE AND ROLLER ASSEM.-----	2
17	9S8669	RACE-----	2
18	5M7383	CAGE-----	2
19	S1585	BOLT-----	12
	3H7654	WASHER-----	12
C 20	2P3395	SEAL GROUP-----	2
	2P3394	SEAL----- (Rubber)	2
22	S1589	BOLT-----	24
	3B4510	LOCKWASHER-----	24
23	1K6705	BOLT-----	2
24	5M6704	LOCK-----	2
25	L2341	NUT-----	2
	FE055108	FORM---(Seal Group Installation)	1

C INDICATES CHANGE

119148

FINAL DRIVE (3S2038 N/S)—Upper Half—Type 1  
Serial No. 11K5051 to 11K5958 inclusive



NOTE: QUANTITIES SHOWN REQUIRED FOR R. H. & L. H. SIDE OF MACHINE

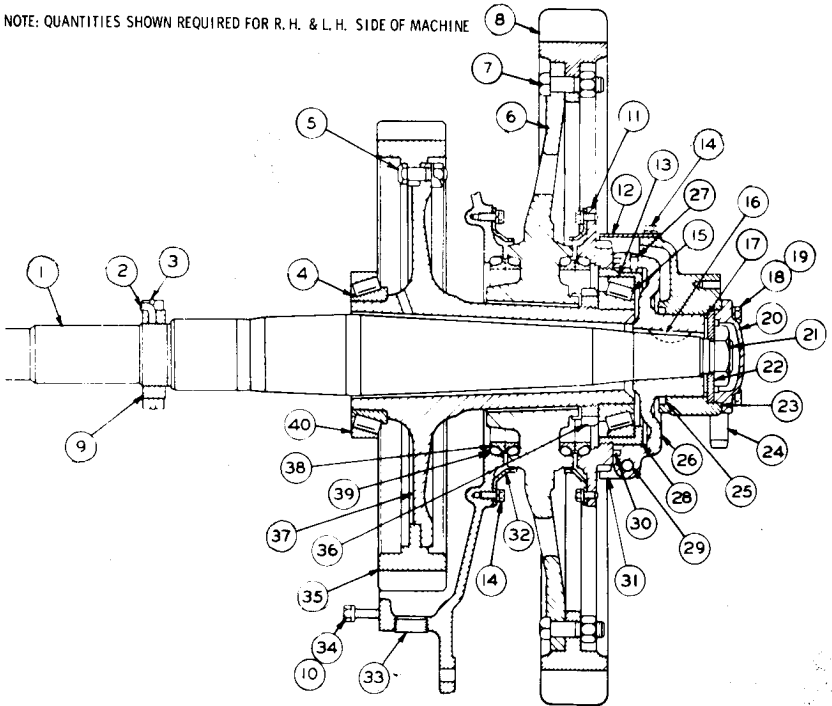

REF. NO.	PART NUMBER	DESCRIPTION	QTY
1	5M6670	SHAFT	2
2	2B7906	PIN	2
3	2B8091	RING	2
4	9M2744	CONE	2
5	3B4990	BOLT	36
5	2K4821	NUT	36
5	2S8415	WASHER	36
6	1P971	SPROCKET GROUP	2
6	9S9651	HUB	1
7	3S336	BOLT	27
7	7H3608	NUT	27
8	5S58	SEGEMENT GROUP-(9 Segments)	1
9	5M2130	NUT	2
10	2M849	WASHER	64
11	9S4236	NUT	2
12	3S771	GUARD	2
13	6B4370	CUP	2
14	5S09	BOLT	48
14	3B4506	LOCKWASHER	48
15	1L7518	CONE	2
16	1B8742	KEY	2
17	6B4823	SHIM	6
18	7B3235	BOLT	8
19	3B4508	LOCKWASHER	8
20	4S8958	CAP	2
20	4S9065	GASKET	2
21	1A7486	NUT	2
21	6B4809	LOCK	2

22	6B4936	WASHER ASSEM.	2	
	2H1190	DOWEL	1	
23	3S777	BEARING	4	
24	2M122	DOWEL	2	
C 25	2P3394	RING	2	
	9S4235	HOLDER ASSEM.	2	
C 26	4F2954	PIN	2	
	27	L2061	DOWEL	1
28	3S775	CAGE	2	
	6F7024	BOLT	2	
29	1B4206	NUT	2	
C 29	1F4583	SEAL	2	
30	2P1507	GASKET	2	
C 31	3P3623	LOCK	2	
	32	9S2172	GUARD	4
33	5S4017	PLUG	2	
34	S1585	BOLT-(1.50" long)	56	
	1B2886	BOLT-(3.75" long)	8	
35	1P1897	GEAR-(51 Teeth)	2	
	9S9649	NUT	2	
36	9S9648	LOCK	2	
37	9S9650	HUB	2	
38	5M8647	SEAL GROUP	4	
39	1M9011	SEAL-(Rubber)	4	
40	1M6573	CUP	2	
C 41	3B4510	LOCKWASHER	2	

119149

C INDICATES CHANGE

FINAL DRIVE (3S2038 N/S)—Lower Half—Type 1  
Serial No. 11K5051 to 11K5958 inclusive

USE 7M7260 GASKET SOLUTION  
IN AREAS MARKED X

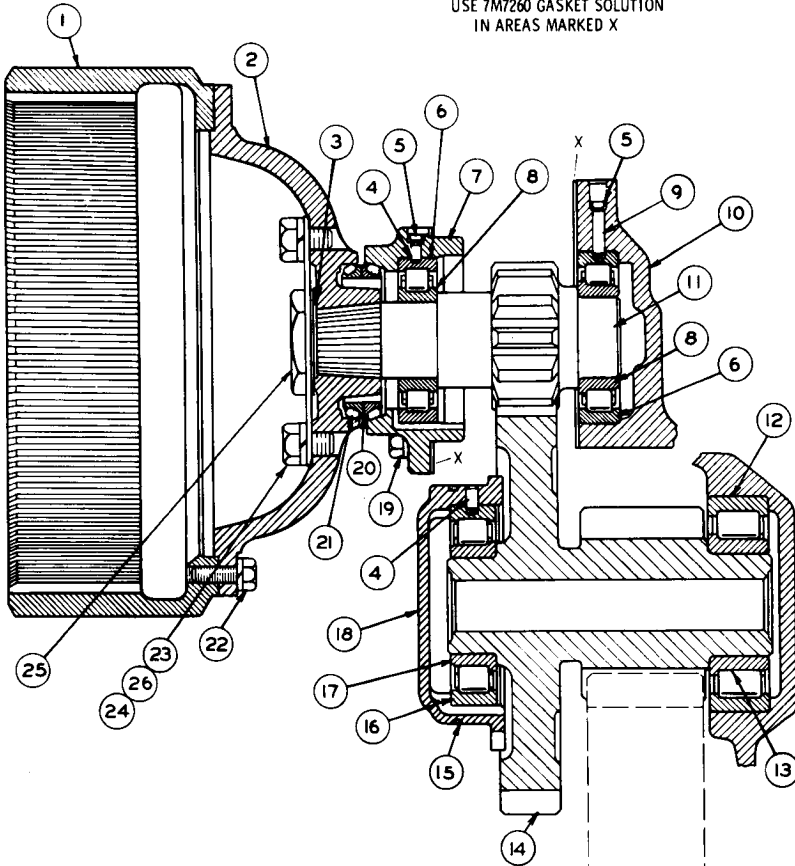

NOTE: QUANTITIES SHOWN REQUIRED FOR R. H. & L. H. SIDE OF MACHINE

REF. NO.	PART NUMBER	DESCRIPTION	QTY
1	2S7603	DRUM-----	2
2	3P6318	FLANGE-----	2
C 3	3P7236	GASKET-----	2
C 4	3F1953	DOWEL-----	6
5	L1026	PLUG-----	6
6	6B5163	RACE AND ROLLER ASSEM.-----	4
7	7S847	CAGE-----	2
8	2P2810	RACE-----	4
9	3H4174	DOWEL-----	2
	3S2485	CASE----- (Right Hand)	1
	3S2486	CASE----- (Left Hand)	1
10	2B7557	CORK-----	6
	1A5919	DOWEL-----	6
11	5S192	PINION----- (12 Teeth)	2
12	5M7705	RACE AND ROLLER ASSEM.-----	2

13	9S4085	RACE-----	2
14	1P1898	GEAR AND PINION-(38 & 10 Teeth)-	2
15	1S4974	SEAL-----	2
16	6B5067	RACE AND ROLLER ASSEM.-----	2
17	9S8669	RACE-----	2
18	5M7383	CAGE-----	2
	S1585	BOLT-----	12
19	3H7654	WASHER-----	12
20	2P3395	SEAL GROUP-----	2
21	2P3394	SEAL----- (Rubber)	2
	S1589	BOLT-----	24
22	3B4510	LOCKWASHER-----	24
C 23	7H2069	BOLT-----	4
C 24	3P6317	LOCK-----	2
C 25	2J5815	NUT-----	2
C 26	3B4512	LOCKWASHER-----	4
	FE055108	FORM--(Seal Group Installation)--	1

C INDICATES CHANGE

202106

FINAL DRIVE (3S2038 N/S)—Upper Half—Type 2  
Serial No. 11K5051 to 11K5958 inclusive

POWER TRAIN-POWER TRANSMISSION UNIT 80C

NOTE: QUANTITIES SHOWN REQUIRED FOR R. H. & L. H. SIDE OF MACHINE

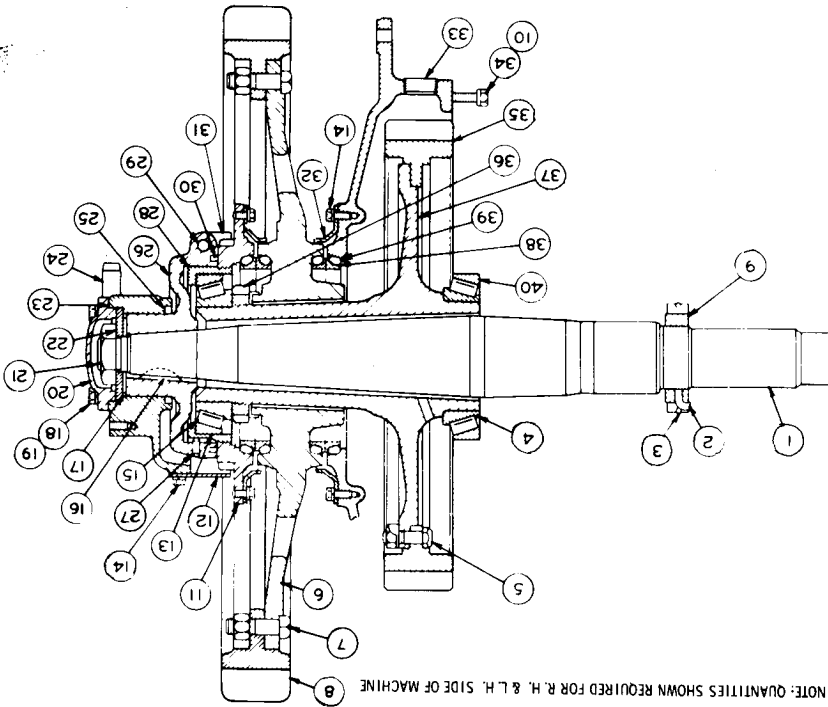

REF. NO.	PART NUMBER	DESCRIPTION	QTY
1	5M 670	SHAFT	2
2	2B 706	PIN	2
3	2B 801	RING	2
4	9M 2744	CONN.	2
5	3B 4990	BOLT	36
6	2K 4821	NUT	36
7	3S 336	BOLT	27
7	7H 308	NUT	27
8	5S 58	SEGMENT GROUP-(9 Segments)-	1
9	2M 2130	NUT	2
10	2M 849	WASHER	64
11	9S 4236	NUT	2
12	3S 771	GUARD	2
13	6B 4370	CUP	2
14	5S 09	BOLT	48
14	3B 4506	LOCKWASHER	48
15	1L 7518	CONN.	2
16	1B 742	KEY	2
17	6B 4823	SHIM	6
18	7B 3235	BOLT	8
19	3B 4508	LOCKWASHER	8
20	4S 905	GASKET	2
21	1A 7486	NUT	2
21	6B 4809	LOCK	2

22	8B 4936	WASHER ASSEM.	2
22	2H 190	DOWEL	1
23	3S 777	BEARING	2
24	2M 122	DOWEL	4
25	2P 3394	RING	2
26	9S 4235	HOLDER ASSEM.	2
27	4F 2954	PIN	2
27	L 2061	DOWEL	1
28	3S 775	CAGE	2
29	6F 7024	BOLT	2
29	1B 4206	NUT	2
30	2P 1507	GASKET	2
31	3P 2623	LOCK	2
32	9S 2172	GUARD	2
33	5S 4017	PLUG	2
34	1S 185	BOLT	2
34	1B 2886	BOLT	2
35	1P 1897	GEAR	2
36	9S 9649	NUT	2
36	9S 9648	LOCK	2
37	9S 9650	HUB	2
38	5M 8647	SEAL GROUP	2
39	1M 9011	SEAL	4
40	1M 6573	CUP	2
41	3B 4510	LOCKWASHER	2

C INDICATES CHANGE

119149

FINAL DRIVE (3S2038 N/S)-Lower Half-Type 2  
Serial No. 11K5051 to 11K5958 inclusive

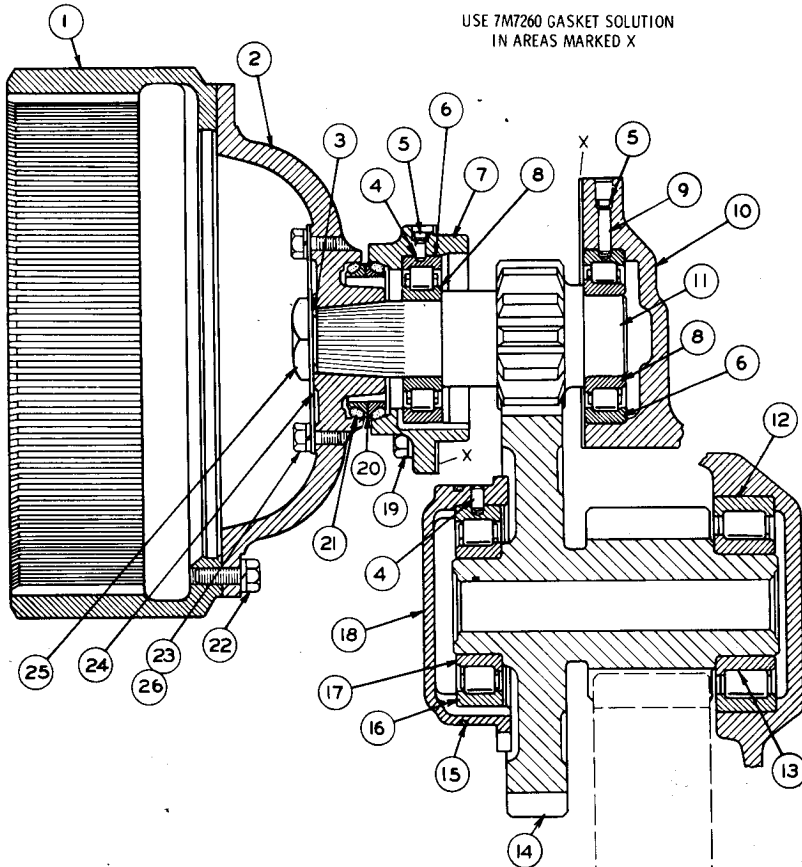

NOTE: QUANTITIES SHOWN REQUIRED FOR R. H. & L. H. SIDE OF MACHINE

REF. NO.	PART NUMBER	DESCRIPTION	QTY
1	2S7603	DRUM-----	2
2	3P6318	FLANGE-----	2
3	3P7236	GASKET-----	2
4	3F1953	DOWEL-----	6
5	L1026	PLUG-----	6
6	6B5163	RACE AND ROLLER ASSEM.-----	4
7	7S847	CAGE-----	2
8	2P2810	RACE-----	4
9	3H4174	DOWEL-----	2
10	3S2485	CASE----- (Right Hand)	1
	3S2486	CASE----- (Left Hand)	1
	2B7557	CORK-----	6
	1A5919	DOWEL-----	6
11	5S192	PINION----- (12 Teeth)	2
12	5M7705	RACE AND ROLLER ASSEM.-----	2

13	9S4085	RACE-----	2
14	1P1898	GEAR AND PINION-(38 & 10 Teeth)-	2
15	1S4974	SEAL-----	2
16	6B5067	RACE AND ROLLER ASSEM.-----	2
17	9S8669	RACE-----	2
18	5M7383	CAGE-----	2
19	S1585	BOLT-----	12
	3H7654	WASHER-----	12
20	2P3395	SEAL GROUP-----	2
21	2P3394	SEAL----- (Rubber)	2
22	S1589	BOLT-----	24
	3B4510	LOCKWASHER-----	24
23	7H2069	BOLT-----	4
24	3P6317	LOCK-----	2
25	2J5815	NUT-----	2
26	3B4512	LOCKWASHER-----	4

201823

FINAL DRIVE (3P1436 N/S)—Upper Half  
Serial No. 11K5959—Up

NOTE: QUANTITIES SHOWN REQUIRED FOR R. H. & L. H. SIDE OF MACHINE

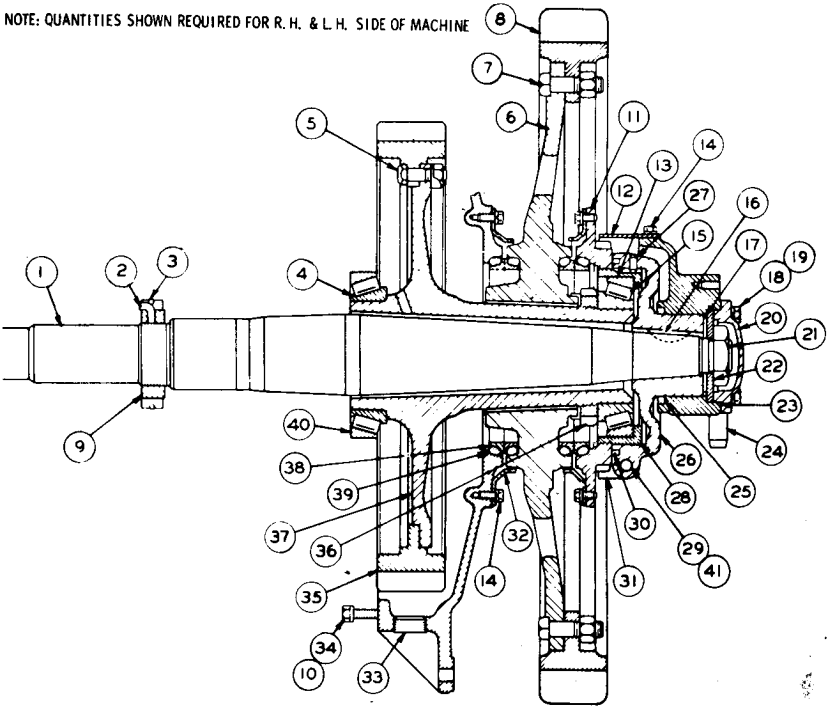

REF. NO.	PART NUMBER	DESCRIPTION	QTY
1	5M6670	SHAFT	2
2	2B7906	PIN	2
3	2B8091	RING	2
4	9M2744	CONE	2
5	3B4990	BOLT	36
5	2K4821	NUT	36
5	2S8415	WASHER	36
6	3P1435	SPROCKET GROUP	2
6	3P1460	HUB	1
7	3S336	BOLT	20
7	7H3608	NUT	20
8	3S351	SEGMENT	5
9	5M2130	NUT	2
10	2M849	WASHER	64
11	9S4236	NUT	2
12	3S771	GUARD	2
13	6B4370	CUP	2
14	5S09	BOLT	48
14	3B4506	LOCKWASHER	48
15	1L7518	CONE	2
16	1B8742	KEY	2
17	6B4823	SHIM	6
18	7B3235	BOLT	8
19	3B4508	LOCKWASHER	8
20	4S8958	CAP	2
20	4S9065	GASKET	2
21	1A7486	NUT	2
21	6B4809	LOCK	2

22	6B4936	WASHER ASSEM.	2
22	2H1190	DOWEL	1
23	3S777	BEARING	2
24	2M122	DOWEL	4
25	2P3394	RING	2
26	9S4235	HOLDER ASSEM.	2
26	4F2954	PIN	2
27	L2061	DOWEL	1
28	3S775	CAGE	2
28	6F7024	BOLT	2
29	1B4206	NUT	2
29	1F4583	SEAL	2
30	2P1507	GASKET	2
31	3P3623	LOCK	2
32	9S2172	GUARD	4
33	5S4017	PLUG	2
34	S158.5	BOLT (1.50" long)	56
34	1B2886	BOLT (3.75" long)	8
35	1P1897	GEAR (51 Teeth)	2
36	9S9649	NUT	2
36	9S9648	LOCK	2
37	9S9650	HUB	2
38	5M8647	SEAL GROUP	4
39	1M9011	SEAL (Rubber)	4
40	1M6573	CUP	2
41	3B4510	LOCKWASHER	2

201824

FINAL DRIVE (3P1436 N/S)—Lower Half  
Serial No. 11K5959—Up

CATERPILLAR 977L TRAXCAVATOR

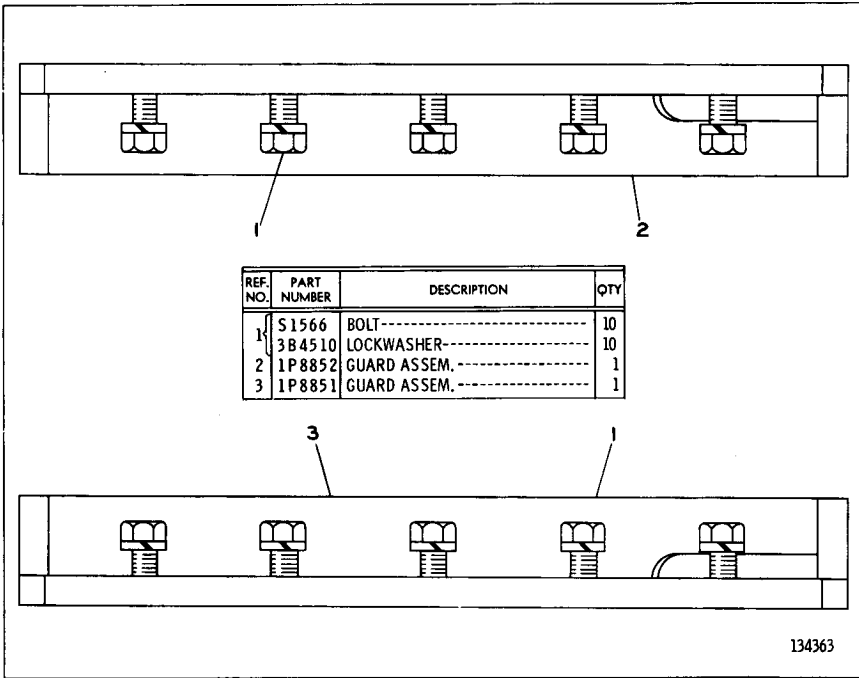

REF. NO.	PART NUMBER	DESCRIPTION	QTY
1	51566	BOLT-----	10
	384510	LOCKWASHER-----	10
2	1P8852	GUARD ASSEM.-----	1
3	1P8851	GUARD ASSEM.-----	1

134363

1P8853 FINAL DRIVE GUARD GROUP  
 Also part of 1P9409 Steel Mill Traxcavator Arrangement  
 listed on Page 104. AN ATTACHMENT

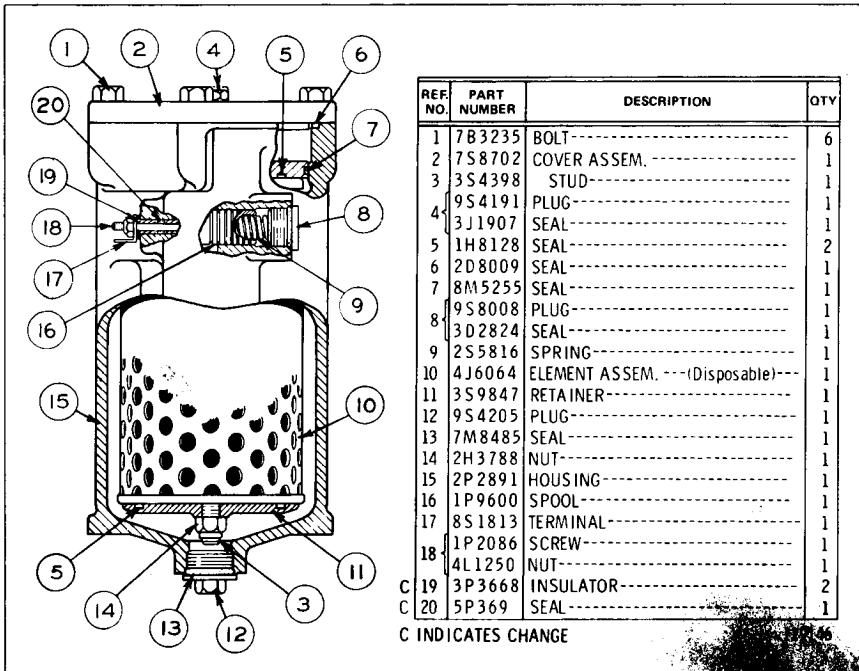

REF. NO.	PART NUMBER	DESCRIPTION	QTY
1	7B3235	BOLT-----	6
2	7S8702	COVER ASSEM.-----	1
3	3S4398	STUD-----	1
4	9S4191	PLUG-----	1
	3J1907	SEAL-----	1
5	1H8128	SEAL-----	2
6	2D8009	SEAL-----	1
7	8M5255	SEAL-----	1
8	9S8008	PLUG-----	1
8	3D2824	SEAL-----	1
9	2S5816	SPRING-----	1
10	4J6064	ELEMENT ASSEM. --- (Disposable)---	1
11	3S9847	RETAINER-----	1
12	9S4205	PLUG-----	1
13	7M8485	SEAL-----	1
14	2H3788	NUT-----	1
15	2P2891	HOUSING-----	1
16	1P9600	SPOOL-----	1
17	8S1813	TERMINAL-----	1
18	1P2086	SCREW-----	1
	4L1250	NUT-----	1
C 19	3P3668	INSULATOR-----	2
C 20	5P369	SEAL-----	1

C INDICATES CHANGE

8S666 TRANSMISSION FILTER GROUP  
 Part of Transmission and Steering Clutch Lubrication  
 System shown on Pages 68, 71, 74 & 77

STEERING CLUTCH HYDRAULIC CONTROL (3S2036 N/S)  
Serial No. 11K5051 to 11K5672 inclusive

1P968 Steering Clutch Hydraulic Valve parts are shown on Page 83B

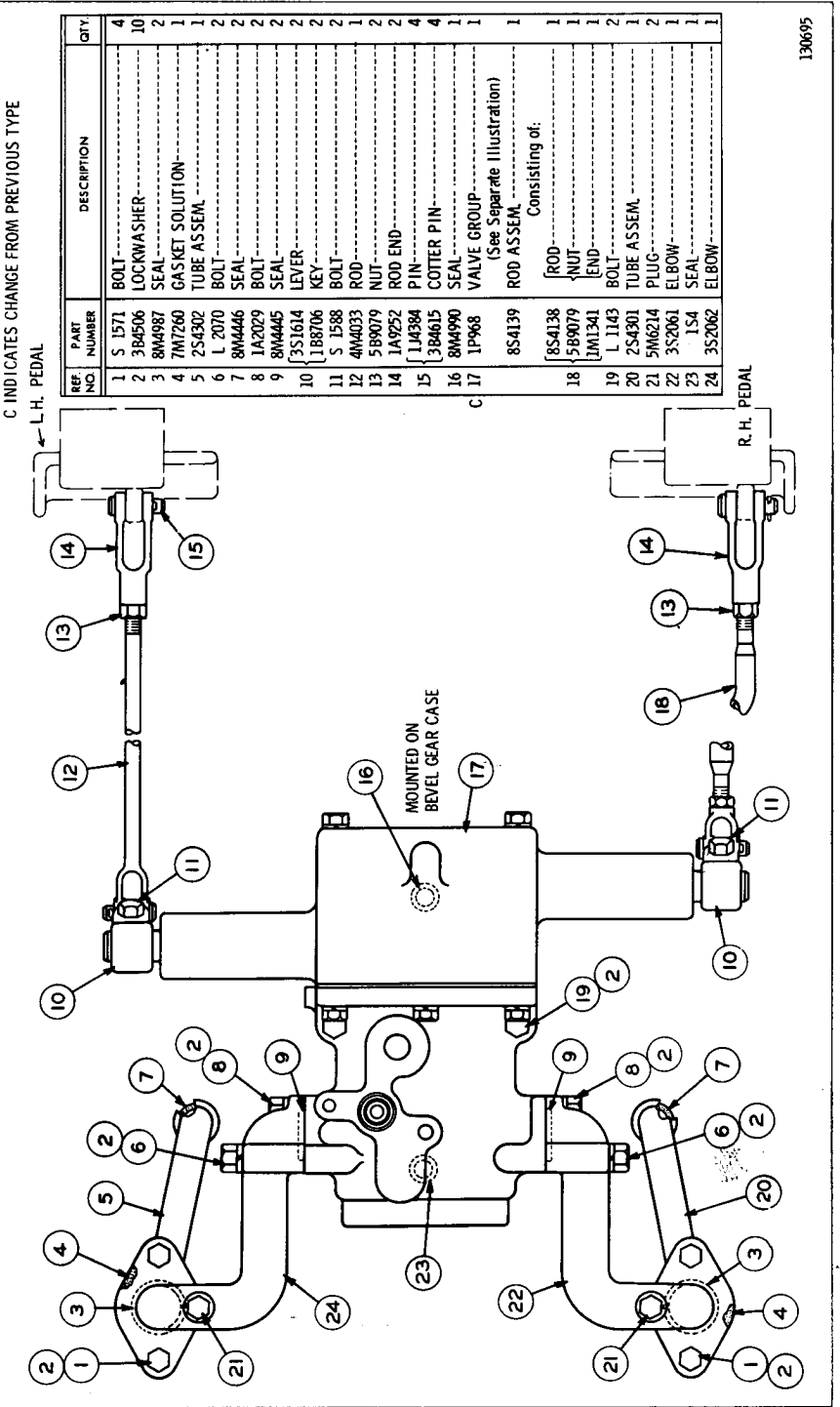

C INDICATES CHANGE FROM PREVIOUS TYPE

L.H. PEDAL

R.H. PEDAL

REF. NO.	PART NUMBER	DESCRIPTION	QTY.
1	S 1571	BOLT	4
2	3B4506	LOCKWASHER	10
3	8M4987	SEAL	2
4	7M7260	GASKET SOLUTION	1
5	254502	TUBE ASSEM.	1
6	L 2070	BOLT	2
7	8M4446	SEAL	2
8	1A2029	BOLT	2
9	8M4445	SEAL	2
10	3S1614	LEVER	2
11	1B8706	KEY	2
12	S 1588	BOLT	2
13	4M4033	ROD	1
14	5B9079	NUT	2
15	1A9252	ROD END	2
16	1J4384	PIN	4
17	3B4615	COTTER PIN	4
18	8M4990	SEAL	4
19	1P968	VALVE GROUP (See Separate Illustration)	1
20	854139	ROD ASSEM.	1
21	854138	ROD	1
22	5B9079	NUT	1
23	1M1341	END	1
24	L 1143	BOLT	2
25	254301	TUBE ASSEM.	1
26	5M6214	PLUG	2
27	3S2061	ELBOW	1
28	1S4	SEAL	1
29	3S2062	ELBOW	1

Consisting of:

REF. NO.	PART NUMBER	DESCRIPTION	QTY
1	51571	BOLT	4
2	3B4506	LOCKWASHER	10
3	8M4987	SEAL	2
4	7M7260	GASKET SOLUTION	1
5	2S4302	TUBE ASSEM.	1
6	L2070	BOLT	2
7	8M4446	SEAL	2
8	1A2029	BOLT	2
9	8M4445	SEAL	2
10	3S1614	LEVER	2
11	1B8706	KEY	2
12	51588	BOLT	2
13	4M4033	ROD	1
14	5B9079	NUT	2
15	1A9252	ROD END	2
16	1J4384	PIN	4
17	3B4615	COTTER PIN	4
18	8M4990	SEAL	1
19	2P4040	VALVE GROUP	1
		(Separate Illustration)	
	8S4139	ROD ASSEM.	1
		(Includes)	
18	8S4138	ROD	1
	5B9079	NUT	1
	11M1341	END	1
19	L1143	BOLT	2
20	2S4301	TUBE ASSEM.	1
21	5M6214	PLUG	2
22	3P6187	ELBOW	2
23	1S4	SEAL	1
24	3P6188	ELBOW	1

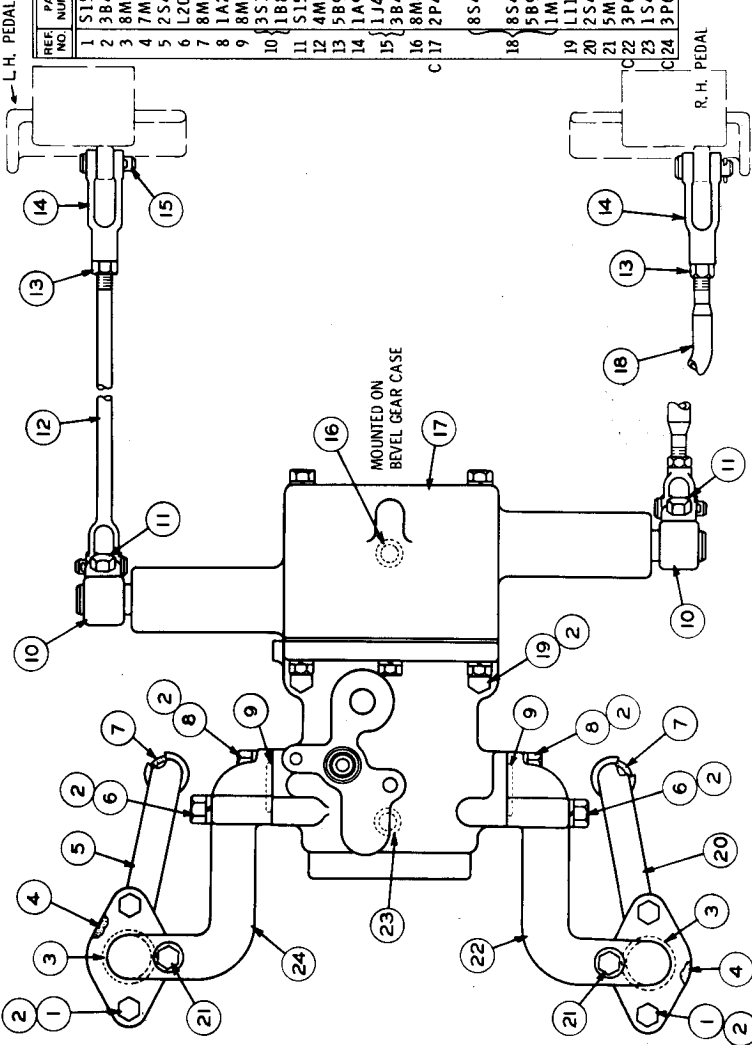

147264

C INDICATES CHANGE

STEERING CLUTCH HYDRAULIC CONTROL (3S2036 N/S)

Serial No. 11K5673—Up

2P4040 Control Valve parts are shown on Page 84



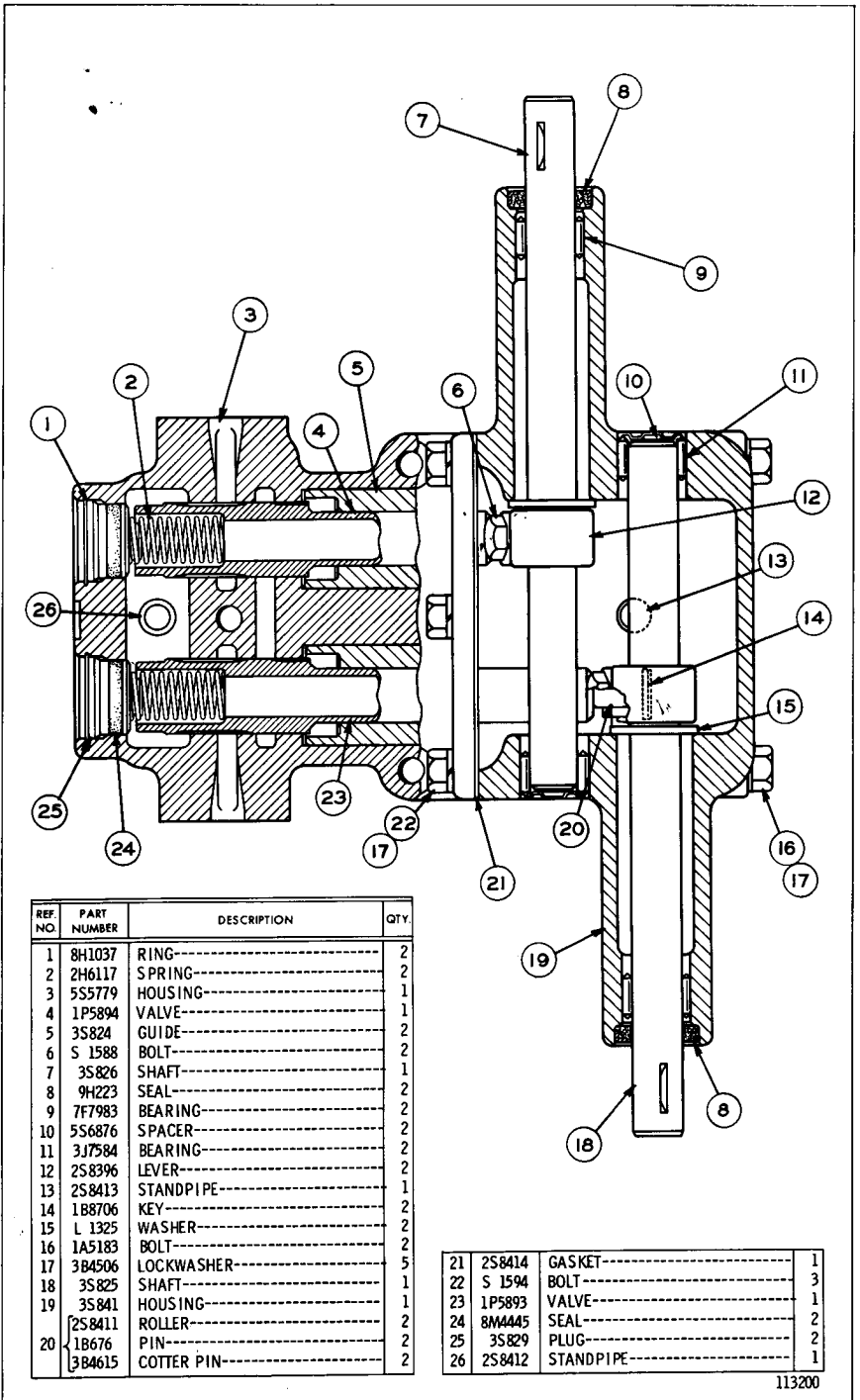

REF. NO.	PART NUMBER	DESCRIPTION	QTY.
1	8H1037	RING-----	2
2	2H6117	SPRING-----	2
3	5S5779	HOUSING-----	1
4	1P5894	VALVE-----	1
5	3S824	GUIDE-----	2
6	S 1588	BOLT-----	2
7	3S826	SHAFT-----	1
8	9H223	SEAL-----	2
9	7F7983	BEARING-----	2
10	5S6876	SPACER-----	2
11	3J7584	BEARING-----	2
12	2S8396	LEVER-----	2
13	2S8413	STANDPIPE-----	1
14	1B8706	KEY-----	2
15	L 1325	WASHER-----	2
16	1A5183	BOLT-----	2
17	3B4506	LOCKWASHER-----	5
18	3S825	SHAFT-----	1
19	3S841	HOUSING-----	1
20	2S8411	ROLLER-----	2
	1B676	PIN-----	2
	3B4615	COTTER PIN-----	2

21	2S8414	GASKET-----	1
22	S 1594	BOLT-----	3
23	1P5893	VALVE-----	1
24	8M4445	SEAL-----	2
25	3S829	PLUG-----	2
26	2S8412	STANDPIPE-----	1

113200

1P968 STEERING CLUTCH HYDRAULIC VALVE GROUP  
 Serial No. 11K5051 to 11K5672 inclusive  
 Part of Steering Clutch Hydraulic Control shown on Page 83

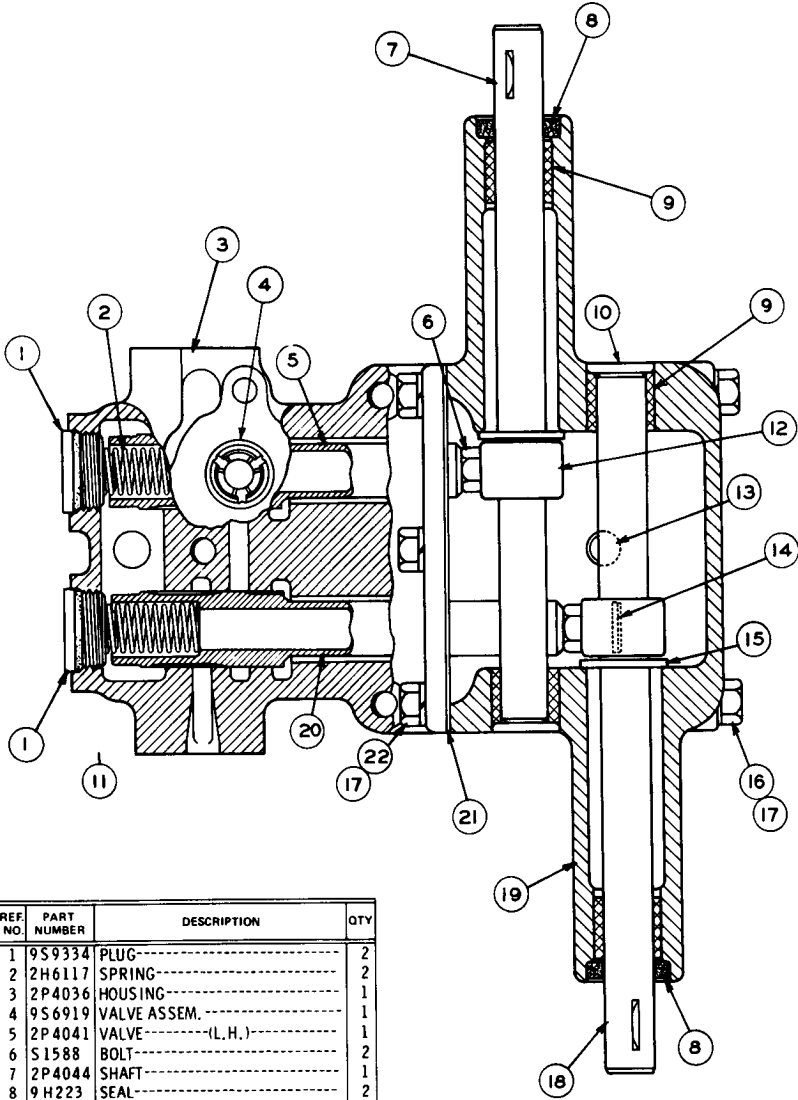

REF NO.	PART NUMBER	DESCRIPTION	QTY
1	9S9334	PLUG-----	2
2	2H6117	SPRING-----	2
3	2P4036	HOUSING-----	1
4	9S6919	VALVE ASSEM.-----	1
5	2P4041	VALVE----- (L.H.)-----	1
6	S1588	BOLT-----	2
7	2P4044	SHAFT-----	1
8	9H223	SEAL-----	2
9	2P4054	BEARING-----	4
10	4K8603	PLUG-----	2
11	7L2229	SEAL-----	2
12	2P4045	LEVER-----	2
13	2P4048	PIN-----	1
14	1B8706	KEY-----	2
15	L1325	WASHER-----	2
16	1A5183	BOLT-----	2
17	3B4506	LOCKWASHER-----	5
18	2P4043	SHAFT-----	1
19	2P4891	HOUSING-----	1

C 20	2P4042	VALVE----- (R.H.)-----	1
21	2S8414	GASKET-----	1
22	S1594	BOLT-----	3

C INDICATES CHANGE

151302

2P4040 CONTROL VALVE GROUP

Serial No. 11K5673 to 11K6531 and 11K6533 to 11K6535 inclusive  
 Part of Steering Clutch Hydraulic Control shown on Page 83A

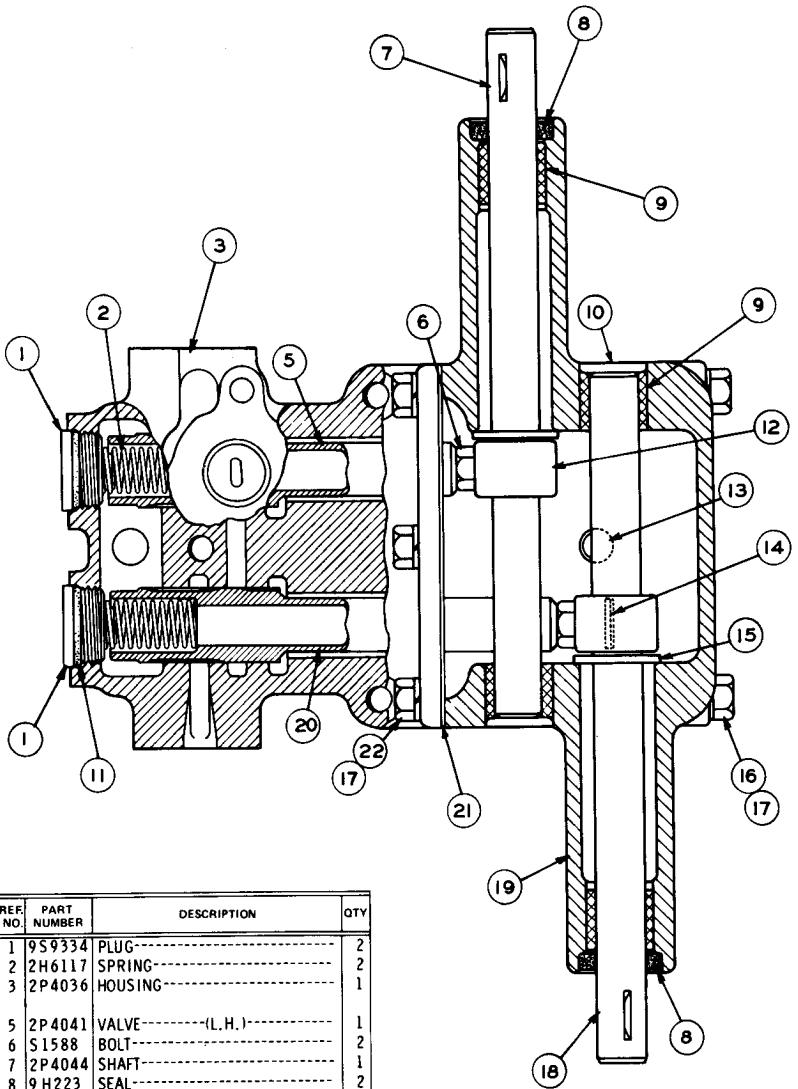

REF. NO.	PART NUMBER	DESCRIPTION	QTY
1	9S9334	PLUG-----	2
2	2H6117	SPRING-----	2
3	2P4036	HOUSING-----	1
5	2P4041	VALVE----- (L. H.)-----	1
6	51588	BOLT-----	2
7	2P4044	SHAFT-----	1
8	9H223	SEAL-----	2
9	9H8751	BEARING-----	4
C 10	4K8603	PLUG-----	2
11	7L2229	SEAL-----	2
12	2P4045	LEVER-----	2
C 13	2S8413	STANDPIPE-----	1
14	188706	KEY-----	2
15	L1325	WASHER-----	2
16	1A5183	BOLT-----	2
17	3B4506	LOCKWASHER-----	5
18	2P4043	SHAFT-----	1
19	2P4891	HOUSING-----	1

20	2P4042	VALVE----- (R. H.)-----	1
21	2S8414	GASKET-----	1
22	S1594	BOLT-----	3

C INDICATES CHANGE

151303

2P4040 CONTROL VALVE GROUP  
 Serial No. 11K6532 and 11K6536—Up  
 Part of Steering Clutch Hydraulic Control shown on Page 83A

STEERING CLUTCH (1S1713N/S)

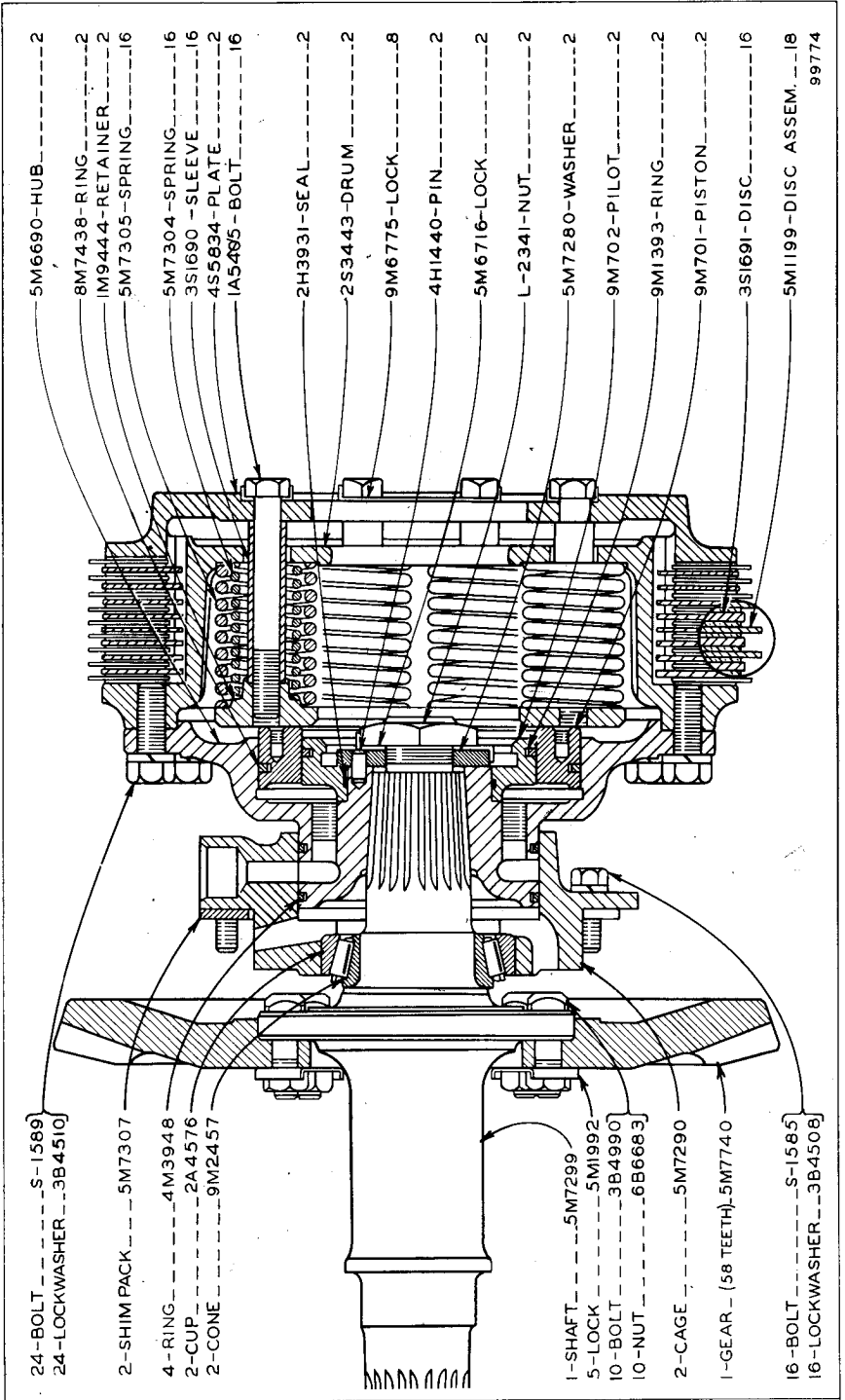

GMC00070-FORM ..... 1  
 (Instructions for installing  
 953325 Support Assem.)

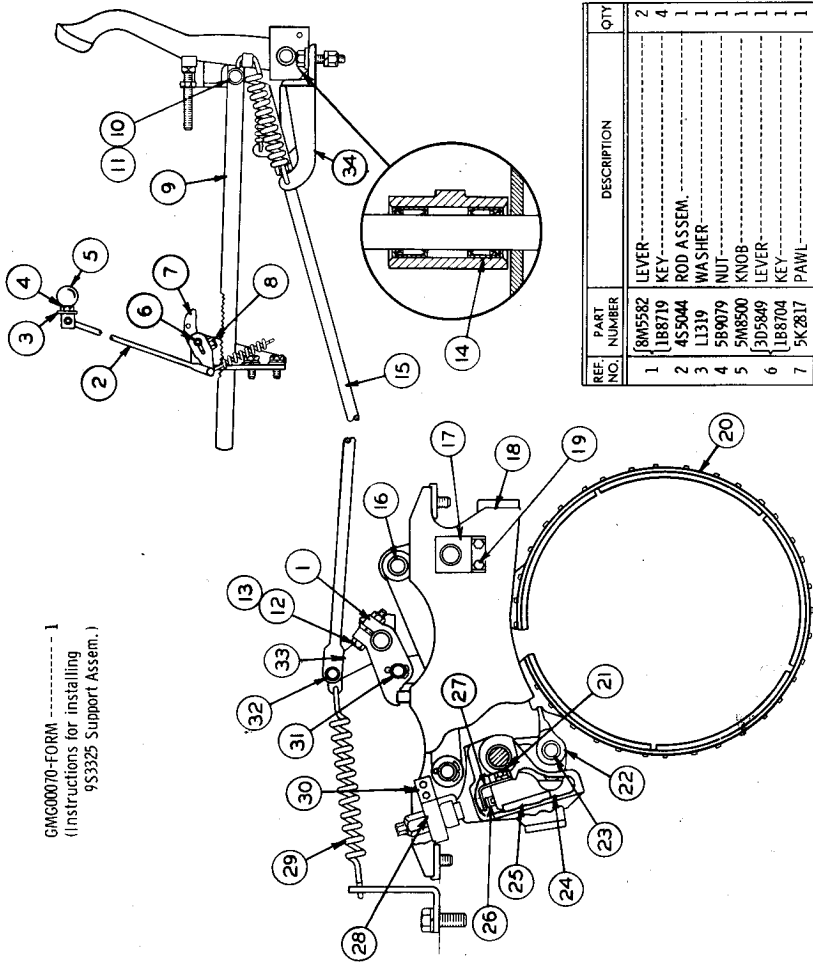

REF. NO.	PART NUMBER	DESCRIPTION	QTY
1	8M5582	LEVER	2
2	1B8719	KEY	4
3	4S5044	ROD ASSEM.	1
4	1L1319	WASHER	1
5	5M8500	NUT	1
6	3D5849	KNOB	1
7	1B8704	LEVER	1
	5K2817	KEY	1
		PAWL	1

8	51616	BOLT	1
9	5K6309	RATCHET	1
10	5175	PIN	1
11	3B4617	COTTER PIN	1
12	51577	BOLT	2
		(-Fine Thread)	
	1B4206	NUT	2
		-OR-	
	8S9092	BOLT	2
		(-Coarse Thread)	
13	1D4720	NUT	2
14	6K8088	BEARING	10
15	3S3044	ROD	2
16	8H376	PIN	4
	8H350	RING	8
17	8M5587	SHAFT ASSEM.	4
18	8M5589	SUPPORT ASSEM.	2
19	1T102	BOLT	8
	5B2200	LOCK	4
20	9M8068	BAND AND LINING ASSEM.	2
		(See Separate Illustration)	
21	1L1351	BOLT	2
22	3B4506	LOCKWASHER	2
23	1M3778	STRUT	4
	1M3788	PIN	4
	1K9740	RING	8
24	7S6148	LEVER ASSEM.	2
25	1M4025	WEDGE	2
26	2M7188	SCREW	2
27	5H6624	SUPPORT	2
28	9S8220	SPRING	2
29	9H6700	SPRING	2
30	2F6156	LOCK	4
31	4H8493	PIN	2
	3B4629	COTTER PIN	2
	9S1315	PIN	2
32	3B4617	COTTER PIN	2
33	7M3417	LINK	2
34	953325	SUPPORT ASSEM.	1

113415

Serial No. 11K5051 to 11K6339 inclusive. 9M8068 Band and Lining parts are shown on Page 88  
 Note: Quantities shown are those required for R.H. and L.H. sides

BRAKES (3S2034 N/S)—Side View

**BRAKES (3S2034 N/S)—Top View**  
 Serial No. 11K5051 to 11K6339 inclusive

Note: Quantities shown are those required for both R.H. and L.H. sides

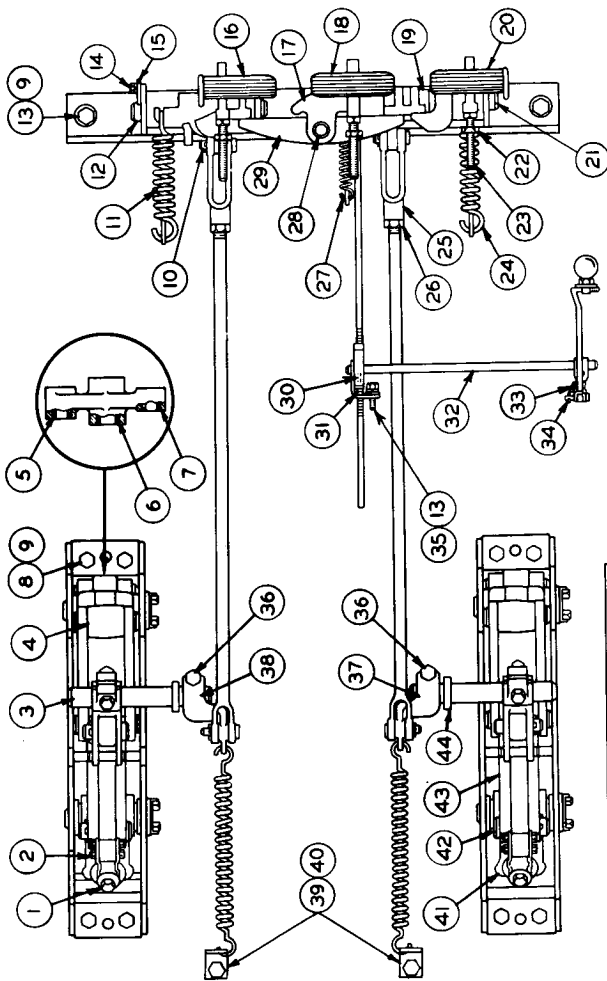

REF. NO.	PART NUMBER	DESCRIPTION	QTY
1	1P4524	SOCKET	2
2	1B9575	BOLT	4
3	1D4717	NUT	4
4	8M7175	SHAFT	2
5	7S6149	LEVER ASSEM.	2
6	8H356	BUSHING	2
7	1M3834	BUSHING	2

8	4B4043	BOLT	8
9	3B4510	LOCKWASHER	14
10	9S1315	PIN	2
11	3B4617	COTTER PIN	2
12	7B5594	SPRING	1
	3S5052	SHAFT	1
		(Left Hand)	1

13	S1589	BOLT	2
	1D4720	NUT	2
	4D3704	WASHER	2
14	L1351	BOLT	4
	3B4506	LOCKWASHER	4
15	L1032	LOCK	2
16	9S4232	BRAKE PEDAL	1
		(Left Hand)	1
17	2S3813	SMUBBER	1
	7F2770	ADHESIVE	1
18	9S4233	BRAKE PEDAL	1
		(Middle)	1
19	9S4229	LEVER	2
20	9S4231	BRAKE PEDAL	1
		(Right Hand)	1
21	3S3051	SHAFT	1
		(Right Hand)	1
22	1D5117	NUT	3
23	4B3589	SCREW	3
24	7B5594	SPRING	1
25	9S1314	ROD END	2
26	9S1354	NUT	2
27	1M437	SPRING	1
28	9F3051	PIN	1
29	3B4529	COTTER PIN	1
30	3S3042	BAR	1
31	9F7882	PIN	1
32	4S9014	BRACKET	1
33	3S3865	SHAFT	1
34	4F6123	SPRING	1
35	9S1303	PIN	1
36	4B4278	WASHER	1
37	S1589	BOLT	2
	3S3045	LEVER	1
		(Right Hand)	1
38	3S3046	LEVER	1
		(Left Hand)	1
39	4M4982	SUPPORT	2
40	6H1717	BOLT	2
	3B4508	LOCKWASHER	2
41	4S9104	LEVER ASSEM.	2
42	8H8898	PIN	2
43	3B4632	COTTER PIN	2
44	7S6139	LINK	8
	9H8839	SEAL	2

112416

GMG00070-FORM ..... 1  
 (Instructions for installing  
 953325 Support Assem.)

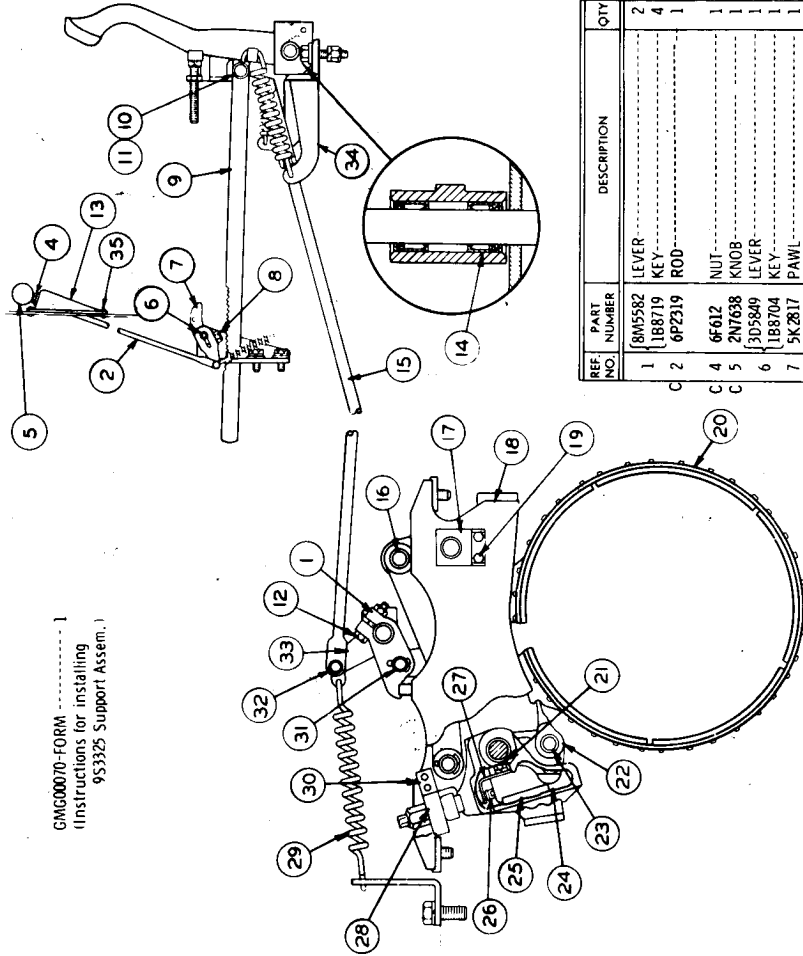

REF NO.	PART NUMBER	DESCRIPTION	QTY
1	8M5582	LEVER	2
1	1B8719	KEY	4
2	6P2319	ROD	1
4	6F612	NUT	1
5	2N7638	KNOB	1
6	3D5849	LEVER	1
6	1B8704	KEY	1
7	5K2817	PAWL	1

8	51616	BOLT	1
9	5K6309	RATCHET	9
10	5175	PIN	1
11	3B4617	COTTER PIN	1
12	51577	BOLT	2
12	1B4206	NUT	2
13	3P2316	COVER ASSEM. (Includes)	1
14	6P2318	BEARING	10
14	6K8088	BEARING	2
15	3S3044	ROD	4
16	8H376	PIN	4
16	8H350	RING	4
17	8M5587	SHAFT ASSEM.	4
18	8M5589	SUPPORT ASSEM.	2
19	1102	BOLT	8
19	5B2200	LOCK	4
20	9M8068	BAND AND LINING ASSEM. (See Separate Illustration)	2
21	11351	BOLT	2
21	3B4506	LOCKWASHER	2
22	1M3778	STRUT	4
23	1M3788	PIN	4
23	1K9740	RING	8
24	7S6148	LEVER ASSEM.	2
25	1M4025	WEDGE	2
26	2M7188	SCREW	2
27	5H6624	SUPPORT	2
28	9S820	SPRING	2
29	9H6700	SPRING	2
30	2F6156	LOCK	4
31	4H8493	PIN	2
31	3B4629	COTTER PIN	2
32	951315	PIN	2
32	3B4617	COTTER PIN	2
33	7M3417	LINK	2
34	953325	SUPPORT ASSEM.	1
35	337291	RIVET	2

C INDICATES CHANGE

150974

BRAKES (3S2034 N/S)—Side View  
 Serial No. 11K6340—Up. 9M8068 Band and Lining parts are shown on Page 88  
 Note: Quantities shown are those required for both R.H. and L.H. sides

BRAKES (3S2034 N/S)—Top View

Serial No. 11K6340—Up

Note: Quantities shown are those required for both R.H. and L.H. sides

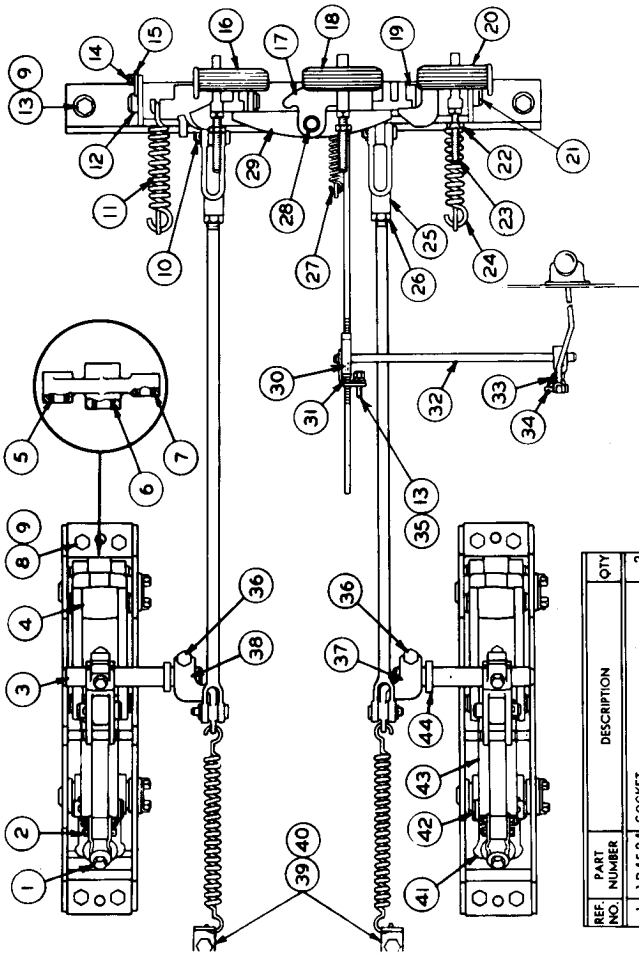

REF. NO.	PART NUMBER	DESCRIPTION	QTY
1	1P4524	SOCKET	2
2	1B9575	BOLT	4
3	8M7175	SHAFT	2
4	7S6149	LEVER ASSEM.	2
5	84356	BUSHING	2
6	84355	BUSHING	2
7	1M3834	BUSHING	1

8	4B4043	BOLT	8
9	3B4510	LOCKWASHER	14
10	9S1315	PIN	2
11	3B4617	COTTER PIN	2
12	7B5594	SPRING	1
	3S3052	SHAFT	1

13	51589	BOLT	2	
	1D4720	NUT	2	
	4D3704	WASHER	2	
14	11351	BOLT	4	
	3B4506	LOCKWASHER	4	
15	11032	LOCK	2	
16	9S4232	BRAKE PEDAL	1	
17	2S3813	SNUBBER	1	
	7F2770	ADHESIVE	1	
18	9S4233	BRAKE PEDAL	1	
19	9S4229	LEVER	1	
20	9S4231	BRAKE PEDAL	1	
21	3S3051	SHAFT	1	
22	1D5117	NUT	1	
23	4B3589	SCREW	3	
24	7B5594	SPRING	3	
25	9S1314	ROD END	1	
26	9S1354	NUT	2	
27	1M437	SPRING	1	
28	9F3051	PIN	1	
29	3B4529	COTTER PIN	1	
30	3S3042	BAR	1	
31	9F7882	PIN	1	
32	1A59014	BRACKET	1	
33	3S3865	SHAFT	1	
34	4F6123	SPRING	1	
35	9S1303	PIN	1	
36	4B4278	WASHER	1	
37	51589	BOLT	2	
38	3S3045	LEVER	1	
39	3S3046	LEVER	1	
40	4M4982	SUPPORT	2	
	6H1717	BOLT	2	
	3B4508	LOCKWASHER	2	
	41	4S9104	LEVER ASSEM.	2
	42	8H8898	PIN	2
	43	3B4632	COTTER PIN	2
	44	7S6139	LINK	2
	44	9H8839	SEAL	2

15192



CATERPILLAR 977L TRAXCAVATOR

▲ 8S2515-BRAKE LINING GROUP--(molded) -2  
Each consisting of a complete set of Linings and Rivets for one Brake

▲ 5S1513-BRAKE LINING GROUP--(woven) -2  
Each consisting of:  
{ 2S4297-LINING -----(woven)-----5  
{ 7B5060-RIVET ----- 65

REF. NO.	PART NUMBER	DESCRIPTION	QTY
1	5S5658	LINING-----	5
3	7B5060	RIVET-----	65

▲ NOT PART OF 9M8068 BRAKE ASSEM.

200433

9M8068 BRAKE BAND ASSEMBLY—2 Required  
Part of Brakes shown on Page 86

2S4297-LINING\_(DRILLED).5

5S1503-BRAKE LINING GROUP\_2  
EACH CONSISTING OF A COMPLETE SET OF LININGS AND RIVETS FOR ONE BRAKE.

7B5060-RIVET-----65

78827

5S1503 BAND AND LINING ASSEMBLY—2 Required  
Part of 5S3270, 1P9409 and 3P1469 Steel Mill Traxcavator Arrangements listed on Pages 103, 104 and 104A. AN ATTACHMENT

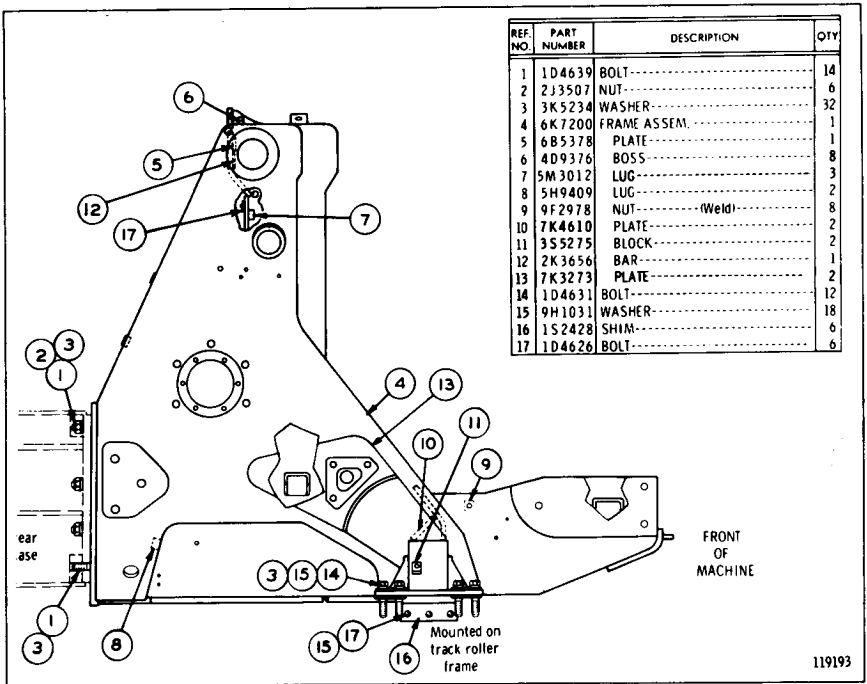

**LOADER FRAME (7K111 N/S)**  
Serial No. 11K5051 to 11K5416 inclusive

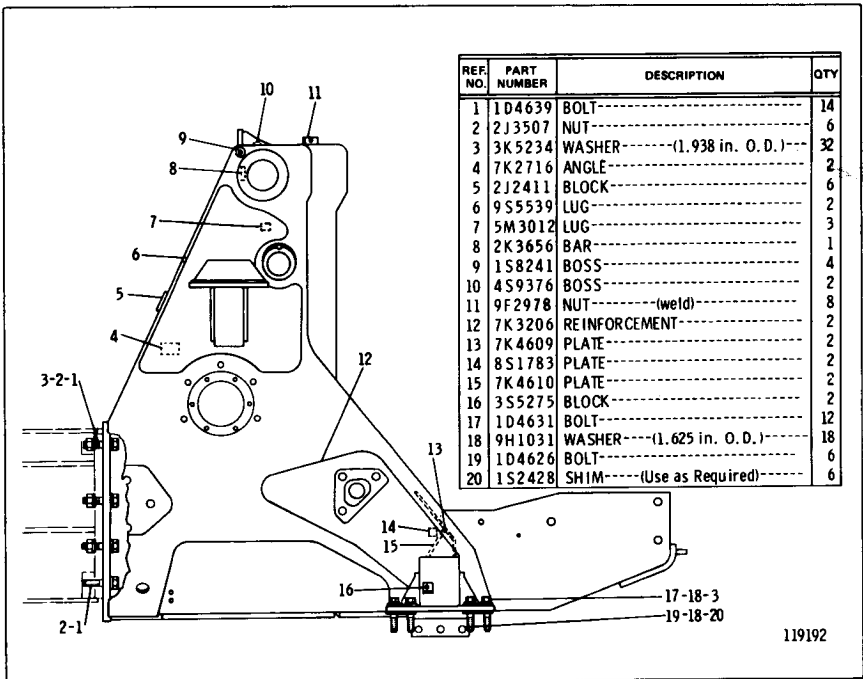

**LOADER FRAME (3P6270 N/S)**  
Serial No. 11K5417 to 11K6423 inclusive

LOADER FRAME (6P3325 N/S)  
Serial No. 11K6424—Up

REF. NO.	PART NUMBER	DESCRIPTION	QTY
1	1D4639	BOLT	14
2	2J3507	NUT	6
3	3K5234	WASHER	32
4	1D4626	BOLT	6
5	9H1031	WASHER	18
6	1S2428	SHIM	6
7	1D4631	BOLT	12
8	6P2286	FRAME ASSEM. (Includes)	1
9	2J2411	BLOCK	6
10	7K2716	ANGLE	2
11	9S5539	LUG	2
12	1B2588	BOSS	2
13	1S8241	BOSS	4
14	4S9376	BOSS	2
15	2K3656	BAR	1
16	5B8855	PLATE	1
17	6F3259	LUG	1
18	5M3012	LUG	3
19	7K3206	REINFORCEMENT PLATE	2
20	7K4609	PLATE	2
21	8S1783	PLATE	2
22	7K4610	PLATE	2
23	5H9409	LUG	2
24	6K2107	BLOCK	4
25	3S5275	BLOCK	2
26	9F2978	NUT	8
27	8F9836	LUG	1

150572

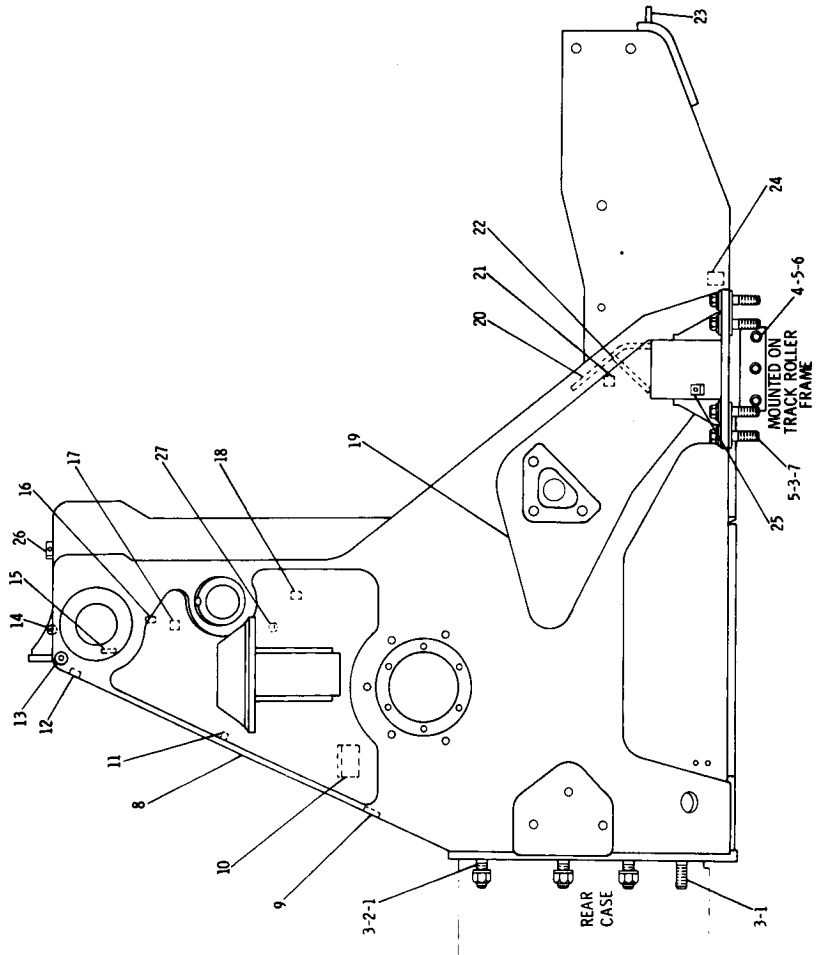

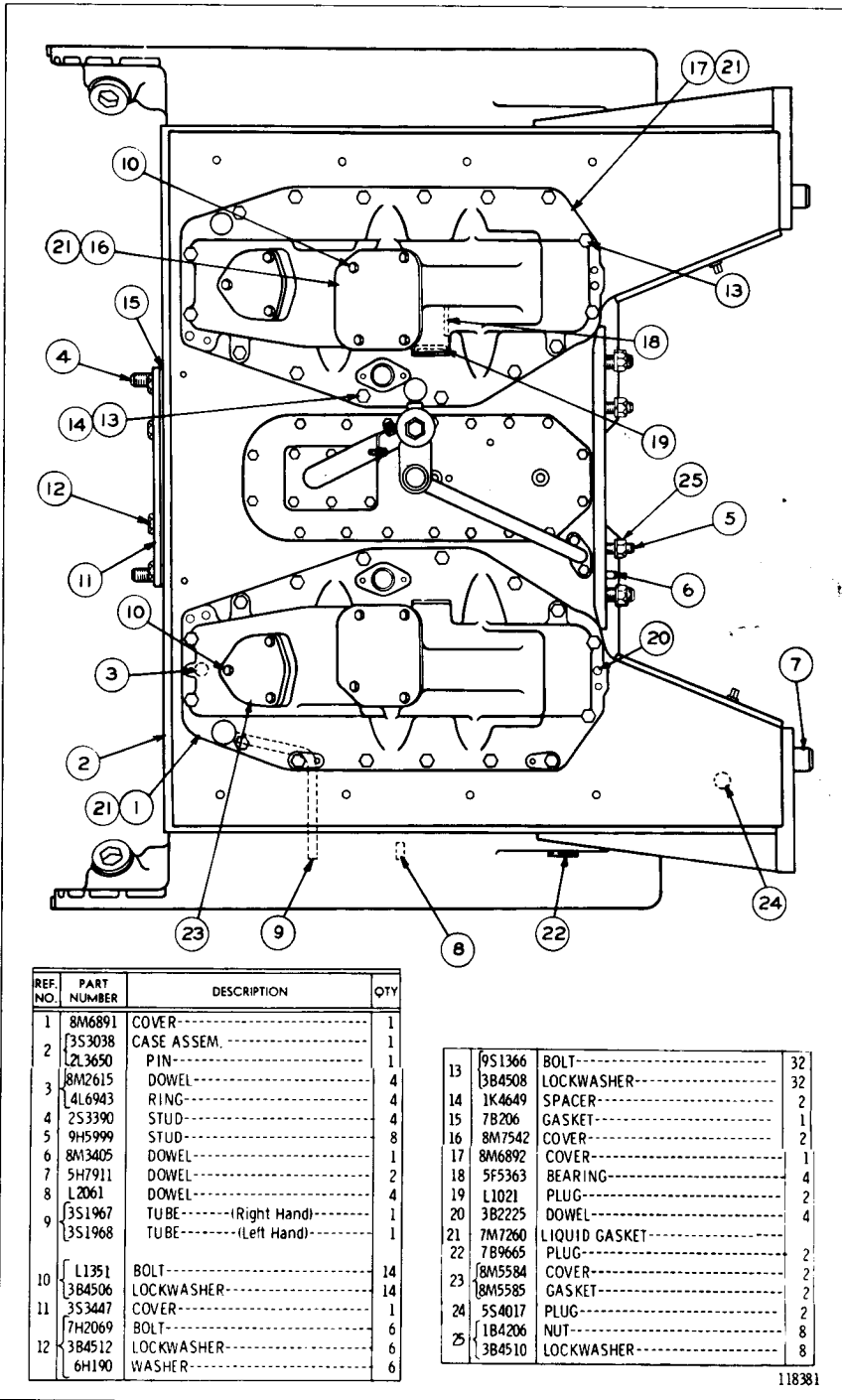

118381

BEVEL GEAR CASE AND COVERS (3S2035 N/S)—Part 1  
Serial No. 11K5051 to 11K5116 inclusive

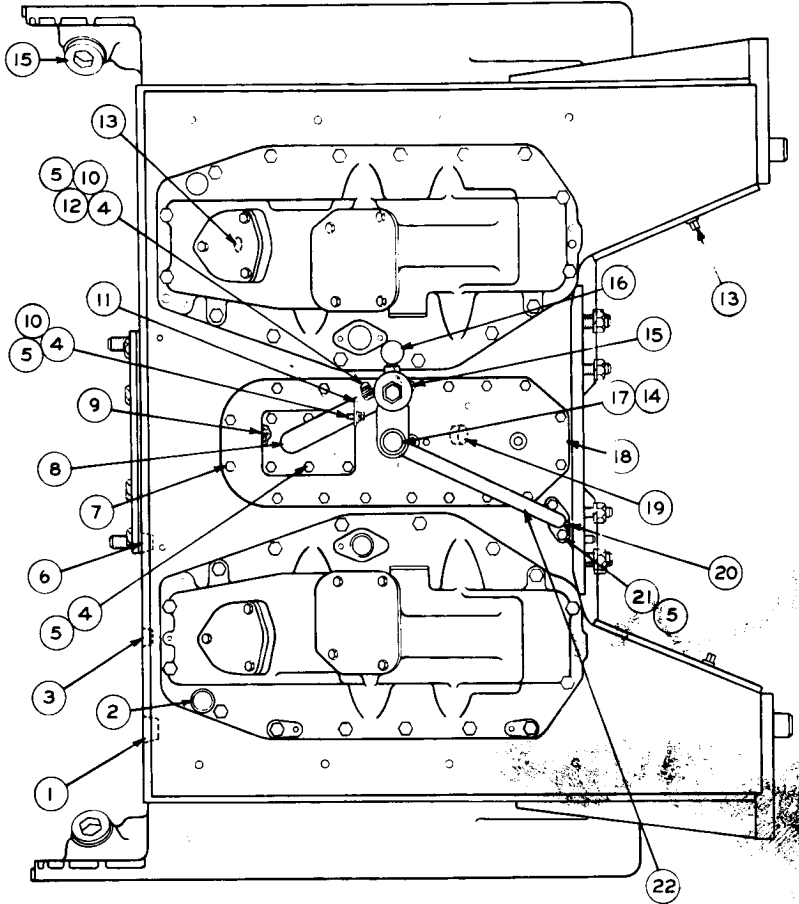

REF NO	PART NUMBER	DESCRIPTION	QTY
1	7M4515	CORK-----	6
	8S5820	BREATHER-----	2
2	3B6488	COUPLING-----	2
	5B7442	NIPPLE-(.25" diameter-4.75" long)-----	2
3	2B7561	CORK-----	8
4	L1351	BOLT-----	8
5	3B4506	LOCKWASHER-----	10
6	2B7583	CORK-----	2
7	1C2251	BOLT-----	18
	5M2894	WASHER-----	18
	3S5694	SPOUT ASSEM.-----	1
8	2S2053	CLIP-----	1
	9M1939	GASKET-----	1
10	4B4278	WASHER-----	2
11	2S3822	BRACKET-----	1
12	1D4717	NUT-----	1

13	2B7409	PLUG-----	3
14	1M4543	GROMMET-----	1
	8L827	PLUG-----	3
15	8L1124	GASKET-----	3
	8S5820	BREATHER-----	1
16	3B6553	ELBOW-----	1
	3P596	PLUNGER ASSEM.-----	1
	7F7968	CAP-----	1
17	7F1539	REINFORCEMENT-----	2
	7F1540	RIVET-----	2
	3S1740	PLATE-----	1
18	7M7260	GASKET SOLUTION-----	1
19	5S4017	PLUG-----	1
20	7M1588	GASKET-----	1
21	S1594	BOLT-----	2
C 22	3P597	GUIDE ASSEM.-----	1

C INDICATES CHANGE

118382

BEVEL GEAR CASE AND COVERS (3S2035 N/S)—Part 2  
Serial No. 11K5051 to 11K5116 inclusive

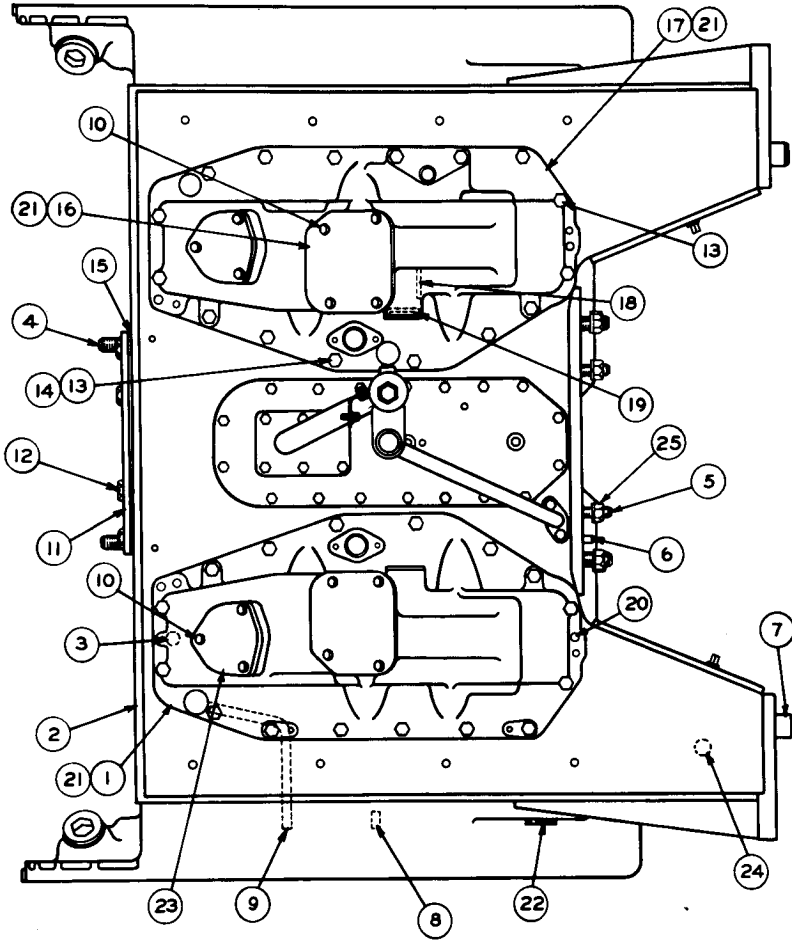

REF. NO.	PART NUMBER	DESCRIPTION	QTY
1	8M6891	COVER	1
2	3S3038	CASE ASSEM.	1
	2L3650	PIN	1
3	8M2615	DOWEL	4
	4L6943	RING	4
4	2S3390	STUD	4
5	9H5999	STUD	8
6	8M3405	DOWEL	1
7	5H7911	DOWEL	2
8	L2061	DOWEL	4
9	3S1967	TUBE (Right Hand)	1
	3S1968	TUBE (Left Hand)	1
10	L1351	BOLT	14
	3B4506	LOCKWASHER	14
11	3S3447	COVER	1
	7H2069	BOLT	6
12	3B4512	LOCKWASHER	6
	6H190	WASHER	6

13	9S1366	BOLT	32
	3B4508	LOCKWASHER	32
14	1K4549	SPACER	2
15	7B206	GASKET	1
16	8M7542	COVER	2
C 17	3P3930	COVER	1
C 17	3S8313	PLUG	1
18	5F5363	BEARING	4
19	L1021	PLUG	2
20	3B2225	DOWEL	4
21	7M7260	LIQUID GASKET	1
22	7B9665	PLUG	2
23	8M5584	COVER	2
	8M5585	GASKET	2
24	5S4017	PLUG	2
	1B4206	NUT	8
25	3B4510	LOCKWASHER	8

C INDICATES CHANGE

118383

BEVEL GEAR CASE AND COVERS (3S2035 N/S)—Part 1  
Serial No. 11K5117—Up

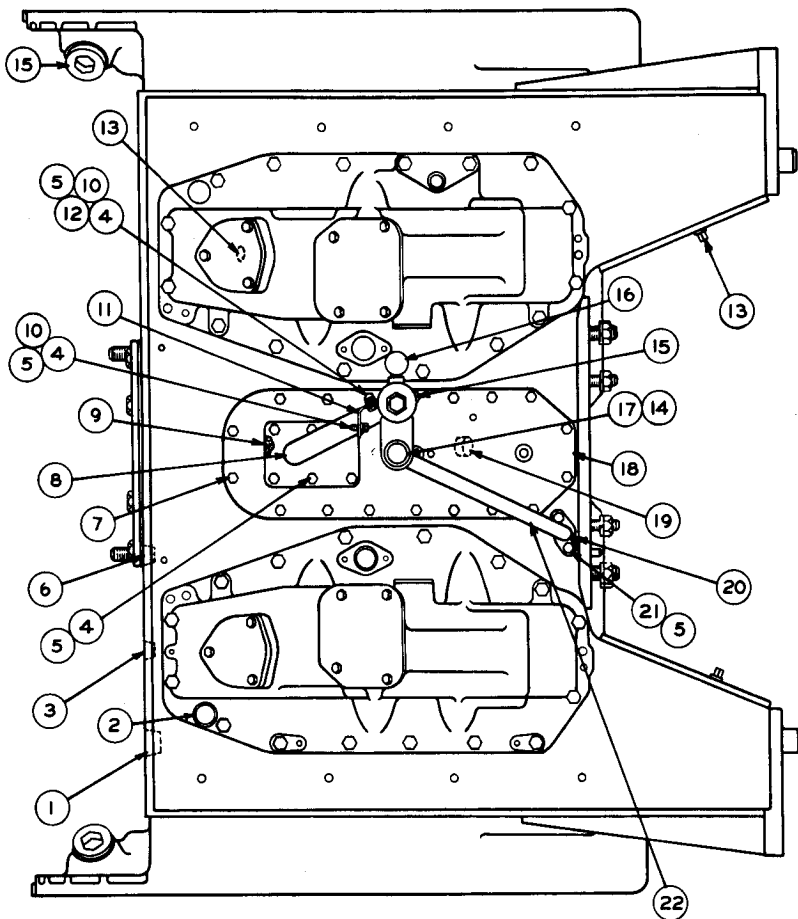

REF. NO.	PART NUMBER	DESCRIPTION	QTY
1	7M4515	CORK-----	6
	8S5820	BREATHER-----	2
2	3B6488	COUPLING-----	2
	3B7273	NIPPLE-----	2
3	2B7561	CORK-----	8
4	L1351	BOLT-----	8
5	3B4506	LOCKWASHER-----	10
6	2B7583	CORK-----	2
	1C2251	BOLT-----	18
7	5M2894	WASHER-----	18
	3S5694	SPOUT ASSEM.-----	1
8	2S2053	CLIP-----	1
9	9M1939	GASKET-----	1
10	4B4278	WASHER-----	2
11	2S3822	BRACKET-----	1
12	104717	NUT-----	1

13	2B7409	PLUG-----	3
14	1M4543	GROMMET-----	1
	L827	PLUG-----	3
15	L1124	GASKET-----	3
	8S5820	BREATHER-----	1
16	3B6553	ELBOW-----	1
	3P596	PLUNGER ASSEM.-----	1
	7F7968	CAP-----	1
17	7F1539	REINFORCEMENT-----	2
	7F1540	RIVET-----	2
	3S1740	PLATE-----	1
18	7M7260	GASKET SOLUTION-----	1
19	5S4017	PLUG-----	1
20	7M1588	GASKET-----	1
21	S1594	BOLT-----	2
22	3P597	GUIDE ASSEM.-----	1

C INDICATES CHANGE

118384

BEVEL GEAR CASE AND COVERS (3S2035 N/S)—Part 2  
Serial No. 11K5117—Up

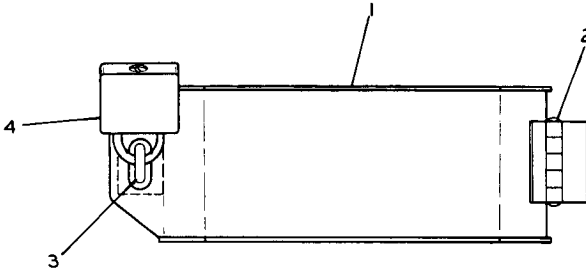

REF. NO.	PART NUMBER	DESCRIPTION	QTY
1	2P8352	COVER ASSEM.-----	1
2	5B866	HINGE-----	1
3	8F5240	STAPLE-----	1
4	8S7949	PADLOCK GROUP-----	1
	8M439	KEY-----	2

113909

2P7611 PROTECTION COVER GROUP—Bevel Gear Case Filler Pipe  
 Also part of 2P5300 Vandalism Protection Arrangement listed on Page 227  
 AN ATTACHMENT



CRANKCASE GUARD (6K8368 N/S)

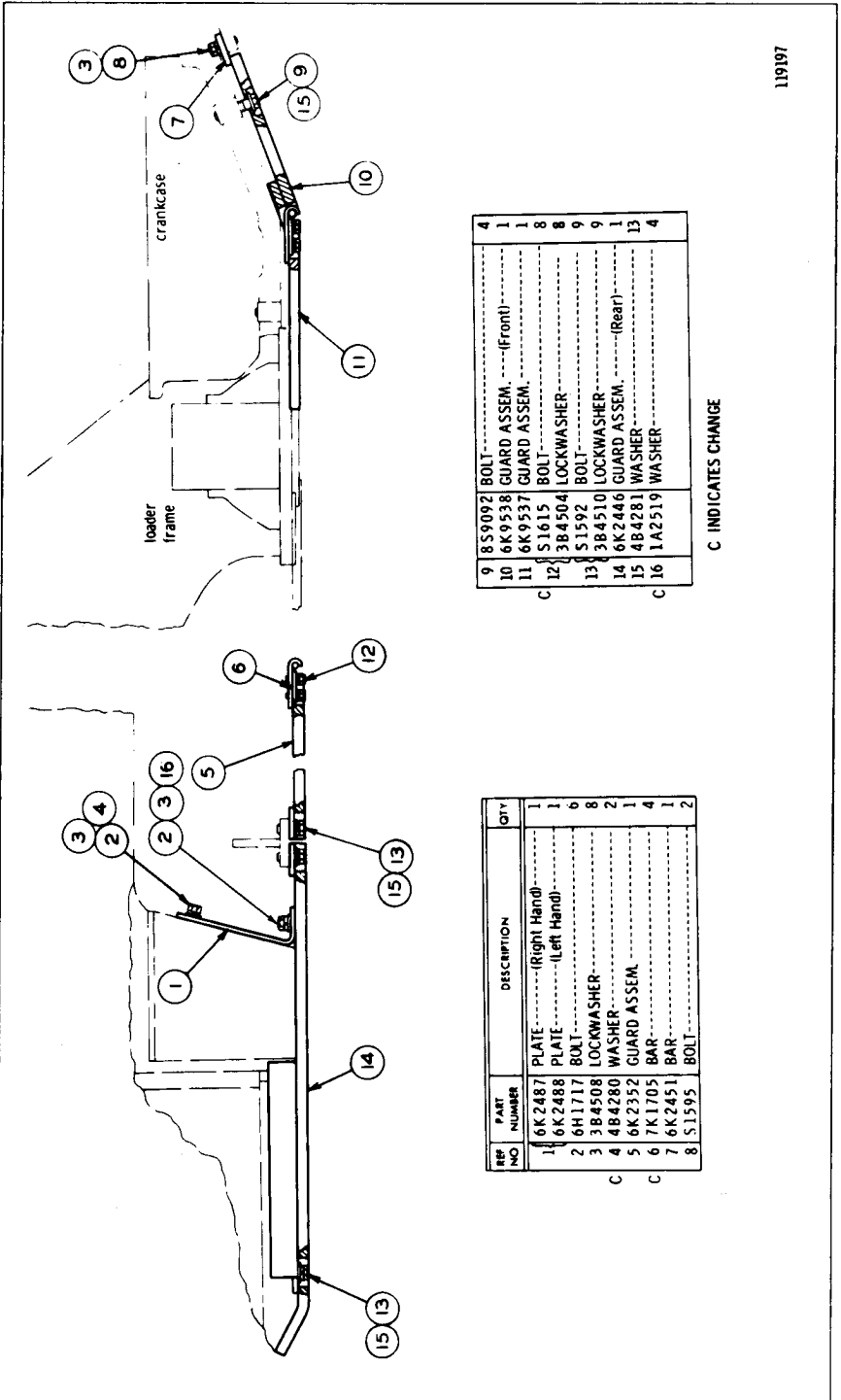

REP NO	PART NUMBER	DESCRIPTION	QTY
1	6K2487	PLATE.....(Right Hand)	1
2	6K2488	PLATE.....(Left Hand)	1
3	6H1717	BOLT.....	6
3	3B4508	LOCKWASHER.....	8
4	4B4280	WASHER.....	2
5	6K2352	GUARD ASSEM.....	1
6	7K1705	BAR.....	4
7	6K2451	BAR.....	1
8	S1595	BOLT.....	2

9	8S9092	BOLT.....	4
10	6K9538	GUARD ASSEM.....(Front)	1
11	6K9537	GUARD ASSEM.....	1
11	S1615	BOLT.....	8
12	3B4504	LOCKWASHER.....	8
13	S1592	BOLT.....	9
13	3B4510	LOCKWASHER.....	9
14	6K2446	GUARD ASSEM.....(Rear)	1
15	4B4281	WASHER.....	13
16	1A2519	WASHER.....	4

C INDICATES CHANGE

REF. NO.	PART NUMBER	DESCRIPTION	QTY
1	5509	BOLT	4
2	9M5205	PIN	2
3	2P775	SHROUD ASSEM.	1
4	7S7670	SUPPORT	1
5	3B4506	LOCKWASHER	10
6	4B4278	WASHER	8
7	3B4607	COITER PIN	2
8	8S2572	GROMMET	1
9	7S6559	RETAINER	1
10	51588	BOLT	2
11	3B4504	LOCKWASHER	6
12	9M5732	RIVET	6
13	51595	BOLT	11
14	3B4508	LOCKWASHER	11
15	8S7353	DOOR ASSEM.	1
16	8S6688	GUARD ASSEM.	1
17	8S7293	PLATE (Right Hand)	1
17	8S7294	PLATE (Left Hand)	1
18	2A762	BOLT	6
19	355734	HINGE	2
20	51594	BOLT	6
20	3B4510	LOCKWASHER	6
21	4B4281	WASHER	6
21	8S6687	PLATE	1
22	3P1276	PLATE ASSEM.	1
23	4B4280	WASHER	11
24	357837	BOLT	6
24	1B4208	NUT	6
25	3B4514	LOCKWASHER	6
25	T102	BOLT	4
26	355735	LUG	3
26	9S1366	BOLT	6
27	2M849	WASHER	6
28	9S5659	COLLAR	1
29	3P1263	COVER	1

142800

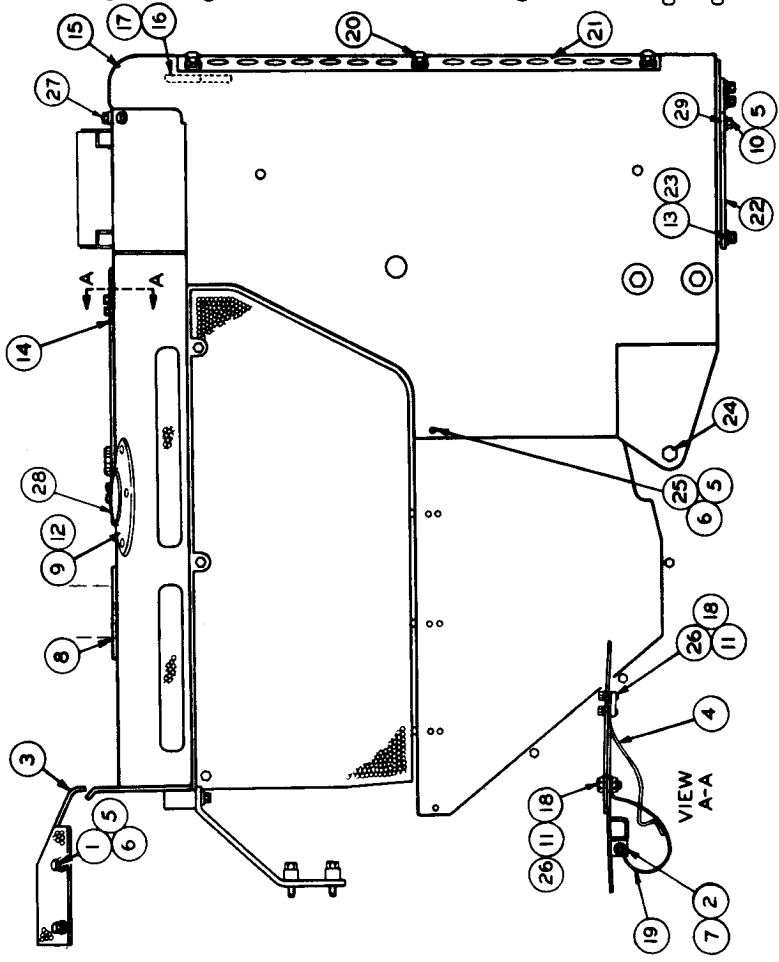

HOOD AND GUARD (2P1555 N/S)—Part 1

HOOD AND GUARD (2P1555 N/S)—Part 2

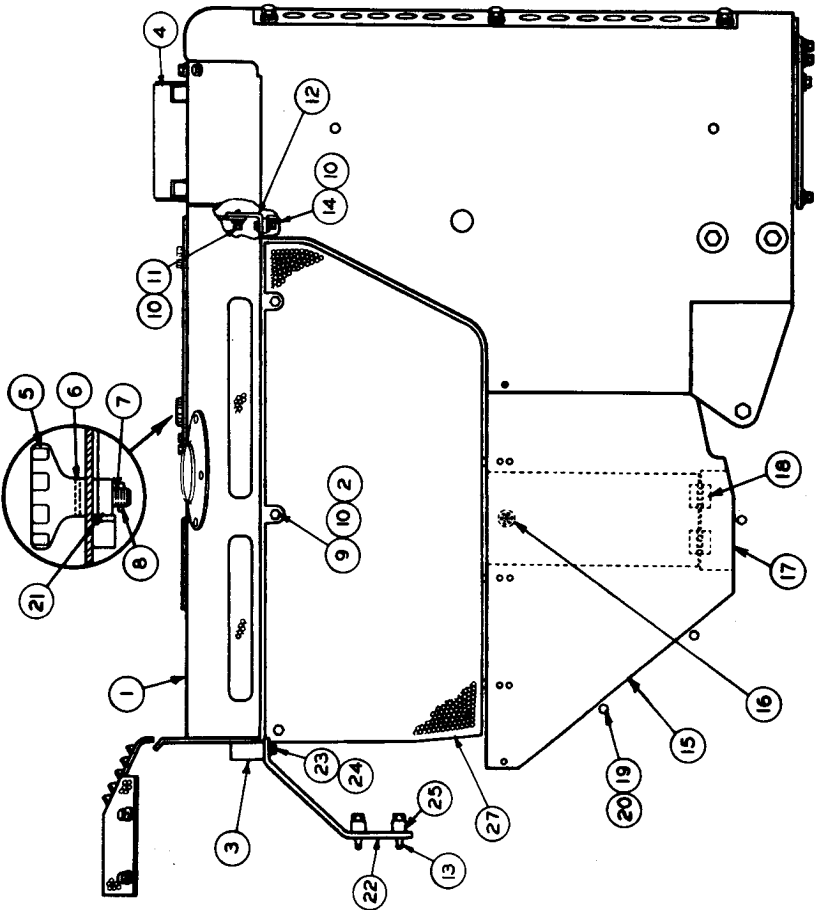

REF. NO.	PART NUMBER	DESCRIPTION	QTY
1	1P6286	HOOD ASSEM.	1
2	1F748	NUT	4
3	8S7969	BLOCK	2
4	1P3764	COVER ASSEM.	1
5	2M3881	LUG	1
6	7S2043	KNOB ASSEM.	1
7	2D4295	KNOB	1
8	3H6660	PIN	1
9	7S2042	STUD	1
10	4H1641	PIN	1
11	51621	BOLT	6
12	3B4508	LOCK WASHER	10
13	4B4280	WASHER	12
14	51621	BOLT	2
15	2P3097	BRACKET	2
16	2B947	BOLT	6
17	51587	BOLT	2
18	1D4719	NUT	2
19	9S8209	PLATE ASSEM. (R. H.)	1
20	9S8210	PLATE ASSEM. (L. H.)	1
21	51621	BOLT	1
22	3B4508	LOCK WASHER	1
23	4B4280	WASHER	1
24	2M473	LUG	1
25	8S3077	PLATE ASSEM.	1
26	9B2923	HINGE	2
27	51591	BOLT	6
28	3B4506	LOCK WASHER	6
29	3P5233	LATCH	1
30	8S7970	BRACKET	2
31	1A1460	BOLT	4
32	2M849	WASHER	4
33	7S3820	SPACER	4
34	8S1097	GUARD ASSEM. (R. H.)	6
35	8S1098	GUARD ASSEM. (L. H.)	1

C INDICATES CHANGE

162801

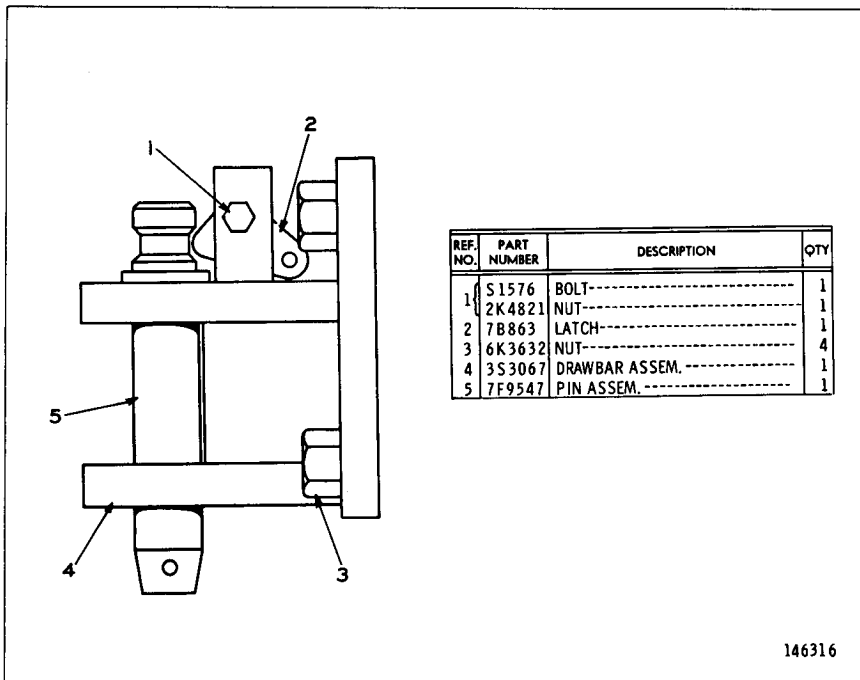

DRAWBAR (3S3397 N/S)

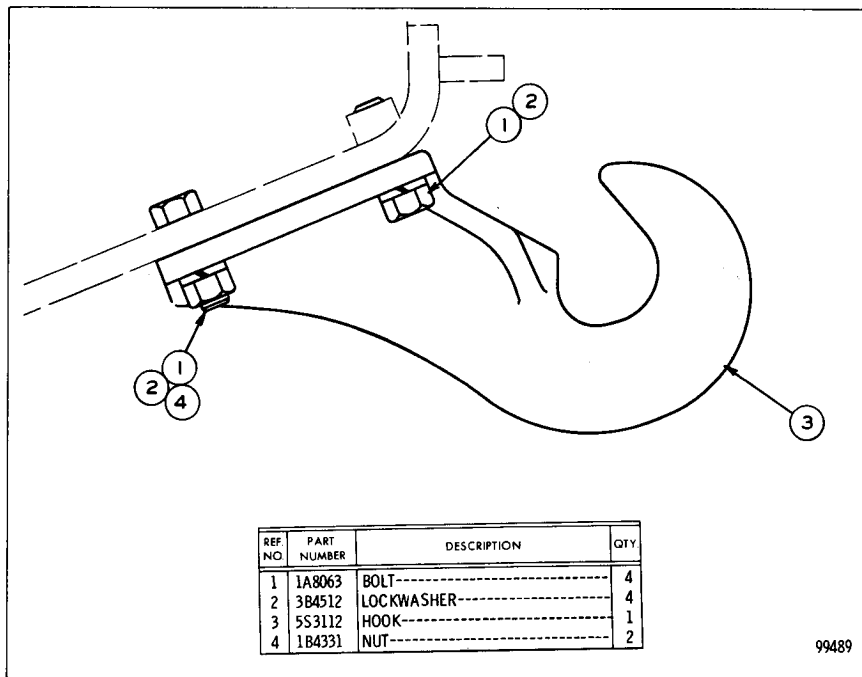

4S8076 FRONT PULL HOOK GROUP  
AN ATTACHMENT

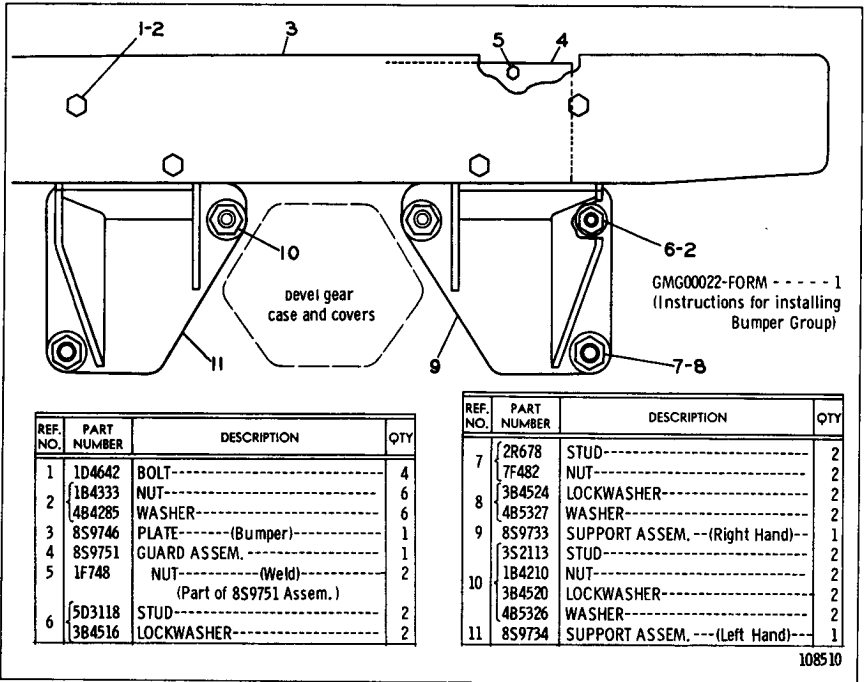

108510

8S9752 BUMPER GROUP  
AN ATTACHMENT

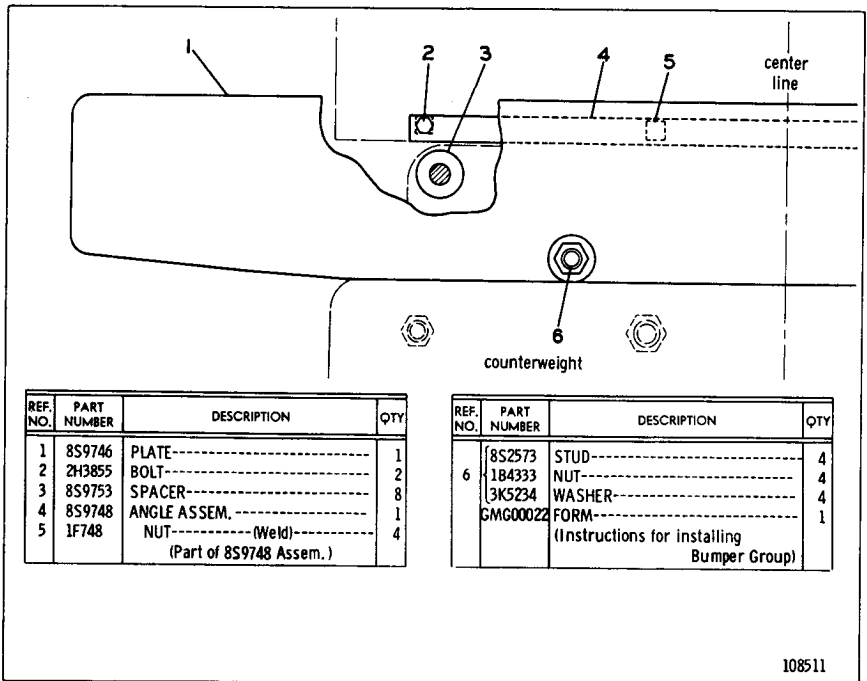

108511

8S9754 BUMPER GROUP  
FOR USE WITH 2000 POUND COUNTERWEIGHT  
AN ATTACHMENT

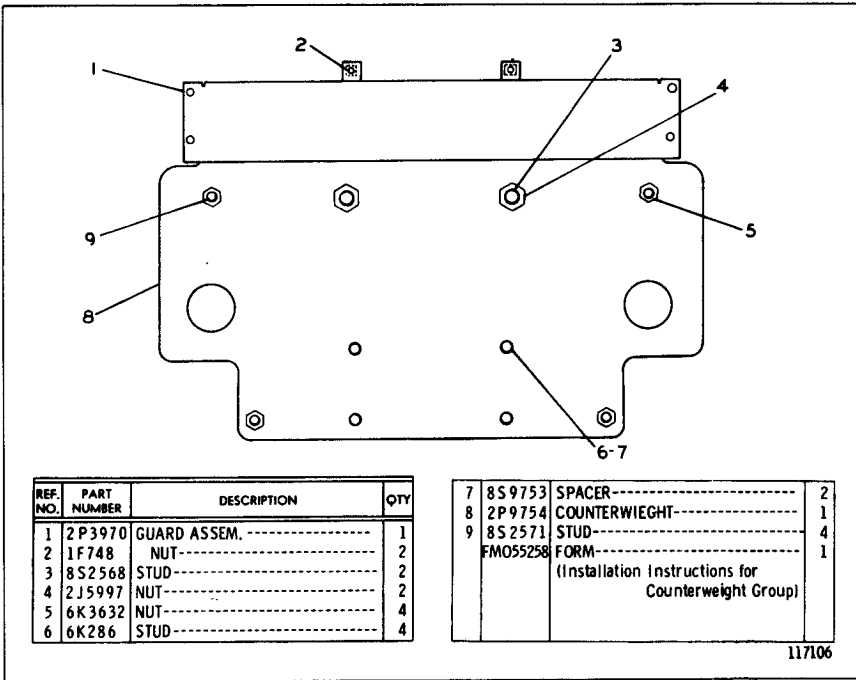

2P9759 COUNTERWEIGHT GROUP—1000 Pounds  
 FOR USE WITH 2P8538 OR 2P8965 MOUNTING  
 GROUPS SHOWN ON PAGES 246, 247 & 248. AN ATTACHMENT

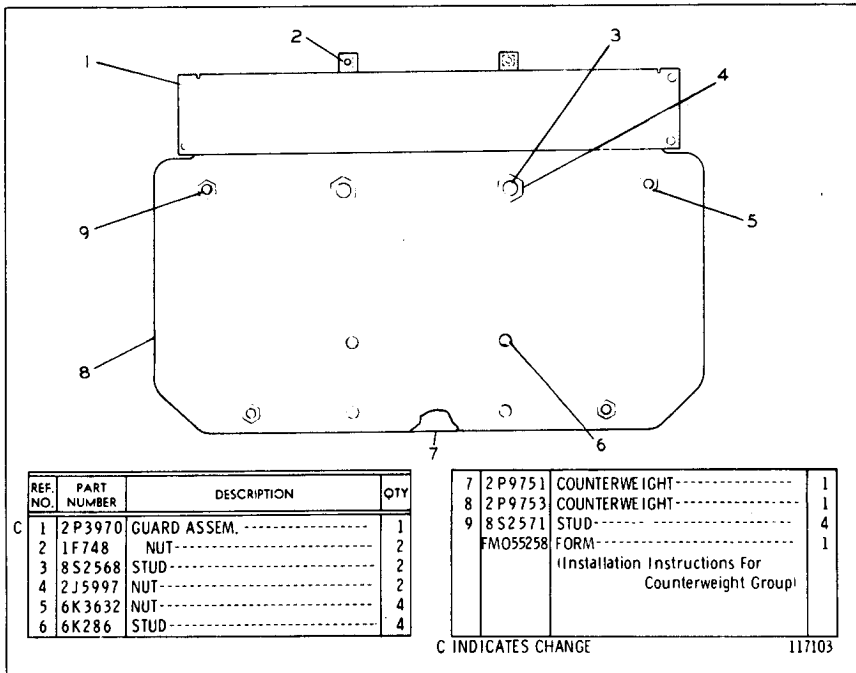

2P9755 COUNTERWEIGHT GROUP—2000 Pounds  
 AN ATTACHMENT

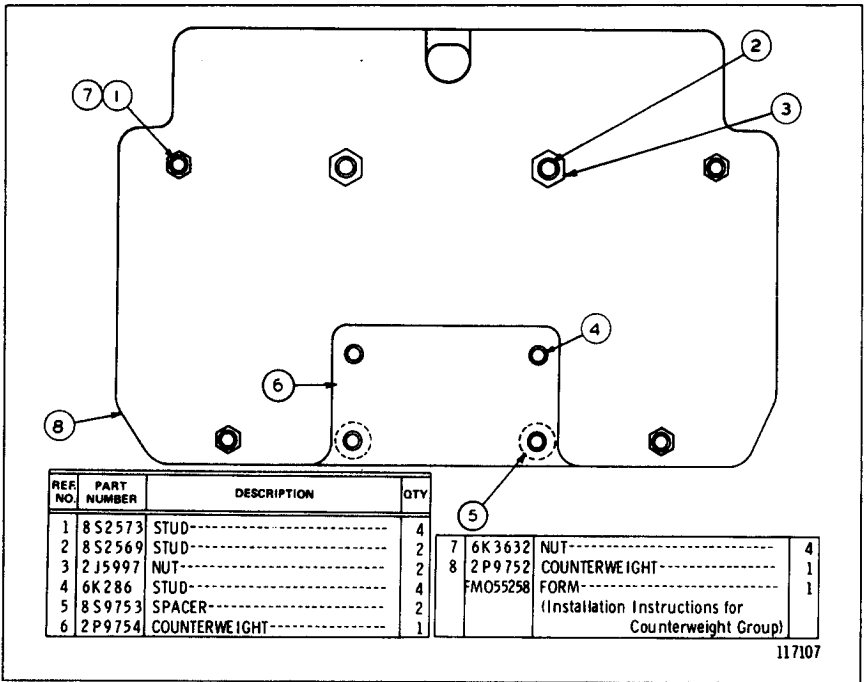

2P9760 COUNTERWEIGHT GROUP—2000 Pounds  
FOR USE WITH 2P8538 OR 2P8965 MOUNTING GROUPS SHOWN ON PAGES  
246, 247 & 248. AN ATTACHMENT

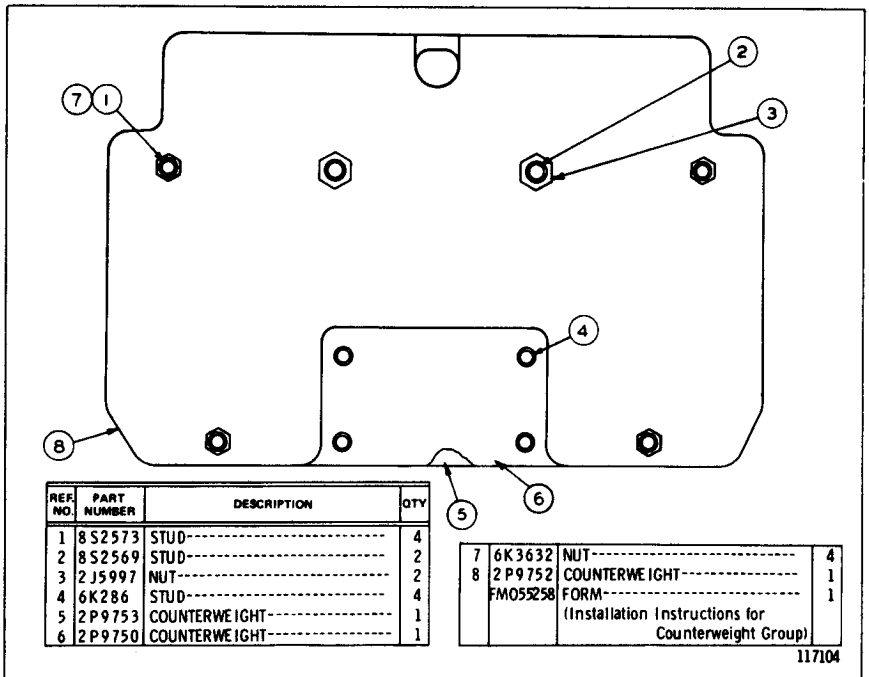

2P9756 COUNTERWEIGHT GROUP—3000 Pounds  
AN ATTACHMENT

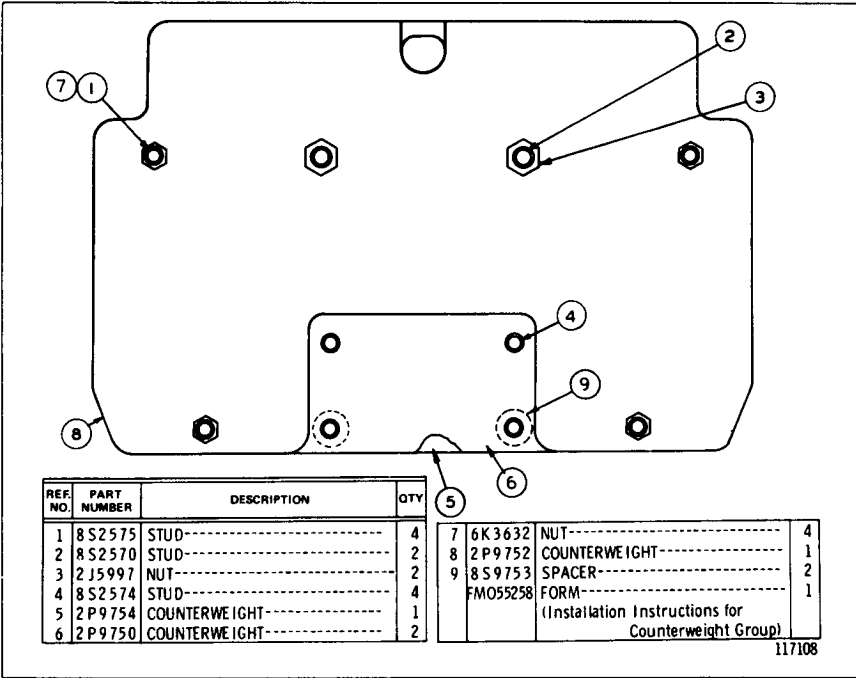

2P9761 COUNTERWEIGHT GROUP—3000 Pounds  
 FOR USE WITH 2P8538 OR 2P8965 MOUNTING GROUPS SHOWN ON PAGES  
 246, 247 & 248. AN ATTACHMENT

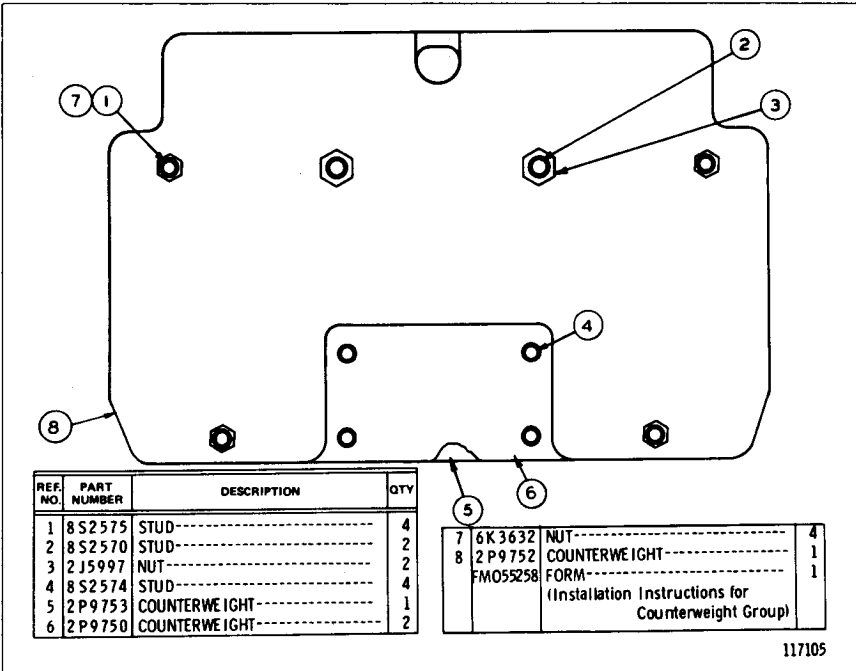

2P9757 COUNTERWEIGHT GROUP—4000 Pounds  
 AN ATTACHMENT



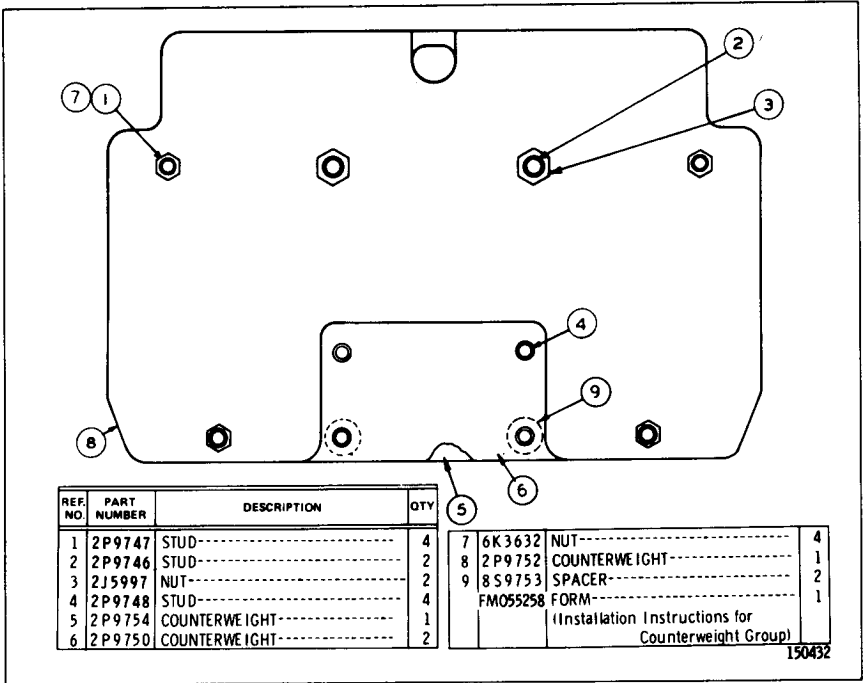

2P9762 COUNTERWEIGHT GROUP—4000 Pounds

Also part of 1V8152 Demolition Bucket Arrangement listed on Page 208A  
AN ATTACHMENT

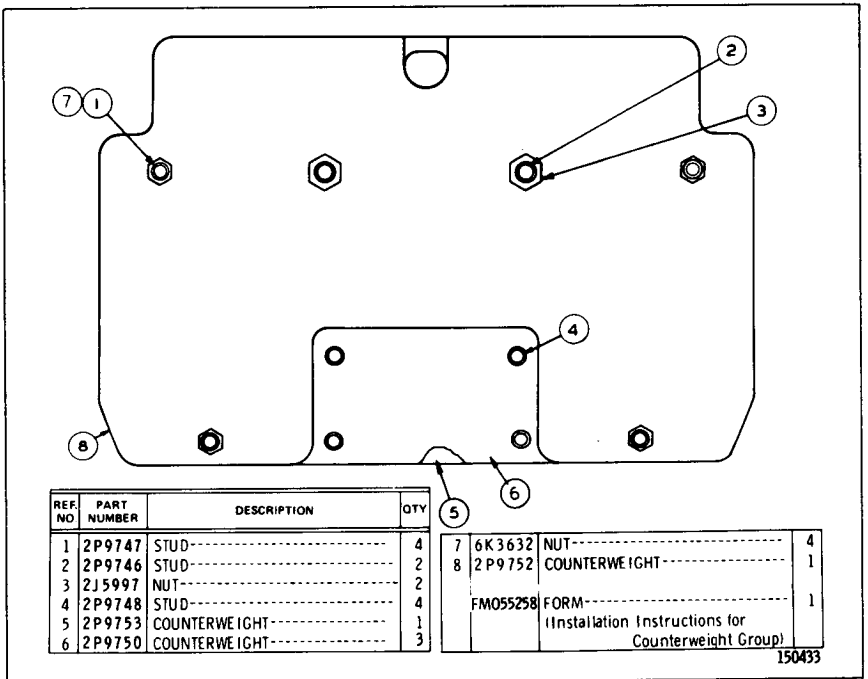

2P9758 COUNTERWEIGHT GROUP—5000 Pounds

Also part of 1V8153 Demolition Bucket Arrangement listed on Page 208A  
AN ATTACHMENT

8S9777	ARRANGEMENT		
	CONSISTS OF:		PAGE
1	6K5440	HYDRAULIC ARRANGEMENT.....	150
1	5S3270	TRAXCAVATOR ARRANGEMENT.....	103
1P9414	ARRANGEMENT		
	SERIAL NO. 11K5051 TO 11K5958 INCLUSIVE		
	CONSISTS OF:		
1	6K5440	HYDRAULIC ARRANGEMENT.....	150
1	1P9409	TRAXCAVATOR ARRANGEMENT.....	104

STEEL MILL TRAXCAVATOR ARRANGEMENTS—Factory Installation  
With Fire Resistant Fluid  
AN ATTACHMENT

	CONSISTS OF:		PAGE
1	5K6002	BUCKET CONTROL GROUP.....	200
4	2P3514	TRACK CARRIER ROLLER GROUP.....	117
2	5S1503	BAND & LINING ASSEMBLY.....	88
1	5S3272	TRACK ROLLER FRAME GROUP.....	111
1	5S3273	FRONT IDLER GROUP.....	108
1	8S6454	PRECLEANER ASSEMBLY.....	21
6	9S7284	TRACK ROLLER GROUP--SINGLE FLANGE.....	115
8	9S7386	TRACK ROLLER GROUP--DOUBLE FLANGE.....	115
1	2S7392	FILM--PRECLEANER INSTRUCTIONS	
14	9S2962	BOLT	
6	9S2963	BOLT	
20	9S2964	WASHER	
34	9S2965	WASHER	

5S3270 STEEL MILL TRAXCAVATOR ARRANGEMENT  
Part of 8S9777 Steel Mill Traxcayator Arrangement  
AN ATTACHMENT

CONSISTS OF:		PAGE
1	6K5440 HYDRAULIC ARRANGEMENT.....	150
1	3P1469 TRAXCAVATOR ARRANGEMENT.....	104A

3P1470 STEEL MILL TRAXCAVATOR ARRANGEMENT—Factory Installation  
Serial No. 11K5959—Up. With Fire Resistant Fluid. AN ATTACHMENT

		CONSISTS OF:	PAGE
1	5K6002	BUCKET CONTROL GROUP.....	200
1	1P5381	ENGINE FUNCTION WARNING GROUP.....	46
1	1P8853	FINAL DRIVE GUARD GROUP.....	82
1	2P1575	TRACK ROLLER FRAME GROUP.....	112
4	2P3514	TRACK CARRIER ROLLER GROUP.....	117
2	5S1503	BAND AND LINING ASSEMBLY.....	88
1	5S3273	FRONT IDLER GROUP.....	108
1	8S6454	PRECLEANER ASSEMBLY.....	21
1	3P1887	RADIATOR GUARD GROUP.....	17
6	9S7284	SINGLE FLANGE ROLLER GROUP.....	115
		SERIAL No. 11K1 TO 11K5680 INCLUSIVE	
	- OR -		
6	1P9400	SINGLE FLANGE ROLLER GROUP.....	115A
		SERIAL No. 11K5681 TO 11K5958 INCLUSIVE	
8	9S7386	DOUBLE FLANGE ROLLER GROUP.....	115
		SERIAL No. 11K1 TO 11K5680 INCLUSIVE	
	- OR -		
8	1P9402	DOUBLE FLANGE ROLLER GROUP.....	115B
		SERIAL No. 11K5681 TO 11K5958 INCLUSIVE	
1	2H3934	SEAL	
1	2P7980	HOOD ASSEMBLY	
		CONSISTS OF:	
	4	1F748 NUT	
	1	2M3881 LUG	
	1	1P3764 COVER ASSEMBLY	
	2	8S7969 BLOCK	
	1	2P8968 CAP ASSEMBLY	
	1	2P8970 BAFFLE ASSEMBLY	
	1	3P415 PLUNGER	
	1	3P416 TANK ASSEMBLY	
		CONSISTS OF:	
	1	8H3496 FITTING	
	1	1L5784 FITTING	
	1	7M5007 FITTING	
1	2S7392	FILM--PRECLEANER INSTRUCTIONS	
126"	4S8456	TUBE--COPPER--ORDER BY THE FOOT	
14	9S2962	BOLT	
6	9S2963	BOLT	
20	9S2964	WASHER	
34	9S2965	WASHER	
1	9S1936	BUSHING ASSEMBLY--ENGINE SUPPORT	

## 1P9409 STEEL MILL TRAXCAVATOR ARRANGEMENT

Serial No. 11K5051 to 11K5958 inclusive

Part of 1P9414 Steel Mill Traxcavator Arrangement listed on Page 103

		CONSISTS OF:	PAGE
1	5K6002	BUCKET CONTROL GROUP.....	200
1	1P5381	ENGINE FUNCTION WARNING GROUP.....	46
1	1P8853	FINAL DRIVE GUARD GROUP.....	82
4	2P3514	TRACK CARRIER ROLLER GROUP.....	117
1	2P8943	TRUNNION GROUP.....	28
6	3P1520	SINGLE FLANGE ROLLER GROUP.....	115C
8	3P1521	DOUBLE FLANGE ROLLER GROUP.....	115D
1	3P1887	RADIATOR GUARD GROUP.....	17
1	3P1495	FRONT IDLER GROUP.....	108B
2	5S1503	BAND AND LINING ASSEMBLY.....	88
1	8S6454	PRECLEANER ASSEMBLY.....	21
1	2H3934	SEAL	
1	2P7980	HOOD ASSEMBLY	
CONSISTS OF:			
	4	1F748 NUT	
	1	2M3881 LUG	
	1	1P3764 COVER ASSEMBLY	
	2	8S7969 BLOCK	
1	2P8968	CAP ASSEMBLY	
1	2P8970	BAFFLE ASSEMBLY	
1	3P415	PLUNGER	
1	3P416	TANK ASSEMBLY	
CONSISTS OF:			
	1	8H3496 FITTING	
	1	1L5784 FITTING	
	1	7M5007 FITTING	
1	2S7392	FILM--PRECLEANER INSTRUCTIONS	
126"	4S8384	TUBE--COPPER--ORDER BY THE FOOT	
14	9S2962	BOLT	
6	9S2963	BOLT	
20	9S2964	WASHER	
34	9S2965	WASHER	

3P1469 STEEL MILL TRAXCAVATOR ARRANGEMENT—Factory Installation  
 Serial No. 11K5959—Up. Part of 3P1470 Steel Mill Traxcavator  
 Arrangement listed on Page 103B. AN ATTACHMENT

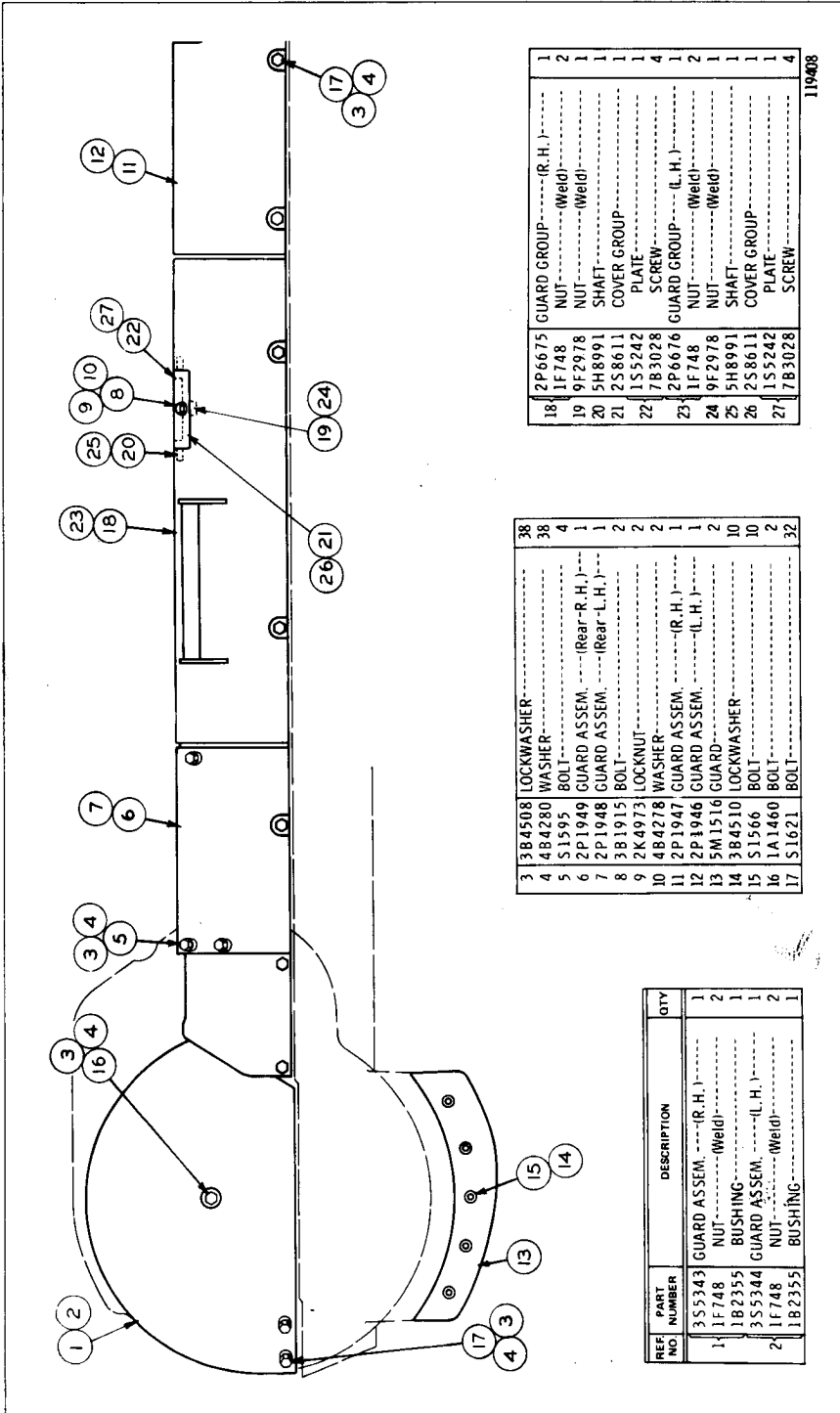

REF NO.	PART NUMBER	DESCRIPTION	QTY
	3S5343	GUARD ASSEM---(R.H.)	1
1	1F748	NUT---(Weld)	2
	1B2355	BUSHING	1
	3S5344	GUARD ASSEM---(L.H.)	1
2	1F748	NUT---(Weld)	2
	1B2355	BUSHING	1

3	3B4508	LOCKWASHER	38
4	4B4280	WASHER	38
5	5S1595	BOLT	4
6	2P1949	GUARD ASSEM---(Rear-R.H.)	1
7	2P1948	GUARD ASSEM---(Rear-L.H.)	1
8	3B1915	BOLT	2
9	2K4973	LOCKNUT	2
10	4B4278	WASHER	2
11	2P1947	GUARD ASSEM---(R.H.)	1
12	2P1946	GUARD ASSEM---(L.H.)	1
13	5M1516	GUARD	2
14	3B4510	LOCKWASHER	10
15	5S1566	BOLT	10
16	1A1460	BOLT	2
17	5S1621	BOLT	32

18	2P6675	GUARD GROUP---(R.H.)	1
	1F748	NUT---(Weld)	2
	9F2978	SHAFT	1
	5H8991	COVER GROUP	1
	2S8611	PLATE	1
	1S5242	SCREW	4
	7B3028	GUARD GROUP---(L.H.)	1
	2P6676	NUT---(Weld)	2
	1F748	SHAFT	1
	9F2978	COVER GROUP	1
	5H8991	PLATE	1
	2S8611	SCREW	1
	1S5242	SCREW	1
	7B3028	SCREW	4

119408

RECOIL MECHANISM GUARD (2P2056 N/S)

Serial No. 11K5051 to 11K5958 inclusive

NOTE: QUANTITIES SHOWN ARE THOSE REQUIRED FOR BOTH R.H. AND L.H. SIDES

RECOIL MECHANISM GUARD (3P1493 N/S)  
Serial No. 11K5959—Up

NOTE: QUANTITIES SHOWN ARE THOSE REQUIRED FOR BOTH R.H. AND L.H. SIDES

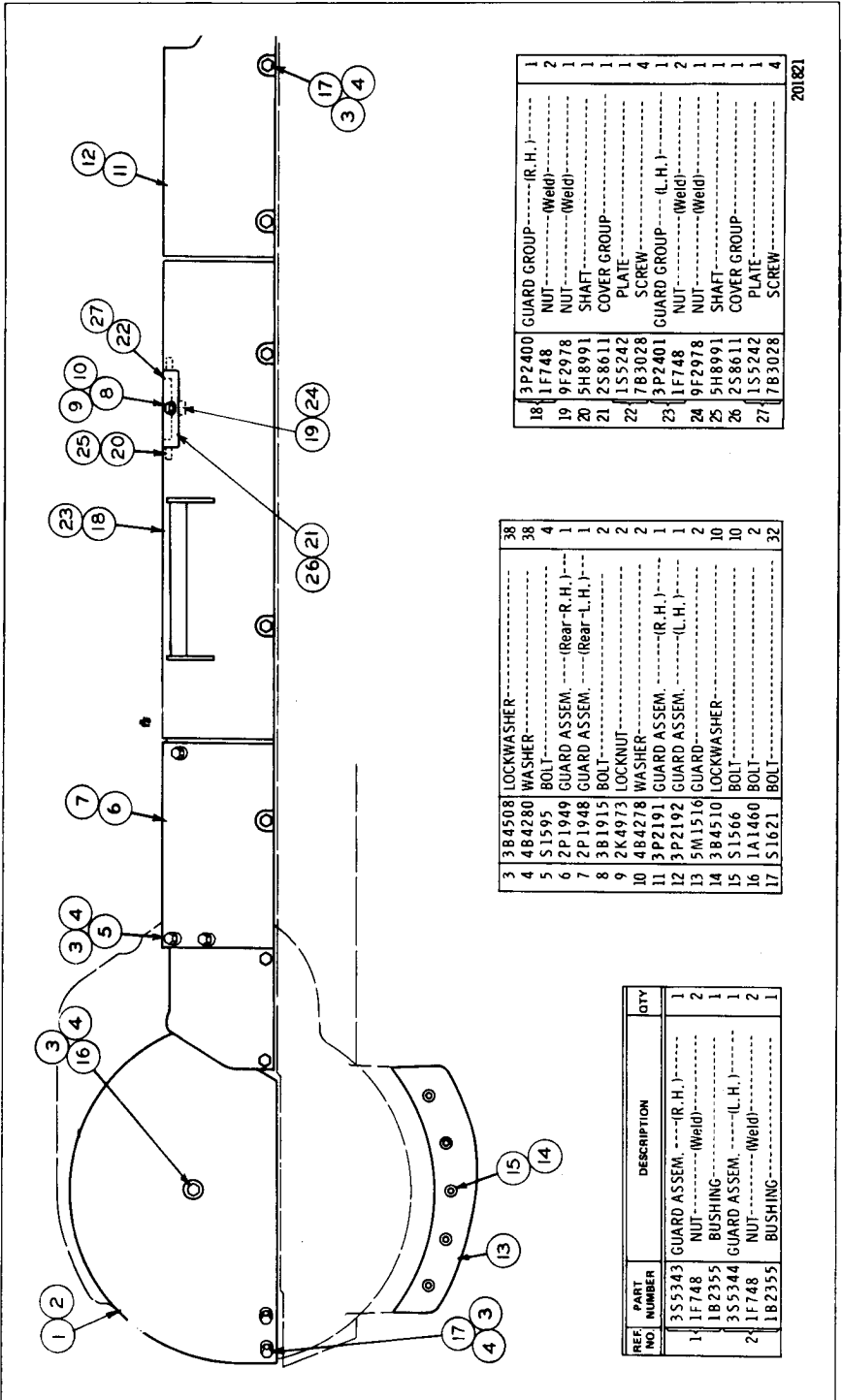

18	3P2400	GUARD GROUP---(R. H.)---	1
19	1F748	NUT---(Weld)---	2
20	9F2978	NUT---(Weld)---	1
21	5H8991	SHAFT	1
22	2S8611	COVER GROUP	1
23	1S5242	PLATE	4
24	7B3028	SCREW---	1
25	3P2401	GUARD GROUP---(L. H.)---	4
26	1F748	NUT---(Weld)---	2
27	9F2978	NUT---(Weld)---	1
28	5H8991	SHAFT	1
29	2S8611	COVER GROUP	1
30	1S5242	PLATE	1
31	7B3028	SCREW---	4

3	84508	LOCKWASHER	38
4	484280	WASHER	4
5	S1595	BOLT	1
6	2P1949	GUARD ASSEM.---(Rear-R. H.)---	1
7	2P1948	GUARD ASSEM.---(Rear-L. H.)---	1
8	3B1915	BOLT	2
9	2K4973	LOCKNUT	2
10	484278	WASHER	2
11	3P2191	GUARD ASSEM.---(R. H.)---	1
12	3P2192	GUARD ASSEM.---(L. H.)---	1
13	5M1516	GUARD	2
14	3B4510	LOCKWASHER	10
15	S1566	BOLT	10
16	1A1460	BOLT	2
17	S1621	BOLT	32

REF. NO.	PART NUMBER	DESCRIPTION	QTY
1	355343	GUARD ASSEM.---(R. H.)---	1
1	1F748	NUT---(Weld)---	2
1	1B2355	BUSHING	1
1	355344	GUARD ASSEM.---(L. H.)---	1
2	1F748	NUT---(Weld)---	2
1	1B2355	BUSHING	1

201821

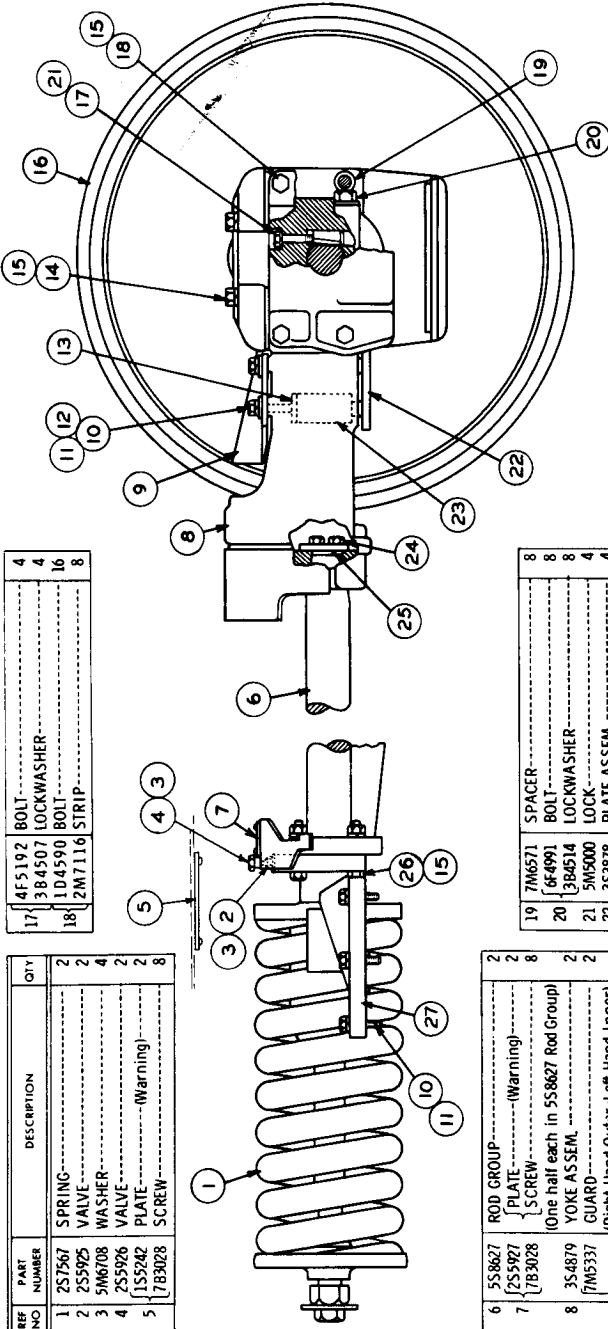

REF NO.	PART NUMBER	DESCRIPTION	QTY
17	4F5192	BOLT	4
18	3B4507	LOCKWASHER	4
19	1D4590	BOLT	16
20	2M7116	STRIP	8

REF NO.	PART NUMBER	DESCRIPTION	QTY
1	257567	SPRING	2
2	255925	VALVE	2
3	5M6708	WASHER	4
4	255926	VALVE	2
5	1S5242	PLATE	2
	783028	SCREW	8

REF NO.	PART NUMBER	DESCRIPTION	QTY
6	5S8627	ROD GROUP	2
7	255927	PLATE	2
	783028	SCREW	8
8	354879	YOKE ASSEM.	2
9	7M5337	GUARD	2
		(Right Hand Outer-Left Hand Inner)	
		(Right Hand Outer-Left Hand Inner)	
10	1A1460	BOLT	20
11	3B4508	LOCKWASHER	20
12	7F502	WASHER	8
13	4B1398	PLATE	8
14	1B4367	BOLT	8
15	3B4510	LOCKWASHER	32
16	158186	IDLER ASSEM.	2

REF NO.	PART NUMBER	DESCRIPTION	QTY
19	7M6571	SPACER	8
20	6F4991	BOLT	8
21	3B4514	LOCKWASHER	8
22	5M5000	LOCK	4
23	353878	PLATE ASSEM.	4
24	4F5003	SPRING ASSEM.	8
25	8M9478	BOLT	4
26	1A8537	BOLT	2
	1D4720	NUT	8
	255967	STOP	2
		(Right Hand Outer-Left Hand Inner)	
27	255968	STOP	2
		(Right Hand Inner-Left Hand Outer)	

119190

NOTE: QUANTITIES SHOWN ARE THOSE REQUIRED FOR BOTH RIGHT AND LEFT HAND SIDES

FRONT IDLER (3S2026 N/S)—Part 1  
 Serial No. 11K5051 to 11K5968 inclusive  
 Note: 1P1950 Idler Group (Reinforced), consisting of: 2—9S7462 Idler Assembly, is available



FRONT IDLER (3S2026 N/S)—Part 2  
Serial No. 11K5051 to 11K5958 inclusive

NOTE: QUANTITIES SHOWN ARE THOSE REQUIRED FOR BOTH RIGHT AND LEFT HAND SIDES

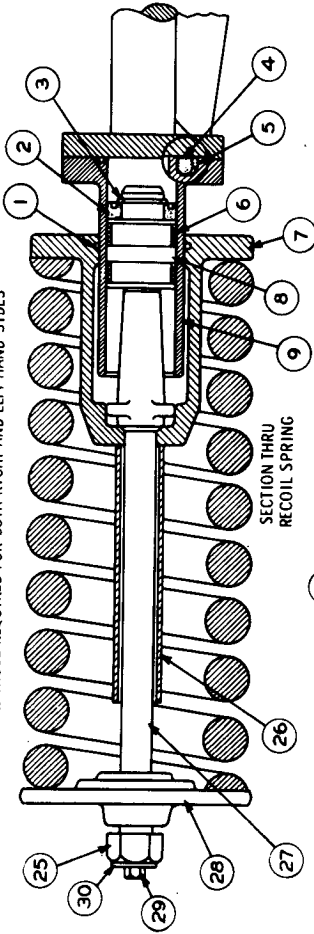

SECTION THRU RECOIL SPRING

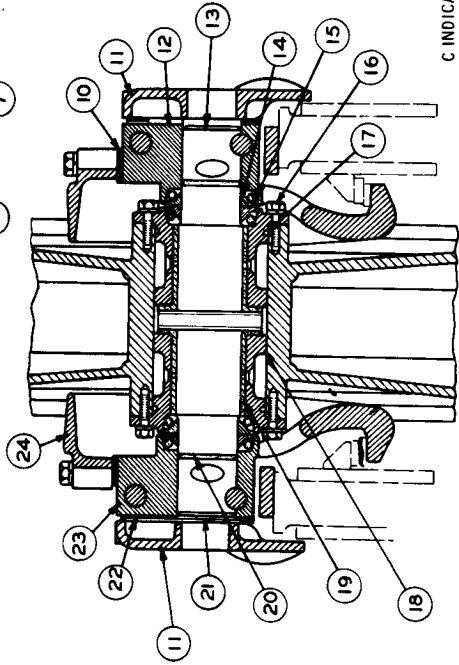

SECTION THRU FRONT IDLER

C INDICATES CHANGE

REF NO	PART NUMBER	DESCRIPTION	QTY
1	15F149	SEAL	2
2	4S9006	SEAL	2
3	1H8397	RING	2
4	5M2997	SEAL	2
5	5M2998	RING	2
6	6H6269	RING	4
7	15816	PILOT ASSEM.	2
8	8H7980	PISTON	2
9	155331	CYLINDER	2
10	2M3514	SHIM	12
11	195359	PLATE	4
12	9M9760	BEARING	2
13	9M9758	(Right Hand Inner-Left Hand Outer) SHAFT	2
14	1M8747	SEAL GROUP	4
15	8H2262	RING	2
16	3B1915	BOLT	24
17	3B4506	LOCKWASHER	24
18	4H9105	SEAL	4
19	259451	BUSHING ASSEM.	4
20	9B2289	PLUG	4
21	852539	BEARING	1
22	8F6711	SEAL	2
23	2P347	PLUG	4
24	1S8947	SEAL	2
25	1P7659	SHIM	48
26	9M9759	BEARING	2
27	3P6060	(Right Hand Outer-Left Hand Inner) COLLAR ASSEM.	4
28	9M3770	NUT	2
29	8M6191	SLEEVE	2
30	15814	BOLT	2
31	2M369	PILOT	2
32	51620	BOLT	2
33	2S1654	WASHER	2

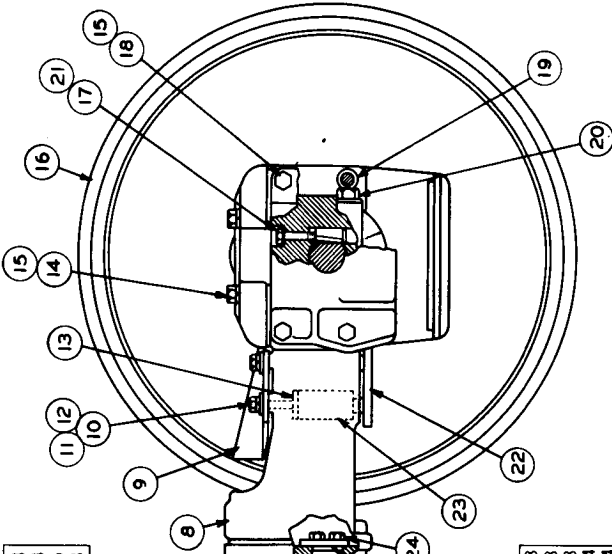

17	4F5192	BOLT	4
4	3B4507	LOCKWASHER	4
16	1D4590	BOLT	16
8	2M7116	STRIP	8

REF NO	PART NUMBER	DESCRIPTION	QTY
1	3P1885	SPRING	2
2	2S5925	VALVE	2
3	5M6708	WASHER	4
4	2S5926	VALVE	2
5	1S5242	PLATE	2
		---(Warning)---	
	7B3028	SCREW	8

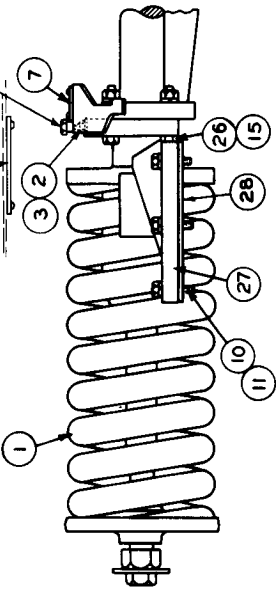

REF NO	PART NUMBER	DESCRIPTION	QTY
6	3P2250	ROD GROUP	2
		(Each Includes)	
7	2S5927	PLATE	1
		---(Warning)---	
7	7B3028	SCREW	4
8	3P2305	YOKE ASSEM	2
	7M6537	GUARD	2
		(R. H. Outer-L. H. Inner)	
9	7M6538	GUARD	2
		(R. H. Inner-L. H. Outer)	
10	1A1460	BOLT	20
11	3B4508	LOCKWASHER	20
12	7F502	WASHER	8
13	4B1398	PLATE	8
14	1B4367	BOLT	8
15	3B4510	LOCKWASHER	8
16	1S8186	IDLER ASSEM	2

19	7M6571	SPACER	8
8	6F4991	BOLT	8
20	3B4514	LOCKWASHER	8
4	215M5000	LOCK	4
4	223S3878	PLATE ASSEM	4
8	234F5003	SPRING ASSEM	8
4	247B3235	BOLT	4
2	8M9478	WASHER	2
8	1A8537	BOLT	8
8	1D4720	NUT	8
2	2S5967	STOP--(R. H. Outer-L. H. Inner)--	2
2	2S5968	STOP--(R. H. Inner-L. H. Outer)--	2
4	6P4417	BAR	4

C INDICATES CHANGE  
 NOTE: QUANTITIES SHOWN ARE THOSE REQUIRED  
 FOR BOTH RIGHT AND LEFT HAND SIDES

150625

FRONT IDLER (3P1496 N/S)—Part 1  
 Serial No. 11K5959—Up

FRONT IDLER (3P1496 N/S)—Part 2  
Serial No. 11K5959—Up

NOTE: QUANTITIES SHOWN ARE THOSE REQUIRED FOR BOTH RIGHT AND LEFT HAND SIDES

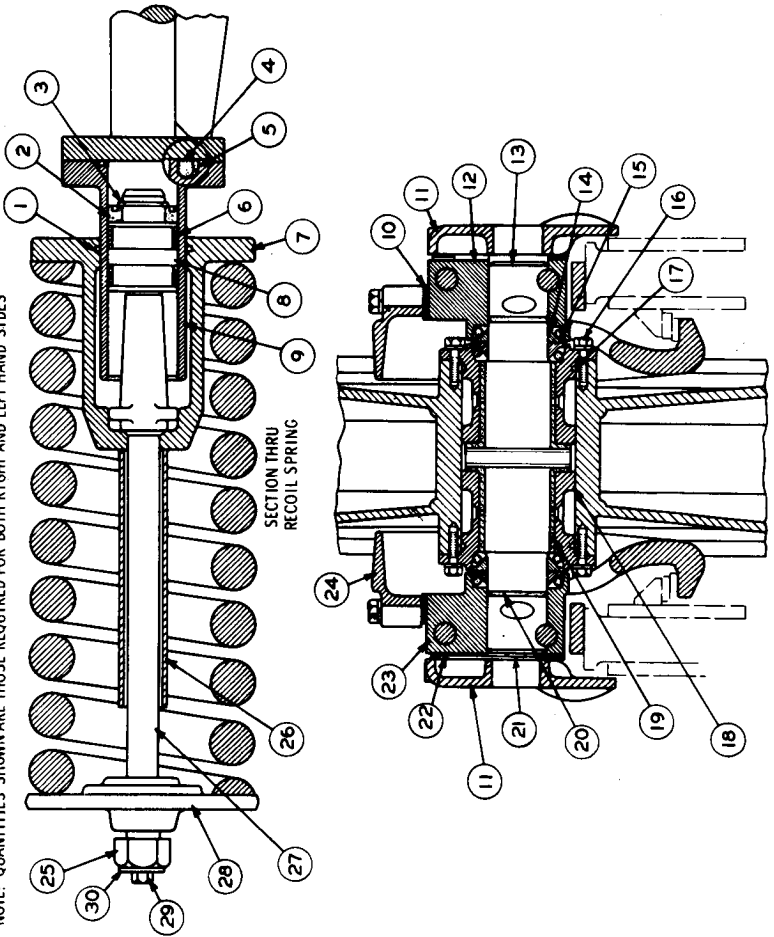

REF. NO.	PART NUMBER	DESCRIPTION	QTY.
1	5F149	SEAL	2
2	4S9006	SEAL	2
3	1H8397	RING	2
4	5M2997	SEAL	2
5	5M2998	RING	2
6	6H6269	RING	4
7	1S816	PILOT ASSEM.	2
8	8H7980	PISTON	2
9	1S5331	CYLINDER	2
10	2M3514	SHIM	12
11	3P9989	PLATE	4
12	9M9760	BEARING	2
13	9M9758	SHAFT (Right Hand Inner-Left Hand Outer)	2
14	1M8747	SEAL GROUP	4
15	8H2262	RING	2
16	3B1915	BOLT	24
17	3B4506	LOCKWASHER	24
18	9M9729	SEAL	4
19	3P8432	BUSHING ASSEM.	4
20	9B2289	PIN	2
21	8S2539	BEARING	1
22	8M4390	SEAL	4
23	12P347	PLUG	2
24	12P2975	SEAL	2
25	1P7659	SHIM	48
26	9M9759	BEARING	2
27	3P6060	(Right Hand Outer-Left Hand Inner) COLLAR ASSEM.	4
28	9M3770	NUT	2
29	3P2196	SLEEVE	2
30	3P2198	BOLT	2
31	2M3669	PILOT	2
32	51620	BOLT	2
33	2S1654	WASHER	2

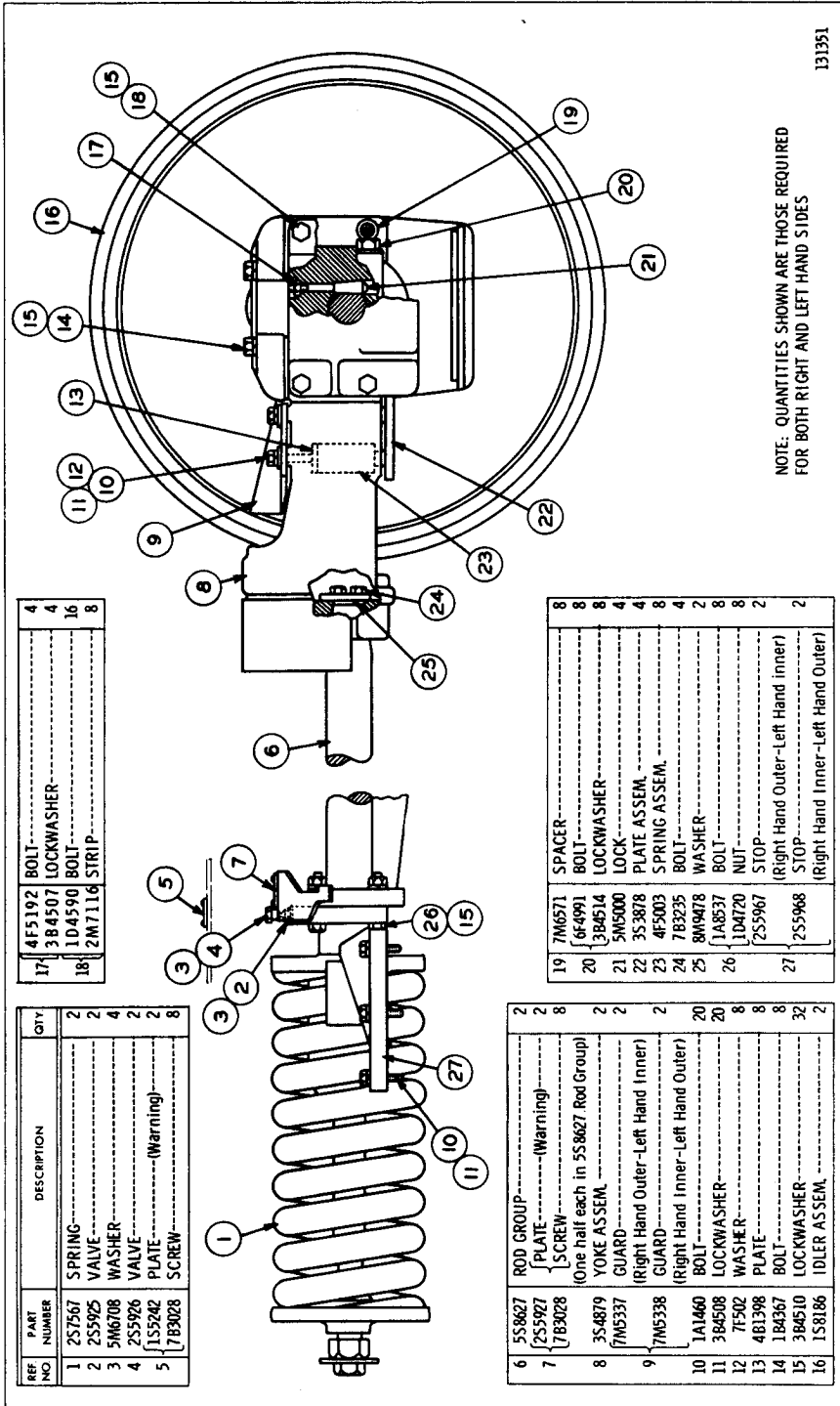

NOTE: QUANTITIES SHOWN ARE THOSE REQUIRED FOR BOTH RIGHT AND LEFT HAND SIDES

131351

17	4F5192 BOLT	4
18	3B4507 LOCKWASHER	4
	1D4590 BOLT	16
	2M7116 STRIP	8

REF NO	PART NUMBER	DESCRIPTION	QTY
1	257567	SPRING	2
2	255925	VALVE	2
3	5M6708	WASHER	4
4	255926	VALVE	2
5	1S5242	PLATE (Warning)	2
	7B3028	SCREW	8

19	7M0571	SPACER	8
20	664991	BOLT	8
	3B4514	LOCKWASHER	8
21	5M5000	LOCK	4
22	353878	PLATE ASSEM.	4
23	4F5003	SPRING ASSEM.	8
24	7B3235	BOLT	4
25	8M9478	WASHER	2
26	1A8537	BOLT	8
	1D4720	NUT	8
	255967	STOP (Right Hand Outer-Left Hand Inner)	2
27	255968	STOP (Right Hand Inner-Left Hand Outer)	2

6	5S8627	ROD GROUP	2
7	255927	PLATE (Warning)	2
	7B3028	SCREW	8
8	354879	YOKE ASSEM. (One half each in 5S8627 Rod Group)	2
	7M5337	GUARD (Right Hand Outer-Left Hand Inner)	2
9	7M5338	GUARD (Right Hand Inner-Left Hand Outer)	2
10	1A1460	BOLT	20
11	3B4508	LOCKWASHER	20
12	7F502	WASHER	8
13	4B1398	PLATE	8
14	1B4367	BOLT	8
15	3B4510	LOCKWASHER	32
16	1S8186	IDLER ASSEM.	2

5S3273 FRONT IDLER—Part 1  
 Part of 5S3270 and 1P9409 Steel Mill Traxcavator Arrangements listed on Pages 103 and 104  
 AN ATTACHMENT

5S3273 FRONT IDLER—Part 2  
 Part of 5S3270 and 1P9409 Steel Mill Traxcavator Arrangement listed on Pages 103 and 104  
 AN ATTACHMENT

NOTE: QUANTITIES SHOWN ARE THOSE REQUIRED FOR BOTH RIGHT AND LEFT HAND SIDES

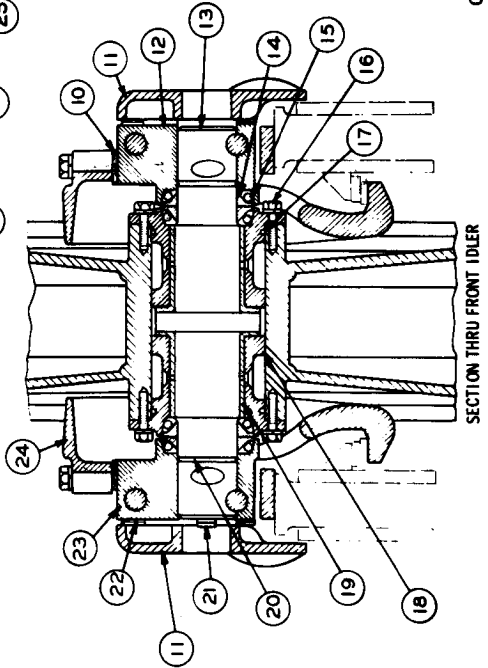
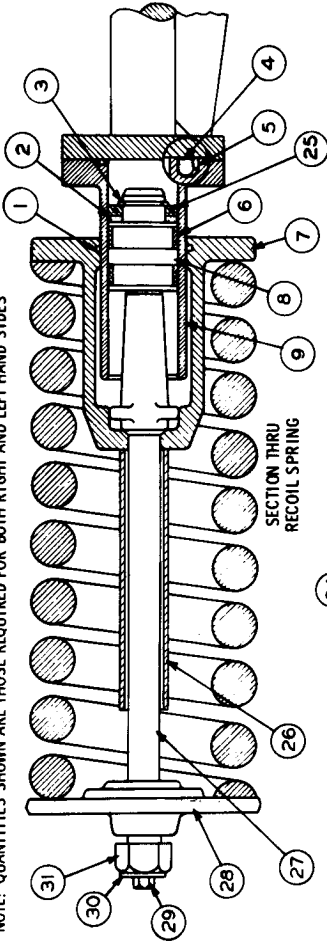

REF NO.	PART NUMBER	DESCRIPTION	QTY
1	5F149	SEAL	2
2	8H5498	WASHER	2
3	1H8397	RING	2
4	5M2997	SEAL	2
5	5M2998	RING	2
6	6H6269	RING	4
7	1S816	PILOT ASSEM.	2
8	8H7980	PISTON	2
9	1S5331	CYLINDER	2
10	2M3514	SHIM	12
11	9S3509	PLATE	4
12	9M9760	BEARING	2
13	9M9758	(Right Hand Inner-Left Hand Outer) SHAFT (idler)	2
14	4S8984	SEAL GROUP	4
15	9M9730	RING	4
16	3B1915	BOLT	24
17	3B4506	LOCKWASHER	24
18	2S9451	BUSHING ASSEM.	2
19	9B2289	PIN	2
20	8S2539	BEARING	1
21	8M4390	SEAL	4
22	2P347	PLUG	2
23	2P2975	SEAL	2
24	1P7659	SHIM	48
25	9M9759	BEARING	2
26	3P6060	IR. H. Outer- L. H. Inner) COLLAR ASSEM.	4
27	3P6059	STRIP	1
28	4S9061	PACKING	2
29	8M6191	SLEEVE	2
30	1S814	BOLT	2
31	2M369	PILOT	2
32	2M1620	BOLT	2
33	2S1654	WASHER	2
34	9M3770	NUT	2

C INDICATES CHANGE

146931

150524

REF NO.	PART NUMBER	DESCRIPTION	QTY
17	4F5192	BOLT	4
18	3B4507	LOCKWASHER	4
	104590	BOLT	16
	2M7116	STRIP	8

REF NO.	PART NUMBER	DESCRIPTION	QTY
1	3P1885	SPRING	2
2	2S5925	VALVE	2
3	3M6708	WASHER	4
4	2S5926	VALVE	2
5	1S5242	PLATE	2
	7B3028	SCREW	8

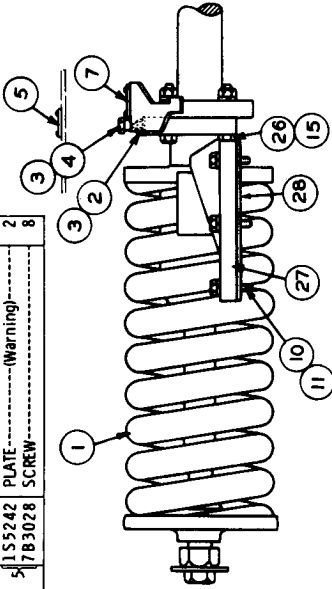

REF NO.	PART NUMBER	DESCRIPTION	QTY
6	3P2250	ROD GROUP	2
7	2S5927	(Each Includes)	1
	7B3028	PLATE	4
		SCREW	4
8	3P2305	YOKE ASSEM.	2
9	7M5337	GUARD	2
		(IR. H. -Outer-L. H. Inner)	
	7M5338	GUARD	2
		(IR. H. Inner-L. H. Outer)	
10	1A1460	BOLT	20
11	3B4508	LOCKWASHER	20
12	7F502	WASHER	8
13	4B1398	PLATE	8
14	1B4367	BOLT	8
15	3B4510	LOCKWASHER	32
16	1S8186	IDLER ASSEM.	2

19	7M6571	SPACER	8
20	6F4991	BOLT	8
	3B4514	LOCKWASHER	8
21	5M5000	LOCK	4
22	3S3878	PLATE ASSEM.	4
23	4F5003	SPRING ASSEM.	4
24	7B3235	BOLT	4
25	8M9478	WASHER	2
26	1A8537	BOLT	8
	1D4720	NUT	8
27	2S5967	STOP--(R. H. Outer-L. H. Inner)	2
	2S5968	STOP--(R. H. Inner-L. H. Outer)	2
28	6P4417	BAR	4

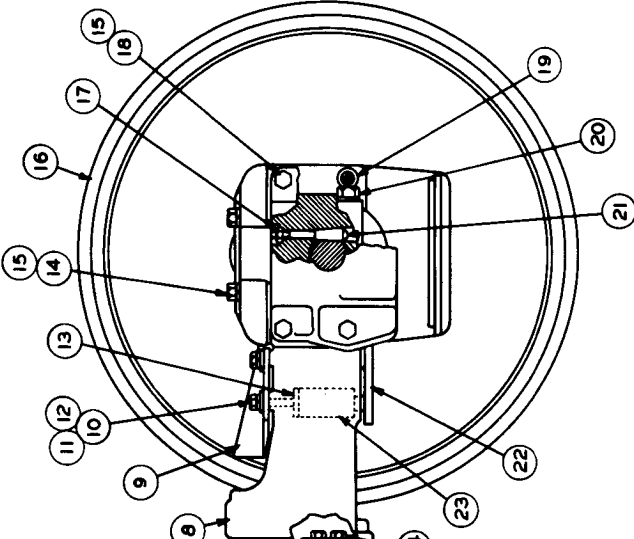

C INDICATES CHANGE  
NOTE: QUANTITIES SHOWN ARE THOSE REQUIRED  
FOR BOTH RIGHT AND LEFT HAND SIDES

3P1495 FRONT IDLER GROUP—Part 1  
Serial No. 11K5959—Up  
Part of 3P1469 Steel Mill Traxcavator Arrangement listed on Page 104A  
AN ATTACHMENT

3P1495 FRONT IDLER GROUP—Part 2

Serial No. 11K9969—Up

Part of 3P1469 Steel Mill Traxcavator Arrangement listed on Page 104A  
AN ATTACHMENT

NOTE: QUANTITIES SHOWN ARE THOSE REQUIRED FOR BOTH RIGHT AND LEFT HAND SIDES

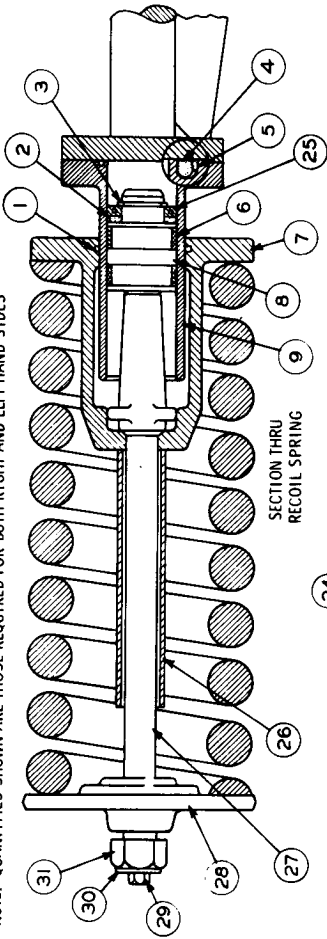

SECTION THRU RECOIL SPRING

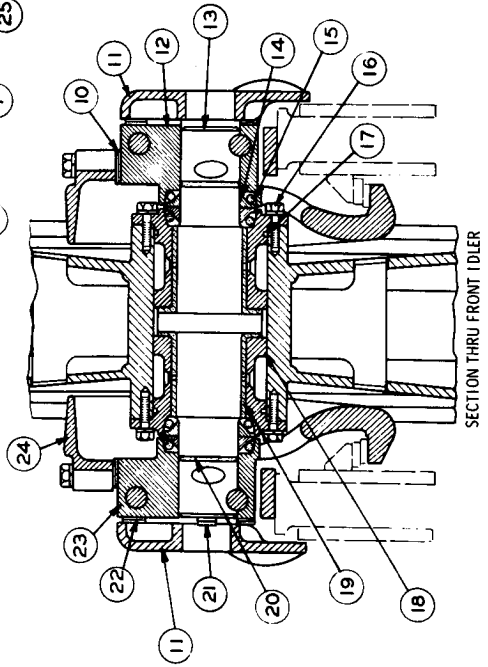

SECTION THRU FRONT IDLER

REF. NO.	PART NUMBER	DESCRIPTION	QTY
1	5F149	SEAL	2
2	8H5498	WASHER	2
3	1H8397	RING	2
4	5M2997	SEAL	2
5	5M2998	RING	2
6	6H6269	RING	4
7	1S816	PILOT ASSEM.	2
8	8H7980	PISTON	2
9	1S5331	CYLINDER	2
10	2M3514	SHIM	12
11	3P9989	PLATE	4
12	9M9760	BEARING	2
13	9M9758	(Right Hand Inner-Left Hand Outer)	2
14	4S8984	SHAFT (idler)	4
15	9M9730	SEAL GROUP	4
16	3B1915	RING	4
17	384506	LOCKWASHER	24
18	9M9729	SEAL	4
19	3P8432	BUSHING ASSEM.	4
20	9B2289	PIN	2
21	852539	BEARING	1
22	8M4390	SEAL	4
23	2P347	PLUG	2
24	2P2975	SEAL	2
25	1P7659	SHIM	48
26	9M9759	BEARING (R. H. Outer - L. H. Inner)	2
27	3P6060	COLLAR ASSEM.	4
28	3P6059	STRIP	1
29	4S9061	PACKING	2
30	3P2196	SLEEVE	2
31	3P2198	BOLT	2
32	2M369	PILOT	2
33	51620	BOLT	2
34	2S1654	WASHER	2
35	9M3770	NUJ	2

201820

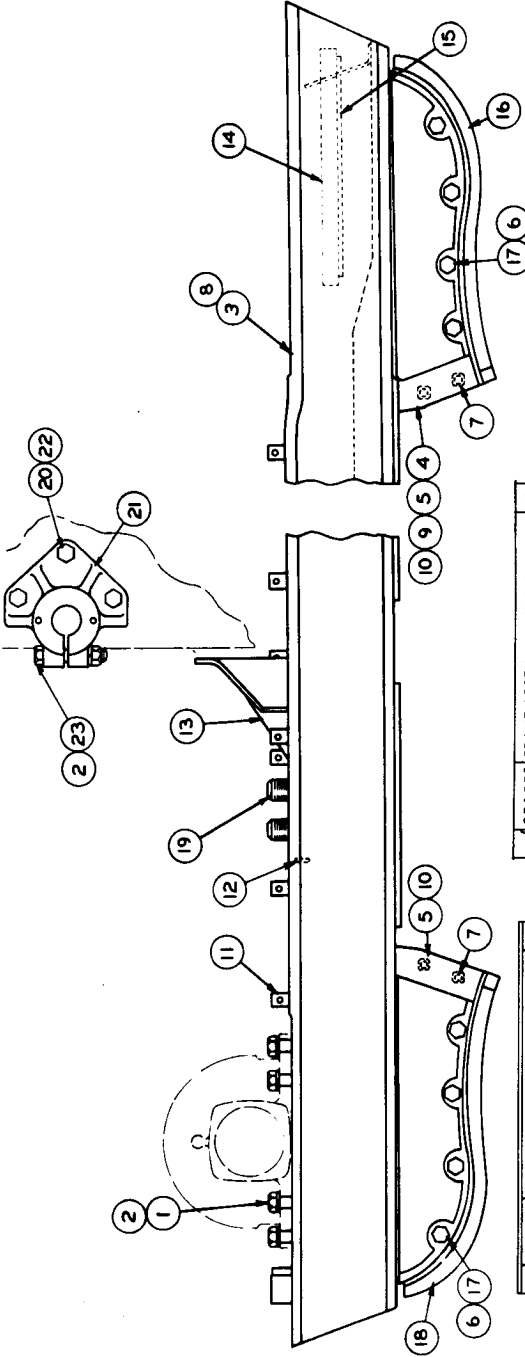

REF. NO.	PART NUMBER	DESCRIPTION	QTY.
1	1D4609	BOLT	8
2	3B4512	LOCKWASHER	16
3	2P1551	FRAME ASSEM. --- (R. H.)	1
4	1F1006	DOWEL	4
4	9S5294	GUARD ASSEM. --- (Front Outer)	4
5	9S5293	GUARD ASSEM.	2
6	L1325	WASHER --- (Rear Outer - Front Inner)	24
7	2M2933	NUT --- (Parts of 2P1551 Assem.)	12
		(One half each in 9S5294 & 9S5293 Assem.)	

8	2P1552	FRAME ASSEM. --- (L. H.)	1
8	1F1006	DOWEL	4
9	9S5293	GUARD ASSEM. --- (Front Outer)	4
10	9S5294	GUARD ASSEM. (Parts of 2P1552 Assem.)	2
11	2M473	LUG	24
12	1J3909	PLATE	2
13	1J1120	REINFORCEMENT	4
14	9S918	GUIDE ASSEM. (One half each in 2P1551 & 2P1552 Assem.)	4
15	9S917	STRIP (1 in each 9S918 Assem.)	4

16	9S1045	STRIP	3
17	S1566	BOLT	24
17	4D3704	WASHER --- (1.144 in. thick)	24
18	9S1046	STRIP	3
19	6J1551	BOLT	8
19	7S2831	WASHER	8
20	1D4625	BOLT	12
21	2P6	BRACKET	4
22	3B4514	LOCKWASHER	12
23	S1756	BOLT	8
23	1B4331	NUT	8

119196

C INDICATES CHANGE

NOTE: QUANTITIES SHOWN ARE THOSE REQUIRED FOR BOTH R. H. AND L. H. SIDES

TRACK ROLLER FRAME (2P1550 N/S)  
Serial No. 11K5051 to 11K5958 inclusive



TRACK ROLLER FRAME (3P1494 N/S)  
Serial No. 11K5959—Up

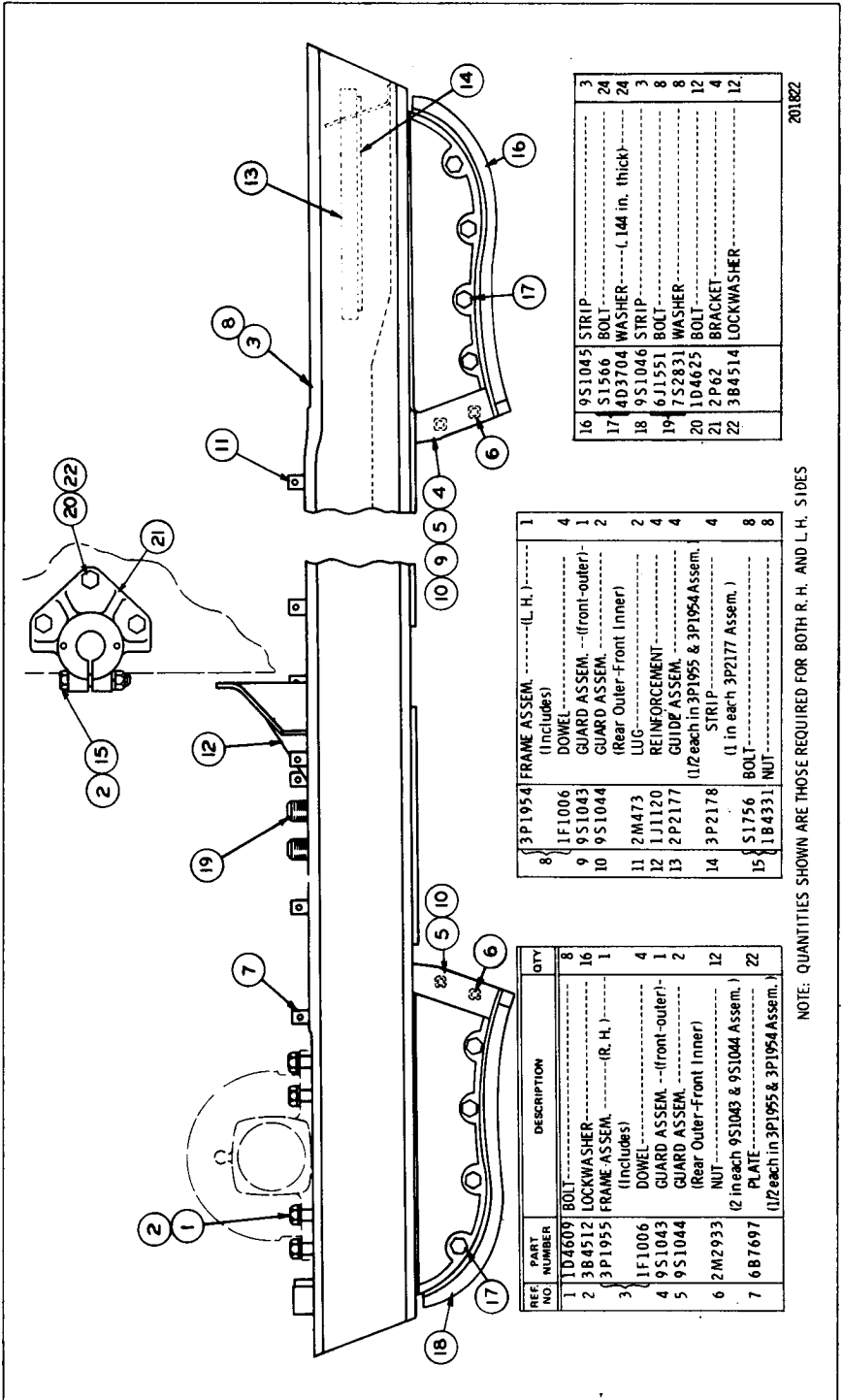

REF NO	PART NUMBER	DESCRIPTION	QTY
1	1D4609	BOLT	8
2	3B4512	LOCKWASHER	16
3	3P1955	FRAME ASSEM. (R. H.) (Includes)	1
4	1F1006	DOWEL	4
4	9S1043	GUARD ASSEM. --(front-outer)	1
5	9S1044	GUARD ASSEM. (Rear Outer-Front Inner)	2
6	2M2933	NUT	12
7	6B7697	PLATE (1/2 each in 3P1955 & 3P1954 Assem.)	22

8	3P1954	FRAME ASSEM. (L. H.) (Includes)	1
8	1F1006	DOWEL	4
9	9S1043	GUARD ASSEM. --(front-outer)	1
10	9S1044	GUARD ASSEM. (Rear Outer-Front Inner)	2
11	2M473	LUG	2
12	1L1120	REINFORCEMENT	4
13	2P2177	GUIDE ASSEM. (1/2 each in 3P1955 & 3P1954 Assem.)	4
14	3P2178	STRIP (1 in each 3P2177 Assem.)	4
15	S1756	BOLT	8
15	1B4331	NUT	8

16	9S1045	STRIP	3
17	S1566	BOLT	24
17	4D3704	WASHER - L. 144 in. thick	24
18	9S1046	STRIP	3
19	6J1551	BOLT	8
19	7S2831	WASHER	8
20	1D4625	BOLT	12
21	2P42	BRACKET	4
22	3B4514	LOCKWASHER	12

NOTE: QUANTITIES SHOWN ARE THOSE REQUIRED FOR BOTH R. H. AND L. H. SIDES

201822

5S3272 TRACK ROLLER FRAME GROUP  
 Part of 5S3270 Steel Mill Traxcavator Arrangement listed on Page 103  
 AN ATTACHMENT

NOTE: QUANTITIES SHOWN ARE THOSE REQUIRED  
 FOR BOTH R. H. AND L. H. FRAMES

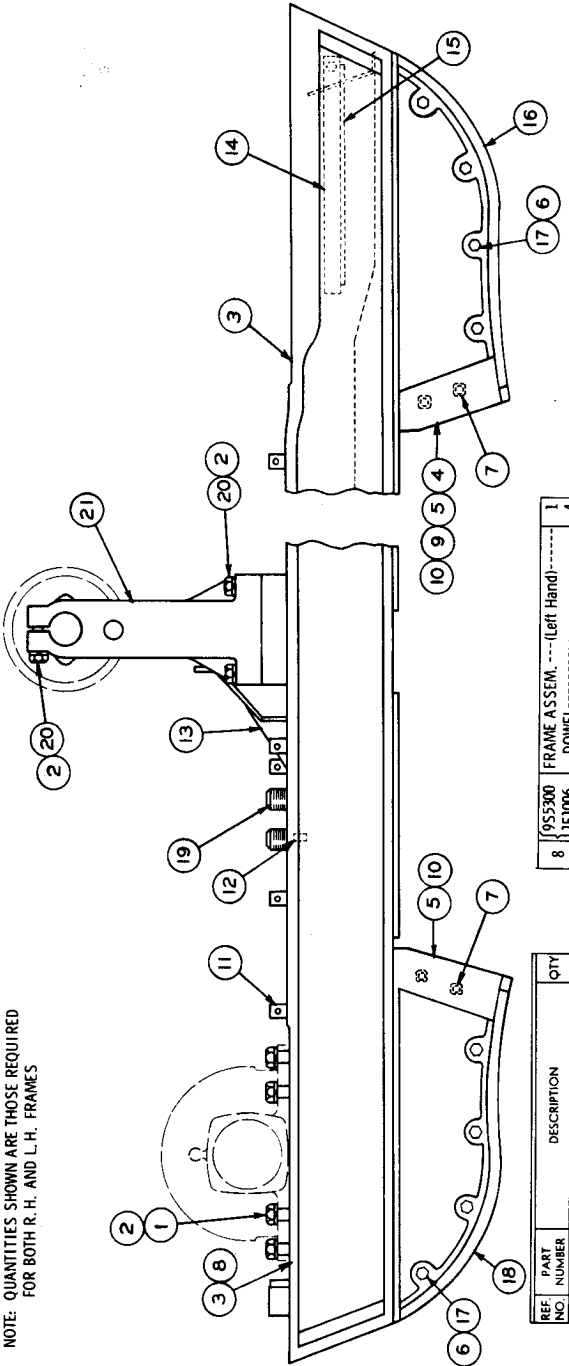

REF. NO.	PART NUMBER	DESCRIPTION	QTY
1	1D4609	BOLT	8
2	3B4512	LOCKWASHER	32
3	9S5299	FRAME ASSEM. --- (Right Hand)	1
4	1F1006	DOWEL	4
5	9S5293	GUARD ASSEM. --- (Front Outer)	1
6	L1325	WASHER	24
7	2M9333	NUT	12
(One Sixth each in 9S5294 & 9S5293 Assem.)			

8	9S5300	FRAME ASSEM. --- (Left Hand)	1
9	1F1006	DOWEL	4
9	9S5293	GUARD ASSEM. --- (Front Outer)	1
10	9S5294	GUARD ASSEM. --- (Rear Outer-Front Inner)	2
11	2M473	LUG	24
12	L13909	PLATE	2
13	L11120	REINFORCEMENT	4
14	9S918	GUIDE ASSEM.	4
C15	9S917	STRIP	4
(One half each in 9S5299 & 9S5300 Assem.)			
(1 in each 9S918 Assem.)			

16	9S1045	STRIP	3
17	51566	BOLT	24
18	3B4510	LOCKWASHER	24
18	9S1046	STRIP	3
19	9S2960	BOLT	8
20	1D4610	WASHER	24
21	7S9029	BRACKET	4

C INDICATES CHANGE

119018

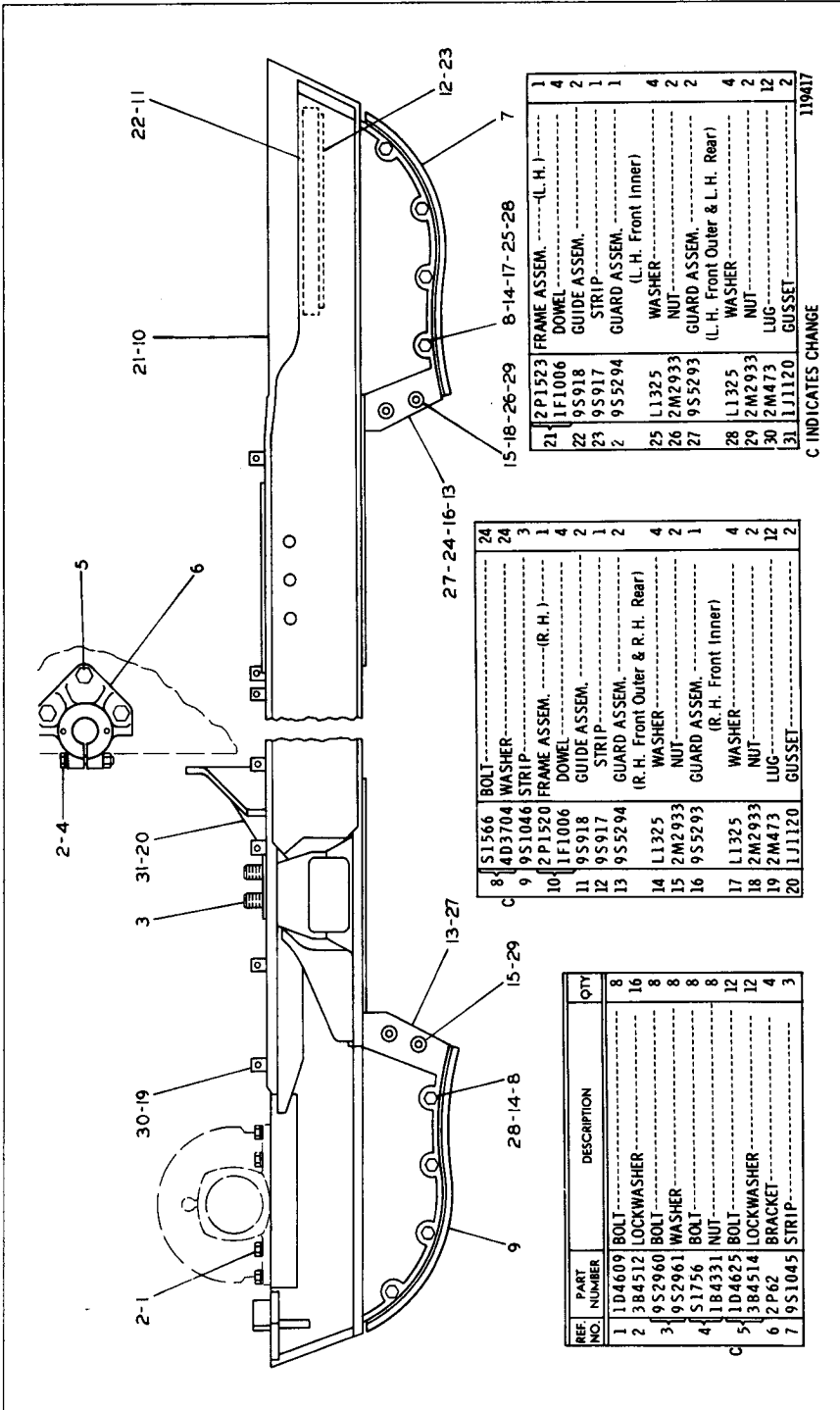

C INDICATES CHANGE  
119417

2P1575 TRACK ROLLER FRAME GROUP  
Part of 1P9409 Steel Mill Traxcavator Arrangement listed on Page 104  
NOTE: QUANTITIES SHOWN ARE THOSE REQUIRED FOR BOTH R.H. AND L.H. FRAMES  
AN ATTACHMENT

2S2061 TRACK ROLLER GUARD GROUP—Top View

Serial No. 11K5051 to 11K5958 inclusive

NOTE: QUANTITIES SHOWN ARE THOSE REQUIRED FOR BOTH R.H. AND L.H. FRAMES AN ATTACHMENT

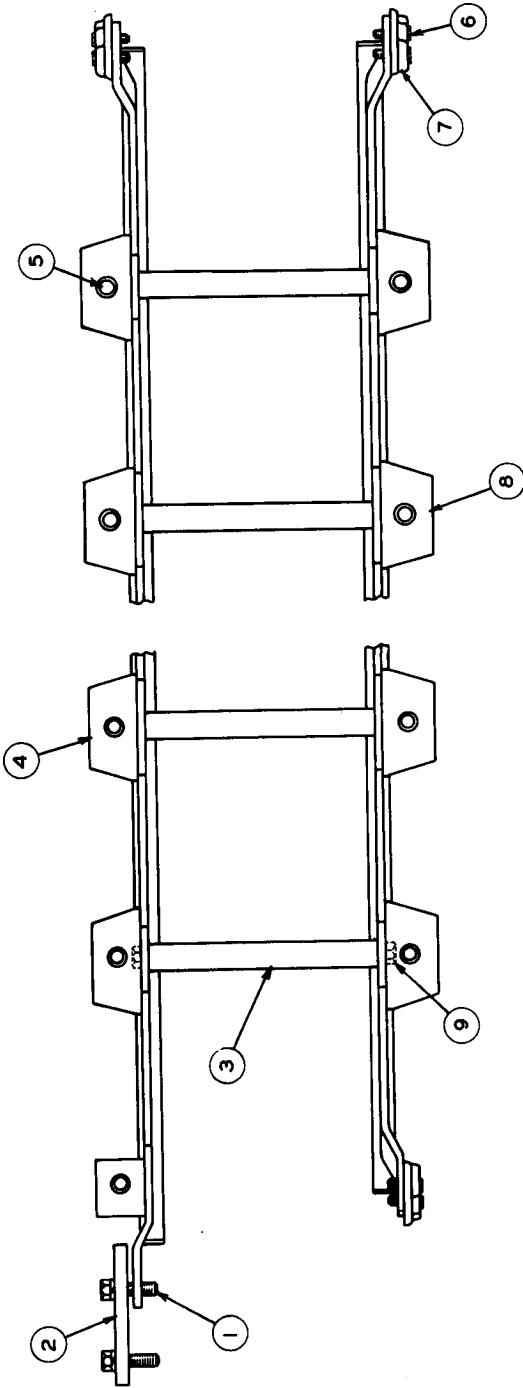

REF. NO.	PART NUMBER	DESCRIPTION	QTY.
1	1S-1625	BOLT	4
2	3B4510	LOCKWASHER	4
3	2M4665	PLATE	2
4	2M4387	PIPE	12
5	2S1917	GUARD ASSEM. (Right Hand-Inner)	1
6	2S1918	GUARD ASSEM. (Left Hand-Inner)	1

REF. NO.	PART NUMBER	DESCRIPTION	QTY.
5	1L-1178	BOLT	26
6	3B4512	LOCKWASHER	26
7	4B4283	WASHER	26
8	1S-1985	BOLT	12
9	3B4508	LOCKWASHER	12
10	2M4668	RETAINER	6

REF. NO.	PART NUMBER	DESCRIPTION	QTY.
8	2S1892	GUARD ASSEM. (Right Hand Outer-Left Hand Outer)	2
9	841383	ROD	12
	1L84208	NUT	24
	3B4514	LOCKWASHER	12

99511

3P2358 TRACK ROLLER GUARD GROUP—Top View

Serial No. 11K5959—Up

NOTE: QUANTITIES SHOWN ARE THOSE REQUIRED FOR BOTH R.H. AND L.H. FRAMES AN ATTACHMENT

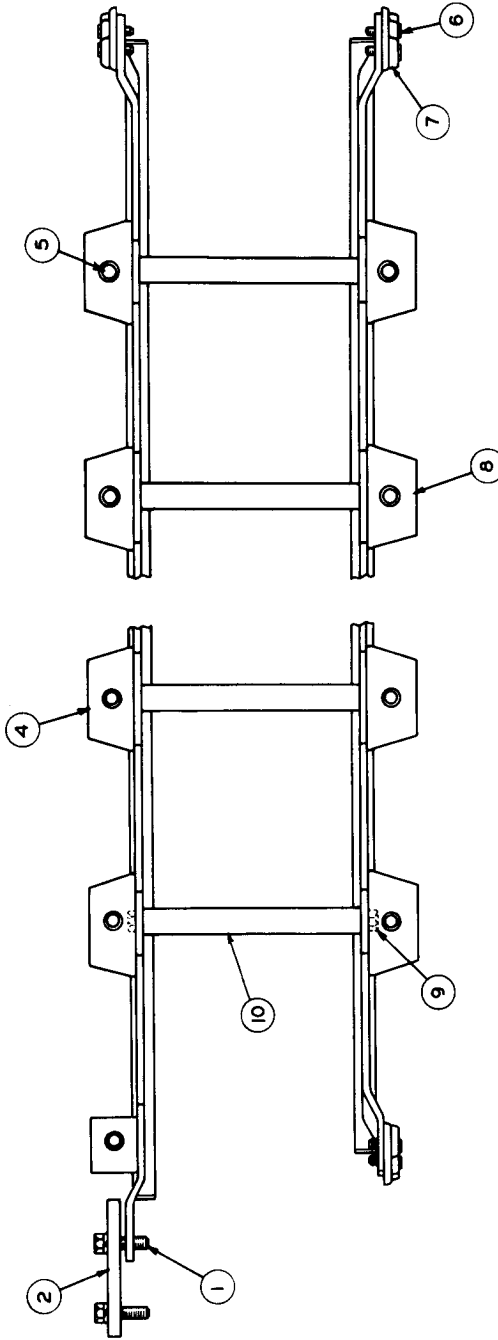

REF. NO.	PART NUMBER	DESCRIPTION	QTY
1	3S1625	BOLT	4
1	3B4510	LOCKWASHER	4
2	2M4665	PLATE	2
4	3P1925	GUARD ASSEM. --- (R. H. -inner)---	1
4	3P1926	GUARD ASSEM. --- (L. H. -inner)---	1

5	1D4626	BOLT	26
3	3P9111	SPACER	26
5	S1585	BOLT	12
3	3B4508	LOCKWASHER	12
7	2M4668	RETAINER	6

8	3P1927	GUARD ASSEM. --- (R. H. Outer-L. H. Outer)	2
9	1B1383	ROD	12
9	1B4208	NUT	24
3	3B4514	LOCKWASHER	24
10	2F25	TUBE	12

201827

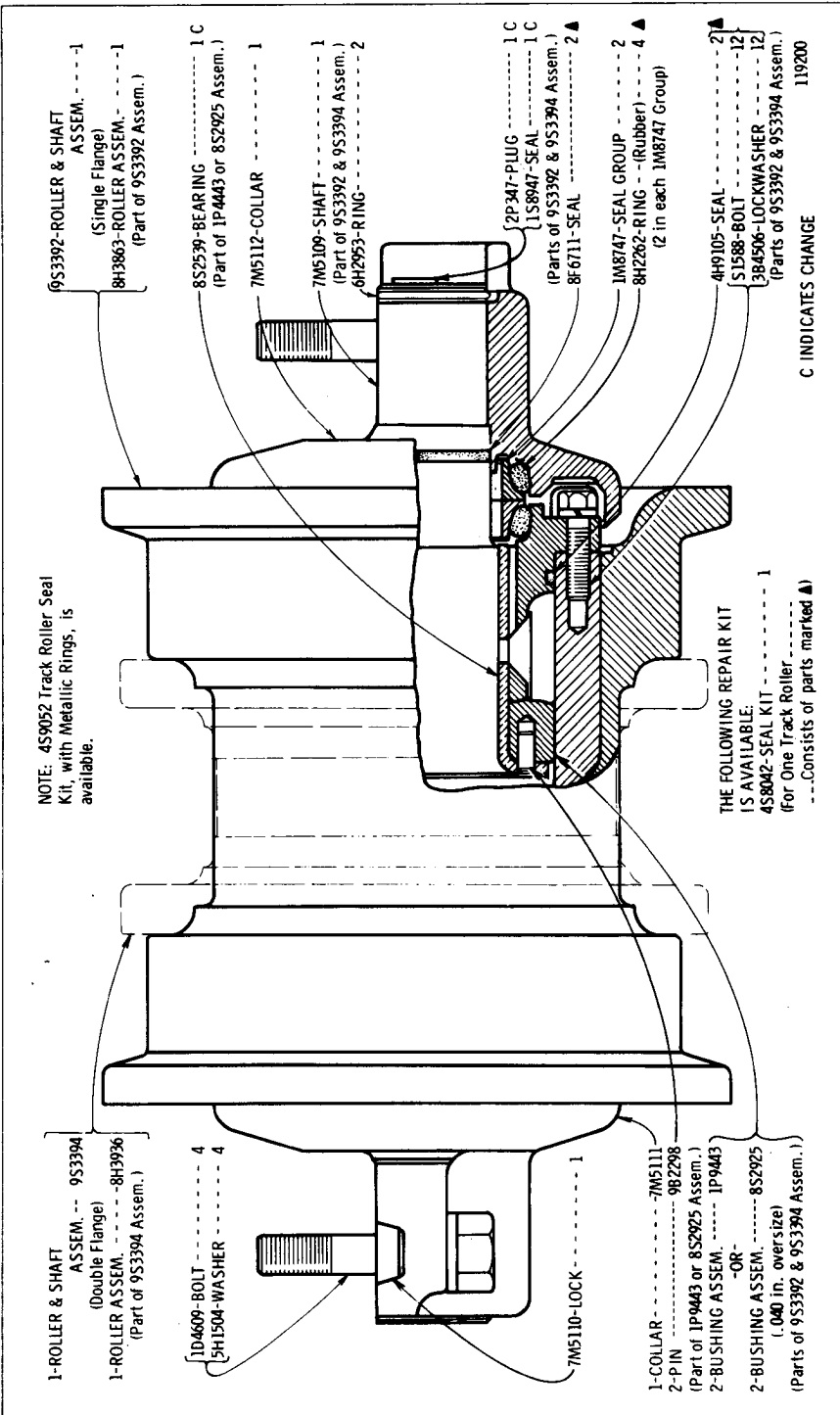

9S3383 TRACK ROLLER GROUP—Single Flange—6 Required  
 9S3395 TRACK ROLLER GROUP—Double Flange—8 Required  
 Serial No. 11K5061 to 11K5680 Inclusive

1P9100 TRACK ROLLER GROUP—Single Flange—6 Required  
 Serial No. 11K5681 to 11K5958 inclusive

REF. NO.	PART NUMBER	DESCRIPTION	QTY
1	1D4609	BOLT	4
2	5H1504	WASHER	4
3	6H2953	RING	2

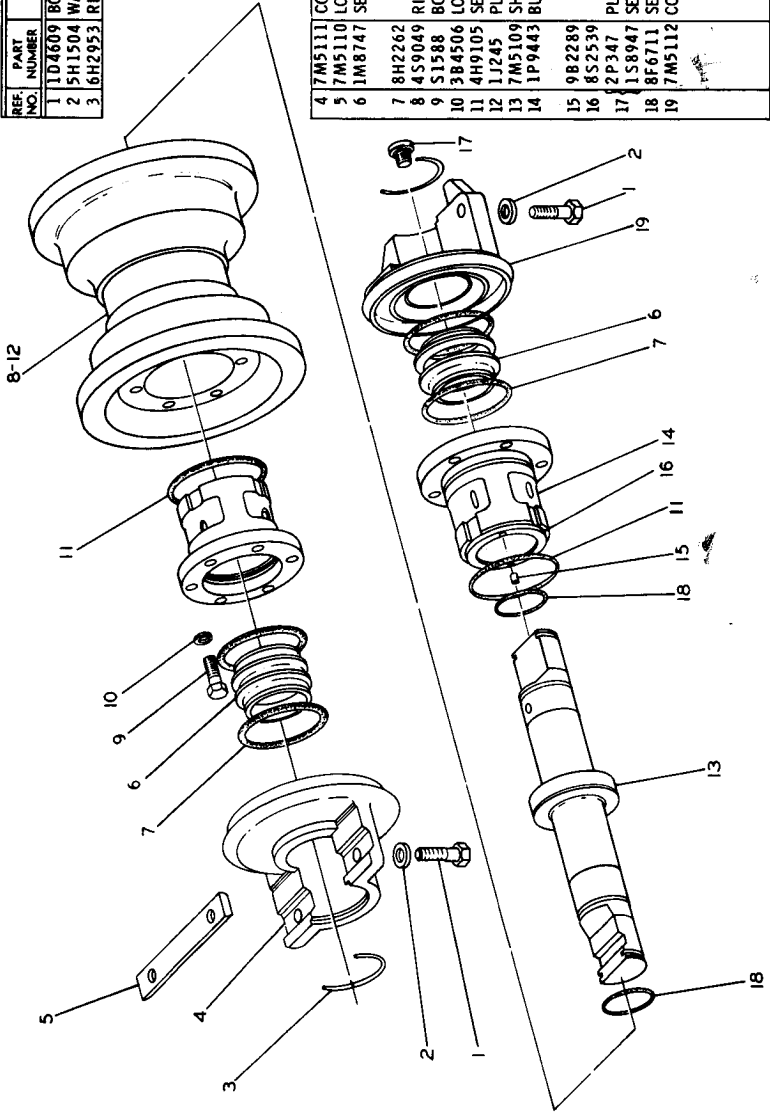

4	7M5111	COLLAR	1
5	7M5110	LOCK	1
6	1M8747	SEAL GROUP (Each Includes)	2
7	8H2262	RING	2
8	4S9049	RIM	1
9	51588	BOLT	12
10	3B4506	LOCKWASHER	12
11	4H9105	SEAL	2
12	1J245	PLUG	2
13	7M5109	SHAFT	1
14	1P9443	BUSHING ASSEM. (Each Includes)	2
15	9B2289	PIN	2
16	8S2539	BEARING	1
17	2P347	PLUG	1
18	1S8947	SEAL	1
18	8F6711	SEAL	2
19	7M5112	COLLAR	1

146772

REF. NO.	PART NUMBER	DESCRIPTION	QTY
1	1D4609	BOLT	4
2	5H1504	WASHER	4
3	6H2953	RING	2

4	7M5111	COLLAR	1
5	7M5110	LOCK RING	1
6	1M8747	SEAL GROUP (Each Includes)	2
7	8H2262	RING	2
8	8S2931	RIM ASSEM.	1
9	51588	BOLT	12
10	3B4506	LOCKWASHER	12
11	4H9105	SEAL	2
12	1J245	PLUG	2
13	7M5109	SHAFT	1
14	1P8787	BUSHING ASSEM. (Each Includes)	2
15	9B2289	PIN	2
16	8S2539	BEARING	1
17	2P347	PLUG	1
18	1S8947	SEAL	1
18	8F6711	SEAL	2
19	7M5112	COLLAR	1

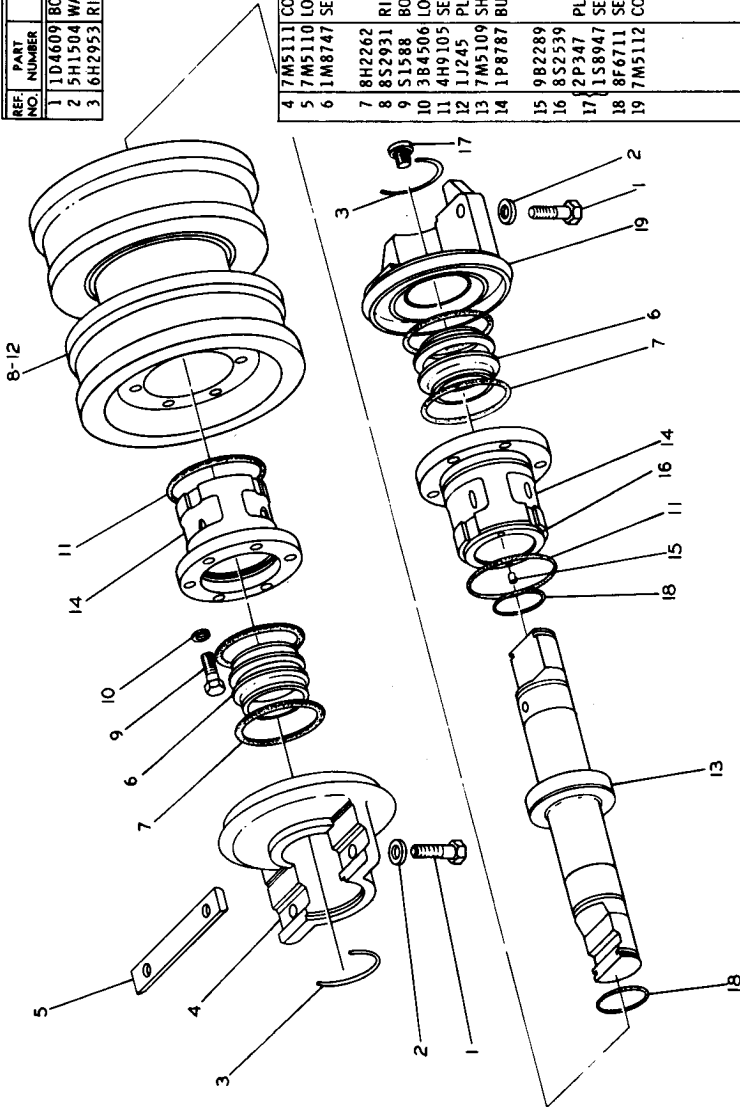

16773

1P9102 TRACK ROLLER GROUP—Double Flange—8 Required  
Serial No. 11K5681 to 11K5958 inclusive



4S9051 TRACK ROLLER GROUP—Single Flange—6 Required  
Serial No. 11K5959—Up

REF. NO.	PART NUMBER	DESCRIPTION	QTY
1	1D4629	BOLT	4
2	9H1031	WASHER	4
3	6H2953	RING	4
			2

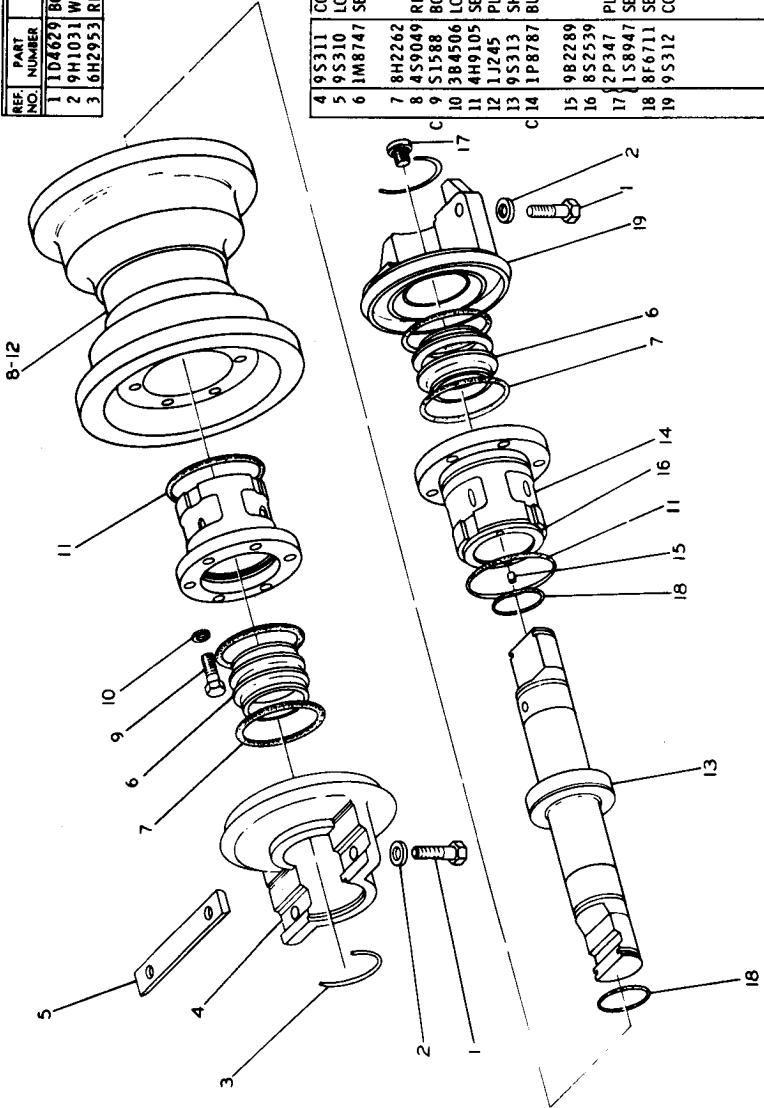

4	9S311	COLLAR	1
5	9S310	LOCK	2
6	1M8747	SEAL GROUP (Each Includes)	2
7	8H2262	RING	2
8	4S9049	RIM	1
9	51588	BOLT	12
10	3B4506	LOCKWASHER	12
11	4H9105	SEAL	2
12	11245	PLUG	2
13	9S313	SHAFT	1
14	1P8787	BUSHING ASSEM. (Each Includes)	2
15	9B2289	PIN	2
16	8S2539	BEARING	1
17	2P347	PLUG	1
18	1S8947	SEAL	1
18	8F6711	SEAL	2
19	9S312	COLLAR	1

C INDICATES CHANGE

205314

REF. NO.	PART NUMBER	DESCRIPTION	QTY
1	1D4629	BOLT	4
2	9H1031	WASHER	4
3	6H2953	RING	2

4	95311	COLLAR	1
5	95310	LOCK	2
6	1M8747	SEAL GROUP (Each Includes)	2
7	8H2262	RING	2
8	852931	RIM ASSEM.	1
9	51588	BOLT	12
10	384506	LOCKWASHER	12
11	4H9105	SEAL	2
12	11245	PLUG	2
13	95313	SHAFT	1
14	1P8787	BUSHING ASSEM. (Each Includes)	2
15	982289	PIN	2
16	852539	BEARING	1
17	2P347	PLUG	1
18	158947	SEAL	2
18	8F6711	SEAL	2
19	95312	COLLAR	1

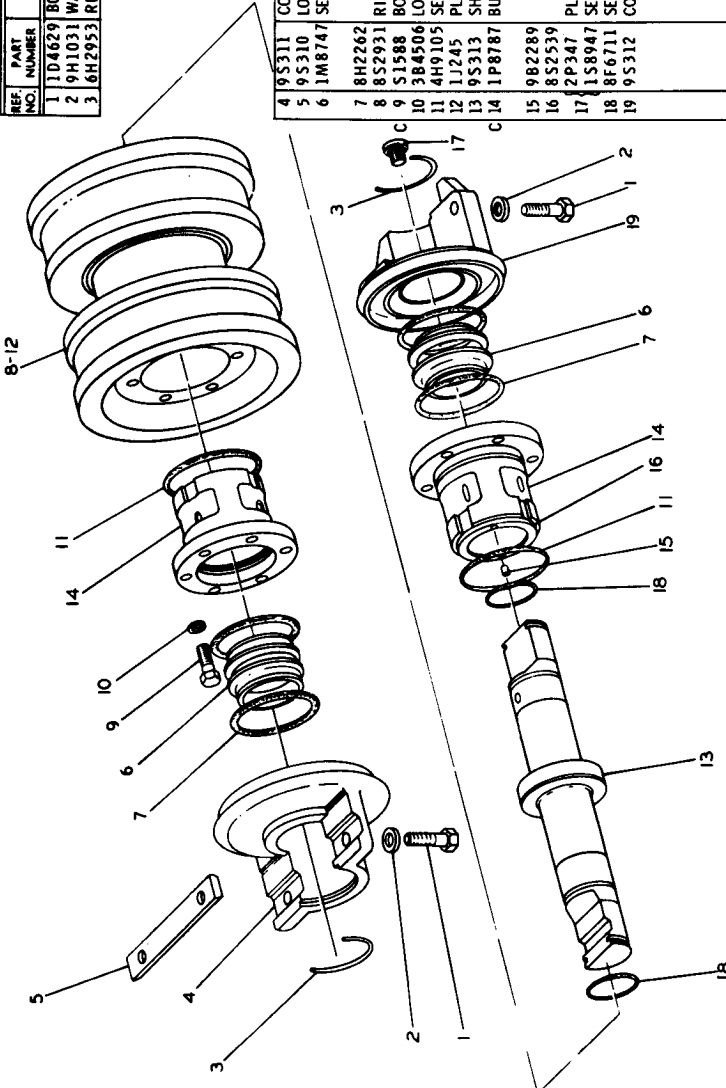

C INDICATES CHANGE

209313

8S2933 TRACK ROLLER GROUP—Double Flange—8 Required  
Serial No. 11K5959—Up

9S7284 TRACK ROLLER GROUP—Single Flange—6 Required  
 9S7386 TRACK ROLLER GROUP—Double Flange—8 Required  
 Part of 5S3270 and 1P9409 Steel Mill Traxcavator Arrangements listed on Pages 103 and 104  
 AN ATTACHMENT

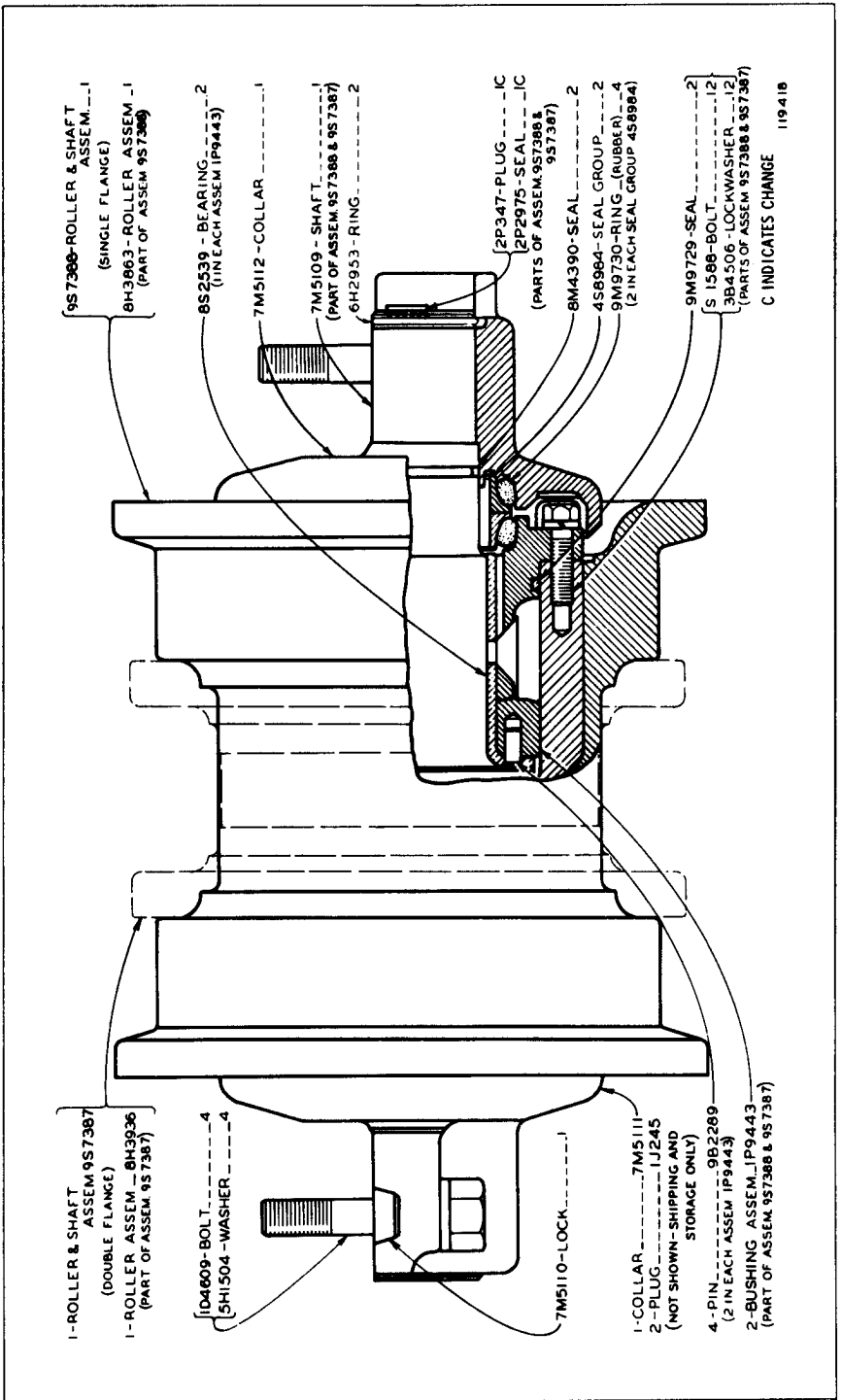

REF. NO.	PART NUMBER	DESCRIPTION	QTY
1	1D4609	BOLT	4
2	5H1504	WASHER	4
3	16H2953	RING	2

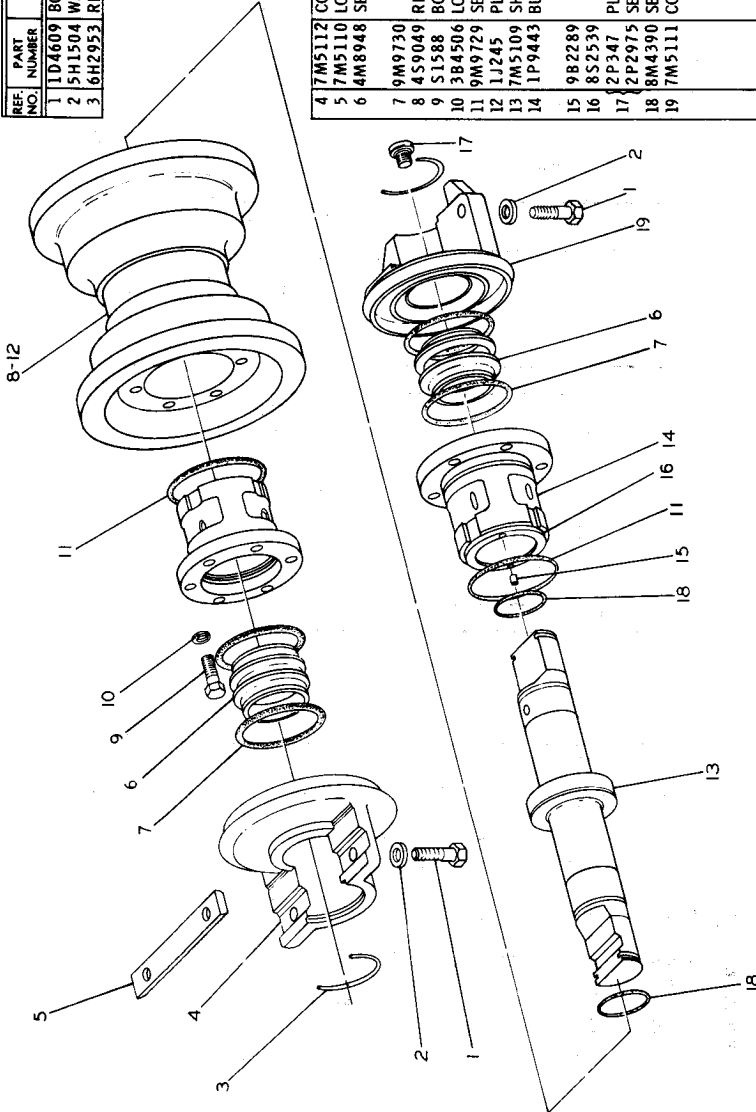

4	7M5112	COLLAR	1
5	7M5110	LOCK	1
6	4M8948	SEAL GROUP (Each Includes)	2
7	9M9730	RING	2
8	4S9049	RIM ASSEM.	1
9	51588	BOLT	12
10	3B4506	LOCKWASHER	12
11	9M9729	SEAL	2
12	1J245	PLUG	2
13	7M5109	SHAFT	1
14	1P9443	BUSHING ASSEM. (Each Includes)	2
15	982289	PIN	2
16	8S2539	BEARING	1
17	2P347	PLUG	1
18	8M4390	SEAL	1
19	7M5111	COLLAR	2

145724

1P9400 TRACK ROLLER GROUP—Single Flange—6 Required  
 Serial No. 11K5681 to 11K5958 inclusive  
 Part of 1P9409 Steel Mill Traxcavator Arrangement listed on Page 104

1P9402 TRACK ROLLER GROUP—Double Flange—8 Required  
 Serial No. 11K5681 to 11K5958 inclusive  
 Part of 1P9409 Steel Mill Traxcavator Arrangement listed on Page 104

REF. NO.	PART NUMBER	DESCRIPTION	QTY.
1	1D4609	BOLT	4
2	5H1504	WASHER	4
3	6H2953	RING	2

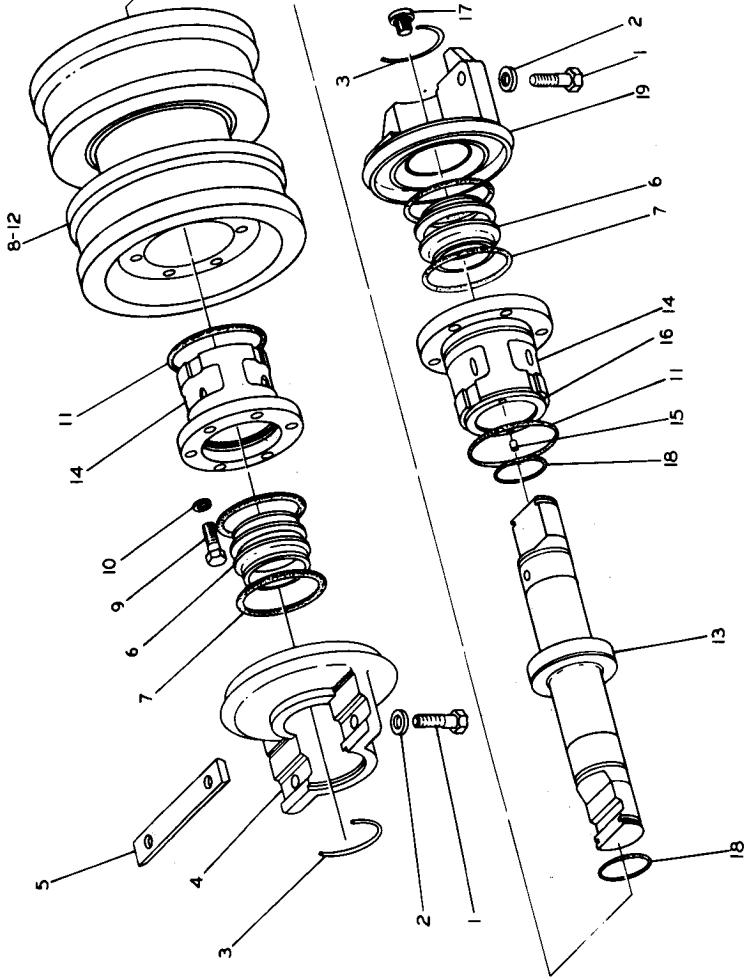

4	7M5112	COLLAR	1
5	7M5110	LOCK	2
6	4S8984	SEAL GROUP	2
7	9M9730	RING	2
8	8S2931	RIM ASSEM.	1
9	5I588	BOLT	12
10	3B4506	LOCKWASHER	12
11	9M9729	SEAL	2
12	1J245	PLUG	2
13	7M5109	SHAFT	1
14	1P8787	BUSHING ASSEM.	2
15	9B2289	PIN	2
16	8S2539	BEARING	2
17	2P347	PLUG	1
18	2P2975	SEAL	1
19	8M4390	SEAL	2
	7M5111	COLLAR	1

145725

REF. NO.	PART NUMBER	DESCRIPTION	QTY
1	1D4629	BOLT	4
2	9H1031	WASHER	4
3	6H2953	RING	2

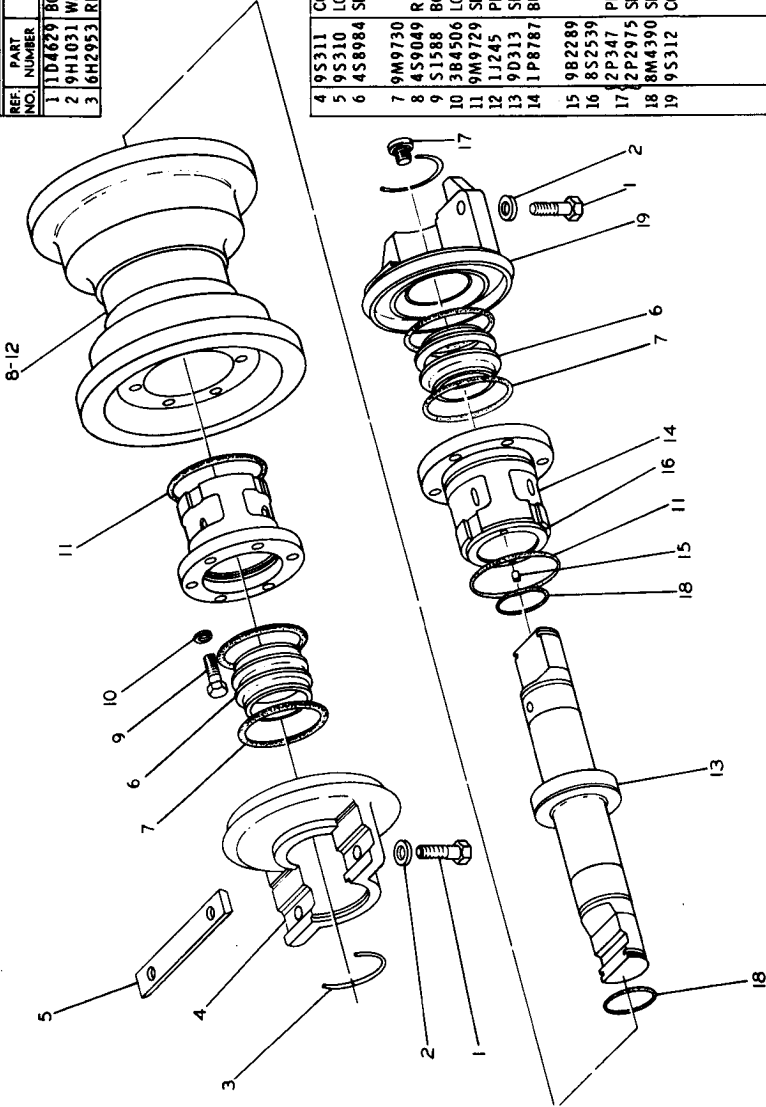

4	9S311	COLLAR	(inner)	1
5	9S310	LOCK		1
6	4S8984	SEAL GROUP	(Each Includes)	2
7	9M9730	RING		2
8	4S9049	RIM ASSEM.		1
9	51588	BOLT		12
10	3B4506	LOCKWASHER		12
11	9M9729	SEAL		2
12	1J245	PLUG		2
13	9D313	SHAFT		1
14	1P8787	BUSHING ASSEM.	(Each Includes)	2
15	9B2289	PIN		2
16	8S2539	BEARING		1
17	2P347	PLUG		1
18	2P2975	SEAL		1
18	8M4390	SEAL	(outer)	2
19	9S312	COLLAR	(outer)	1

201829

3P1520 TRACK ROLLER GROUP—Single Flange—6 Required  
 Serial No. 11K5959—Up  
 Part of 3P1469 Steel Mill Traxcavator Arrangement listed on Page 104A



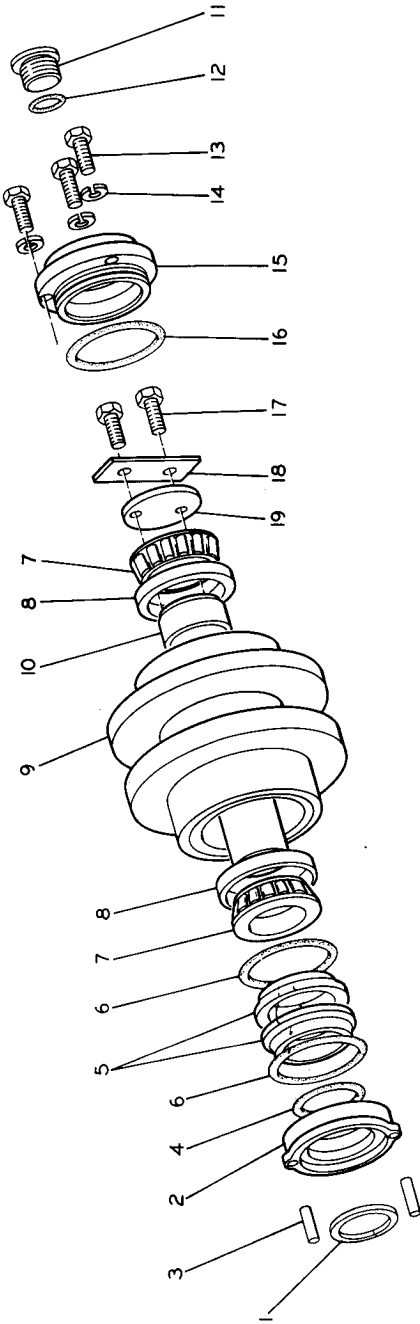

13	SI1594	BOLT	3
14	3B4506	LOCKWASHER	1
15	5M2043	COVER	1
16	2H6338	SEAL	1
17	T703	BOLT	2
18	T329	LOCK	1
19	9S3568	PLATE	1

5	1M8747	SEAL GROUP	1
6	8H2262	RING	2
7	9S3582	CONE	2
8	9S3581	CUP	2
9	1P8716	ROLLER ASSEM.	1
10	1P8715	SHAFT	1
11	2P347	PLUG	1
12	1S8947	SEAL	1

REF. NO.	PART NUMBER	DESCRIPTION	QTY.
1	7H4574	RING	1
2	7H4571	COLLAR ASSEM.	1
3	1M4291	DOWEL	2
4	1H8720	SEAL	1

138580

1P8717 TRACK CARRIER ROLLER GROUP—4 Required



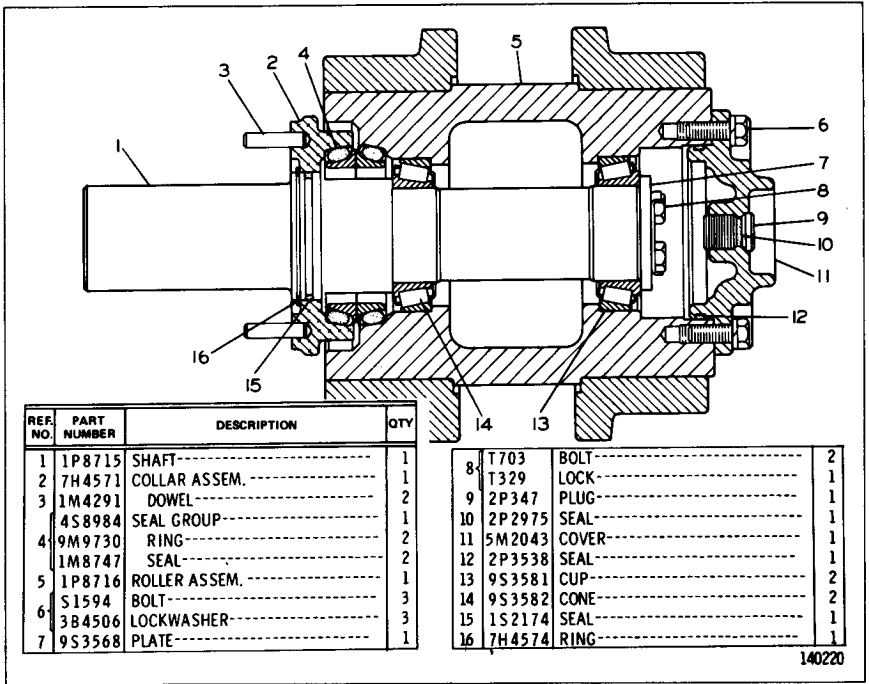

2P3514 TRACK CARRIER ROLLER GROUP—4 Required  
Part of 5S3270, 1P9409 and 3P1469 Steel Mill Traxcavator Arrangements listed on Pages 103, 104 and 104A. AN ATTACHMENT

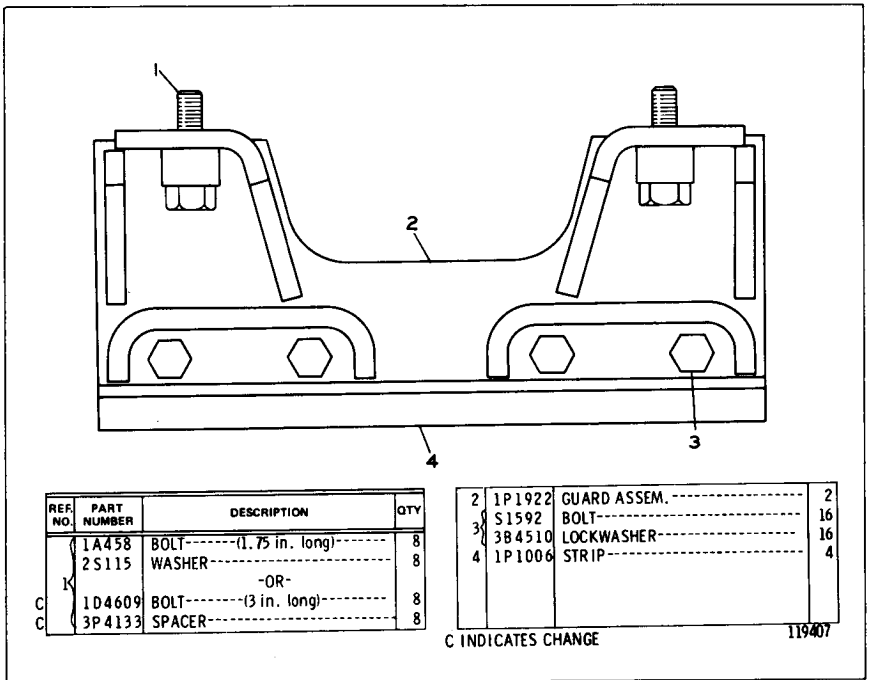

1P1923 TRACK GUIDING CENTER GUARD GROUP  
Serial No. 11K5051 to 11K5958 inclusive  
AN ATTACHMENT

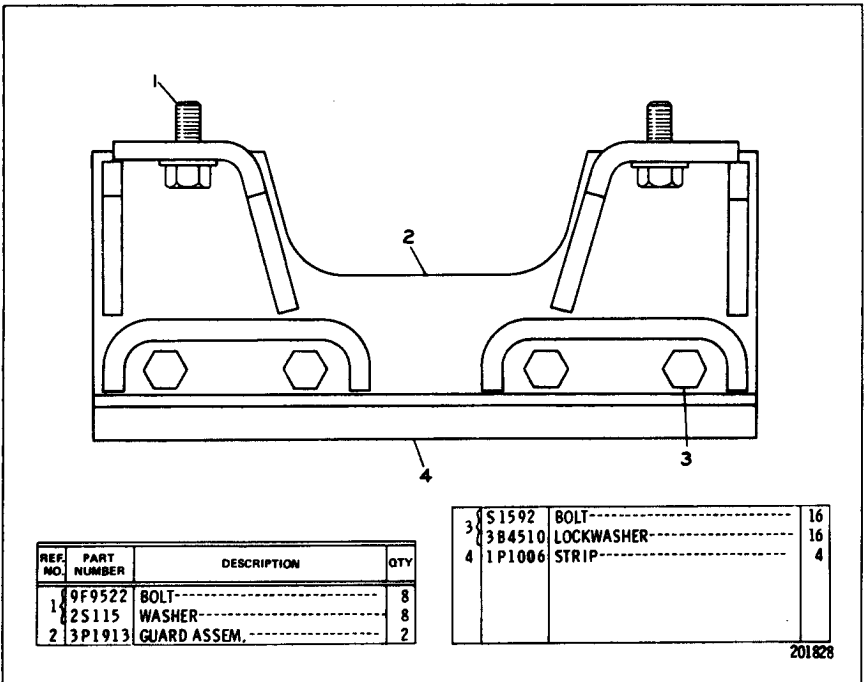

REF. NO.	PART NUMBER	DESCRIPTION	QTY
1	9F9522	BOLT-----	8
1	2S115	WASHER-----	8
2	3P1913	GUARD ASSEM.-----	2

3	51592	BOLT-----	16
3	384510	LOCKWASHER-----	16
4	1P1006	STRIP-----	4

201828

3P1914 TRACK GUIDING CENTER GUARD GROUP  
 Serial No. 11K5959—Up  
 AN ATTACHMENT

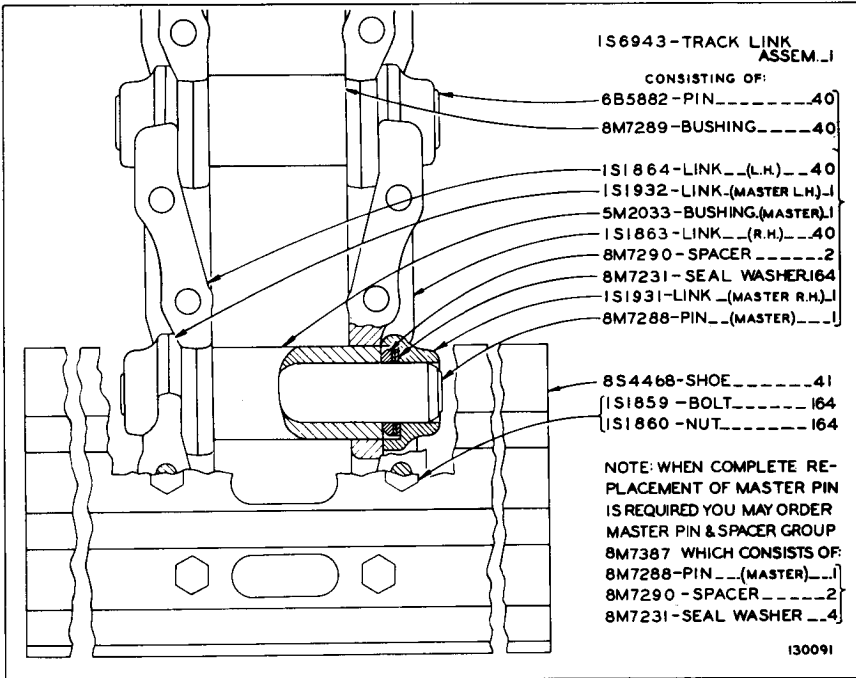

8S4469 TRACK GROUP—18" Triple Grouser Shoe—2 Required  
 Note: 8M7385 Track Pin & Bushing Group, consisting of a complete set of Pins and Bushings for one Track, is available

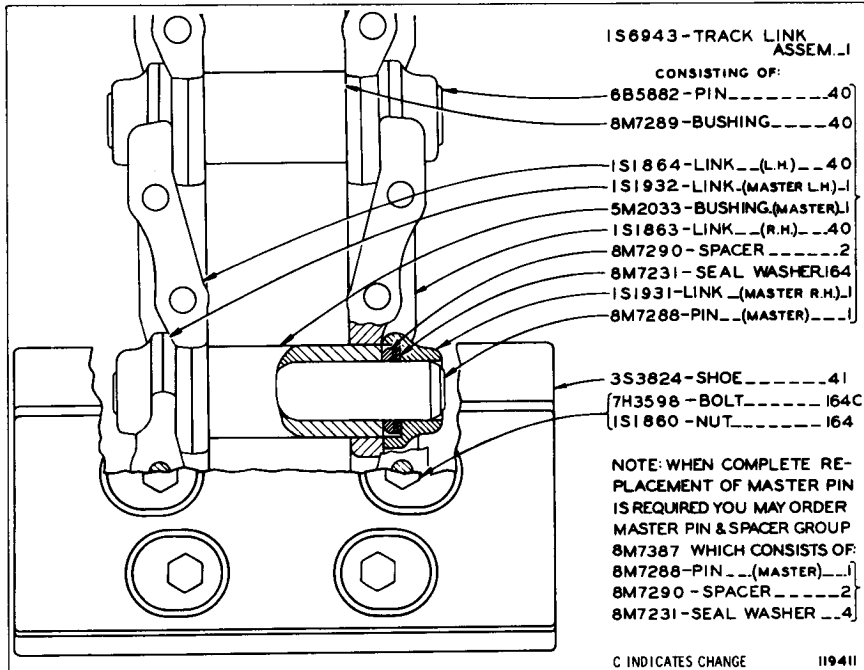

8S1884 TRACK GROUP—16" Flat Shoe—2 Required  
 Note: 8M7385 Track Pin & Bushing Group, consisting of a complete set of Pins and Bushings for one Track, is available  
 AN ATTACHMENT

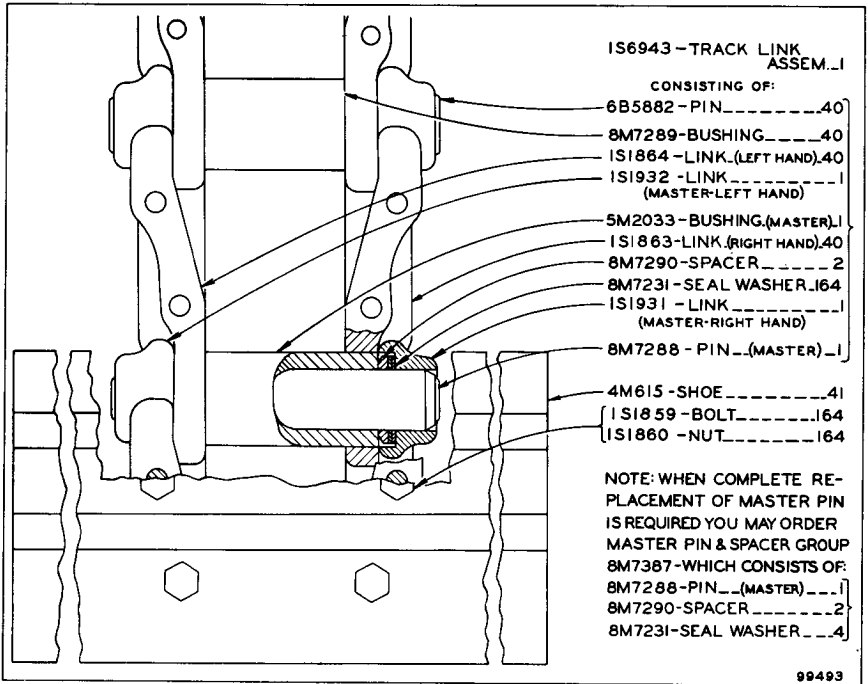

5S117 TRACK GROUP—18" Double Grouser Shoe—2 Required  
 Serial No. 11K5051 to 11K5958 inclusive. Note: 8M7385 Track Pin and Bushing Group, consisting of a complete set of Pins and Bushings for one Track, is available. AN ATTACHMENT

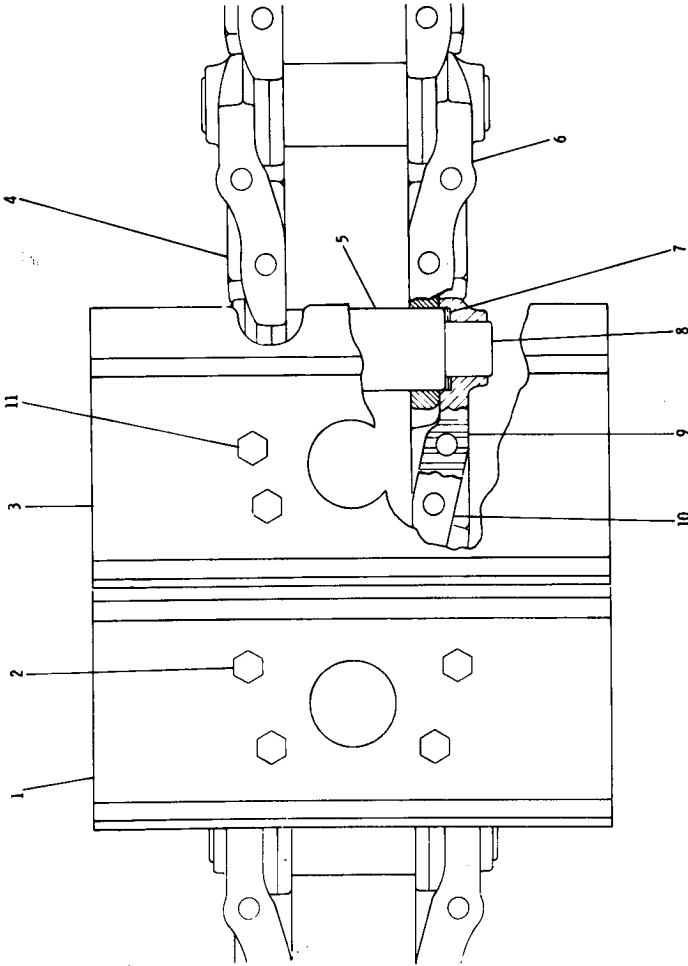

REF. NO.	PART NUMBER	DESCRIPTION	QTY
1	3P980	SHOE	38
2	7H3598	BOLT	152
3	1S1860	NUT	152
3	3P979	SHOE (master)	1
4	3P958	LINK ASSEM. (includes)	1
4	8S2590	LINK (L. H.)	38
5	1M3669	BUSHING	39
6	8S2589	LINK (R. H.)	38
7	8M6239	SEAL	156
8	1M8958	PIN	39
8	2P9653	LINK (master)	1
9	2P9654	LINK (R. H. - Pin End)	1
9	2P9654	LINK (L. H. - Pin End)	1
10	2P9655	LINK (master)	1
10	2P9656	LINK (R. H. - Bushing End)	1
10	2P9656	LINK (L. H. - Bushing End)	1
11	2P9670	BOLT	4

202105

3P944 TRACK GROUP—18" Double Grouser Shoe—2 Required  
Serial No. 11K5959—Up

3P1433 TRACK GROUP—16" Flat Shoe—2 Required  
 Serial No. 11K5959—Up  
 FOR USE WHERE EXTREME HIGH TEMPERATURES ARE ENCOUNTERED  
 AN ATTACHMENT

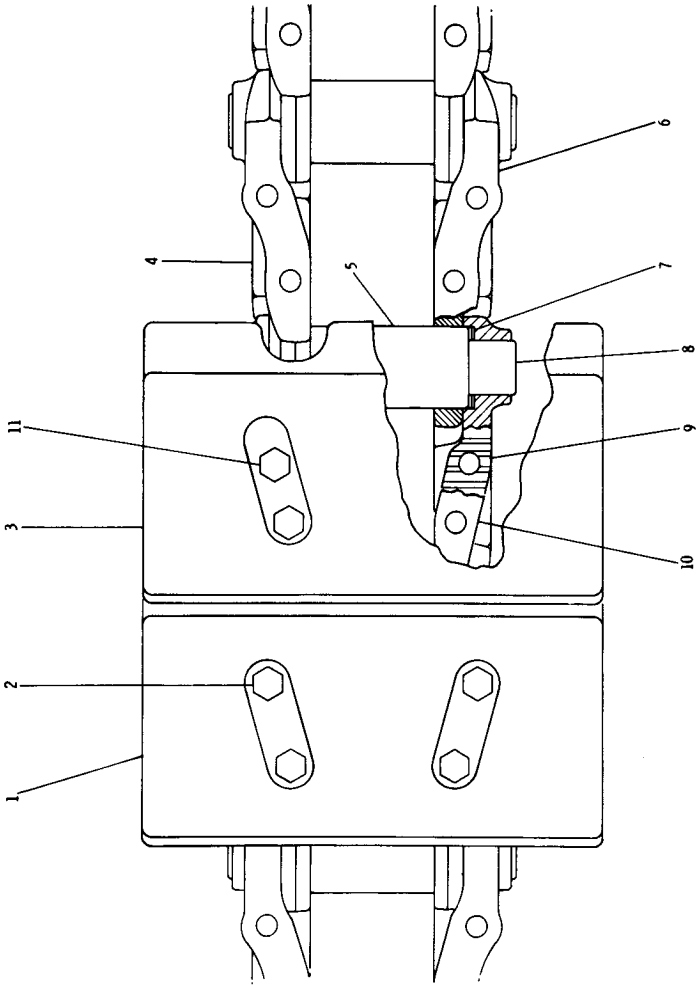

REF. NO.	PART NUMBER	DESCRIPTION	QTY
1	3P1431	SHOE-----	38
2	7H3598	BOLT-----	152
3	1S1860	NUT-----	152
3	3P1432	SHOE-----	1
3	3P958	LINK ASSEM.	1
4	8S2590	(Includes)	
5	1M3669	LINK-----	38
5	1M3669	BUSHING-----	39
6	8S2589	LINK-----	38
7	8M6239	SEAL-----	156
8	1M8958	PIN-----	39
8	2P9653	LINK-----	1
9	2P9654	(R. H. - Pin End)	
9	2P9654	LINK-----	1
9	2P9654	-----	
9	2P9654	(L. H. - Pin End)	
9	2P9654	LINK-----	1
10	2P9655	(R. H. - Bushing End)	
10	2P9655	LINK-----	1
10	2P9655	-----	
10	2P9655	(L. H. - Bushing End)	
10	2P9655	LINK-----	1
10	2P9655	-----	
10	2P9655	(L. H. - Bushing End)	
10	2P9655	LINK-----	1
11	2P9670	BOLT-----	4

REF. NO.	PART NUMBER	DESCRIPTION	QTY
1	3S5715	GUIDE-----	1
C 2	7K1381	LEVER----- (Lift)-----	1
3	L1170	HANDLE-----	2
C 4	7K1382	LEVER----- (Tilt)-----	1
5	4B1280	SCREW-----	4
6	6K1267	SHAFT ASSEM.-----	4
6	6K647	BEARING-----	4
7	S509	BOLT-----	1
7	3B4506	LOCKWASHER-----	1
C 8	S1587	BOLT-----	4
8	1K6872	NUT-----	4
9	3S4935	SPACER-----	1
9	1L3046	WASHER-----	4
C 10	4K1348	ROD-----	1
C 11	5H6816	ROD-----	1
C 12	1B4430	NUT-----	4
C 13	4D4065	END-----	4

C INDICATES CHANGE

113893

HYDRAULIC HAND CONTROL (3S4673 N/S)

REF. NO.	PART NUMBER	DESCRIPTION	QTY
1	L478	BOLT-----	1
1	5B9079	NUT-----	1
2	3B4506	LOCKWASHER-----	1
3	L1170	HANDLE-----	1
4	8B8679	SPACER-----	1
5	6K2463	LEVER ASSEM.-----	1
5	1B8706	KEY-----	2
6	5K2294	BEARING-----	2
7	6K2651	SHAFT-----	1
C 8	S1590	BOLT-----	1
8	1D4717	NUT-----	1
9	S175	PIN-----	2
9	3B4617	COTTER PIN-----	2
10	6K2611	ROD-----	1
11	7K7821	BRACKET ASSEM.-----	1
12	1F748	NUT----- (Weld)-----	2
13	3B4508	LOCKWASHER-----	4
C 14	9K1106	LEVER-----	1
15	S1621	BOLT-----	2
16	6K2555	BRACKET ASSEM.-----	1
17	S1595	BOLT-----	2
C 18	S1591	BOLT-----	1

C INDICATES CHANGE

140404

5K6276 HAND CONTROL GROUP—Rear  
 Part of 2P8033, 5K9839, 3P7544, 3P7545 and 2P8034  
 Arrangements listed on Pages 148B, 148C, 148D and 149

6K2500 HAND CONTROL GROUP—Front and Rear  
 Part of 2P8030, 9K4118, 5K6278, 3P7546, 3P7547, 5K9873 and 9K4343 Arrangements listed on Pages 148, 148A, 148B, 148D and 149

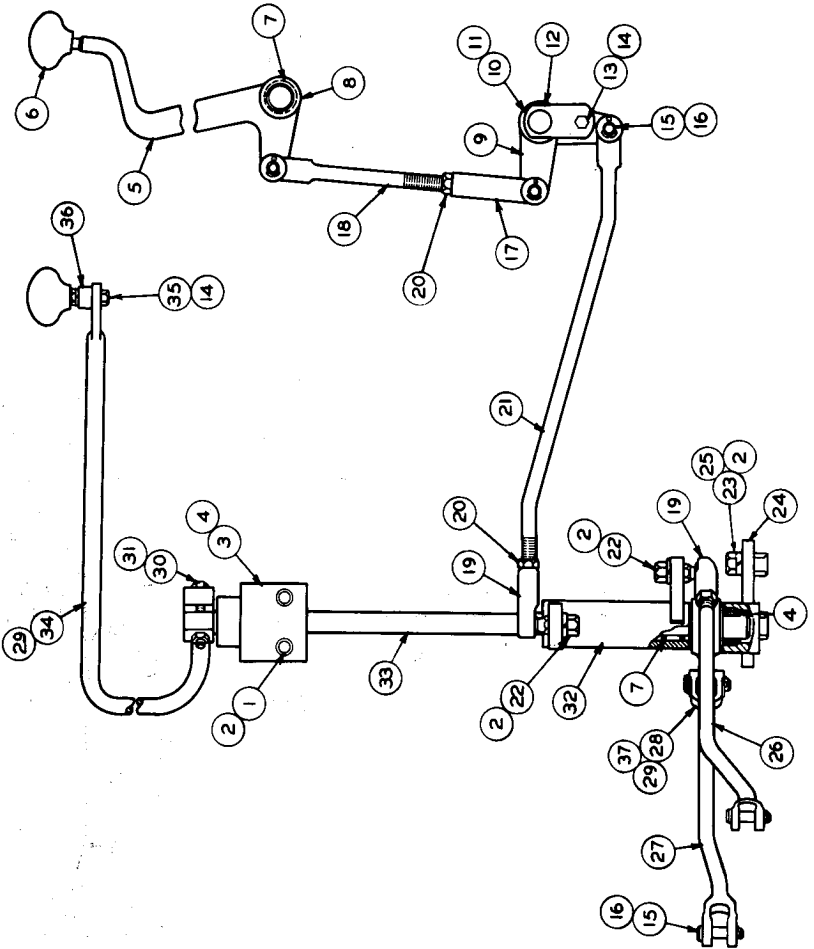

REF NO	PART NUMBER	DESCRIPTION	QTY
1	S1595	BOLT	2
2	3B4508	LOCKWASHER	6
3	6K2555	BRACKET ASSEM	1
4	5K2294	BEARING	2
5	7K1383	LEVER	1
6	L1170	HANDLE	2
7	6K647	BEARING	6
8	1L3046	WASHER	8
9	6K6655	BELCRANK ASSEM	1
10	6F3890	SPACER-----(.50" Long)	1
11	6K1841	SPACER-----(.75" Long)	1
12	6K1267	SHAFT ASSEM	1
13	S509	BOLT	1
14	3B4506	LOCKWASHER	2
15	S175	PIN	6
16	3B4617	COTTER PIN	6
17	6F7010	END	1
18	7B9309	ROD	1
19	6K4442	BALL JOINT ASSEM	2
20	1B4430	NUT	3
21	6K2612	ROD	2
22	1B4205	NUT	2
23	S1595	BOLT	2
24	7K7821	BRACKET ASSEM	2
25	1F748	NUT----- (Weld)	1
26	6K2897	ROD	2
27	6K2611	ROD	1
28	9K1106	LEVER	1
29	1B8706	KEY	2
C 30	S1590	BOLT	1
C 31	1D4717	NUT	1
32	6K2647	BELCRANK ASSEM	1
33	6K2651	SHAFT	1
34	6K2463	LEVER ASSEM	1
35	L478	ROD	1
36	5B9079	NUT	1
37	8B8679	SPACER	1
37	S1591	BOLT	1

C INDICATES CHANGE



REF. NO.	PART NUMBER	DESCRIPTION	QTY
1	51621	BOLT	2
2	384508	LOCKWASHER	6
3	6K2555	BRACKET ASSEM.	1
4	5K2294	BEARING	2
5	7K1383	LEVER	1
6	L1170	HANDLE	1
7	6K647	BEARING	6
8	1L3046	WASHER	8
9	6K6655	BELLCRANK ASSEM.	1
10	6F3890	SPACER	1
11	6K1841	SPACER	1
12	6K1267	SHAFT ASSEM.	1
13	5509	BOLT	1
14	384506	LOCKWASHER	1
15	5175	PIN	6
16	384617	COTTER PIN	6
17	6F7010	END	1
18	7B9309	ROD	1
19	6K4442	BALLJOINT ASSEM.	2
20	1B4430	NUT	3
21	6K2612	ROD	1
22	1B4205	NUT	2
23	51595	BOLT	2
24	7K7821	BRACKET ASSEM.	1
25	1F748	NUT	2
26	6K2611	ROD	1
27	6K2897	ROD	1
28	9K1106	LEVER	1
29	1B8706	KEY	1
30	51591	BOLT	1
31	6K2647	BELLCRANK ASSEM.	1
32	6K2651	SHAFT	1

C INDICATES CHANGE

140405

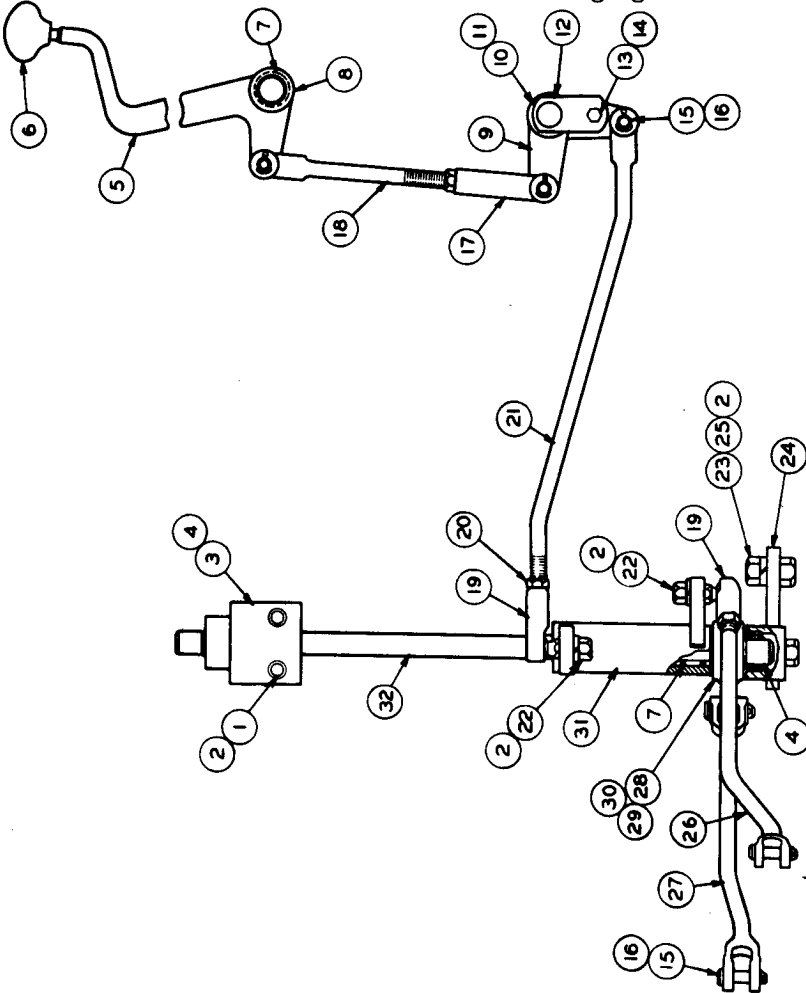

5K6271 HAND CONTROL GROUP—Front  
 Part of 5K6273, 5K6269, 3P7543 and 5K9838 Arrangements listed on Pages 148, 148A, 148D and 149

6J1165 CYLINDER GROUP—R.H. 5" Bore x 14.10" Stroke  
 6J1166 CYLINDER GROUP—L.H. 5" Bore x 14.10" Stroke  
 Part of 6K1096 Multi-Purpose Bucket Arrangement listed on Page 202A

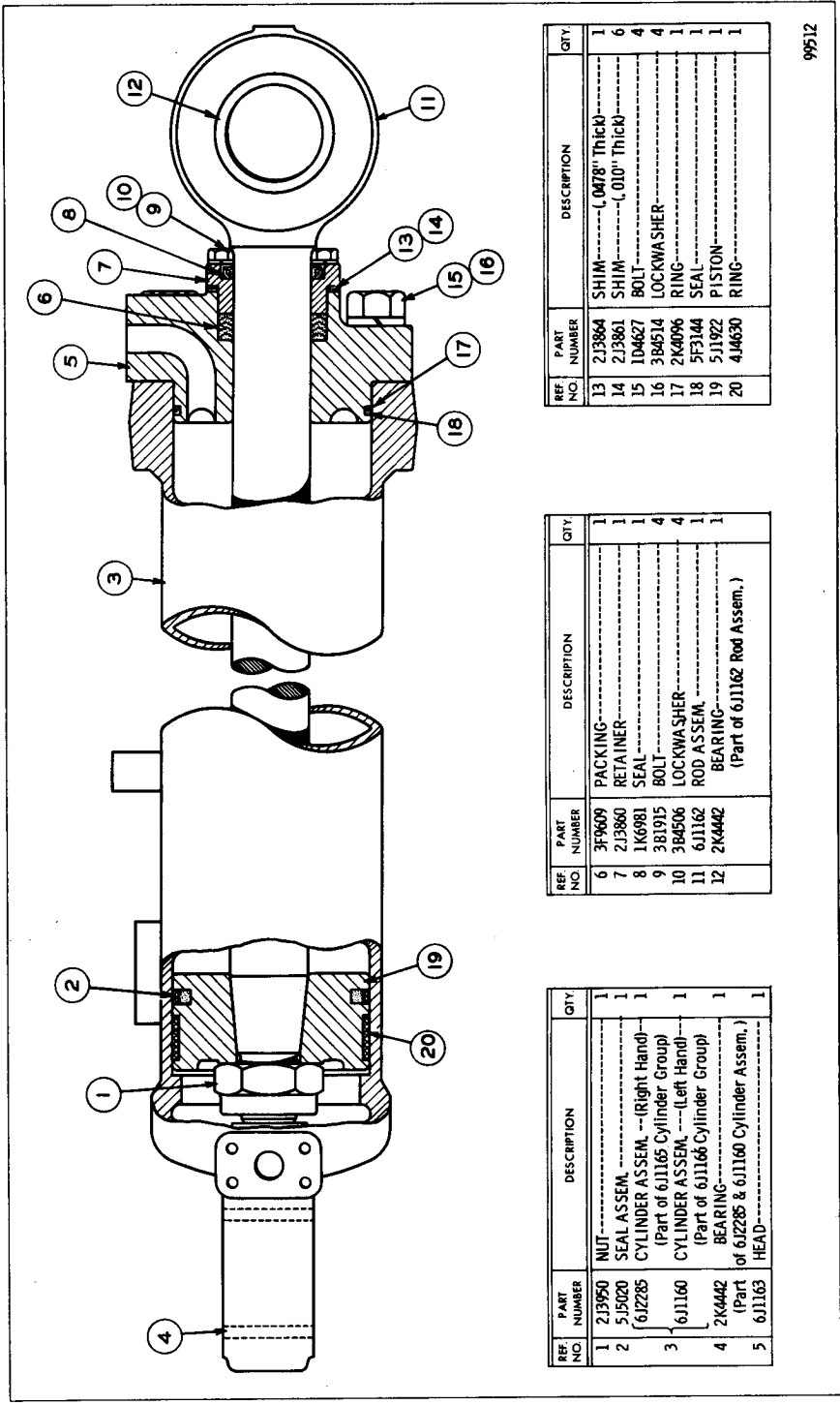

REF. NO.	PART NUMBER	DESCRIPTION	QTY.
1	213950	NUT	1
2	515020	SEAL ASSEM. --- (Right Hand)	1
3	6J2285	CYLINDER ASSEM. --- (Cylinder Group)	1
	6J1160	CYLINDER ASSEM. --- (Left Hand)	1
4	2K4442	BEARING--- (Part of 6J2285 & 6J1160 Cylinder Assem.)	1
5	6J1163	HEAD	1

REF. NO.	PART NUMBER	DESCRIPTION	QTY.
6	3F9609	PACKING	1
7	213960	RETAINER	1
8	1K6981	SEAL	1
9	3B1915	BOLT	4
10	3B4506	LOCKWASHER	4
11	6J1162	ROD ASSEM.	1
12	2K4442	BEARING--- (Part of 6J1162 Rod Assem.)	1

REF. NO.	PART NUMBER	DESCRIPTION	QTY.
13	213964	SHIM--- (.0478" Thick)	1
14	213961	SHIM--- (.010" Thick)	6
15	1D4627	BOLT	4
16	3B4514	LOCKWASHER	4
17	2K4096	RING	1
18	5F3144	SEAL	1
19	5J1922	PISTON	1
20	4J4630	RING	1

7J9375 LIFT CYLINDER GROUP—R.H. (7K9385 N/S) (Chg. 0-2) 6.50" Bore x 36.70" Stroke

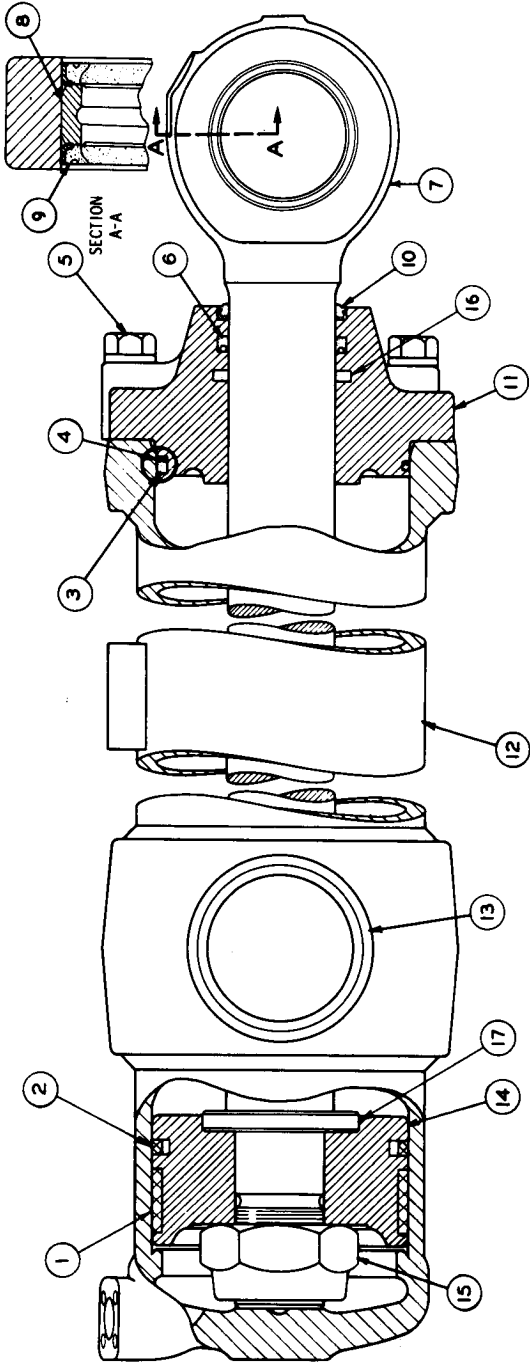

REF. NO.	PART NUMBER	DESCRIPTION	QTY
1	7J1938	RING-----	1
2	5J4991	SEAL ASSEM.-----	1
3	2K4472	SEAL-----	1
4	2K7743	WASHER-----	1
5	1D4610	BOLT-----	6
	5H1504	WASHER-----	6

6	5J8275	SEAL-----	1
7	7J9373	ROD ASSEM.-----	1
8	7J9345	BEARING-----	1
9	5P66	SEAL-----	2
10	1J3540	SEAL-----	1
11	6J7829	HEAD-----	1

12	7J9641	CYLINDER ASSEM.-----	1
13	5J5370	BEARING-----	2
14	7J1932	PISTON-----	1
15	5J3488	NUT-----	1
16	6J6553	SEAL-----	1
17	7J1937	WASHER-----	1

▲ NOT PART OF 7J9375 CYLINDER GROUP

147778

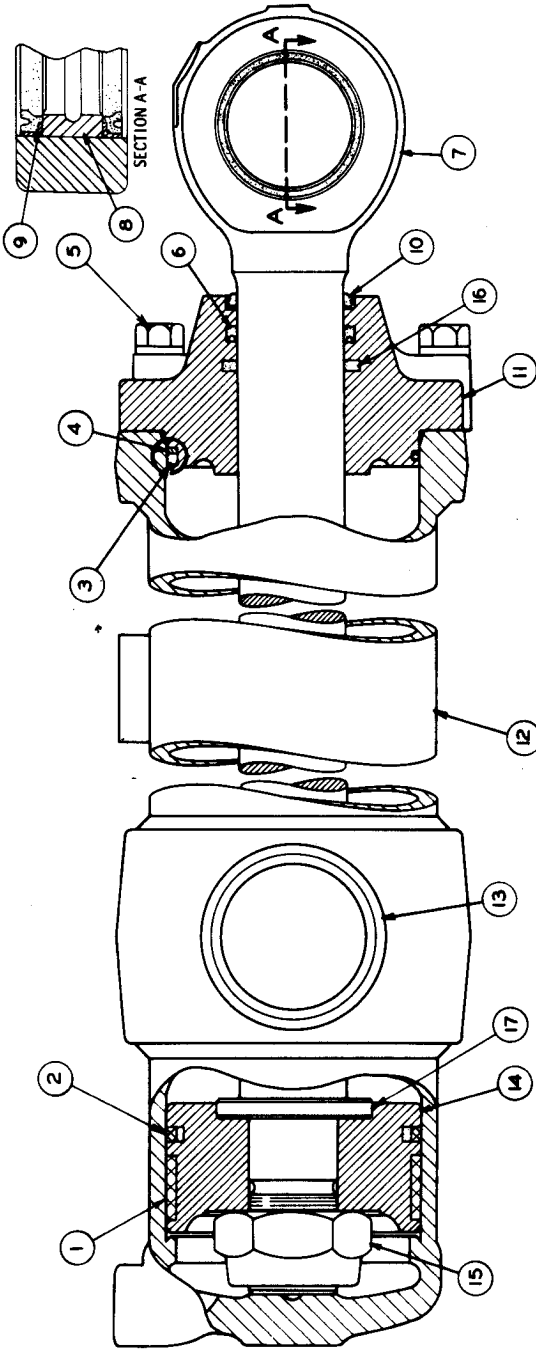

REF NO	PART NUMBER	DESCRIPTION	QTY
1	7J1938	RING	1
2	51A901	SEAL ASSEM.	1
3	2K4472	SEAL	1
4	2K4473	WASHER	1
5	1D4610	BOLT	6
5	5H1504	WASHER	6

6	5J8275	SEAL	1
7	7J9373	ROD ASSEM.	1
8	7J9345	BEARING	1
9	5P66	SEAL	2
10	1J3540	SEAL	1
11	6J7829	HEAD	1

12	7J9642	CYLINDER ASSEM.	1
13	5J5370	BEARING	2
14	7J1932	PISTON	1
15	5J3488	NUT	1
16	6J6553	SEAL	1
17	7J1937	WASHER	1

▲ NOT PART OF 7J9376 CYLINDER GROUP

147786

7J9376 LIFT CYLINDER GROUP—L.H. (7K9386 N/S) (Chg. 0-2) 6.50" Bore x 36.70" Stroke

7J9659 LIFT CYLINDER GROUP—R.H. (7K9391 N/S) (Chg. 0) 6.5" Bore x 36.66" Stroke  
 Part of 6K5440 Hydraulic Arrangement listed on Page 150  
 AN ATTACHMENT

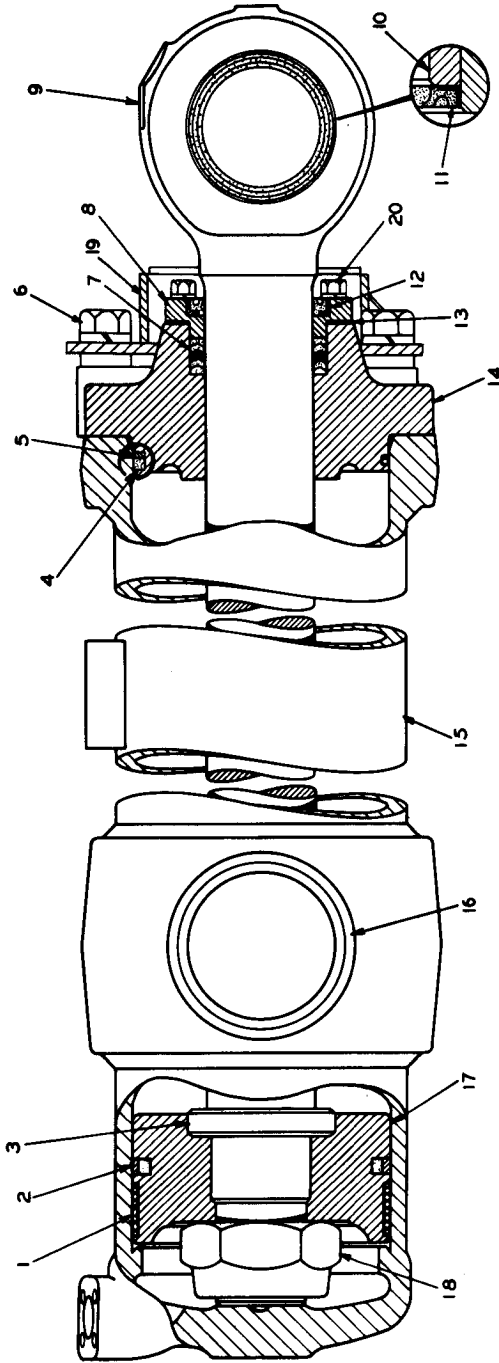

REF. NO.	PART NUMBER	DESCRIPTION	QTY
1	7J1938	RING-----	1
2	5J4991	SEAL ASSEM.-----	2
3	7J1937	WASHER-----	1
4	2K4472	SEAL-----	1
5	2K4473	WASHER-----	1
6	3B2968	BOLT-----	6
6	5H1504	WASHER-----	12
7	5F3498	PACKING-----	1

8	2J491	RETAINER-----	1
9	7J9373	ROD ASSEM.-----	1
10	7J9345	BEARING-----	1
11	5P66	SEAL-----	2
12	7J8274	SEAL-----	1
13	5F3500	SHIM-----	6
14	7J486	HEAD-----	1
15	7J9641	CYLINDER ASSEM. --(Right Hand)---	1
16	5J5370	BEARING-----	2

17	7J1932	PISTON-----	1
18	5J3488	NUT-----	1
19	7J4577	SHIELD ASSEM. --- (R. H.) ---	1
19	7J4578	SHIELD ASSEM. --- (L. H.) ---	1
20	5L591	BOLT-----	4
20	3B4506	LOCKWASHER-----	4

▲ NOT PART OF 7J9659 CYLINDER GROUP 147779

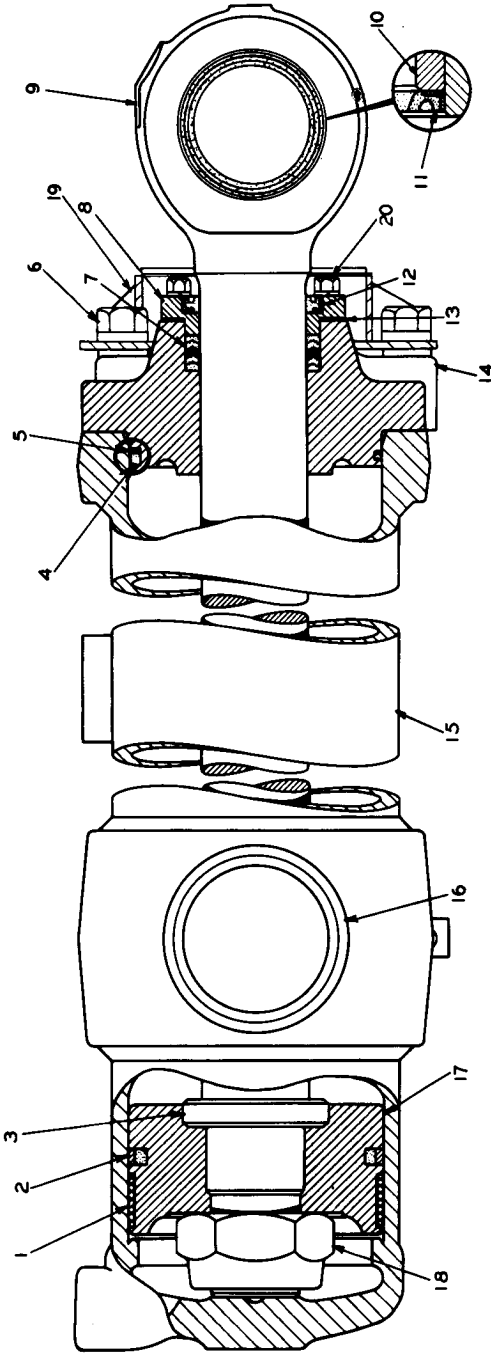

REF. NO.	PART NUMBER	DESCRIPTION	QTY
1	7J1938	RING	1
2	5J4901	SEAL ASSEM.	1
3	7J1937	WASHER	1
4	2K4472	SEAL	1
5	2K4473	WASHER	1
6	3B2968	BOLT	6
7	5H1504	WASHER	12
	7F5498	PACKING	1

8	2J491	RETAINER	1
9	7J9373	ROD ASSEM.	1
10	7J9345	BEARING	1
11	5P66	SEAL	2
12	7J8274	SEAL	1
13	5F3500	SHIM	6
14	7J486	HEAD	1
15	7J9642	CYLINDER ASSEM.---(Left Hand)	1
16	5J5370	BEARING	2

17	7J1932	PISTON	1
18	5J3488	NUT	1
19	7J4577	SHIELD ASSEM.---(R. H.)	1
	7J4578	SHIELD ASSEM.---(L. H.)	1
	S1591	BOLT	4
	3B4506	LOCKWASHER	4

▲ NOT PART OF 7J9660 CYLINDER GROUP 14778

7J9660 LIFT CYLINDER GROUP—L.H. (7K9396 N/S) (Chg. 0) 6.50" Bore x 36.66" Stroke  
 Part of 6K5440 Hydraulic Arrangement listed on Page 150  
 AN ATTACHMENT

7J9645 TILT CYLINDER GROUP—R.H. (7K9387 N/S) (Chg. 0 & 1) 6.00" Bore x 27.40" Stroke  
 Serial No. 11K5051 to 11K5353 inclusive

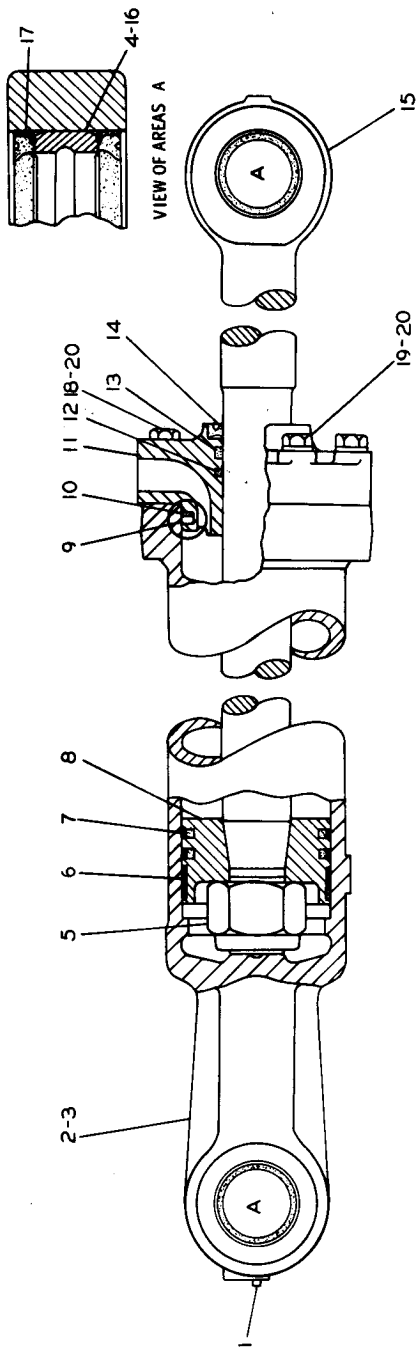

13	5J18275	SEAL	1
14	1J13540	SEAL	1
15	7J19377	ROD ASSEM. (Includes)	1
16	7J19346	BEARING	1
17	5P64	SEAL	4
18	3B2968	BOLT	2
19	1D4610	BOLT	6
20	5H1504	WASHER	8

6	1J708	RING	1
7	5J4989	SEAL ASSEM.	2
8	5J5056	PISTON	1
9	5H3252	SEAL	1
10	2K3258	RING	1
11	6J7591	HEAD	1
12	6J6553	SEAL	1

REF NO.	PART NUMBER	DESCRIPTION	QTY
1	12B7408	PLUG	1
2	7J9643	CYLINDER ASSEM. (Includes)	1
3	1F748	NUT	1
4	7J9346	BEARING	1
5	3J6899	NUT	1

▲ NOT PART OF 7J9645 CYLINDER GROUP

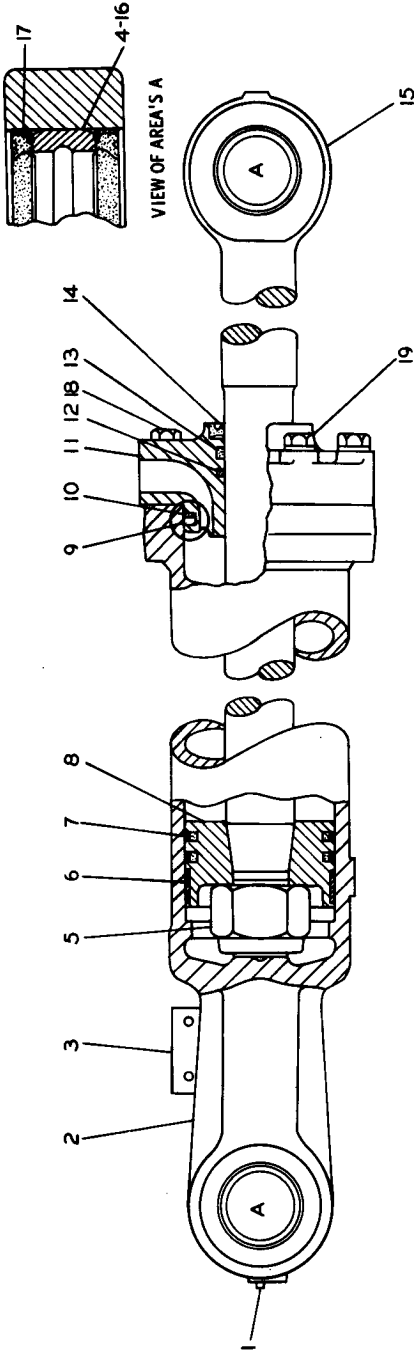

13	5J8275	SEAL	1
14	1J3540	SEAL	1
15	7J9377	ROD ASSEM.	1
16	7J9346	BEARING	1
17	5P64	BOLT	4
18	382968	BOLT	2
19	1D4610	WASHER	6
	3H1504	WASHER	8
	GMG02349	FORM	1

(Instructions for Installing Tilt Cylinder Lines and Bracket)

6	1J708	RING	1
7	5J4989	SEAL ASSEM.	2
8	5J5056	PISTON	1
9	5H3252	SEAL	1
10	2K3258	RING	1
11	9J4991	HEAD	1
12	6J6553	SEAL	1

REF. NO.	PART NUMBER	DESCRIPTION	QTY
1	2B7408	PLUG	1
2	9J668	CYLINDER ASSEM. --- (R. H. )	1
3	6J2653	LUG	1
3	9J665	PLATE	1
4	7J9346	BEARING	1
5	3J6899	NUT	1

203178

▲ NOT PART OF 9J672 CYLINDER GROUP

9J672 TILT CYLINDER GROUP—R.H. (3P6137 N/S) (Chg. 0-2) 6.00" Bore x 27.40" Stroke  
 Part of 6KS440 Hydraulic Arrangement listed on Page 150  
 AN ATTACHMENT



7J9646 TILT CYLINDER GROUP—L.H. (7K9388 N/S) (Chg. 0) 6.00" Bore x 27.40" Stroke  
 Serial No. 11K5051 to 11K5353 inclusive

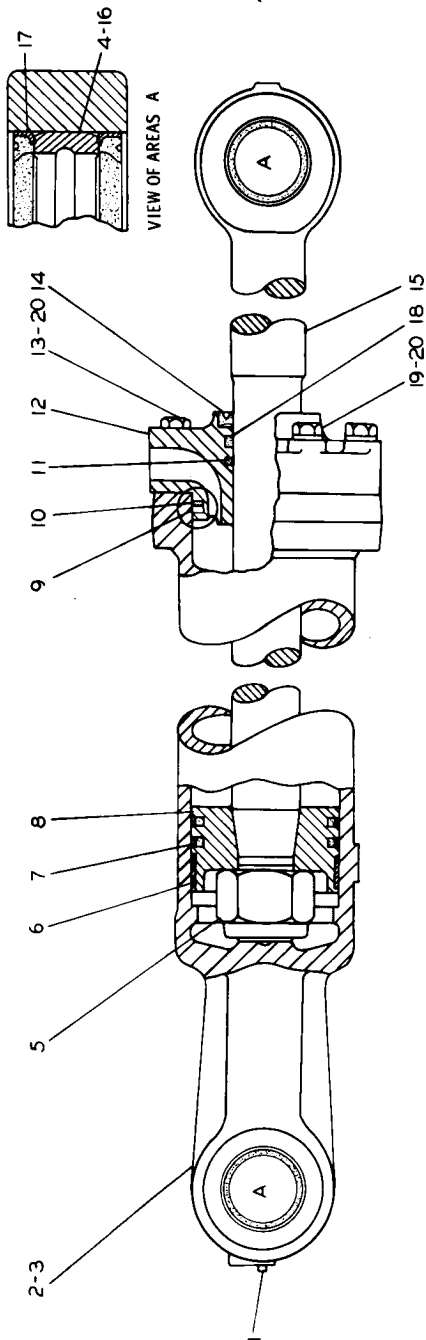

REF. NO.	PART NUMBER	DESCRIPTION	QTY
1	287408	PLUG-----	1
2	7J9644	CYLINDER ASSEM. (Includes)	1
3	1F748	NUT-----	1
4	7J9346	BEARING-----	1
5	3J6899	NUT-----	1
6	1J708	RING-----	1

7	5J4989	SEAL ASSEM.	2
8	5J5056	PISTON-----	1
9	5H3252	SEAL-----	1
10	2K3258	RING-----	1
11	6J6553	SEAL-----	1
12	6J7591	HEAD-----	1
13	3B2968	BOLT-----	2

14	1J3540	SEAL-----	1
15	7J9648	ROD ASSEM. (Includes)	1
16	7J9346	BEARING-----	4
17	5P64	SEAL-----	4
18	5J8275	SEAL-----	1
19	1D4610	BOLT-----	6
20	5H1504	WASHER-----	8

▲ NOT PART OF 7J9646 CYLINDER GROUP

147782

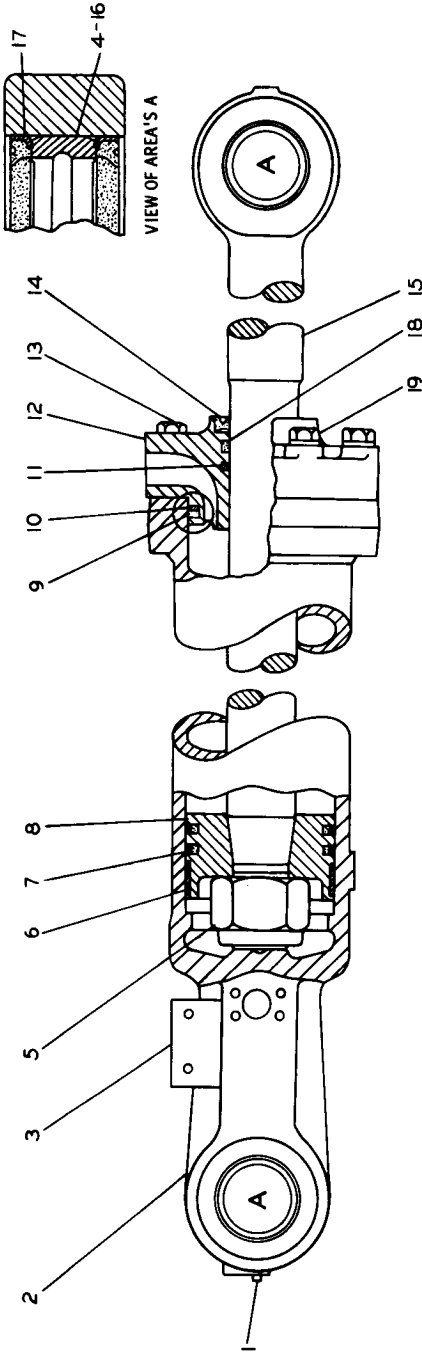

REF NO.	PART NUMBER	DESCRIPTION	QTY
1	2B7408	PLUG-----	1
2	9J669	CYLINDER ASSEM.-----(L.H.)----	1
3	9J665	PLATE-----	1
4	7J9346	BEARING-----	1
5	3J6899	NUT-----	1
6	1J708	RING-----	1

7	5J4989	SEAL ASSEM.-----	2
8	5J5056	PISTON-----	1
9	5H3252	SEAL-----	1
10	2K3258	RING-----	1
11	6J6553	SEAL-----	1
12	9J4991	HEAD-----	1
13	3B2968	BOLT-----	2

14	1J3540	SEAL-----	1
15	7J9648	ROD ASSEM.----- (Includes) BEARING-----	1
16	7J9346	BEARING-----	4
17	5P64	SEAL-----	1
18	5J8275	SEAL-----	1
19	1D4610	BOLT-----	6
	5H1504	WASHER-----	8
	5M602349	FORM-----	1
(Instructions for Installing Tilt Cylinder Lines and Bracket)			

▲ NOT PART OF 9J673 CYLINDER GROUP

203180

9J673 TILT CYLINDER GROUP—L.H. (3F6138 N/S) (Chg. 0-2) 6.00" Bore x 27.40" Stroke  
Serial No. 11K5354—Up

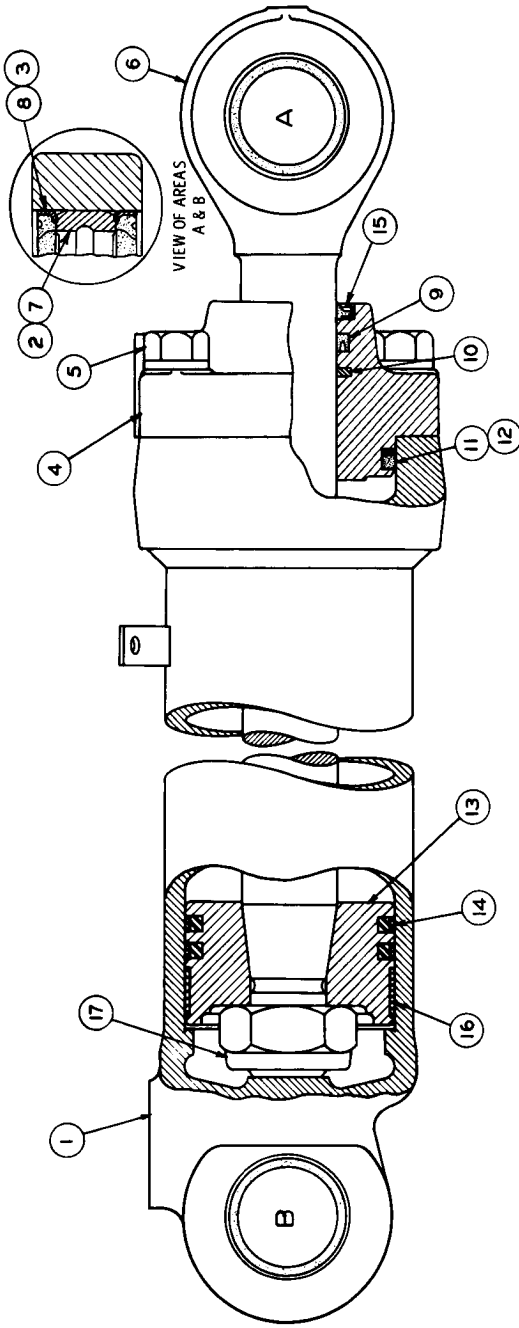

REF. NO.	PART NUMBER	DESCRIPTION	QTY
1	8J5763	CYLINDER ASSEM.	1
2	7J9731	BEARING	1
3	5P65	SEAL	2
4	9J5612	HEAD	1
5	8H5772	BOLT	4
6	9M2828	WASHER	4

6	8J5766	ROD ASSEM.	1
7	7J9732	BEARING	1
8	5P65	SEAL	2
9	5J964	SEAL	1
10	5J3620	SEAL	1

11	2H9247	SEAL	1
12	2K2961	RING	1
13	5J4545	PISTON	1
14	5J4988	SEAL ASSEM.	2
15	1K6982	SEAL	1
16	4J4606	RING	1
17	2J564	NUT	1

▲ NOT PART OF 8J5761 GROUP

150034

8J5761 CYLINDER GROUP (9K3177 N/S) (Change 0)—5.50" Bore x 31.70" Stroke—2 Required  
 Part of 7K8741, 1V8152 and 1V8153 Demolition Bucket Arrangements listed on Pages 208 and 208A  
 AN ATTACHMENT

6J7056 HYDRAULIC CYLINDER GROUP—5.50" Bore x 31.70" Stroke—2 Required  
 Part of 7K8741 Demolition Bucket Arrangement listed on Page 208. Only separate parts serviced  
 When complete Group is required order 8J5761, shown on Page 136, plus 4—5P65 Seals. AN ATTACHMENT

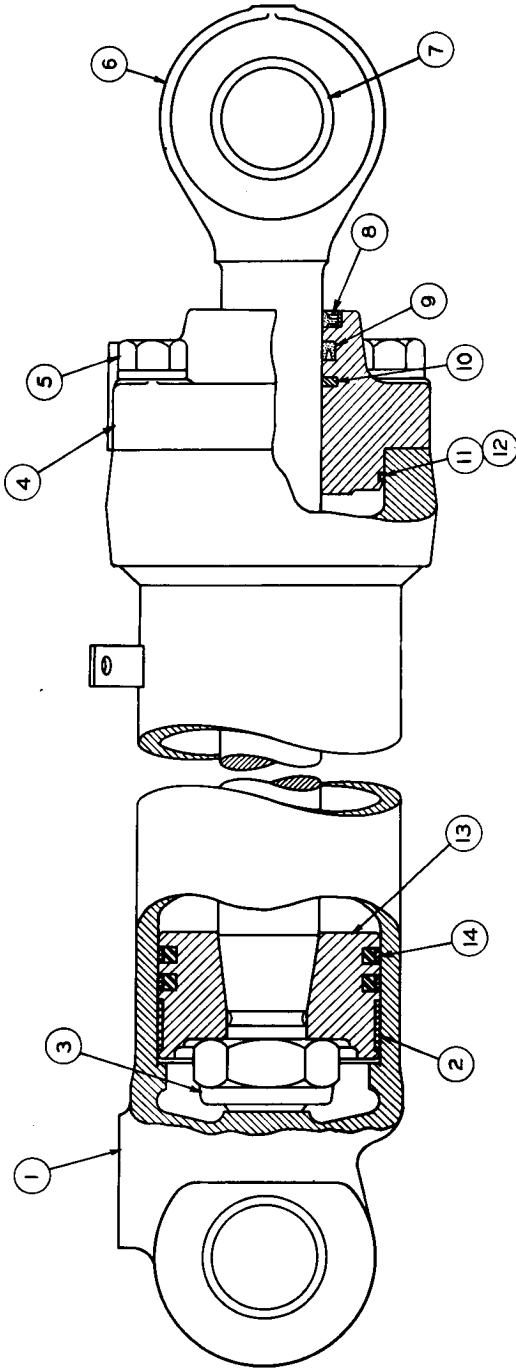

REF NO.	PART NUMBER	DESCRIPTION	QTY
1	6J7055	CYLINDER ASSEM.	1
	4K300	BEARING (Part of 6J7055 Cylinder Assem.)	1
2	4J4606	RING (Part of 6J7055 Cylinder Assem.)	4
3	2J564	NUT	1
4	6J7959	HEAD	1
5	8H5772	BOLT	4
	9M2828	WASHER	4

REF NO.	PART NUMBER	DESCRIPTION	QTY
6	6J7110	ROD ASSEM.	1
7	4K300	BEARING (Part of 6J7110 Rod Assem.)	1
8	1K6982	SEAL	1
9	5J964	SEAL	1
10	5J3620	SEAL	1

REF NO.	PART NUMBER	DESCRIPTION	QTY
11	2H9247	SEAL	1
12	2K2961	RING	1
13	5J4545	PISTON	1
14	5J4988	SEAL ASSEM.	2

123248

CATERPILLAR 977L TRAXCAVATOR

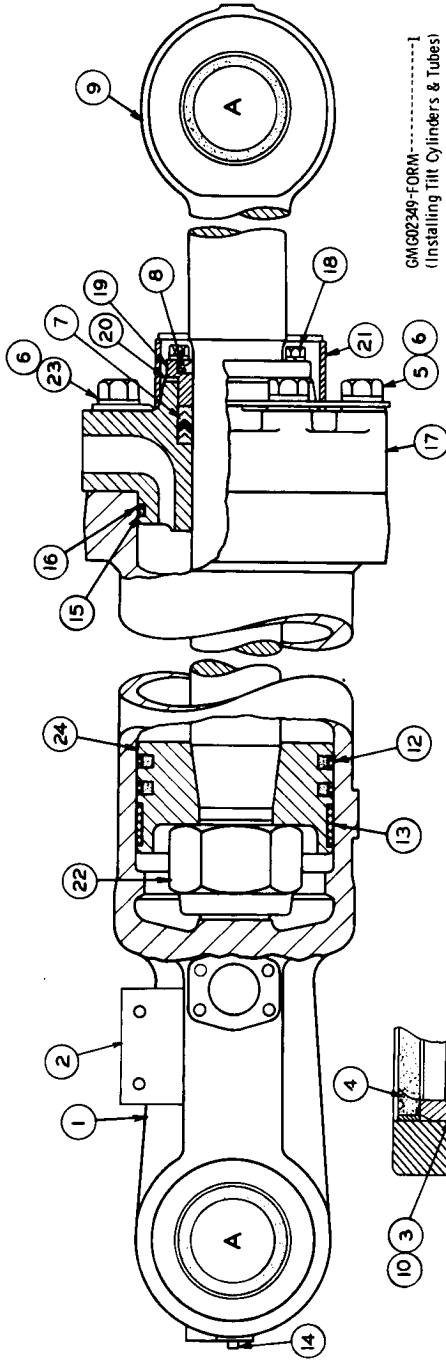

GM602349-FORM-----1  
(Installing Tilt Cylinders & Tubes)

15	5H3252	SEAL	1
16	2K3258	RING	1
17	7J491	HEAD	1
18	S1591	BOLT	4
18	384506	LOCKWASHER	4
19	2J491	RETAINER	1
20	5F3500	SHIM	6
21	7J4579	SHIELD ASSEM.---(R. H.)	1
22	7J4580	SHIELD ASSEM.---(L. H.)	1
23	3J6899	NUT	1
23	1D4612	BOLT	1
24	5J5056	PISTON	2

5	7F3227	BOLT	6
6	5H1504	WASHER	16
7	5F3498	PACKING	1
8	7J8274	SEAL	1
9	7J9648	ROD ASSEM.	1
10	7J9346	BEARING	1
12	5J4989	SEAL ASSEM.	2
13	1J708	RING	1
14	2B7408	PLUG	1

REF. NO.	PART NUMBER	DESCRIPTION	QTY
1	9J669	CYLINDER ASSEM.---(L. H.)	1
2	9J665	PLATE	1
3	7J9346	BEARING	1
4	5P64	SEAL	4

▲ NOT PART OF 9J670 CYLINDER GROUP

203177

9J670 TILT CYLINDER GROUP—L.H. (3P6140 N/S) (Chg. 0 & 1) 6.00" Bore x 27.40" Stroke  
Part of 6K5440 Hydraulic Arrangement listed on Page 150  
AN ATTACHMENT

7J9668 TILT CYLINDER GROUP—L.H. (7J488 N/S) (Chg. 0) 6.00" Bore x 27.36" Stroke  
 Part of 6K540 Hydraulic Arrangement listed on Page 150. Only separate parts serviced  
 When complete Group is required, order 9J670 Cylinder Group plus 4—5P64 Seal. AN ATTACHMENT

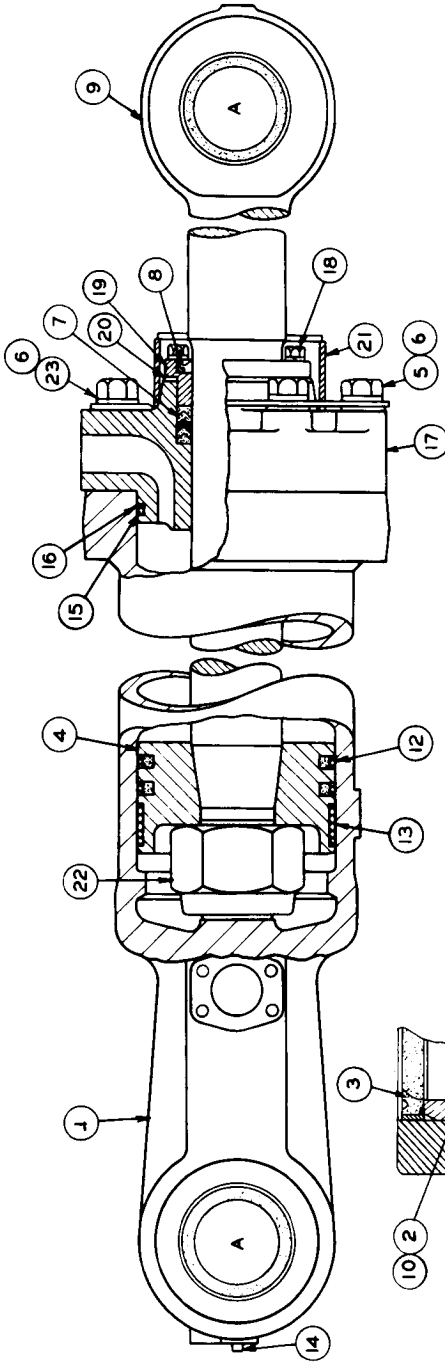

15	5H3252	SEAL	1
16	2K3258	RING	1
17	7L491	HEAD	1
18	5L591	BOLT	4
19	384506	LOCKWASHER	4
20	2J491	RETAINER	6
21	5F3500	SHIM	1
22	7J4579	SHIELD ASSEM. --- (R. H.)	1
23	7J4580	SHIELD ASSEM. --- (L. H.)	1
	3J6899	NUT	1
	1D4612	BOLT	2

4	5J5056	PISTON	1
5	7F5227	BOLT	6
6	5H1504	WASHER	16
7	5F3498	PACKING	1
8	7J8274	SEAL	1
9	7J9648	ROD ASSEM. (Includes)	1
10	7J9346	BEARING	1
12	5J4989	SEAL ASSEM.	2
13	1J708	RING	1
14	2B7408	PLUG	1

REF. NO.	PART NUMBER	DESCRIPTION	QTY
1	7J9644	CYLINDER ASSEM. (Includes)	1
2	7J9346	BEARING	1
3	5P64	SEAL	4

▲ NOT PART OF 7J9668 CYLINDER GROUP

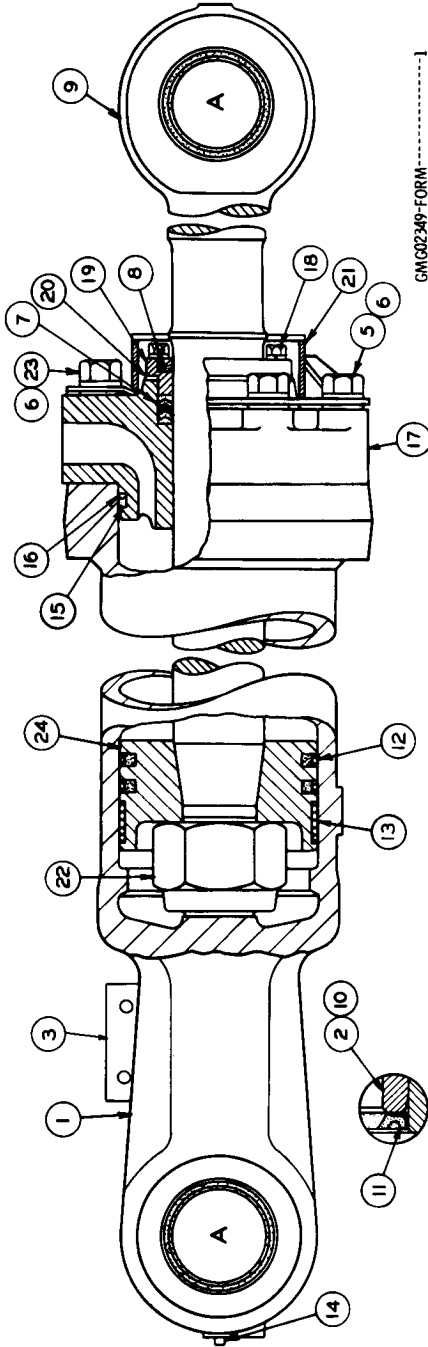

GM02349-FORM-----1  
(Installing Tilt Cylinders & Tubes)

REF. NO.	PART NUMBER	DESCRIPTION	QTY
1	9J668	CYLINDER ASSEM.---(R.H.)---	1
2	6J2653	LUG	1
3	9J665	PLATE	1
5	7F5227	BOLT	6
6	5H1504	WASHER	16

7	5F3498	PACKING	1
8	7J8274	SEAL	1
9	7J9377	ROD ASSEM.	1
10	7J9346	BEARING	1
11	5P64	SEAL	4
12	5J4989	SEAL ASSEM.	2
13	1J708	RING	2
14	2B7408	PLUG	1
15	5H3252	SEAL	1
16	2K3258	RING	1

17	7J491	HEAD	1
18	S1591	BOLT	4
19	3B4506	LOCKWASHER	4
20	2J491	RETAINER	1
20	5F3500	SHIM	6
21	7J4580	SHIELD ASSEM.---(L.H.)---	1
21	7J4579	SHIELD ASSEM.---(R.H.)---	1
22	3J6899	NUT	1
23	1D4612	BOLT	2
24	5J5056	PISTON	1

▲ NOT PART OF 9J671 CYLINDER GROUP 203179

9J671 TILT CYLINDER GROUP—R.H. (3P6139 N/S) (Chg. 0-1) 6.00" Bore x 27.40" Stroke  
Part of 6K5440 Hydraulic Arrangement listed on Page 150  
AN ATTACHMENT

7J9657 TILT CYLINDER GROUP—R.H. (7K9389 N/S) (Chg. 0 & 1) 6.00" Bore x 27.40" Stroke  
 Part of 6K5440 Hydraulic Arrangement listed on Page 150  
 Only separate parts serviced. When complete Group is required, order 9J671 Cylinder Group plus 4—5P65 Seal  
 AN ATTACHMENT

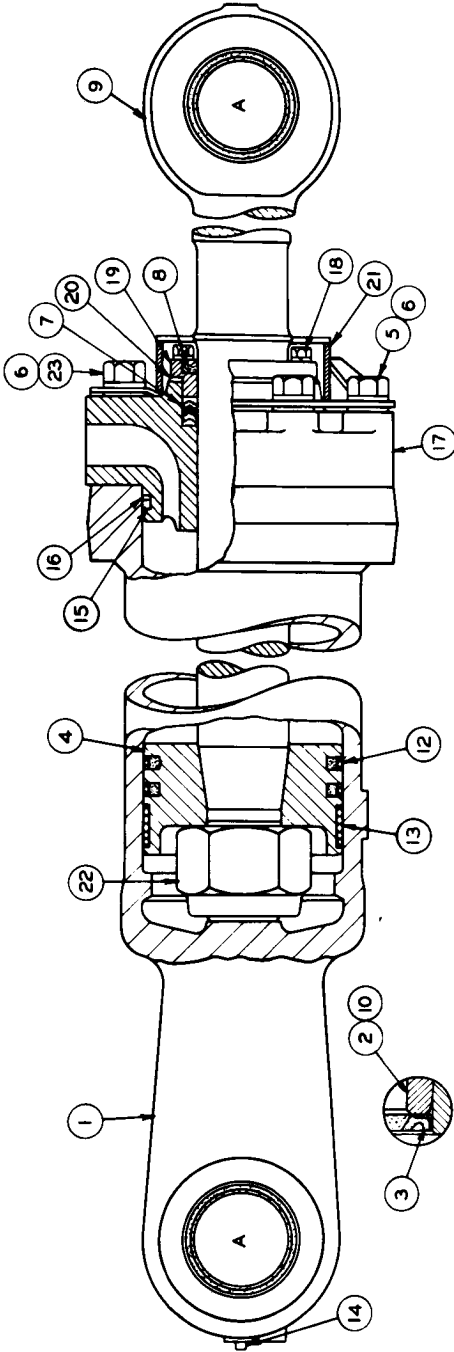

VIEW OF AREAS A

REF NO	PART NUMBER	DESCRIPTION	QTY
1	7J9643	CYLINDER ASSEM. (includes)	1
1	1F748	NUT	1
2	7J9346	BEARING	1
3	5P64	SEAL	4
4	5J5056	PISTON	1
5	7F5227	BOLT	6
6	15H1504	WASHER	16

7	5F3498	PACKING	1
8	7J8274	SEAL	1
9	7J9377	ROD ASSEM. (includes)	1
10	7J9346	BEARING	1
12	5J4989	SEAL ASSEM.	2
13	1J708	RING	1
14	2B7408	PLUG	1
15	5H3252	SEAL	1
16	2K3258	RING	1

17	7J491	HEAD	1
18	5L591	BOLT	4
19	3B4506	LOCKWASHER	4
19	2J491	RETAINER	1
20	5F3500	SHIM	6
21	7J4580	SHIELD ASSEM. (L.H.)	1
22	7J4579	SHIELD ASSEM. (R.H.)	1
22	3J6899	NUT	1
23	1D4612	BOLT	2

▲ NOT PART OF 7J9657 CYLINDER GROUP



5J9893 SIDE DUMP CYLINDER GROUP  
 Part of 6K707 Side Dump Bucket Arrangement listed on Page 206  
 Only separate parts serviced. When complete Group is required order 9K3175 shown on Page 138  
 AN ATTACHMENT

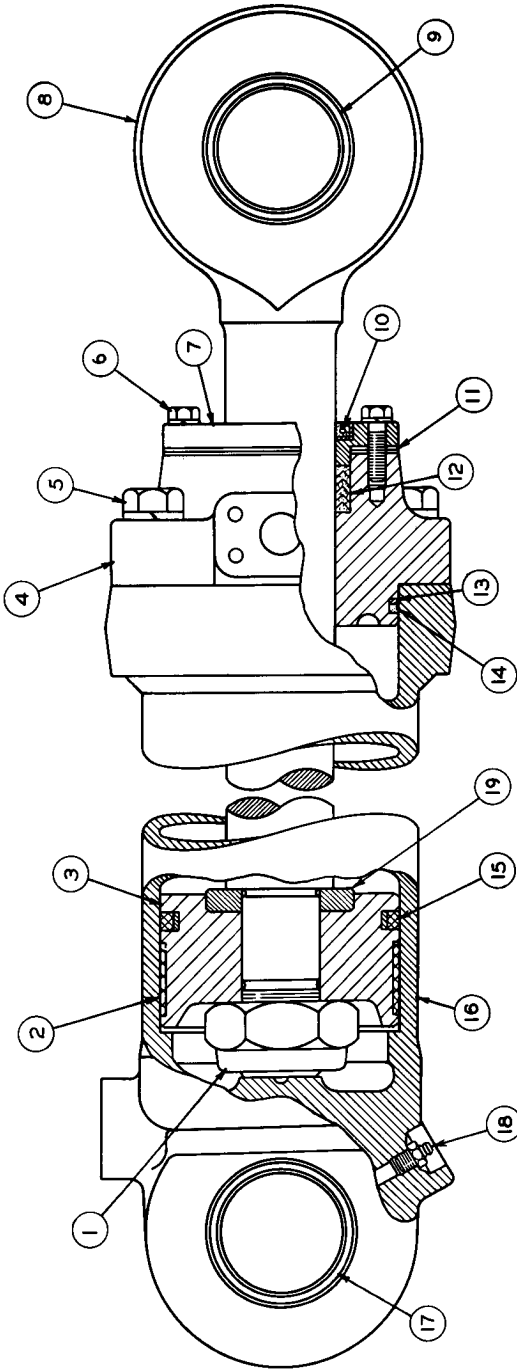

REF. NO.	PART NUMBER	DESCRIPTION	QTY.
1	5J5731	NUT-----	1
2	4J3420	RING-----	1
3	7J2466	PISTON-----	1
4	5J9883	HEAD-----	1
5	1D4608	BOLT-----	4
	3B4512	LOCKWASHER-----	4
6	3B1915	BOLT-----	4
	3B4506	LOCKWASHER-----	4

7	5J2630	RETAINER-----	1
8	7J2469	ROD ASSEM.-----	1
9	2K4507	BEARING-----	1
10	4J3515	SEAL-----	1
11	5J2629	SHIM-----	6
12	2K4434	PACKING-----	1

13	2K4069	RING-----	1
14	5F3144	SEAL-----	1
15	5J5020	SEAL ASSEM.-----	1
16	5J9892	CYLINDER ASSEM.-----	1
17	5J9889	BEARING-----	1
18	3B8489	FITTING-----	1
19	7J2467	WASHER-----	1

139930

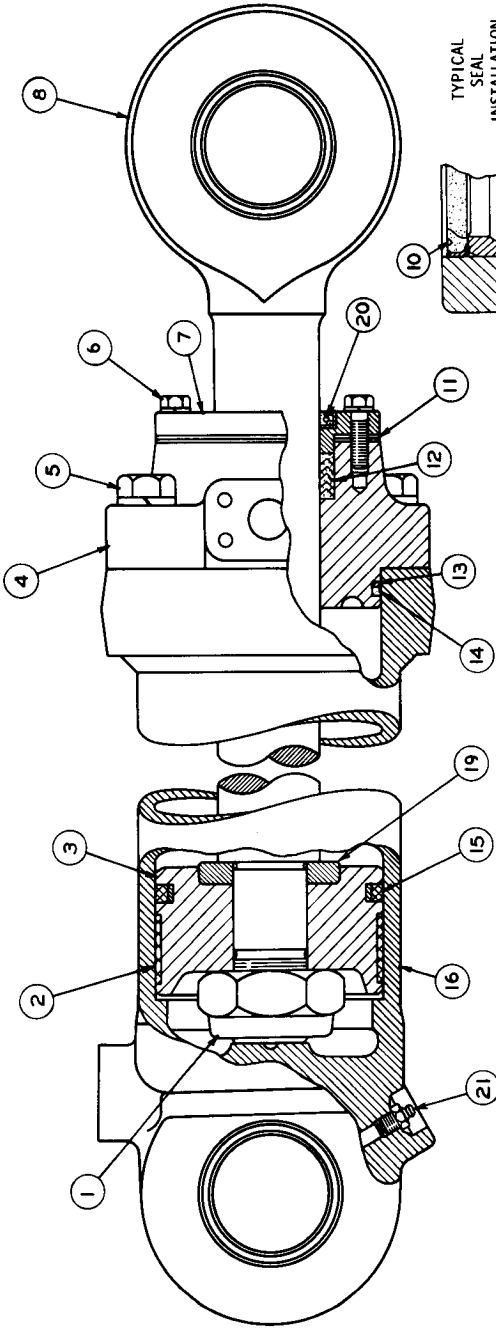

REF NO	PART NUMBER	DESCRIPTION	QTY
1	5J5731	NUT	1
2	4J3420	RING	1
3	7J2466	PISTON	1
4	5J9883	HEAD	1
5	1D4608	BOLT	4
6	3B4512	LOCKWASHER	4
	3B1915	ROLT	4
	3B4506	LOCKWASHER	4

7	512630	RETAINER	1
8	8J5753	ROD ASSEM	1
9	7J9344	BEARING	1
▲ 10	5P65	SEAL	4
11	5J2629	SHIM	6
12	2K4434	PACKING	1
C 13	2K4096	RING	1
14	5F3144	SEAL	1
15	5J5020	SEAL ASSEM	1
16	8J5750	CYLINDER ASSEM	1
17	18J5778	BEARING	1

C INDICATES CHANGE

19	7J2467	WASHER	1
20	4J3515	SEAL	1
21	3B8489	FITTING	1

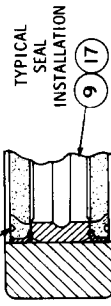

▲ NOT PART OF 8J5749 CYLINDER GROUP 149586

8J5749 CYLINDER GROUP (9K3175 N/S) (Chg. 0-4) 5.00" Bore x 23.31" Stroke  
 Part of 6K707 Side Dump Bucket Arrangement listed on Page 206  
 AN ATTACHMENT

6J4513 CYLINDER GROUP—5.00" Bore x 19.38" Stroke—2 Required

Part of 6K1009 Top Clamp Arrangement listed on Page 209  
 Only separate parts serviced. When complete Group is required order 9K3176 shown on Page 140  
 AN ATTACHMENT

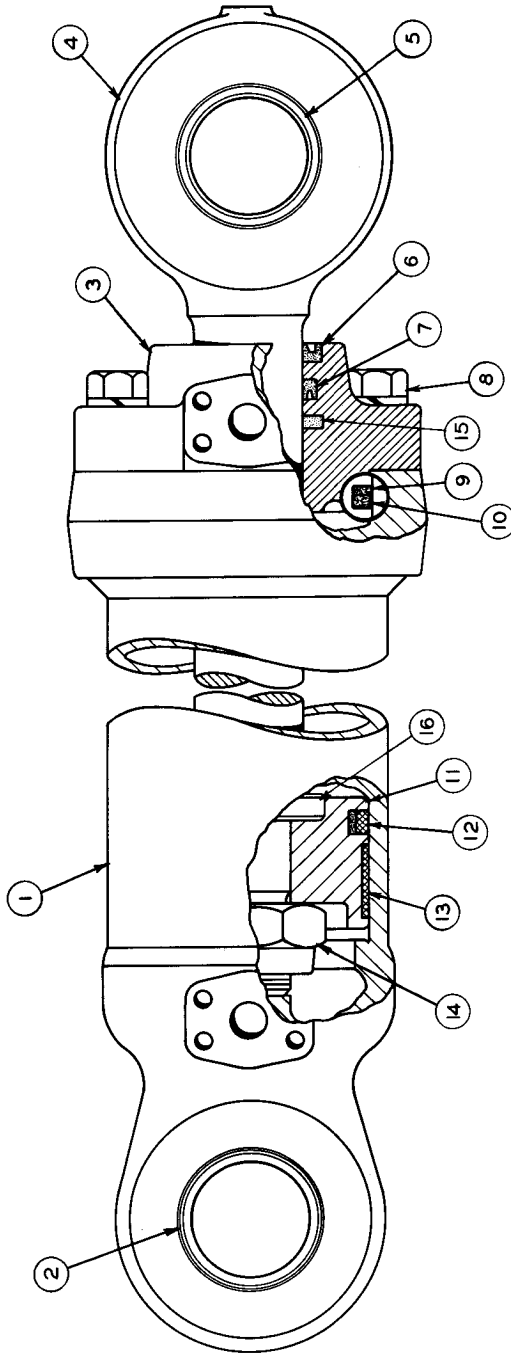

REF. NO.	PART NUMBER	DESCRIPTION	QTY
1	6J4517	CYLINDER ASSEM.	1
2	2K4507	BEARING (Part of 6J4517 Assem.)	1
3	7J2464	HEAD BEARING	1
4	7J2468	ROD ASSEM.	1
5	2K4507	BEARING (Part of 7J2468 Assem.)	1

REF. NO.	PART NUMBER	DESCRIPTION	QTY
6	4J3515	SEAL	1
7	5J8225	SEAL	1
8	1J04626	BOLT	4
9	3B4514	LOCKWASHER	4
9	2K4096	RING	1

REF. NO.	PART NUMBER	DESCRIPTION	QTY
10	5F3144	SEAL	1
11	7J2466	PISTON	1
12	5J5020	SEAL ASSEM.	1
13	4J3420	RING	1
14	5J5731	NUT	1
15	5J3616	SEAL	1
16	7J2467	WASHER	1

112/40

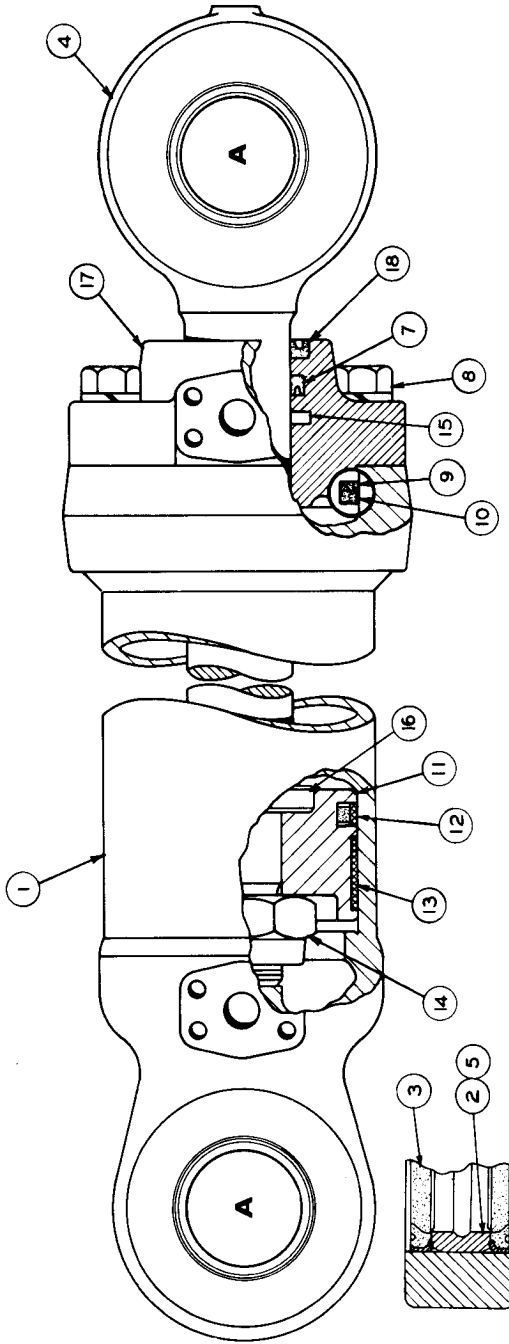

12	515020	SEAL ASSEM.....	1
13	413420	RING.....	1
14	515731	NUT.....	1
15	513616	SEAL.....	1
16	712467	WASHER.....	1
17	712464	HEAD.....	1
18	413515	SEAL.....	1

4	8J5759	ROD ASSEM..... (Includes)	1
5	719344	BEARING.....	1
7	518225	SEAL.....	1
8	104626	BOLT.....	1
8	384514	LOCKWASHER.....	4
9	2K4096	RING.....	4
10	5F3144	SEAL.....	1
11	712466	PISTON.....	1

REF NO.	PART NUMBER	DESCRIPTION	QTY
1	8J5756	CYLINDER ASSEM..... (Includes)	1
2	719344	BEARING.....	1
3	5P65	SEAL.....	4

▲ NOT PART OF 8J5755 CYLINDER GROUP 147781

▲

8J5755 CYLINDER GROUP (9K3176 N/S) (Chg. 0) 5.00" Bore x 19.38" Stroke—2 Required  
 Part of 6K1009 Top Clamp Arrangement listed on Page 209  
 AN ATTACHMENT

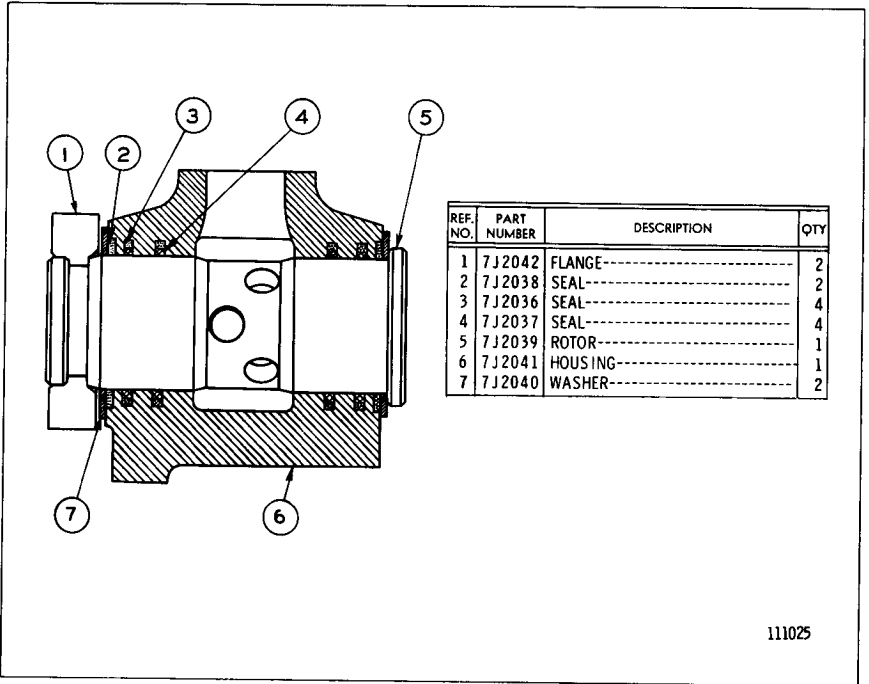

111025

7J2043 SWIVEL JOINT GROUP  
 Part of Tilt Cylinder Lines shown on Pages 144 and 146

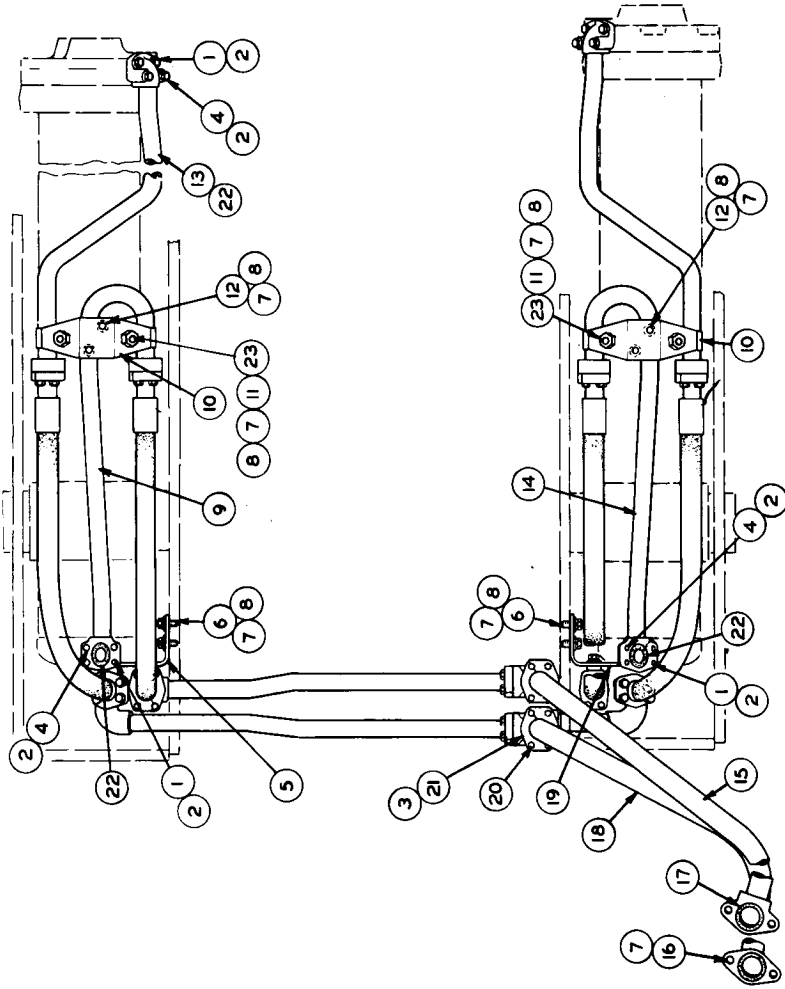

REF. NO.	PART NUMBER	DESCRIPTION	QTY
1	1A2029	BOLT	6
2	3B4506	LOCKWASHER	12
3	6J3600	SEAL	2
4	S1590	BOLT	6
5	6K492	BRACKET (L.H.)	1
6	7B3235	BOLT	6
7	3B4508	LOCKWASHER	20
8	4B4280	WASHER	22
9	6K1704	TUBE ASSEM.	1
10	6K1696	BAR ASSEM.	2
11	1F748	NUT	2
12	6H1717	BOLT	12
13	6K1706	TUBE ASSEM.	1
14	6K1694	CLIP	1
15	6K1703	TUBE ASSEM.	1
16	6K1768	TUBE ASSEM.	1
17	2B947	BOLT	4
18	6J3650	SEAL	2
19	6K1794	TUBE ASSEM.	1
20	6K491	BRACKET (R.H.)	1
21	S1588	BOLT	8
22	1P4577	FLANGE	4
23	1P3703	SEAL	3
	S1595	BOLT	4

C INDICATES CHANGE

119203

LIFT CYLINDER LINES (6K1987 N/S)—Part 1

LIFT CYLINDER LINES (6K1987 N/S)—Part 2

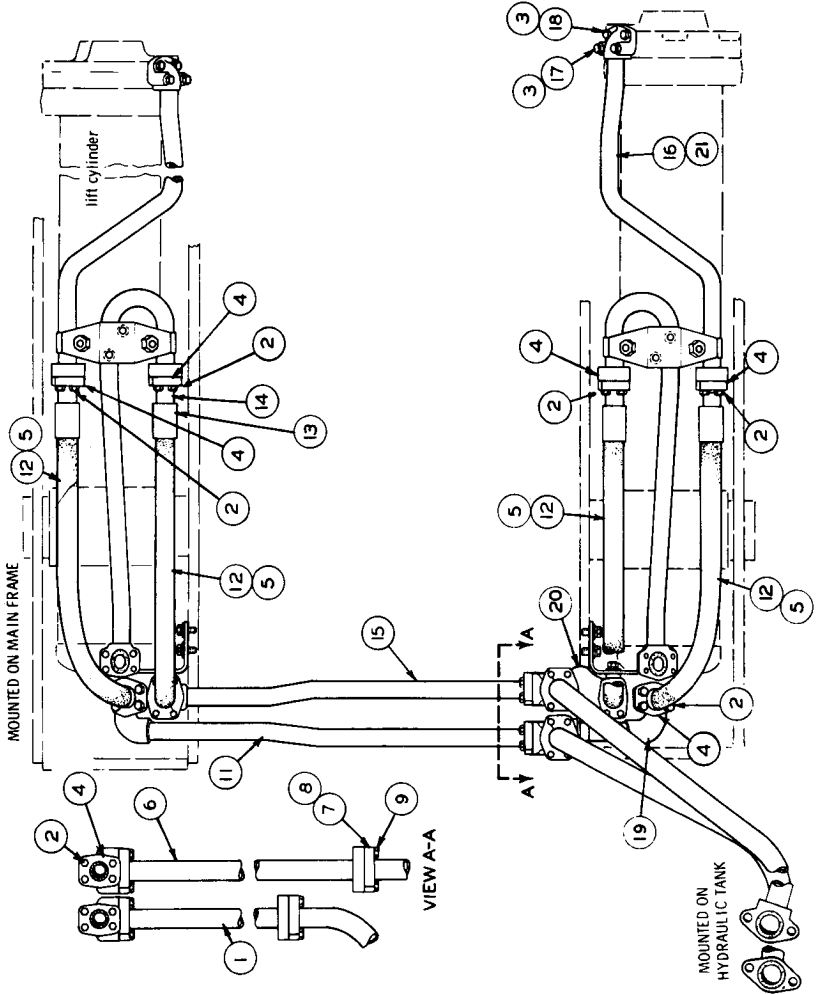

REF NO	PART NUMBER	DESCRIPTION	QTY
1	6K1788	TUBE ASSEM. -(22.85" long overall)-	1
2	S 1588	BOLT	32
3	3B4506	LOCKWASHER	4
4	1P4577	FLANGE	16
5	6J3600	SEAL	8
6	6K1790	TUBE ASSEM. -(28.41" long overall)-	1
7	1P4578	FLANGE	8
8	6J3625	SEAL	4
9	3H5368	BOLT	16
11	6K1159	TUBE ASSEM. -(31.68" long overall)-	1
12	5S9318	HOSE ASSEM.	4
13	8S9355	HOSE-----35.1 in.	2
14	3S7252	SIEVE	2
15	3S7251	STEM ASSEM.	2
16	6K1161	TUBE ASSEM. -(32.18" long overall)-	1
17	6K1705	TUBE ASSEM. -(31.42" long overall)-	1
18	6K1694	CLIP	1
19	S 1590	BOLT	2
20	1A2029	BOLT	2
21	6K1158	TUBE ASSEM. -(5.45" long overall)-	1
22	6K12	MANIFOLD	1
23	1P3703	SEAL	1

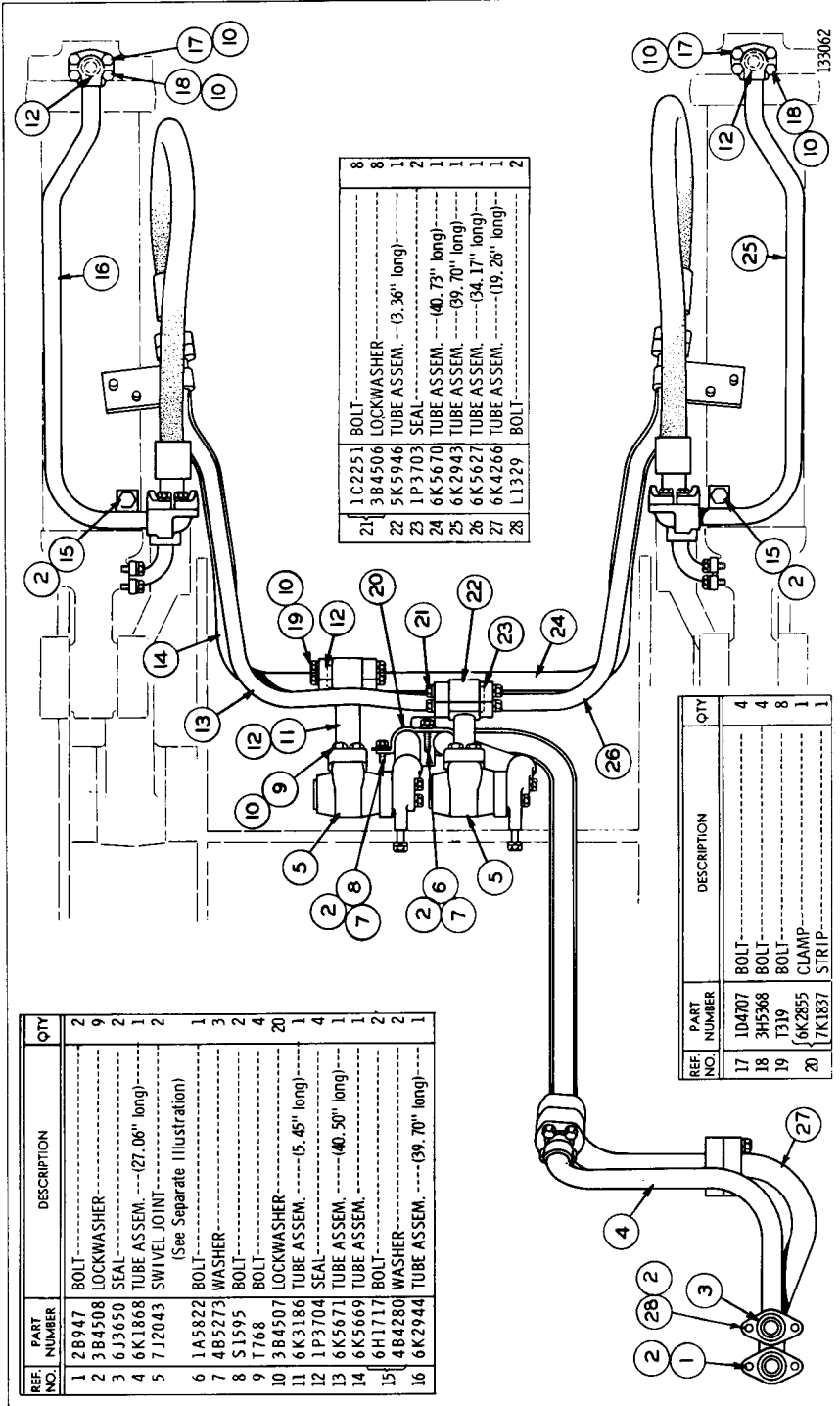

TILT CYLINDER LINES (6K2020 N/S)—Top View  
 Serial No. 11K5051 to 11K5353 inclusive  
 7J2043 Swivel Joint parts are shown on Page 141

133062



TILT CYLINDER LINES (6K2020 N/S)—As Viewed from Right Hand Side of Machine  
Serial No. 11K5051 to 11K5353 inclusive

REF. NO.	PART NUMBER	DESCRIPTION	QTY
1	1A1460	BOLT.....	16
2	3B4508	LOCKWASHER.....	24
3	6K1906	TUBE ASSEM. ....(32.15" long).....	1
4	6K1912	TUBE ASSEM. ....(25.51" long).....	4
5	6J3625	SEAL.....	4
6	6K2124	BOLT.....	4
7	1D4703	BOLT.....	4
8	3B4507	LOCKWASHER.....	28
9	T768	BOLT.....	6
10	1D4707	BOLT.....	2
11	5K5965	BRACKET ASSEM.....	2
12	6K3312	CLAMP.....	2
13	1H3305	FLANGE.....	8
14	6J3600	SEAL.....	4
15	S1588	BOLT.....	16
16	3B4506	LOCKWASHER.....	16
17	6K2938	HOSE ASSEM.....	2
18	3S7251	STEM ASSEM.....	1
19	3S7252	SLEEVE.....	2
20	8S9355	HOSE.....(46.60".....)	2
21	3S8495	STEM ASSEM.....	1
22	4K9887	SEAT.....	2

23	3H3667	FLANGE.....	8
24	T320	BOLT.....	16
25	7K516	HOSE ASSEM.....	2
26	8S9355	HOSE.....55".....	2
27	3S7252	SLEEVE.....	2
28	5S5969	STEM ASSEM.....	2
29	7B3235	BOLT.....	4
30	4B4273	WASHER.....	4

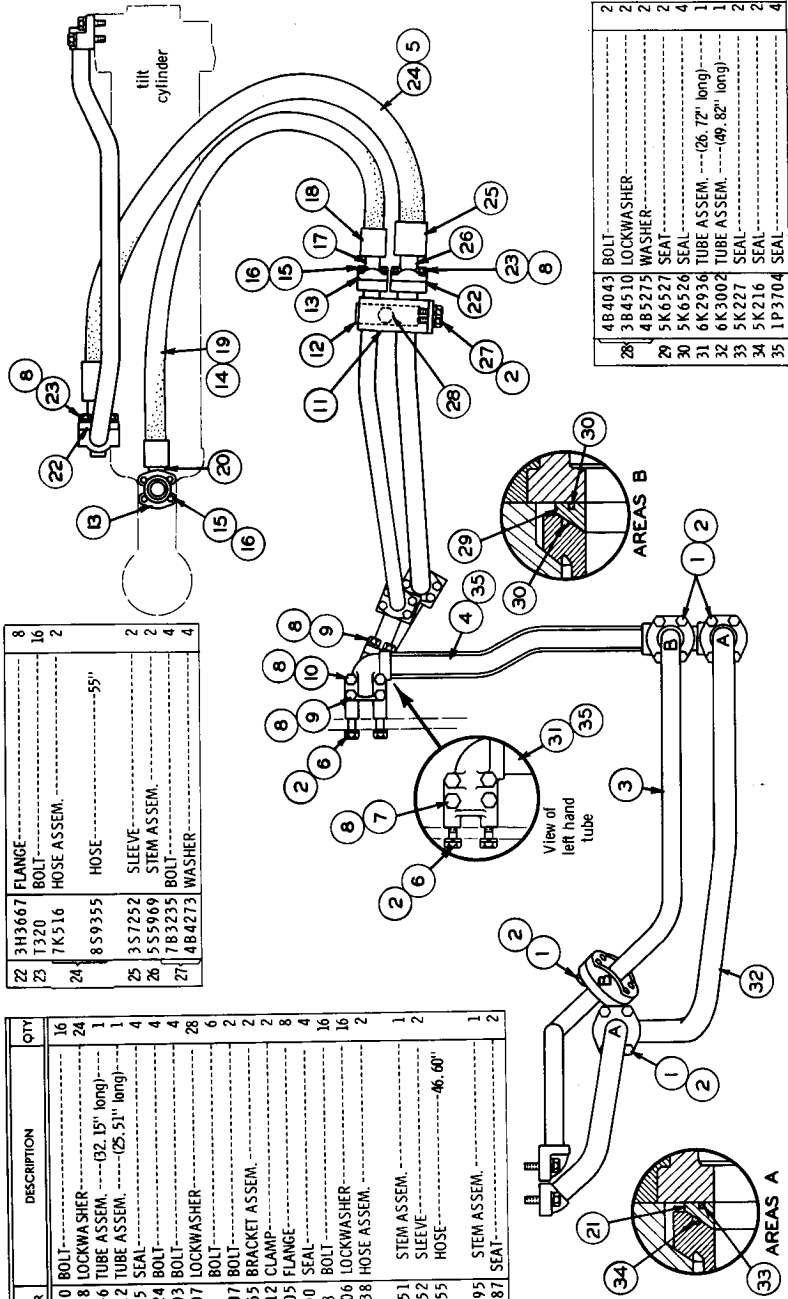

2	4B4043	BOLT.....	2
2	3B4510	LOCKWASHER.....	2
2	4B5275	WASHER.....	2
2	5K6527	SEAT.....	2
4	5K6526	SEAL.....	4
1	6K2936	TUBE ASSEM. ....(26.72" long).....	1
1	6K3002	TUBE ASSEM. ....(49.82" long).....	1
2	5K227	SEAL.....	2
2	5K216	SEAL.....	2
4	1P3704	SEAL.....	4

C INDICATES CHANGE  
138325

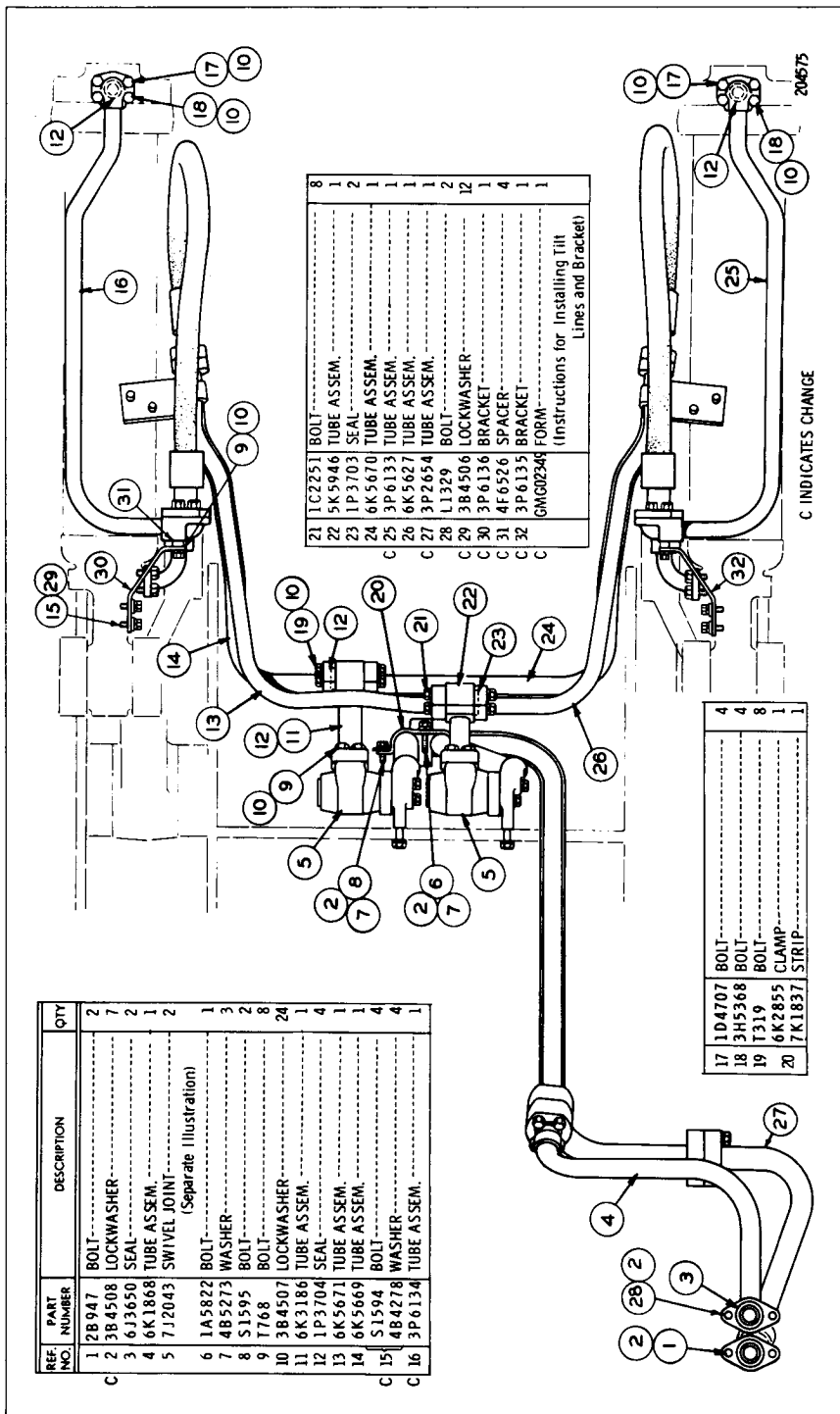

TILT CYLINDER LINES (6K2020 N/S)—Top View  
 Serial No. 11K5354—Up  
 7J2043 Swivel Joint parts are shown on Page 141

TILT CYLINDER LINES (6K2020 N/S)—As Viewed from Right Hand Side of Machine  
Serial No. 11K5354—Up

REF. NO.	PART NUMBER	DESCRIPTION	QTY
1	1A 1460	BOLT.....	16
2	3B4508	LOCKWASHER.....	24
3	6K1906	TUBE ASSEM.....	1
4	6K1912	TUBE ASSEM.....	1
5	6J3625	SEAL.....	4
6	S1587	BOLT.....	4
7	1D4703	BOLT.....	4
8	3B4507	LOCKWASHER.....	12
9	1768	BOLT.....	6
10	1D4707	BOLT.....	2
11	5K5965	BRACKET ASSEM.....	2
12	6K3312	CLAMP.....	2
13	1P4577	FLANGE.....	8
14	6J3600	SEAL.....	4
15	S1588	BOLT.....	16
17	6K2938	HOSE ASSEM.....	2
18	3S7251	STEM ASSEM.....	1
19	5P181	HOSE.....118.36 cm(46.60 in.)	2
20	3S8495	STEM ASSEM.....	1
21	4K9887	SEAT.....	2

22	1P4578	FLANGE.....	8
23	T320	BOLT.....	16
24	7K516	HOSE ASSEM.....	2
25	5P181	HOSE.....1.91.70 cm(55 in.)	2
26	3S7252	SLEEVE.....	2
27	5S5969	STEM ASSEM.....	2
28	783235	BOLT.....	4
29	4B4273	WASHER.....	4

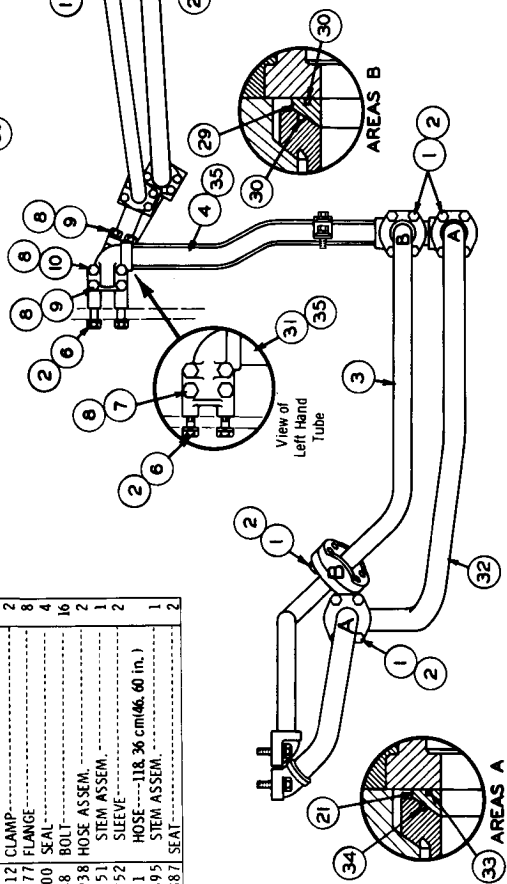
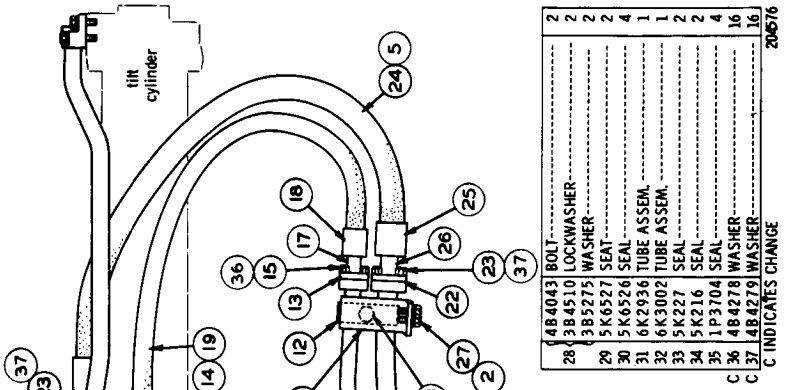

4B4043	BOLT.....	2
3B84510	LOCKWASHER.....	2
3B85275	WASHER.....	2
5K6527	SEAT.....	2
5K6526	SEAL.....	4
6K2936	TUBE ASSEM.....	1
6K3002	TUBE ASSEM.....	1
5K227	SEAL.....	2
5K216	SEAL.....	2
1P3704	SEAL.....	4
4B4278	WASHER.....	16
4B4279	WASHER.....	16

A ORDER BY THE CENTIMETRE  
C INDICATES CHANGE  
20676

5K6273 4 VALVE--FOR USE WITH FRONT ATTACHMENTS WITH  
AUXILIARY CYLINDER RELIEF

CONSISTS OF:

PAGE

1	5J5726	TANK AND VALVE GROUP.....	168
	- OR -		
1	9J646	TANK AND VALVE GROUP.....	172F
1	5K6270	HYDRAULIC LINES GROUP.....	184
1	5K6271	HAND CONTROL GROUP.....	122
1	.....	INSTRUCTION FORM No. FE055046	

2P8032 4 VALVE--FOR USE WITH FRONT AND REAR ATTACHMENTS  
WITH AUXILIARY CYLINDER RELIEF

CONSISTS OF:

1	5J5726	TANK AND VALVE GROUP.....	168
	- OR -		
1	9J646	TANK AND VALVE GROUP.....	172F
1	5K6270	HYDRAULIC LINES GROUP.....	184
1	6K2500	HAND CONTROL GROUP.....	121
1	2P7607	HYDRAULIC LINES GROUP.....	186
1	.....	INSTRUCTION FORM No. FM055046	

CONSISTS OF:		PAGE
1	5J5724 TANK AND VALVE GROUP.....	151
	- OR -	
1	9J644 TANK AND VALVE GROUP.....	155F
1	5K6270 HYDRAULIC LINES GROUP.....	184
1	6K2500 HAND CONTROL GROUP.....	121
1	2P7607 HYDRAULIC LINES GROUP.....	186
1	..... INSTRUCTION FORM No. FM055046	

9K4118 HYDRAULIC ARRANGEMENT—Factory Installation  
 4 VALVE—FOR USE WITH FRONT AND REAR ATTACHMENTS AND  
 ROLL-OVER PROTECTIVE STRUCTURE MOUNTING. AN ATTACHMENT

CONSISTS OF:		PAGE
1	5J5724 TANK AND VALVE GROUP.....	151
	- OR -	
1	9J644 TANK AND VALVE GROUP.....	155F
1	5K6270 HYDRAULIC LINES GROUP.....	184
1	5K6271 HAND CONTROL GROUP.....	122
1	..... INSTRUCTIONS FORM No. FE055046	

5K6269 HYDRAULIC ARRANGEMENT—Factory Installation  
 4 VALVE—FOR USE WITH FRONT ATTACHMENTS  
 AN ATTACHMENT

## CATERPILLAR 977L TRAXCAVATOR

CONSISTS OF:		PAGE
1	5J5724 TANK AND VALVE GROUP.....	151
	- OR -	
1	9J644 TANK AND VALVE GROUP.....	155F
1	5K6270 HYDRAULIC LINES GROUP.....	184
1	5K6280 HYDRAULIC LINES GROUP.....	186
1	6K2500 HAND CONTROL GROUP.....	121
1	..... INSTALLATION INSTRUCTIONS FORM No. FE055046	

**5K6278 HYDRAULIC ARRANGEMENT—Factory Installation  
4 VALVE—FOR USE WITH FRONT AND REAR ATTACHMENTS  
AN ATTACHMENT**

CONSISTS OF:		PAGE
1	5J5724 TANK AND VALVE GROUP.....	151
	- OR -	
1	9J644 TANK AND VALVE GROUP.....	155F
1	5K6276 HAND CONTROL GROUP.....	120
1	2P7607 HYDRAULIC LINES GROUP.....	186
1	..... INSTRUCTION FORM No. FM055046	

**2P8033 HYDRAULIC ARRANGEMENT—Factory Installation  
4 VALVE—FOR USE WITH REAR ATTACHMENTS  
AN ATTACHMENT**

CONSISTS OF:		PAGE
1	5J5723 CONVERSION GROUP.....	192
1	5K6276 HAND CONTROL GROUP.....	120
1	5K6280 HYDRAULIC LINES GROUP.....	186
1	..... INSTRUCTION FORM No. FE055046	

5K9839 FIELD CONVERSION ARRANGEMENT  
Serial No. 11K5051 to 11K6202 inclusive. FOR USE WITH REAR MOUNTED  
ATTACHMENTS. TO CONVERT A 2 VALVE TO 4 VALVE  
AN ATTACHMENT

3P7543 FOR USE WITH FRONT MOUNTED ATTACHMENTS  
TO CONVERT A 2 VALVE TO 4 VALVE

CONSISTS OF:

PAGE

1	9J635	CONVERSION GROUP.....	192A
1	5K6270	HYDRAULIC LINES GROUP.....	184
1	5K6271	HAND CONTROL GROUP.....	122
1	.....	INSTRUCTION FORM No. FE055046	

3P7544 FOR USE WITH REAR MOUNTED ATTACHMENTS  
TO CONVERT A 2 VALVE TO 4 VALVE

CONSISTS OF:

1	9J635	CONVERSION GROUP.....	192A
1	5K6276	HAND CONTROL GROUP.....	120
1	2P7607	HYDRAULIC LINES GROUP.....	186
1	.....	INSTRUCTION FORM No. FM055046	

3P7547 FOR USE WITH FRONT AND REAR MOUNTED ATTACHMENTS  
TO CONVERT A 2 VALVE TO 4 VALVE

CONSISTS OF:

1	9J635	CONVERSION GROUP.....	192A
1	5K6270	HYDRAULIC LINES GROUP.....	184
1	6K2500	HAND CONTROL GROUP.....	121
1	2P7607	HYDRAULIC LINES GROUP.....	186
1	.....	INSTRUCTION FORM No. FE055046	



## 6P2276 FOR USE WITH FRONT MOUNTED ATTACHMENTS

## CONSISTS OF:

PAGE

1	9J637	FIELD CONVERSION GROUP.....	192D
1	5K6270	FRONT LINES GROUP.....	184
1	5K6271	HAND CONTROL GROUP.....	122
1	.....	INSTRUCTION FORM 55046	

## 6P2278 FOR USE WITH FRONT AND REAR MOUNTED ATTACHMENTS

## CONSISTS OF:

1	9J637	FIELD CONVERSION GROUP.....	192D
1	5K6270	FRONT LINES GROUP.....	184
1	6K2500	HAND CONTROL GROUP.....	121
1	2P7607	REAR LINES GROUP.....	186
1	.....	INSTRUCTION FORM 55046	

## FIELD CONVERSION ARRANGEMENTS

Serial No. 11K6203—Up. TO CONVERT FROM 2 TO 4 VALVE WITH  
AUXILIARY CYLINDER RELIEF. Only separate parts serviced

# CATERPILLAR 977L TRAXCAVATOR

## 6P2279 FOR USE WITH FRONT MOUNTED ATTACHMENTS

### CONSISTS OF:

PAGE

1	5J5725	FIELD CONVERSION GROUP.....	192C
1	5K6270	FRONT LINES GROUP.....	184
1	5K6271	HAND CONTROL GROUP.....	122
1	.....	INSTRUCTION FORM FE55046	

## 6P2277 FOR USE WITH FRONT AND REAR MOUNTED ATTACHMENTS

### CONSISTS OF:

1	5J5725	FIELD CONVERSION GROUP.....	192C
1	5K6270	FRONT LINES GROUP.....	184
1	5K6280	REAR LINES GROUP.....	186
1	6K2500	HAND CONTROL GROUP.....	121
1	.....	INSTRUCTION FORM FE55046	

### FIELD CONVERSION ARRANGEMENTS

Serial No. 11K5051 to 11K6202 inclusive. TO CONVERT FROM 2 TO 4 VALVE WITH AUXILIARY CYLINDER RELIEF

Only separate parts serviced

5K9838 FOR USE WITH FRONT MOUNTED ATTACHMENTS  
TO CONVERT A 2 VALVE TO 4 VALVE

CONSISTS OF:

PAGE

1	5J5723	CONVERSION GROUP.....	192
1	5K6270	HYDRAULIC LINES GROUP.....	184
1	5K6271	HAND CONTROL GROUP.....	122
1	.....	INSTRUCTION FORM No. FE055046	

5K9873 FOR USE WITH FRONT AND REAR MOUNTED ATTACHMENT  
TO CONVERT A 2 VALVE TO 4 VALVE

CONSISTS OF:

1	5J5723	CONVERSION GROUP.....	192
1	5K6270	HYDRAULIC LINES GROUP.....	184
1	5K6280	HYDRAULIC LINES GROUP.....	186
1	6K2500	HAND CONTROL GROUP.....	121
1	.....	INSTRUCTION FORM No. FE055046	

9K4343 FOR USE WITH FRONT AND REAR MOUNTED ATTACHMENTS  
AND ROLL-OVER PROTECTIVE STRUCTURE MOUNTING  
TO CONVERT A 2 VALVE TO 4 VALVE

CONSISTS OF:

1	5J5723	CONVERSION GROUP.....	192
1	5K6270	HYDRAULIC LINES GROUP.....	184
1	6K2500	HAND CONTROL GROUP.....	121
1	2P7607	HYDRAULIC LINES GROUP.....	186
1	.....	INSTRUCTION FORM No. FE055046	

2P8034 FOR USE WITH REAR MOUNTED ATTACHMENTS AND ROLL-  
OVER PROTECTIVE STRUCTURE MOUNTING  
TO CONVERT A 2 VALVE TO 4 VALVE

CONSISTS OF:

1	5J5723	CONVERSION GROUP.....	192
1	5K6276	HAND CONTROL GROUP.....	120
1	2P7607	HYDRAULIC LINES GROUP.....	186
1	.....	INSTRUCTION FORM No. FM055046	

CONSISTS OF:		PAGE
1	6J7041 TANK AND VALVE GROUP.....	164
	- OR -	
1	9J641 TANK AND VALVE GROUP.....	167E
1	7J9657 CYLINDER GROUP--R.H. ....	131
	- OR -	
1	9J671 CYLINDER GROUP--R.H. ....	132
1	7J9658 CYLINDER GROUP--L.H. ....	133
	- OR -	
1	9J670 CYLINDER GROUP--L.H. ....	134
1	7J9659 CYLINDER GROUP--R.H. ....	124
1	7J9660 CYLINDER GROUP--L.H. ....	126
1	6K7376 WARNING AND WIRING GROUP.....	45
1	9K1094 VANE PUMP GROUP.....	183
	- OR -	
1	3P5681 GEAR PUMP GROUP.....	182
1	..... PAINT AND LUBRICANT LIST.....	254A

6K5440 HYDRAULIC ARRANGEMENT—Fire Resistant Fluid—Factory Installation  
 For Machines operating in areas where fires are a possibility. Also part of  
 8S9777, 1P9414 and 3P1470 Traxcavator Arrangements listed on Pages  
 103 and 103B. AN ATTACHMENT

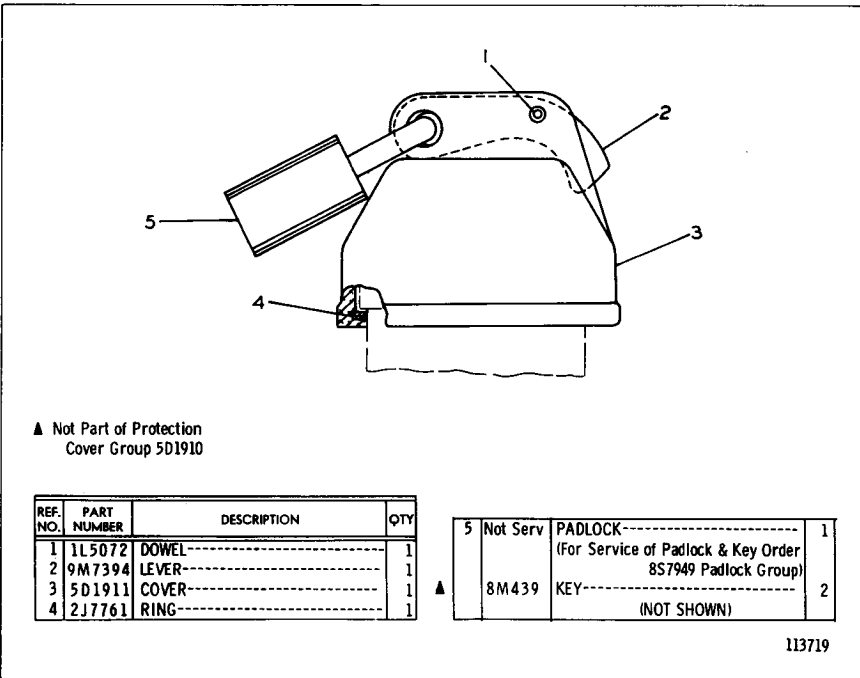

▲ Not Part of Protection  
 Cover Group 5D1910

REF. NO.	PART NUMBER	DESCRIPTION	QTY
1	1L5072	DOWEL-----	1
2	9M7394	LEVER-----	1
3	5D1911	COVER-----	1
4	2J7761	RING-----	1

5	Not Serv	PADLOCK-----	1
		(For Service of Padlock & Key Order 8S7949 Padlock Group)	
▲	8M439	KEY-----	2
		(NOT SHOWN)	

113719

5D1910 PROTECTION COVER GROUP—Hydraulic Tank Cap  
 Also part of 6J7041 Hydraulic Tank and Valve Gropp and 2P5300 and 3P7735  
 Vandalism Protection Arrangements shown on Pages 166 and 227  
 AN ATTACHMENT

5J5724 HYDRAULIC TANK AND VALVE GROUP—Part 1 of 5—Type 1  
 Part of 9K4118, 5K6269, 5K6278 and 2P8033 Hydraulic Arrangements listed on Pages 148A and 148B  
 5J7953 Control Valve parts are shown on Pages 174 through 175B  
 AN ATTACHMENT

REF. NO.	PART NUMBER	DESCRIPTION	QTY.
1	165	BOLT	2
2	384506	LOCKWASHER	7
3	5J5931	TUBE ASSEM.	1

4	6J2363	TUBE	1
5	5J5146	BRACKET	1
6	6H1717	BOLT	2
7	384508	LOCKWASHER	10
8	484280	WASHER	1
9	6J2362	TUBE	1
10	5J585	BOLT	2
11	388995	FITTING	2
12	1F1344	NUT	1

13	1318	BOLT	2
	384507	LOCKWASHER	2
	484279	WASHER	2
14	7F8267	SEAL	1
15	381915	BOLT	1
		(1.375" Long)	1
16	309412	GASKET	1
17	7J3572	TUBE ASSEM.	1
18	5J9261	DISC	1
	5J5942	GASKET	1
19	5J6022	TUBE ASSEM.	1
20	388996	FITTING	2
21	8F8997	NUT	1
22	389053	FITTING	1
23	8F8998	NUT	1
24	7J748	TUBE	1
25	5J5942	GASKET	1
26	5J5108	LEVER	1
27	5J7953	CONTROL VALVE GROUP	1
		(Separate Illustration)	
	5F9199	PIN	1
	8S7803	RETAINER	1
28	8F3469	SEAL	4
29	783235	BOLT	4
30	783235	BOLT	4
31	7J6226	BRACKET	1
32	6H962	SPRING	1
33	5J5932	ROD	1
34	1J8489	END	1
	589079	NUT	1
35	5J5110	LEVER	1
	188706	KEY	1
36	1A2209	BOLT	1
37	8J135	PLUG	1
38	5J619	BOLT	2
39	5J595	BOLT	2
40	8J2288	SPACER	1
	8H9819	ADAPTER	1
41	8H9818	GASKET	1
42	1L143	BOLT	2
43	2459330	BOLT	2
		(2.875" Long)	1
44	487759	PLUG	1
45	485167	WASHER	2

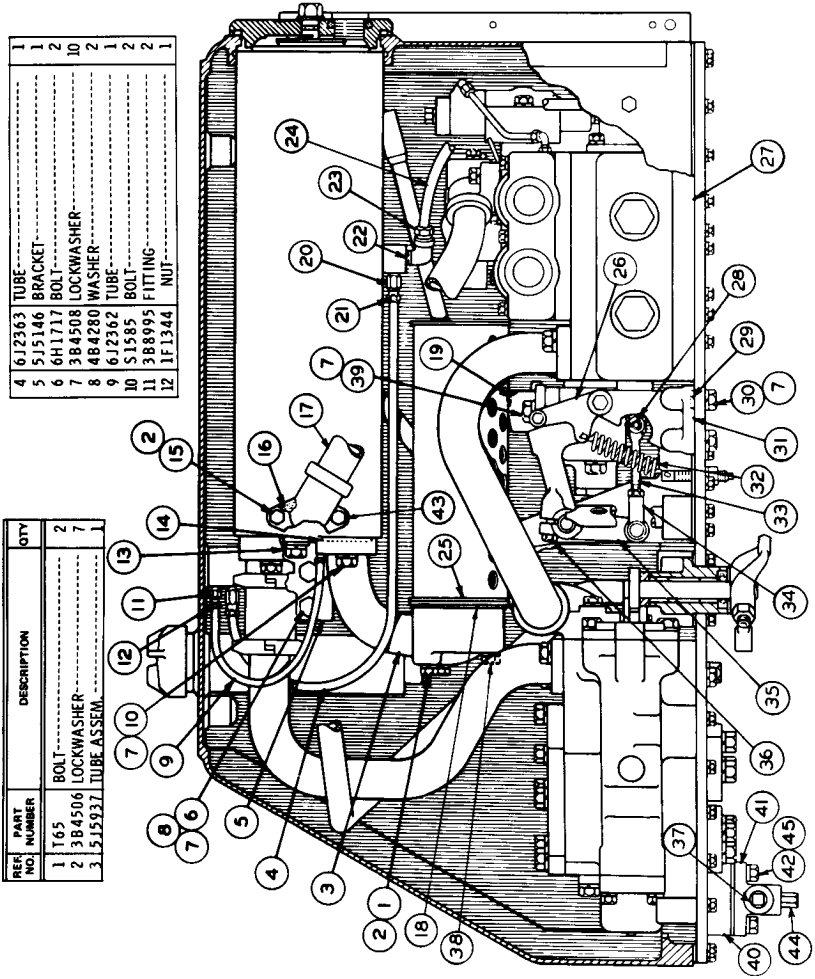

119218

REF. NO.	PART NUMBER	DESCRIPTION	QTY
1	5J5179	TUBE ASSEM.	1
2	6L2849	COUPLING	1
3	18J2352	GASKET	2

4	5J587	BOLT	2
5	3B4508	LOCKWASHER	2
6	5J5157	TUBE ASSEM.	1

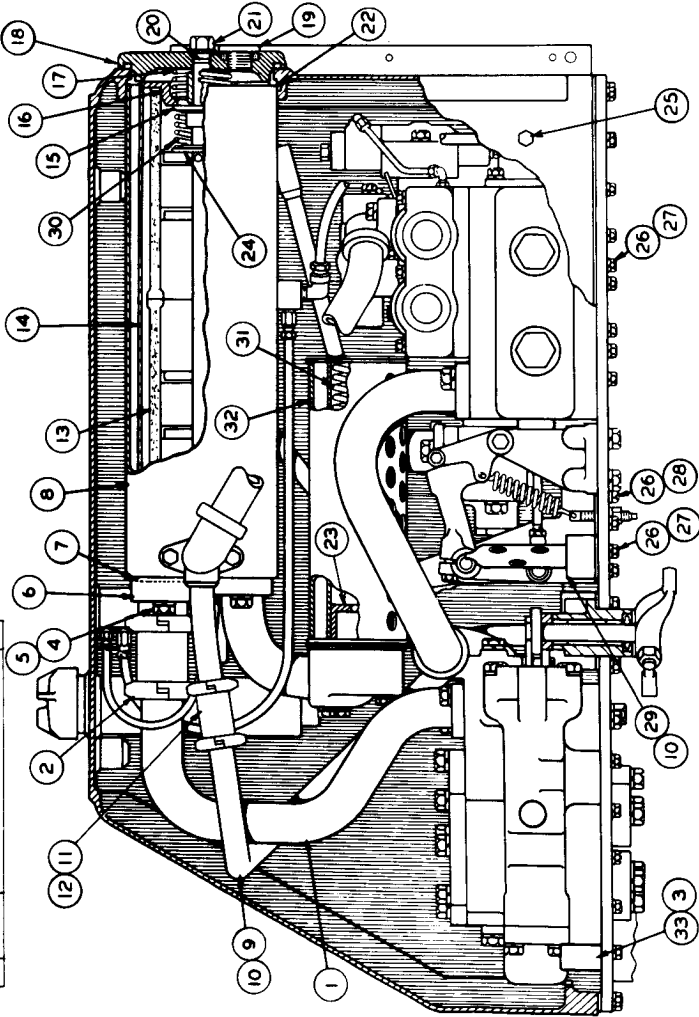

7	5F8000	SEAL	1
8	7J6096	TUBE ASSEM.	1
9	5J5702	TUBE ASSEM.	1
10	5J5166	GASKET	2
11	257070	JOINT ASSEM.	1
12	9S2082	SEAL ASSEM.	2
13	4J6064	ELEMENT ASSEM.	2
14	6J3795	SCREEN ASSEM.	1
15	2J918	VALVE	1
16	4J1704	SEAT	1
17	6J2236	SPRING	1
18	7J9197	COVER	1
19	5L5032	SEAL	1
20	9S8010	PLUG	2
21	254078	SEAL	2
22	6F4855	SEAL	1
23	7J3586	BOLT	1
24	2K4472	SEAL	1
25	6J3908	ORIFICE	1
26	2J917	RETAINER	1
27	1H1200	PIN—(1.25" Long)	1
28	7J5925	PIN—(1.125" Long)	1
29	9S4182	PLUG	1
30	3J7354	SEAL	1
31	1A2029	BOLT	11
32	3B4506	LOCKWASHER	8
33	4B5167	WASHER	3
34	7J772	TUBE ASSEM.	1
35	5J2926	SPRING	1
36	6J3911	SPRING	1
37	7J773	TUBE ASSEM.	1
38	8J2381	BLOCK	2
39	3F4479	PIN	2

5J5724 HYDRAULIC TANK AND VALVE GROUP—Part 2 of 5—Type 1  
 Part of 9K4118, 5K6269, 5K6278 and 2P8033 Hydraulic Arrangements listed on Pages 148A and 148B  
 AN ATTACHMENT

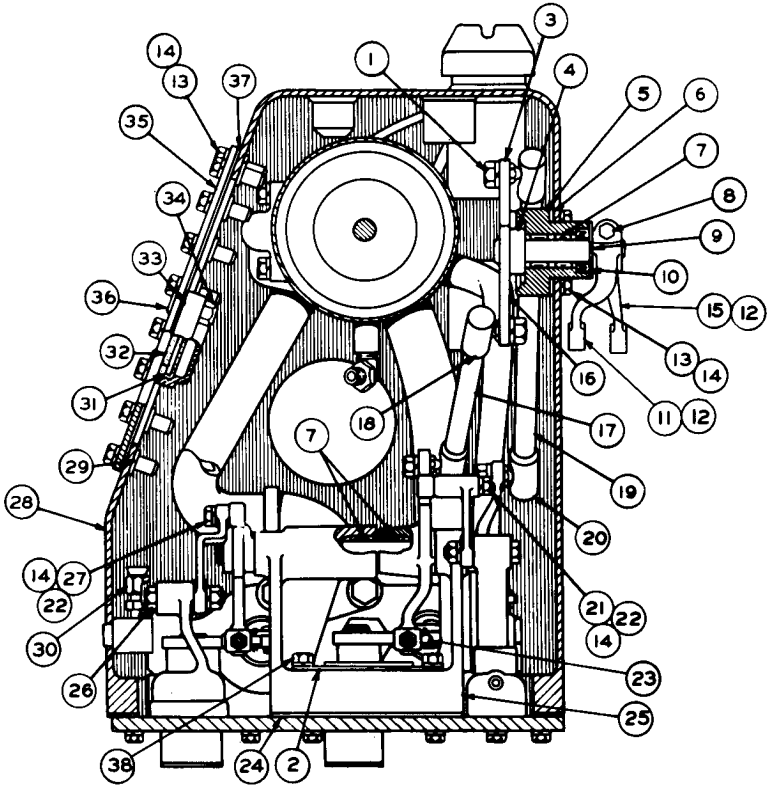

REF. NO.	PART NUMBER	DESCRIPTION	QTY
1	1B4205	NUT-----	4
	3B4508	LOCKWASHER-----	4
2	6J8118	SCREEN ASSEM.-----	1
3	5J5774	LEVER ASSEM.-----	1
4	2H5746	ADAPTER-----	2
5	5J8102	HOUSING-----	2
6	4J8425	GASKET-----	2
7	7F7983	BEARING-----	8
8	S1571	BOLT-----	2
	1D4717	NUT-----	2
9	8B4037	WASHER-----	2
10	3J4407	SEAL-----	2
11	7J7557	LEVER-----	1
12	1B8706	KEY-----	2
13	S1594	BOLT-----	52
14	3B4506	LOCKWASHER-----	56
15	5J5729	LEVER-----	1
16	5J5776	LEVER ASSEM.-----	1
17	5J5765	ROD ASSEM.-----	1
18	2H9250	JOINT-----	2
19	5J5764	ROD ASSEM.-----	1
20	2H9250	JOINT-----	2

21	4J3441	ROLLER-----	1
22	1B4203	NUT-----	2
	5F9199	PIN-----	2
23	8S7803	RETAINER-----	2
24	5J5247	GASKET-----	1
25	7J779	BRACKET-----	1
	2J6602	PIN-----	2
26	1B4204	NUT-----	2
	3B4507	LOCKWASHER-----	2
27	2J8262	ROLLER-----	1
28	7J775	TANK ASSEM.-----	1
29	6J2237	BOSS-----	44
	3B8997	FITTING-----	1
30	8F8998	NUT-----	1
31	4J8292	GLASS-----	1
32	4J8251	GROMMET-----	1
33	4J8250	RETAINER-----	1
34	4J8265	NUT-----	4
35	6J2459	COVER ASSEM.-----	1
	5J5159	COVER-----	1
36	5J96	STUD-----	4
37	5J5160	GASKET-----	1
	2H3755	BOLT-----	2
38	3B4505	LOCKWASHER-----	2

119220

5J5724 HYDRAULIC TANK AND VALVE GROUP—Part 3 of 5—Type 1  
 Part of 9K4118, 5K6269, 5K6278 and 2P8033 Hydraulic Arrangements  
 listed on Pages 148A and 148B. AN ATTACHMENT

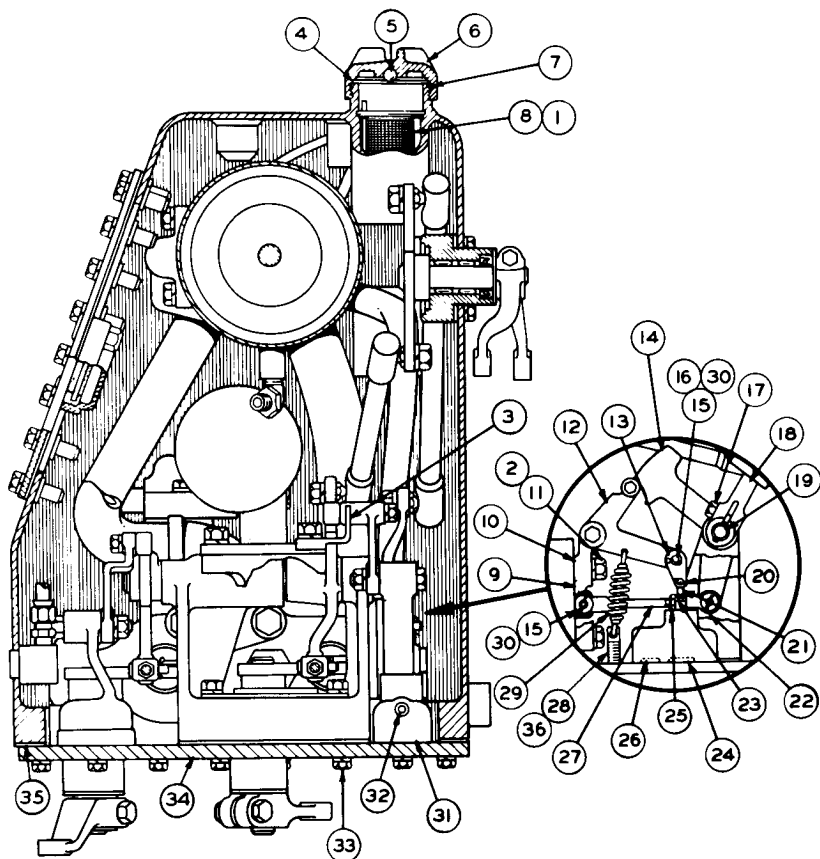

REF. NO.	PART NUMBER	DESCRIPTION	QTY
1	4J524	SEAL-----	1
C	2	3B4508 LOCKWASHER-----	2
3	6J4578	STOP-----	1
4	6H5139	PLATE-----	1
5	7B6368	BALL-----	1
6	7H1447	CAP-----	1
7	9H6454	GASKET-----	1
C	8	8J5890 STRAINER-----	1
9	4J519	SEAL-----	1
10	5J5109	BRACKET-----	1
11	51585	BOLT-----	2
12	5J5071	LEVER-----	1
13	5J7518	LINK-----	2
14	5J5111	LEVER-----	1
15	5F9199	PIN-----	2
16	7H3912	BUSHING-----	1
17	51588	BOLT-----	1
18	4J7739	LEVER-----	1
18	1B8706	KEY-----	1
19	5J5105	SHAFT-----	1

20	2S975	PIN-----	1
	3B4607	COTTER PIN-----	1
21	5J7546	ROD-----	1
22	1J8489	END-----	1
23	6F612	NUT-----	1
24	5F7054	SEAL-----	1
25	5B9079	NUT-----	1
26	6F4855	SEAL-----	1
27	5J5933	ROD-----	1
	7J6227	EYE SCREW-----	2
C	28	1D4717 NUT-----	2
C		5M2894 WASHER-----	2
29	6H962	SPRING-----	1
30	8S7803	RETAINER-----	2
31	5J7958	BODY GROUP-----	1
32	3D4603	PLUG-----	1
33	T320	BOLT-----	52
33	3B4507	LOCKWASHER-----	52
34	8J2333	PLATE-----	1
35	5J5234	GASKET-----	1
C	36	8J6775 SEAL-----	2

C INDICATES CHANGE

119221

5J5724 HYDRAULIC TANK AND VALVE GROUP—Part 4 of 5—Type 1  
Part of 9K4118, 5K6269, 5K6278 and 2P8033 Hydraulic Arrangements  
listed on Pages 148A and 148B. AN ATTACHMENT



5J724 HYDRAULIC TANK AND VALVE GROUP—Part 5 of 5—Type 1  
 Part of 9K4118, 5K6269, 5K6278 and 2P8033 Hydraulic Arrangements listed on Pages 148A and 148B  
 5J7955 Valve parts are shown on Page 173. AN ATTACHMENT

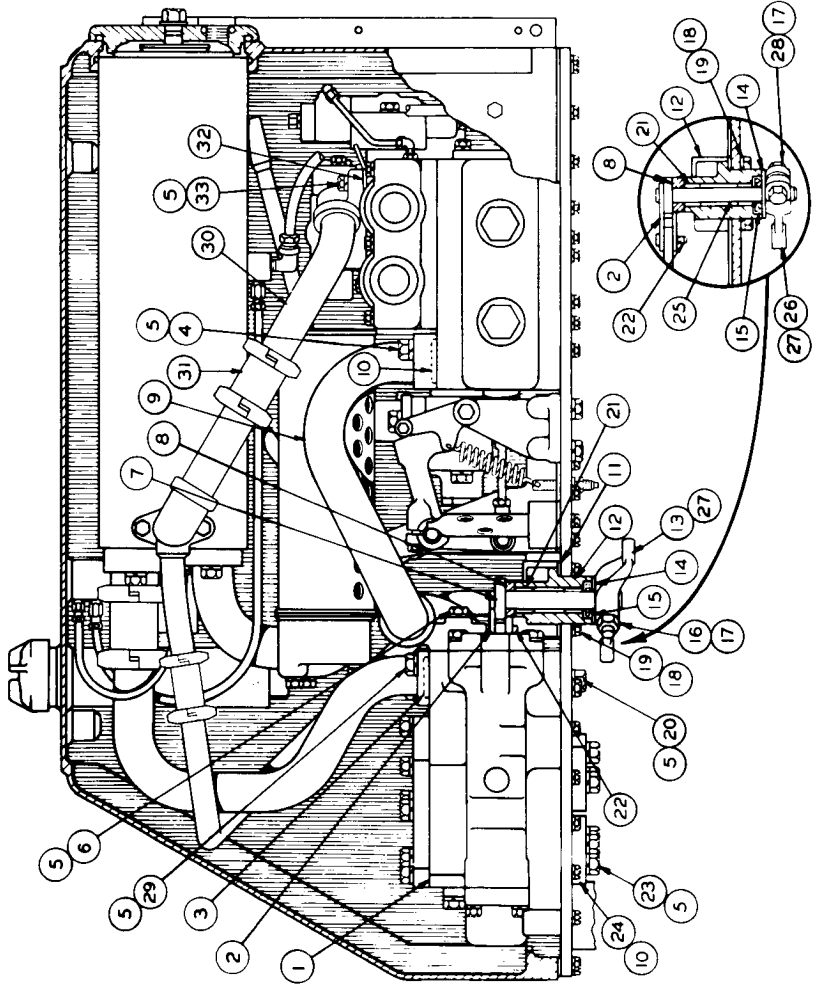

REF. NO.	PART NUMBER	DESCRIPTION	QTY
1	5J7955	VALVE GROUP.....	1
2	4J7942	LINK.....	4
3	1H9696	SEAL.....	1
4	51587	BOLT.....	2
5	3B4508	LOCKWASHER.....	16
6	9S1366	BOLT.....	2
7	5J916	LEVER ASSEM.....	1
8	2H5746	ADAPTER.....	2
9	5J5151	TUBE ASSEM.....	1
10	4J522	SEAL.....	1
11	4J8425	GASKET.....	5
12	8J7240	HOUSING.....	2
13	6J2449	LEVER.....	1
14	8B4037	WASHER.....	2
15	3J4407	SEAL.....	2
16	51571	BOLT.....	1
17	1D4717	NUT.....	2
18	3B4506	LOCKWASHER.....	10
19	51588	BOLT.....	8
20	7B3235	BOLT.....	2
21	7F7983	BEARING.....	4
22	5F9199	PIN.....	4
23	857803	RETAINER.....	4
24	7H3912	BUSHING.....	4
25	1A1460	BOLT.....	2
26	3K2759	COVER.....	8
27	5J6823	LEVER ASSEM.....	4
28	3J552	LEVER.....	1
29	1B8706	KEY.....	1
30	51590	BOLT.....	2
31	51585	BOLT.....	2
32	7J3570	TUBE ASSEM.....	1
33	7S8062	JOINT.....	1
34	7J3573	GASKET.....	1
35	2B2006	BOLT.....	2

C INDICATES CHANGE

118222

REF. NO.	PART NUMBER	DESCRIPTION	QTY.
1	T65	BOLT	2
2	384506	LOCKWASHER	7
3	515937	TUBE ASSEM.	1
4	612363	TUBE	1
5	515146	BRACKET	2
6	6H11717	BOLT	10
7	384508	LOCKWASHER	10
8	484280	WASHER	2
9	612362	TUBE	1
10	S1585	BOLT	2
11	388995	FITTING	2
12	1F1344	NUT	1

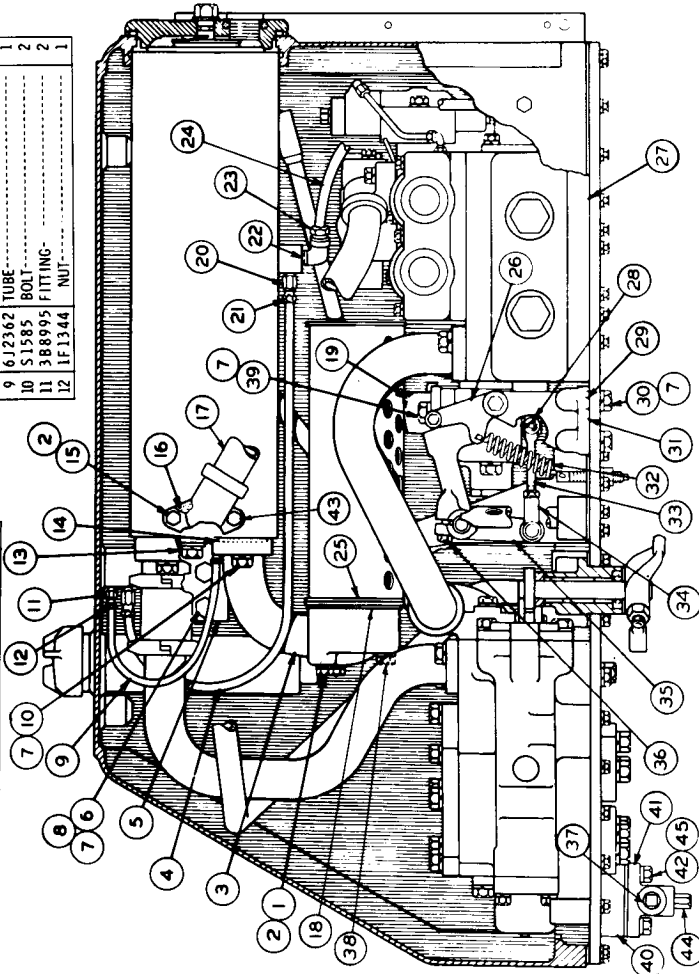

13	1318	BOLT	2
	384507	LOCKWASHER	2
	484279	WASHER	2
14	7F8267	SEAL	1
15	381915	BOLT	1
		(-1.375" Long)	
16	309412	GASKET	1
17	713572	TUBE ASSEM.	1
18	519261	DISC	1
	515942	GASKET	1
19	516022	TUBE ASSEM.	1
20	388996	FITTING	2
21	8F8997	NUT	1
22	389053	FITTING	1
23	8F8998	NUT	1
24	71748	TUBE	1
25	515942	GASKET	1
26	515108	LEVER	1
27	517953	CONTROL VALVE GROUP	1
		(Separate Illustration)	
28	5F9199	PIN	1
	857803	RETAINER	1
29	8F3469	SEAL	4
30	783235	BOLT	4
31	716226	BRACKET	1
32	64962	SPRING	1
33	515932	ROD	1
34	118489	END NUT	1
	589079	NUT	1
35	515110	LEVER	1
	188706	KEY	1
36	1A2209	BOLT	1
37	81135	PLUG	2
38	S1619	BOLT	1
39	S1595	BOLT	2
40	812288	SPACER	1
41	8H9819	ADAPTER	1
	8H9818	GASKET	2
42	L1143	BOLT	2
43	2H5330	BOLT	1
		(-2.875" Long)	
44	487739	PLUG	1
45	485167	WASHER	2

119218

5J5724 HYDRAULIC TANK AND VALVE GROUP—Part 1 of 5—Type 2  
 Part of 5K6269, 9K4118, 5K6278 and 2P8033 Hydraulic Arrangements listed on Pages 148A and 148B, 5J7953 Control Valve parts are shown on Pages 174 and 175. Only separate parts serviced. When complete Group is required, order 9J644 shown on Pages 155F through 155K. AN ATTACHMENT

5J5724 HYDRAULIC TANK AND VALVE GROUP—Part 2 of 5—Type 2  
 Part of 5K6259, 9K4118, 5K6278 and 2P8033 Hydraulic Arrangements listed on Pages 148A and 148B  
 Only separate parts serviced. When complete Group is required, order 9J644 shown on Pages 155F through 155K  
 AN ATTACHMENT

REF. NO.	PART NUMBER	DESCRIPTION	QTY.
1	515179	TUBE ASSEM.	1
2	6L2849	COUPLING	1
3	8J2352	GASKET	2

4	51587	BOLT	2
5	384508	LOCKWASHER	2
6	515157	TUBE ASSEM.	1

7	5F8000	SEAL	1
8	7J6096	TUBE ASSEM.	1
9	5J5202	TUBE ASSEM.	2
10	5J5166	GASKET	1
11	2S7070	JOINT ASSEM.	2
12	9S2082	SEAL ASSEM.	1
13	4J6064	ELEMENT ASSEM.	2
14	6J3795	SCREEN ASSEM.	1
15	2J918	VALVE	1
16	4J1704	SEAT	1
17	6J2236	SPRING	1
18	7J9197	COVER	1
19	5L5032	SEAL	1
20	9S8010	PLUG	2
21	2S4078	SEAL	2
22	6F4855	SEAL	1
23	7J5586	BOLT	1
24	2K4472	SEAL	1
25	6J3908	ORIFICE	1
26	2J917	RETAINER	1
27	1H1200	PIN	1
28	7J5925	PIN	1
29	9S4182	PLUG	1
30	3J7354	SEAL	1
31	1A2029	BOLT	11
32	384508	LOCKWASHER	8
33	485167	WASHER	3
34	7J772	TUBE ASSEM.	1
35	5J2926	SPRING	1
36	6J3911	SPRING	1
37	7J773	TUBE ASSEM.	1
38	8J2381	BLOCK	2
39	3F4479	PIN	2

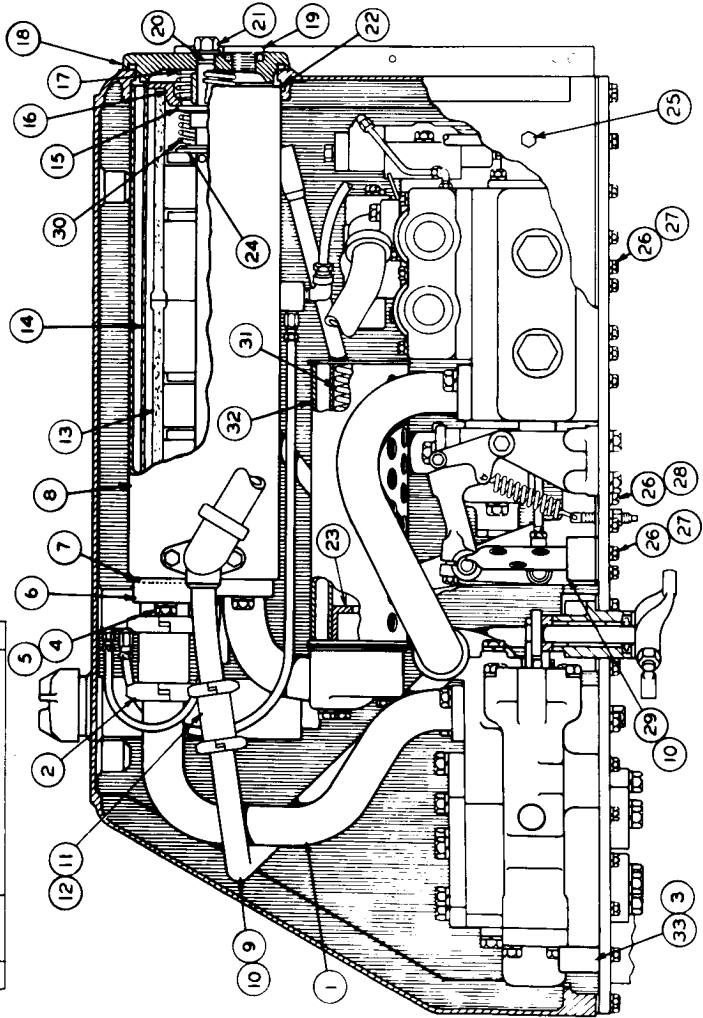

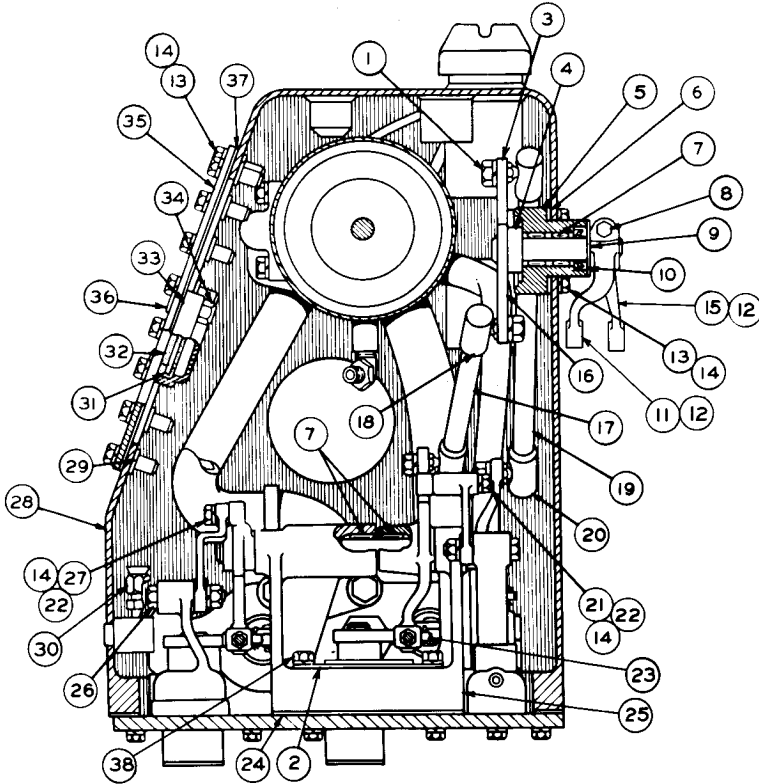

REF. NO.	PART NUMBER	DESCRIPTION	QTY
1	1B4205	NUT	4
	3B4508	LOCKWASHER	4
	6J8118	SCREEN ASSEM.	1
3	5J5774	LEVER ASSEM.	1
4	2H5746	ADAPTER	2
5	5J8102	HOUSING	2
6	4J8425	GASKET	2
7	7F7983	BEARING	8
8	S1571	BOLT	2
	1D4717	NUT	2
	8B4037	WASHER	2
10	3J4407	SEAL	2
11	7J7557	LEVER	1
12	1B8706	KEY	2
13	S1594	BOLT	52
14	3B4506	LOCKWASHER	56
15	5J5729	LEVER	1
16	5J5776	LEVER ASSEM.	1
17	5J5765	ROD ASSEM.	1
18	2H9250	JOINT	2
19	5J5764	ROD ASSEM.	1
20	2H9250	JOINT	2

21	4J3441	ROLLER	1
22	1B4203	NUT	2
	5F9199	PIN	2
23	8S7803	RETAINER	2
24	5J5247	GASKET	1
25	7J779	BRACKET	1
	2J6602	PIN	2
26	1B4204	NUT	2
	3B4507	LOCKWASHER	2
27	2J8262	ROLLER	1
28	7J775	TANK ASSEM.	1
29	6J2237	BOSS	44
	3B8997	FITTING	1
30	8F8998	NUT	1
	4J8252	GLASS	1
	4J8251	GROMMET	1
	4J8250	RETAINER	1
34	4J8265	NUT	4
	6J2459	COVER ASSEM.	1
35	5J5159	COVER	1
36	5J196	STUD	4
37	5J5160	GASKET	1
38	2H3755	BOLT	2
	3B4505	LOCKWASHER	2

119220

5J5724 HYDRAULIC TANK AND VALVE GROUP—Part 3 of 5—Type 2  
 Part of 5K6269, 9K4118, 5K6278 and 2P8033 Hydraulic Arrangements listed on  
 Pages 148A and 148B. Only separate parts serviced. When complete Group  
 is required, order 9J644 shown on Pages 155F through 155K. AN ATTACHMENT

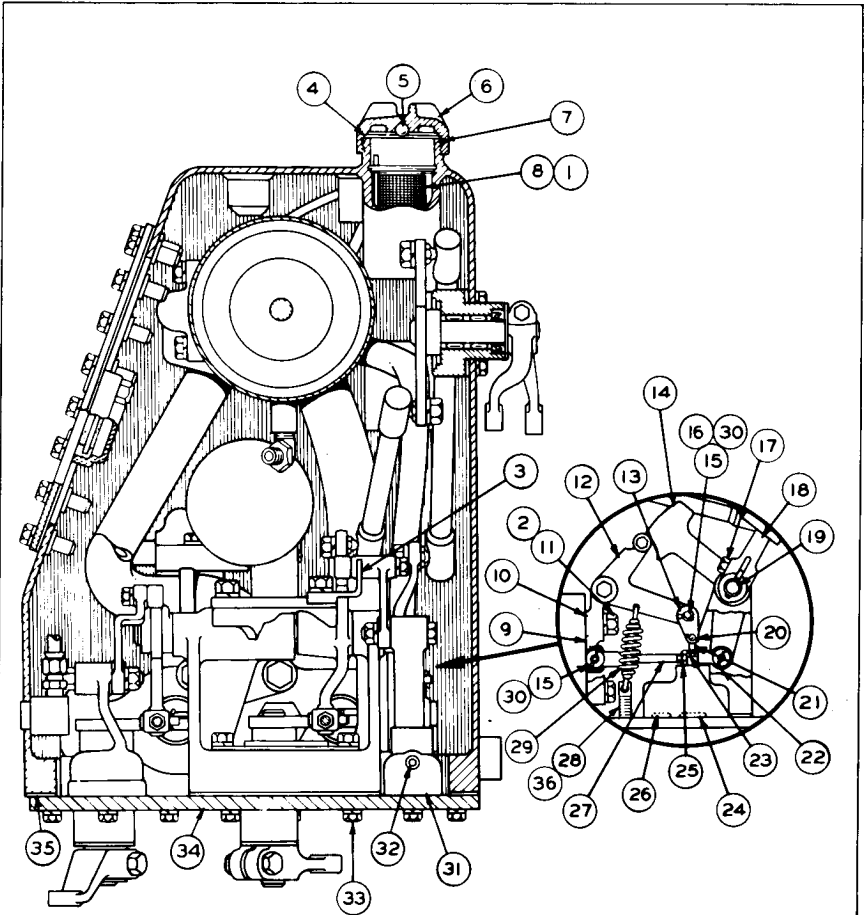

REF. NO.	PART NUMBER	DESCRIPTION	QTY
C 1	5K216	SEAL	1
2	3B4508	LOCKWASHER	2
3	6J4578	STOP	1
4	6H5139	PLATE	1
5	7B6368	BALL	1
6	7H1447	CAP	1
7	9H6454	GASKET	1
C 8	9J3050	STRAINER	1
9	4J519	SEAL	1
10	5J5109	BRACKET	1
11	S1585	BOLT	2
12	5J5071	LEVER	1
13	5J7518	LINK	2
14	5J5111	LEVER	1
15	5F9199	PIN	2
16	7H3912	BUSHING	1
17	S1588	BOLT	1
18	4J7739	LEVER	1
18	1B8706	KEY	1
19	5J5105	SHAFT	1

20	2S975	PIN	1
	3B4607	COTTER PIN	1
21	5J7546	ROD	1
22	1J8489	END	1
23	6F612	NUT	1
24	5F7054	SEAL	1
25	5B9079	NUT	1
26	6F4855	SEAL	1
27	5J5933	ROD	1
	7J6227	EYE SCREW	2
28	1D4717	NUT	2
	5M2894	WASHER	2
29	6H962	SPRING	1
30	8S7803	RETAINER	2
31	5J7958	BODY GROUP	1
32	3D4603	PLUG	1
33	T320	BOLT	52
	3B4507	LOCKWASHER	52
34	8J2333	PLATE	1
35	5J5234	GASKET	1
36	8J6775	SEAL	2

C INDICATES CHANGE

148059

5J5724 HYDRAULIC TANK AND VALVE GROUP—Part 4 of 5—Type 2  
 Part of 5K6269, 9K4118, 5K6278 and 2P8033 Hydraulic Arrangements listed on  
 Pages 148A and 148B. Only separate parts serviced. When complete Group  
 is required, order 9J644 shown on Pages 155F through 155K. AN ATTACHMENT

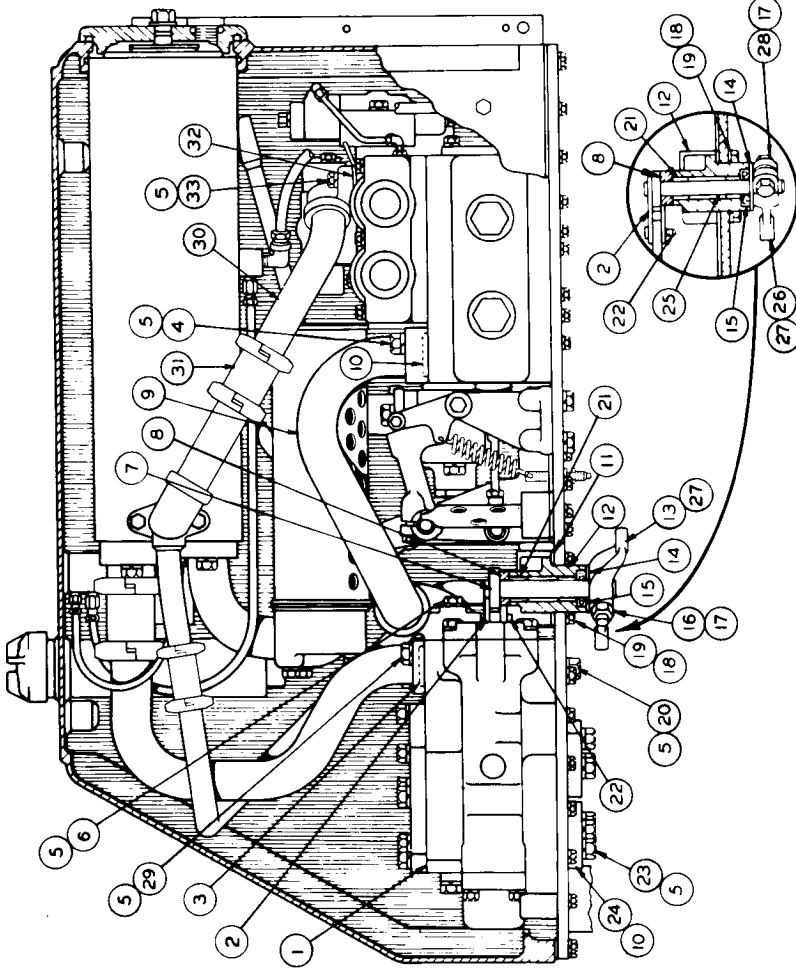

REF. NO.	PART NUMBER	DESCRIPTION	QTY.
1	5J7955	VALVE GROUP.....	1
2	4J7942	LINK.....	4
3	1H9696	SEAL.....	16
4	51587	BOLT.....	2
5	3B4508	LOCKWASHER.....	16
6	9S1366	BOLT.....	2
7	5J916	LEVER ASSEM.....	1
8	2H5746	ADAPTER.....	2
9	5J5151	TUBE ASSEM.....	1
10	4J522	SEAL.....	5
11	4J8425	GASKET.....	2
12	817240	HOUSING.....	2
13	6J2449	LEVER.....	1
14	8B4037	WASHER.....	2
15	3J4407	S'AL.....	2
16	51571	BOLT.....	2
17	1D4717	NUT.....	2
18	3B4506	LOCKWASHER.....	10
19	51588	BOLT.....	8
20	7B3235	BOLT.....	2
21	7F7983	BEARING.....	4
22	5F9199	PIN.....	4
23	8S7803	RETAINER.....	4
24	7H3912	BUSHING.....	4
25	1A1460	BOLT.....	8
26	3K2759	COVER.....	4
27	5J5823	LEVER ASSEM.....	1
28	3J532	LEVER.....	1
29	1B8706	KEY.....	2
30	51590	BOLT.....	2
31	51585	BOLT.....	2
32	7J3570	TUBE ASSEM.....	1
33	5S8062	JOINT.....	1
34	7J3573	GASKET.....	1
35	2B2006	BOLT.....	2

148960

5J5724 HYDRAULIC TANK AND VALVE GROUP—Part 5 of 5—Type 2  
 Part of 5K6269, 9K4118, 5K6278 and 2P8033 Hydraulic Arrangements listed on Pages 148A and 148B  
 5J7955 Valve parts are shown on Page 173. Only separate parts serviced. When complete Group is required,  
 order 9J644 shown on Pages 155F through 155K. AN ATTACHMENT

9J644 HYDRAULIC TANK AND VALVE GROUP—Part 1 of 5—Field Installation  
 Part of 5K6269, 9K4118, 5K6278 and 2P8033 Hydraulic Arrangements listed on Pages 148A and 148B  
 9J643 Control Valve parts are shown on Pages 175C and 175D. AN ATTACHMENT

REF. NO.	PART NUMBER	DESCRIPTION	QTY.
1	T65	BOLT—	2
2	3B4506	LOCKWASHER—	7
3	5J5937	TUBE ASSEM.	1

4	6J2363	TUBE—	1
5	5J5146	BRACKET—	1
6	6H1717	BOLT—	10
7	3B4508	LOCKWASHER—	2
8	4B4280	WASHER—	2
9	6J2362	TUBE—	1
10	5J585	BOLT—	1
11	3B8995	FITTING—	2
12	1F1344	NUT—	2

13	T318	BOLT—	2
	3B4507	LOCKWASHER—	2
	4B4279	WASHER—	2
14	7F58267	SEAL—	1
15	5J588	BOLT—	2
		.....(1.375" Long)	
16	3D9412	GASKET—	1
17	6J236	TUBE ASSEM.	1
18	5J9261	DISC—	1
19	5J5942	GASKET—	1
20	5J6022	TUBE ASSEM.	1
21	3B8996	FITTING—	2
22	8F8097	NUT—	1
23	3B9053	FITTING—	1
24	8F8998	NUT—	1
25	7J748	TUBE—	1
26	5J5942	GASKET—	1
27	5J5108	LEVER—	1
	9J643	CONTROL VALVE GROUP—	1
		(Separate Illustration)	
28	5F9199	PIN—	1
29	8S7803	BETA INER—	1
30	8F3469	SEAL—	4
31	7B3235	BOLT—	4
32	7J6226	BRACKET—	1
33	6H962	SPRING—	1
34	5J5932	ROD—	1
	1J8489	END—	1
35	5B9079	NUT—	1
	5J5110	LEVER—	1
36	1A2209	BOLT—	1
37	8J135	PLUG—	1
38	5J619	BOLT—	2
39	5J595	BOLT—	2
40	8J2288	SPACER—	1
41	8H9819	ADAPTER—	1
	8H9818	GASKET—	2
42	L1143	BOLT—	2
44	4B7739	PLUG—	1
45	4B5167	WASHER—	2

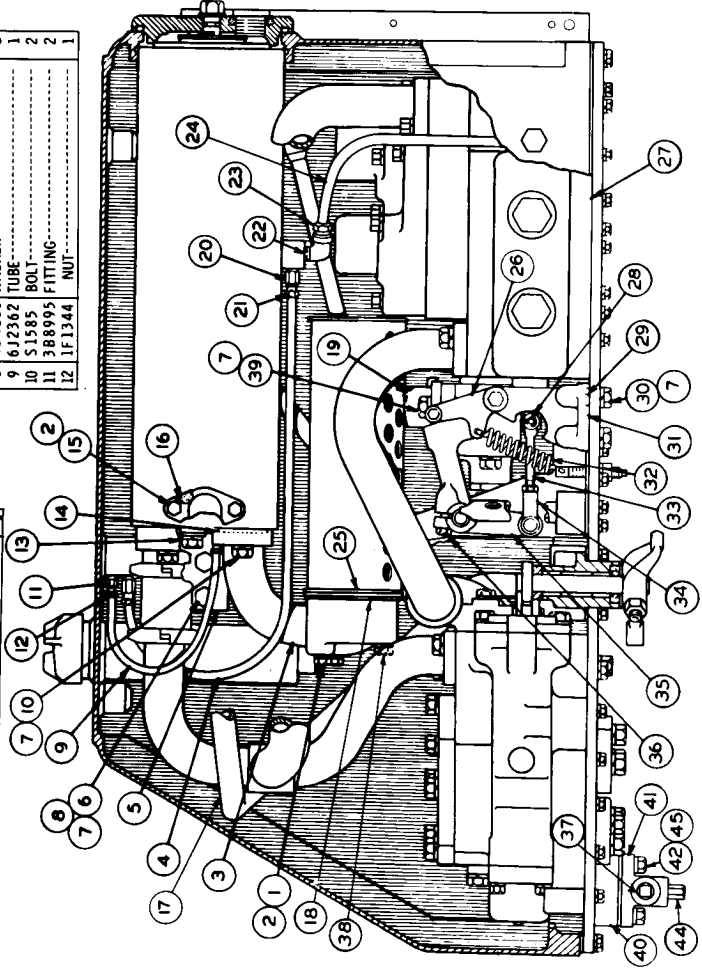

148356

REF. NO.	PART NUMBER	DESCRIPTION	QTY
1	9J664	TUBE ASSEM.	1
2	6L2849	COUPLING	1
3	8J2352	GASKET	2

4	51595	BOLT	2
5	34508	LOCKWASHER	2
6	9J4028	TUBE	1

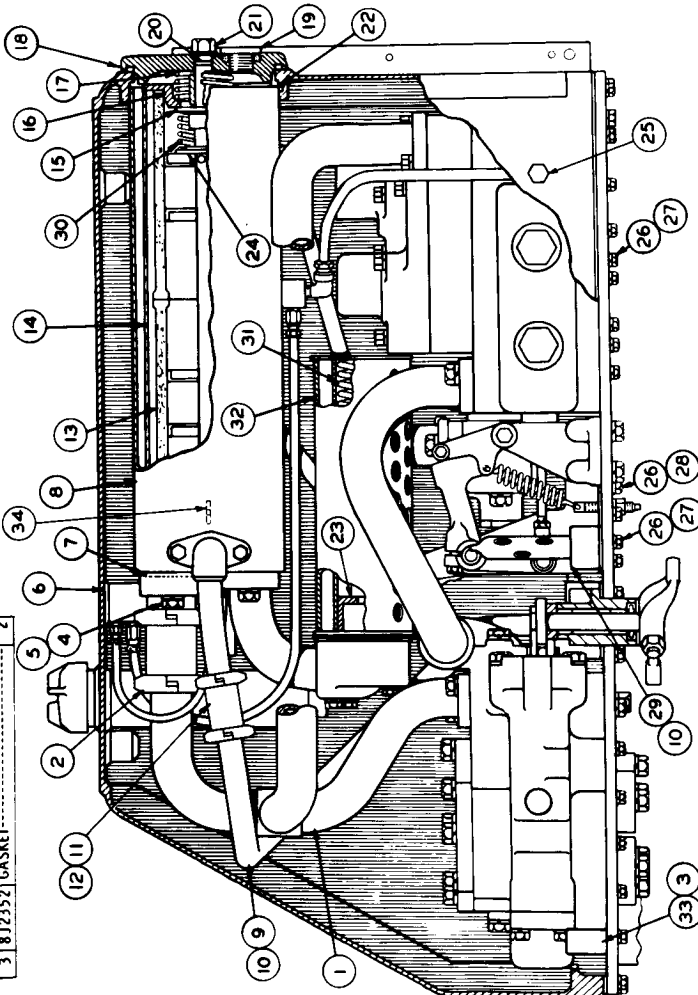

7	5F8000	SEAL	1
8	7J6096	TUBE ASSEM.	1
9	5J5202	TUBE ASSEM.	1
10	5J5166	GASKET	2
11	2S7070	JOINT ASSEM.	1
12	9S2082	SEAL ASSEM.	2
13	4J6064	ELEMENT ASSEM.	2
14	6J3795	SCREEN ASSEM.	1
15	2J918	VALVE	1
16	4L11704	SEAT	1
17	6J2236	SPRING	1
18	7J9197	COVER	1
18A	5L5032	SEAL	1
19	9S8010	PLUG	1
19A	2S4078	SEAL	1
20	6F4855	SEAL	1
21	7J5586	BOLT	1
22	2K4472	SEAL	1
23	6J3908	ORIFICE	1
24	1H1200	PIN	1
		(1.25" Long)	
25	9S4182	PLUG	1
	3J7354	SEAL	1
26	1A2029	BOLT	11
27	384506	LOCKWASHER	8
28	485167	WASHER	3
29	7J772	TUBE ASSEM.	1
30	5J2926	SPRING	1
31	6J3911	SPRING	1
32	7J773	TUBE ASSEM.	1
	8J2381	BLOCK	2
33	3F4479	PIN	2
34	7J5925	PIN	1

146357

9J644 HYDRAULIC TANK AND VALVE GROUP—Part 2 of 5—Field Installation  
 Part of 5K6259, 9K4118, 5K6278 and 2P8033 Hydraulic Arrangements listed on Pages 148A and 148B  
 AN ATTACHMENT



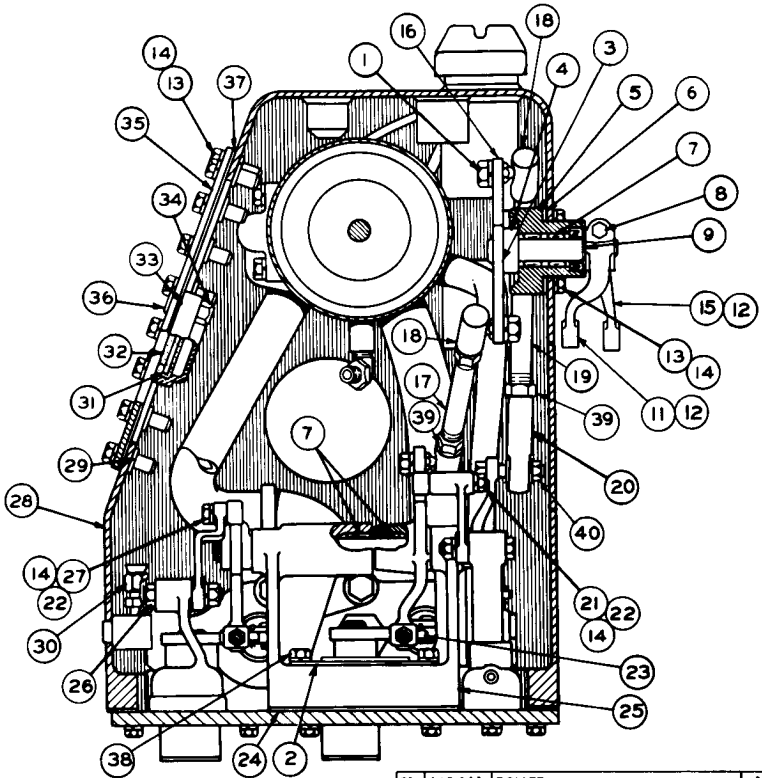

REF. NO.	PART NUMBER	DESCRIPTION	QTY
1	1B4205	NUT-----	3
2	3B4508	LOCKWASHER-----	3
3	6J8118	SCREEN ASSEM.-----	1
4	8J6135	LEVER ASSEM.-----	1
5	2H5746	ADAPTER-----	2
6	5J8102	HOUSING-----	2
7	4J8425	GASKET-----	2
8	9H8751	BEARING-----	8
9	S1571	BOLT-----	2
10	1D4717	NUT-----	2
11	8B4037	WASHER-----	2
12	7J7557	LEVER-----	1
13	1B8706	KEY-----	2
14	S1594	BOLT-----	52
15	3B4506	LOCKWASHER-----	56
16	5J5729	LEVER-----	1
17	9J652	LEVER ASSEM.-----	1
18	8J6101	ROD-----	1
19	8J6171	ROD END ASSEM.-----	3
20	5J7702	ROD-----	1
21	4D4065	ROD END-----	1

21	4J3441	ROLLER-----	1
22	1B4203	NUT-----	2
23	5F9199	PIN-----	2
24	8S7803	RETAINER-----	2
25	5J5247	GASKET-----	1
26	7J779	BRACKET-----	1
27	2J6602	PIN-----	2
28	1B4204	NUT-----	2
29	3B4507	LOCKWASHER-----	2
30	2J8262	ROLLER-----	1
31	9J645	TANK ASSEM.-----	1
32	6J2237	BOSS-----	44
33	3B8997	FITTING-----	1
34	8F8998	NUT-----	1
35	4J8252	GLASS-----	1
36	4J8251	GROMMET-----	1
37	8J6913	RETAINER-----	1
38	4J8265	NUT-----	4
39	9J654	COVER ASSEM.-----	1
40	8J6910	STUD-----	4
41	5J5160	GASKET-----	1
42	2H3755	BOLT-----	2
43	3B4505	LOCKWASHER-----	2
44	1B4430	NUT-----	4
45	S1587	BOLT-----	1
46	1K6872	NUT-----	1

148358

9J644 HYDRAULIC TANK AND VALVE GROUP—Part 3 of 5  
 FIELD INSTALLATION. Part of 5K6269, 9K4118, 5K6278 and 2P8033 Hydraulic  
 Arrangements listed on Pages 148A and 148B. AN ATTACHMENT

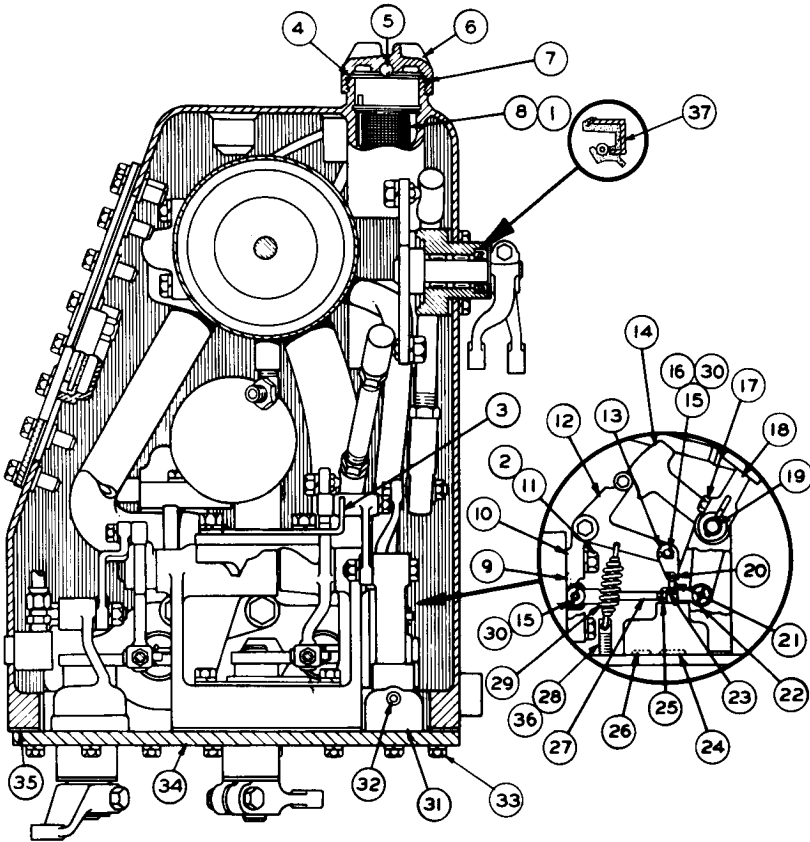

REF. NO.	PART NUMBER	DESCRIPTION	QTY
1	5K216	SEAL-----	1
2	3B4508	LOCKWASHER-----	2
3	6J4578	STOP-----	1
4	6H5139	PLATE-----	1
5	7B6368	BALL-----	1
6	7H1447	CAP-----	1
7	9H6454	GASKET-----	1
8	9J3047	STRAINER-----	1
9	4J519	SEAL-----	1
10	5J5109	BRACKET-----	1
11	51585	BOLT-----	2
12	5J5071	LEVER-----	1
13	5J7518	LINK-----	2
14	5J5111	LEVER-----	1
15	5F9199	PIN-----	2
16	7H3912	BUSHING-----	1
17	51588	BOLT-----	1
18	4J7739	LEVER-----	1
18	1B8706	KEY-----	1
19	9J653	SHAFT-----	1

20	2S975	PIN-----	1
	3B4607	COTTER PIN-----	1
21	5J7546	ROD-----	1
22	1J8489	END-----	1
23	6F612	NUT-----	1
24	5F7054	SEAL-----	1
25	5B9079	NUT-----	1
26	6F4855	SEAL-----	1
27	5J5933	ROD-----	1
	7J6227	EYE SCREW-----	1
28	1D4717	NUT-----	2
	5M2894	WASHER-----	2
29	6H962	SPRING-----	1
30	8S7803	RETAINER-----	2
31	5J7958	BODY GROUP-----	1
32	3D4603	PLUG-----	1
33	T320	BOLT-----	52
	3B4507	LOCKWASHER-----	52
34	8J2333	PLATE-----	1
35	5J5234	GASKET-----	1
36	8J6775	SEAL-----	2
37	3J4407	SEAL-----	2

148359

9J644 HYDRAULIC TANK AND VALVE GROUP—Part 4 of 5  
 FIELD INSTALLATION. Part of 5K6269, 9K4118, 5K6278 and 2P8033 Hydraulic  
 Arrangements listed on Pages 148A and 148B. AN ATTACHMENT

9J644 HYDRAULIC TANK AND VALVE GROUP—Part 5 of 5—Field Installation  
 Part of 5K6269, 9K4118, 5K6278 and 2P8033 Hydraulic Arrangements listed on Pages 148A and 148B  
 9J7955 Valve parts are shown on Page 173. AN ATTACHMENT

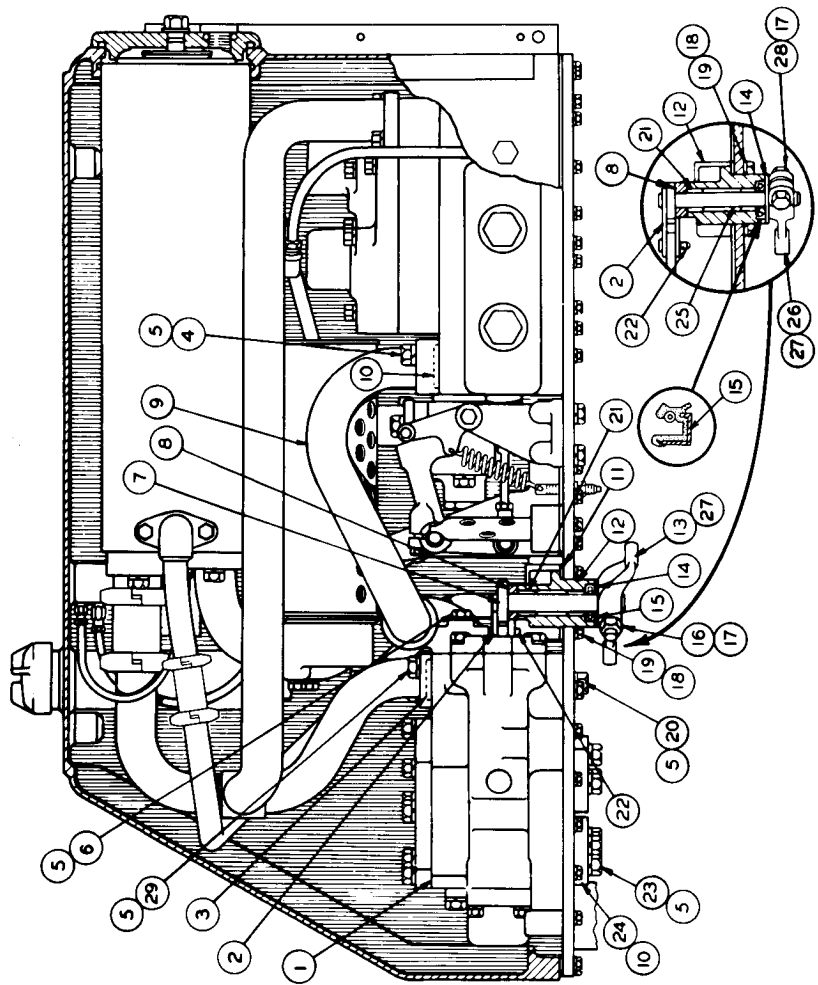

REF. NO.	PART NUMBER	DESCRIPTION	QTY	
1	15177955	VALVE GROUP (Separate Illustration)	1	
2	4J7942	LINK	4	
3	1H9696	SEAL	4	
4	51587	BOLT	2	
5	5B8508	LOCKWASHER	18	
6	9S1366	BOLT	2	
7	8A1633	LEVER ASSEM.	1	
8	2H5746	ADAPTER	2	
9	515151	TUBE ASSEM.	1	
10	41522	SEAL	1	
11	43523	SEAL	5	
12	438425	GASKET	2	
13	8J7240	HOUSING	2	
14	612449	LEVER	1	
15	8B4037	WASHER	1	
16	314407	SEAL	2	
17	51571	BOLT	2	
18	104717	NUT	2	
19	3B4506	LOCKWASHER	10	
20	51588	BOLT	8	
21	7B3235	BOLT	2	
22	9H8751	BEARING	4	
23	5F9199	PIN	4	
24	8S7803	RETAINER	4	
25	7H3912	BUSHING	2	
26	1A1460	BOLT	2	
27	3K2759	COVER	8	
28	8I6132	LEVER ASSEM.	4	
29	3J532	LEVER	1	
30	27	188706	KEY	1
31	28	51590	BOLT	2
32	29	51585	BOLT	4

148560

REF. PART NO.	DESCRIPTION	QTY.
1	165 BOLT.....(3.5" Long)	2
2	51619 BOLT.....(3" Long)	2
3	384506 LOCKWASHER.....	6
4	515937 TUBE ASSEM.....	1

5	612363 TUBE.....	1
6	6H1717 BOLT.....	2
7	384508 LOCKWASHER.....	10
8	484280 WASHER.....	2
9	612362 TUBE.....	1
10	L1143 BOLT.....	2
11	485167 WASHER.....	2
12	IF1344 NUT.....	2

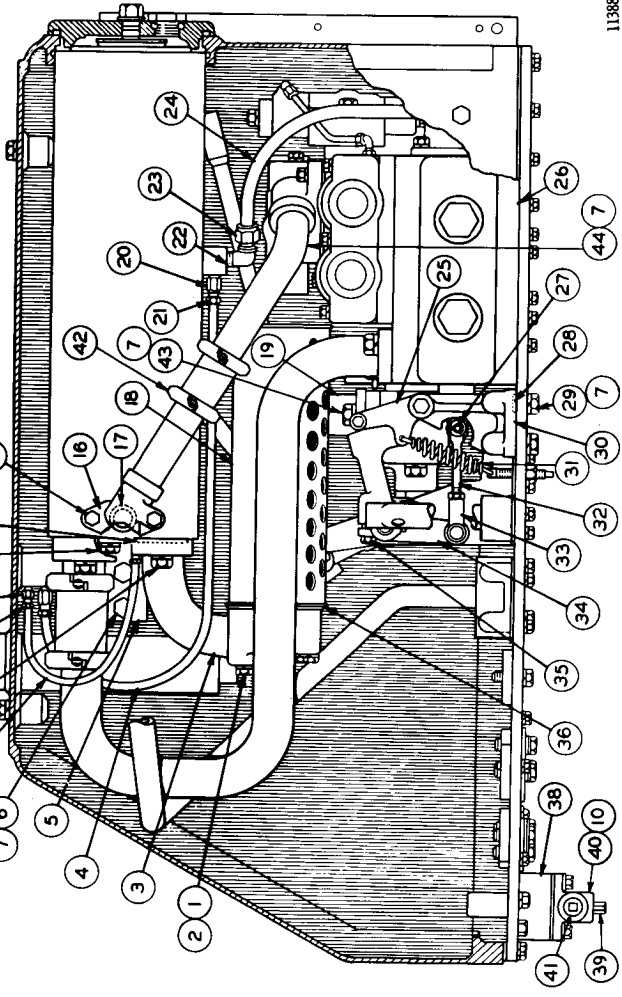

113883

13	IT318 BOLT.....	2
14	384507 LOCKWASHER.....	2
15	484279 WASHER.....	2
16	7F8267 SEAL.....	1
17	381915 BOLT.....(1.375" Long)	1
18	2H5330 BOLT.....(2.875" Long)	1
19	713572 TUBE ASSEM.....	1
20	309412 GASKET.....	1
21	71773 TUBE ASSEM.....	1
22	516022 TUBE ASSEM.....	1
23	388996 FITTING.....	2
24	8F8997 NUT.....	1
25	389053 FITTING.....	1
26	888997 NUT.....	1
27	71748 TUBE.....	1
28	515108 LEVER.....	1
29	517953 CONTROL VALVE GROUP..... (See Separate Illustration)	1
30	5F9199 PIN.....	1
31	857803 RETAINER.....	1
32	8F3469 SEAL.....	4
33	783235 SEAL.....	2
34	716226 BRACKET.....	1
35	6H962 SPRING.....	1
36	515932 ROD.....	1
37	118489 END.....	1
38	589079 NUT.....	1
39	515110 LEVER.....	1
40	1B8706 KEY.....	1
41	1A2209 BOLT.....	1
42	515942 GASKET.....	2
43	519261 DISC.....	1
44	51585 BOLT.....	2
	8J2288 SPACER.....	1
	8H9818 GASKET.....	2
	4B7739 PLUG.....	2
	8H9819 ADAPTER.....	1
	8J135 PLUG.....	1
	7S8062 JOINT.....	1
	51595 BOLT.....	1
	7J3570 TUBE ASSEM.....	2
	7J3573 GASKET.....	1
	282006 BOLT.....	2

HYDRAULIC TANK AND VALVE (5J5722 N/S)—Part 1 of 4  
 Serial No. 11K5051 to 11K5151 inclusive  
 5J7953 Valve parts are shown on Pages 174 & 175

## HYDRAULIC TANK AND VALVE (5J5722 N/S)—Part 2 of 4 Serial No. 11K5051 to 11K5151 inclusive

REF. NO.	PART NUMBER	DESCRIPTION	QTY
1	5J5182	TUBE ASSEM.	1
2	2S7070	JOINT ASSEM.	1
3	6L2849	COUPLING	2
4	51587	BOLT	2
5	3B4508	LOCKWASHER	4
6	5J5157	TUBE ASSEM.	1
7	5F8000	SEAL	1

8	716096	TUBE ASSEM.	1
9	416064	ELEMENT ASSEM.	2
10	613795	SCREEN ASSEM.	1
11	21917	RETAINER	1
11	1H1200	PIN—(1.25" Long)	1
11	715925	PIN—(1 1/4" Long)	1

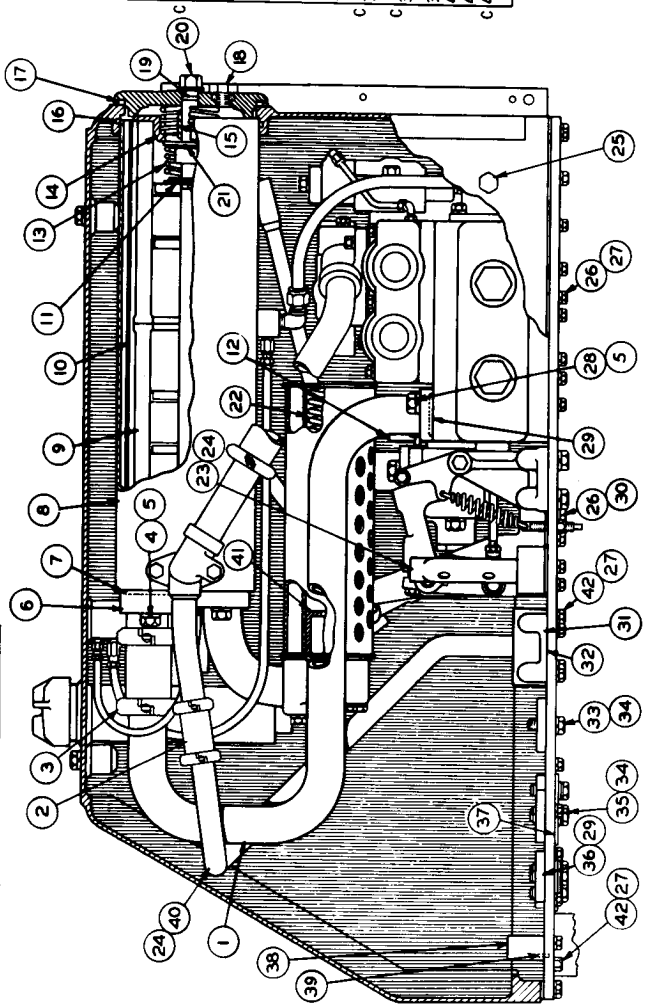

12	614578	STOP	1
13	512926	SPRING	1
14	411704	SEAT	1
15	612236	SPRING	1
16	2K4472	SEAL	1
17	719197	COVER	1
17	5L5052	SEAL	1
18	4938010	PLUG	1
18	2S4078	SEAL	1
19	6F4855	SEAL	1
20	715586	BOLT	1
21	21918	VALVE	1
22	613911	SPRING	1
22	71772	TUBE ASSEM.	1
24	515166	GASKET	1
24	4934182	PLUG	2
25	317354	SEAL	1
26	1A2029	BOLT	1
27	3B4506	LOCKWASHER	1
28	51585	BOLT	12
29	1H9696	SEAL	5
30	4B5167	WASHER	5
31	712852	COVER	3
32	418425	GASKET	2
33	51595	BOLT	2
34	5B5689	WASHER	2
35	783235	BOLT	10
36	319296	COVER	8
37	1J18467	COVER	5
37	211799	GASKET	4
38	812381	BLOCK	4
38	812352	GASKET	2
39	3F4479	PIN	2
40	515202	TUBE ASSEM.	2
41	6J3908	ORIFICE	1
42	51588	BOLT	1
42	51588	BOLT	8

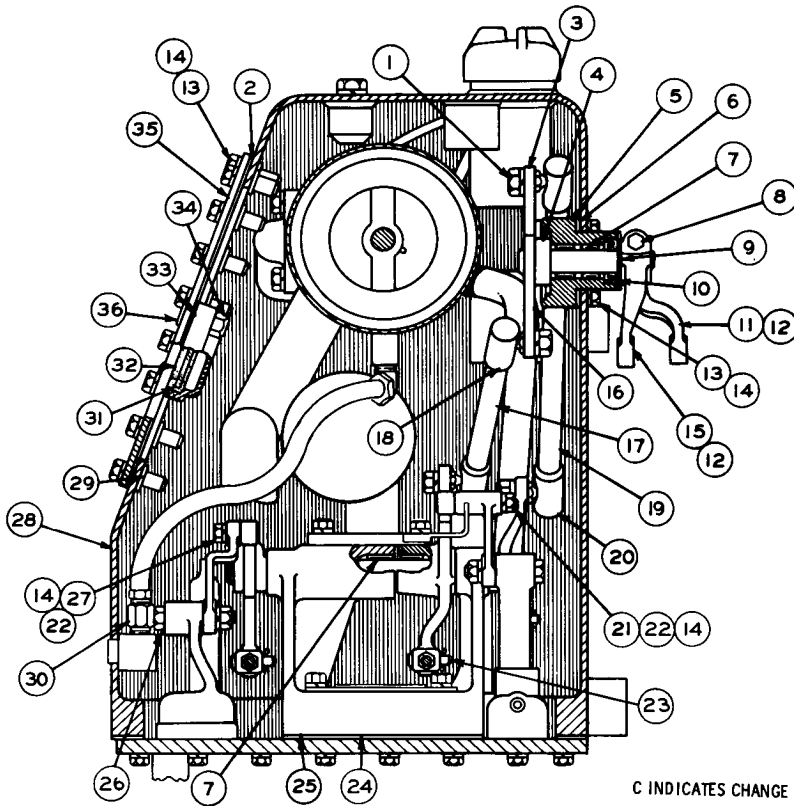

C INDICATES CHANGE

REF NO	PART NUMBER	DESCRIPTION	QTY
1	1B4205	NUT-----	4
	3B4508	LOCKWASHER-----	4
2	5J5160	GASKET-----	1
3	5J5774	LEVER ASSEM.-----	1
4	2H5746	ADAPTER-----	2
5	5J8102	HOUSING-----	2
6	4J8425	GASKET-----	2
7	7F7983	BEARING-----	8
8	S1571	BOLT-----	2
	1D4717	NUT-----	2
9	8B4037	WASHER-----	2
10	3J4407	SEAL-----	2
11	7J9557	LEVER-----	1
12	1B8706	KEY-----	2
13	S1594	BOLT-----	52
14	3B4506	LOCKWASHER-----	54
15	5J5729	LEVER-----	1
16	5J5776	LEVER ASSEM.-----	1
17	5J5765	ROD ASSEM.-----	1
18	2H9250	JOINT-----	2
19	5J5764	ROD ASSEM.-----	1
20	2H9250	JOINT-----	2

21	4J3441	ROLLER-----	1
22	1B4203	NUT-----	2
C 23	5F9199	PIN-----	2
	8S7803	PIN-----	2
24	5J5247	RETAINER-----	1
25	7J779	BRACKET-----	1
	2J6602	PIN-----	2
26	1B4204	NUT-----	2
	3B4507	LOCKWASHER-----	2
27	2J8262	ROLLER-----	1
28	7J775	TANK ASSEM.-----	1
29	6J2237	BOSS-----	44
30	3B8997	FITTING-----	1
	8F8998	NUT-----	1
31	4J8252	GLASS-----	1
32	4J8251	GROMMET-----	1
33	4J8250	RETAINER-----	1
34	4J8265	NUT-----	4
	6J2459	COVER ASSEM.-----	1
35	5J5159	COVER-----	1
36	5J96	STUD-----	4

113885

HYDRAULIC TANK AND VALVE (5J5722 N/S)—Part 3 of 4  
Serial No. 11K5051 to 11K5151 inclusive

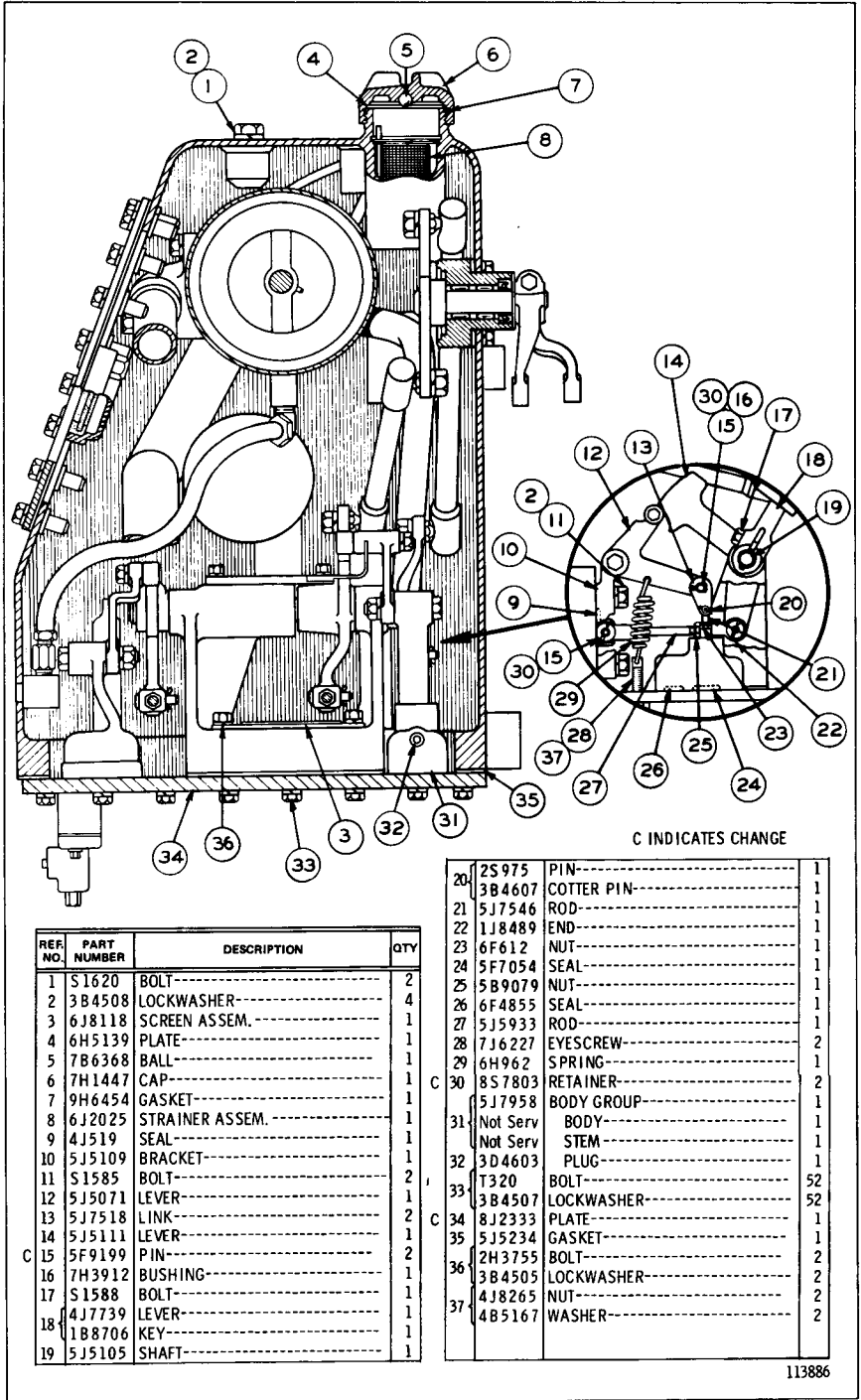

C INDICATES CHANGE

REF. NO.	PART NUMBER	DESCRIPTION	QTY
1	S1620	BOLT	2
2	3B4508	LOCKWASHER	4
3	6J8118	SCREEN ASSEM.	1
4	6H5139	PLATE	1
5	7B6368	BALL	1
6	7H1447	CAP	1
7	9H6454	GASKET	1
8	6J2025	STRAINER ASSEM.	1
9	4J519	SEAL	1
10	5J5109	BRACKET	1
11	S1585	BOLT	2
12	5J5071	LEVER	1
13	5J7518	LINK	2
14	5J5111	LEVER	1
15	5F9199	PIN	2
16	7H3912	BUSHING	1
17	S1588	BOLT	1
18	4J7739	LEVER	1
18	1B8706	KEY	1
19	5J5105	SHAFT	1

20	2S975	PIN	1
21	3B4607	COTTER PIN	1
21	5J7546	ROD	1
22	1J8489	END	1
23	6F612	NUT	1
24	5F7054	SEAL	1
25	5B9079	NUT	1
26	6F4855	SEAL	1
27	5J5933	ROD	1
28	7J6227	EYESCREW	2
29	6H962	SPRING	1
30	8S7803	RETAINER	2
30	5J7958	BODY GROUP	1
31	Not Serv	BODY	1
31	Not Serv	STEM	1
32	3D4603	PLUG	1
32	T320	BOLT	52
33	3B4507	LOCKWASHER	52
34	8J2333	PLATE	1
35	5J5234	GASKET	1
36	2H3755	BOLT	2
36	3B4505	LOCKWASHER	2
37	4J8265	NUT	2
37	4B5167	WASHER	2

113886

HYDRAULIC TANK AND VALVE (5J5722 N/S)—Part 4 of 4  
Serial No. 11K5051 to 11K5151 inclusive

REQ. NO.	PART NUMBER	DESCRIPTION	QTY
1	1665	BOLT.....(3.5" Long)	2
2	151619	BOLT.....(3" Long)	2
3	384506	LOCKWASHER.....	6
4	1515937	TUBE ASSEM.....	1

4	1612363	TUBE.....	1
5	515146	BRACKET.....	1
6	641717	BOLT.....	2
7	384508	LOCKWASHER.....	10
8	484280	WASHER.....	2
9	1612362	TUBE.....	2
10	11143	BOLT.....	1
11	485167	WASHER.....	2
12	1F1344	NUT.....	1

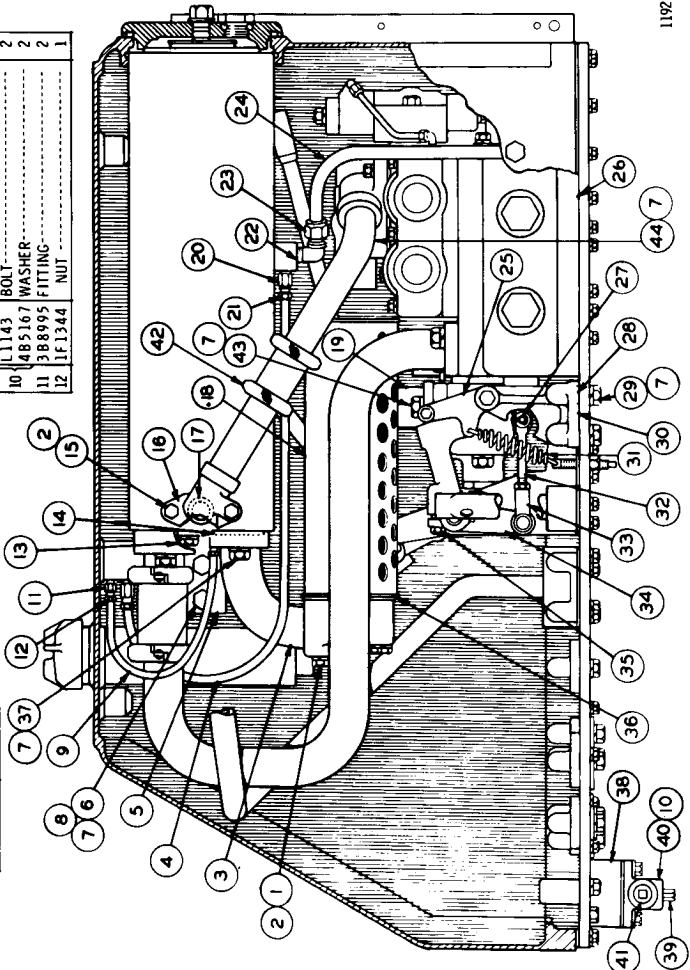

119210

13	1318	BOLT.....	2
13	384507	LOCKWASHER.....	2
14	484279	WASHER.....	1
14	7F8267	SEAL.....	2
15	381915	BOLT.....(1.375" Long)	1
15	7H45300	BOLT.....(2.875" Long)	1
16	7J3572	TUBE ASSEM.....	1
17	3D9412	GASKET.....	1
18	7J773	TUBE ASSEM.....	1
19	5J6022	TUBE ASSEM.....	1
20	388996	FITTING.....	2
21	8F8997	NUT.....	1
22	3B9053	FITTING.....	1
23	8B8997	NUT.....	1
24	7J748	TUBE.....	1
25	5J5108	LEVER.....	1
26	5J7953	CONTROL VALVE GROUP..... (Separate Illustration)	1
27	5F9199	PIN.....	1
27	8S7803	RETAINER.....	1
28	8F3469	SEAL.....	4
29	7B3235	BOLT.....	2
30	7J6226	BRACKET.....	1
31	6H962	SPRING.....	1
32	5J5932	ROD.....	1
33	1J8489	END NUT.....	1
33	589079	NUT.....	1
34	5J5110	LEVER.....	1
34	1B8706	KEY.....	1
35	1A2209	BOLT.....	1
36	5J5942	GASKET.....	2
36	5J9261	DISC.....	2
37	51585	BOLT.....	2
38	8J2288	SPACER.....	2
38	8H9818	GASKET.....	2
39	487739	PLUG.....	1
40	8H9819	ADAPTER.....	1
41	8J135	PLUG.....	1
42	7S8062	JOINT.....	1
43	51595	BOLT.....	2
43	7J3570	TUBE ASSEM.....	1
44	7J3573	GASKET.....	2
44	2B2006	BOLT.....	2

HYDRAULIC TANK AND VALVE (5J5722 N/S)—Part 1 of 4—Type 1  
 Serial No. 11K5152 to 11K6202 inclusive  
 5J7953 Control Valve parts are shown on Pages 174 and 175



HYDRAULIC TANK AND VALVE (5J5722 N/S)—Part 2 of 4—Type 1  
Serial No. 11K5152 to 11K6202 inclusive

REF. NO.	PART NUMBER	DESCRIPTION	QTY
1	5J5182	TUBE ASSEM.	1
2	2S7070	JOINT ASSEM.	1
3	6L2849	COUPLING	2
4	5L587	BOLT	2
5	3B4508	LOCKWASHER	12
6	5J5157	TUBE ASSEM.	1
7	1J78000	SEAL	1

8	7J5096	TUBE ASSEM.	1
9	4J6064	ELEMENT ASSEM.	2
10	6J3795	SCREEN ASSEM.	1
11	2J917	RETAINER	1
11	1H1200	PIN—3.18 cm(1.25 in.) long	1
11	7J5925	PIN—2.54 cm(1.00 in.) long	1

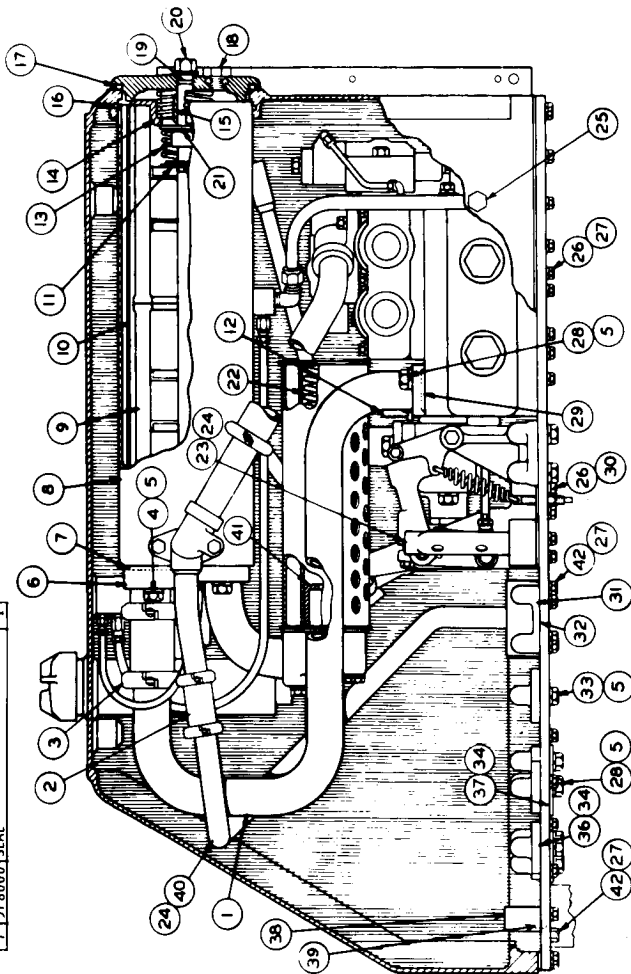

12	6J4578	STOP	1	
13	5J2926	SPRING	1	
14	4J1704	SEAT	1	
15	6J2236	SPRING	1	
16	2K4472	SEAL	1	
17	7J9197	COVER	1	
17	5L5032	SEAL	1	
18	9S8010	PLUG	1	
18	2S52078	SEAL	1	
19	6F4855	SEAL	1	
20	7J5586	BOLT	1	
21	2J918	VALVE	1	
22	6J3911	SPRING	1	
23	7J772	TUBE ASSEM.	1	
24	5J5166	GASKET	2	
25	9S4182	PLUG	1	
25	3J7354	SEAL	1	
26	1A2029	BOLT	7	
27	3B4506	LOCKWASHER	12	
C	28	5L585	BOLT	10
C	29	1H9696	SEAL	1
30	4B5167	WASHER	3	
31	7J2852	COVER	2	
32	4J8425	GASKET	2	
C	33	1B3235	BOLT	9
C	34	2J1799	GASKET	3
C	36	8J6129	COVER	5
C	37	1J8467	COVER	4
38	8J2381	BLOCK	2	
38	18J2352	GASKET	2	
39	3F4479	PIN	2	
40	5J5202	TUBE ASSEM.	1	
41	6J3908	ORIFICE	1	
42	5L588	BOLT	8	

C INDICATES CHANGE

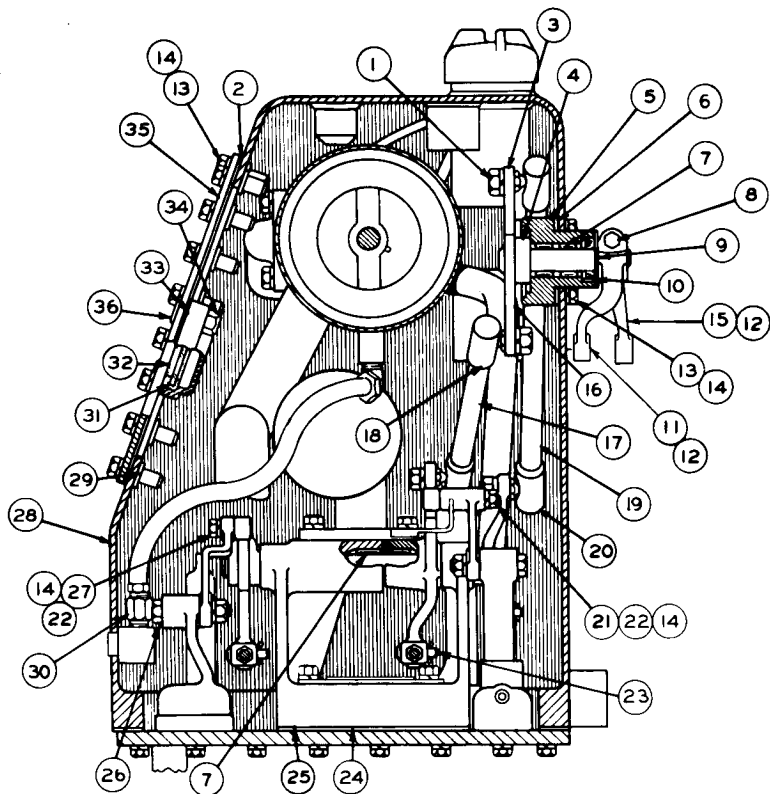

REF NO.	PART NUMBER	DESCRIPTION	QTY
1	1B4205	NUT-----	4
1	3B4508	LOCKWASHER-----	4
2	5J5160	GASKET-----	1
3	5J5774	LEVER ASSEM.-----	1
4	2H5746	ADAPTER-----	2
5	5J8102	HOUSING-----	2
6	4J8425	GASKET-----	2
7	7F7983	BEARING-----	8
8	51571	BOLT-----	2
8	1D4717	NUT-----	2
9	8B4037	WASHER-----	2
10	3J4407	SEAL-----	2
11	7J7557	LEVER-----	1
12	1B8706	KEY-----	2
13	51594	BOLT-----	52
14	3B4506	LOCKWASHER-----	54
15	5J5729	LEVER-----	1
16	5J5776	LEVER ASSEM.-----	1
17	5J5765	ROD ASSEM.-----	1
18	2H9250	JOINT-----	2
19	5J5764	ROD ASSEM.-----	1
20	2H9250	JOINT-----	2

21	4J3441	ROLLER-----	1
22	1B4203	NUT-----	2
23	5F9199	PIN-----	2
23	8S7803	PIN-----	2
24	5J5247	RETAINER-----	1
25	7J779	BRACKET-----	1
	2J6602	PIN-----	2
26	1B4204	NUT-----	2
	3B4507	LOCKWASHER-----	2
27	2J8262	ROLLER-----	1
28	7J775	TANK ASSEM.-----	1
29	6J2237	BOSS-----	44
30	3B8997	FITTING-----	1
	8F8998	NUT-----	1
31	4J8252	GLASS-----	1
32	4J8251	GROMMET-----	1
33	4J8250	RETAINER-----	1
34	4J8265	NUT-----	4
	6J2459	COVER ASSEM.-----	1
35	5J5159	COVER-----	1
36	5J96	STUD-----	4

119212

HYDRAULIC TANK AND VALVE (5J5722 N/S)—Part 3 of 4—Type 1

Serial No. 11K5152 to 11K6202 inclusive

Note: 6J468 Indicator Assembly is available

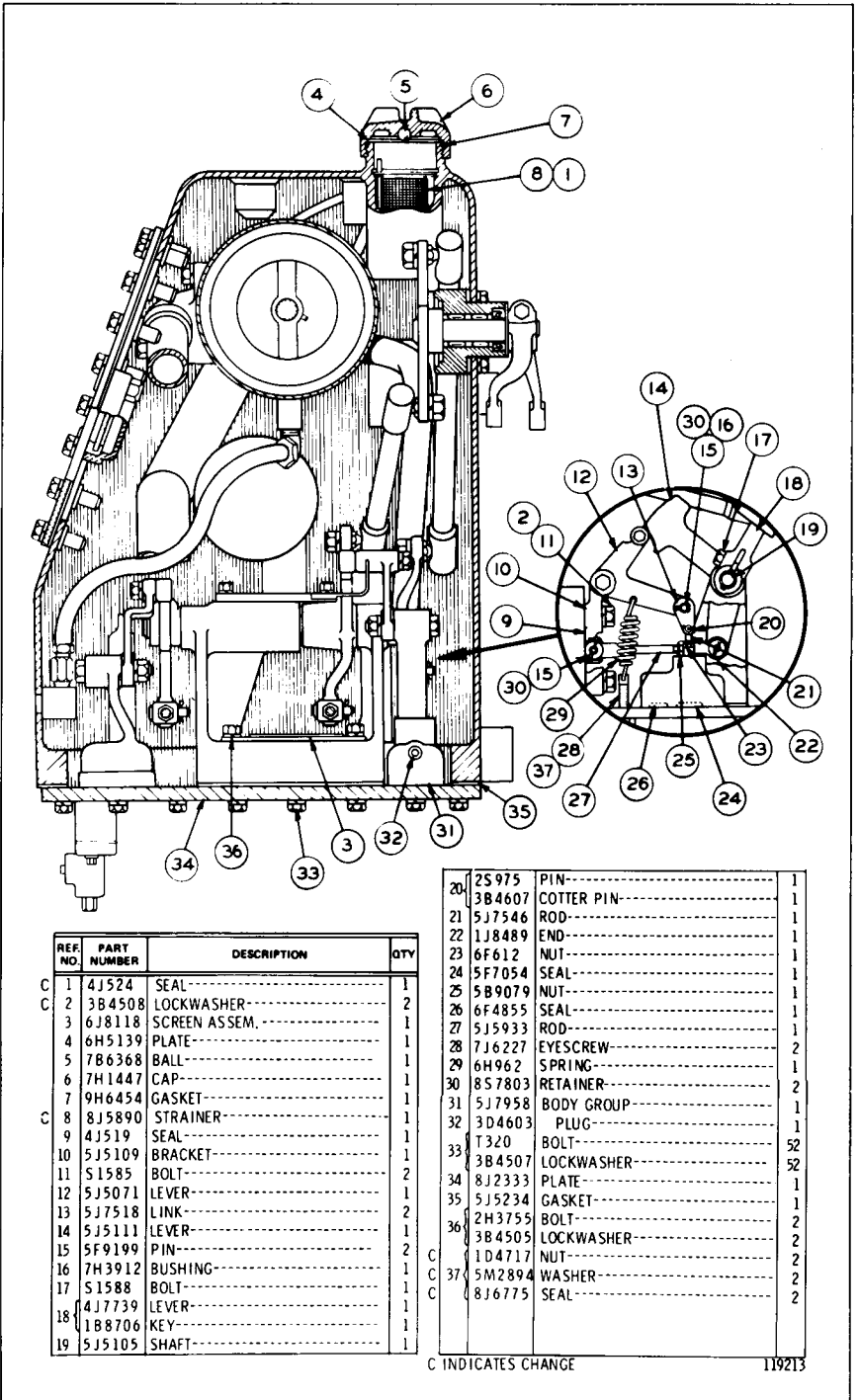

REF. NO.	PART NUMBER	DESCRIPTION	QTY	
1	4J524	SEAL	1	
C	2	3B4508	LOCKWASHER	2
C	3	6J8118	SCREEN ASSEM.	1
	4	6H5139	PLATE	1
	5	7B6368	BALL	1
	6	7H1447	CAP	1
	7	9H6454	GASKET	1
C	8	8J5890	STRAINER	1
	9	4J519	SEAL	1
	10	5J5109	BRACKET	1
	11	5I585	BOLT	2
	12	5J5071	LEVER	1
	13	5J7518	LINK	2
	14	5J5111	LEVER	1
	15	5F9199	PIN	2
	16	7H3912	BUSHING	1
	17	5I588	BOLT	1
	18	4J7739	LEVER	1
	18	1B8706	KEY	1
	19	5J5105	SHAFT	1

20	2S975	PIN	1	
	3B4607	COTTER PIN	1	
21	5J7546	ROD	1	
22	1J8489	END	1	
23	6F612	END	1	
24	5F7054	SEAL	1	
25	5B9079	NUT	1	
	26	6F4855	SEAL	1
	27	5I5933	ROD	1
	28	7J6227	EYESCREW	2
	29	6H962	SPRING	1
	30	8S7803	RETAINER	2
	31	5J7958	BODY GROUP	1
	32	3D4603	PLUG	1
		T320	BOLT	52
	33	3B4507	LOCKWASHER	52
	34	8J2333	PLATE	1
	35	5J5234	GASKET	1
	36	2H3755	BOLT	2
		3B4505	LOCKWASHER	2
		1D4717	NUT	2
C	37	5M2894	WASHER	2
C		8J6775	SEAL	2

C INDICATES CHANGE

119213

HYDRAULIC TANK AND VALVE (5J5722 N/S)—Part 4 of 4—Type 1  
Serial No. 11K5152 to 11K6202 inclusive

REF. PART NO.	DESCRIPTION	QTY
1	165 BOLT—(3.5" Long)	2
2	151619 BOLT—(3" Long)	2
3	384506 LOCKWASHER	6
4	1515937 TUBE ASSEM.	1

4	612363 TUBE	1
5	515146 BRACKET	1
6	611717 BOLT	2
7	384508 LOCKWASHER	10
8	484280 WASHER	2
9	612362 TUBE	1
10	611143 BOLT	2
11	485167 WASHER	2
12	388995 FITTING	2
13	1F1344 NUT	1

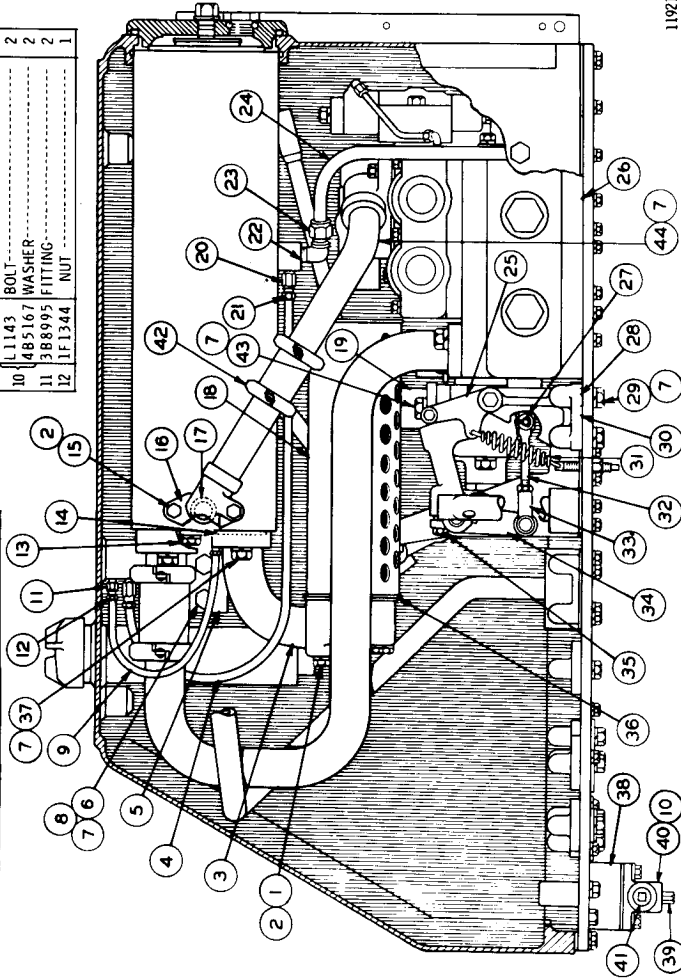

1	1318 BOLT	2
2	384507 LOCKWASHER	2
3	484279 WASHER	1
4	7F8267 SEAL	2
5	381915 BOLT—(1.375" Long)	1
6	2H5330 BOLT—(2.875" Long)	1
7	7J3572 TUBE ASSEM.	1
8	3D9412 GASKET	1
9	7J3773 TUBE ASSEM.	1
10	5J6022 TUBE ASSEM	1
11	388996 FITTING	2
12	8F8997 NUT	1
13	389053 FITTING	1
14	888997 NUT	1
15	7J1748 TUBE	1
16	5J5108 LEVER	1
17	5J7953 CONTROL VALVE GROUP—(Separate Illustration)	1
18	5F9199 PIN	1
19	8S7803 RETAINER	1
20	8F3469 SEAL	4
21	7B3235 BOLT	4
22	7J6226 BRACKET	2
23	6H962 SPRING	1
24	5J5932 ROD	1
25	1J8489 END	1
26	5B9079 NUT	1
27	5J5110 LEVER	1
28	188706 KEY	1
29	1A2209 BOLT	1
30	5J5942 GASKET	2
31	5J9261 DISC	2
32	51585 BOLT	2
33	8J2288 SPACER	2
34	8H9818 GASKET	2
35	4B7739 PLUG	2
36	8H9819 ADAPTER	1
37	8J1135 PLUG	1
38	7S8062 JOINT	1
39	51595 BOLT	2
40	7J3570 TUBE ASSEM.	1
41	7J3573 GASKET	2
42	2B2006 BOLT	1

119210

HYDRAULIC TANK AND VALVE (5J5722 N/S)—Part 1 of 4—Type 2  
 Serial No. 11K5152 to 11K6202 inclusive  
 5J7953 Control Valve parts are shown on Pages 174 and 175

## HYDRAULIC TANK AND VALVE (5J5722 N/S)—Part 2 of 4—Type 2 Serial No. 11K5152 to 11K6202 Inclusive

REF. NO.	PART NUMBER	DESCRIPTION	QTY.
1	5J5182	TUBE ASSEM.	1
2	257076	JOINT ASSEM.	1
3	6L2849	COUPLING	2
4	51587	BOLT	2
5	3B4508	LOCKWASHER	12
6	5J5157	TUBE ASSEM.	1
7	5F8000	SEAL	1

8	7J6096	TUBE ASSEM.	2
9	4I6064	ELEMENT ASSEM.	1
10	6I3795	SCREEN ASSEM.	1
11	21917	RETAINER	1
11	1H1200	PIN—3.18 cmt., 25 in., long	1
11	7J5925	PIN—2.54 cmt., 00 in., long	1

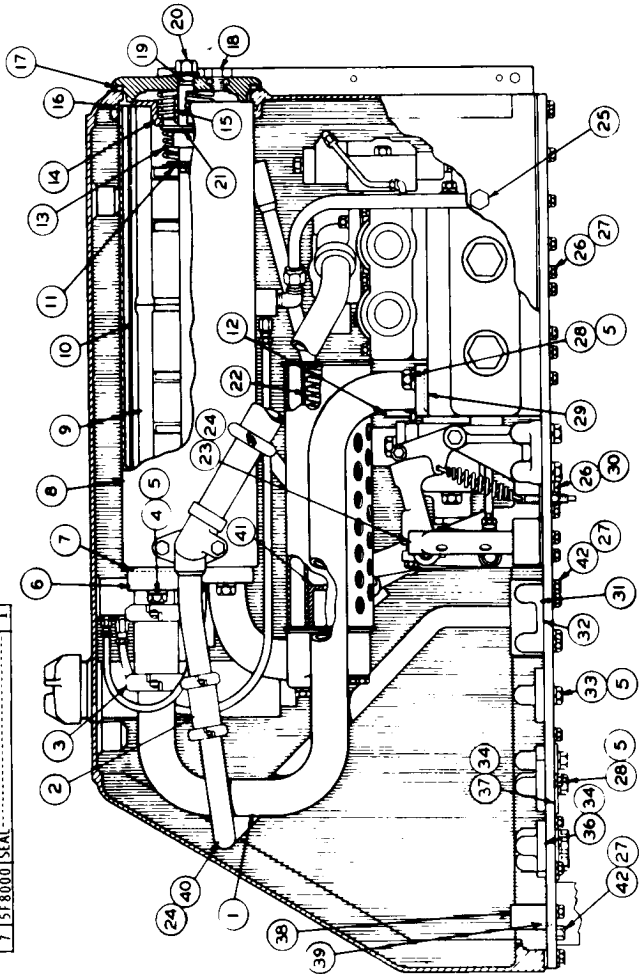

12	6J4578	STOP	1
13	5J2926	SPRING	1
14	4J1704	SEAT	1
15	6J2236	SPRING	1
16	2K4472	SEAL	1
17	7J1917	COVER	1
17	5L5032	SEAL	1
18	958010	PLUG	1
18	254078	SEAL	1
19	6F4855	SEAL	1
20	7J5586	BOLT	1
21	21918	VALVE	1
22	6J3911	SPRING	1
23	7J772	TUBE ASSEM.	1
24	5J5166	GASKET	2
25	954182	PLUG	1
25	3J7354	SEAL	1
26	1A2029	BOLT	12
27	3B4506	LOCKWASHER	10
28	5L585	BOLT	2
29	1H9696	SEAL	1
30	4B5167	WASHER	3
31	7J2852	COVER	2
32	4I8425	GASKET	2
33	7B3235	BOLT	3
34	211709	GASKET	9
36	8I6129	COVER	5
37	1J8467	COVER	4
38	8J2381	BLOCK	2
38	8J2352	GASKET	2
39	3F4479	PIN	1
40	5J5202	TUBE ASSEM.	1
41	6J3908	ORIFICE	1
42	5L588	BOLT	8

C INDICATES CHANGE

150727

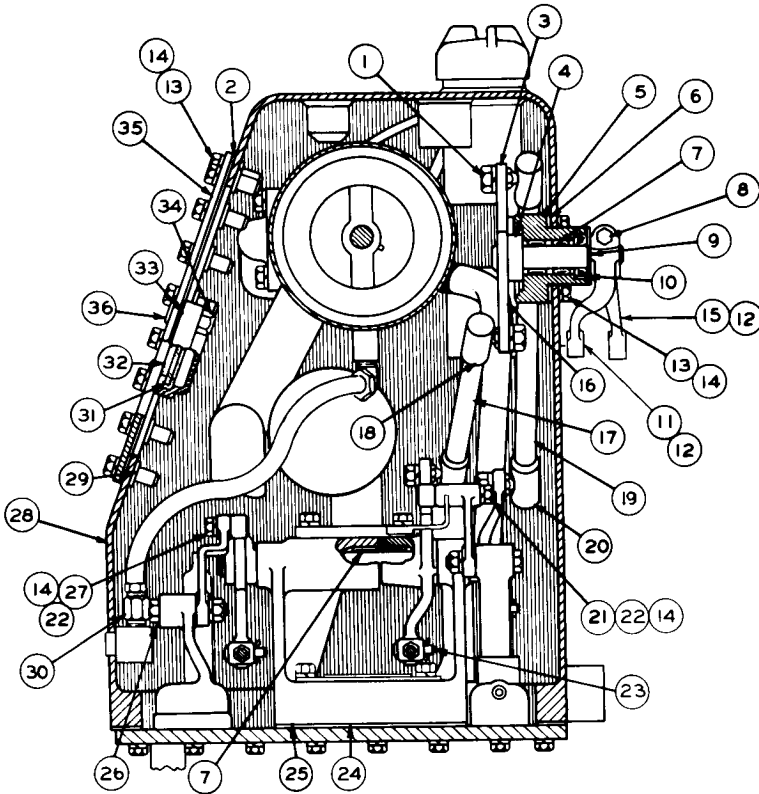

REF NO	PART NUMBER	DESCRIPTION	QTY
1	1B4205	NUT-----	4
	3B4508	LOCKWASHER-----	4
2	5J5160	GASKET-----	1
3	5J5774	LEVER ASSEM.-----	1
4	2H5746	ADAPTER-----	2
5	5J8102	HOUSING-----	2
6	4J8425	GASKET-----	2
7	7F7983	BEARING-----	8
8	51571	BOLT-----	2
	1D4717	NUT-----	2
9	8B4037	WASHER-----	2
10	314407	SEAL-----	2
11	7J7557	LEVER-----	1
12	1B8706	KEY-----	2
13	51594	BOLT-----	1
14	3B4506	LOCKWASHER-----	54
15	5J5729	LEVER-----	1
16	5J5776	LEVER ASSEM.-----	1
17	5J5765	ROD ASSEM.-----	1
18	2H9250	JOINT-----	2
19	5J5764	ROD ASSEM.-----	1
20	2H9250	JOINT-----	2

21	4J3441	ROLLER-----	1
22	1B4203	NUT-----	2
23	5F9199	PIN-----	2
	8S7803	PIN-----	2
24	5J5247	RETAINER-----	1
25	7J779	BRACKET-----	1
	2J6602	PIN-----	2
26	1B4204	NUT-----	2
	3B4507	LOCKWASHER-----	2
27	2J8262	ROLLER-----	1
28	7J775	TANK ASSEM.-----	1
29	6J2237	BOSS-----	44
30	3B8997	FITTING-----	1
	8F8998	NUT-----	1
31	4J8252	GLASS-----	1
32	4J8251	GROMMET-----	1
33	4J8250	RETAINER-----	1
34	4J8265	NUT-----	4
	6J2459	COVER ASSEM.-----	1
35	5J5159	COVER-----	1
36	5J96	STUD-----	4

119212

HYDRAULIC TANK AND VALVE (5J5722 N/S)—Part 3 of 4—Type 2  
 Serial No. 11K5152 to 11K6202 inclusive  
 Note: 6J468 Indicator Assembly is available

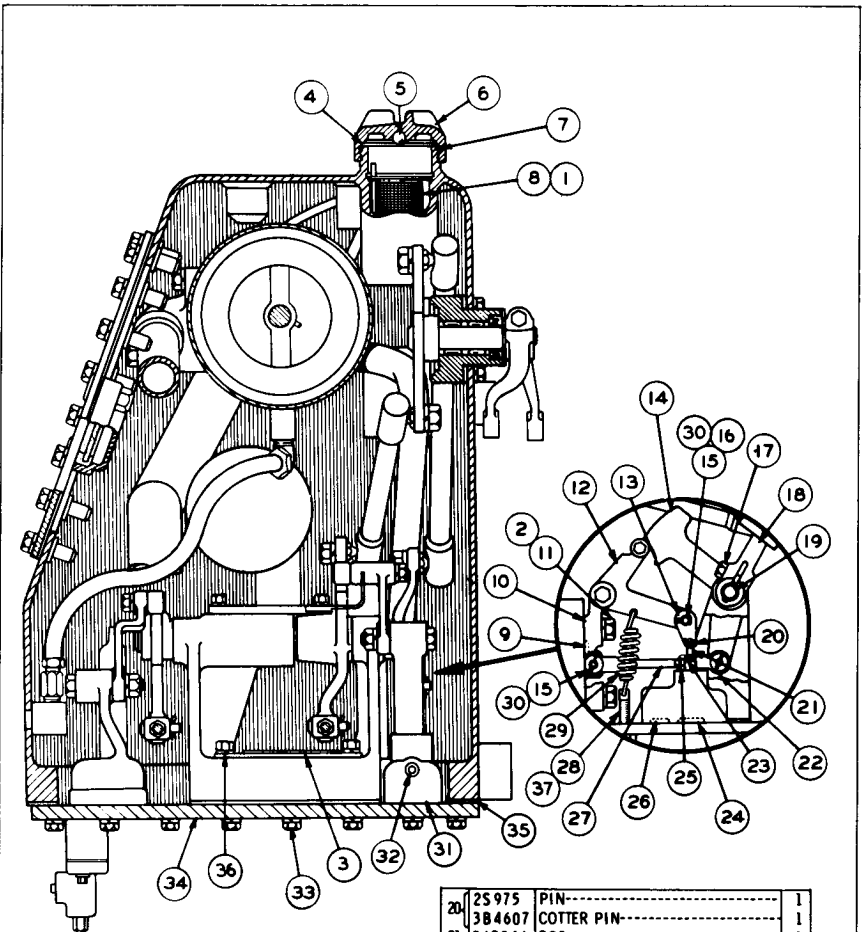

REF. NO.	PART NUMBER	DESCRIPTION	QTY
C 1	5K216	SEAL-----	1
2	3B4508	LOCKWASHER-----	2
3	6J8118	SCREEN ASSEM.-----	1
4	6H5139	PLATE-----	1
5	7B6368	BALL-----	1
6	7H1447	CAP-----	1
7	9H6454	GASKET-----	1
C 8	9J3050	STRAINER-----	1
9	4J519	SEAL-----	1
10	5J5109	BRACKET-----	1
11	5I585	BOLT-----	2
12	5J5071	LEVER-----	1
13	5J7518	LINK-----	2
14	5J5111	LEVER-----	2
15	5F9199	PIN-----	2
16	7H3912	BUSHING-----	1
17	5I588	BOLT-----	1
18	4J7739	LEVER-----	1
18	1B8706	KEY-----	1
19	5J5105	SHAFT-----	1

20	2S975	PIN-----	1
	3B4607	COTTER PIN-----	1
21	5J7546	ROD-----	1
22	1J8489	END-----	1
23	6F612	NUT-----	1
24	5F7054	SEAL-----	1
25	5B9079	NUT-----	1
26	6F4855	SEAL-----	1
27	5J5933	ROD-----	1
28	7J6227	EYESCREW-----	2
29	6H962	SPRING-----	1
30	8S7803	RETAINER-----	2
31	5J7958	BODY GROUP-----	1
32	3D4603	PLUG-----	1
33	T320	BOLT-----	52
	3B4507	LOCKWASHER-----	52
34	8J2333	PLATE-----	1
35	5J5234	GASKET-----	1
36	2H3755	BOLT-----	2
	3B4505	LOCKWASHER-----	2
	1D4717	NUT-----	2
37	5M2894	WASHER-----	2
	8J6775	SEAL-----	2

C INDICATES CHANGE

148901

HYDRAULIC TANK AND VALVE (5J5722 N/S)—Part 4 of 4—Type 2  
Serial No. 11K5152 to 11K6202 inclusive

REF. NO.	PART NUMBER	DESCRIPTION	QTY
1	612363	TUBE	1
2	515146	BRACKET	1
3	6H1717	BOLT	2
4	3B4508	LOCKWASHER	12
5	4B4280	WASHER	2
6	612362	TUBE	1
7	515995	BOLT	2
8	3B88995	FITTING	2
9	1F1344	NUT	1

REF. NO.	PART NUMBER	DESCRIPTION	QTY
1	165	BOLT—(3.5" Long)	2
2	51619	BOLT—(3" Long)	2
3	3B4506	LOCKWASHER	6
4	515937	TUBE ASSEM.	1

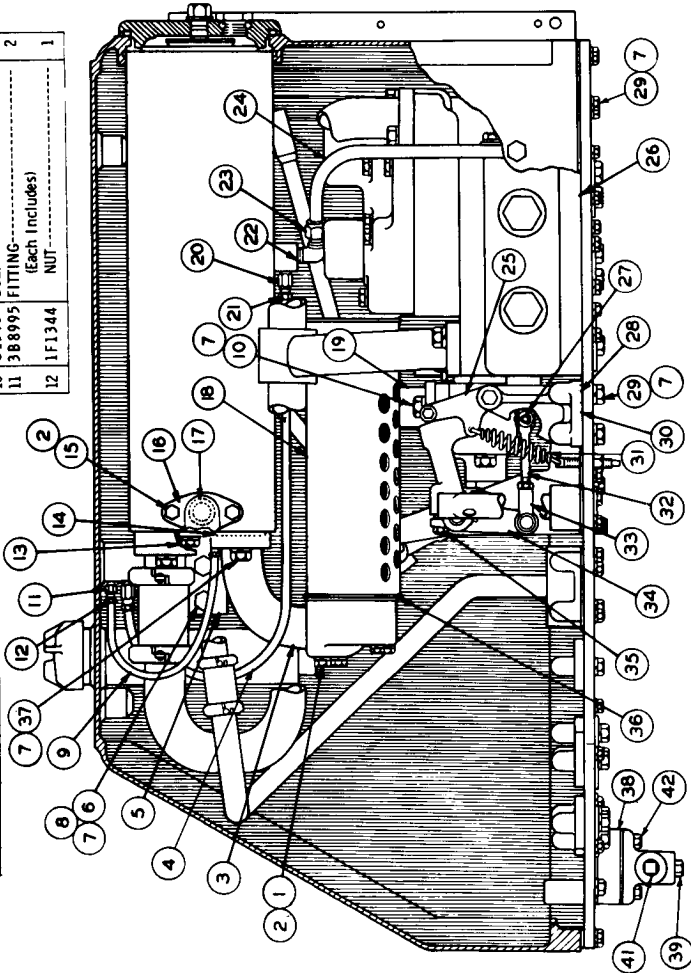

13	1318	BOLT	2
14	3B4507	LOCKWASHER	2
15	4B4279	WASHER	2
16	7F8267	SEAL	1
17	51588	BOLT	2
18	61236	TUBE ASSEM.	1
19	3D9A12	GASKET	1
20	3D9A12	TUBE ASSEM.	1
21	5J6022	TUBE ASSEM.	2
22	3B88996	FITTING	2
23	8F8997	NUT	1
24	3B9053	FITTING	1
25	8F8998	NUT	1
26	7J748	TUBE	1
27	5J5108	LEVER	1
28	9J643	CONTROL VALVE GROUP	1
29	5F9199	PIN	1
30	8S7803	RETAINER	1
31	8F3469	SEAL	4
32	7B3235	SEAL	4
33	7J6226	BRACKET	1
34	6H962	SPRING	1
35	5J5932	ROD	1
36	1J8489	END	1
37	4B9079	NUT	1
38	515110	LEVER	1
39	1B8706	KEY	1
40	1A2209	BOLT	1
41	5J5942	GASKET	2
42	5J9261	DISC	1
43	51585	BOLT	2
44	812288	SPACER	1
45	8H9818	GASKET	2
46	4B7739	PLUG	1
47	8H9819	ADAPTER	1
48	8J135	PLUG	1
49	8L1143	BOLT	1
50	4B5167	WASHER	2

148902

9J642 HYDRAULIC TANK AND VALVE GROUP—Part 1 of 4  
 Serial No. 11K6203—Up  
 9J643 Valve parts are shown on Pages 175C and 175D



9J642 HYDRAULIC TANK AND VALVE GROUP—Part 2 of 4  
Serial No. 11K6203—Up

REF. NO.	PART NUMBER	DESCRIPTION	QTY.
1	9J660	TUBE ASSEM.	1
2	2S7070	JOINT ASSEM. (Includes)	1
3	9S2082	SEAL	2
4	6L2849	JOINT ASSEM. (Includes)	1
5	2N8198	SEAL ASSEM.	1

4	51587	BOLT	2
5	3B4508	LOCKWASHER	14
6	5J5157	TUBE ASSEM.	1
7	5F8000	SEAL	1
8	7J6096	TUBE ASSEM.	1
9	4J6064	ELEMENT ASSEM.	2
10	6J3795	SCREEN ASSEM.	1

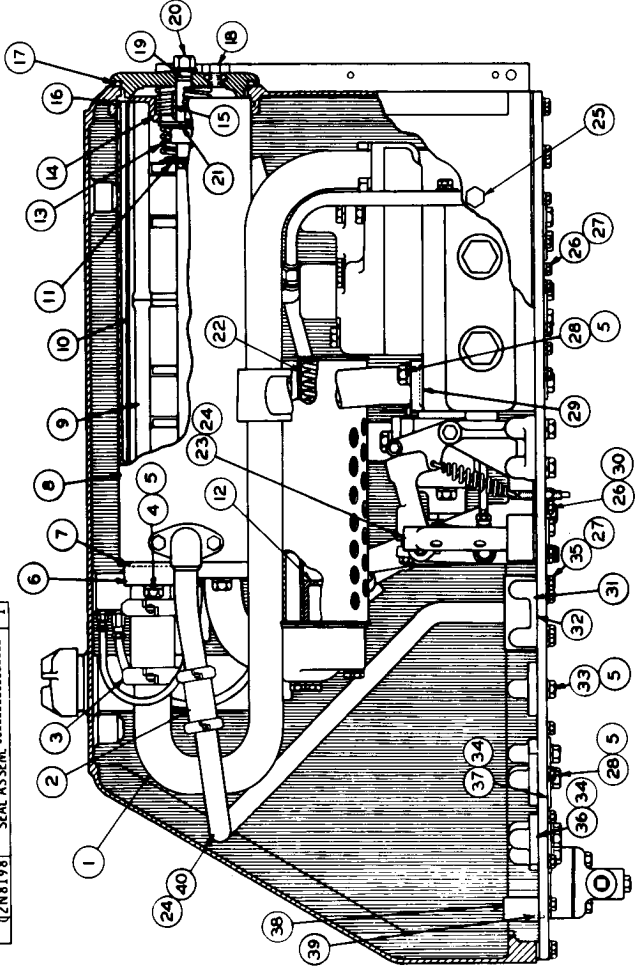

12	2J917	RETAINER	1
11	1H1208	PIN—1.25 in. (3.175 cm) long	1
10	47J5925	PIN—1 in. (2.75 cm) long	1
13	6J3908	ORIFICE	1
12	5J2926	SPRING	1
14	4H1704	SEAT	1
15	6J2236	SPRING	1
16	2K4472	SEAL	1
17	47J9187	COVER	1
18	5L5032	SEAL	1
19	9S8010	PLUG	1
20	2S4078	SEAL	1
19	6F4855	SEAL	1
20	7J5586	BOLT	1
21	2J918	VALVE	1
22	6J3911	SPRING	1
23	7J772	TUBE ASSEM.	2
24	5J5166	GASKET	1
25	9S4182	PLUG	1
25	3J7354	SEAL	1
26	1A2029	BOLT	11
27	3B4506	LOCKWASHER	16
28	51585	BOLT	12
28	1H9696	SEAL	1
30	4B5167	WASHER	3
31	7J2852	COVER	2
32	4J8425	GASKET	2
33	7B3235	BOLT	2
34	2J1799	GASKET	9
35	51588	BOLT	8
36	8J6129	COVER	5
37	1J8467	COVER	4
38	8J2381	BLOCK	2
38	8J2352	GASKET	2
39	3F4479	PIN	2
40	5J5202	TUBE ASSEM.	1

148903

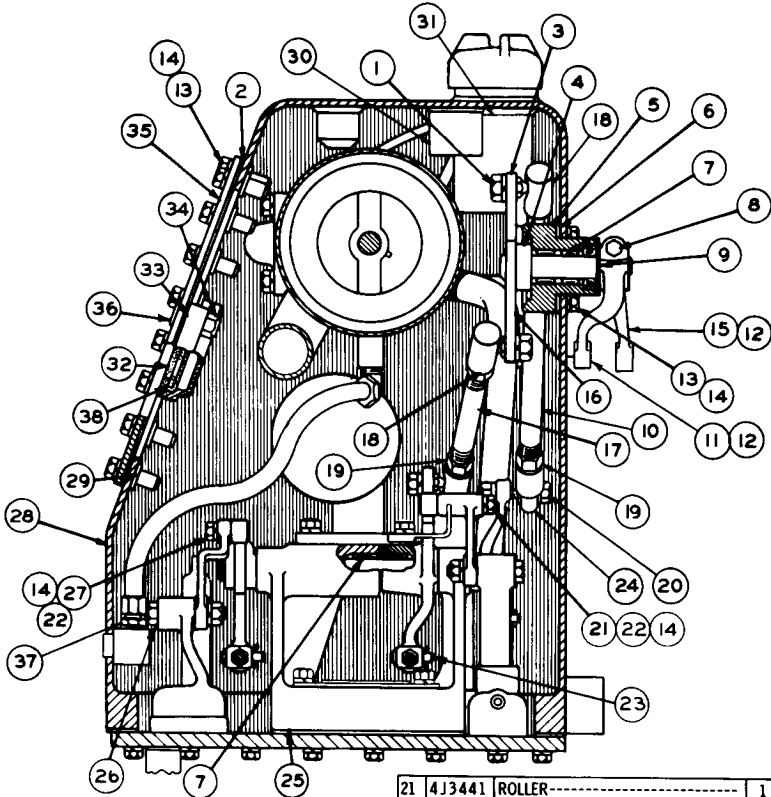

REF. NO.	PART NUMBER	DESCRIPTION	QTY
1	1B4205	NUT	4
	3B4508	LOCKWASHER	4
2	5J5160	GASKET	1
3	9J652	LEVER ASSEM.	1
4	2H5746	ADAPTER	2
5	5J8102	HOUSING	2
6	4J8425	GASKET	2
7	9H8751	BEARING	8
8	51571	BOLT	2
	1D4717	NUT	2
9	8B4037	WASHER	2
10	5J7702	ROD	1
11	7J7557	LEVER	1
12	1B8706	KEY	2
13	51594	BOLT	52
14	3B4506	LOCKWASHER	54
15	5J5729	LEVER	1
16	8J6135	LEVER ASSEM.	1
17	8J6101	ROD	1
18	8J6171	ROD END ASSEM.	3
19	1B4430	NUT	4
20	51587	BOLT	1
	1K6872	NUT	1

21	4J3441	ROLLER	1
22	1B4203	NUT	2
23	5F9199	PIN	2
	8S7803	RETAINER	2
24	4J4065	ROD END	1
	7J779	BRACKET	1
25	5J5247	GASKET	1
	2J6602	PIN	2
26	1B4204	NUT	2
	3B4507	LOCKWASHER	2
27	2J8262	ROLLER	1
28	9J645	TANK ASSEM.	1
		(Includes)	
29	6J2237	BOSS	44
	6J2333	BOSS	1
31	9J648	FILLER	1
32	4J8251	GROMMET	1
33	8J6913	RETAINER	1
34	4J8265	NUT	4
35	9J654	COVER ASSEM.	1
		(Includes)	
36	8J6910	STUD	4
	3B8997	FITTING	1
37		(Includes)	
	8F8998	NUT	1
38	4J8252	GLASS	1

148904

9J642 HYDRAULIC TANK AND VALVE GROUP—Part 3 of 4

Serial No. 11K6203—Up

Note: 6J468 Indicator Assembly is available

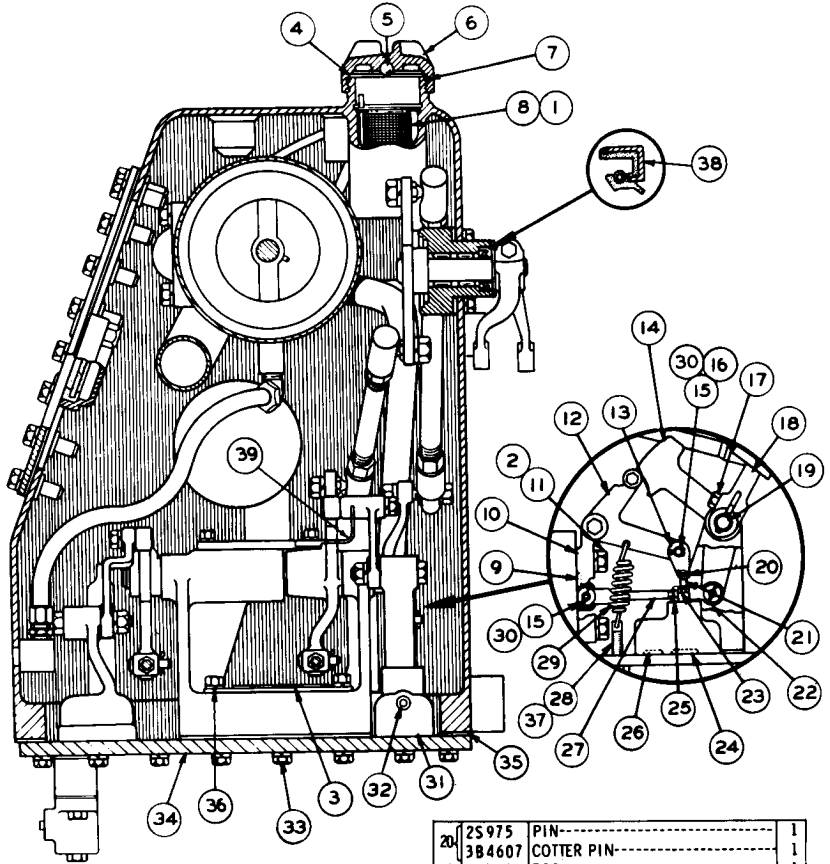

REF. NO.	PART NUMBER	DESCRIPTION	QTY
1	5K216	SEAL	1
2	3B4508	LOCKWASHER	2
3	6J8118	SCREEN ASSEM.	1
4	6H5139	PLATE	1
5	7B6368	BALL	1
6	7H1447	CAP	1
7	9H6454	GASKET	1
8	9J3047	STRAINER	1
9	4J519	SEAL	1
10	5J5109	BRACKET	1
11	S1585	BOLT	2
12	5J5071	LEVER	1
13	5J7518	LINK	2
14	5J5111	LEVER	1
15	5F9199	PIN	2
16	7H3912	BUSHING	1
17	S1588	BOLT	1
18	4J7739	LEVER	1
18	1B8706	KEY	1
19	9J653	SHAFT	1

20	2S975	PIN	1
	3B4607	COTTER PIN	1
21	5J7546	ROD	1
22	1J8489	END	1
23	6F612	NUT	1
24	5F7054	SEAL	1
25	5B9079	NUT	1
26	6F4855	SEAL	1
27	5J5933	ROD	1
28	7J6227	EYESCREW	2
29	6H962	SPRING	1
30	8S7803	RETAINER	2
31	5J7958	BODY GROUP	1
32	3D4603	PLUG	1
	T320	BOLT	52
33	3B4507	LOCKWASHER	52
34	8J2333	PLATE	1
35	5J5234	GASKET	1
	2H3755	BOLT	2
	3B4505	LOCKWASHER	2
	1D4717	NUT	2
37	5M2894	WASHER	2
	8J6775	SEAL	2
38	3J4407	SEAL	2
39	6J4578	STOP	1

148905

REF NO.	PART NUMBER	DESCRIPTION	QTY
1	165	BOLT	2
2	384506	LOCKWASHER	1
3	515937	TUBE ASSEM.	6

4	612363	TUBE	(.25" O. D.)	1
5	515146	BRACKET		1
6	6H1717	BOLT		2
7	384508	LOCKWASHER		12
8	484280	WASHER	(.25" O. D.)	2
9	612362	TUBE		2
10	515385	BOLT		2
11	388995	FITTING		2
12	1F1344	NUT		1

13	T318	BOLT		2
14	384507	LOCKWASHER		2
15	484279	WASHER		1
16	7F8267	SEAL		1
17	245330	BOLT	(2.875" Long)	1
18	381915	BOLT	(1.375" Long)	1
19	7J3572	TUBE ASSEM.		1
20	3D9412	GASKET		1
21	7J773	TUBE ASSEM.		1
22	516022	TUBE		1
23	388996	FITTING		2
24	8F8997	NUT		1
25	389053	FITTING		1
26	8F8998	NUT		1
27	71748	TUBE		1
28	5J5108	LEVER		1
29	517953	CONTROL VALVE GROUP	(Separate Illustration)	1
30	5F9199	PIN		1
31	857803	RETAINER		1
32	8F3469	SEAL		4
33	7B3235	BOLT		4
34	7J6226	BRACKET		2
35	6H982	SPRING		1
36	5J5932	ROD		1
37	418922	END		1
38	589079	NUT		1
39	515110	LEVER		1
40	188706	KEY		1
41	1A2209	BOLT		1
42	519261	DISC		1
43	515942	GASKET		1
44	51619	BOLT		2
45	51595	BOLT		2
46	258062	JOINT		2
47	7J3570	TUBE ASSEM.		1
48	7J3573	GASKET		1
49	282006	BOLT		2

119214

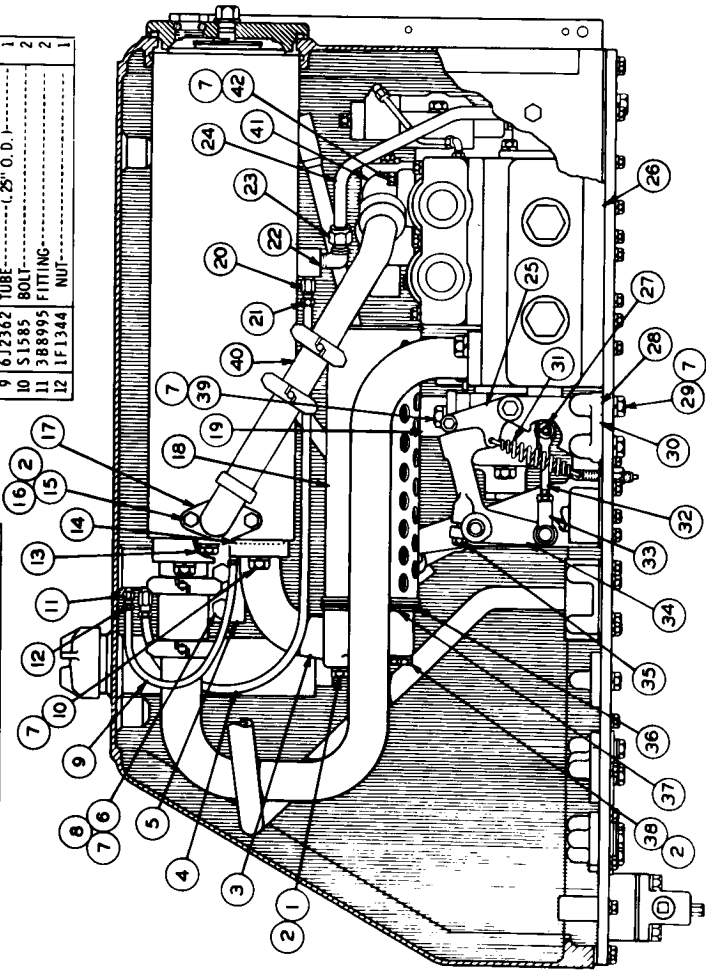

6J7041 HYDRAULIC TANK AND VALVE GROUP—Part 1 of 4—Type 1  
 Part of 6K5440 Hydraulic Arrangement listed on Page 150. 5J7953 Valve parts are shown  
 on Pages 174 through 175B. AN ATTACHMENT

6J7041 HYDRAULIC TANK AND VALVE GROUP—Part 2 of 4—Type 1  
 Part of 6K5440 Hydraulic Arrangement listed on Page 150  
 AN ATTACHMENT

REF. NO.	PART NUMBER	DESCRIPTION	QTY
1	515182	TUBE ASSEM.	1
2	257070	JOINT ASSEM.	1
2	952082	SEAL ASSEM.	2
3	6L2849	COUPLING ASSEM.	1
3	2N8198	SEAL ASSEM.	2
4	51587	BOLT	2
5	3R4508	LOCKWASHER	12
6	515157	TUBE ASSEM.	1

7	5F8000	SEAL	1
8	716096	TUBE ASSEM.	1
9	416064	ELEMENT ASSEM.	1
10	613795	SCREEN ASSEM.	1
11	21917	RETAINER	1
11	1H1200	PIN—(L.25" Long)	1
11	715925	PIN—(L.125" Long)	1

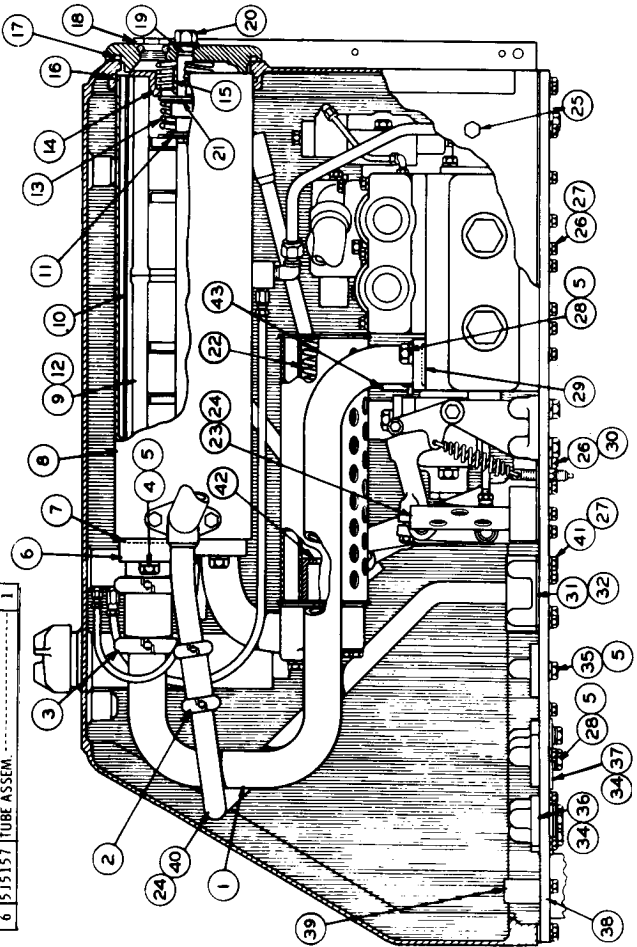

12	617096	ELEMENT ASSEM.	1
13	512926	SPRING	1
14	411704	SEAT	1
15	612236	SPRING	1
16	2K4472	SEAL	1
17	719197	COVER	1
18	515032	SEAL	1
18	958010	PLUG	2
19	254078	SEAL	2
19	6F4855	SEAL	1
20	715586	BOLT	1
21	21918	VALVE	1
22	613011	SPRING	1
23	71772	TUBE ASSEM.	1
24	515166	GASKET	2
25	954182	PLUG	1
25	3J7354	SEAL	1
26	1A2029	BOLT	11
27	3R4506	LOCKWASHER	16
C 28	1H9696	SEAL	10
C 28	51585	BOLT	3
C 30	485167	WASHER	3
31	712852	COVER	2
32	4J8425	GASKET	2
C 34	211799	GASKET	9
C 35	783235	BOLT	3
C 36	8J1629	COVER	5
37	1J8476	COVER	4
38	3F4479	PIN	4
39	8J238	BLOCK	2
39	8J235	GASKET	2
40	515202	TUBE ASSEM.	2
41	51588	BOLT	3
42	6J3908	ORIFICE	1
43	6J4578	STOP	1

C INDICATES CHANGE

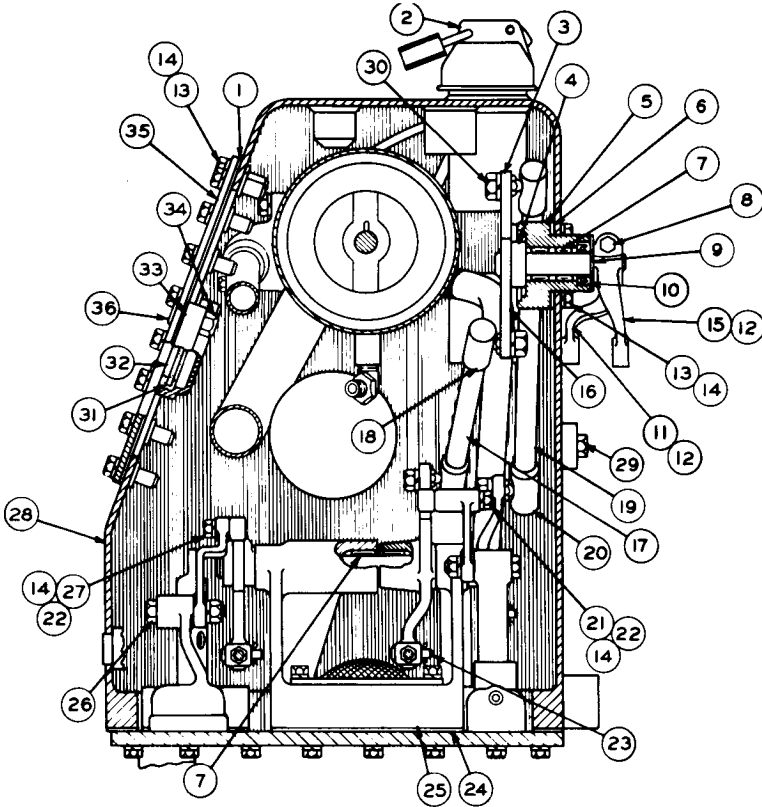

REF. NO.	PART NUMBER	DESCRIPTION	QTY
1	5J5160	GASKET	1
2	5D1910	PROTECTION COVER GROUP (Separate Illustration)	1
3	5J5774	LEVER ASSEM.	1
4	2H5746	ADAPTER	2
5	5J8102	HOUSING	2
6	4J8425	GASKET	2
7	7F7983	BEARING	8
8	S1571	BOLT	2
8	1D4717	NUT	2
9	8B4037	WASHER	2
10	3J4407	SEAL	2
11	7J7557	LEVER	1
12	1B8706	KEY	2
13	S1594	BOLT	52
14	3B4506	LOCKWASHER	54
15	5J5729	LEVER	1
16	5J5776	LEVER ASSEM.	1
17	5J5765	ROD ASSEM.	1
18	2H9250	JOINT	2
19	5J5764	ROD ASSEM.	1
20	2H9250	JOINT	2

21	4J3441	ROLLER	1
22	1B4203	NUT	2
23	5F9199	PIN	2
23	8S7803	RETAINER	2
24	5J5247	GASKET	1
25	7J779	BRACKET	1
25	2J6602	PIN	2
26	1B4204	NUT	2
26	3B4507	LOCKWASHER	2
27	2J8262	ROLLER	1
27	7J774	TANK ASSEM.	1
28	7J775	TANK ASSEM.	1
29	8B910	PLUG	1
29	1B4205	NUT	4
30	3B4508	LOCKWASHER	4
31	4J8252	GLASS	1
32	4J8251	GROMMET	1
33	4J8250	RETAINER	1
34	4J8265	NUT	4
35	6J2459	COVER ASSEM.	1
35	5J5159	COVER	1
36	5J96	STUD	4

119216

6J7041 HYDRAULIC TANK AND VALVE GROUP—Part 3 of 4—Type 1  
 Part of 6K5440 Hydraulic Arrangement listed on Page 150. 5D1910 Cover  
 parts are shown on Page 150. AN ATTACHMENT

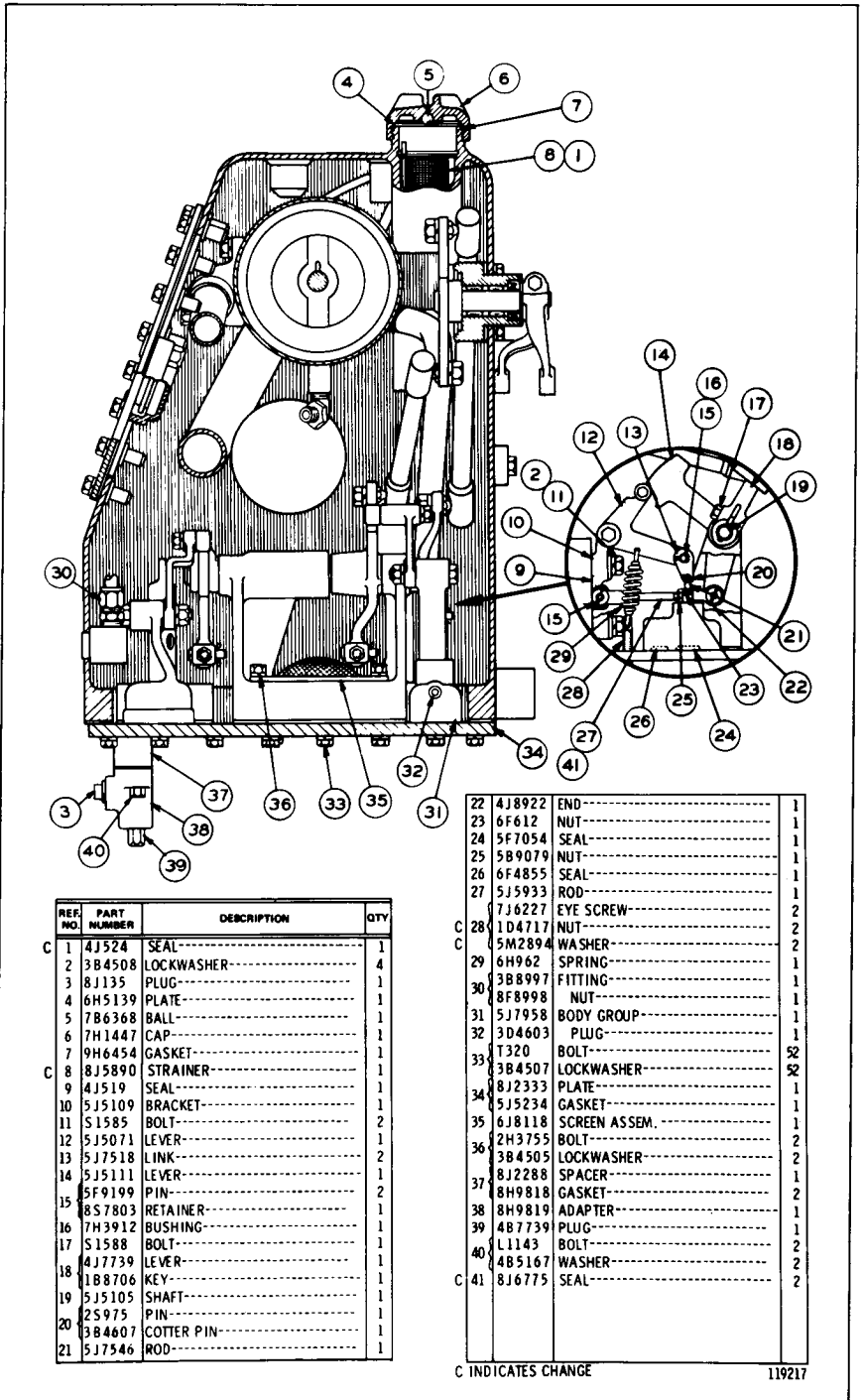

REF. NO.	PART NUMBER	DESCRIPTION	QTY
C 1	4J524	SEAL	1
2	3B4508	LOCKWASHER	4
3	8J135	PLUG	1
4	6H5139	PLATE	1
5	7B6368	BALL	1
6	7H1447	CAP	1
7	9H6454	GASKET	1
8	8J5890	STRAINER	1
C 9	4J519	SEAL	1
10	5J5109	BRACKET	1
11	5J585	BOLT	2
12	5J5071	LEVER	1
13	5J7518	LINK	2
14	5J5111	LEVER	1
15	5F9199	PIN	2
16	8S7803	RETAINER	1
17	7H3912	BUSHING	1
18	5J588	BOLT	1
19	4J7739	LEVER	1
20	1B8706	KEY	1
21	5J5105	SHAFT	1
	2S975	PIN	1
	3B4607	COTTER PIN	1
	5J7546	ROD	1

22	4J8922	END	1
23	6F612	NUT	1
24	5F7054	SEAL	1
25	5B9079	NUT	1
26	6F4855	SEAL	1
27	5J5933	ROD	1
	7J6227	EYE SCREW	2
C 28	1D4717	NUT	2
	5M2894	WASHER	2
29	6H962	SPRING	1
30	3B8997	FITTING	1
	8F8998	NUT	1
31	5J7958	BODY GROUP	1
32	3D4603	PLUG	1
	T320	BOLT	52
33	3B4507	LOCKWASHER	52
	8J2333	PLATE	1
34	5J5234	GASKET	1
35	6J8118	SCREEN ASSEM.	1
	2H3755	BOLT	2
36	3B4505	LOCKWASHER	2
	8J2288	SPACER	1
37	8H9818	GASKET	2
38	8H9819	ADAPTER	1
39	4B7739	PLUG	1
40	L1143	BOLT	2
	4B5167	WASHER	2
C 41	8J6775	SEAL	2

C INDICATES CHANGE

119217

6J7041 HYDRAULIC TANK AND VALVE GROUP—Part 4 of 4—Type 1  
Part of 6K5440 Hydraulic Arrangement listed on Page 150  
AN ATTACHMENT

FIG NO	PART NUMBER	DESCRIPTION	QTY
1	1165	BOLT	2
2	384506	LOCKWASHER	6
3	515937	TUBE ASSEM.	1

4	612363	TUBE—(.25" O. D.)	1
5	535146	BRACKET	2
6	641717	BOLT	2
7	384508	LOCKWASHER	12
8	484280	WASHER	2
9	612362	TUBE—(.25" O. D.)	1
10	51585	BOLT	2
11	388995	FITTING	2
12	1F1344	NUT	1

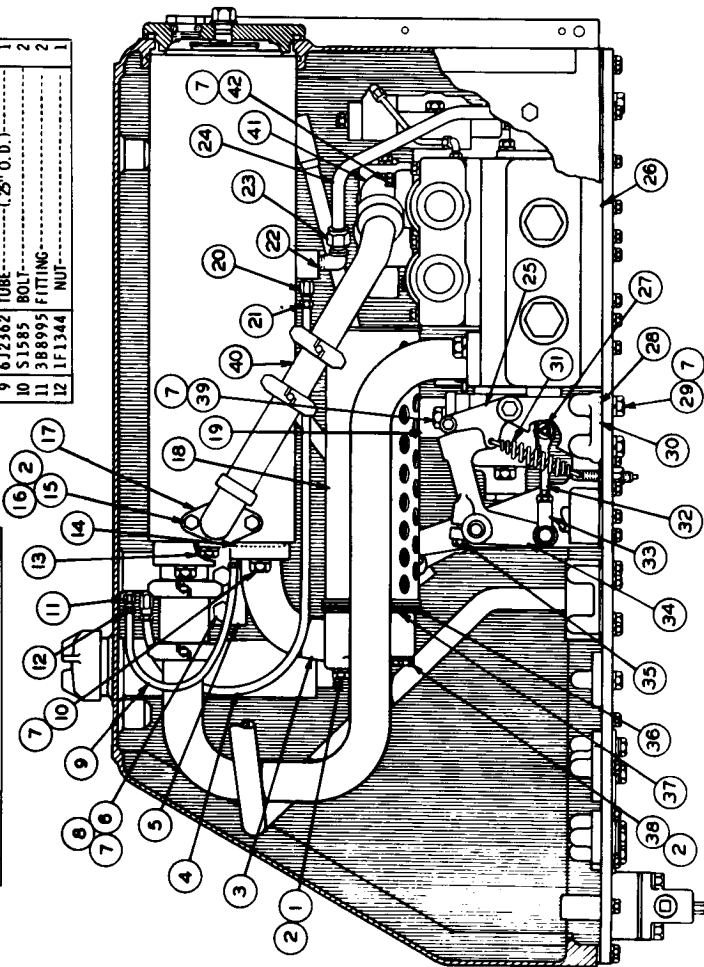

13	T318	BOLT	2
14	384507	LOCKWASHER	2
15	484279	WASHER	1
16	7F8267	SEAL	1
17	2H5330	BOLT—(2.875" Long)	1
18	381915	BOLT—(1.375" Long)	1
19	713572	TUBE ASSEM.	1
20	3D9412	GASKET	1
21	71773	TUBE ASSEM.	1
22	516022	TUBE	2
23	388996	FITTING	2
24	8F8997	NUT	1
25	389053	FITTING	1
26	8F8998	NUT	1
27	71748	TUBE	1
28	515108	LEVER	1
29	517953	CONTROL VALVE GROUP— (Separate Illustration)	1
30	5F9199	PIN	1
31	857803	RETAINER	1
32	8F3469	SEAL	4
33	783235	BOLT	2
34	7J6226	BRACKET	1
35	8H962	SPRING	1
36	515932	ROD	1
37	4J8922	END	1
38	589079	NUT	1
39	515110	LEVER	1
40	188706	KEY	1
41	1A2209	BOLT	1
42	519261	DISC	1
43	515942	GASKET	2
44	51619	BOLT	2
45	51595	BOLT	2
46	758062	JOINT	1
47	713570	TUBE ASSEM.	1
48	713573	GASKET	1
49	282006	BOLT	2

119214

6J7041 HYDRAULIC TANK AND VALVE GROUP—Part 1 of 4—Type 2  
 Part of 6K5440 Hydraulic Arrangement listed on Page 150. 5J7953 Valve parts are shown on Pages 174 and 175.  
 Only separate parts serviced. When complete Group is required, order 9J641 shown on Pages 167E through 167H  
 AN ATTACHMENT



6J7041 HYDRAULIC TANK AND VALVE GROUP—Part 2 of 4—Type 2  
 Part of 6K5440 Hydraulic Arrangement listed on Page 150. Only separate parts serviced  
 When complete Group is required, order 9J641 shown on Pages 167E through 167H. AN ATTACHMENT

REF. NO.	PART NUMBER	DESCRIPTION	QTY.
1	1515182	TUBE ASSEM.	1
2	257070	JOINT ASSEM.	1
3	932082	SEAL ASSEM.	2
4	6L2849	COUPLING ASSEM.	1
5	2N8198	SEAL ASSEM.	2
6	51587	BOLT	2
7	3184508	LOCKWASHER	12
8	515157	TUBE ASSEM.	1

7	5F8000	SEAL	1
8	716096	TUBE ASSEM.	1
9	416064	ELEMENT ASSEM.	1
10	613795	SCREEN ASSEM.	1
11	21917	RETAINER	1
12	1H1200	PIN—(1.25" Long)	1
13	7J5925	PIN—(1.25" Long)	1

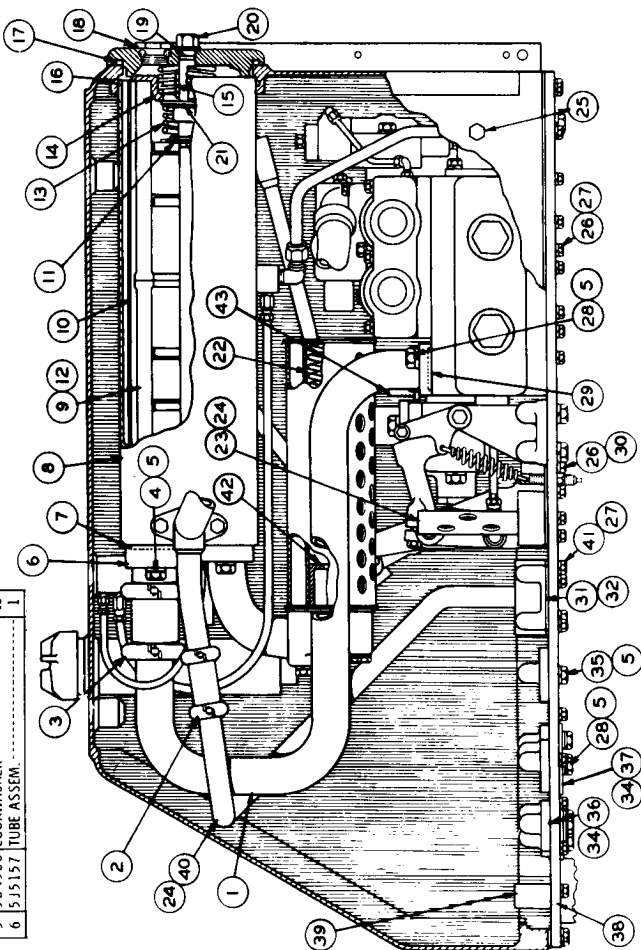

12	617096	ELEMENT ASSEM.	1
13	512926	SPRING—(Steel)	1
14	411704	SEAT	1
15	612236	SPRING	1
16	2K4472	SEAL	1
17	719197	COVER	1
18	958010	PLUG	2
19	254078	SEAL	2
20	6F4855	SEAL	1
21	21918	VALVE	1
22	613911	SPRING	1
23	71772	TUBE ASSEM.	1
24	5J5166	GASKET	2
25	954182	PLUG	1
26	1A2029	BOLT	11
27	384506	LOCKWASHER	16
28	51585	BOLT	10
29	1H9696	SEAL	1
30	4B5167	WASHER	3
31	712852	COVER	2
32	418425	GASKET	2
33	211799	GASKET	9
34	7B3235	BOLT	3
35	816129	COVER	4
36	1J8476	COVER	5
37	3F4479	PIN	2
38	823381	BLOCK	2
39	823352	GASKET	2
40	5J5202	TUBE ASSEM.	1
41	51588	BOLT	8
42	6J3908	ORIFICE	1
43	614578	STOP	1

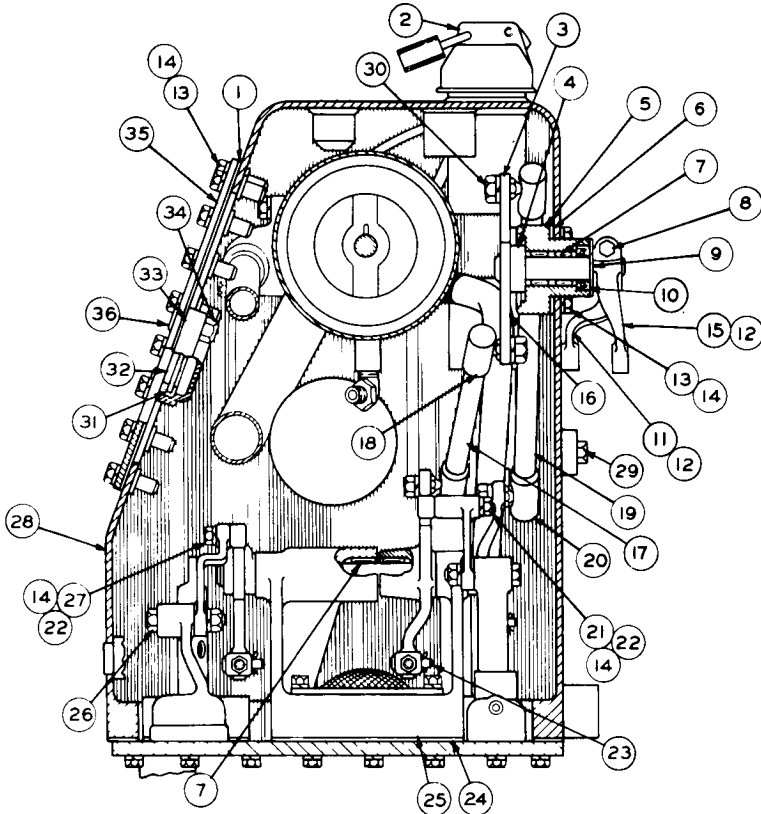

REF. NO.	PART NUMBER	DESCRIPTION	QTY
1	5J5160	GASKET	1
2	5D1910	PROTECTION COVER GROUP (Separate Illustration)	1
3	5J5774	LEVER ASSEM.	1
4	2H5746	ADAPTER	2
5	5J8102	HOUSING	2
6	4J8425	GASKET	2
7	7F7983	BEARING	8
8	S1571	BOLT	2
9	1D4717	NUT	2
10	8B4037	WASHER	2
11	3J4407	SEAL	2
12	7J7557	LEVER	1
13	1B8706	KEY	2
14	S1594	BOLT	52
15	3B4506	LOCKWASHER	54
16	5J5729	LEVER	1
17	5J5776	LEVER ASSEM.	1
18	5J5765	ROD ASSEM.	1
19	2H9250	JOINT	2
20	5J5764	ROD ASSEM.	1
	2H9250	JOINT	2

21	4J3441	ROLLER	1
22	1B4203	NUT	2
23	5F9199	PIN	2
	8S7803	RETAINER	2
24	5J5247	GASKET	1
25	7J779	BRACKET	1
	2J6602	PIN	2
26	1B4204	NUT	2
	3B4507	LOCKWASHER	2
27	2J8262	ROLLER	1
28	7J774	TANK ASSEM.	1
	7J775	TANK ASSEM.	1
29	8B910	PLUG	1
	1B4205	NUT	4
30	3B4508	LOCKWASHER	4
31	4J8252	GLASS	1
32	4J8251	GROMMET	1
33	4J8250	RETAINER	1
34	4J8265	NUT	4
35	6J2459	COVER ASSEM.	1
	5J5159	COVER	1
36	5J96	STUD	4

119216

6J7041 HYDRAULIC TANK AND VALVE GROUP—Part 3 of 4—Type 2  
 Part of 6K5440 Hydraulic Arrangement listed on Page 150. 5D1910 Cover parts  
 are shown on Page 150. Only separate parts serviced. When complete Group is  
 required, order 9J641 shown on Pages 167E through 167H. Note: 6J468  
 Indicator Assembly is available. AN ATTACHMENT

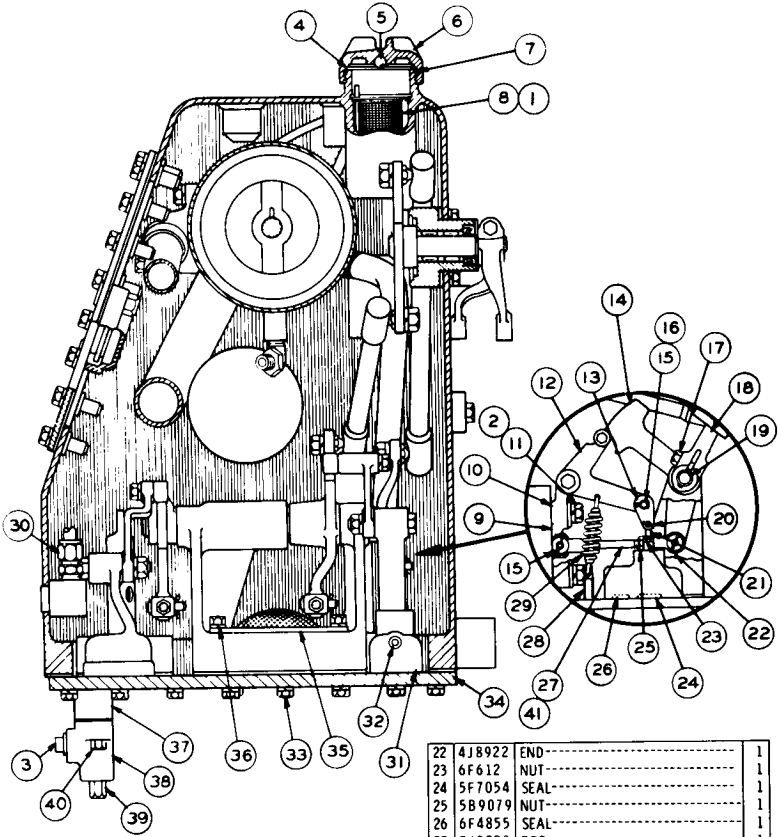

REF NO.	PART NUMBER	DESCRIPTION	QTY
C 1	5K216	SEAL	1
2	3B4508	LOCKWASHER	4
3	8J135	PLUG	1
4	6H5139	PLATE	1
5	7B6368	BALL	1
6	7H1447	CAP	1
7	9H6454	GASKET	1
C 8	9J3050	STRAINER	1
9	4J519	SEAL	1
10	5J5109	BRACKET	1
11	5I585	BOLT	2
12	5J5071	LEVER	1
13	5J7518	LINK	2
14	5J5111	LEVER	1
15	5F9199	PIN	2
16	8S7803	RETAINER	1
17	7H3912	BUSHING	1
18	5I588	BOLT	1
19	4J7739	LEVER	1
20	1B8706	KEY	1
21	5J5105	SHAFT	1
	2S975	PIN	1
	3B4607	COTTER PIN	1
	5J7546	ROD	1

22	4J8922	END	1
23	6F612	NUT	1
24	5F7054	SEAL	1
25	5B9079	NUT	1
26	6F4855	SEAL	1
27	5J5933	ROD	1
	7J6227	EYE SCREW	2
28	104717	NUT	2
	5M2894	WASHER	2
29	6H962	SPRING	1
30	3B8997	FITTING	1
	8F8998	NUT	1
31	5J7958	BODY GROUP	1
32	304603	PLUG	1
	T320	BOLT	52
33	3B4507	LOCKWASHER	52
	8J2333	PLATE	1
34	5J5234	GASKET	1
	6J8118	SCREEN ASSEM.	1
	2H3755	BOLT	2
36	3B4505	LOCKWASHER	2
	8J2288	SPACER	1
37	8H9818	GASKET	2
	8H9819	ADAPTER	1
39	4B7739	PLUG	1
40	L1143	BOLT	2
	4B5167	WASHER	2
41	8J6775	SEAL	2

C INDICATES CHANGE

148055

6J7041 HYDRAULIC TANK AND VALVE GROUP—Part 4 of 4—Type 2  
 Part of 6K5440 Hydraulic Arrangement listed on Page 150. Only separate parts serviced. When complete Group is required, order 9J641 shown on Pages 167E through 167H. AN ATTACHMENT

REQ. NO.	PART NUMBER	DESCRIPTION	QTY.
1	6J2363	TUBE	1
2	5J5146	BRACKET	1
3	6H1717	BOLT	2
4	4B4280	WASHER	2

4	3B4508	LOCKWASHER	16
5	6J2362	TUBE	1
6	3B8995	FITTING	2
7	1F1344	NUT	1

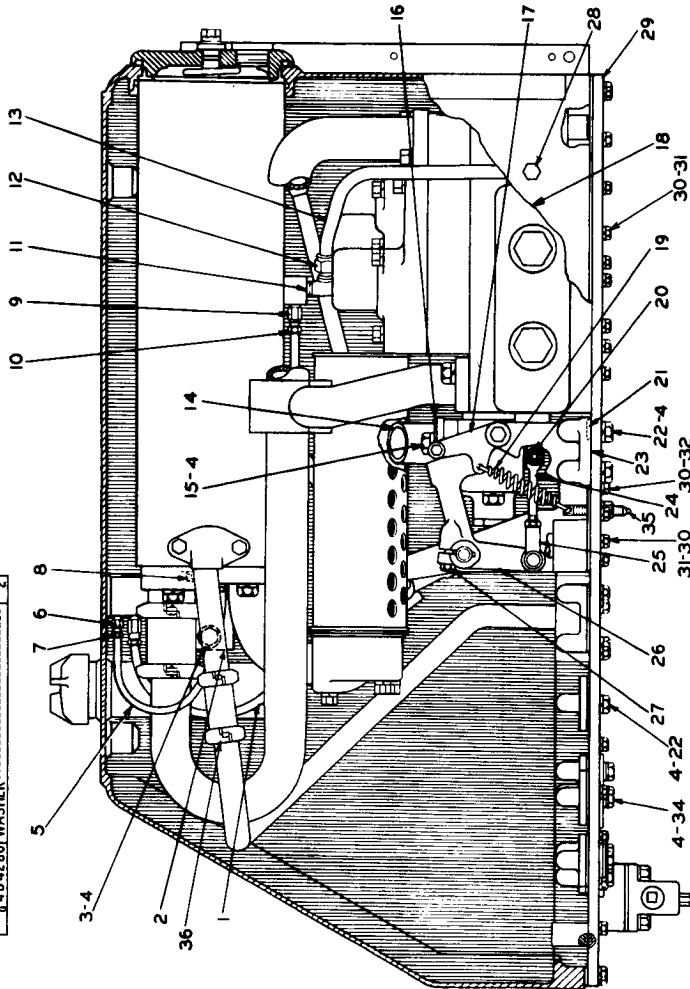

1	1318	BOLT	2
8	3B4507	LOCKWASHER	2
9	4B4279	WASHER	2
10	3B8996	FITTING	2
11	8F6997	NUT	1
12	3B9053	FITTING	1
13	8F6998	NUT	1
14	7J748	TUBE	1
15	3B8997	FITTING	1
16	8F6998	NUT	1
17	5J6022	TUBE ASSEM.	1
18	5L595	BOLT	2
19	6J4578	STOP	1
20	5J5108	LEVER	1
21	9J643	CONTROL VALVE GROUP (Separate Illustration)	1
22	6H962	SPRING	1
23	85F9189	PIN	1
24	857803	RETAINER	1
25	18F3469	SEAL	4
26	7B3235	BOLT	2
27	7J6226	BRACKET	1
28	5J5932	ROD	1
29	4J8922	END	1
30	5B9079	NUT	1
31	5L5110	LEVER	1
32	188706	KEY	1
33	1A2209	BOLT	1
34	9J54182	PLUG	1
35	3J7354	SEAL	1
36	8J2333	PLATE	1
37	5J5234	GASKET	1
38	1A2029	ROD	11
39	3B4506	LOCKWASHER	8
40	4B5167	WASHER	3
41	5L587	BOLT	8
42	7J6227	EYESCREW	2
43	104717	NUT	2
44	5M2894	WASHER	2
45	8J6775	SEAL	2
46	2J57070	JOINT ASSEM.	1

149714

9J641 HYDRAULIC TANK AND VALVE GROUP—Part 1 of 4  
 Part of 6K5440 Hydraulic Arrangement listed on Page 150  
 9J643 Valve parts are shown on Pages 176A and 176B. AN ATTACHMENT

9J641 HYDRAULIC TANK AND VALVE GROUP—Part 2 of 4  
 Part of 6K5440 Hydraulic Arrangement listed on Page 150  
 AN ATTACHMENT

REF. NO.	PART NUMBER	DESCRIPTION	QTY
1	9 J5202	TUBE ASSEM.	1
2	6 L2849	Coupling ASSEM.	1
2	2 N8198	SEAL ASSEM.	2
3	S 1595	BOLT	2
4	384508	LOCKWASHER	6
5	9 J4028	TUBE	1

6	5F8000	SEAL	1
7	7 J6096	TUBE ASSEM.	1
8	4 J6064	ELEMENT ASSEM. (paper)	1
8	6 J7096	ELEMENT ASSEM. (steel)	1
9	6 J3795	SCREEN ASSEM.	1
10	1 H1200	PIN—3.18 cm (1.25 in.) long	1
10	7 J5925	PIN—2.86 cm (1.125 in.) long	1
11	2 J917	RETAINER	1

12	7 J5586	BOLT	1
13	5 J2926	SPRING	1
14	2 J918	VALVE	1
15	4 J1704	SEAT	1
16	6 J2236	SPRING	1
17	7 J9197	COVER	1
17	5 L5032	SEAL	1
18	9 S8010	PLUG	1
18	2 S4078	SEAL	1
19	6 F4855	SEAL	1
20	S 1588	BOLT	1
21	2 K4472	SEAL	8
22	5 S185	BOLT	1
23	1 H9696	SEAL	6
24	7 J2852	COVER	2
25	4 J8425	GASKET	2
26	8 J6129	COVER	2
27	7 J772	TUBE ASSEM.	1
28	5 J5166	GASKET	1
29	5 J9261	DISC	1
30	S 1619	BOLT	2
31	384506	LOCKWASHER	14
32	8 J2381	BLOCK	2
33	8 J2352	GASKET	2
33	T 65	BOLT	2
34	5 J5937	TUBE ASSEM.	1
34	5 J5942	GASKET	2
36	5 J5182	TUBE ASSEM.	1
37	3 F4479	PIN	2
38	7 F8267	SEAL	1
39	309412	GASKET	1
40	6 J236	TUBE ASSEM.	1
41	6 J3908	ORIFICE	1
42	6 J3911	SPRING	1
43	7 J773	TUBE ASSEM.	1
44	1 J8476	COVER	4
44	2 J1799	GASKET	4

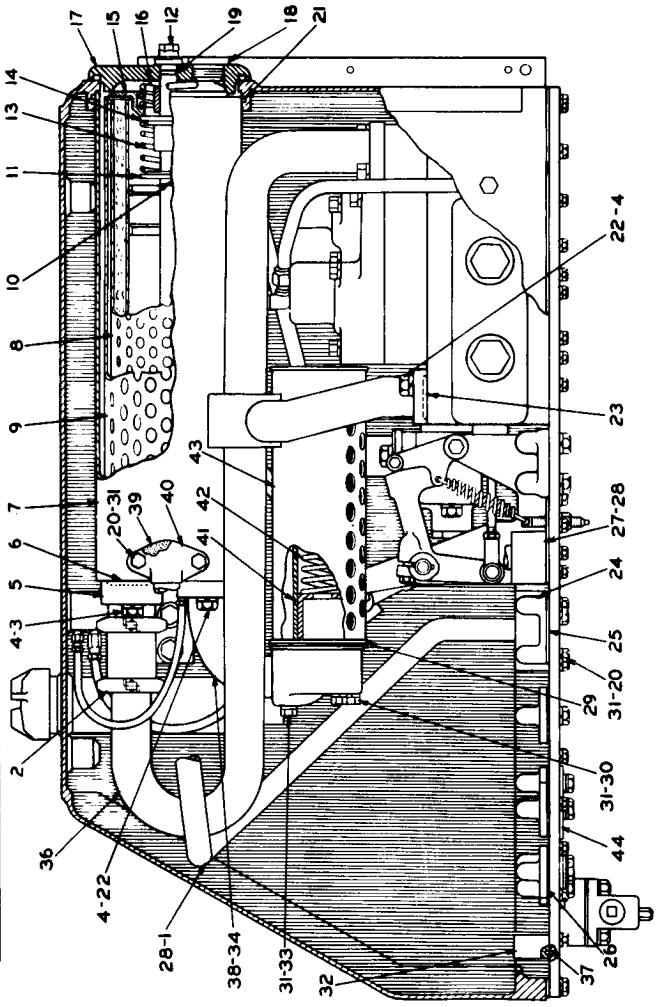

148915

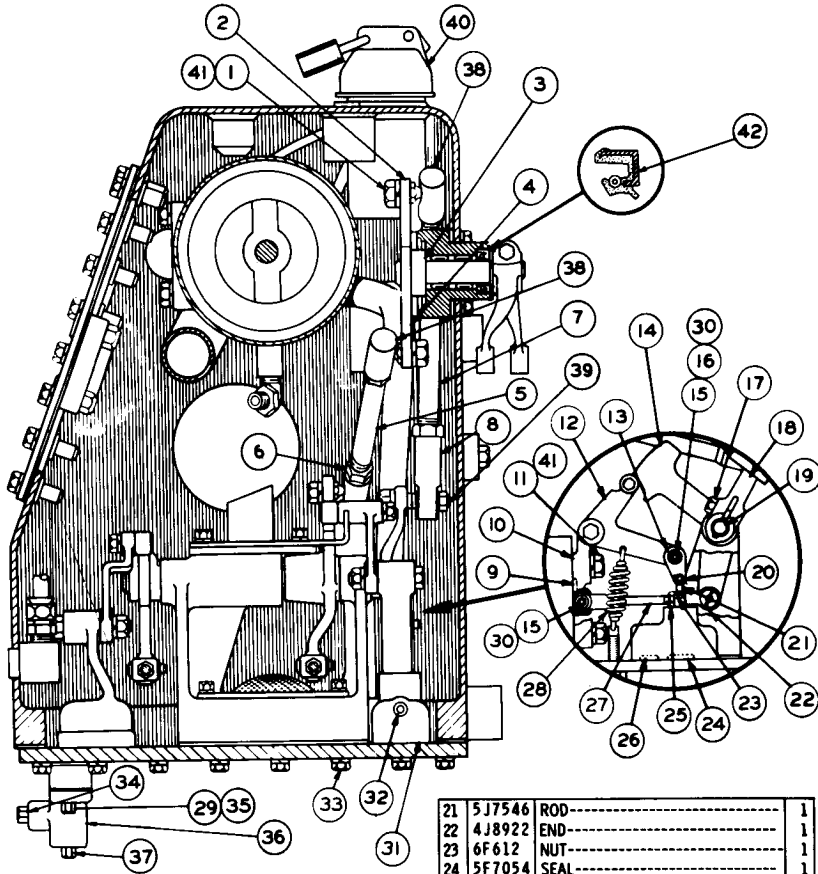

REF. NO.	PART NUMBER	DESCRIPTION	QTY
1	1B4205	NUT-----	3
2	9J652	LEVER ASSEM.-----	1
3	2H5746	ADAPTER-----	2
4	8J6135	LEVER ASSEM.-----	1
5	8J6101	ROD-----	1
6	1B4430	NUT-----	4
7	5J7702	ROD-----	1
8	4D4065	ROD END-----	4
9	4J519	SEAL-----	1
10	5J5109	BRACKET-----	1
11	S1585	BOLT-----	2
12	5J5071	LEVER-----	1
13	5J7518	LINK-----	2
14	5J5111	LEVER-----	1
15	5F9199	PIN-----	2
16	7H3912	BUSHING-----	1
17	S1588	BOLT-----	1
18	4J7739	LEVER-----	1
18	1B8706	KEY-----	1
19	9J653	SHAFT-----	1
20	2S975	PIN-----	1
20	3B4607	COTTER PIN-----	1

21	5J7546	ROD-----	1
22	4J8922	END-----	1
23	6F612	NUT-----	1
24	5F7054	SEAL-----	1
25	5B9079	NUT-----	1
26	6F4855	SEAL-----	1
27	5J5933	ROD-----	1
28	6H962	SPRING-----	1
29	L1143	BOLT-----	2
30	8S7803	RETAINER-----	2
31	5J7958	BODY GROUP-----	1
32	3D4603	PLUG-----	1
33	T320	BOLT-----	52
33	3B4507	LOCKWASHER-----	52
34	8J135	PLUG-----	1
35	4B5167	WASHER-----	2
36	8H9819	ADAPTER-----	1
36	8H9818	GASKET-----	2
36	8J2288	SPACER-----	1
37	4B7739	PLUG-----	1
38	8J6171	ROD END ASSEM.-----	3
39	S1587	BOLT-----	1
39	1K6872	NUT-----	1
40	5D1910	COVER GROUP-----	1
(Separate Illustration)			
41	3B4508	LOCKWASHER-----	5
42	3J4407	SEAL-----	2

148916

9J641 TANK AND VALVE GROUP—Part 3 of 4  
 Part of 6K5440 Hydraulic Arrangement listed on Page 150. 5D1910 Cover parts are shown on Page 150. Note: 6J468 Indicator Assembly is available  
 AN ATTACHMENT

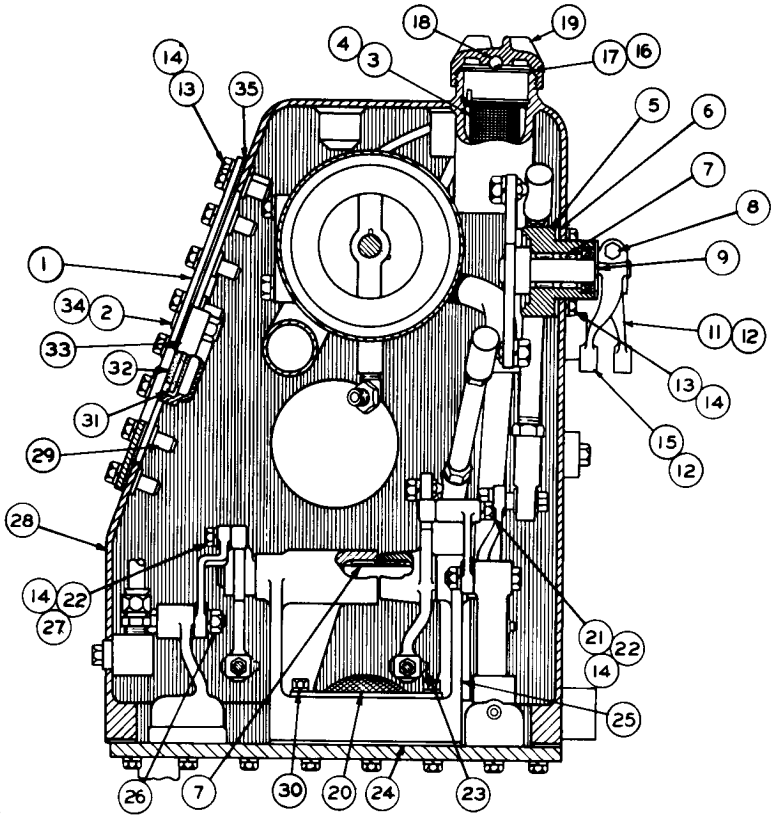

REF. NO.	PART NUMBER	DESCRIPTION	QTY
1	9J654	COVER ASSEM	1
2	8J6910	STUD	4
3	9J3047	STRAINER	1
4	5K216	SEAL	1
5	5J8102	HOUSING	2
6	4J8425	GASKET	2
7	9H8751	BEARING	8
8	51571	BOLT	2
8	1D4717	NUT	2
9	8B4037	WASHER	2
11	7J7557	LEVER	1
12	1B8706	KEY	2
13	51594	BOLT	52
14	3B4506	LOCKWASHER	54
15	5J5729	LEVER	1
16	9H6454	GASKET	1
17	6H5139	PLATE	1
18	7B6368	BALL	1
19	7H1447	CAP	1
20	6J8118	SCREEN ASSEM	1
21	4J3441	ROLLER	1
22	1B4203	NUT	2

23	5F9199	PIN	2
	8S7803	RETAINER	2
24	5J5247	GASKET	1
25	7J779	BRACKET	1
	2J6602	PIN	2
26	1B4204	NUT	2
	3B4507	LOCKWASHER	2
27	2J8262	ROLLER	1
28	9J647	TANK ASSEM	1
	6J2333	BOSS	1
29	6J2237	BOSS	44
	2H3755	BOLT	2
30	3B4505	LOCKWASHER	2
31	4J8252	GLASS	1
32	4J8251	GROMMET	1
33	8J6913	RETAINER	1
34	4J8265	NUT	4
35	5J5160	GASKET	1

148917

9J641 TANK AND VALVE GROUP—Part 4 of 4  
 Part of 6K5440 Hydraulic Arrangement listed on Page 150  
 AN ATTACHMENT

3	5J5937	TUBE ASSEM.	1
4	6J2363	TUBE	1
5	5J5146	BRACKET	1
6	6H1717	BOLT	2
7	3B4508	LOCKWASHER	10
8	4B4280	WASHER	2
9	6J2362	TUBE	1
10	5L1585	BOLT	2

REF. NO.	PART NUMBER	DESCRIPTION	QTY.
1	1T65	BOLT	2
2	13B4506	LOCKWASHER	6

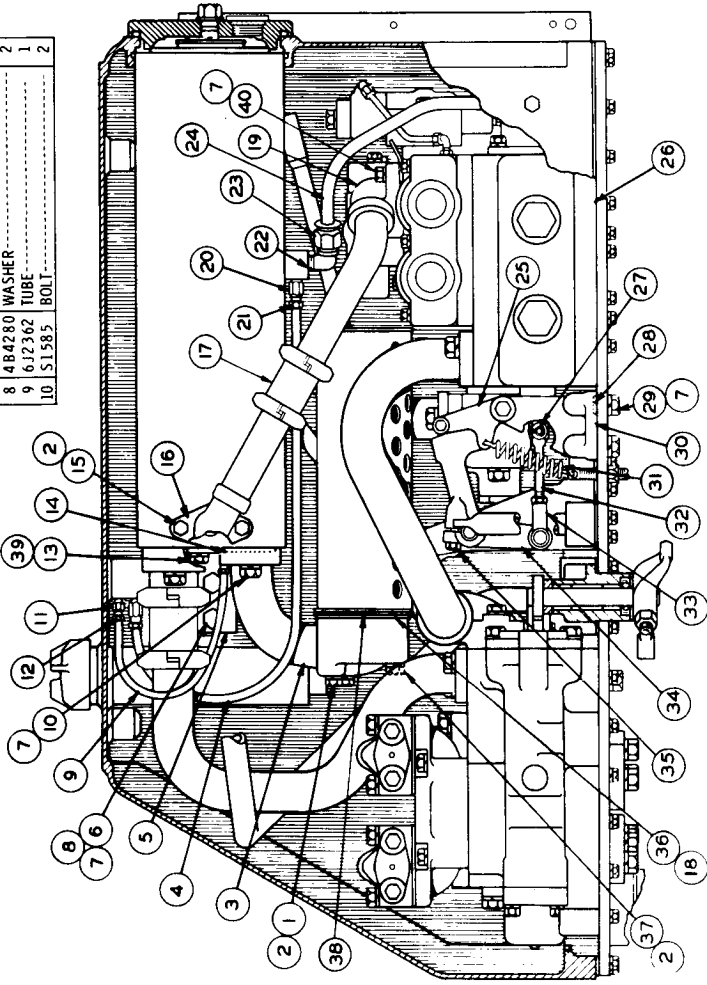

11	3B8995	FITTING	2
12	1F1344	NUT	1
13	1T318	BOLT	2
13A	3B4507	LOCKWASHER	2
14	7F8267	SEAL	1
15	3B1915	BOLT	1
15A	2H5330	BOLT	1
15B	2H5330	BOLT	1
16	7J3572	TUBE ASSEM.	1
16A	3D9412	GASKET	1
17	7S8062	JOINT	1
18	5J9261	DISC	1
19	7J3570	TUBE ASSEM.	1
19A	7J3573	GASKET	1
20	3B8996	FITTING	2
21	8F8907	NUT	1
22	3B9053	FITTING	1
23	8F8998	NUT	1
24	7J748	TUBE	1
25	5J5108	LEVER	1
26	5J7953	CONTROL VALVE GROUP	1
		(Separate Illustration)	
27	5F9109	PIN	1
27A	18S7803	RETAINER	1
28	8F3469	SEAL	1
29	7B3235	BOLT	4
30	7J6226	BRACKET	6
31	6H962	SPRING	1
32	5J5932	ROD	1
33	1J8489	END	1
33A	3B9079	NUT	1
34	5J5110	LEVER	1
35	1B8706	KEY	1
35A	1A2209	BOLT	1
36	5J5942	GASKET	1
37	5J1619	BOLT	2
38	5J5942	GASKET	1
39	4B4279	WASHER	2
40	2B2006	BOLT	2

C INDICATES CHANGE

119223

5J5726 HYDRAULIC TANK AND VALVE GROUP—Part 1 of 5—Type 1  
 Part of 5K6273 and 2P8032 Hydraulic Arrangements listed on Page 148  
 5J7953 Valve parts are shown on Pages 174 through 175B. AN ATTACHMENT



5J5726 HYDRAULIC TANK AND VALVE GROUP—Part 2 of 5—Type 1  
Part of 5K6273 and 2P8032 Hydraulic Arrangement listed on Page 148  
AN ATTACHMENT

REF. NO.	PART NUMBER	DESCRIPTION	QTY
1	5J5179	TUBE ASSEM.	1
2	6L2849	COUPLING ASSEM.	1
2	2N8198	SEAL ASSEM.	2

3	1A1460	BOLT	8
4	51587	BOLT	2
5	384508	LOCKWASHER	12
6	51595	BOLT	2

7	5F8000	SEAL	1
8	716096	TUBE ASSEM.	1
9	515202	TUBE ASSEM.	1
10	5J5166	GASKET	2
11	257070	JOINT ASSEM.	2
12	952082	SEAL ASSEM.	1
13	5J5157	TUBE ASSEM.	1
14	4J6064	ELEMENT ASSEM.	2
15	6J3795	SCREEN ASSEM.	1
16	21918	VALVE	1
17	4J11704	SEAT	1
18	6J2236	SPRING	1
19	719197	COVER	1
20	5L5032	SEAL	1
21	958010	PLUG	1
22	254078	SEAL	1
23	6F4855	SEAL	1
24	715986	BOLT	1
25	1H1200	PIN	1
26	715925	COTTER PIN	1
27	2K4472	SEAL	1
28	516022	TUBE	1
29	21917	RETAINER	1
30	95A182	PLUG	1
31	37354	SEAL	1
32	1A2029	BOLT	11
33	384506	LOCKWASHER	3
34	485167	WASHER	3
35	3K2759	COVER	4
36	4J523	SEAL	4
37	512926	SPRING	4
38	6J3911	SPRING	1
39	71773	TUBE ASSEM.	1
40	6J3908	ORIFICE	1
41	71772	TUBE ASSEM.	1
42	8J2381	BLOCK	2
43	8J2352	GASKET	2
44	3E4479	PIN	2

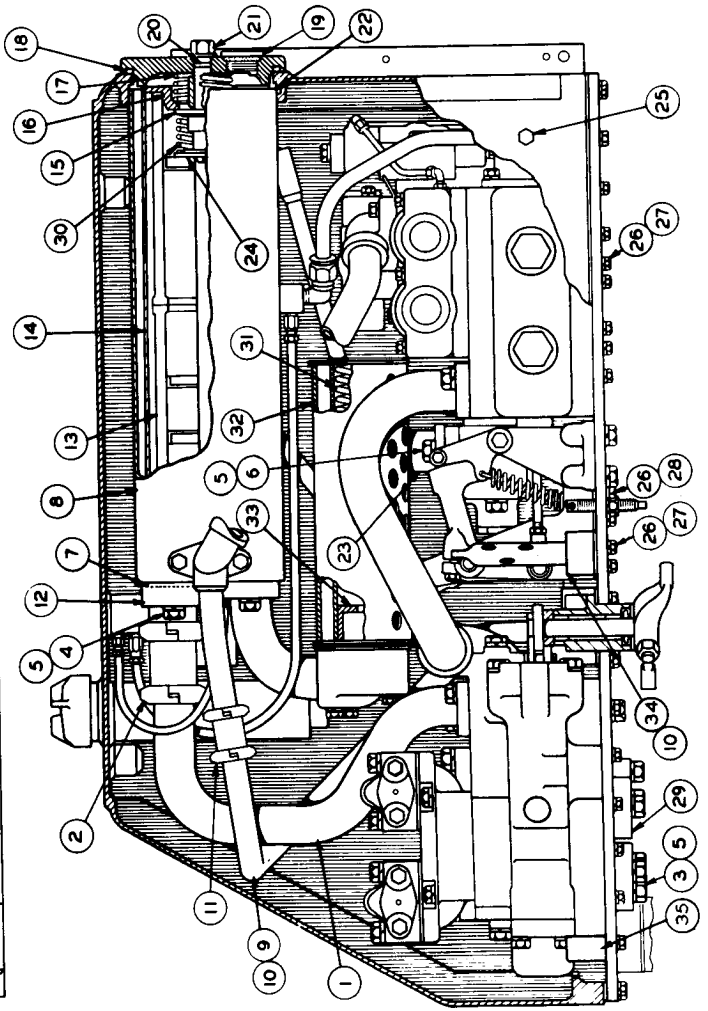

119224

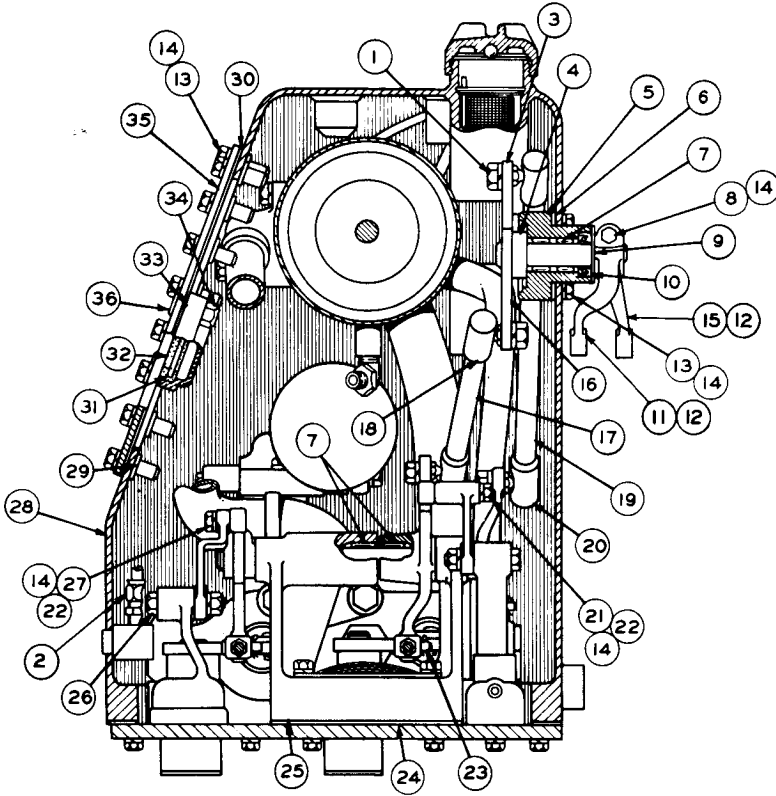

REF. NO.	PART NUMBER	DESCRIPTION	QTY
1	1B4205	NUT-----	4
	3B4508	LOCKWASHER-----	4
	3B8997	FITTING-----	1
	8F8998	NUT-----	1
3	5J5774	LEVER ASSEM.-----	1
4	2H5746	ADAPTER-----	2
5	5J8102	HOUSING-----	2
6	4J8425	GASKET-----	2
7	7F7983	BEARING-----	8
8	51571	BOLT-----	2
	1D4717	NUT-----	2
9	8B4037	WASHER-----	2
10	3J4407	SEAL-----	2
11	7J7557	LEVER-----	1
12	1B8706	KEY-----	2
13	51594	BOLT-----	52
14	3B4506	LOCKWASHER-----	56
15	5J5729	LEVER-----	1
16	5J5776	LEVER ASSEM.-----	1
17	5J5765	ROD ASSEM.-----	1
18	2H9250	JOINT-----	2

19	5J5764	ROD ASSEM.-----	1
20	2H9250	JOINT-----	2
21	4J3441	ROLLER-----	1
22	1B4203	NUT-----	2
23	5F9199	PIN-----	2
	8S7803	RETAINER-----	2
24	5J5247	GASKET-----	1
25	7J779	BRACKET-----	1
	2I6602	PIN-----	2
26	1B4204	NUT-----	2
	3B4507	LOCKWASHER-----	2
27	2J8262	ROLLER-----	1
28	7J775	TANK ASSEM.-----	1
29	6J2237	BOSS-----	44
30	5J5160	GASKET-----	1
31	4J8252	GLASS-----	1
32	4J8251	GROMMET-----	1
33	4J8250	RETAINER-----	1
34	4J8265	NUT-----	4
	6J2459	COVER ASSEM.-----	1
35			
	5J5159	COVER-----	1
36	5196	STUD-----	4

119225

5J526 HYDRAULIC TANK AND VALVE GROUP—Part 3 of 5—Type 1  
Part of 5K6273 and 2P8032 Hydraulic Arrangements listed on Page 148  
AN ATTACHMENT

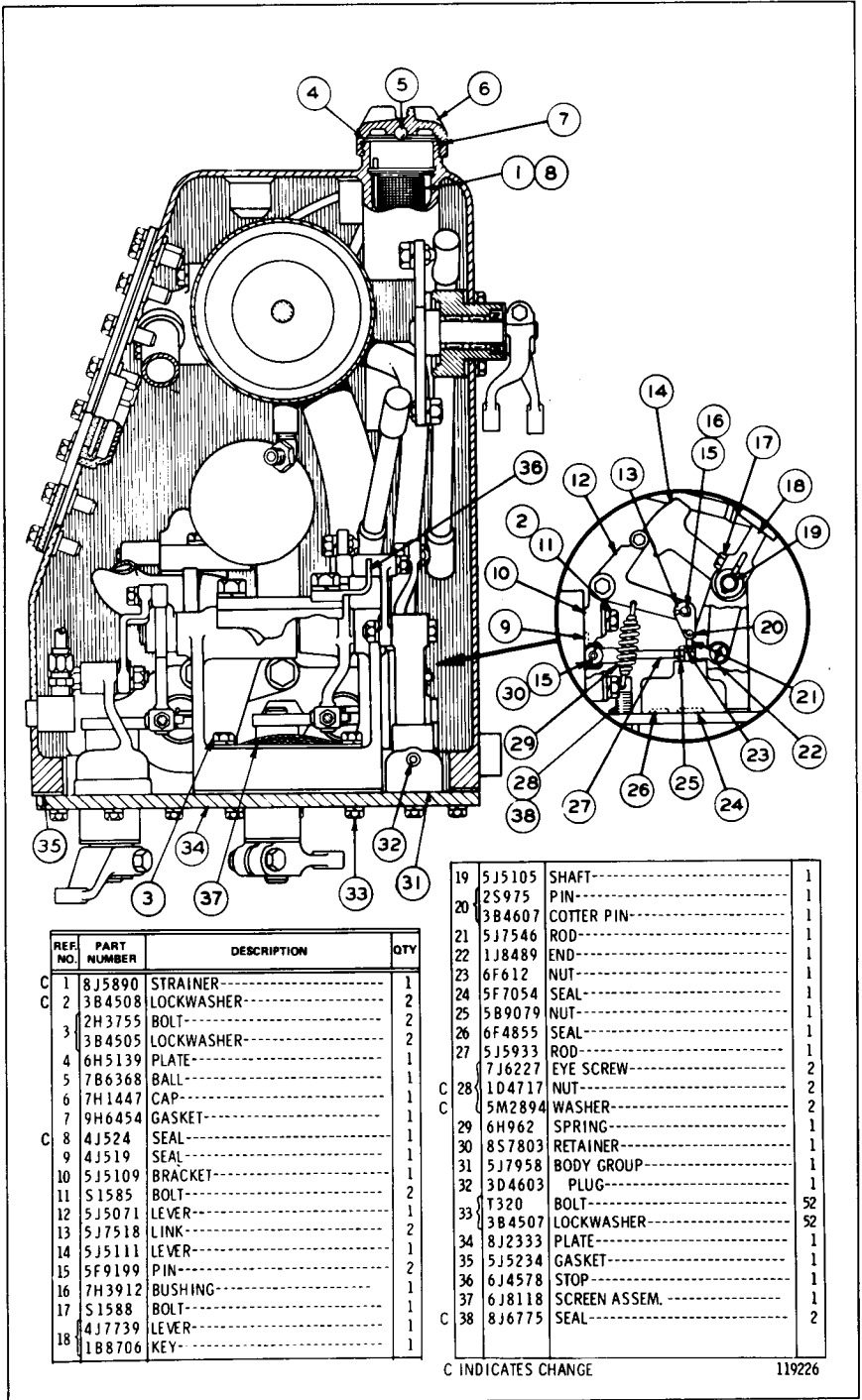

REF. NO.	PART NUMBER	DESCRIPTION	QTY
1	8J5890	STRAINER-----	1
C 2	3B4508	LOCKWASHER-----	2
3	2H3755	BOLT-----	2
3	3B4505	LOCKWASHER-----	2
4	6H5139	PLATE-----	1
5	7B6368	BALL-----	1
6	7H1447	CAP-----	1
7	9H6454	GASKET-----	1
C 8	4J524	SEAL-----	1
9	4J519	SEAL-----	1
10	5J5109	BRACKET-----	1
11	S1585	BOLT-----	2
12	5J5071	LEVER-----	1
13	5J7518	LINK-----	2
14	5J5111	LEVER-----	1
15	5F9199	PIN-----	2
16	7H3912	BUSHING-----	1
17	S1588	BOLT-----	1
18	4J7739	LEVER-----	1
	1B88706	KEY-----	1

19	5J5105	SHAFT-----	1
20	2S975	PIN-----	1
	3B4607	COTTER PIN-----	1
21	5J7546	ROD-----	1
22	1J8489	END-----	1
23	6F612	NUT-----	1
24	5F7054	SEAL-----	1
25	5B9079	NUT-----	1
26	6F4855	SEAL-----	1
27	5J5933	ROD-----	1
	7J6227	EYE SCREW-----	2
C 28	1O4717	NUT-----	2
C	5M2894	WASHER-----	2
29	6H962	SPRING-----	1
30	8S7803	RETAINER-----	1
31	5J7958	BODY GROUP-----	1
32	3D4603	PLUG-----	1
33	T320	BOLT-----	52
	3B4507	LOCKWASHER-----	52
34	8J2333	PLATE-----	1
35	5J5234	GASKET-----	1
36	6J4578	STOP-----	1
37	6J8118	SCREEN ASSEM.-----	1
C 38	8J6775	SEAL-----	2

C INDICATES CHANGE

119226

5J5726 HYDRAULIC TANK AND VALVE GROUP—Part 4 of 5—Type 1  
 Part of 5K6273 and 2P8032 Hydraulic Arrangements listed on Page 148  
 AN ATTACHMENT

CATERPILLAR 977L TRAXCAVATOR

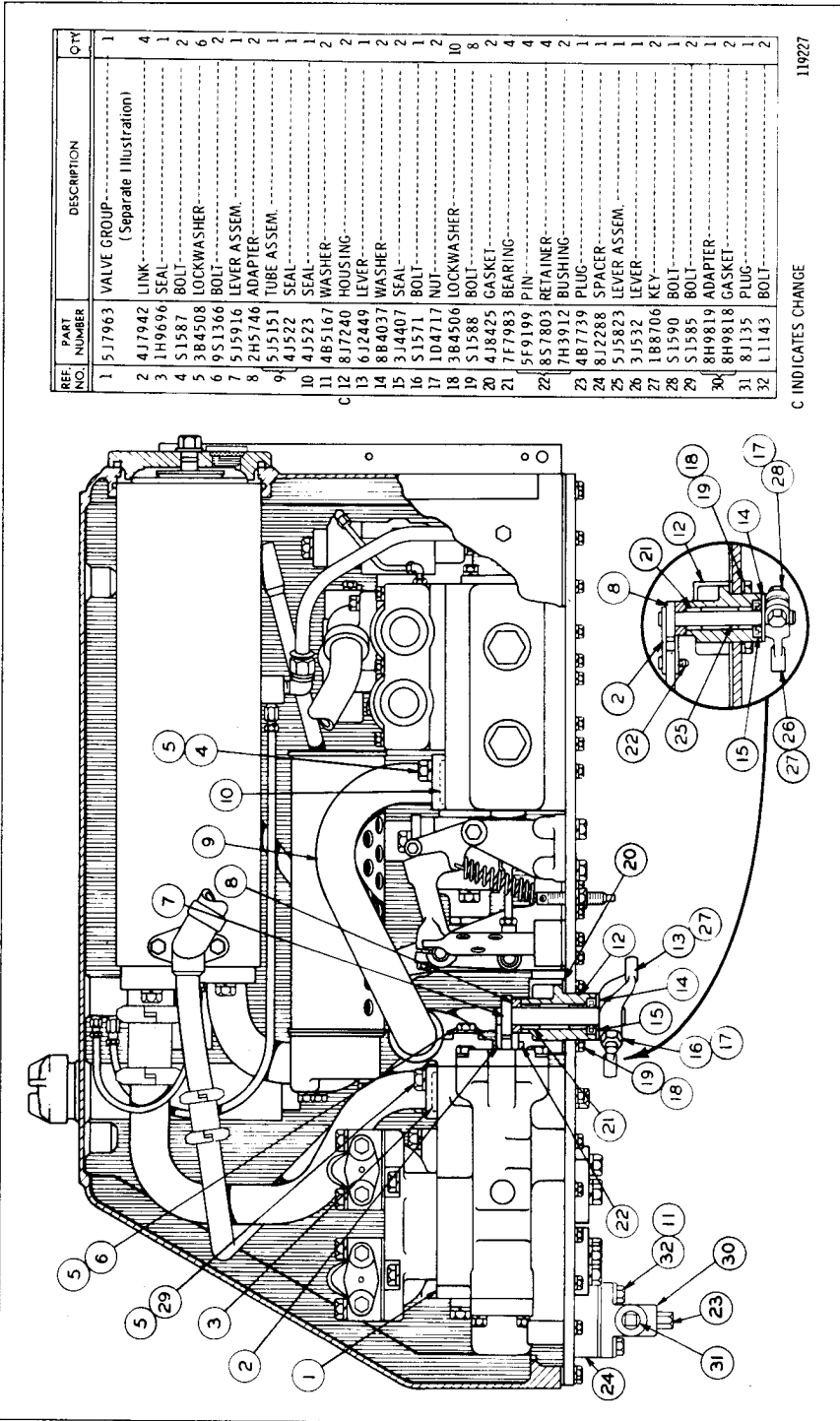

REF. NO.	PART NUMBER	DESCRIPTION	QTY
1	5J7963	VALVE GROUP— (Separate Illustration)	1
2	4J7942	LINK	4
3	1H9696	SEAL	2
4	S1587	BOLT	2
5	3B4508	LOCKWASHER	6
6	9S1366	BOLT	1
7	5J5916	LEVER ASSEM.	1
8	2H5746	ADAPTER	2
9	5J5151	TUBE ASSEM.	1
10	4J522	SEAL	1
11	4B5167	WASHER	2
12	8J7240	HOUSING	2
13	6J2449	LEVER	1
14	8B4037	WASHER	2
15	3J4407	SEAL	2
16	S1571	BOLT	1
17	1D4717	NUT	2
18	3B4506	LOCKWASHER	10
19	S1588	BOLT	8
20	4J8425	GASKET	2
21	7F7983	BEARING	4
22	5F9199	PIN	4
23	8S7803	RETAINER	4
24	7H3912	BUSHING	2
25	4B7739	PLUG	1
26	8J2288	SPACER	1
27	5J5823	LEVER ASSEM.	1
28	3J532	LEVER	1
29	1B8706	KEY	2
30	S1590	BOLT	1
31	S1585	BOLT	2
32	8H9819	ADAPTER	1
33	8H9818	GASKET	2
34	8J135	PLUG	1
35	L1143	BOLT	2

C INDICATES CHANGE

119227

5J7526 HYDRAULIC TANK AND VALVE GROUP—Part 5 of 5—Type 1  
 Part of 5K6273 and 2P8032 Hydraulic Arrangements listed on Page 148  
 5J7963 Valve parts are shown on Page 176. AN ATTACHMENT

5J5726 HYDRAULIC TANK AND VALVE GROUP—Part 1 of 5—Type 2  
 Part of 5K6273 and 2P8032 Hydraulic Arrangements listed on Page 148. 5J7953 Valve parts are shown on Pages 174 and 175  
 Only separate parts serviced. When complete Group is required, order 9J646 shown on Pages 172F through 172K  
 AN ATTACHMENT

REF. NO.	PART NUMBER	DESCRIPTION	QTY
1	165	BOLT.....	2
2	3B4506	LOCKWASHER.....	6

3	5J5937	TUBE ASSEM.	1
4	6J2363	TUBE.....	1
5	5J5146	BRACKET.....	2
6	6H1717	BOLT.....	2
7	3B4508	LOCKWASHER.....	10
8	4B4280	WASHER.....	2
9	6J2362	TUBE.....	1
10	5J585	BOLT.....	2

11	3B8995	FITTING.....	2
12	1F1344	NUT.....	1
13	1T318	BOLT.....	2
14	3B4507	LOCKWASHER.....	2
15	7F8267	SEAL.....	1
16	3B1915	BOLT.....(L. 375", Long)	1
17	2H5330	BOLT.....(L. 875", Long)	1
18	7J3572	TUBE ASSEM.	1
19	3D9412	GASKET.....	1
20	7S8062	JOINT.....	1
21	5J9261	DISC.....	1
22	7J3570	TUBE ASSEM.	1
23	7J3573	GASKET.....	1
24	3B8996	FITTING.....	2
25	8F8997	NUT.....	1
26	3B9053	FITTING.....	1
27	8F8998	NUT.....	1
28	7J748	TUBE.....	1
29	5J5108	LEVER.....	1
30	5J7953	CONTROL VALVE GROUP..... (Separate Illustration)	1
31	5F9199	PIN.....	1
32	8S7803	RETAINER.....	1
33	8F3469	SEAL.....	4
34	7B3235	BOLT.....	6
35	7J6226	BRACKET.....	1
36	6H962	SPRING.....	1
37	5J5932	ROD.....	1
38	1J8489	END.....	1
39	5B9079	NUT.....	1
40	5J5110	LEVER.....	1
41	1B8706	KEY.....	1
42	1A2209	BOLT.....	1
43	5J5942	GASKET.....	1
44	5J619	BOLT.....	2
45	5J5942	GASKET.....	1
46	4B4279	WASHER.....	2
47	2B2006	BOLT.....	2

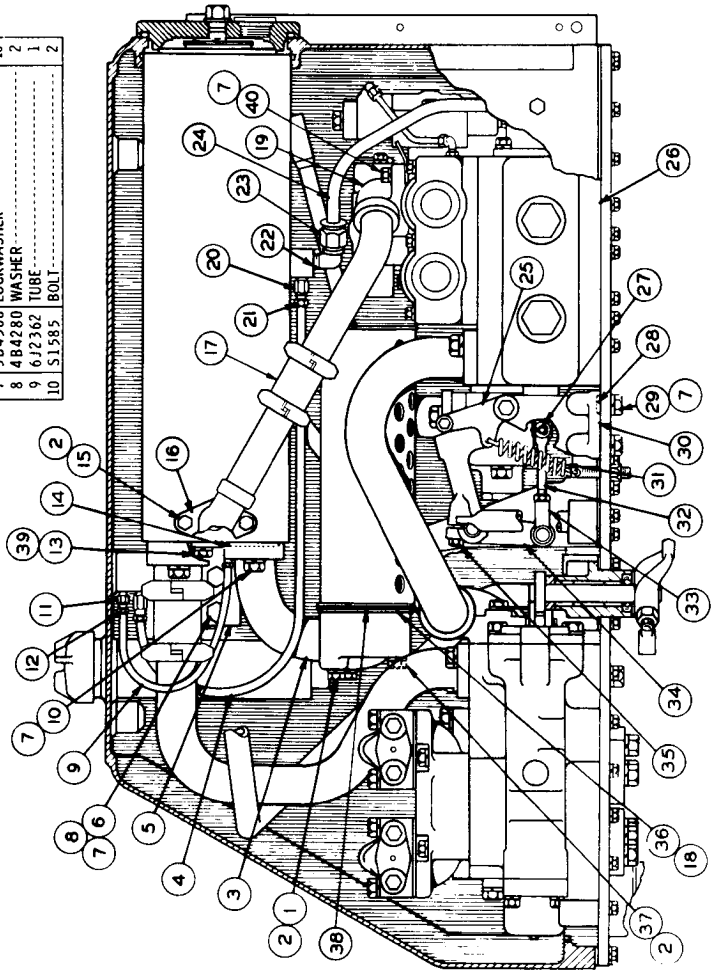

148056

REF. NO.	PART NUMBER	DESCRIPTION	QTY
1	515179	TUBE ASSEM.	1
1	612849	COUPLING ASSEM.	1
2	12N8198	SEAL ASSEM.	2

3	1A1460	BOLT	8
4	S1587	BOLT	2
5	3B4508	LOCKWASHER	12
6	S15195	BOLT	2

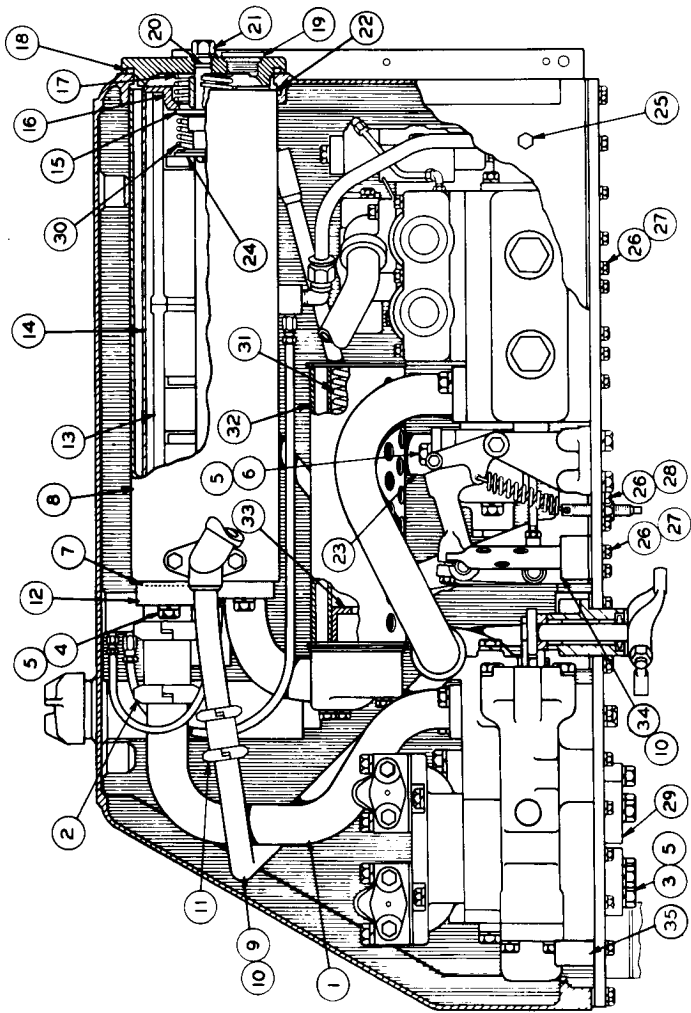

7	5E8000	SEAL	1
8	716096	TUBE ASSEM.	1
9	515202	TUBE ASSEM.	1
10	515166	GASKET	2
11	257070	JOINT ASSEM.	2
11	952082	SEAL ASSEM.	2
12	515157	TUBE ASSEM.	2
13	416064	ELEMENT ASSEM.	2
14	613795	SCREEN ASSEM.	1
15	23918	VALVE	1
16	411704	SEAT	1
17	62236	SPRING	1
18	719197	COVER	1
18	5L5032	SEAL	1
19	958010	PLUG	1
19	254078	SEAL	1
20	6F4855	SEAL	1
21	715586	BOLT	1
21	1H1200	PIN --(1.25" long)	1
21	715925	COTTER PIN --(1.125" long)	1
22	2K4472	SEAL	1
23	516022	TUBE	1
24	23917	RETAINER	1
25	954182	PLUG	1
25	317354	SEAL	1
26	1A2029	BOLT	11
27	3B4506	LOCKWASHER	8
28	4B5167	WASHER	3
29	3K2759	COVER	4
29	41523	SEAL	4
30	512826	SPRING	1
31	613911	SPRING	1
32	71773	TUBE ASSEM.	1
33	613908	ORIFICE	1
34	71772	TUBE ASSEM.	1
34	812381	BLOCK	2
35	812352	GASKET	2
35	3F4479	PIN	2

5J5726 HYDRAULIC TANK AND VALVE GROUP—Part 2 of 5—Type 5  
 Part of 5K6273 and 2P8032 Hydraulic Arrangements listed on Page 148. Only separate parts serviced  
 When complete Group is required, order 9J646 shown on Pages 172F through 172K. AN ATTACHMENT

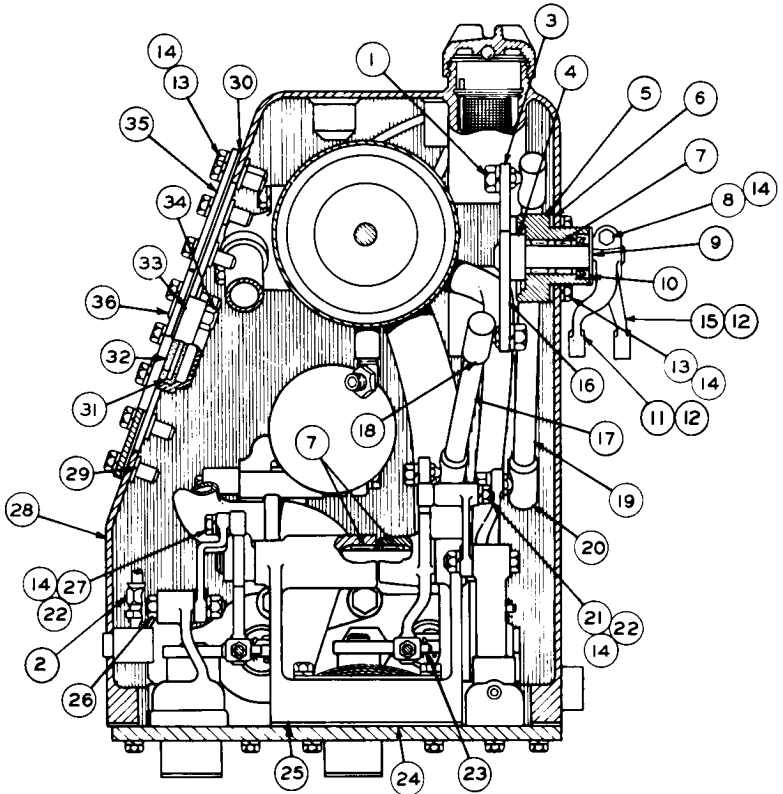

REF. NO.	PART NUMBER	DESCRIPTION	QTY
1	1B4205	NUT-----	4
	3B4508	LOCKWASHER-----	4
	3B8997	FITTING-----	1
	8F8998	NUT-----	1
2	5J5774	LEVER ASSEM.-----	1
	2H5746	ADAPTER-----	2
5	5J8102	HOUSING-----	2
	4J8425	GASKET-----	2
7	7F7983	BEARING-----	8
	S1571	BOLT-----	2
8	1D4717	NUT-----	2
	8B4037	WASHER-----	2
9	3J4407	SEAL-----	2
	7J7557	LEVER-----	2
11	1B8706	KEY-----	2
	S1594	BOLT-----	52
13	3B4506	LOCKWASHER-----	56
	5J5729	LEVER-----	1
14	5J5776	LEVER ASSEM.-----	1
	5J5765	ROD ASSEM.-----	1
17	2H9250	JOINT-----	2

19	5J5764	ROD ASSEM.-----	1
20	2H9250	JOINT-----	2
	4J3441	ROLLER-----	1
21	1B4203	NUT-----	2
	5F9199	PIN-----	2
23	8S7803	RETAINER-----	2
	5J5247	GASKET-----	1
24	7J779	BRACKET-----	1
	2J6602	PIN-----	2
25	1B4204	NUT-----	2
	3B4507	LOCKWASHER-----	2
26	2J8262	ROLLER-----	1
	7J775	TANK ASSEM.-----	1
27	6J2237	BOSS-----	44
	5J5160	GASKET-----	1
30	4J8252	GLASS-----	1
	4J8251	GROMMET-----	1
31	4J8250	RETAINER-----	1
	4J8265	NUT-----	4
32	6J2459	COVER ASSEM.-----	1
	5J5159	COVER-----	1
33	5J96	STUD-----	4

119225

5J5726 HYDRAULIC TANK AND VALVE GROUP—Part 3 of 5—Type 2  
 Part of 5K6273 and 2P8032 Hydraulic Arrangements listed on Page 148. Only separate parts serviced. When complete Group is required, order 9J646 shown on Pages 172F through 172K. AN ATTACHMENT

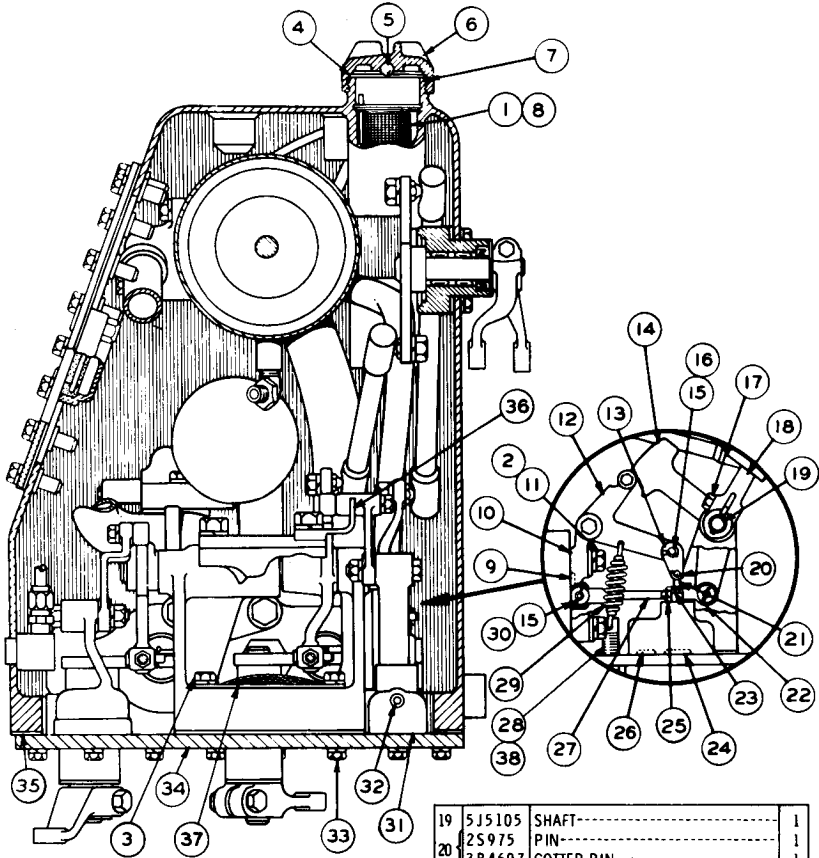

REF. NO.	PART NUMBER	DESCRIPTION	QTY
C 1	9J3050	STRAINER	1
2	3B4508	LOCKWASHER	2
3	2H3755	BOLT	2
	3B4505	LOCKWASHER	2
4	6H5139	PLATE	1
5	7B6368	BALL	1
6	7H1447	CAP	1
7	9H6454	GASKET	1
C 8	5K216	SEAL	1
9	4J519	SEAL	1
10	5J5109	BRACKET	1
11	S1585	BOLT	2
12	5J5071	LEVER	1
13	5J7518	LINK	2
14	5J5111	LEVER	1
15	5F9199	PIN	2
16	7H3912	BUSHING	1
17	S1588	BOLT	1
	4J7739	LEVER	1
18	1B8706	KEY	1

19	5J5105	SHAFT	1
	2S975	PIN	1
20	3B4607	COTTER PIN	1
21	5J7546	ROD	1
22	1J8489	END	1
23	6F612	NUT	1
24	5F7054	SEAL	1
25	5B9079	NUT	1
26	6F4855	SEAL	1
27	5J5933	ROD	1
	7J6227	EYE SCREW	2
28	1D4717	NUT	2
	5M2894	WASHER	2
29	6H962	SPRING	1
30	8S7803	RETAINER	1
31	5J7958	BODY GROUP	1
32	3D4603	PLUG	1
33	T320	BOLT	52
	3B4507	LOCKWASHER	52
34	8J2333	PLATE	1
35	5J5234	GASKET	1
36	6J4578	STOP	1
37	6J8118	SCREEN ASSEM.	1
38	8'6775	SEAL	2

C INDICATES CHANGE

148057

5J5276 HYDRAULIC TANK AND VALVE GROUP—Part 4 of 5—Type 2 Part of 5K6273 and 2P8032 Hydraulic Arrangements listed on Page 148 Only separate parts serviced. When complete Group is required, order 9J646 shown on Pages 172F through 172K. AN ATTACHMENT



5J5726 HYDRAULIC TANK AND VALVE GROUP—Part 5 of 5—Type 2  
 Part of 5K6273 and 2P8032 Hydraulic Arrangements listed on Page 148. 5J7963 Valve parts are shown on Page 176  
 Only separate parts serviced. When complete Group is required, order 9J646 shown on Pages 172E through 172K  
 AN ATTACHMENT

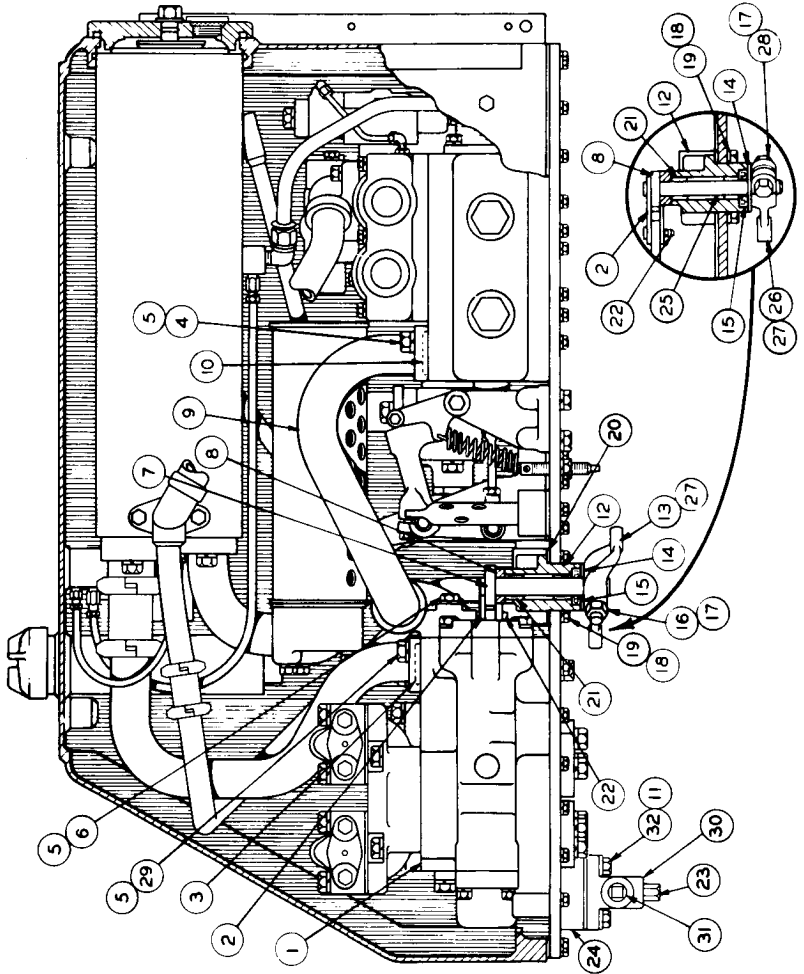

REF. NO.	PART NUMBER	DESCRIPTION	Q
1	5J7963	VALVE GROUP.....	1
2	4J7942	LINK.....	4
3	1H9696	SEAL.....	1
4	51587	BOLT.....	2
5	3B4508	LOCKWASHER.....	6
6	9S1366	BOLT.....	2
7	5J5916	LEVER ASSEM.....	2
8	2H5746	ADAPTER.....	2
9	5J5151	TUBE ASSEM.....	1
10	4J522	SEAL.....	1
11	4J523	SEAL.....	1
12	14B5167	WASHER.....	2
13	8J7240	HOUSING.....	2
14	6J2449	LEVER.....	1
15	8B4037	WASHER.....	2
16	51571	BOLT.....	2
17	1D4717	NUI.....	2
18	3B4506	LOCKWASHER.....	10
19	51588	BOLT.....	8
20	4J8425	GASKET.....	2
21	7F7983	BEARING.....	4
22	5F9199	PIN.....	4
23	8S7803	RETAINER.....	4
24	7H3912	BUSHING.....	2
25	4B7739	PLUG.....	1
26	8J2288	SPACER.....	1
27	5J5823	LEVER ASSEM.....	1
28	3J532	LEVER.....	1
29	1B8706	KEY.....	2
30	51590	BOLT.....	1
31	51585	BOLT.....	2
32	8H9819	ADAPTER.....	1
	8H9818	GASKET.....	2
	8J135	PLUG.....	1
	L1143	BOLT.....	2

148958

REF. PART NO.	DESCRIPTION	QTY
1	165 BOLT	2
2	384506 LOCKWASHER	6
3	315937 TUBE ASSEM.	1
4	612363 TUBE	1
5	515146 BRACKET	1
6	641717 BOLT	2
7	384508 LOCKWASHER	10
8	484280 WASHER	1
9	612362 TUBE	2
10	51585 BOLT	2
11	388995 FITTING	2
12	1F1344 NUT	1

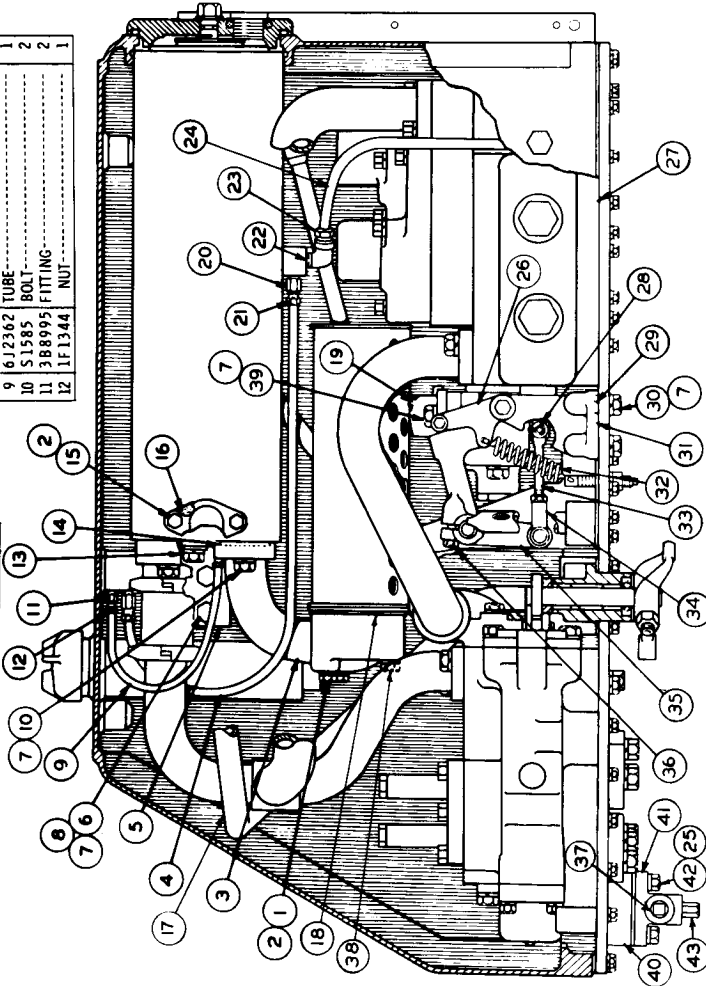

13	T318 BOLT	2
14	384507 LOCKWASHER	2
15	484279 WASHER	2
16	7F8267 SEAL	1
17	51588 BOLT	2
18	3D9412 GASKET	1
19	6J236 TUBE ASSEM.	1
20	5J9261 DISC	1
21	5J5942 GASKET	2
22	516022 TUBE ASSEM.	2
23	388996 FITTING	2
24	8F8997 NUT	1
25	389053 FITTING	1
26	8F8998 NUT	1
27	7J748 TUBE	1
28	485167 WASHER	1
29	5J5108 LEVER	2
30	9J643 CONTROL VALVE GROUP	1
31	5F9199 PIN	1
32	8S7803 RETAINER	1
33	8F3469 SEAL	4
34	783235 BOLT	4
35	716226 BRACKET	4
36	6H962 SPRING	1
37	5J5932 ROD	1
38	1J8489 END	1
39	5B9079 NUT	1
40	5J5110 LEVER	1
41	1B8706 KEY	1
42	1A2209 BOLT	1
43	8J135 PLUG	1
44	51619 BOLT	2
45	51595 BOLT	2
46	8J2288 SPACER	1
47	8H9819 ADAPTER	1
48	8H9818 GASKET	2
49	L1143 BOLT	2
50	487739 PLUG	1

148909

9J646 TANK AND VALVE GROUP—Part 1 of 5  
 Part of 5K6273 and 2F8032 Hydraulic Arrangements listed on Page 148  
 9J643 Valve parts are shown on Pages 176A and 176B. AN ATTACHMENT

9J646 TANK AND VALVE GROUP—Part 2 of 5  
 Part of 5K6273 and 2F8032 Hydraulic Arrangements listed on Page 148  
 AN ATTACHMENT

REF. NO.	PART NUMBER	DESCRIPTION	QTY
1	9J664	TUBE ASSEM.	1
2	6L2849	COUPLING	1
3	8J2352	GASKET	2

4	5L1595	BOLT	2
5	3B4508	LOCKWASHER	2
6	9J4028	TUBE	1

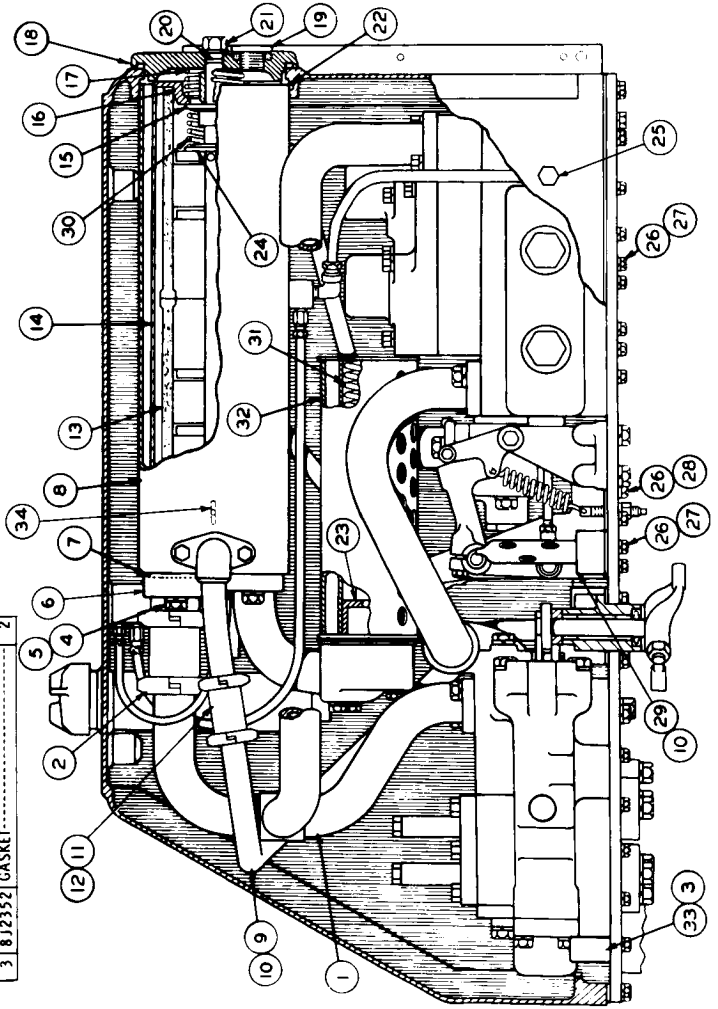

7	5F8000	SEAL	1
8	7J6096	TUBE ASSEM.	1
9	5J5202	TUBE ASSEM.	1
10	5J5166	GASKET	2
11	2S7070	JOINT ASSEM.	1
12	9S2082	SEAL ASSEM.	2
13	4J6064	ELEMENT ASSEM.	2
14	6J3795	SCREEN ASSEM.	1
15	2J918	VALVE	1
16	4J1704	SPRING	1
17	6J2236	SPRING	1
18	7J9197	COVER	1
19	5L5032	SEAL	1
20	9S8010	PLUG	1
21	2S4078	SEAL	1
22	6F4855	SEAL	1
23	7J5586	BOLT	1
24	2K4472	SEAL	1
25	6J3908	ORIFICE	1
26	2J917	RETAINER	1
27	1H1200	PIN	1
28	9S4182	PLUG	1
29	3J7354	SEAL	1
30	1A2029	BOLT	11
31	3B4506	LOCKWASHER	8
32	4B5167	WASHER	3
33	7J772	TUBE ASSEM.	1
34	5J2926	SPRING	1
35	6J3911	SPRING	1
36	7J773	TUBE ASSEM.	1
37	8J2381	BLOCK	2
38	3F4479	PIN	2
39	7J5925	PIN	1

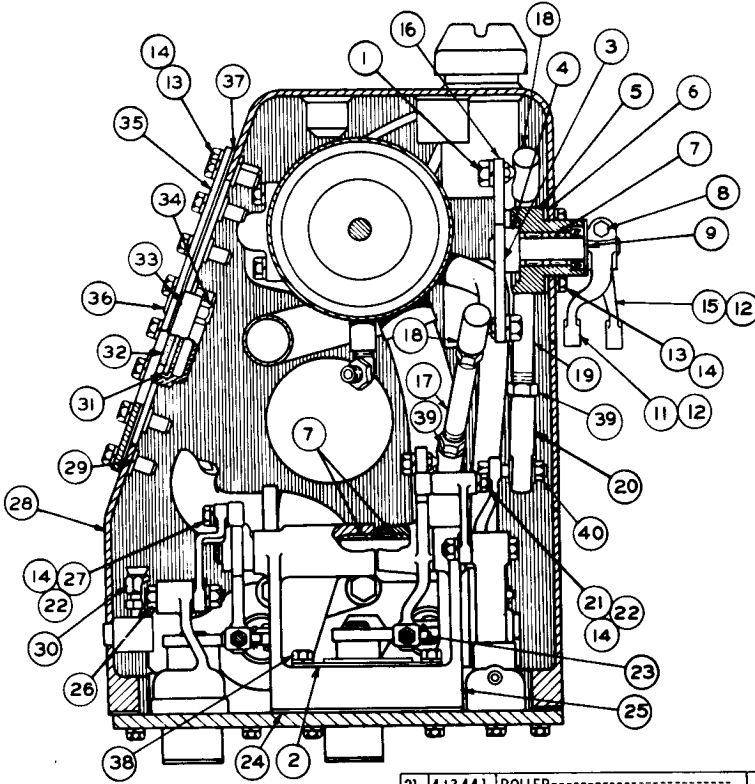

REF. NO.	PART NUMBER	DESCRIPTION	QTY
1	1B4205	NUT-----	3
	3B4508	LOCKWASHER-----	3
2	6J8118	SCREEN ASSEM.-----	1
3	8J6135	LEVER ASSEM.-----	1
4	2H5746	ADAPTER-----	2
5	5J8102	HOUSING-----	2
6	4J8425	GASKET-----	2
7	9H8751	BEARING-----	8
8	S1571	BOLT-----	2
	1D4717	NUT-----	2
9	8B4037	WASHER-----	2
11	7J7557	LEVER-----	1
12	1B8706	KEY-----	2
13	S1594	BOLT-----	52
14	3B4506	LOCKWASHER-----	54
15	5J5729	LEVER-----	1
16	9J652	LEVER ASSEM.-----	1
17	8J6101	ROD-----	1
18	8J6171	ROD END ASSEM.-----	3
19	5J7702	ROD-----	1
20	4D4065	ROD END-----	1

21	4J3441	ROLLER-----	1
22	1B4203	NUT-----	2
	5F9199	PIN-----	2
23	8S7803	RETAINER-----	2
	5J5247	GASKET-----	1
24	7J779	BRACKET-----	1
	2J6602	PIN-----	2
26	1B4204	NUT-----	2
	3B4507	LOCKWASHER-----	2
27	2J8262	ROLLER-----	1
28	9J645	TANK ASSEM.-----	1
29	6J2237	BOSS-----	44
	3B8997	FITTING-----	1
30	8F8998	NUT-----	1
31	4J8252	GLASS-----	1
32	4J8251	GROMMET-----	1
33	8J6913	RETAINER-----	1
34	4J8265	NUT-----	4
35	9J654	COVER ASSEM.-----	1
36	8J6910	STUD-----	4
37	5J5160	GASKET-----	1
	2H3755	BOLT-----	2
38	3B4505	LOCKWASHER-----	2
39	1B4430	NUT-----	4
	S1587	BOLT-----	1
40	1K6872	NUT-----	1

148911

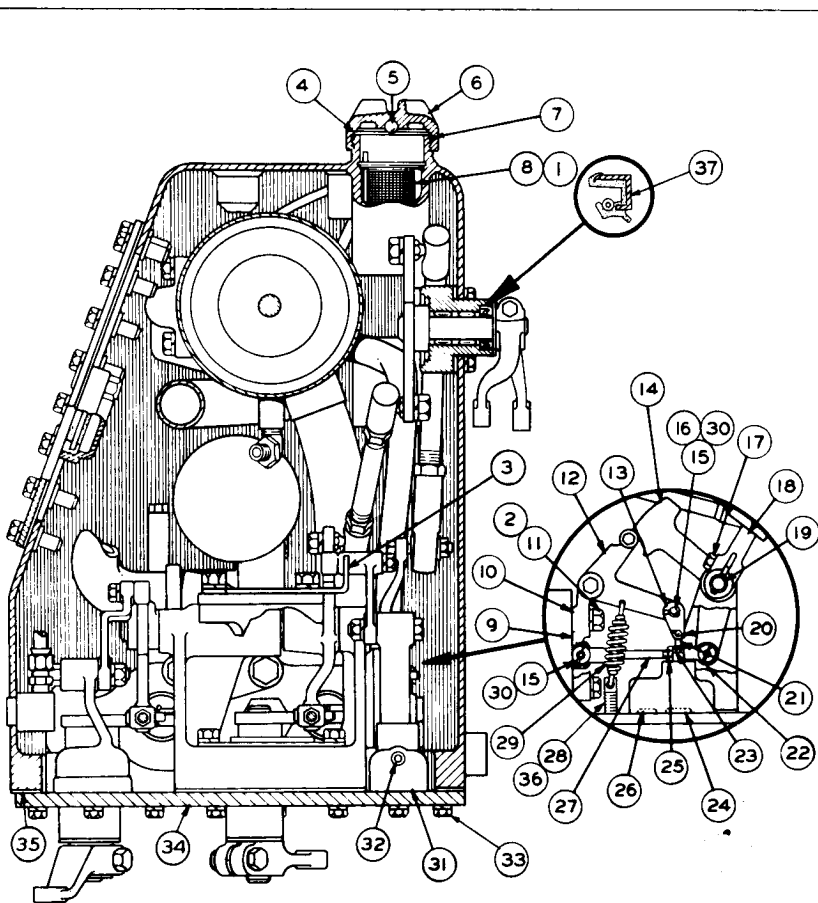

REF. NO.	PART NUMBER	DESCRIPTION	QTY
1	5K216	SEAL	1
2	3B4508	LOCKWASHER	2
3	6J4578	STOP	1
4	6H5139	PLATE	1
5	7B6368	BALL	1
6	7H1447	CAP	1
7	9H6454	GASKET	1
8	9J3047	STRAINER	1
9	4J519	SEAL	1
10	5J5109	BRACKET	1
11	S1585	BOLT	2
12	5J5071	LEVER	1
13	5J7518	LINK	2
14	5J5111	LEVER	1
15	5F9199	PIN	2
16	7H3912	BUSHING	1
17	S1588	BOLT	1
18	4J7739	LEVER	1
18	1B8706	KEY	1
19	9J653	SHAFT	1

20	2S975	PIN	1
	3B4607	COTTER PIN	1
21	5J7546	ROD	1
22	1J8489	END	1
23	6F612	NUT	1
24	5F7054	SEAL	1
25	5B9079	NUT	1
26	6F4855	SEAL	1
27	5J5933	ROD	1
	7J6227	EYE SCREW	2
28	1D4717	NUT	2
	5M2894	WASHER	2
29	6H962	SPRING	1
30	8S7803	RETAINER	2
31	5J7958	BODY GROUP	1
32	3D4603	PLUG	1
	T320	BOLT	52
33	3B4507	LOCKWASHER	52
34	8J2333	PLATE	1
35	5J5234	GASKET	1
36	8J6775	SEAL	2
37	3J4407	SEAL	2

148912

9J646 TANK AND VALVE GROUP—Part 4 of 5  
 Part of 5K6273 and 2P8032 Hydraulic Arrangements listed on Page 148  
 AN ATTACHMENT

148913

REF. NO.	PART NUMBER	DESCRIPTION	QTY
1	1517963	VALVE GROUP— (Separate Illustration)	1
2	417942	LINK	4
3	119696	SEAL	2
4	51587	BOLT	2
5	384508	LOCKWASHER	18
6	951366	BOLT	2
7	816133	LEVER ASSEM.	1
8	2H5746	ADAPTER	2
9	515151	TUBE ASSEM.	1
10	41522	SEAL	1
11	418425	GASKET	5
12	817240	HOUSING	2
13	612449	LEVER	2
14	884037	WASHER	1
15	134407	SEAL	2
16	51571	BOLT	1
17	1D4717	NUT	2
18	384506	LOCKWASHER	10
19	51588	BOLT	8
20	783235	BOLT	2
21	948751	BEARING	4
22	5F9199	PIN	4
23	857803	RETAINER	4
24	7H3912	BUSHING	4
25	1A1460	BOLT	2
26	3K2759	COVER	8
27	816132	LEVER ASSEM.	4
28	3J532	LEVER	1
29	188706	KEY	1
30	51590	BOLT	2
31	51585	BOLT	1
32	51585	BOLT	4

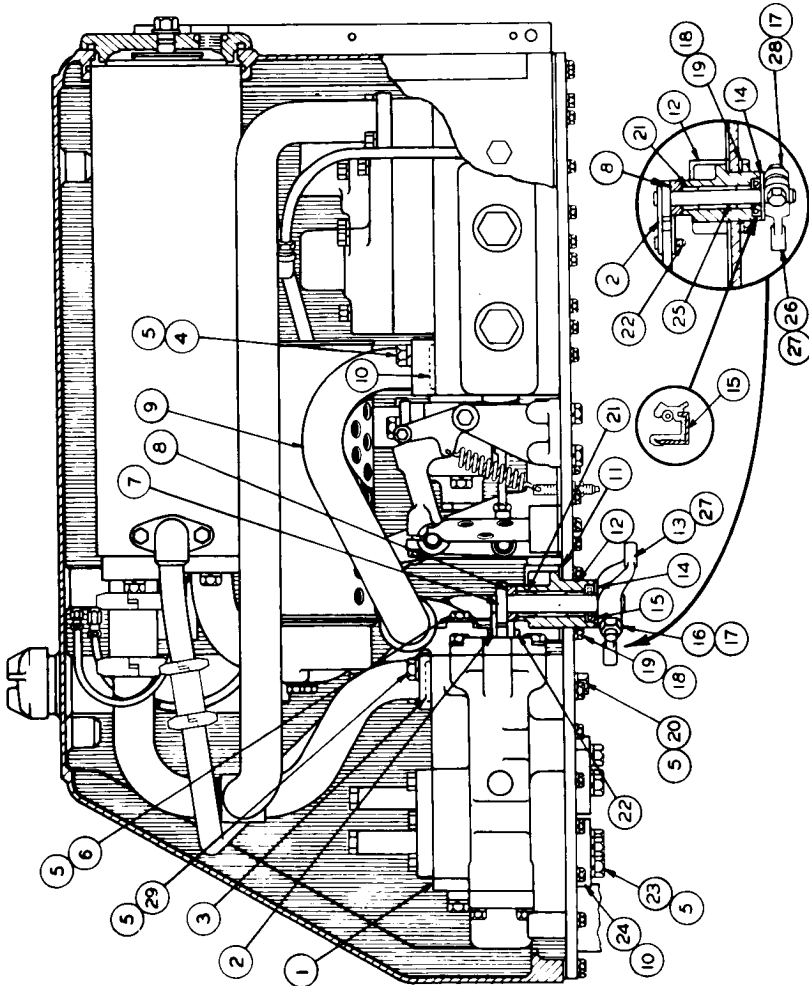

9J1646 TANK AND VALVE GROUP—Part 5 of 5  
 Part of 5K6273 and 2F8032 Hydraulic Arrangements listed on Page 148  
 5J7963 Valve parts are shown on Page 176  
 AN ATTACHMENT

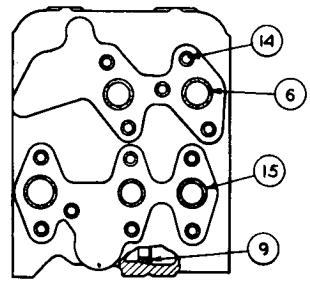
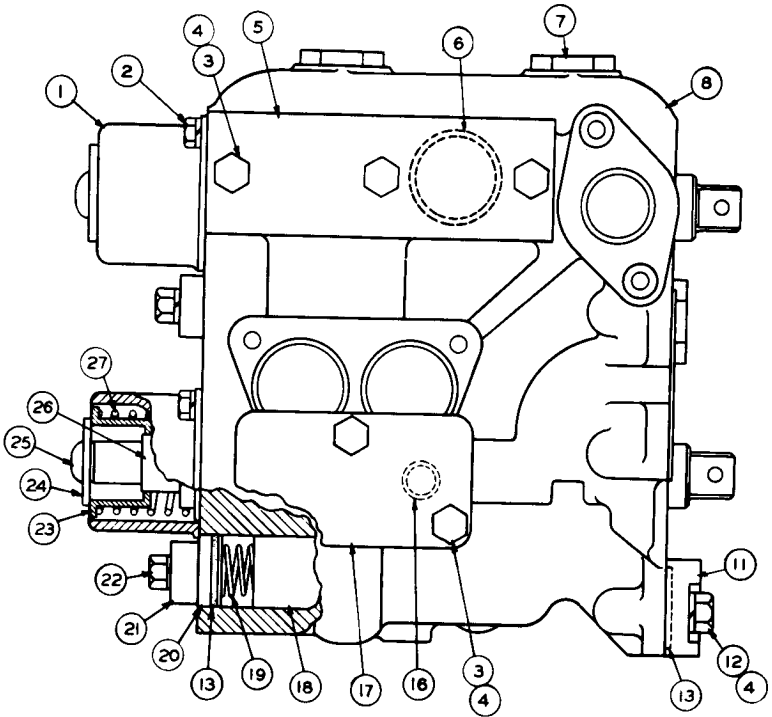

REF. NO.	PART NUMBER	DESCRIPTION	QTY
C 1	8J2334	RETAINER-----	2
	S1594	BOLT----- (1 in. long)-----	4
		-OR-	
C 2	S509	BOLT----- (.75 in. long)-----	4
	3B4506	LOCKWASHER-----	4
3	S1585	BOLT-----	6
4	3B4508	LOCKWASHER-----	8
5	4J4753	COVER-----	1
6	4J523	SEAL-----	5
	3J1553	PLUG-----	3
	4J5267	SEAL-----	3
8	5J7962	BODY GROUP-----	1
9	2J5437	INSERT-----	2
11	5J9066	COVER-----	1
12	7B3235	BOLT-----	2
13	4J519	SEAL-----	3
14	8F3469	SEAL-----	12
15	4J522	SEAL-----	2
16	4J521	SEAL-----	2
17	5J5161	COVER-----	1
18	4J7415	VALVE-----	2
19	2J5845	SPRING-----	2
20	2J5820	PLUG-----	2

21	4J2923	FLANGE-----	2
	T320	BOLT-----	4
22	3B4507	LOCKWASHER-----	4
23	2J4860	SPACER-----	2
24	2J7258	WASHER-----	2
25	2J1712	SCREW-----	2
26	3J3096	SPACER-----	2
27	4J3789	SPRING-----	2

C INDICATES CHANGE

119412

5J7955 CONTROL VALVE GROUP  
 Part of 5J5724 Hydraulic Tank and Valve, 5J5723 and 9J635  
 Field Conversion Groups shown on Pages 155, 192 and 192A

C INDICATES CHANGE

REF. NO.	PART NUMBER	DESCRIPTION	QTY
	4J2184	FITTING	2
	4J2207	NUT	1
	4J2208	SLEEVE	1
	3J7354	"O" RING	1
	2 S1594	BOLT	4
	3B4506	LOCKWASHER	4
	4 S1585	BOLT	3
	5B4508	LOCKWASHER	11
	6 S18316	HOUSING	1
	7 1D4566	BOLT	3
	8 S18359	BODY	1
	9 4J523	SEAL	9
	10 8F3469	SEAL	12
	11 3J1553	PLUG	4
	12 4J5267	SEAL	3
	13 6J3620	COVER	1
	14 5J5274	VALVE GROUP (See Separate Illustration)	1
	15 S1573	BOLT	3
	16 4J522	SEAL	2
	17 L1329	BOLT	2
	18 3J8878	VALVE GROUP (See Separate Illustration)	1
	19 4J521	SEAL	2
	20 4J7415	VALVE	4
	21 1J8960	SPRING	4
	22 8J285	PLATE	1
	23 6J6289	VALVE GROUP (See Separate Illustration)	1
	24 5J5931	TUBE (-05, 95" Long)	1
	25 4B4280	WASHER	2
	26 7J3573	GASKET	1

113879

C

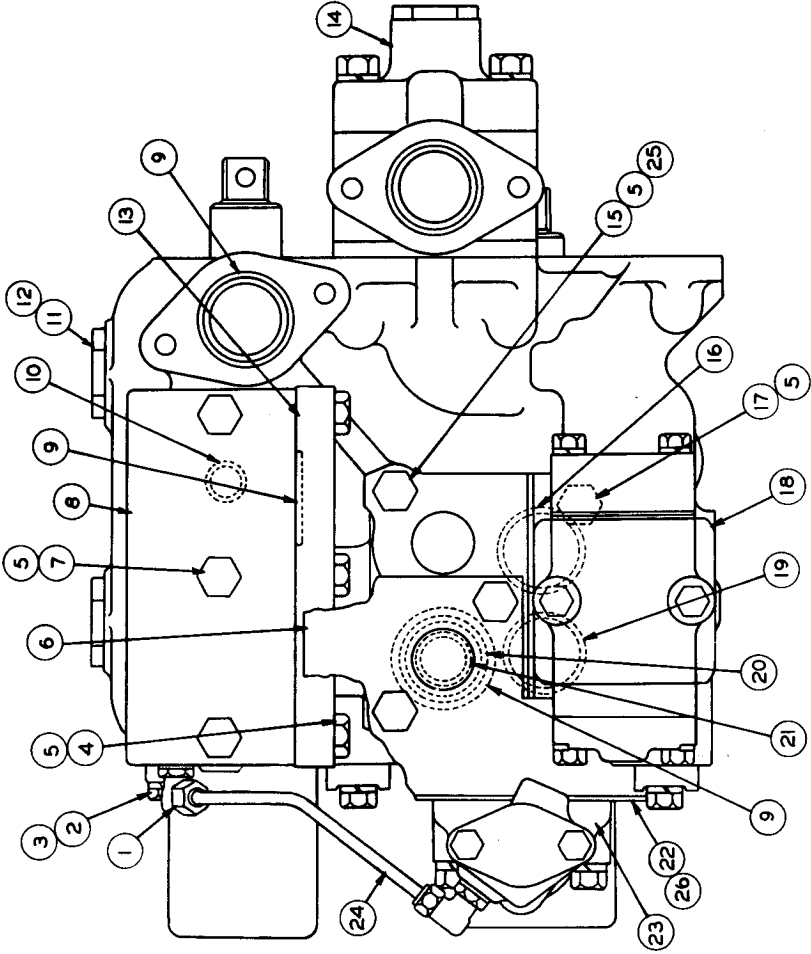

5J7963 CONTROL VALVE GROUP—Part 1—Type 1  
 Part of 5J5724 Hydraulic Tank and Valve Group, Hydraulic Tank and Valve and 6J7041 and 5J5726 Hydraulic Tank and Valve Groups shown on Pages 151, 155A, 156, 160, 163A, 164, 167A, 168 and 172A  
 6J6289, 3J8878 and 5J5274 Valve parts are shown on Pages 177 and 178



5J7953 CONTROL VALVE GROUP—Part 2—Type 1  
 Part of 5J5724 Hydraulic Tank and Valve Group, Hydraulic Tank and Valve and 6J7041 and  
 5J5726 Hydraulic Tank and Valve Groups shown on Pages 151, 155A, 156, 160, 163A, 164, 167A, 168 and 172A

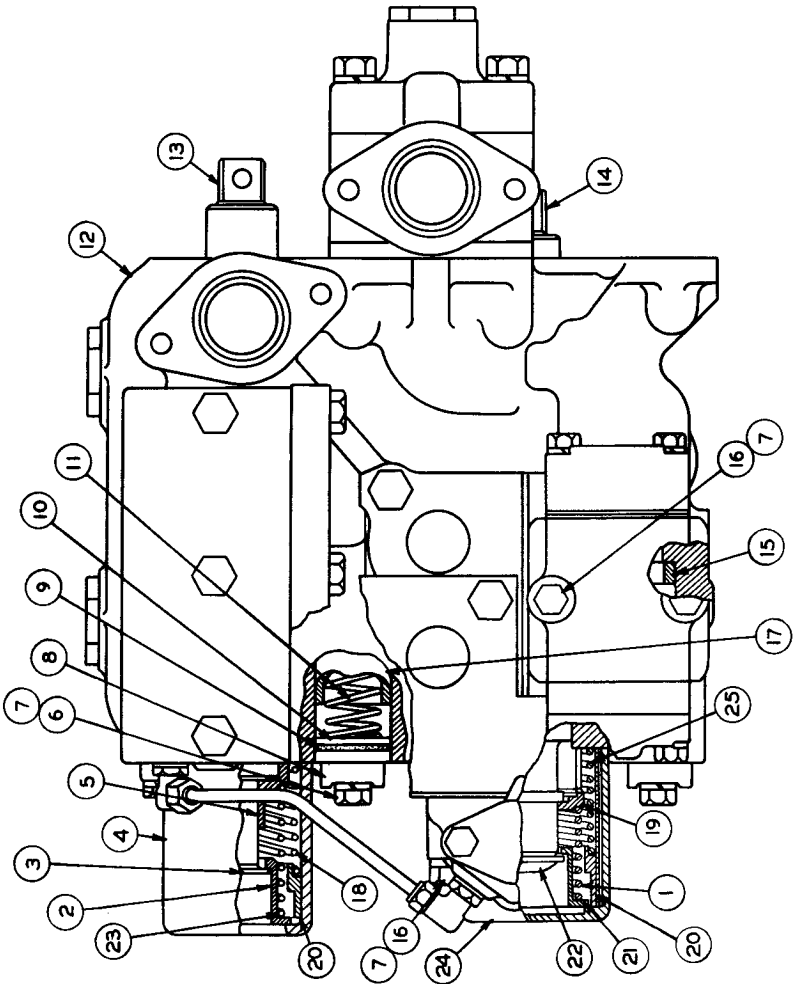

REF NO.	PART NUMBER	DESCRIPTION	QTY.
1	4J18148	SPRING-----(Inner)	1
2	4J7953	SPACER-----	1
3	4J7910	SCREW-----	1
4	4J8147	RETAINER-----	1
5	4J7932	SPACER-----	1
6	T320	BOLT-----	4
7	3B4507	LOCKWASHER-----	8
8	4J2923	FLANGE-----	2
9	4J519	SEAL-----	2
10	2J5820	PLUG-----	2
11	2J5845	SPRING-----	2
12	6J3771	BODY GROUP-----	1
13	Not Serv	BODY-----	1
13	Not Serv	STEM-----	1
14	Not Serv	STEM-----	1
15	2J5437	INSERT-----	2
16	1D4707	BOLT-----	4
17	2J5436	VALVE-----	2
18	4J8149	SPRING-----	1
19	6J3396	SPACER-----	1
20	6J4618	SPACER-----	2
21	6J3395	SPACER-----	1
22	2J1712	SCREW-----	1
22	V531	WASHER-----	1
C 23	8F1560	SPRING----- (Inner)	1
C 24	8J1759	RETAINER-----	1
C 25	7J1277	SPRING----- (Outer)	1

C INDICATES CHANGE

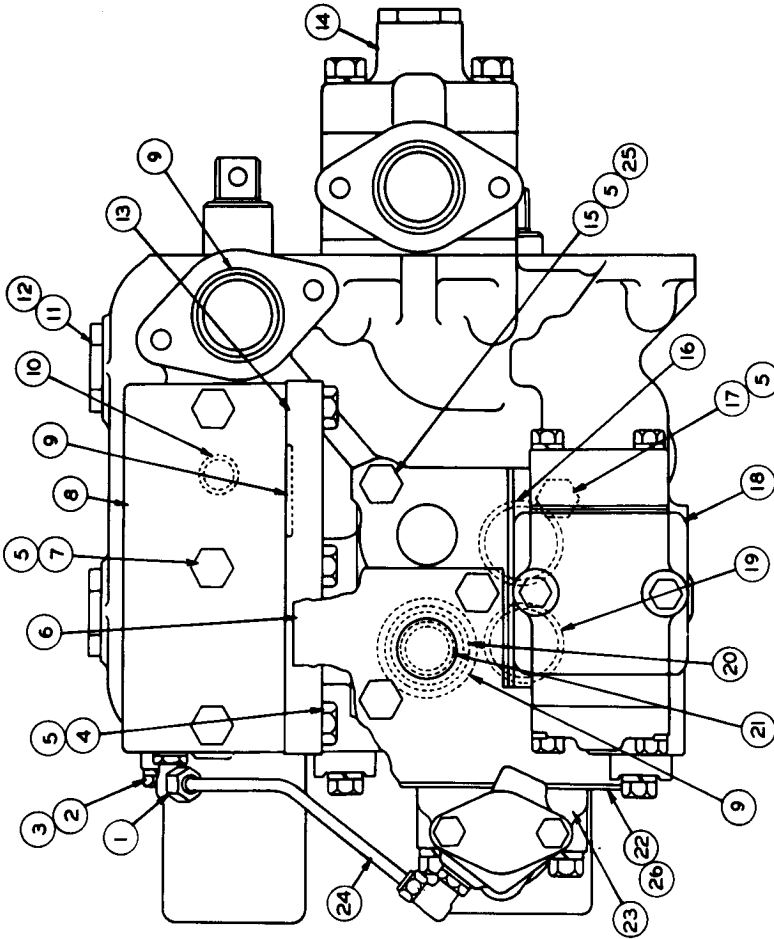

REF. NO.	PART NUMBER	DESCRIPTION	QTY
	4J2184	FITTING	2
	4J2207	NUT	1
	4J2208	SLEEVE	1
	3J7354	"O" RING	1
	2 S1594	BOLT	4
	3 384506	LOCKWASHER	4
	4 S1585	BOLT	3
	5 384508	LOCKWASHER	11
	6 5J8316	HOUSING	1
	7 1D4566	BODY	3
	8 5J8359	BODY	1
	9 4J523	SEAL	9
	10 8F3469	SEAL	12
	11 3J1553	PLUG	4
	12 4J5267	SEAL	3
	13 3J5317	COVER	3
	14 5J5274	VALVE GROUP	1
		(See Separate Illustration)	
	15 S1573	BOLT	3
	16 4J522	SEAL	2
	17 L1329	BOLT	2
	18 3J8878	VALVE GROUP	1
		(See Separate Illustration)	
	19 4J521	SEAL	2
	20 4J7415	VALVE	4
	21 4J7066	SPRING	4
	22 8J285	PLATE	1
	23 6J6289	VALVE GROUP	1
		(See Separate Illustration)	
	24 5J5931	TUBE	1
	25 484280	WASHER	2
	26 7J3573	GASKET	1

C INDICATES CHANGE

148907

5J7953 CONTROL VALVE GROUP—Part 1—Type 2

Part of 5J5724 Hydraulic Tank and Valve Group, Hydraulic Tank and Valve, 6J7041 and 5J5726 Hydraulic Tank and Valve Groups shown on Pages 151, 156, 160, 164 and 168. 6J6289, 3J8878 and 5J5274 Valve parts are shown on Pages 177 and 178

5J7953 CONTROL VALVE GROUP—Part 2—Type 2  
 Part of 5J5724 Hydraulic Tank and Valve Group, Hydraulic Tank and Valve, 6J7041 and 5J5726  
 Hydraulic Tank and Valve Groups shown on Pages 151, 156, 160, 164 and 168

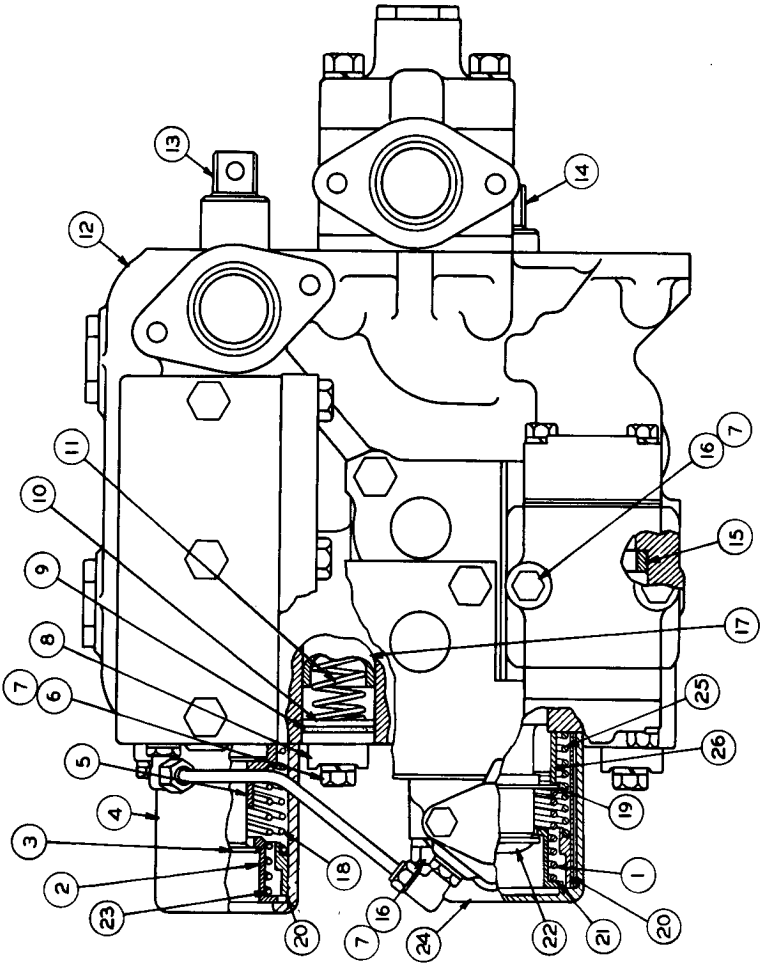

REF NO	PART NUMBER	DESCRIPTION	QTY
1	4J8148	SPRING-----(Inner)	1
2	4J7953	SPACER-----	1
3	4J7910	SCREW-----	1
4	4J8147	RETAINER-----	1
5	4J7932	SPACER-----	1
6	T320	BOLT-----	4
7	3B4507	LOCKWASHER-----	8
8	4J2923	FLANGE-----	2
9	4J519	SEAL-----	2
10	2J5820	PLUG-----	2
11	2J5845	SPRING-----	2
12	6J3771	BODY GROUP-----	2
12	Not Serv	BODY-----	1
13	Not Serv	STEM-----	1
14	Not Serv	STEM-----	1
15	2J5437	INSERT-----	2
16	1D4707	BOLT-----	4
C 17	2J7415	VALVE-----	2
18	4J8149	SPRING-----	1
C 19	8J3575	WASHER-----	1
20	6J4618	SPACER-----	2
21	6J3395	SPACER-----	1
22	2J1712	SCREW-----	1
23	V531	WASHER-----	1
23	8F1560	SPRING----- (Inner)	1
24	8J1759	RETAINER-----	1
25	7J1277	SPRING----- (outer)	1
C 26	8J3576	SPACER-----	1

C INDICATES CHANGE

148908

REF. NO.	PART NUMBER	DESCRIPTION	QTY.
1	9S8010	PLUG	2
2	2S4078	SEAL	2
3	4J7066	SPRING	2
4	4J7415	VALVE	2
5	9J631	SEAL	1
6	3J1553	MANIFOLD	3
7	4J5267	PLUG	3
8	8F3469	SEAL	12
9	4J523	SEAL	6
10	5J5274	VALVE GROUP (Separate Illustration)	1
11	4J522	SEAL	4
12	4J521	SEAL	1
13	8J6089	VALVE GROUP (Separate Illustration)	1
14	6J5804	BAFFLE	1
15	S1573	BOLT	4
16	3B4508	LOCKWASHER	4
17	2B2006	BOLT	3
	8J6126	HOUSING	1

148361

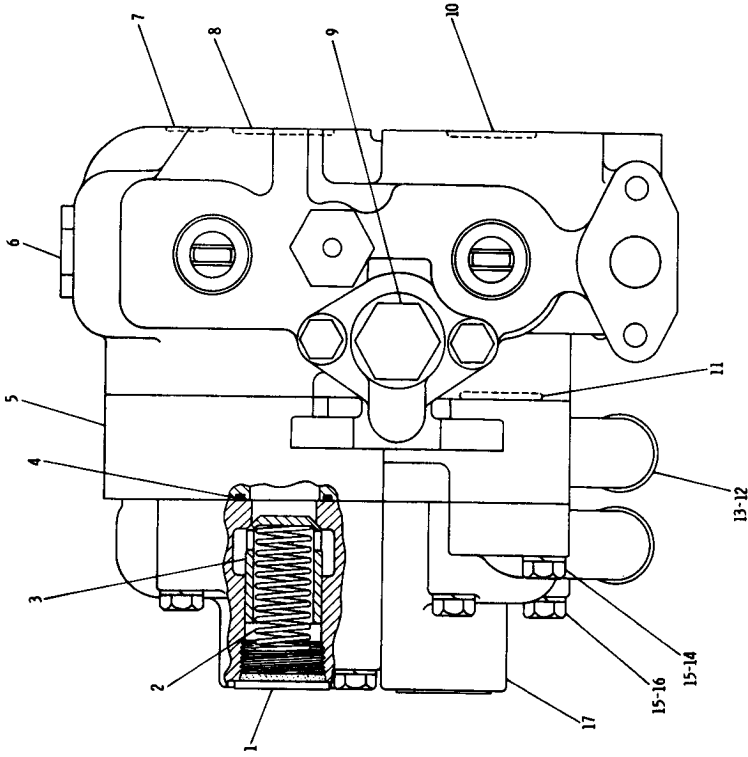

9J643 CONTROL VALVE GROUP—Part 1

Part of 9J644, 9J642, 9J641 and 9J646 Hydraulic Tank and Valve Groups shown on Pages 155F, 163E, 167E and 172K  
 5J9106, 5J5274 and 8J6089 Valve parts are shown on Pages 177, 178 and 178A

9J643 CONTROL VALVE GROUP—Part 2  
 Part of 9J644, 9J642, 9J641 and 9J646 Hydraulic Tank and Valve Groups shown on Pages 155F, 163E, 167E and 172K

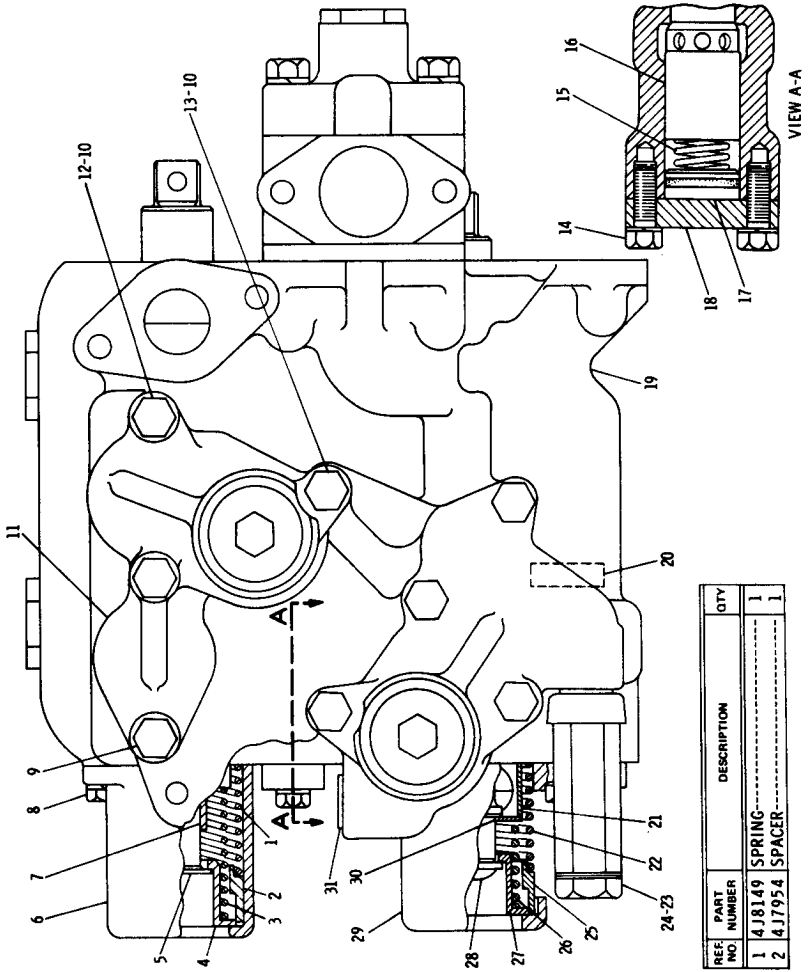

3	8F1560	SPRING	1
4	4J7953	SPACER	1
5	4J7910	SCREW	1
6	4J8147	RETAINER	1
7	4J7932	SPACER	1
8	S1594	BOLT	4
8	3B4506	LOCKWASHER	4
9	1B2886	BOLT	1
10	3B4508	LOCKWASHER	3
11	8J6128	HOUSING	1
12	282006	BOLT	2
13	9J8260	BOLT	1
14	1T320	BOLT	4
14	3B4507	LOCKWASHER	4
15	2J5845	SPRING	2
16	4J7415	VALVE	2
17	2J5820	PLUG	2
17	4J519	SEAL	2
18	4J2923	COVER	2
19	6J3771	VALVE GROUP (Includes)	1
20	2J5437	INSERT	2
21	8J3576	SPACER	1
22	7J1277	SPRING	1
23	5J9106	VALVE GROUP (Separate Illustration)	1
24	6J5804	BAFFLE	1
25	6J4618	SPACER	1
26	4J8148	SPRING	1
27	6J3395	SPACER	1
28	2J1712	SCREW	1
28	V551	WASHER	1
29	8J1759	RETAINER	1
30	8J3575	WASHER	1
30	9S8006	PLUG	1
31	2M9780	SEAL	1

148362

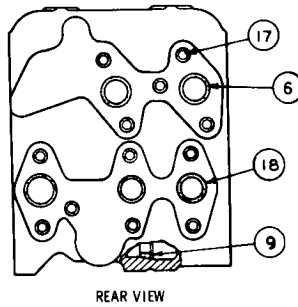
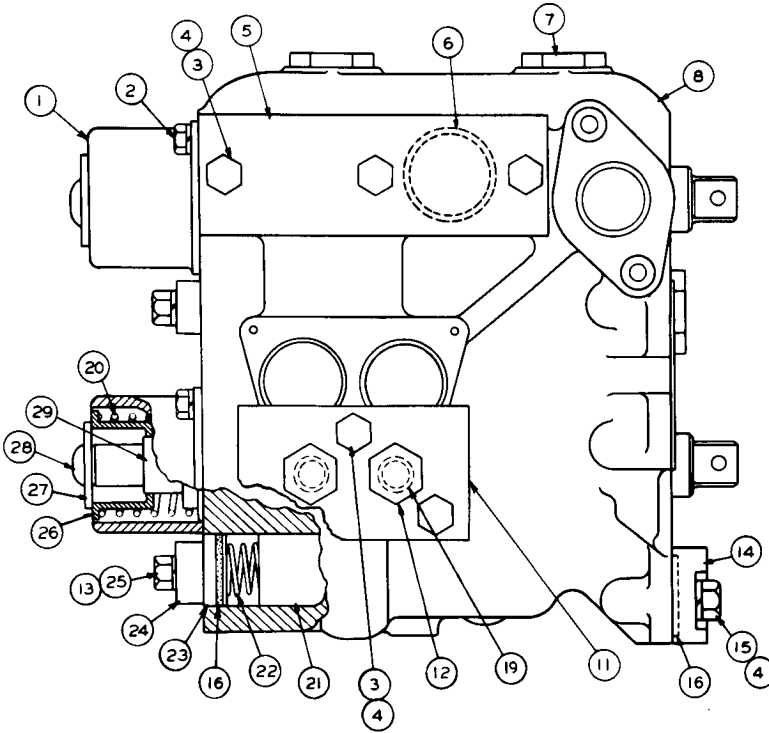

REAR VIEW

REF. NO.	PART NUMBER	DESCRIPTION	QTY
C 1	8J2334	RETAINER-----	2
	S1594	BOLT----- (1 in. long)-----	4
		OR-----	
C 2	S509	BOLT----- (1.75 in. long)-----	4
	3B4506	LOCKWASHER-----	4
	3S1585	BOLT-----	6
	3B4508	LOCKWASHER-----	8
	4J4753	COVER-----	1
	4J523	SEAL-----	5
	3J1553	PLUG-----	3
	4J5267	SEAL-----	3
	5J7962	BODY GROUP-----	1
	2J5437	INSERT-----	2
	8J2289	COVER-----	1
	5J9106	VALVE GROUP-----	2
		(Separate Illustration)	
	3B4507	LOCKWASHER-----	4
	5J9066	COVER-----	1
	7B3235	BOLT-----	2
	4J519	SEAL-----	3
	8F3469	SEAL-----	12
	4J522	SEAL-----	2
	4J521	SEAL-----	2
	4J3789	SPRING-----	2
	4J7415	VALVE-----	2
C 22	2J5845	SPRING-----	2

23	2J5820	PLUG-----	2
24	4J2923	FLANGE-----	2
25	T320	BOLT-----	4
26	2J4860	SPACER-----	2
27	2J7258	WASHER-----	2
28	2J1712	SCREW-----	2
29	3J3096	SPACER-----	2

C INDICATES CHANGE

119413

5J7963 CONTROL VALVE GROUP  
Part of 5J5726 Hydraulic Tank & Valve Group shown on Page 172  
AN ATTACHMENT

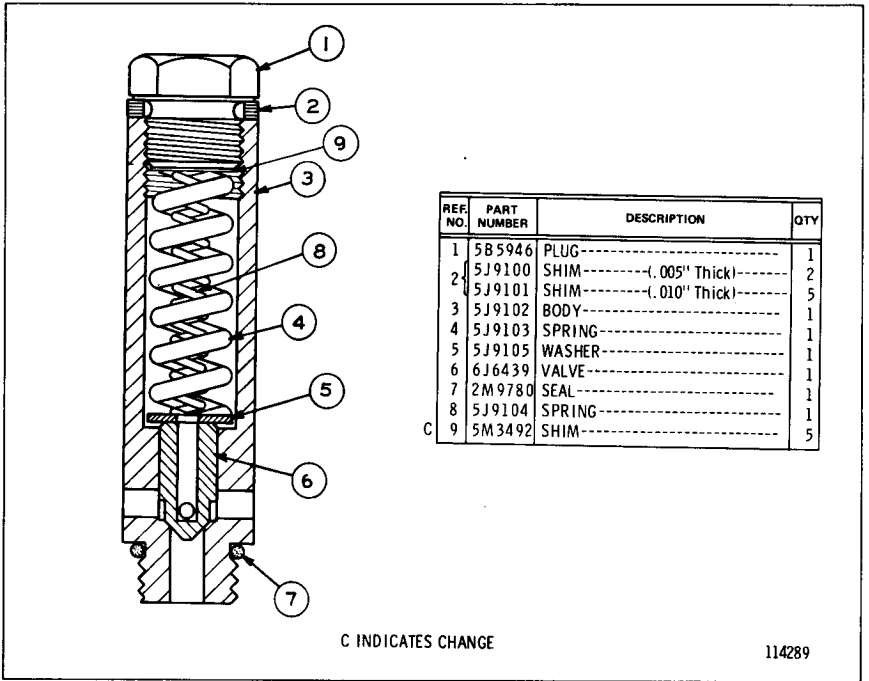

5J9106 TILT RELIEF VALVE GROUP  
Part of 5J7963 Control Valve Group  
AN ATTACHMENT

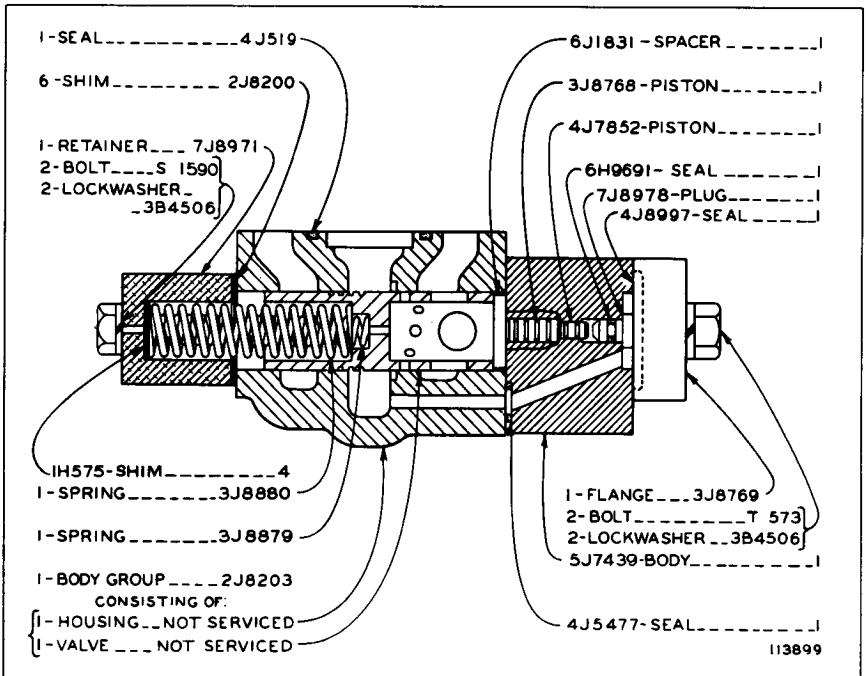

6J6289 TILT RELIEF VALVE GROUP  
Part of 5J7953 Control Valve Group shown on Page 174





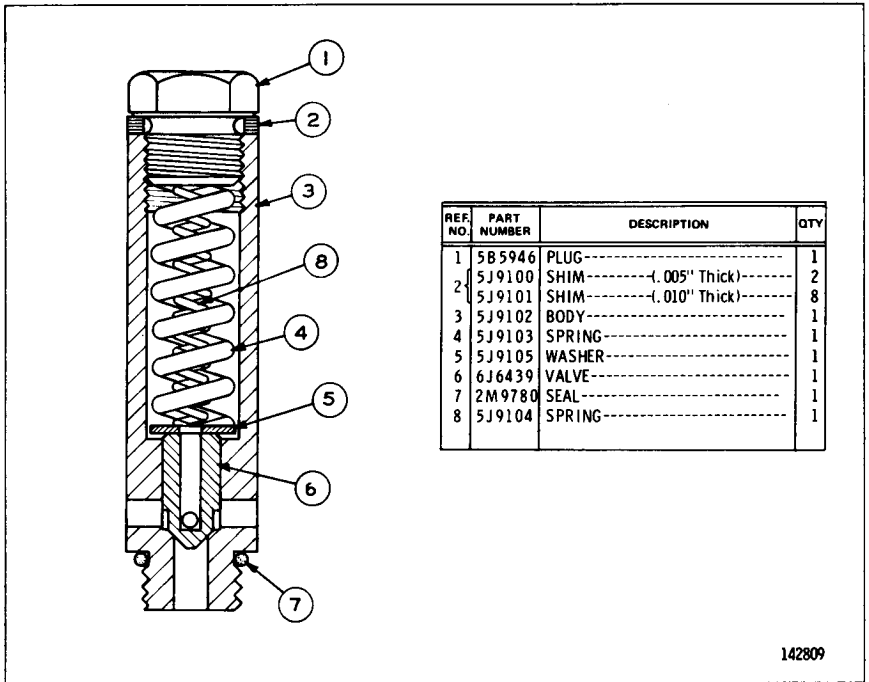

142809

8J6089 RELIEF VALVE GROUP  
 Part of 9J643 Control Valve Group shown on Page 175C

# CATERPILLAR 977L TRAXCAVATOR

19	4S1509	ELBOW	2
20	1P3301	TUBE ASSEM.	1
21	3R3976	ELBOW	1
22	4B5271	WASHER	2
23	1D4717	NUT	2
24	2P7998	CLIP ASSEM.	1
25	1S3618	CLIP	2
26	5K6806	TUBE ASSEM.	1
27	7K1181	TIE	5
28	4J5267	SEAL	2
29	6K6850	TUBE ASSEM.	1
30	1L1351	BOLT	3

REF. NO.	PART NUMBER	DESCRIPTION	QTY.
1	4J8997	SEAL	4
2	2B947	BOLT	2
3	3B4508	LOCKWASHER	4
4	5L587	BOLT	2
5	5K6819	TUBE ASSEM.	1
6	5S4760	BRACKET	1
7	9L945	"U" BOLT	2
8	1B4330	NUT	4
9	3B4504	LOCKWASHER	4
10	4B5269	WASHER	4
11	5L591	BOLT	8
12	3B4506	LOCKWASHER	16
13	10 5K6785	TUBE ASSEM.	1
14	11 5L594	BOLT	5
15	12 4B4278	WASHER	5
16	13 2S4762	CLIP	2
17	14 1P4576	FLANGE	4
18	15 5L588	BOLT	4
19	16 2P7575	HOSE ASSEM. --(100" long overall)--	8
20	17 5K9660	CLIP	2
21	18 1P2056	SUPPORT	1

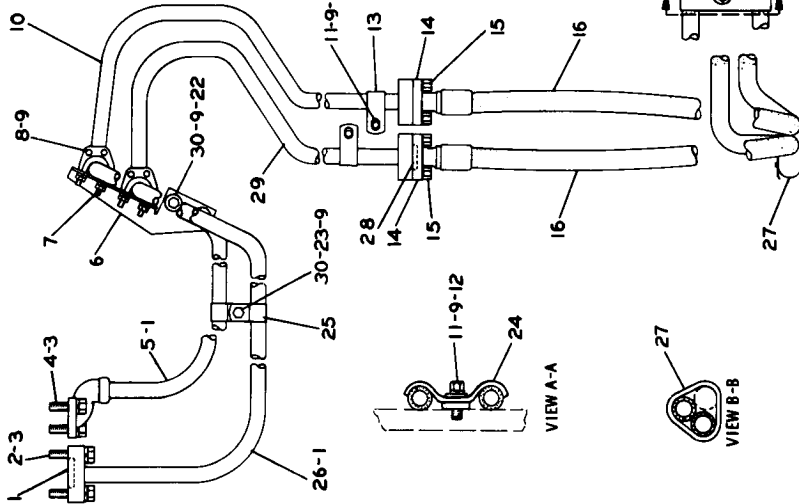

HYDRAULIC OIL COOLER LINES (1P3719 N/S)—As Viewed from R.H. Side of Machine  
 Serial No. 11K5051 to 11K6042 and 11K6261 to 11K6447 inclusive

HYDRAULIC OIL COOLER LINES (1P3719 N/S)—As Viewed from R.H. Side of Machine  
 Serial No. 11K6448—Up

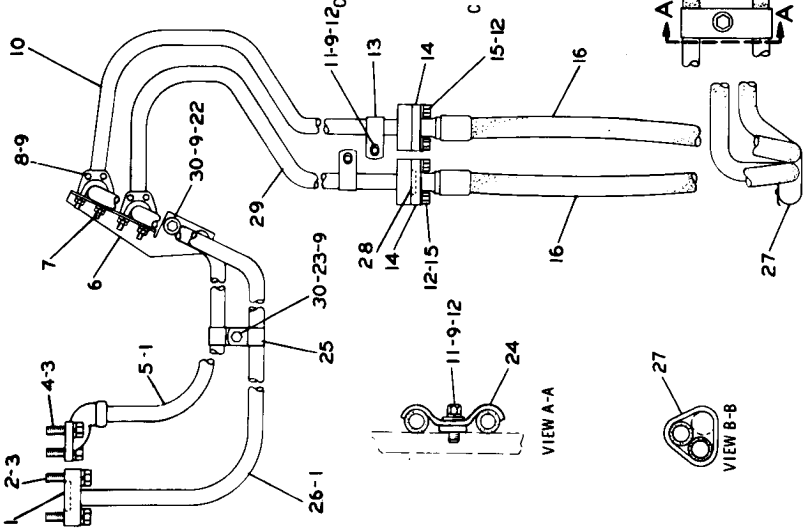

REF. NO.	PART NUMBER	DESCRIPTION	QTY.
1	4J8997	SEAL	4
2	2B947	BOLT	2
3	3B4508	LOCKWASHER	4
4	51587	BOLT	4
5	5K6819	TUBE ASSEM.	2
6	5S4760	BRACKET	1
	9L945	"U" BOLT	1
7	184330	NUT	4
	3B4504	LOCKWASHER	4
	4B5269	WASHER	4
8	51591	BOLT	8
9	3B4506	LOCKWASHER	16
10	5K6785	TUBE ASSEM.	1
11	51594	BOLT	1
12	4B4278	WASHER	13
13	2S4762	CLIP	2
14	1P4576	FLANGE	4
15	51588	BOLT	4
16	2P7575	HOSE ASSEM. --(100" long overall)--	8
17	5K9660	CLIP	2
18	1P2056	SUPPORT	1
19	307930	ELBOW	1
20	1P3301	TUBE ASSEM.	1
21	3R3976	ELBOW	1
22	4B5271	WASHER	2

23	1D4717	NUT	2
24	2P7998	CLIP ASSEM.	1
25	1S3618	CLIP	2
26	5K6806	TUBE	1
27	7K1181	TIE	5
28	4J5267	SEAL	2
29	6K6850	TUBE ASSEM.	1
30	L1351	ROST	3
31	3D2824	SEAL	2
32	5P3411	ELBOW	1

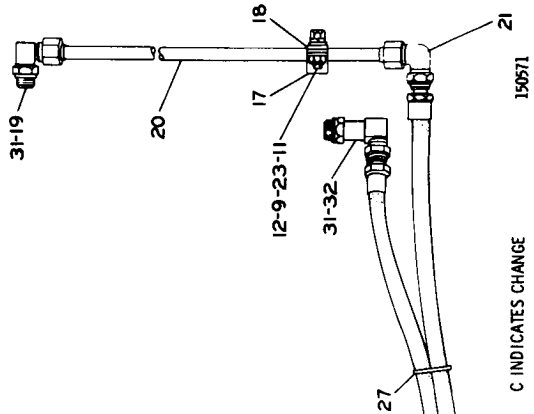

C INDICATES CHANGE

150571

HYDRAULIC OIL COOLER LINES (1P3719 N/S)—As Viewed from R.H. Side of Machine  
 Serial No. 11K6043 to 11K6280 inclusive

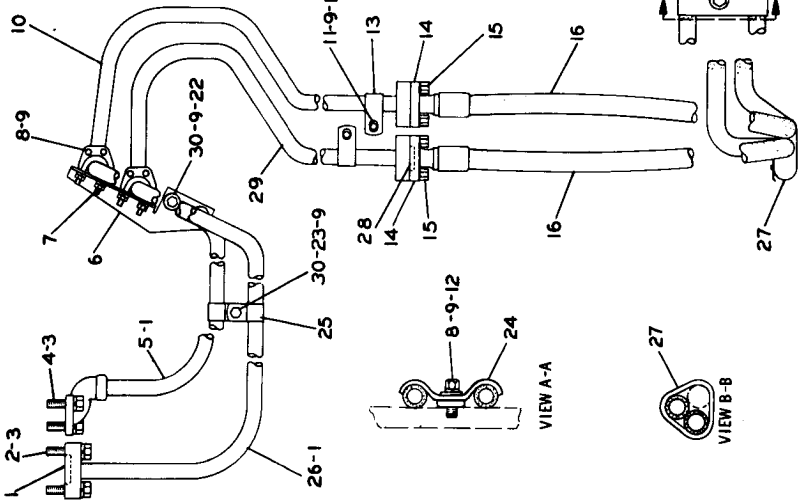

REF. NO.	PART NUMBER	DESCRIPTION	QTY
1	4J8997	SEAL	4
2	2B947	BOLT	2
3	3B4508	LOCKWASHER	4
4	51587	BOLT	2
5	5K6819	TUBE ASSEM.	1
6	5S4760	BRACKET	1
7	9L945	"U" BOLT	2
8	1B4330	NUT	4
9	3B4504	LOCKWASHER	4
10	4B5269	WASHER	4
11	51591	BOLT	10
12	3B4506	LOCKWASHER	16
13	5K6785	TUBE ASSEM.	1
14	51594	BOLT	3
15	4B4278	WASHER	13
16	2S4762	CLIP	2
17	1P4576	FLANGE	4
18	51588	BOLT	2
19	2P1755	HOSE ASSEM. --100 in. (25.4m)	8
20	5K9660	CLIP	2
21	1P2056	SUPPORT	1
22	4S1509	ELBOW	1
23	1P3301	TUBE ASSEM.	1

24	3R3976	ELBOW	1
25	4B5271	WASHER	2
26	1D4717	NUT	2
27	2P7998	CLIP ASSEM.	1
28	1S3618	CLIP	1
29	5K6806	TUBE ASSEM.	2
30	7K1181	TIE	5
31	4J5267	SEAL	2
32	6K6850	TUBE ASSEM.	1
33	1L351	BOLT	3
34	3R9704	ELBOW	1
35	2R6276	CONNECTOR	3

C INDICATES CHANGE

149593

18	S1589	BOLT	6
	3B4510	LOCKWASHER	6
19	8M5258	SEAL	1
20	6K3992	TUBE ASSEM.	1
21	S1585	BOLT	8
22	8J2382	PUMP GROUP (Separate Illustration)	1
23	2H6184	SEAL	1
24	6K1739	TUBE ASSEM.	1
25	5K5225	HOSE	1
C26	5P598	CLAMP	2

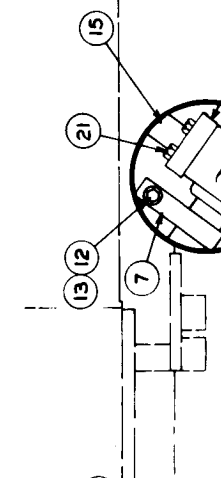

12	1A2079	BOLT	1
13	104717	NUT	1
14	384506	LOCKWASHER	1
15	484278	WASHER	2
16	2P2101	HOSE ASSEM. -92.45 cm(36.40 in.)	1
17	5P183	STEM ASSEM. - (straight)	1
	359333	SLEEVE	2
	358330	STEM ASSEM. -90°	1
	359339	STEM ASSEM. -90°	1

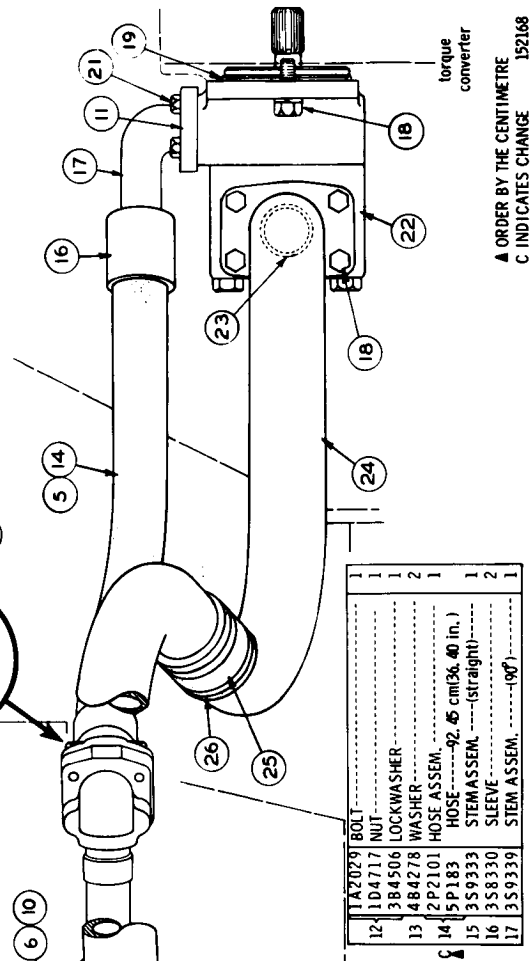

REF. NO.	PART NUMBER	DESCRIPTION	QTY
1	6J2515	BOLT	4
2	384508	LOCKWASHER	6
3	5H8848	SEAL	1
4	951366	BOLT	2
5	6J3650	SEAL	2
6	7K8875	TUBE ASSEM.	1
7	9M5641	CLAMP	1
8	9S8010	PLUG	1
9	Z54078	SEAL	1
10	954191	PLUG	1
11	3J1907	SEAL	1
12	854075	SEAL	1
13	1P4579	FLANGE	4

▲ ORDER BY THE CENTIMETRE 152168  
C INDICATES CHANGE

HYDRAULIC PUMP AND LINES (6K1993 N/S)—As Viewed from R.H. Side of Machine  
Serial No. 11K5051 to 11K5875 inclusive  
8J2382 Pump parts are shown on Page 181

HYDRAULIC PUMP AND LINES (6K1993 N/S)—As Viewed from R.H. Side of Machine  
 Serial No. 11K5876 to 11K6136 inclusive  
 9J399 Pump parts are shown on Page 181

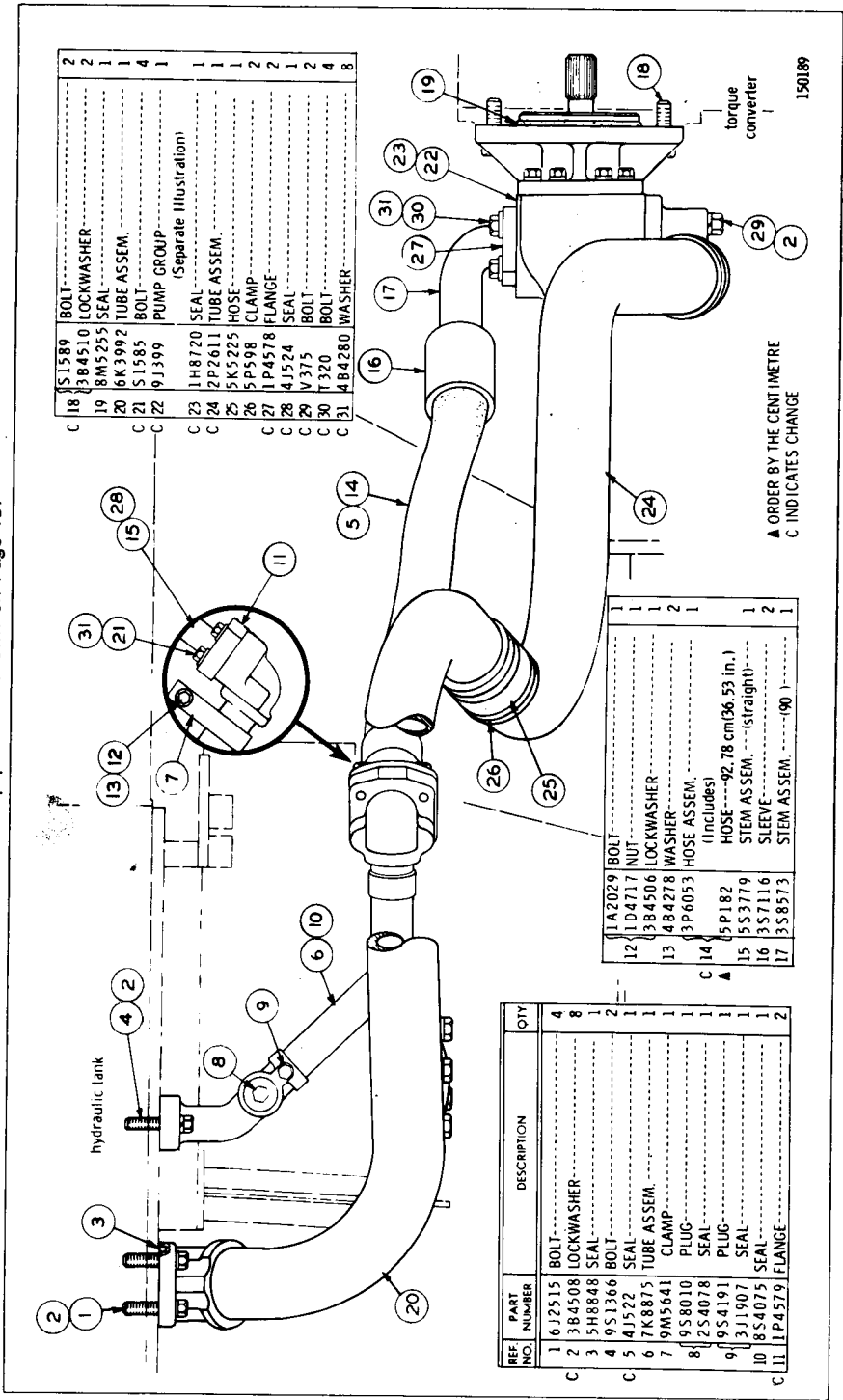

C 18	S 1589	BOLT	2
19	3B4510	LOCKWASHER	2
20	8M5255	SEAL	1
21	6K3992	TUBE ASSEM.	1
C 21	S 1585	BOLT	4
C 22	9J399	PUMP GROUP (Separate Illustration)	1
C 23	1H8720	SEAL	1
C 24	2P2611	TUBE ASSEM.	1
25	5K5225	HOSE	1
26	P598	CLAMP	2
C 27	1P4578	FLANGE	2
C 28	4J524	SEAL	1
C 29	V375	BOLT	2
C 30	T320	BOLT	4
C 31	4B4280	WASHER	8

1	1A2029	BOLT	1
12	1D4717	NUT	1
13	3B4506	LOCKWASHER	1
13	4B4278	WASHER	2
C 14	3P6053	HOSE ASSEM. (Includes) HOSE---92.78 cm(36.53 in.) STEM ASSEM.---(straight) SLEEVE STEM ASSEM.---(90°)	1 1 1 1 1 1 1 1
15	5P182	HOSE	1
15	5S3779	STEM ASSEM.	1
16	3S7116	SLEEVE	2
17	3S8573	STEM ASSEM.	1

REF. NO.	PART NUMBER	DESCRIPTION	QTY
1	1612515	BOLT	4
C 2	3B4508	LOCKWASHER	8
3	5H8848	SEAL	1
4	9S1366	BOLT	2
C 5	4I522	SEAL	1
6	7K8875	TUBE ASSEM.	1
7	9M5641	CLAMP	1
8	2S4078	SEAL	1
9	9S4191	PLUG	1
10	3J1907	SEAL	1
10	8S4075	SEAL	1
C 11	1P4579	FLANGE	2

▲ ORDER BY THE CENTIMETRE  
 C INDICATES CHANGE

150189

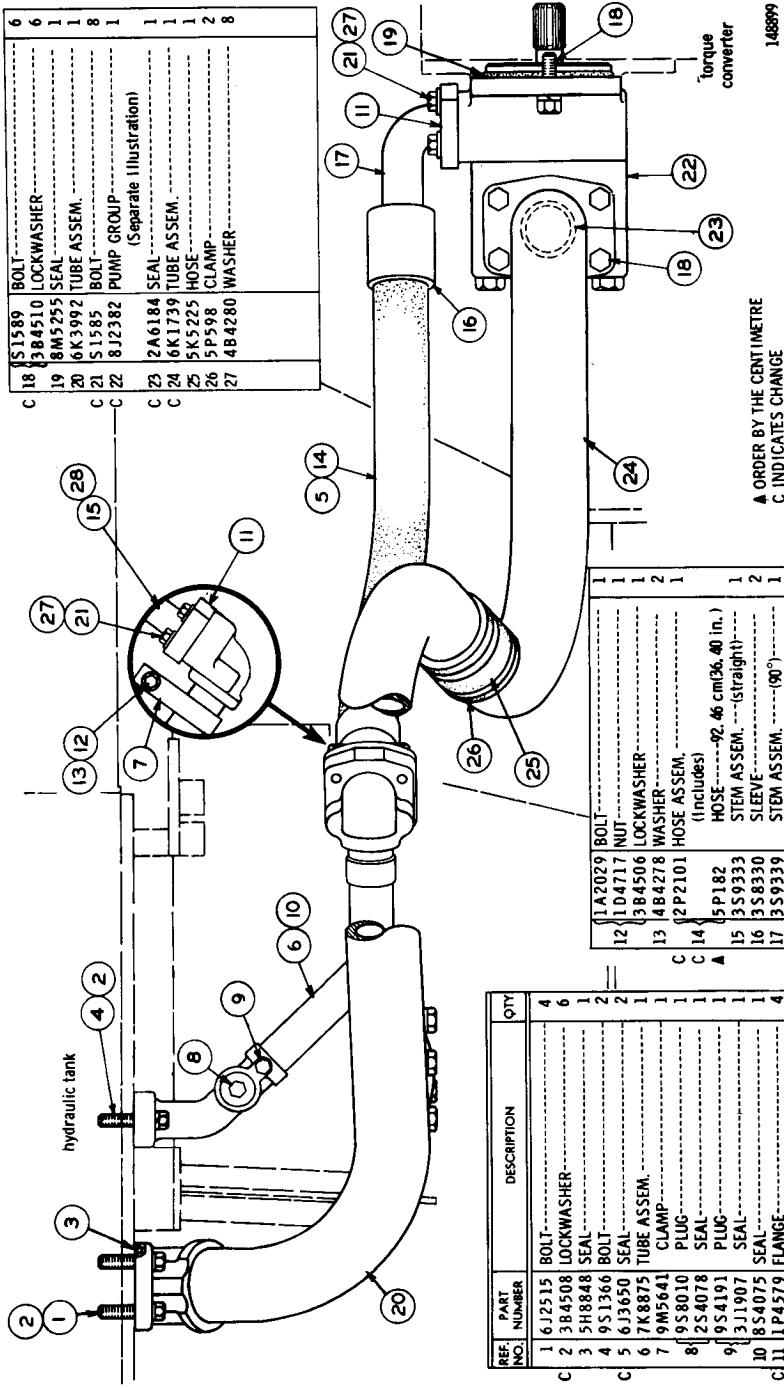

6	S1589	BOLT	6
6	3B4510	LOCKWASHER	1
1	8M5255	SEAL	1
1	6K3992	TUBE ASSEM.	1
8	S1585	BOLT	8
1	8J2382	PUMP GROUP (separate illustration)	1
1	2A6184	SEAL	1
1	6K1739	TUBE ASSEM.	1
1	5K5225	HOSE	1
2	5P598	CLAMP	2
8	4B4280	WASHER	8

1	1A2029	BOLT	1
1	1D4717	NUT	1
1	3B4506	LOCKWASHER	1
2	4B4278	WASHER	2
1	2P2101	HOSE ASSEM. (includes) HOSE-----92.46 cm(36.40 in.) STEM ASSEM.---(straight)--- SLEEVE----- STEM ASSEM.---(90°)	1
1	5P182	HOSE	1
2	3S9333	STEM ASSEM.	2
2	3S8330	SLEEVE	2
1	3S9339	STEM ASSEM.	1

REF. NO.	PART NUMBER	DESCRIPTION	QTY
1	6J2515	BOLT	4
2	3B4508	LOCKWASHER	6
3	5H8848	SEAL	1
4	9S1366	BOLT	2
5	6J3650	SEAL	2
6	7K8875	TUBE ASSEM.	1
7	9M5641	CLAMP	1
8	9S8010	PLUG	1
9	2S4078	PLUG	1
9	9S4191	PLUG	1
9	3J1907	SEAL	1
10	8S4075	SEAL	1
11	1P4579	FLANGE	4

▲ ORDER BY THE CENTIMETRE  
C INDICATES CHANGE

148899

HYDRAULIC PUMP AND LINES (6K1993 N/S)—As Viewed from R.H. Side of Machine  
Serial No. 11K6137—Up  
8J2382 Pump parts are shown on Page 181

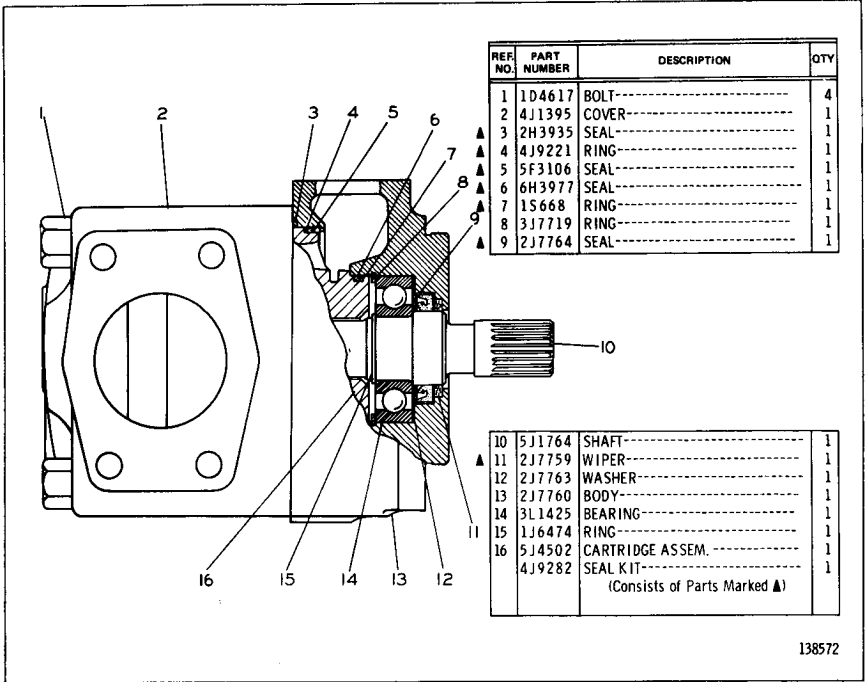

138572

**8J2382 VANE PUMP GROUP**  
 Serial No. 11K5051 to 11K5875 and 11K6137—Up  
 Part of Hydraulic Pump and Lines

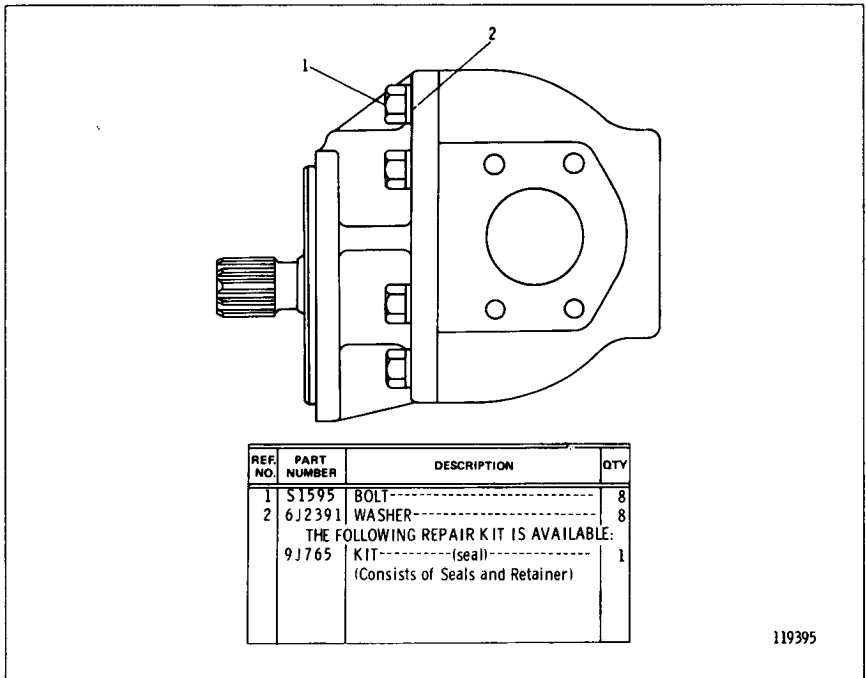

119395

**9J399 GEAR PUMP GROUP**  
 Part of 6K1993 Hydraulic Pump and Lines and 3P5681 Gear  
 Pump Group shown on Pages 180A and 182



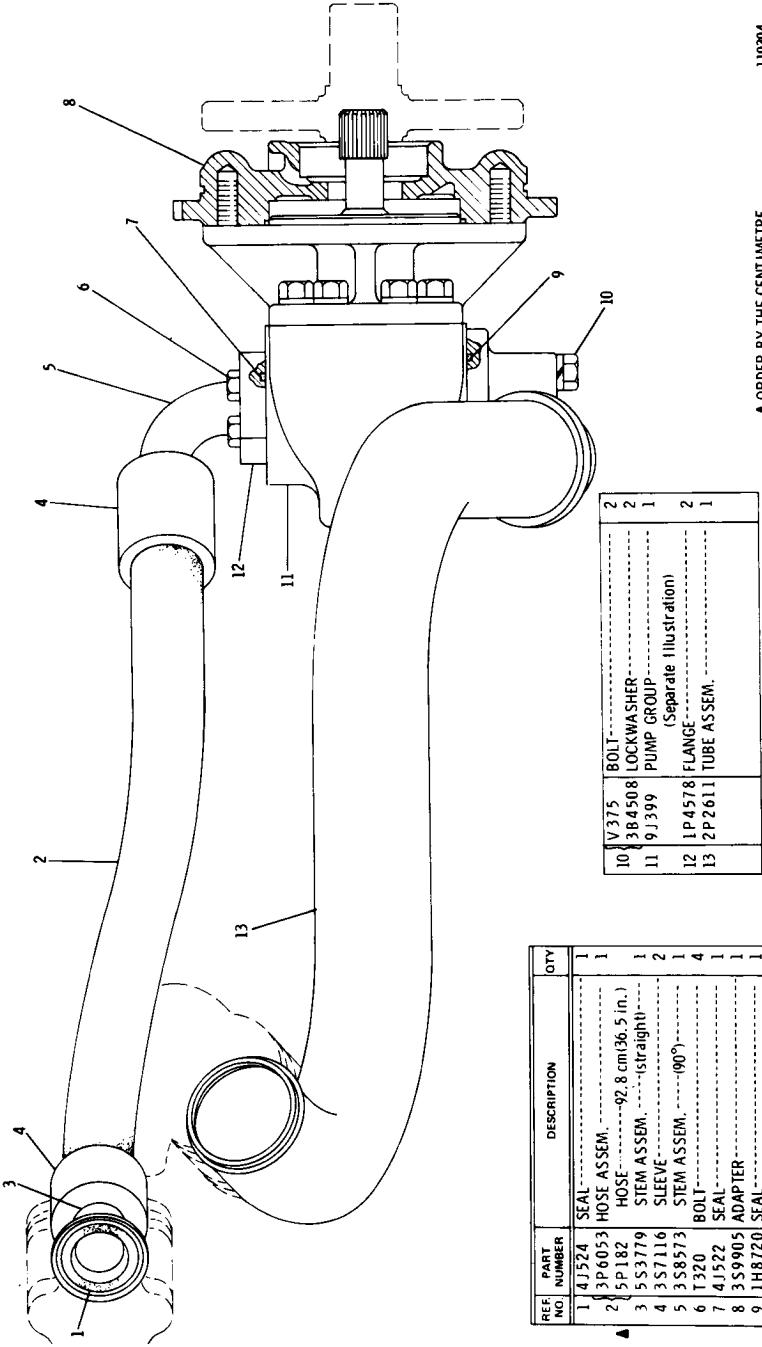

11994

▲ ORDER BY THE CENTIMETRE

REF. NO.	PART NUMBER	DESCRIPTION	QTY.
1	4J524	SEAL	1
2	3P6053	HOSE ASSEM.	1
3	5P182	HOSE-----92.8 cm(36.5 in.)	1
4	5S3779	STEM ASSEM.-----straight	2
5	3S7116	SLEEVE	1
5	3S8573	STEM ASSEM.-----90°	1
6	T320	BOLT	4
7	4J522	SEAL	1
8	3S9905	ADAPTER	1
9	1H8720	SEAL	1

10	V375	BOLT	2
10	3B4508	LOCKWASHER	2
11	9J399	PUMP GROUP	1
11		PUMP GROUP (Separate Illustration)	1
12	1P4578	FLANGE	2
13	2P2611	TUBE ASSEM.	1

3P5681 GEAR PUMP GROUP  
 Part of 6K5440 Hydraulic Arrangement listed on Page 150  
 9J399 Pump parts are shown on Page 181  
 AN ATTACHMENT

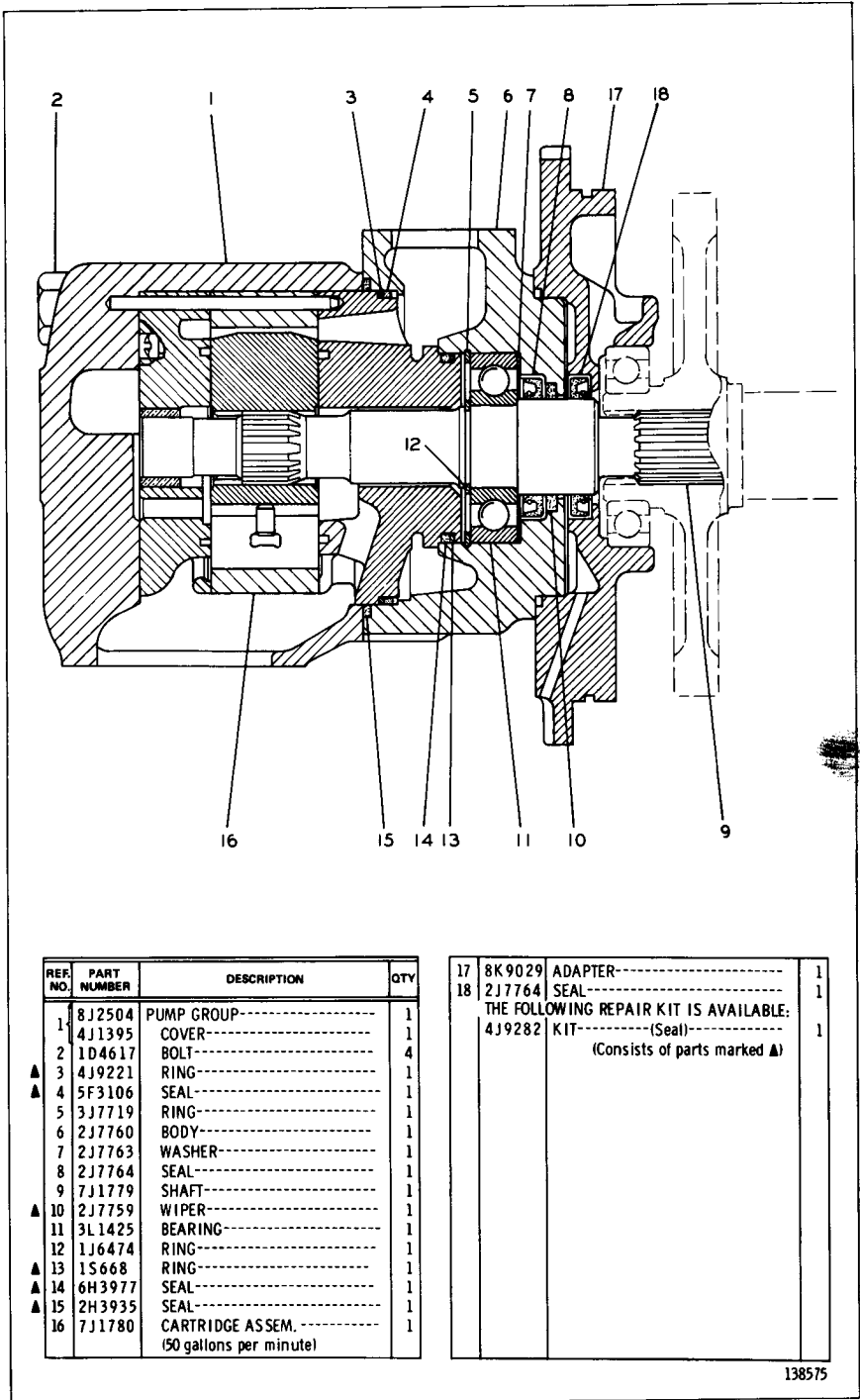

REF. NO.	PART NUMBER	DESCRIPTION	QTY	
	8J2504	PUMP GROUP-----	1	
1	4J1395	COVER-----	1	
2	1D4617	BOLT-----	4	
3	4J9221	RING-----	1	
▲	4	5F3106	SEAL-----	1
5	3J7719	RING-----	1	
6	2J7760	BODY-----	1	
7	2J7763	WASHER-----	1	
8	2J7764	SEAL-----	1	
9	7J1779	SHAFT-----	1	
▲	10	2J7759	WIPER-----	1
11	3L1425	BEARING-----	1	
12	1J6474	RING-----	1	
▲	13	1S668	RING-----	1
▲	14	6H3977	SEAL-----	1
▲	15	2H3935	SEAL-----	1
16	7J1780	CARTRIDGE ASSEM.-----	1	
(50 gallons per minute)				

17	8K9029	ADAPTER-----	1
18	2J7764	SEAL-----	1
THE FOLLOWING REPAIR KIT IS AVAILABLE:			
	4J9282	KIT----- (Seal)	1
(Consists of parts marked ▲)			

138575

9K1094 VANE PUMP GROUP—Water Glycol  
 Part of 6K5440 Hydraulic Arrangement listed on Page 150  
 AN ATTACHMENT

119415

C INDICATES CHANGE

REF. NO.	PART NUMBER	DESCRIPTION	QTY
C 1	7K9184	TUBE ASSEM.	1
C 2	1P4577	FLANGE	2
C 3	6J3600	SEAL	1
C 4	5K9182	TUBE ASSEM.	1
C 5	5K6816	CLIP	1
6	352093	TIE	1
7	3B4508	LOCKWASHER	9
C 8	S1591	BOLT-----1.50" long	10
C 9	L2070	BOLT-----2.25" long	2
C 10	3B4506	LOCKWASHER	16
C 11	S1588	BOLT	4
C 12	4B4278	WASHER	4
13	6K6635	TUBE ASSEM.	1
14	6K620	CLIP	1
14	6K853	CLIP	1

15	12H3855	BOLT	4
16	6K852	LUG	4
16	6H1717	BOLT	4
16	6K819	LUG	1
17	4J8997	SEAL	1
18	6K654	SEAT	1
19	4K4986	SEAL	1
20	5J7691	SWIVEL JOINT GROUP (Separate Illustration)	1
21	6K2124	BOLT	2
22	7K8870	TUBE ASSEM.	1
23	2B947	BOLT	2
24	6K6637	TUBE ASSEM.	1
C 25	1P3703	SEAL	1

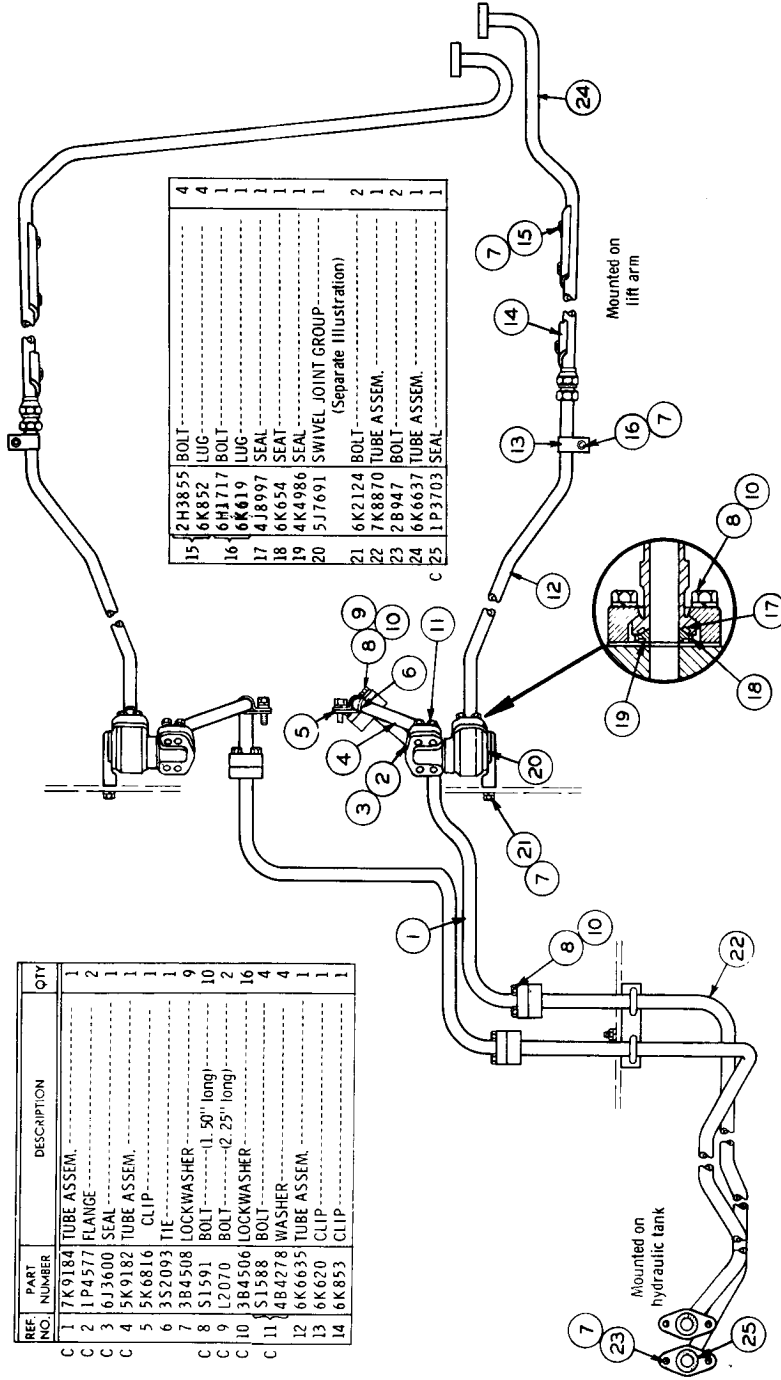

5K6270 FRONT HYDRAULIC LINES GROUP—Part 1  
 Part of 5K6278, 5K6273, 2P8032, 5K6269, 9K4118, 3P7543, 3P7546, 5K9838, 5K9873 and 9K4343 Arrangements listed on Pages 120, 148, 148A, 148D and 149. 5J7691 Joint parts are shown on Page 191

5K6270 FRONT HYDRAULIC LINES GROUP—Part 2  
 Part of 5K6278, 5K6273, 2P8032, 5K6269, 9K4118, 3P7543, 3P7546, 3P7547, 5K9838, 5K9873 and 9K4343 Arrangements  
 listed on Pages 120, 148, 148A, 148D and 149. 5J7692 Joint parts are shown on Page 191

REF. NO.	PART NUMBER	DESCRIPTION	QTY
1	2B947	BOLT	2
2	3B4508	LOCKWASHER	6
3	6J3600	SEAL	1
4	7K8872	TUBE ASSEM.	1
	9L945	"u" BOLT	2
5	1B4330	NUT	4
	3B4504	LOCKWASHER	4
	4B4276	WASHER	4
6	6K4337	BRACKET	4
7	1L1351	BOLT	2
	1D4717	NUT	2
8	3B4506	LOCKWASHER	10
9	5I1591	BOLT	12
10	5K6788	TUBE ASSEM.	1
11	1P3703	SEAL	5
12	5I1595	BOLT	1
13	4B4280	WASHER	1
14	5K6915	TUBE ASSEM.	1
	5K6816	CLIP	1

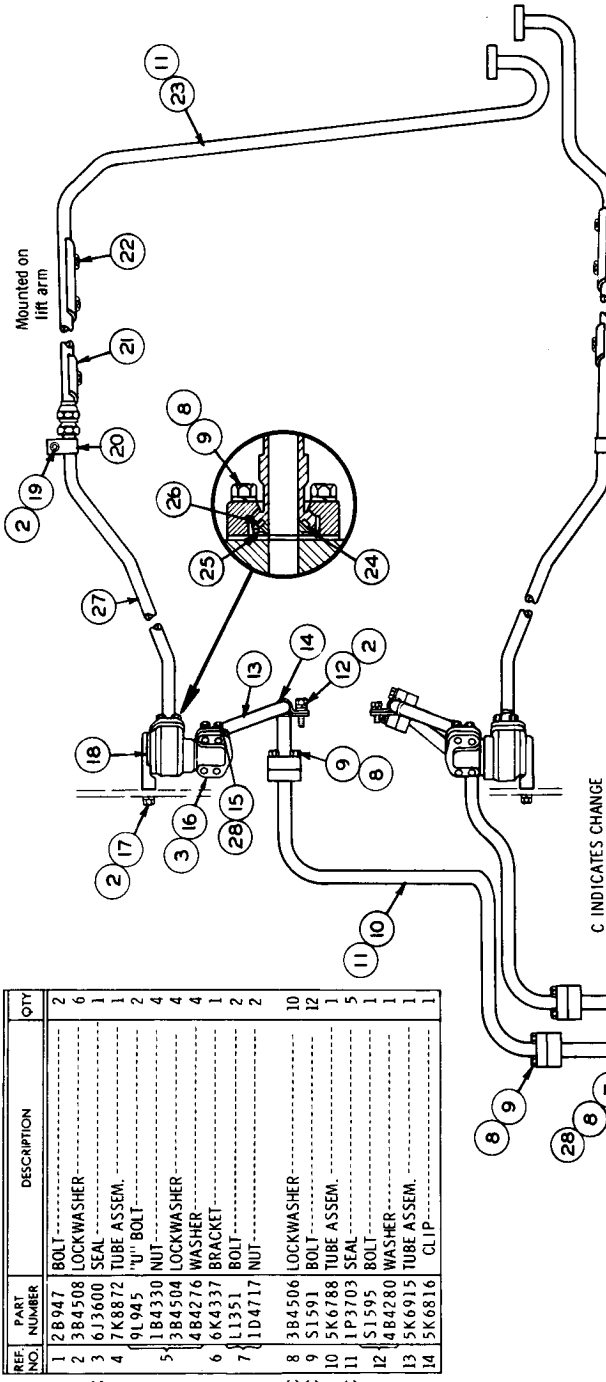

C INDICATES CHANGE

C 15	5I188	BOLT	4
C 16	1P4577	FLANGE	2
C 17	6K2124	BOLT	2
18	5I7692	SWIVEL JOINT GROUP	1
(See Separate Illustration)			
19	6H1717	BOLT	1
20	6K619	CLIP	1
21	6K620	CLIP	1
22	6K853	CLIP	1

23	3B4508	LOCKWASHER	4
24	6K852	LUG	4
25	6K6638	TUBE ASSEM.	1
26	6K654	SEAL	1
27	4K4986	SEAL	1
28	4J8997	SEAL	1
	6K6636	TUBE ASSEM.	1
	4B4278	WASHER	6

119416 C

6K2564 FRONT LINES GROUP—As Viewed from Rear of Machine  
Part of 6K1096 Multi-Purpose Bucket Arrangement listed on Page 202A

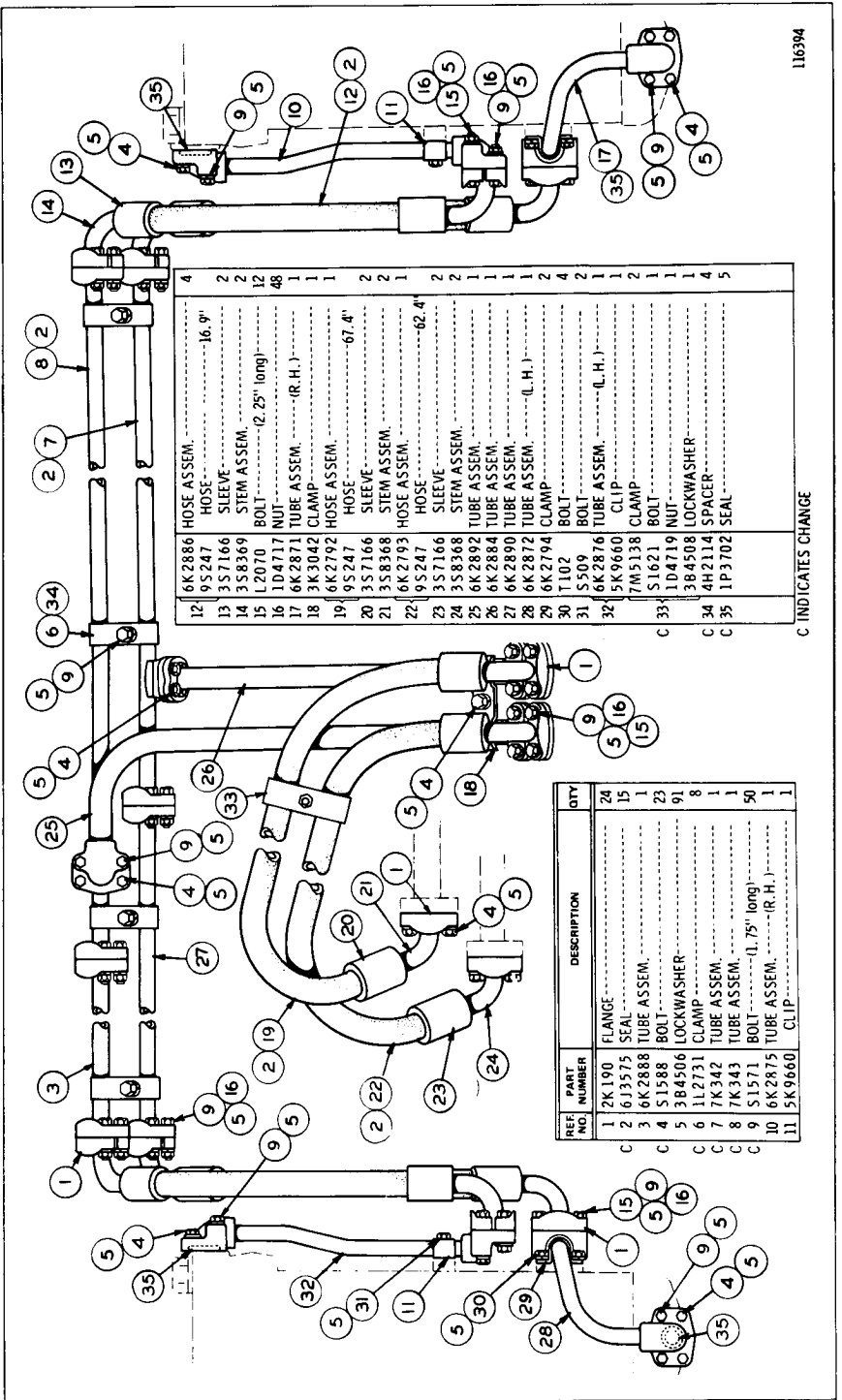

12	6K2886	HOSE ASSEM.	4
13	9S247	HOSE.....16.9"	2
14	3S7166	SLEEVE.....	2
15	3S8389	STEM ASSEM.....(2.29" long)	12
16	1D4717	NUT.....	48
17	6K2871	TUBE ASSEM. ....(R. H.)	1
18	3K3042	CLAMP.....	1
19	6K2792	HOSE ASSEM.	1
20	9S247	HOSE.....67.4"	2
21	3S7166	SLEEVE.....	2
22	6K2793	HOSE ASSEM.	1
23	9S247	HOSE.....62.4"	2
24	3S7166	SLEEVE.....	2
25	3S8388	STEM ASSEM.	2
26	6K2892	TUBE ASSEM.	1
27	6K2884	TUBE ASSEM.	1
28	6K2890	TUBE ASSEM.	1
29	6K2872	TUBE ASSEM. ....(L. H.)	1
30	6K2794	CLAMP.....	2
31	T102	BOLT.....	4
32	S509	BOLT.....(L. H.)	2
33	6K2876	TUBE ASSEM. ....(L. H.)	1
C	5K9660	CLIP.....	2
C	7M5138	CLAMP.....	2
C	S1621	BOLT.....	1
C	1D4719	NUT.....	1
C	3B4508	LOCKWASHER.....	1
C	4H2114	SPACER.....	4
C	1P3702	SEAL.....	5

REF. NO.	PART NUMBER	DESCRIPTION	QTY.
1	2K190	FLANGE.....	24
2	613575	SEAL.....	15
3	6K2888	TUBE ASSEM.	1
4	51588	BOLT.....	23
5	3B4506	LOCKWASHER.....	91
6	1L2731	CLAMP.....	8
7	7K342	TUBE ASSEM. ....(1.75" long)	1
8	7K343	TUBE ASSEM. ....(R. H.)	1
9	51571	BOLT.....	50
10	6K2875	TUBE ASSEM. ....(R. H.)	1
11	5K9660	CLIP.....	1

116194

C INDICATES CHANGE

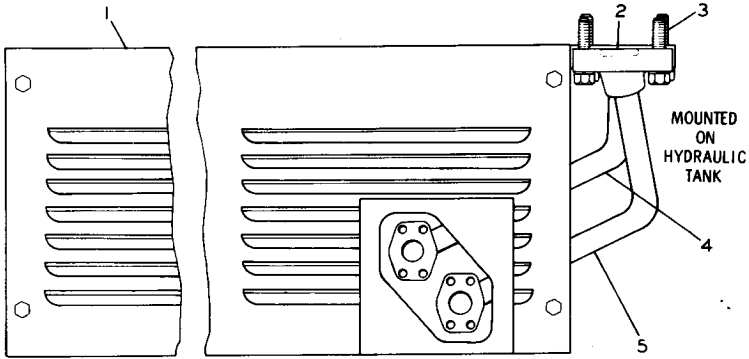

REF. NO.	PART NUMBER	DESCRIPTION	QTY
1	2 P 7991	GUARD ASSEM. -----	1
	3 S 3928	GUARD -----	1
2	1 P 3703	SEAL -----	2
	9 S 1366	BOLT -----	4
3	3 B 4508	LOCKWASHER -----	4

4	2 P 7607	TUBE ASSEM. -----	1
5	2 P 8037	TUBE ASSEM. -----	1
	F M 055046	FORM -----	1
(Instructions for Installing Auxiliary Hydraulic Control Valves)			

C INDICATES CHANGE

144545

2P7607 REAR HYDRAULIC LINES GROUP

Part of 2P8032, 9K4118, 2P8033, 9K4343, 3P7544, 3P7547 and 2P8034 Arrangements listed on Pages 148, 148A, 148B, 148D and 149

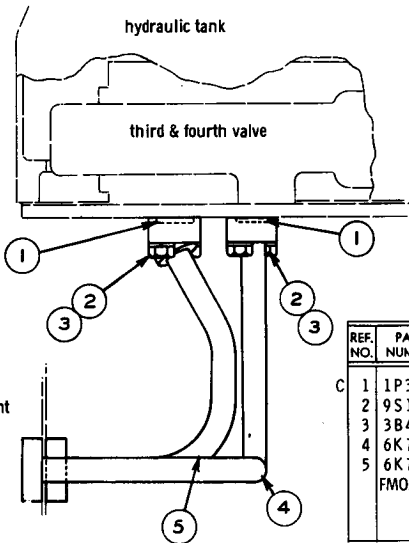

REF. NO.	PART NUMBER	DESCRIPTION	QTY
1	1 P 3703	SEAL -----	2
2	9 S 1366	BOLT -----	4
3	3 B 4508	LOCKWASHER -----	4
4	6 K 7697	TUBE ASSEM. -----	1
5	6 K 7696	TUBE ASSEM. -----	1
	F M 055046	FORM -----	1
(Instructions For Installing Auxiliary Hydraulic Control Valves)			

C INDICATES CHANGE

113924

5K6280 REAR HYDRAULIC LINES GROUP

Part of 5K6278, 5K9839, 3P7545, 3P7546 and 5K9873 Arrangements listed on Pages 148B, 148C, 148D and 149

6K1721 HYDRAULIC LINES GROUP  
 Part of 6K707 Side Dump Bucket Arrangement listed on Page 206  
 AN ATTACHMENT

▲ SOLD BY THE INCH  
 C INDICATES CHANGE

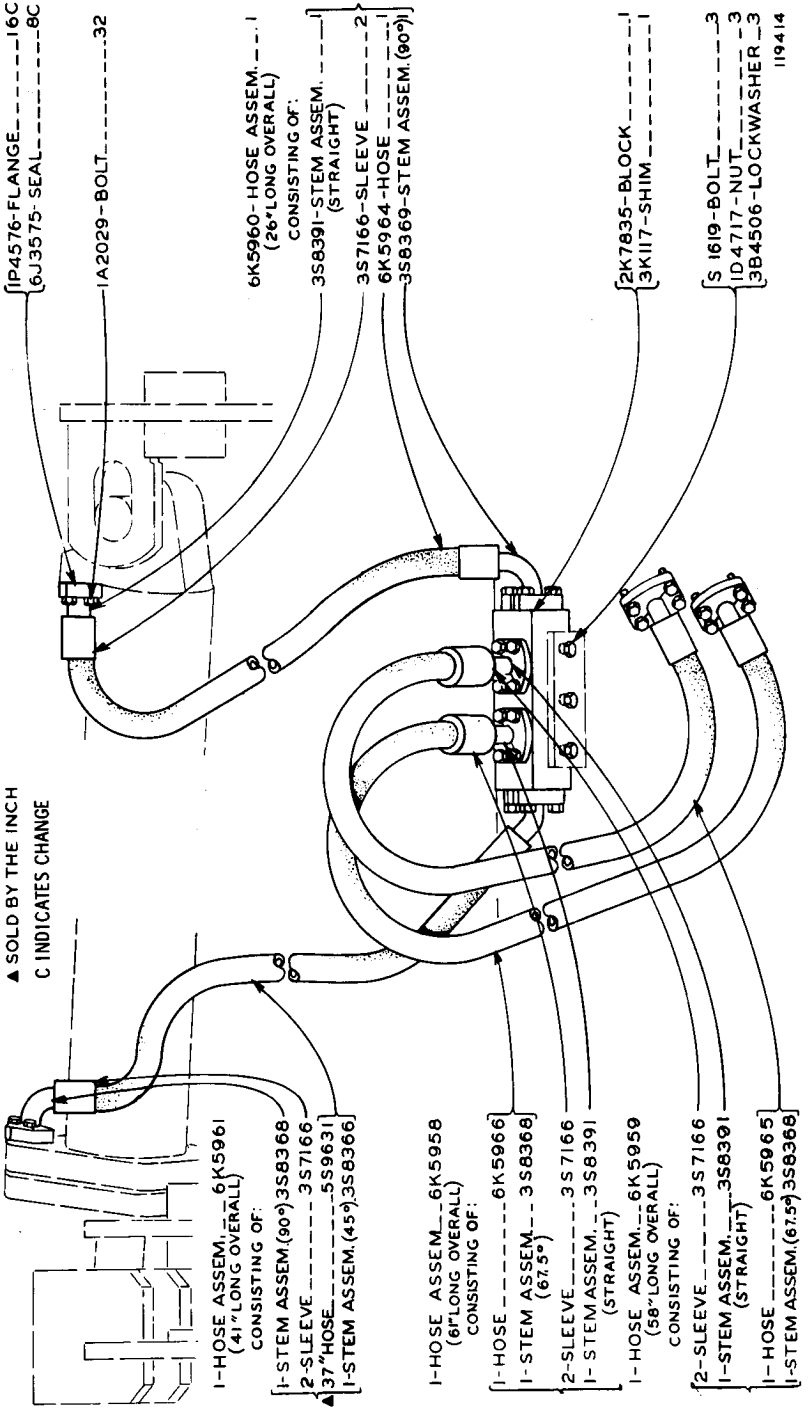

1-HOSE ASSEM.---6K5961  
 (41" LONG OVERALL)  
 CONSISTING OF:

1-STEM ASSEM.(90°)3S8368  
 2-SLEEVE ---3S7166  
 ▲ 37"HOSE ---5S9631  
 1-STEM ASSEM.(45°)3S8366

1-HOSE ASSEM.---6K5958  
 (6" LONG OVERALL)  
 CONSISTING OF:

1-HOSE ---6K5966  
 1-STEM ASSEM.---3S8368  
 (67.5°)  
 2-SLEEVE ---3S7166  
 1-STEM ASSEM.---3S8391  
 (STRAIGHT)

1-HOSE ASSEM.---6K5959  
 (58" LONG OVERALL)  
 CONSISTING OF:

2-SLEEVE ---3S7166  
 1-STEM ASSEM.---3S8391  
 (STRAIGHT)  
 1-HOSE ---6K5965  
 1-STEM ASSEM.(67.5°)3S8368

1P4576-FLANGE---16C  
 6J3575-SEAL---8C

1A2029-BOLT---32

6K5960-HOSE ASSEM.---1  
 (26" LONG OVERALL)  
 CONSISTING OF:

3S8391-STEM ASSEM.---1  
 (STRAIGHT)  
 3S7166-SLEEVE ---2  
 6K5964-HOSE ---1  
 3S8369-STEM ASSEM.(90°)

2K7835-BLOCK  
 3K117-SHIM---1

S 1619-BOLT---3  
 ID 4717-NUT---3  
 3B4506-LOCKWASHER---3  
 119414

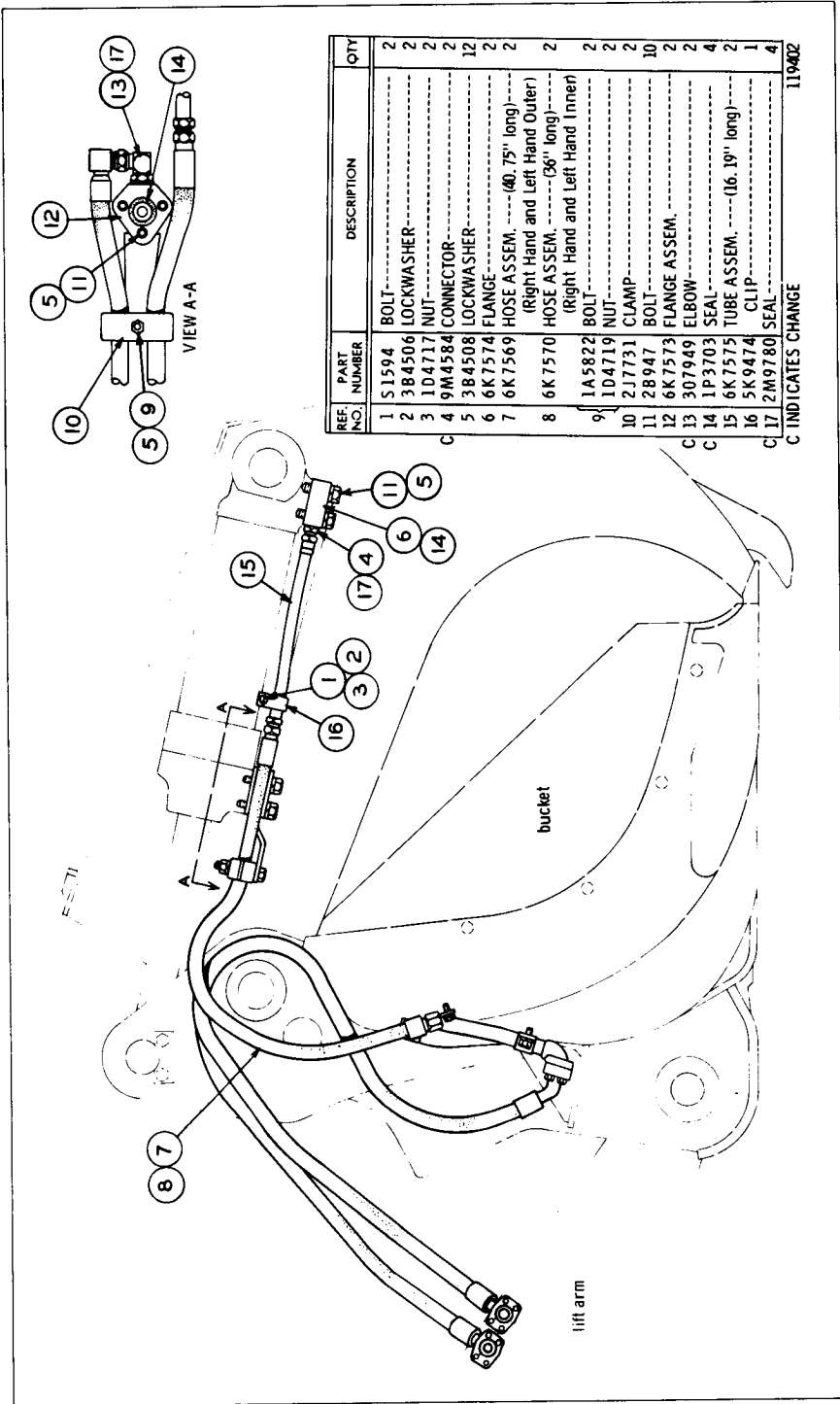

6K7584 HYDRAULIC LINES—As Viewed from R.H. Side of Machine  
 Part of 7K8741 Demolition Bucket Arrangement listed on Page 208  
 AN ATTACHMENT



6K7584 HYDRAULIC LINES GROUP—Top View  
 Part of 7K8741 Demolition Bucket Arrangement listed on Page 208  
 AN ATTACHMENT

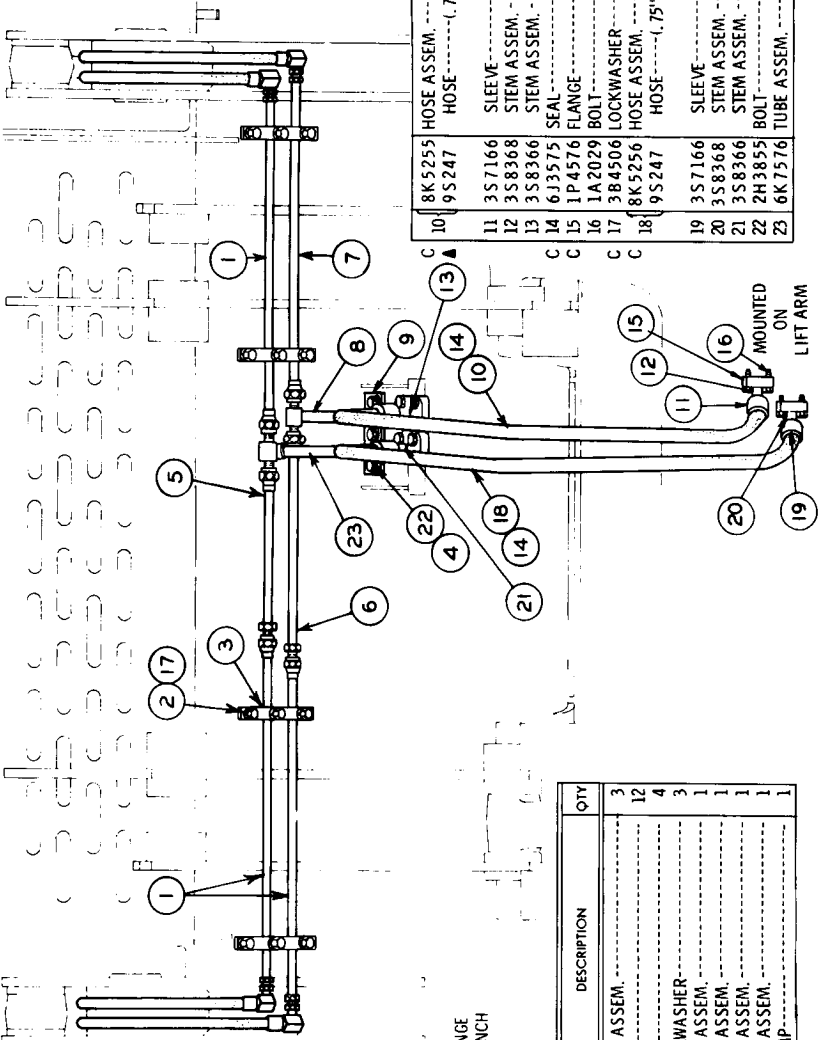

C INDICATES CHANGE  
 ▲ ORDER BY THE INCH

REF NO.	PART NUMBER	DESCRIPTION	QTY
1	6K7566	TUBE ASSEM.	3
2	S1594	BOLT	12
3	6K4234	CLIP	4
4	3B4508	LOCKWASHER	3
5	6K7567	TUBE ASSEM.	1
6	6K7568	TUBE ASSEM.	1
7	6K7565	TUBE ASSEM.	1
8	6K7577	TUBE ASSEM.	1
9	6K7562	CLAMP	1

10	8K5255	HOSE ASSEM.	1
	9S247	HOSE-----(.75" I. D.)---51.4"	
11	3S7166	SLEEVE	2
12	3S8368	STEM ASSEM.---(67.5")	1
13	3S8366	STEM ASSEM.---(45")	1
C 14	6J3575	SEAL	2
C 15	1P4576	FLANGE	8
16	1A2029	BOLT	16
C 17	3B4506	LOCKWASHER	12
	8K5256	HOSE ASSEM.	1
18	9S247	HOSE-----(.75" I. D.)---53.4"	
19	3S7166	SLEEVE	2
20	3S8368	STEM ASSEM.---(67.5")	1
21	3S8366	STEM ASSEM.---(45")	1
22	2H3855	BOLT	3
23	6K7576	TUBE ASSEM.---(11.72" Long)	1

119403

REF. NO.	PART NUMBER	DESCRIPTION	QTY.
1	6K6587	HOSE ASSEM.	2
2	9S247	HOSE-----32.50 in.	1
3	3S8368	STEM ASSEM.------(67.5°)	1
4	3S7166	SLEEVE-----	1
5	3S8369	STEM ASSEM.------(90°)	1
6	6K6583	TUBE ASSEM.	8
7	4K4228	CLAMP	16
8	2H3855	BOLT	16
9	3B4508	LOCKWASHER	60
10	1A2029	BOLT	15
11	6J3575	SEAL	2
12	6K6586	HOSE ASSEM.	2
13	9S247	HOSE-----30.25 in.	2
14	3S7166	SLEEVE	2
15	3S8369	STEM ASSEM.	1
16	3S8391	STEM ASSEM.	1
17	1P4576	FLANGE	24
18	6K6581	TUBE ASSEM.	2
19	6K6590	TUBE ASSEM.	1
20	6K6582	TUBE ASSEM.	1
21	6K6584	HOSE ASSEM.	1
22	9S247	HOSE-----47 in.	1
23	3S8366	STEM ASSEM.------(45°)	1
24	3S7166	SLEEVE	2
25	3S8368	STEM ASSEM.------(67.5°)	1
26	6K6585	HOSE ASSEM.	1
27	9S247	HOSE-----49 in.	1
28	3S8368	STEM ASSEM.------(67.5°)	1
29	3S7166	SLEEVE	2
30	3S8366	STEM ASSEM.------(45°)	1
31	3B4506	LOCKWASHER	12

119421

▲ ORDER BY THE INCH

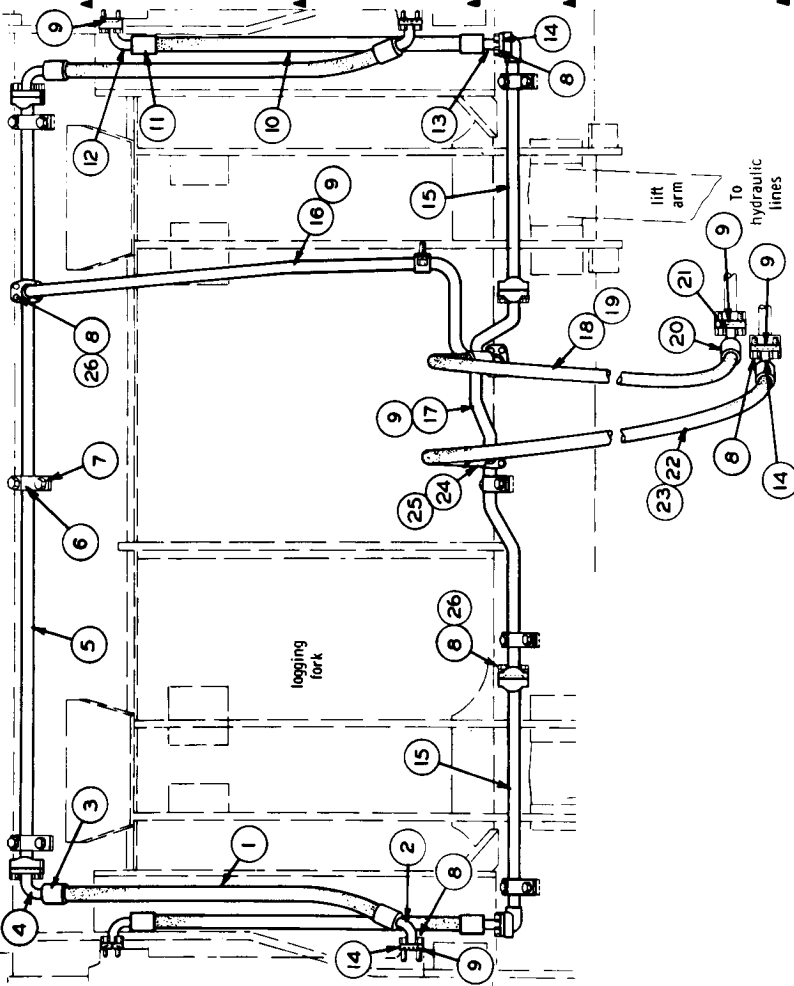

6K6574 HYDRAULIC LINES GROUP  
 Part of 6K1009 Top Clamp Arrangement listed on Page 209  
 AN ATTACHMENT

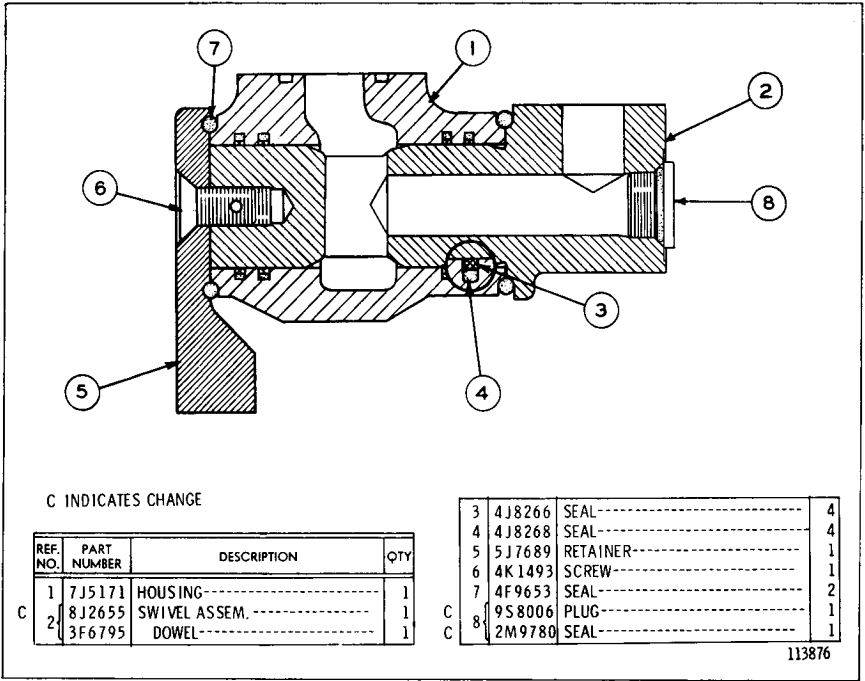

5J7691 SWIVEL JOINT GROUP—R.H.  
Part of 5K6270 Front Hydraulic Lines Group shown on Page 184

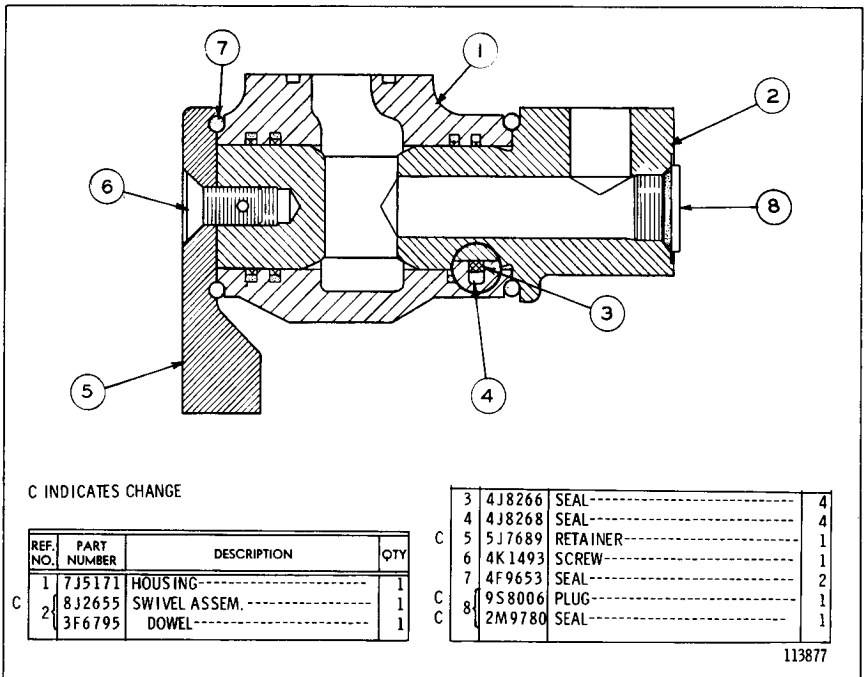

5J7692 SWIVEL JOINT GROUP—L.H.  
Part of 5K6270 Front Hydraulic Lines Group shown on Page 185

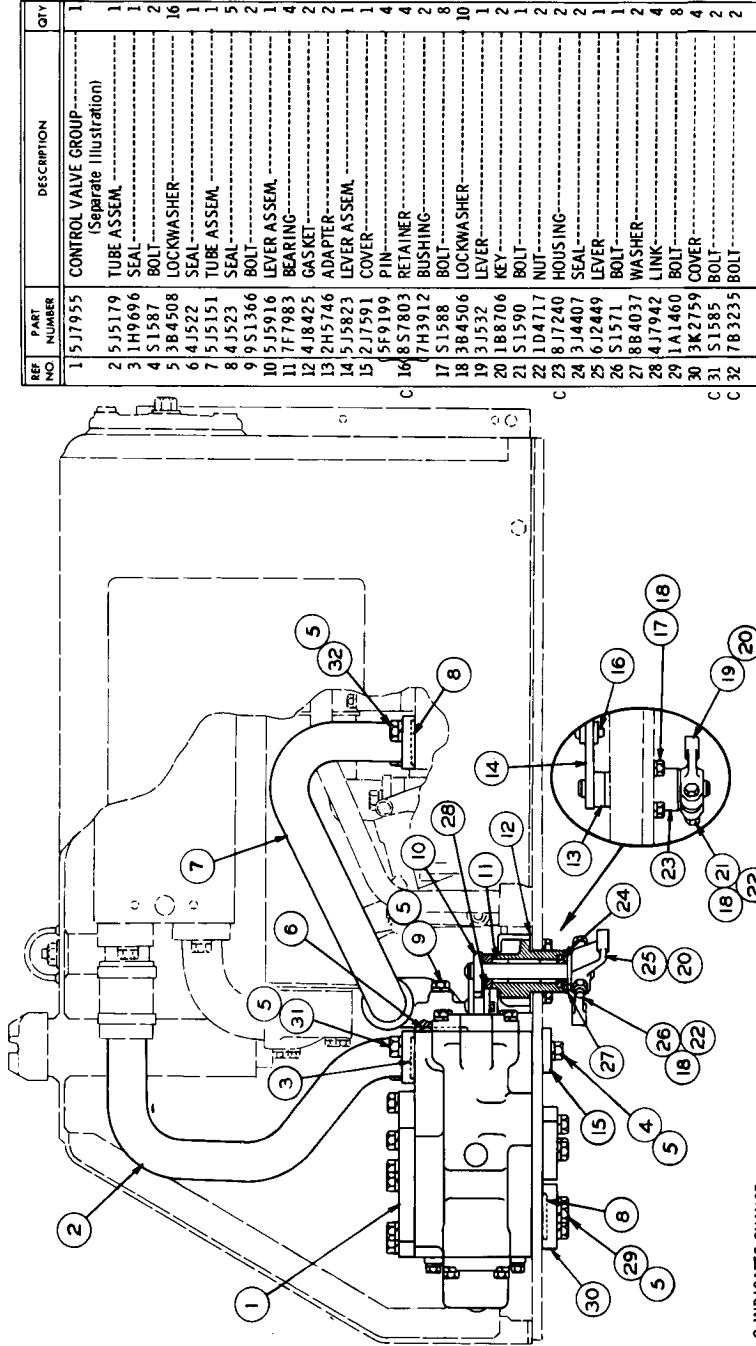

C INDICATES CHANGE

142#95

REF. NO.	PART NUMBER	DESCRIPTION	QTY.
1	5J57955	CONTROL VALVE GROUP (Separate Illustration)	1
2	5J5179	TUBE ASSEM.	1
3	1H9696	SEAL	1
4	51587	BOLT	2
5	3B4508	LOCKWASHER	16
6	4J522	SEAL	1
7	5J5151	TUBE ASSEM.	1
8	4J523	SEAL	5
9	5S1366	BOLT	2
10	5J5916	LEVER ASSEM.	1
11	7F798	BEARING	1
12	4J8425	GASKET	2
13	2H5746	ADAPTER	2
14	5J5823	LEVER ASSEM.	1
15	2J7591	COVER	1
	5F9199	PIN	4
16	8S57803	RETAINER	4
	7H9912	BUSHING	2
17	51588	BOLT	8
18	3B4506	LOCKWASHER	10
19	3J532	LEVER	1
20	1B8706	KEY	2
21	51590	BOLT	1
22	1D4717	NUT	2
23	8J7240	HOUSING	2
24	3J4407	SEAL	2
25	6J2449	LEVER	1
26	51571	BOLT	1
27	8B4037	WASHER	2
28	4J7942	LINK	2
29	1A1460	BOLT	8
30	3K2759	COVER	4
31	51585	BOLT	2
32	7B3235	BOLT	2

5J5723 FIELD CONVERSION GROUP  
 Serial No. 11K5051 to 11K6202 inclusive  
 Part of 5K9839, 5K9838, 5K9873, 9K4343 and 2P8034 Conversion Arrangements listed on Pages 148C and 149  
 5J7955 Valve parts are shown on Page 173

9J635 FIELD CONVERSION GROUP

Serial No. 11K6203—Up

Part of 3P7543, 3P7544 and 3P7547 Conversion Arrangements listed on Page 148D

5J7955 Valve parts are shown on Page 173

REF NO	PART NUMBER	DESCRIPTION	QTY
1	5J7955	CONTROL VALVE GROUP----- (Separate Illustration)	1
2	9J664	TUBE ASSEM.	1
3	1H9696	SEAL	2
4	51587	BOLT	2
5	3B4508	LOCKWASHER	14
6	4J522	SEAL	1
7	5J5151	TUBE ASSEM.	1
8	4J523	SEAL	5
9	9S1366	BOLT	5
10	8J6133	LEVER ASSEM.	1
11	9H8731	BEARING	1
12	4J8425	GASKET	4
13	2H5746	ADAPTER	2
14	8J6132	LEVER ASSEM.	2
15	7B3235	BOLT	2
	5F9199	PIN	4
16	8S7803	RETAINER	4
	7H3912	BUSHING	2
17	51588	BOLT	8
18	3B4506	LOCKWASHER	8
19	3J532	LEVER	1
20	1B8706	KEY	2
21	51590	BOLT	1
22	1D4717	NUT	2
23	8J7240	HOUSING	2
24	3J4407	SEAL	2
25	6J2449	LEVER	1
26	51571	BOLT	1
27	8B4037	WASHER	2
28	4J7942	LINK	4
29	1A1460	BOLT	8
30	3K2759	COVER	4

148918

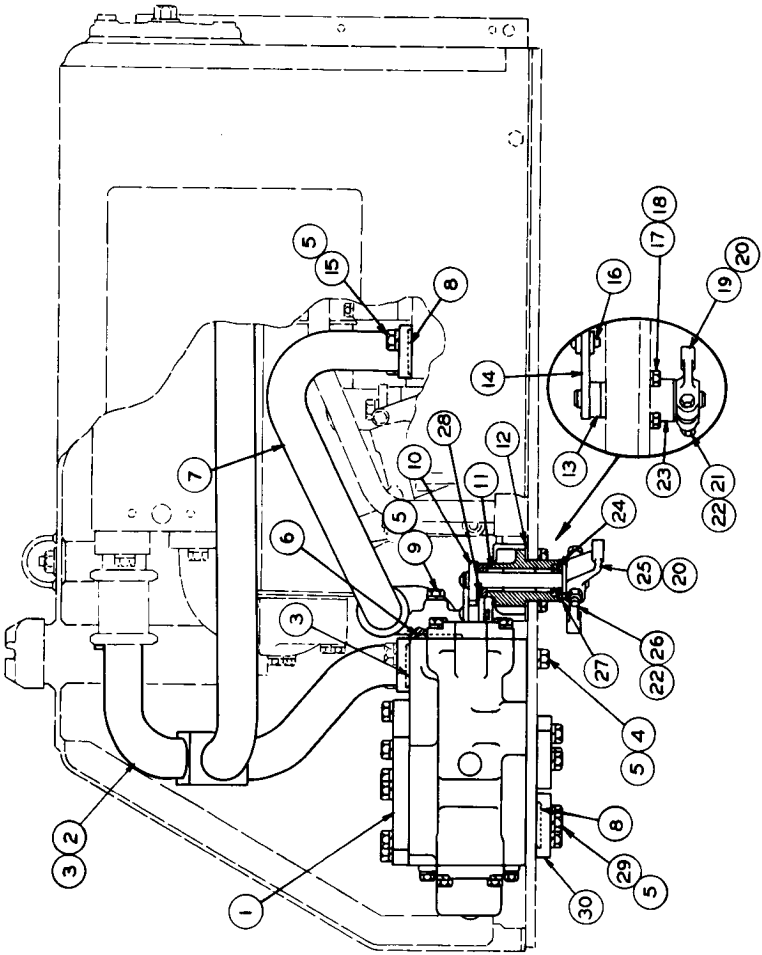

CATERPILLAR 977L TRAXCAVATOR

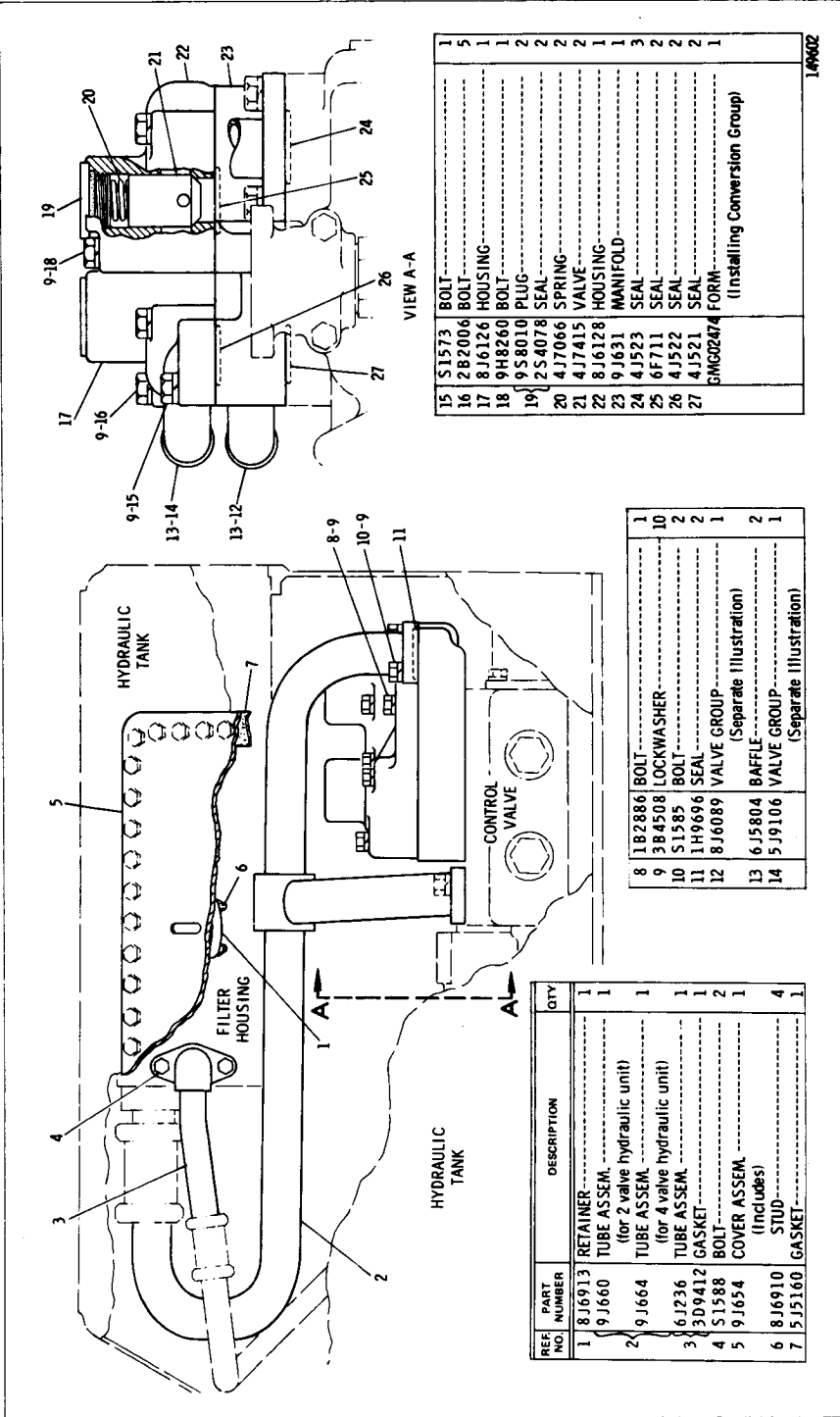

9J4720 FIELD CONVERSION GROUP—Hydraulic Tank and Valve  
 5J9106 and 8J6089 Valve parts are shown on Pages 177 and 178A. Note: Provides parts necessary to convert 5J5722, 6J7041, 5J5724 and 5J5726 Hydraulic Units into 9J642, 9J641, 9J644 and 9J646 Hydraulic Units respectively. These parts provide supercharged and sealed make-up Valve flow to both the rod end of lift cylinders and the head end tilt cylinders

5J5725 FIELD CONVERSION GROUP  
 Serial No. 11K5051 to 11K6202 Inclusive. Part of 6P2277 and 6P2279 Arrangements  
 listed on Page 148F. 5J7963 Valve parts are shown on Page 176

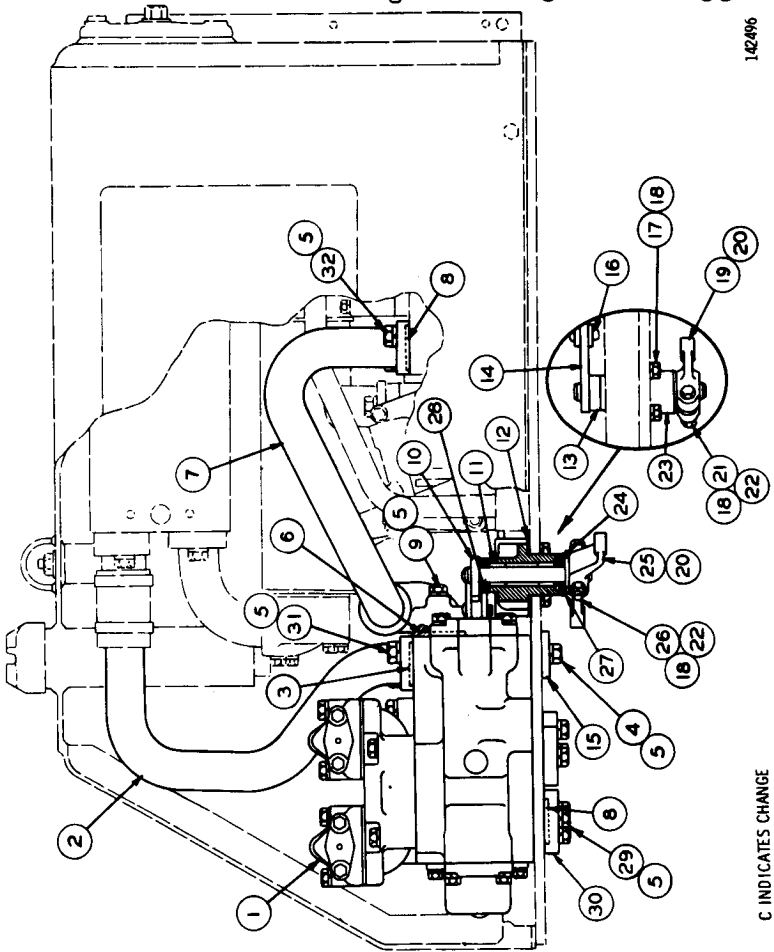

REF NO	PART NUMBER	DESCRIPTION	QTY	
1	15J7963	CONTROL VALVE GROUP (Separate Illustration)	1	
2	5J5179	TUBE ASSEM.	1	
3	1H9696	SEAL	1	
4	51587	BOLT	2	
5	384508	LOCKWASHER	16	
6	4J522	SEAL	1	
7	5J5151	TUBE ASSEM.	1	
8	4J523	SEAL	5	
9	5J366	BOLT	2	
10	5J5916	LEVER ASSEM.	1	
11	7F7983	BEARING	1	
12	4J8425	GAS KEF	4	
13	2H5746	ADAPTER	2	
14	5J5823	LEVER ASSEM.	2	
15	2J7591	COVER	1	
16	5F9199	PIN	1	
17	8S7803	RETAINER	4	
18	7H3912	BUSHING	2	
19	51588	BOLT	8	
20	384506	LOCKWASHER	10	
21	3J532	LEVER	1	
22	1B8706	KEY	2	
23	51590	BOLT	2	
24	1D4717	NUT	2	
25	8J7240	HOUSING	2	
26	3J4407	SEAL	2	
27	6J2449	LEVER	1	
28	51571	BOLT	1	
29	884037	WASHER	2	
30	4J7942	LINK	4	
31	1A1460	BOLT	8	
32	3K2759	COVER	4	
C	31	51585	BOLT	9
C	32	783235	BOLT	2

142496

C INDICATES CHANGE

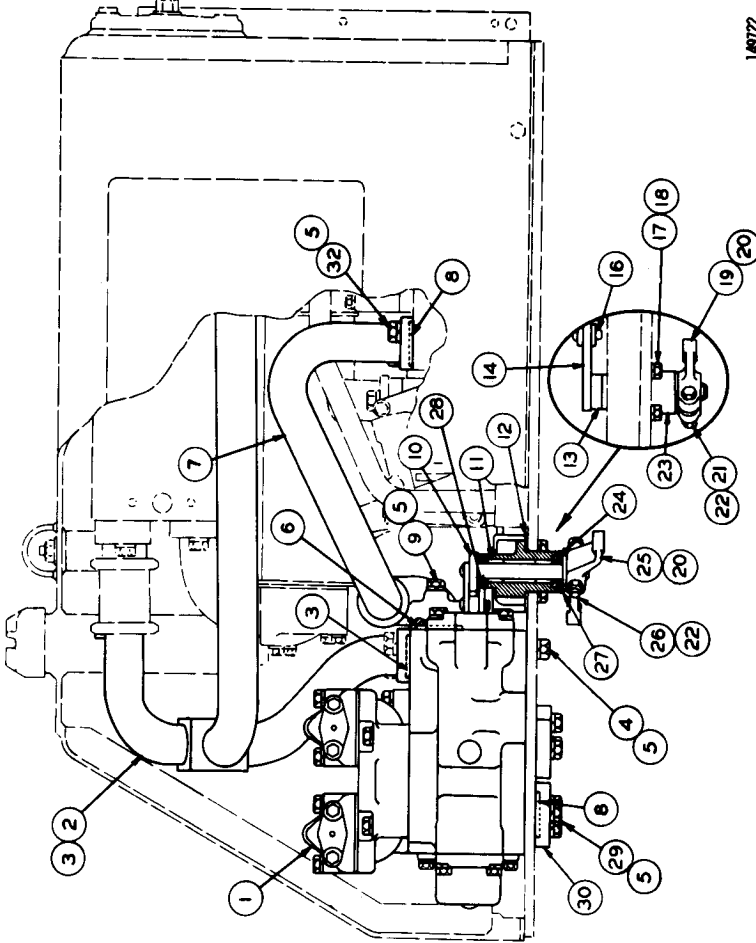

149722

REF NO	PART NUMBER	DESCRIPTION	QTY	
1	5J7963	CONTROL VALVE GROUP (Separate Illustration)	1	
2	9S664	TUBE ASSEM.	1	
3	1H9696	SEAL	2	
4	51587	BOLT	2	
5	384508	LOCKWASHER	14	
6	4J522	SEAL	1	
7	5J5151	TUBE ASSEM.	1	
8	4J523	SEAL	5	
9	9S1366	BOLT	2	
10	8J6133	LEVER ASSEM.	1	
11	9H8751	BEARING	1	
12	4J8425	GASKET	4	
13	2H5746	ADAPTER	2	
14	8J6132	LEVER ASSEM.	1	
	9F9199	PIN	4	
	16B57803	RETAINER	4	
	7H3912	BUSHING	2	
	17	51588	BOLT	8
	18	384506	LOCKWASHER	8
	19	3J532	LEVER	1
	20	188706	KEY	2
	21	51590	NUT	1
	22	1D4717	BOLT	2
	23	8J7240	HOUSING	2
	24	3J4407	SEAL	2
	25	6J2449	LEVER	2
	26	51571	BOLT	1
	27	884037	WASHER	1
	28	4J7942	LINK	4
	29	1A1460	BOLT	4
	30	3K2759	COVER	4
	32	783235	BOLT	2

9J637 FIELD CONVERSION GROUP  
 Serial No. 11K6203—Up. Part of 6P2276 and 6P2278 Field Conversion Arrangements listed on Page 148E  
 5J7963 Valve parts are shown on Page 176



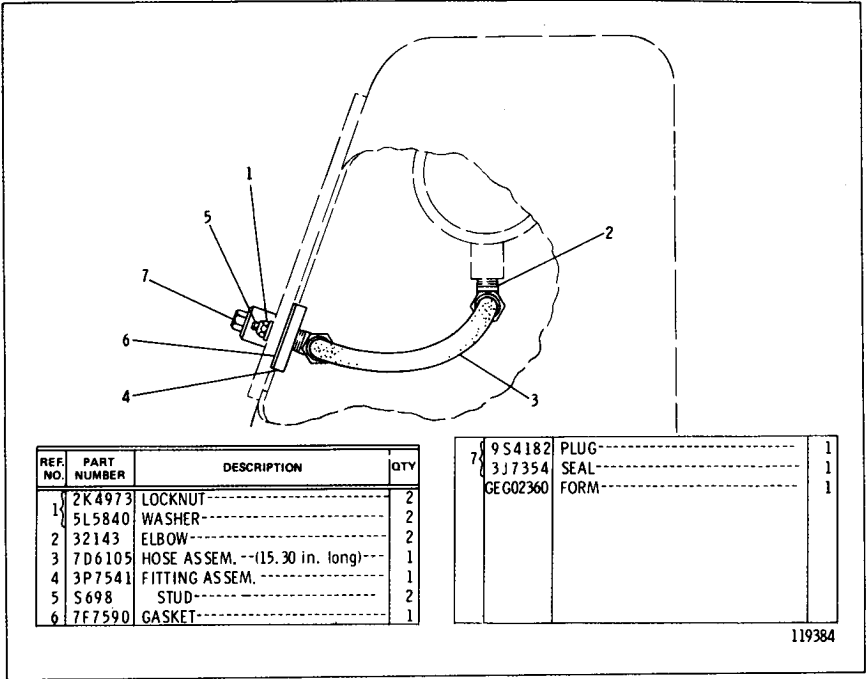

119384

3P7542 HYDRAULIC FILTER DRAIN GROUP—Field Installation  
 Serial No. 11K5051 to 11K5151 inclusive  
 FOR USE WITH ENCLOSED ROLL-OVER PROTECTIVE STRUCTURE

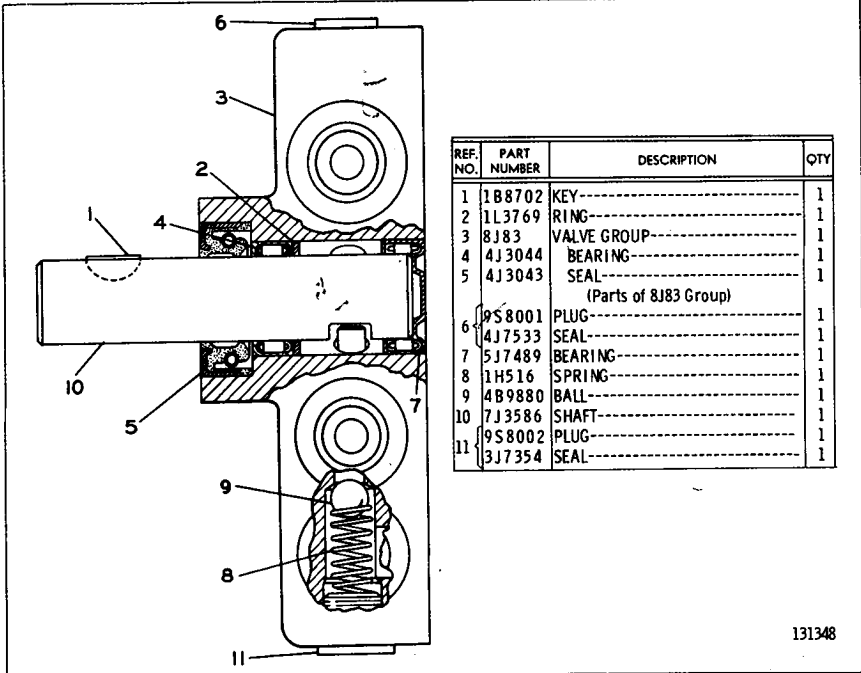

131348

8J82 PILOT VALVE GROUP  
 Part of Bucket Positioner shown on Pages 194 & 195

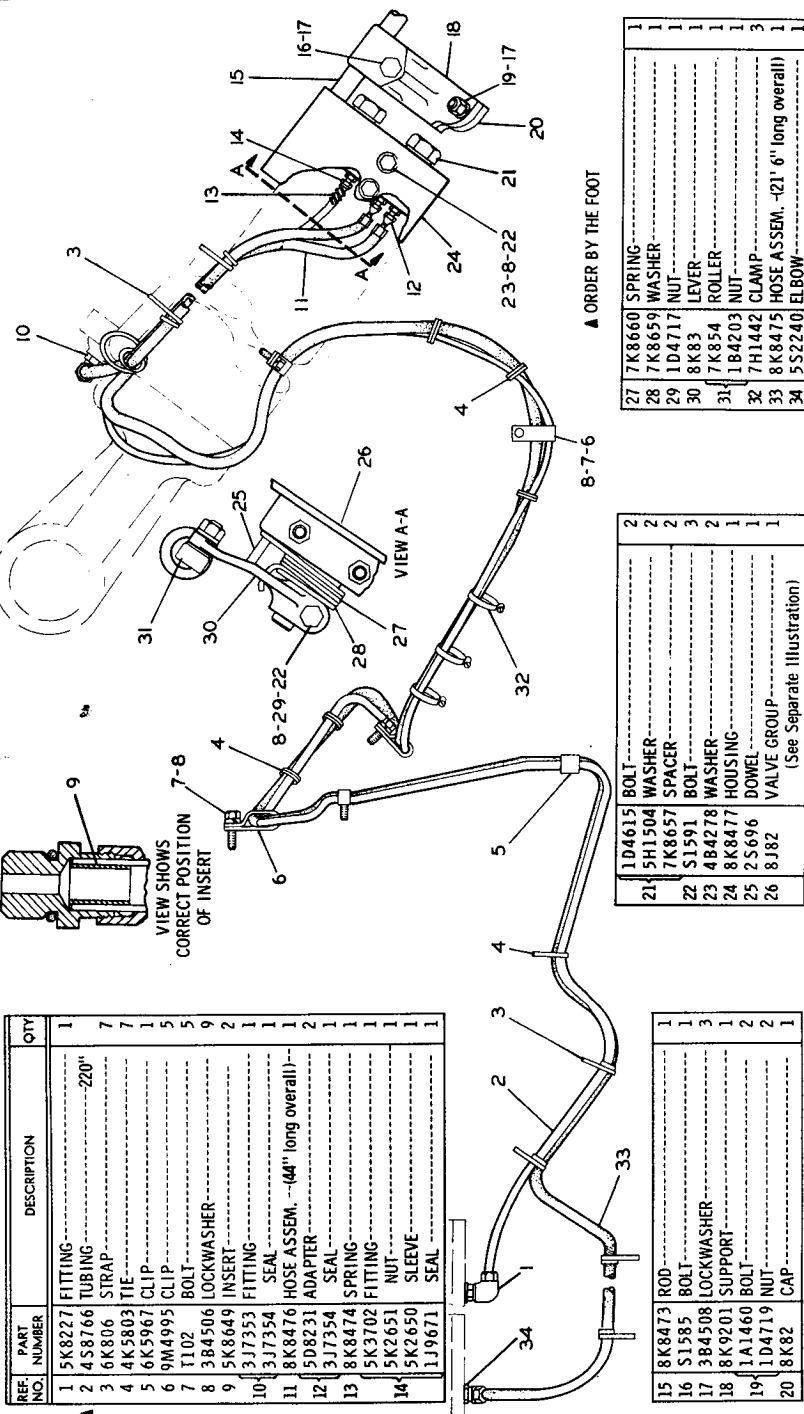

REF. NO.	PART NUMBER	DESCRIPTION	QTY.
1	5K8227	FITTING	1
2	4S8766	TUBING ---220"	1
3	6K806	STRAP	7
4	4K5803	TIE	7
5	6K5967	CLIP	1
6	9M4995	CLIP	5
7	1102	BOLT	9
8	3B4506	LOCKWASHER	5
9	5K8649	INSERT	2
10	3J7353	FITTING	1
11	3J7354	SEAL	1
11	8K8476	HOSE ASSEM. ---(44" long overall)	1
12	5D8231	ADAPTER	2
13	3J7354	SEAL	1
13	8K8474	SPRING	1
13	5K3702	FITTING	1
14	5K2651	NUT	1
14	5K2650	SLEEVE	1
14	1J9671	SEAL	1

15	8K8473	ROD	1
16	S1585	BOLT	1
17	3B4508	LOCKWASHER	3
18	8K9201	SUPPORT	3
19	1A1460	BOLT	2
19	1D4719	NUT	2
20	8K82	CAP	1

21	1D4615	BOLT	2
21	5H1504	WASHER	2
22	7K8657	SPACER	2
22	S1591	BOLT	3
23	4B4278	WASHER	2
24	8K8477	HOUSING	1
25	25696	DOWEL	1
26	8182	VALVE GROUP	1

(See Separate Illustration)

27	7K8660	SPRING	1
28	7K8659	WASHER	1
29	1D4717	NUT	1
30	8K83	LEVER	1
31	7K854	ROLLER	1
31	1B4203	NUT	1
32	7H1442	CLAMP	3
33	8K8475	HOSE ASSEM. ---(21' 6" long overall)	1
34	552240	ELBOW	1

11340A

BUCKET POSITIONER (8K8479 N/S)—As Viewed from Right Hand Side of Machine  
 Serial No. 11K5051 to 11K5096 inclusive  
 8J82 Valve parts are shown on Page 193

BUCKET POSITIONER (8K8479 N/S)—As Viewed from Right Hand Side of Machine  
 Serial No. 11K5097—Up  
 8J82 Valve parts are shown on Page 193

REF. NO.	PART NUMBER	DESCRIPTIC 1	QTY
1	5K8227	FITTING.....	1
2	4S8766	TUBING.....-220"	1
3	6K806	STRAP.....	7
4	4K5803	TIE.....	7
5	6K5967	CLIP.....	1
6	9M4995	CLIP.....	5
7	T102	BOLT.....	5
8	3B4506	LOCKWASHER.....	9
9	5K8649	INSERT.....	2
10	3J7353	FITTING.....	1
	3J7354	SEAL.....	1
11	8K8476	HOSE ASSEM. - (44" long overall) -	1
C 12	3J7352	CONNECTOR.....	2
13	8K8474	SPRING.....	1
	5K3702	FITTING.....	1
14	5K2651	NUT.....	1
	5K2650	SLEEVE.....	1
	1J9671	SEAL.....	1

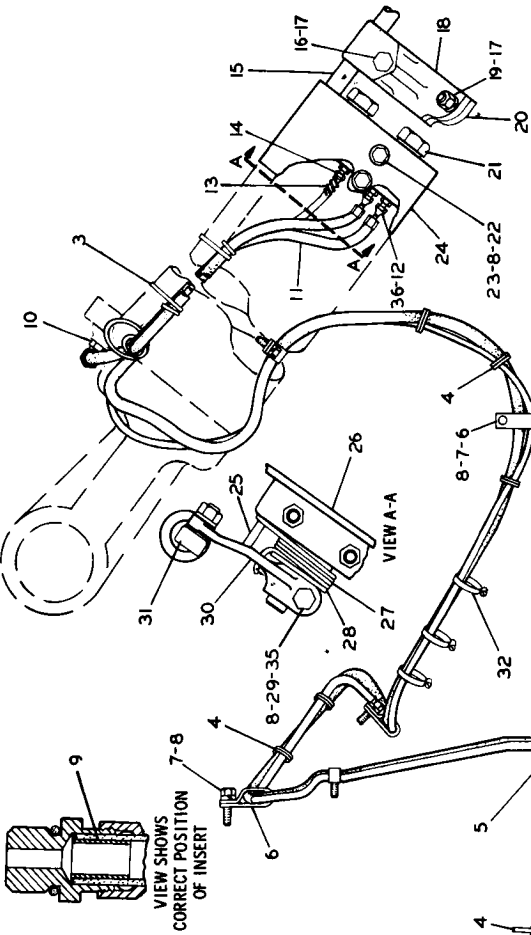

27	7K8660	SPRING.....	1
28	7K8659	WASHER.....	1
29	1D4717	NUT.....	1
30	8K85	LEVER.....	1
31	7K854	ROLLER.....	1
	1B4203	NUT.....	1
32	7H1442	CLAMP.....	3
33	8K8475	HOSE ASSEM. - (21' 6" long overall) -	1
C 34	307941	ELBOW.....	1
C 35	S1571	BOLT.....	1
C 36	3J7354	SEAL.....	3

21	1D4615	BOLT.....	2
	5H1504	WASHER.....	2
	7K8657	SPACER.....	2
C 22	S1591	BOLT.....	2
23	4B4278	WASHER.....	2
24	8K8477	HOUSING.....	1
25	2S696	DOWEL.....	1
26	8J82	VALVE GROUP.....	1

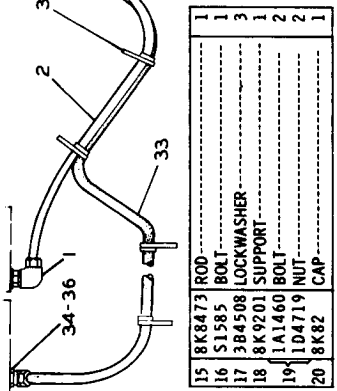

C INDICATES CHANGE

▲ ORDER BY THE FOOT

118990

CATERPILLAR 977L TRAXCAVATOR

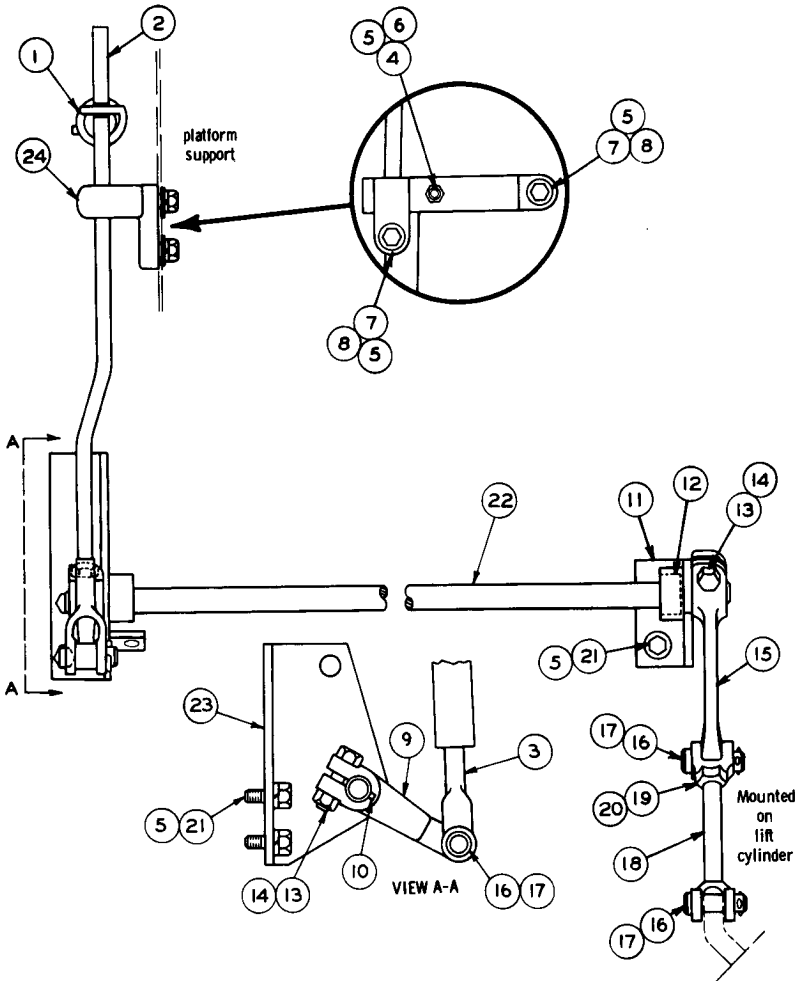

REF. NO.	PART NUMBER	DESCRIPTION	QTY.
1	6K1961	SPRING-----	1
2	6K1962	BAR ASSEM-----	1
3	1B4737	ROD END-----	1
4	5B9079	NUT-----	1
5	3B4506	LOCKWASHER-----	7
6	7K854	ROLLER-----	1
7	5509	BOLT-----	2
8	4B4278	WASHER-----	2
9	5K7087	LEVER-----	1
10	1B88704	KEY-----	2
11	6K7711	BRACKET ASSEM-----	1
12	4D2619	BEARING-----	2

13	3B1915	BOLT-----	2
14	1D4717	NUT-----	2
15	5K6521	LEVER-----	1
16	S175	PIN-----	3
17	3B4617	COTTER PIN-----	3
18	5K7090	ROD-----	1
19	1B4430	NUT-----	1
20	6F7010	ROD END-----	1
21	L1351	BOLT----- (.875" long)-----	4
		-OR-	
C	1A2029	BOLT----- (1.125" long)-----	4
22	5K7089	SHAFT-----	1
23	8S8757	BRACKET ASSEM-----	1
24	6K16	LEVER-----	1

C INDICATES CHANGE

116392

KICKOUT (5K6006 N/S)  
Serial No. 11K5051 to 11K6257 inclusive



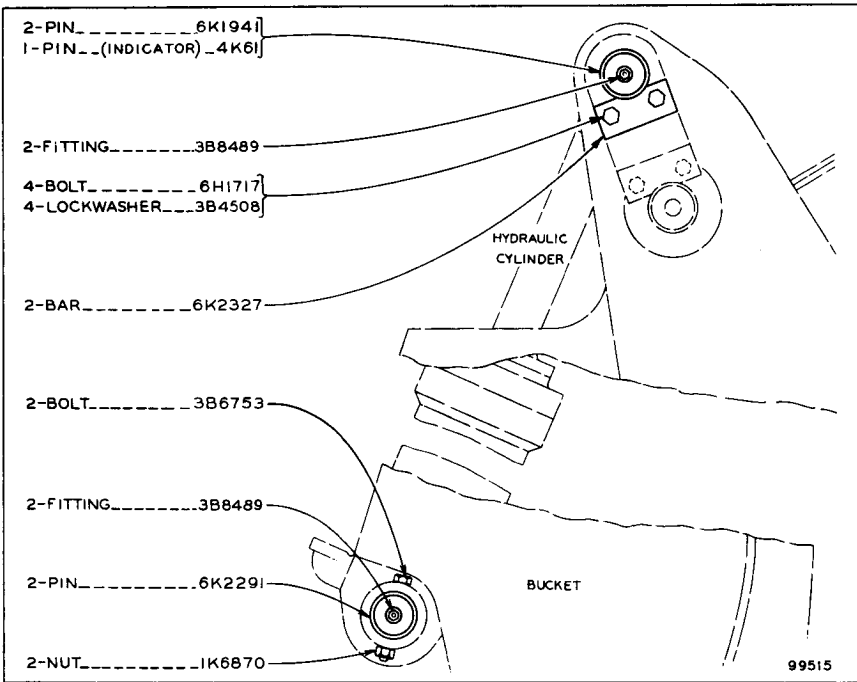

**6K2925 CYLINDER MOUNTING GROUP**

Part of 6K1096 Multi-Purpose Bucket Arrangement listed on Page 202A

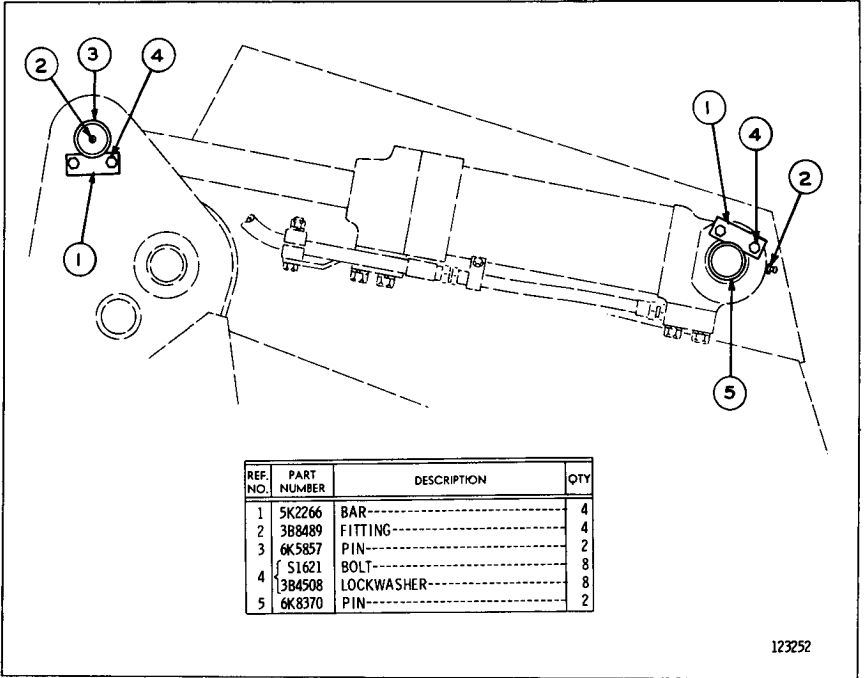

123252

**6K8364 CYLINDER MOUNTING GROUP**  
 Part of 7K8741 Demolition Bucket Arrangement listed on Page 208  
 AN ATTACHMENT

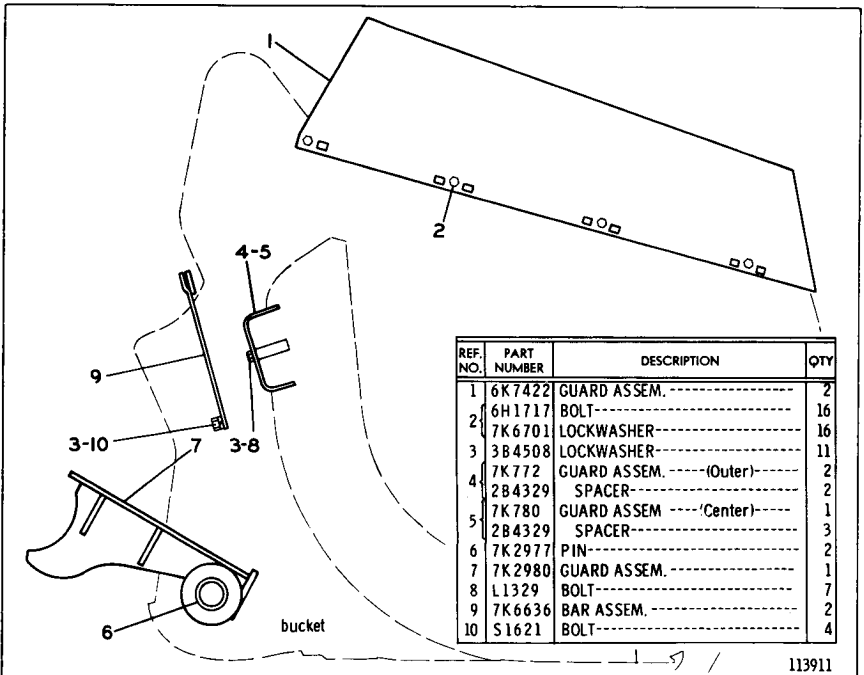

113911

**7K3399 DEMOLITION BUCKET GUARD**  
 Part of 7K8741 Demolition Bucket Arrangement listed on Page 208  
 AN ATTACHMENT

REF. NO.	PART NUMBER	DESCRIPTION	QTY
1	7K9849	LINK ASSEM. ....(rear)	2
2	7K9531	BEARING	4
3	5K7989	RING	4
4	5P66	SEAL	8
5	6K9084	BOLT	2
6	3B4516	LOCKWASHER	4
7	7K9375	PIN	10
8	6K7244	FITTING	10
9	5L595	BOLT	3
10	3B4508	LOCKWASHER	9
11	4F8686	BEARING	2
12	7K7026	SPRING	1
13	8K6145	LINK	1
14	1D4566	BOLT	1
15	1K6872	NUT	1
16	2M849	WASHER	1
17	7K9373	PIN	1
18	5K6383	PIN	2
19	1D4616	BOLT	2
20	1K6870	NUT	2
21	7K9851	ARM AND BEARING ASSEM. .... (includes)	1
22	7K9852	ARM ASSEM.	1
23	7K9532	BEARING	2
24	5B8855	PLATE	1
25	7K9528	BEARING	8
26	5K7988	RING	4
27	7K9227	WASHER	8
28	2K3656	BAR	1
29	6K1143	BAR	2
30	5K8003	BOLT	2
31	5K6377	PIN	2
32	5L585	BOLT	4
33	5P67	SEAL	4
34	5P68	SEAL	4
35	5P65	SEAL	8

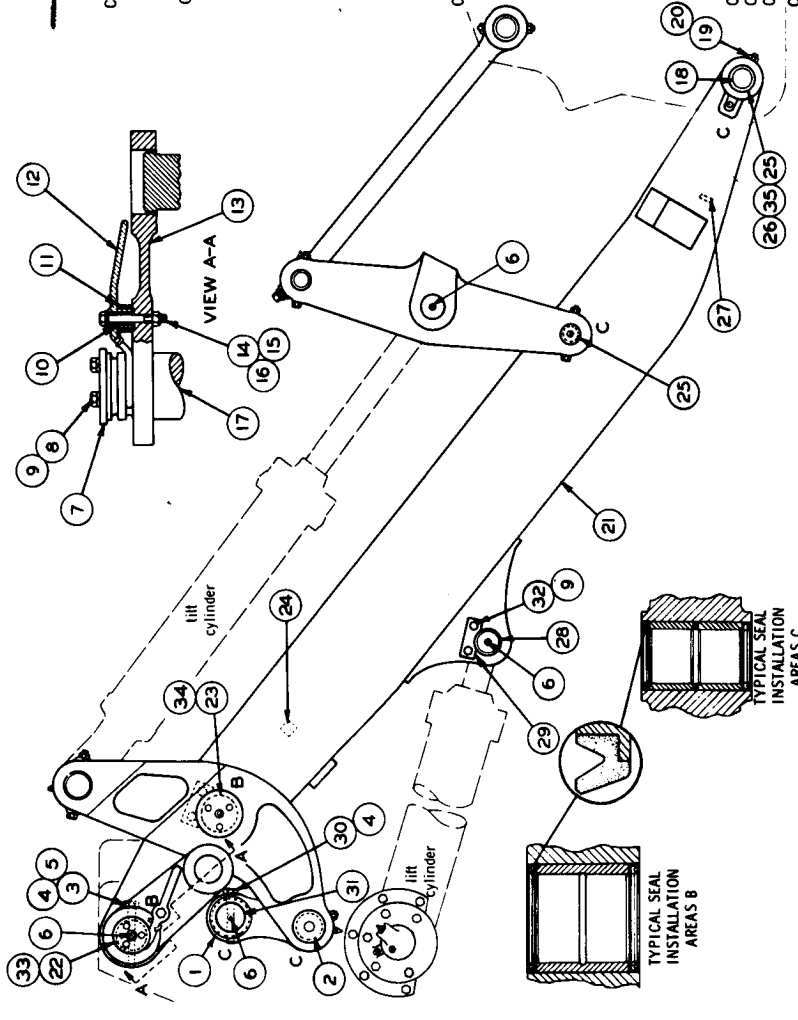

BUCKET CONTROL (7K9738 N/S)—Part 1

C INDICATES CHANGE

119198



BUCKET CONTROL (7K9738 N/S)—Part 2

REF. NO.	PART NUMBER	DESCRIPTION	QTY
1	5K8795	LEVER---(Right Hand-Outer)---	1
2	5K8793	LEVER---(Right Hand-Inner)---	1
3	5K8796	LEVER---(Left Hand-Outer)---	1
4	5K8794	LEVER---(Left Hand-Inner)---	1
5	5K6382	PIN-----	2

6	3B8489	FITTING-----	16
7	1D4621	BOLT-----	2
8	1K6870	NUT-----	6
9	51626	BOLT-----	4
10	3B4512	LOCKWASHER-----	4
11	5K7044	BAR-----	4
12	7K9370	PIN-----	2
13	6K1983	PIN-----	2
14	5K9367	PIN-----	2
15	1D4574	BOLT-----	4
16	1K6872	NUT-----	4
17	5K4135	LEVER---(Right Hand-Front)---	6
18	5K4136	LEVER---(Left Hand-Front)---	1
19	7K9850	LINK ASSEM.---(front)---	1
20	7K9529	BEARING-----	2
21	5P65	SEAL-----	8
22	1D4620	BOLT-----	2
23	5K6383	PIN-----	2
24	7K9374	PIN-----	2
25	51595	BOLT-----	2
26	5K6134	RETAINER-----	2
27	7K9366	PIN---(R. H.)---	1
28	2A1551	BOLT---(L. H.)---	1
29	6K9813	PLATE-----	2
30	51566	BOLT-----	32
31	1K6853	LOCKWASHER-----	4
32	3P2825	FITTING-----	32
33	7K9530	RETAINER ASSEM.---	2
34	5P73	BEARING-----	1
35	5K1234	SEAL-----	4
36	4D6475	HOSE ASSEM.---(1/4" Long Overall)---	2
37	3P2824	UNION-----	2
38	7K9530	RETAINER ASSEM.---	2
39	7K4541	BEARING-----	1
40	1D4616	BAR-----	2
		BOLT-----	2
		BOLT-----	2
41	3B4506	LOCKWASHER---(0.0625" Thick)---	2
	4B4278	WASHER---(0.0625" Thick)---	2
	1431	WASHER---(0.0937" Thick)---	2

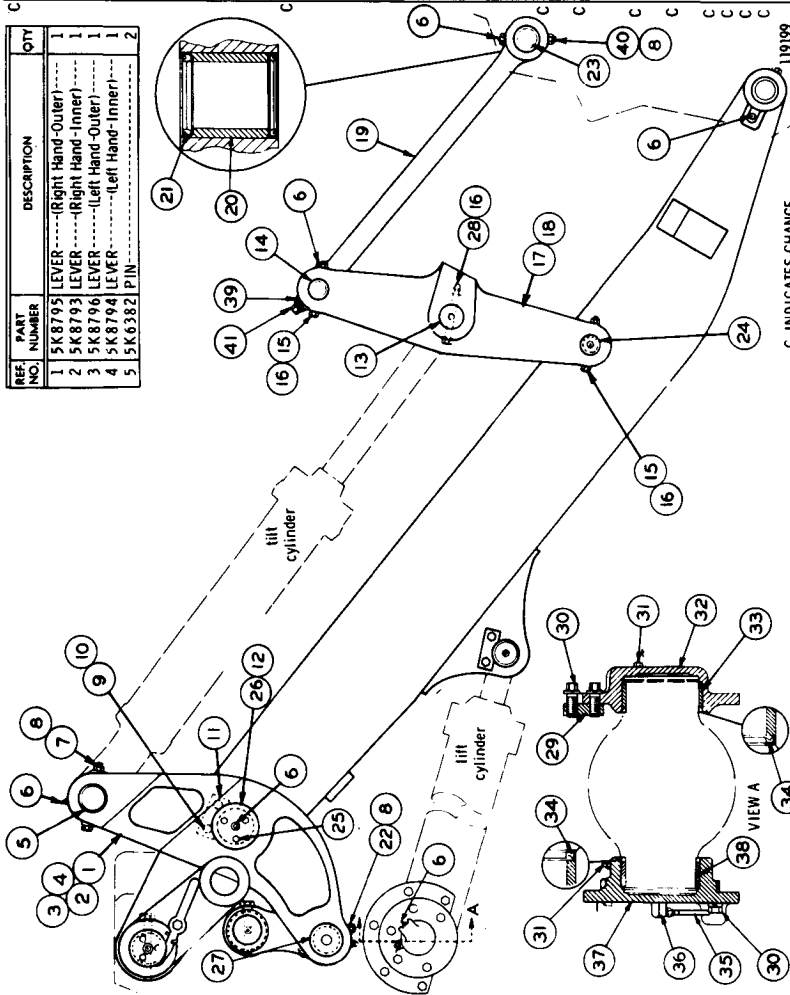

C INDICATES CHANGE

119199

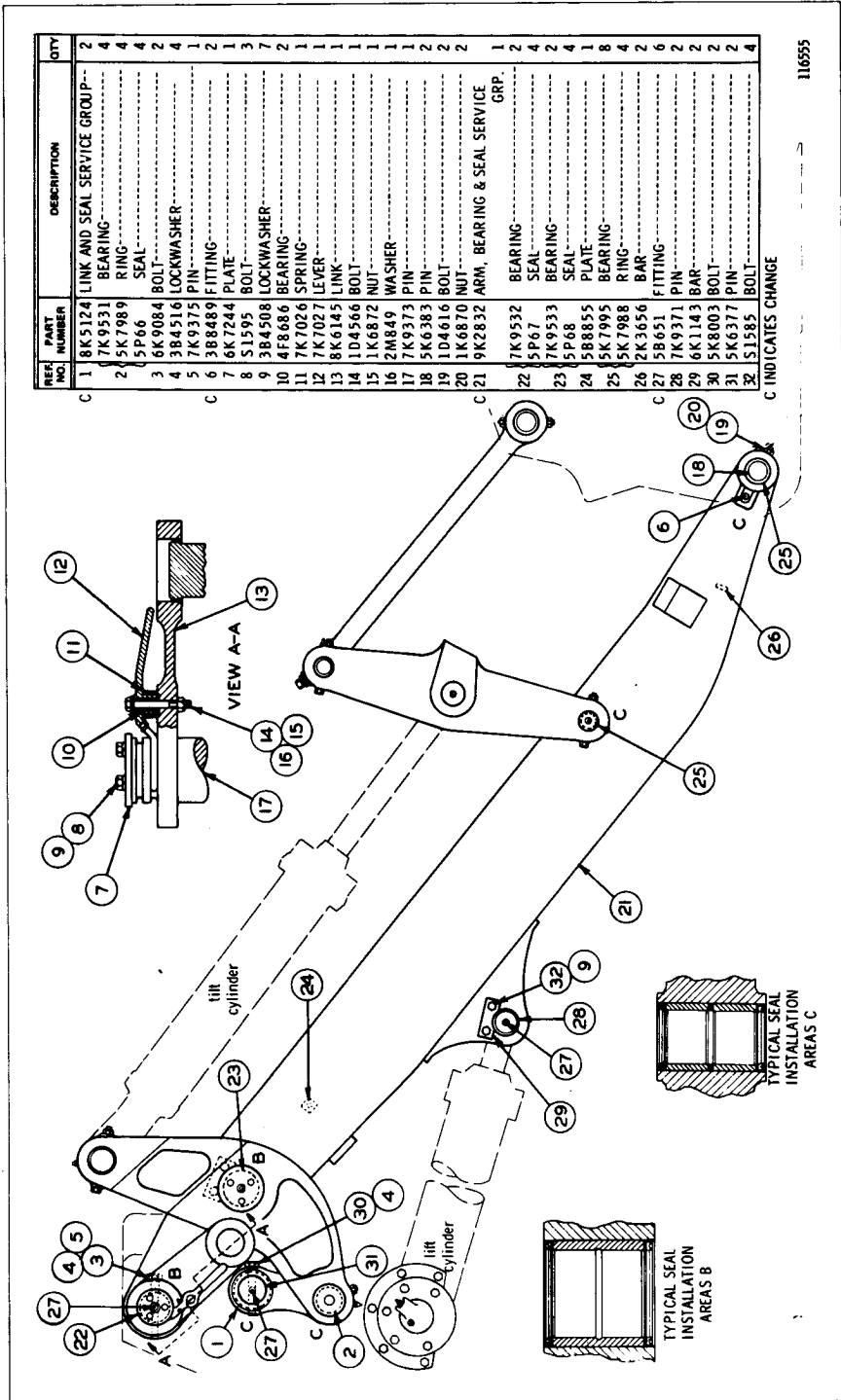

REF. NO.	PART NUMBER	DESCRIPTION	QTY
C 1	8K5124	LINK AND SEAL SERVICE GROUP--	2
2	7K9531	BEARING	4
3	5K7989	RING	4
4	5P66	SEAL	4
5	6K9084	BOLT	2
6	394516	LOCKWASHER	4
7	7K9375	PIN	1
8	388489	FITTING	2
9	7K7244	PLATE	1
10	5S1595	BOLT	2
11	384508	LOCKWASHER	7
12	4F8686	BEARING	2
13	7K7026	SPRING	1
14	7K7027	LEVER	1
15	8K6145	LINK	1
16	1D4566	BOLT	1
17	1K6872	NUT	1
18	2M849	WASHER	1
19	7K9373	PIN	1
20	5K6383	PIN	2
21	1D4616	BOLT	2
22	1K6870	NUT	2
C 23	9K2832	ARM, BEARING & SEAL SERVICE GRP.	1
24	7K9532	BEARING	2
25	5P67	SEAL	2
26	7K9533	BEARING	4
27	5P68	SEAL	4
28	588855	PLATE	4
29	5K7995	BEARING	8
30	5K7988	RING	2
31	2K3656	BAR	4
32	5B651	FITTING	2
33	7K9371	PIN	6
34	6K1143	BAR	2
35	5K8003	BOLT	2
36	5K6377	PIN	2
37	5S1585	BOLT	2
C INDICATES CHANGE			4

116555

5K6002 BUCKET CONTROL GROUP—Part 1  
 Part of 5S3270 and 1P9409 Steel Mill Traxcavator Arrangements listed on Pages 103 & 104  
 AN ATTACHMENT

5K6002 BUCKET CONTROL GROUP—Part 2  
 Part of 5S3270 and 1P9409 Steel Mill Traxcavator Arrangements listed on Pages 103 & 104  
 AN ATTACHMENT

REF. NO.	PART NUMBER	DESCRIPTION	QTY
1	5K8795	LEVER---(R. H. -Outer)	1
2	5K8793	LEVER---(R. H. -Inner)	1
3	5K8796	LEVER---(L. H. -Outer)	1
4	5K8794	LEVER---(L. H. -Inner)	1
5	5K6382	PIN	2
6	3B8489	FITTING	12
7	1D4621	BOLT	2
8	1K6870	NUT	6

9	51626	BOLT	4
10	3B4512	LOCKWASHER	4
11	5K7044	BAR	2
12	7K9370	PIN	2
13	6K1983	PIN	2
14	5K9367	PIN	2
15	1D4574	BOLT	4
16	1K6B72	NUT	6
17	5K4135	LEVER---(R. H. -Front)	1
18	5K4136	LEVER---(L. H. -Front)	1
19	7K1152	LINK ASSEM.	2
20	6K3177	BEARING	2
21	5B651	FITTING	4
22	1D4620	BOLT	2
23	5K6383	PIN	2
24	7K9374	PIN	2
25	51595	BOLT	6
26	3B4508	LOCKWASHER	6
27	5K6134	RETAINER	2
28	7K9366	PIN---(R. H.)	1
29	7K9369	PIN---(L. H.)	1
30	2A1531	BOLT	2
31	8K9813	PLATE	2
32	51566	BOLT	2
33	3B4510	LOCKWASHER	2
34	8K5354	RETAINER, BEARING & SEAL GRP.	2
35	3B8489	FITTING	1
36	1K6853	FITTING	1
37	7K9530	BEARING	1
38	5P73	SEAL	1
39	5K1234	HOSE ASSEM.---(14 in. long)	2
40	4D6475	UNION	2
41	8K5353	RETAINER, BEARING & SEAL GRP.	2
42	7K9530	BEARING	2
43	5P73	SEAL	1
44	1K6853	FITTING	1
45	51588	BOLT	1
46	3B4506	LOCKWASHER	2
47	4B4278	WASHER---(.0625 in. thick)	2
48	1T431	WASHER---(.0937 in. thick)	2
49	7K4541	BAR	2
50	1D4616	BOLT	2

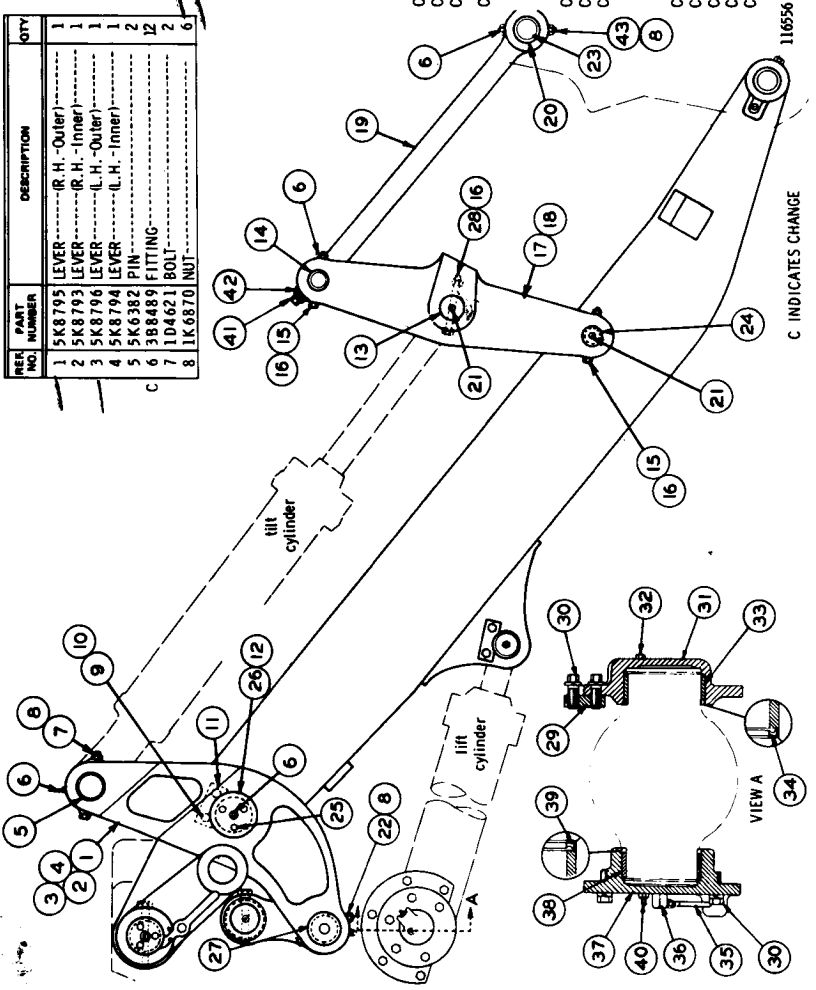

C INDICATES CHANGE

116556

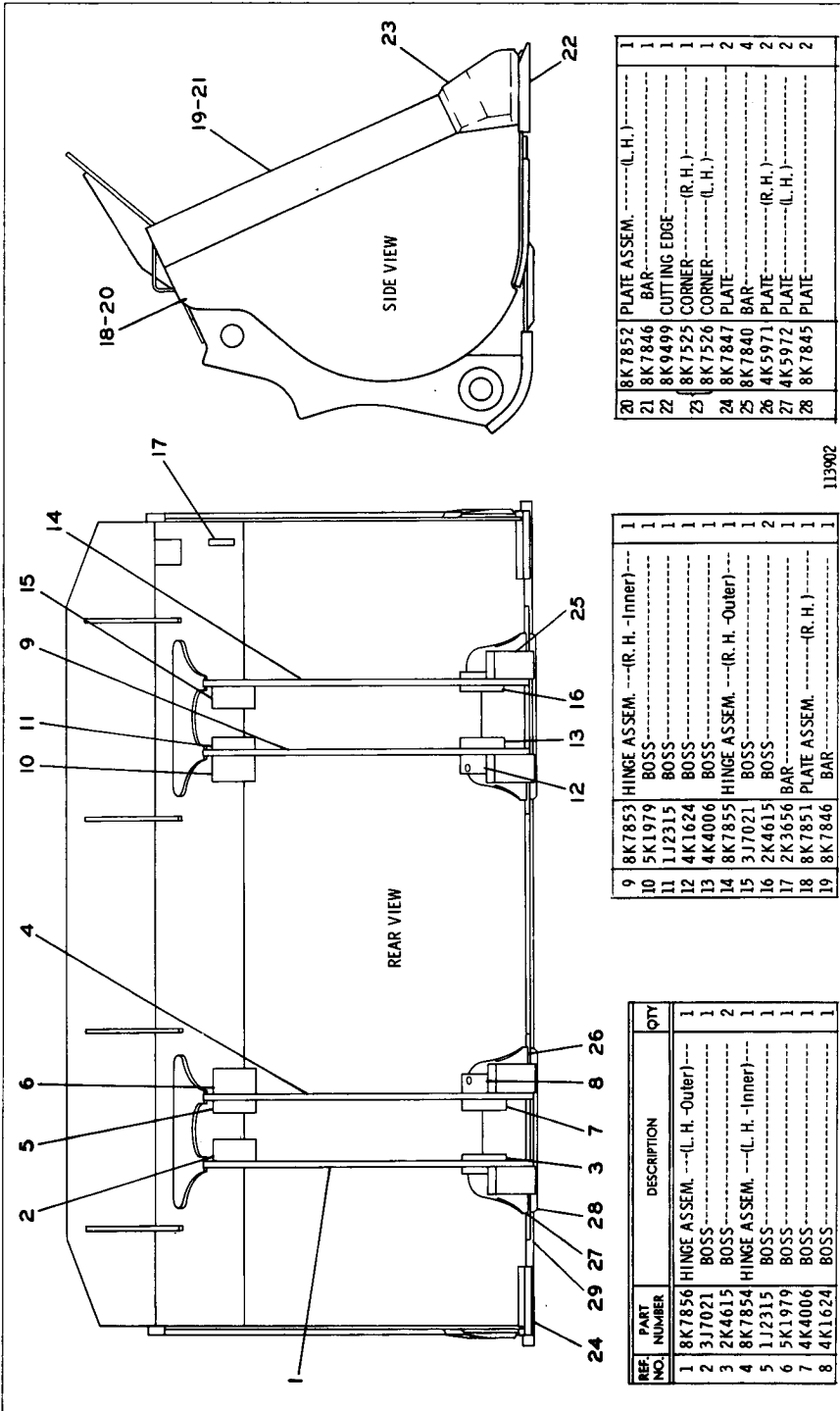

113902

8K9501 GENERAL PURPOSE BUCKET ASSEMBLY—2.75 Cu. Yd.—98" Wide AN ATTACHMENT

CONSISTS OF:			PAGE
1	6J1165	CYLINDER GROUP (R.H.).....	122A
1	6J1166	CYLINDER GROUP (L.H.).....	122A
1	6K2306	BUCKET GROUP.....	122B
1	6K2564	FRONT LINES GROUP.....	185B
1	6K2925	CYLINDER MOUNTING GROUP.....	196B

6K1096 MULTI-PURPOSE BUCKET ARRANGEMENT  
 2.5 Cubic Yard—96" Wide  
 Only separate parts serviced. AN ATTACHMENT

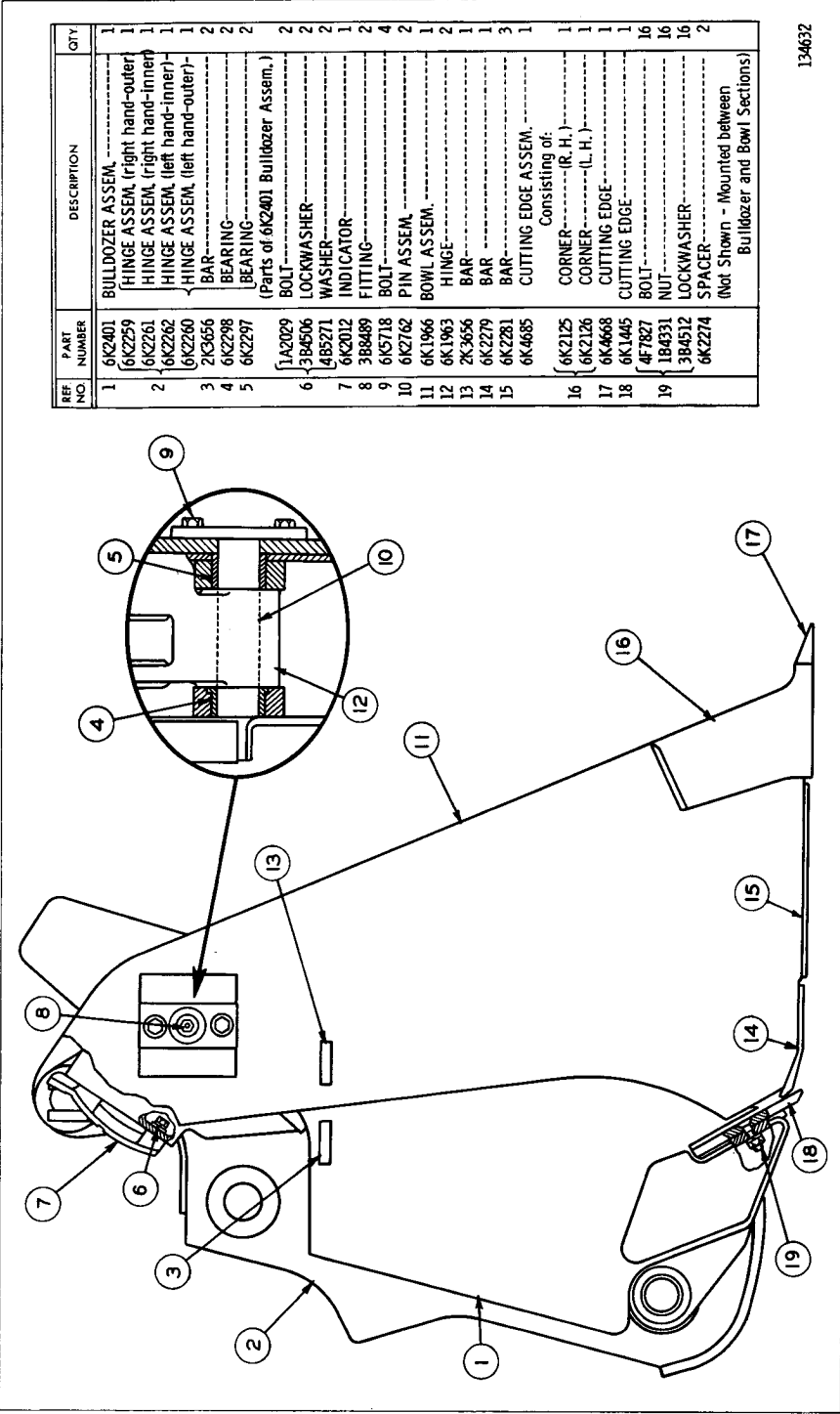

REF NO	PART NUMBER	DESCRIPTION	QTY
1	6K2401	BULLDOZER ASSEM.	1
	{ 6K2259	HINGE ASSEM, (right hand-outer)	1
2	6K2261	HINGE ASSEM, (right hand-inner)	1
	{ 6K2262	HINGE ASSEM, (left hand-inner)	1
3	6K2260	HINGE ASSEM, (left hand-outer)	1
4	2K3656	BAR	2
5	6K2298	BEARING	2
	{ 6K2297	(Parts of 6K2401 Bulldozer Assem.)	2
6	1A2029	BOLT	2
	{ 3B4506	LOCKWASHER	2
7	4B5271	WASHER	2
8	6K2012	INDICATOR	1
9	3B8489	FITTING	2
10	6K5718	BOLT	4
11	6K2762	PIN ASSEM.	2
12	6K1966	BOWL ASSEM.	1
13	6K1963	HINGE	2
14	2K3656	BAR	1
15	6K2279	BAR	1
	{ 6K2281	BAR	3
	{ 6K4685	CUTTING EDGE ASSEM.	1
		Consisting of:	
16	{ 6K2125	CORNER	1
	{ 6K2126	CORNER	1
17	6K4668	CUTTING EDGE	1
18	6K1445	CUTTING EDGE	1
19	4F7827	BOLT	16
	{ 1B4331	NUT	16
	{ 3B4512	LOCKWASHER	16
	{ 6K2274	SPACER	16
		(Not Shown - Mounted between Bulldozer and Bowl Sections)	2

134632

6K2306 BUCKET GROUP—2.5 Cubic Yard—96" Wide  
Part of 6K1096 Multi-Purpose Bucket Arrangement listed on Page 202A

8K9500 LOOSE MATERIAL BUCKET ASSEMBLY—3.25 Cu. Yd.—98" Wide  
AN ATTACHMENT

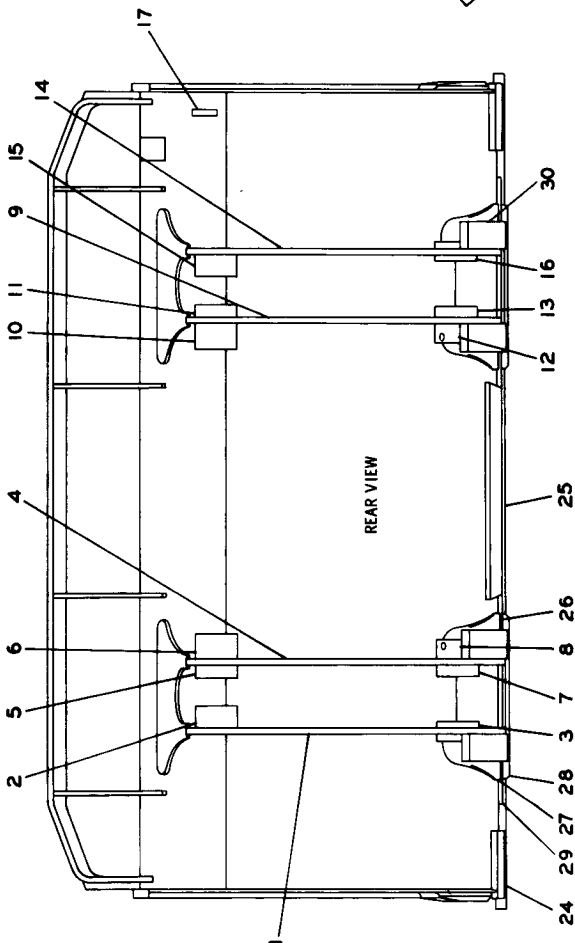

SIDE VIEW

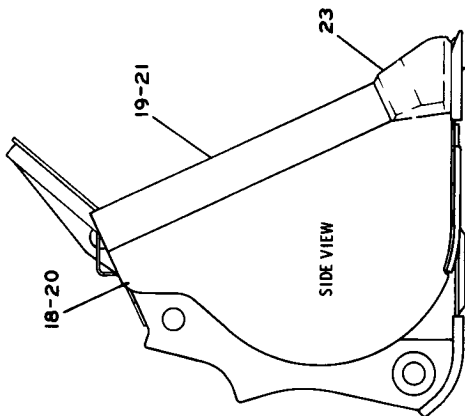

REF. NO.	PART NUMBER	DESCRIPTION	QTY
1	8K7856	HINGE ASSEM.---(L. H.-Outer)---	1
2	3J7021	BOSS-----	1
3	2K4615	BOSS-----	2
4	8K7854	HINGE ASSEM.---(L. H.-Inner)---	1
5	1J2315	BOSS-----	1
6	5K1979	BOSS-----	1
7	4K4006	BOSS-----	1
8	4K1624	BOSS-----	1

9	8K7853	HINGE ASSEM.---(R. H.-Inner)---	1
10	5K1979	BOSS-----	1
11	1J2315	BOSS-----	1
12	4K1624	BOSS-----	1
13	4K4006	BOSS-----	1
14	8K7855	HINGE ASSEM.---(R. H.-Outer)---	1
15	3J7021	BOSS-----	1
16	2K4615	BOSS-----	2
17	2K3656	BAR-----	1
18	8K7975	PLATE ASSEM.---(R. H.)---	1
19	8K7974	BAR-----	1

C. INDICATES CHANGE

20	8K7976	PLATE ASSEM.---(L. H.)---	1	
21	8K7974	BAR-----	1	
22	8K9499	CUTTING EDGE	1	
23	8K7525	CORNER---(R. H.)---	1	
24	8K7526	CORNER---(L. H.)---	1	
25	8K7977	PLATE	2	
26	4K5971	PLATE---(R. H.)---	2	
27	4K5972	PLATE---(L. H.)---	2	
28	8K7845	PLATE	2	
C	29	9K8122	PLATE	2
C	30	9K8121	BAR	4

119404

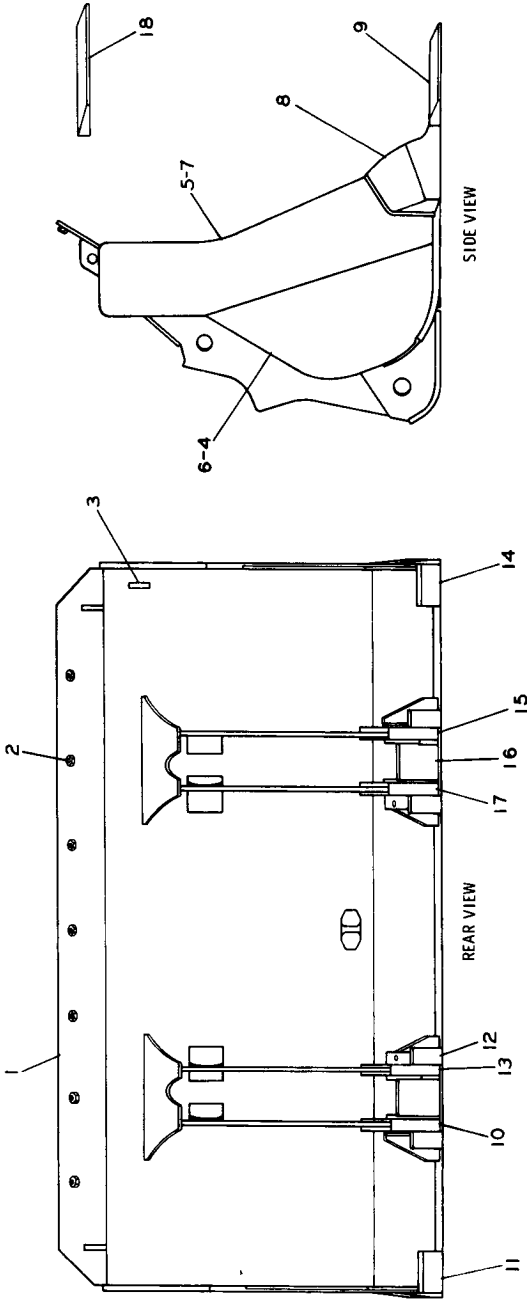

REF. NO.	PART NUMBER	DESCRIPTION	QTY
1	6K610	PLATE	1
2	1B4331	NUT	7
3	2K3656	BAR	1
4	6K2023	PLATE ASSEM. ----(Right Hand)	1
5	6K603	PLATE (Part of 6K2023 Assem.)	1
6	6K2024	PLATE ASSEM. ----(Left Hand)	1
7	6K604	PLATE (Part of 6K2024 Assem.)	1

8	6K5255	CUTTING EDGE ASSEM.	1
9	6K5254	CUTTING EDGE ----(R. H.)	1
9	4K9757	CORNER ----(L. H.)	1
9	4K9758	CORNER ----(L. H., Outer)	1
10	6K600	HINGE ASSEM. ----(L. H., Outer)	1
11	6K264	BAR ----(L. H.)	1
12	6K605	BAR	4
13	6K602	HINGE ASSEM. ----(L. H., Inner)	1

14	6K263	BAR ----(Right Hand)	1
15	6K599	HINGE ASSEM. ----(Right Hand Outer)	1
16	6K606	PLATE	2
17	6K601	HINGE ASSEM. ----(Right Hand Inner)	1
▲ 18	6K7032	CUTTING EDGE	1
	FE035705	FORM	1
(Instructions for installing Cutting Edge Group)			
▲ FIELD REPLACEMENT-NOT PART OF 6K594 ASSEM.			119400

6K594 ROCK LOADING BUCKET ASSEMBLY—3 Cu. Yd.—104.50" Wide AN ATTACHMENT



6K500 SLAG BUCKET ASSEMBLY—2.5 Cu. Yd.—96.5" Wide  
AN ATTACHMENT

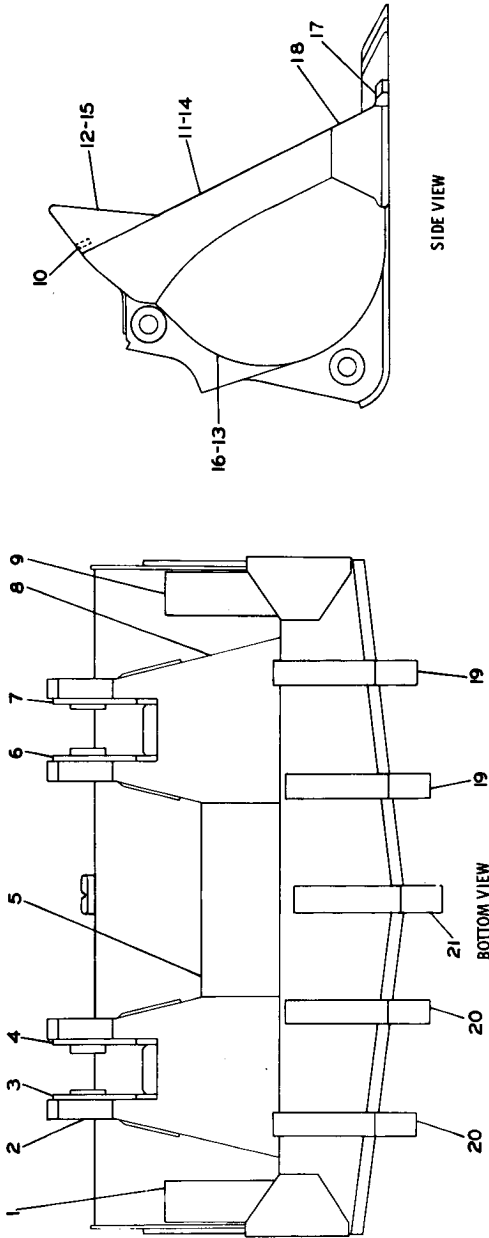

REF. NO.	PART NUMBER	DESCRIPTION	QTY
1	6K476	PLATE—(L.H.)	1
2	6K294	PLATE	4
3	6K296	HINGE ASSEM.—(L.H.—Outer)	1
4	6K312	HINGE ASSEM.—(L.H.—Inner)	1
5	6K327	PLATE	1
6	6K311	HINGE ASSEM.—(R.H.—Inner)	1
7	6K295	HINGE ASSEM.—(R.H.—Outer)	2
8	6K587	PLATE	1
9	6K475	PLATE—(R.H.)	1

10	2K3656	BAR	1
11	6K1437	PLATE ASSEM.—(R.H.)	1
12	4K4341	PLATE	1
13	5K7309	PLATE	1
14	6K1438	PLATE ASSEM.—(L.H.)	1
15	5K7308	PLATE	1
16	5K7309	PLATE	1

17	5K455	EDGE ASSEM.	1
18	5K443	EDGE	1
19	6K203	CORNER—(R.H.)	2
20	6K204	TOOTH—(L.H.)	2
21	2K202	TOOTH—(Center)	1

119401

FM055154-FORM-----1  
 (Instructions for installing Bucket Teeth)

REF. NO.	PART NUMBER	DESCRIPTION	QTY.
1	5K6061	HINGE ASSEM. ----- (Right Hand-Outer)	1
	5K6063	HINGE ASSEM. ----- (Right Hand-Inner)	1
	5K6062	HINGE ASSEM. ----- (Left Hand-Outer)	1
	5K6064	HINGE ASSEM. ----- (Left Hand-Inner)	1
2	2K3656	BAR-----	2
3	1B4331	NUT-----	7
4	4K33	PIN-----	7
5	4K6	PLUG-----	7
6	6K7228	TIP-----	7
7	6K5752	EDGE ASSEM. -----	1
	6K5751	EDGE-----	1
8	6K2853	ADAPTER----- (Parts of 6K5752 Assem.)	7
9	7K387	BAR-----	2

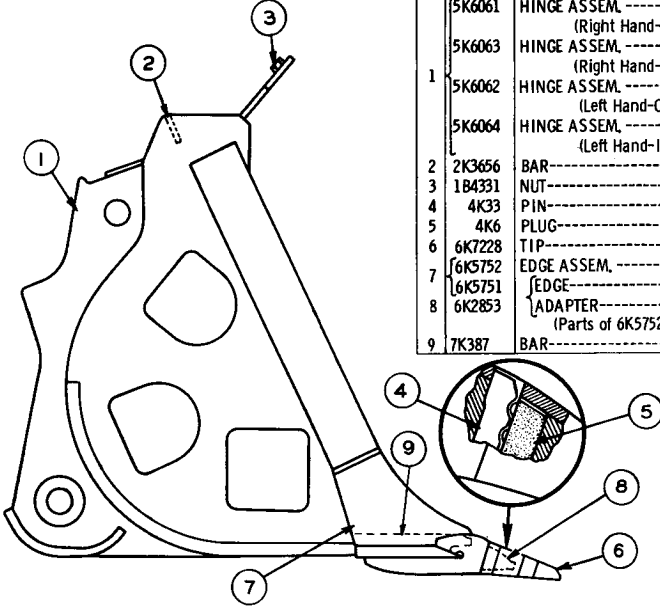

128629

6K2750 SKELETON ROCK BUCKET ASSEMBLY—2.5 Cu. Yd.—96" Wide  
 AN ATTACHMENT

CONSISTS OF:

PAGE

1	5J9893	CYLINDER GROUP.....	137
	- OR -		
1	8J5749	CYLINDER GROUP.....	138
1	6K904	BUCKET AND SUPPORT GROUP.....	207
1	6K1721	HYDRAULIC LINES GROUP.....	187

6K707 SIDE DUMP BUCKET ARRANGEMENT  
 FOR USE WITH THIRD HYDRAULIC VALVE AND COUNTERWEIGHT  
 Only separate parts serviced. AN ATTACHMENT

6K904 BUCKET AND SUPPORT GROUP—2.5 Cu. Yd.—111" Wide  
Part of 6K707 Side Dump Bucket Arrangement  
AN ATTACHMENT

REF NO	PART NUMBER	DESCRIPTION	QTY
1	1B4602	PLUG	2
2	6K571	SPRING	1
3	6K734	COVER	1
3	7K735	GASKET	1
4	S1594	BOLT	3
4	3B4506	LOCKWASHER	3
5	6K553	PIN	1
6	5H1513	SEAL	1
7	3K5628	PLATE	1
8	S1621	BOLT	4
8	3B4508	LOCKWASHER	4
9	6K702	PIN	1

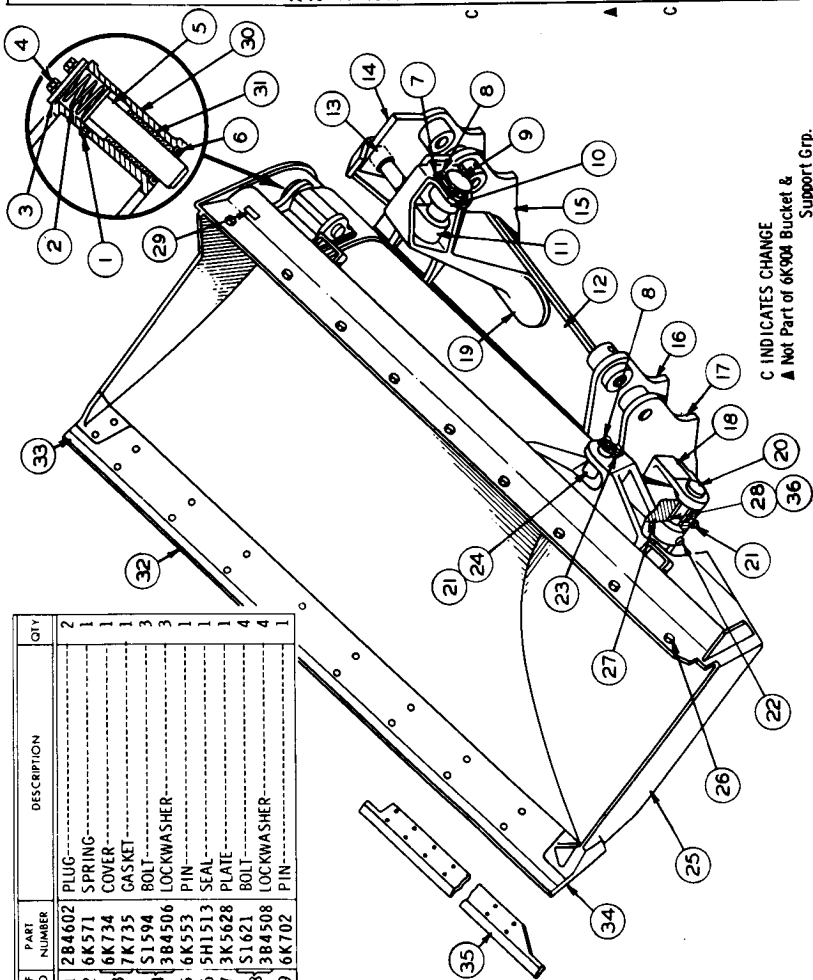

C INDICATES CHANGE  
▲ Not Part of 6K904 Bucket & Support Grp.

10	6K320	SPACER	1	
11	6K813	PIN ASSEM.	1	
12	6K584	SUPPORT ASSEM.	1	
13	6K331	BEARING	1	
14	6K681	HINGE ASSEM. (r. h. upper-outer)	1	
14	6K675	HINGE ASSEM. (r. h. lower-outer)	1	
15	6K679	HINGE ASSEM. (r. h. upper-inner)	1	
15	6K677	HINGE ASSEM. (r. h. lower-inner)	1	
16	6K682	HINGE ASSEM. (l. h. upper-inner)	1	
16	6K678	HINGE ASSEM. (l. h. lower-inner)	1	
17	6K680	HINGE ASSEM. (l. h. upper-outer)	1	
18	6K340	HINGE ASSEM. (l. h. lower-outer)	1	
19	6K668	BRACKET	1	
19	6K668	MOUNTING	1	
20	6K715	PIN	2	
21	3B8489	FITTING	3	
22	1D4572	BOLT	2	
22	1K6872	NUT	2	
23	2K703	WASHER BAR	1	
24	6K695	PIN	1	
25	6K812	BUCKET ASSEM.	1	
26	1B4331	NUT	9	
27	6K505	HINGE	2	
28	9K681	BEARING	2	
C	29	2K3656	BAR	2
30	6K667	LATCH ASSEM.	1	
31	6K555	BEARING	1	
32	6K5728	CUTTING EDGE ASSEM.	1	
33	5K9099	CORNER—(R. H.)	1	
34	6K3719	CORNER—(L. H.)	1	
▲	35	6K5732	CUTTING EDGE (Field Replacement for Standard Cutting Edge)	1
C	36	7K9205	SEAL	4

140042

CONSISTS OF:		PAGE
2	6J7056 HYDRAULIC CYLINDER GROUP.....	135
	- OR -	
2	9K3177 HYDRAULIC CYLINDER GROUP.....	136
1	6K7584 HYDRAULIC LINES GROUP.....	188
1	6K8364 CYLINDER MOUNTING GROUP.....	197
1	7K3399 DEMOLITION GUARD GROUP.....	197
1	7K6708 DEMOLITION BUCKET GROUP.....	208B

**7K8741 DEMOLITION BUCKET ARRANGEMENT**

FOR USE WITH 3P1887 RADIATOR GUARD AND 2P9757 COUNTERWEIGHT SHOWN ON PAGES 16 AND 102. Only separate parts serviced. When complete Arrangement is required order 1V8152 or 1V8153 Arrangements listed on Page 208A. AN ATTACHMENT

CONSISTS OF:			PAGE
1	6J7584	HYDRAULIC LINES GROUP.....	188
1	6K8364	CYLINDER MOUNTING GROUP.....	197
1	7K3399	DEMOLITION GUARD GROUP.....	197
1	7K6708	DEMOLITION BUCKET GROUP.....	208B
2	8J5761	CYLINDER GROUP.....	136
1	2P9762	COUNTERWEIGHT GROUP.....	102A

1V8152 DEMOLITION BUCKET ARRANGEMENT  
 FOR USE WITH 2P8538 ROLL-OVER PROTECTIVE STRUCTURE SHOWN ON  
 PAGES 246 AND 247. Only separate parts serviced. AN ATTACHMENT

CONSISTS OF:			PAGE
1	6K7584	HYDRAULIC LINES GROUP.....	188
1	6K8364	CYLINDER MOUNTING GROUP.....	197
1	7K3399	DEMOLITION GUARD GROUP.....	197
1	7K6708	DEMOLITION BUCKET GROUP.....	208B
2	8J5761	CYLINDER GROUP.....	136
1	2P9758	COUNTERWEIGHT GROUP.....	102A

1V8153 DEMOLITION BUCKET ARRANGEMENT  
 CANNOT BE USED WITH ROLL-OVER PROTECTIVE STRUCTURE  
 Only separate parts serviced. AN ATTACHMENT

C INDICATES CHANGE

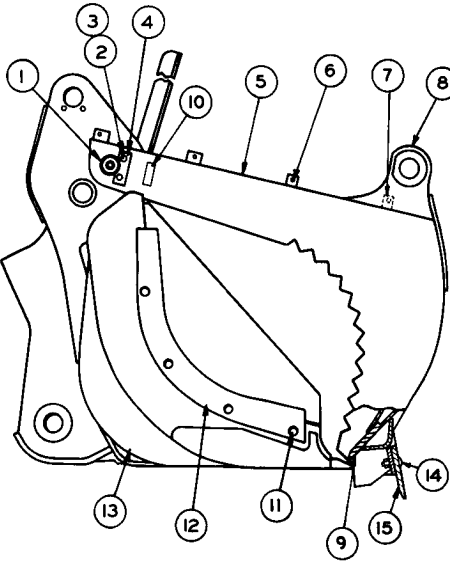

REF. NO.	PART NUMBER	DESCRIPTION	QTY
1	6K8374	PIN-----	2
1	3B8489	FITTING-----	2
2	51621	BOLT-----	4
3	3B4508	LOCKWASHER-----	4
4	5K2266	BAR-----	2
5	7K6704	CLAMP ASSEM.-----	1
6	2K2099	BAR-----	4
7	6K619	LUG-----	4
	6K7302	HINGE ASSEM.-----	2
8		(R. H. Inner - L. H. Outer)	
	6K7301	HINGE ASSEM.-----	2
		(R. H. Outer - L. H. Outer)	
9	6K7418	CUTTING EDGE-----	1
10	2K3656	BAR-----	1
11	1J6762	BOLT-----	8
	2J3506	NUT-----	8
12	6K7473	PLATE ASSEM.----- (R. H.)-----	1
	6K7474	PLATE ASSEM.----- (L. H.)-----	1
13	7K6707	BUCKET ASSEM.----- (See Separate Illustration)	1
14	4F3654	BOLT-----	22
	4K367	NUT-----	22
15	5J6906	CUTTING EDGE-----	1

113910

7K6708 DEMOLITION BUCKET GROUP—96" Wide  
Part of 7K8741, 1V8152 and 1V8153 Demolition Bucket Arrangements  
listed on Pages 208 and 208A

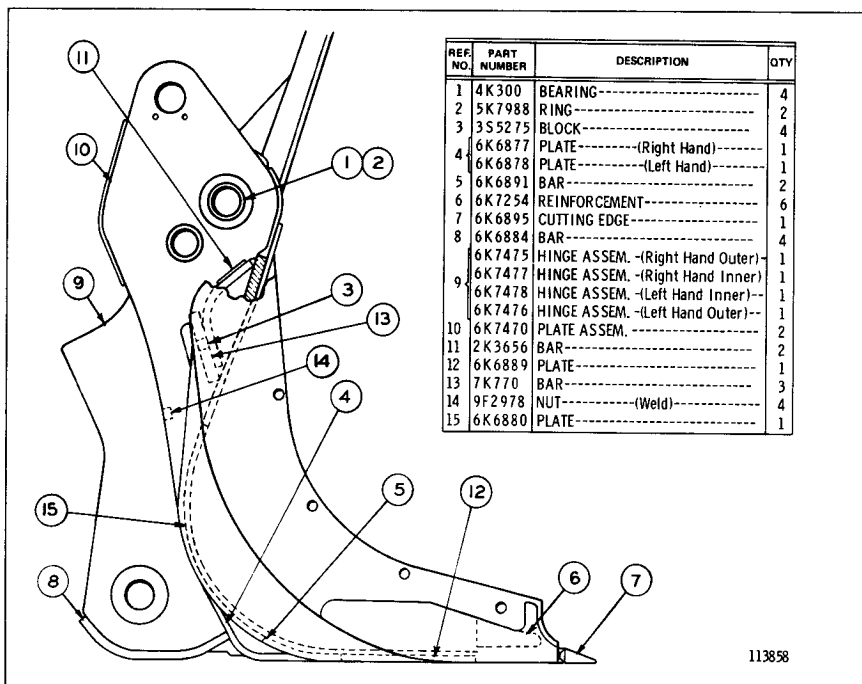

7K6707 BUCKET ASSEMBLY  
Part of 7K6708 Demolition Bucket Group  
AN ATTACHMENT

CONSISTS OF:			PAGE
2	6J4513	CYLINDER GROUP.....	139
	- OR -		
2	8J5755	CYLINDER GROUP.....	140
1	6K6297	TOP CLAMP GROUP.....	210
1	6K6574	HYDRAULIC LINES GROUP.....	190
1	.....	FORM FM055146	

6K1009 TOP CLAMP ARRANGEMENT  
FOR USE WITH 6K1008 LOG FORK GROUP SHOWN ON PAGE 210  
Only separate parts serviced. AN ATTACHMENT

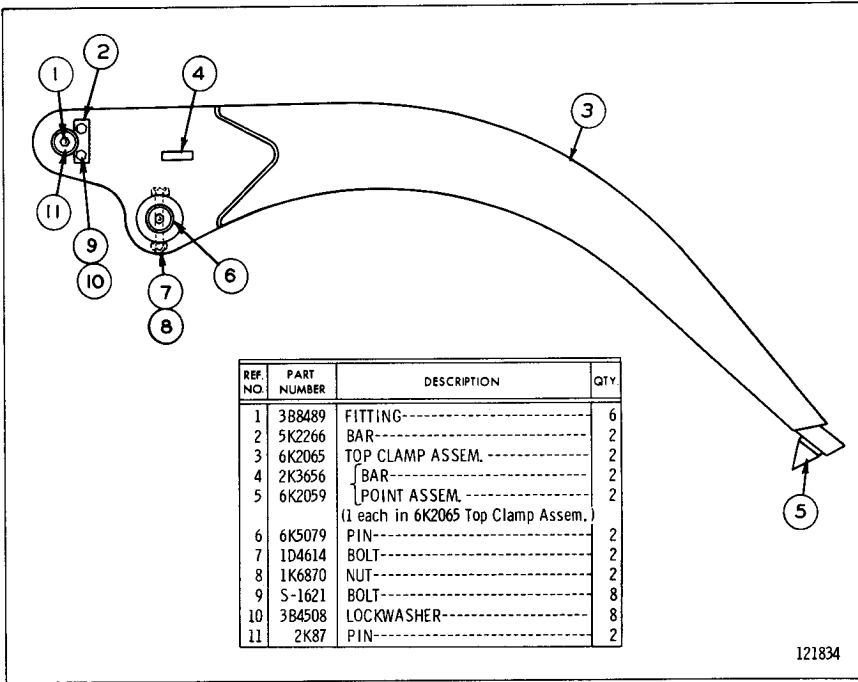

121834

6K6297 TOP CLAMP GROUP

Part of 6K1009 Top Clamp Arrangement listed on Page 209  
AN ATTACHMENT

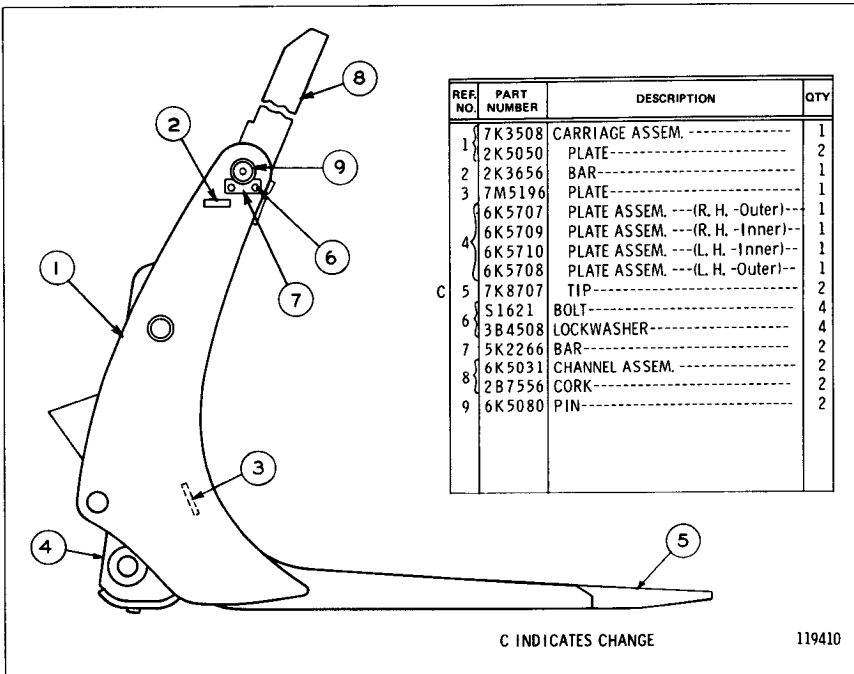

C INDICATES CHANGE

119410

6K1008 LOG FORK GROUP  
AN ATTACHMENT



A cross-sectional diagram of a tooth group attachment. It shows a central shaft with a nut (1) and an adapter (2) on top. A plug (3) is inserted into the side of the shaft. The tip of the tooth is labeled (4). A bolt (5) is shown at the base of the tooth, and another bolt (6) is shown at the base of the shaft.

REF NO	PART NUMBER	DESCRIPTION	QTY
1	2J3505	NUT-----	16
2	5K9024	ADAPTER-----	8
3	4K8	PLUG-----	8
4	5K2926	TIP-----	8

REF NO	PART NUMBER	DESCRIPTION	QTY
5	4K32	PIN-----	8
6	1D4629	BOLT-----	16
	FE034898	FORM-----	1
(Instructions for installing Conical Type Bucket Teeth)			

99491

5K9023 TOOTH GROUP—Short Tip  
FOR USE WITH GENERAL PURPOSE, LOOSE MATERIAL AND  
MULTI-PURPOSE BUCKETS. AN ATTACHMENT

A cross-sectional diagram of a tooth group attachment, similar to the one above but with a different tip shape. It shows a central shaft with a nut (1) and an adapter (2) on top. A plug (3) is inserted into the side of the shaft. The tip of the tooth is labeled (4). A bolt (5) is shown at the base of the tooth, and another bolt (6) is shown at the base of the shaft.

REF. NO.	PART NUMBER	DESCRIPTION	QTY.
1	2J3505	NUT-----	18
2	5K9024	ADAPTER-----	9
3	4K8	PLUG-----	9
4	5K2926	TIP-----	9

REF. NO.	PART NUMBER	DESCRIPTION	QTY.
5	4K32	PIN-----	9
6	1D4629	BOLT-----	9
	34898	FORM--(Installation Instructions)	1

99492

6K1340 TOOTH GROUP—Short Tip  
FOR USE WITH GENERAL PURPOSE AND SIDE DUMP BUCKETS  
AN ATTACHMENT

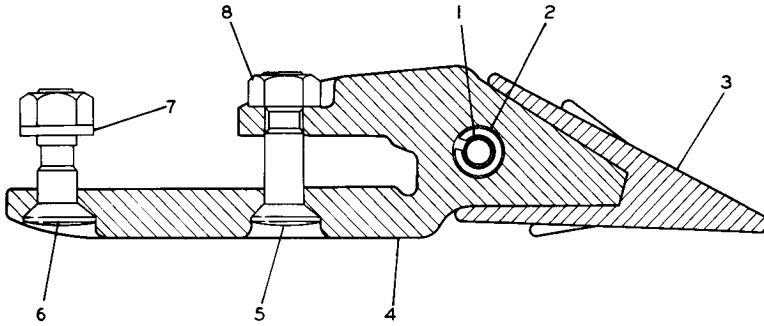

REF. NO.	PART NUMBER	DESCRIPTION	QTY
1	7J6846	PIN-----	7
2	7J6845	SPRING-----	7
3	8J3351	TIP----- (Heavy Duty)	7

4	8J3357	ADAPTER-----	7
5	8J2928	BOLT-----	14
6	4J9058	BOLT-----	7
7	3K5234	WASHER-----	7
8	2J3507	NUT-----	21

113903

**8J4208 TOOTH GROUP**  
 FOR USE WITH GENERAL PURPOSE AND LOOSE MATERIAL BUCKETS. Only separate parts serviced. When complete Group is required, order 9J2747 AN ATTACHMENT

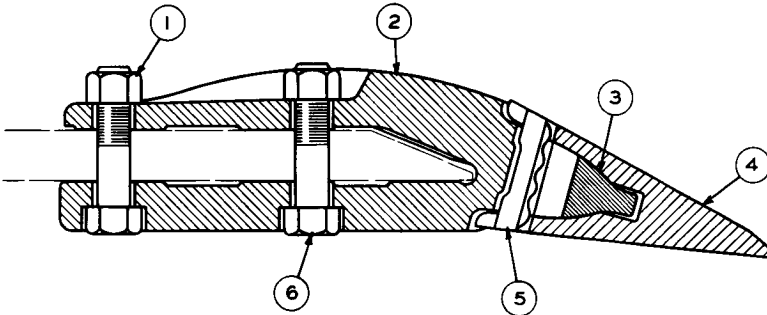

REF NO	PART NUMBER	DESCRIPTION	QTY
1	2J3505	NUT-----	16
2	5K9024	ADAPTER-----	8
3	4K8	PLUG-----	8
4	6K7227	TIP-----	8

REF. NO.	PART NUMBER	DESCRIPTION	QTY
5	4K32	PIN-----	8
6	1D4629	BOLT-----	16
	FE034898-04	FORM----- (Instructions for installing Conical Type Bucket Teeth)	1

126033

**7K3231 TOOTH GROUP—Short Tip**  
 FOR USE WITH DEMOLITION BUCKETS  
 AN ATTACHMENT

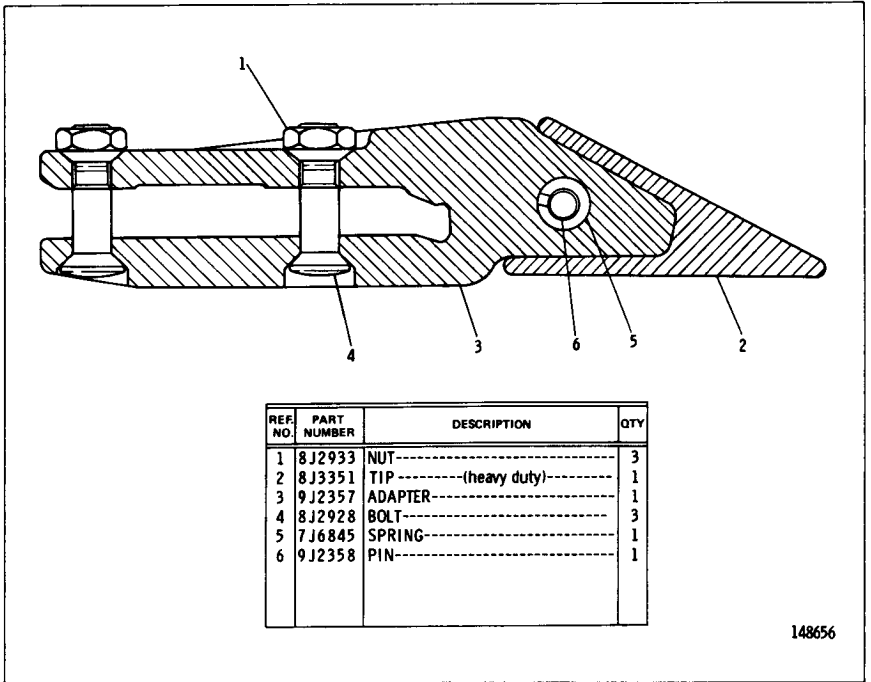

148656

9J2747 TOOTH GROUP—Short Tip—7 Required—Type 1  
FOR USE WITH 8K9500 AND 8K9501 BUCKET ASSEMBLIES  
AN ATTACHMENT

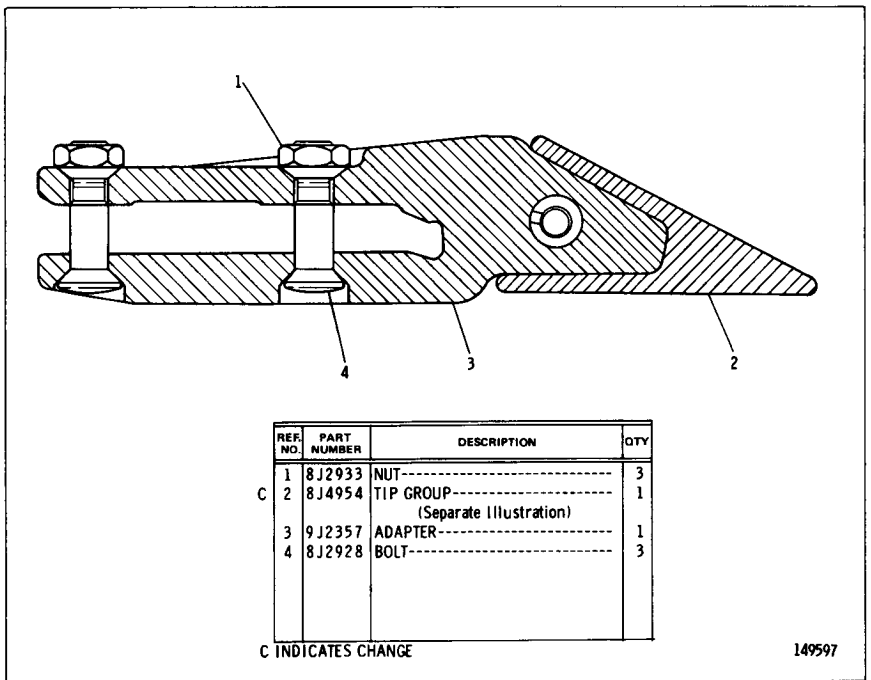

C INDICATES CHANGE

149597

9J2747 TOOTH GROUP—Short Tip—7 Required—Type 2  
FOR USE WITH 8K9500 AND 8K9501 BUCKET ASSEMBLIES  
8J4954 Tip parts are shown on Page 212B  
AN ATTACHMENT

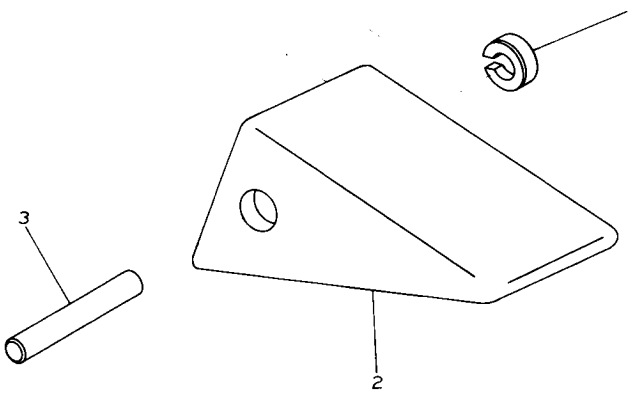

REF. NO.	PART NUMBER	DESCRIPTION	QTY
1	7J6845	SPRING-----	1
C 2	9J4351	TIP-----	1
C 3	9J2358	PIN-----	1

C INDICATES CHANGE

202134

8J4954 TIP GROUP—Extreme Service  
Part of 9J2747 Tooth Group shown on Page 212A  
AN ATTACHMENT

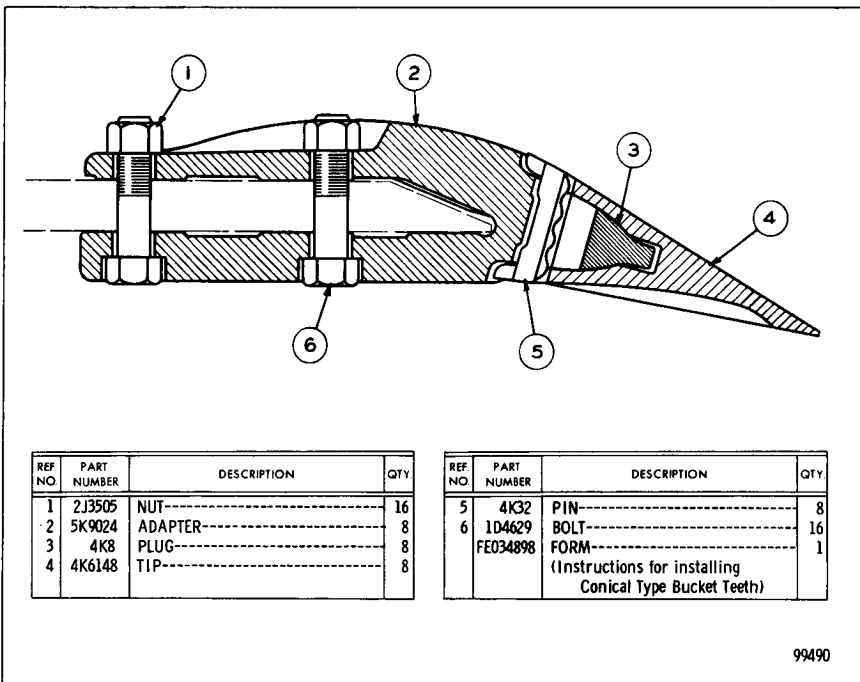

REF NO	PART NUMBER	DESCRIPTION	QTY
1	2J3505	NUT-----	16
2	5K9024	ADAPTER-----	8
3	4K8	PLUG-----	8
4	4K6148	TIP-----	8

REF NO	PART NUMBER	DESCRIPTION	QTY
5	4K32	PIN-----	8
6	1D4629	BOLT-----	16
	FE034898	FORM-----	1
(Instructions for installing Conical Type Bucket Teeth)			

99490

5K9022 TOOTH GROUP—Long Tip  
FOR USE WITH GENERAL PURPOSE AND LOOSE MATERIAL BUCKETS  
AN ATTACHMENT

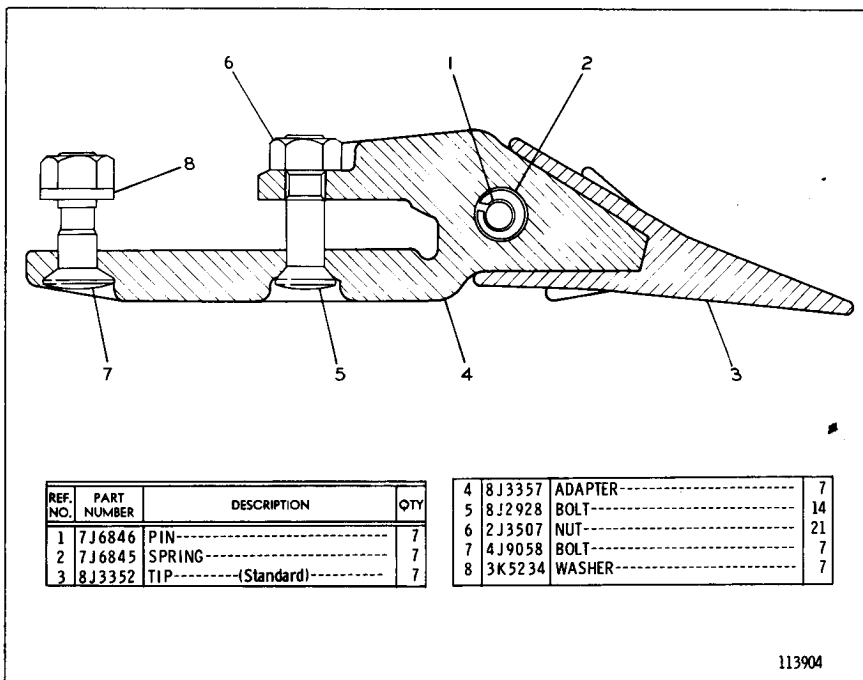

REF. NO.	PART NUMBER	DESCRIPTION	QTY
1	7J6846	PIN-----	7
2	7J6845	SPRING-----	7
3	8J3352	TIP----- (Standard)	7

4	8J3357	ADAPTER-----	7
5	8J2928	BOLT-----	14
6	2J3507	NUT-----	21
7	4J9058	BOLT-----	7
8	3K5234	WASHER-----	7

113904

8J3247 TOOTH GROUP—Long Tip  
FOR USE WITH GENERAL PURPOSE AND LOOSE MATERIAL BUCKETS  
Only separate parts serviced. When complete Group is required, order  
9J2746 shown on Page 218A. AN ATTACHMENT

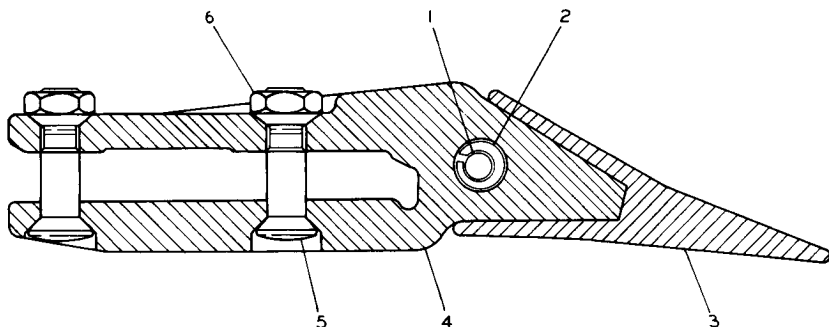

REF. NO.	PART NUMBER	DESCRIPTION	QTY
1	9J2358	PIN-----	1
2	716845	SPRING-----	1
3	8J3352	TIP----- (standard)-----	1
4	9J2357	ADAPTER-----	1
5	8J2928	BOLT-----	3
6	8J2933	NUT-----	3

148655

9J2746 TOOTH GROUP—Long Tip—7 Required  
FOR USE WITH 8K9500 AND 8K9501 BUCKET ASSEMBLIES  
AN ATTACHMENT

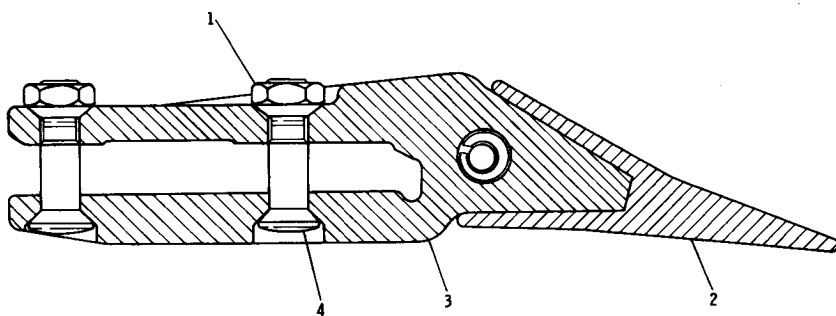

REF. NO.	PART NUMBER	DESCRIPTION	QTY
1	8J2933	NUT-----	3
2	8J4955	TIP GROUP----- (Separate Illustration)	1
3	9J2357	ADAPTER-----	1
4	8J2928	BOLT-----	3

149596

9J2746 TOOTH GROUP—Long Tip—7 Required—Type 2  
FOR USE WITH 8K9500 AND 8K9501 BUCKET ASSEMBLIES  
AN ATTACHMENT

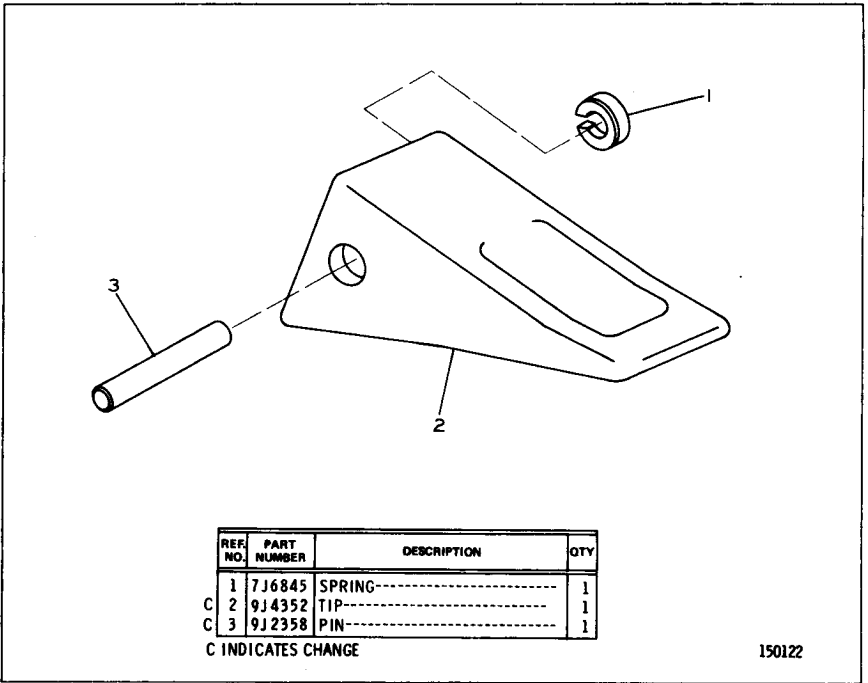

8J4955 TIP GROUP—Standard  
Part of 9J2746 Tooth Group  
AN ATTACHMENT

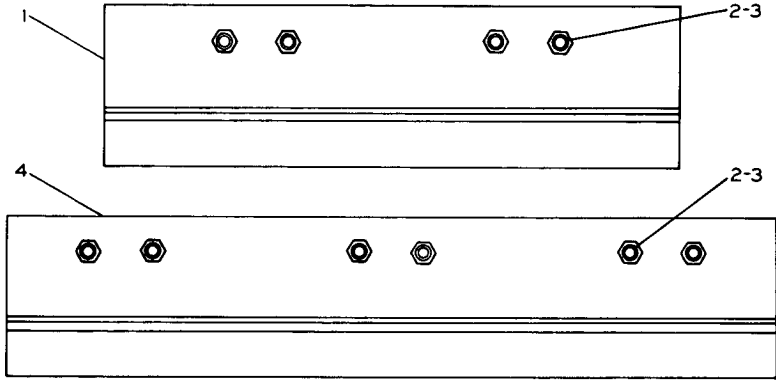

REF. NO.	PART NUMBER	DESCRIPTION	QTY
1	8 J9068	CUTTING EDGE----(End)-----	2
2	1 J5607	BOLT-----	14

3	2 J3507	NUT-----	14
4	8 J9059	CUTTING EDGE----(Center)-----	1

117060

8J9062 CUTTING EDGE—Field Installation  
 FOR USE WITH 8K9501 GENERAL PURPOSE BUCKET GROUP & 8K9500  
 BUCKET GROUP SHOWN ON PAGES 203 & 204. CANNOT BE USED  
 WITH 8J3354 ADAPTERS

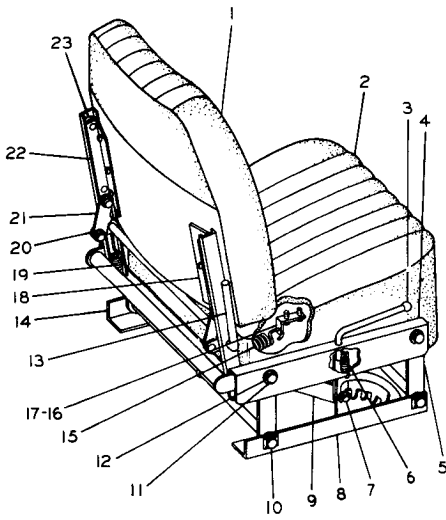

REF. NO.	PART NUMBER	DESCRIPTION	QTY
1	755387	CUSHION ASSEM.-----	1
2	755390	CUSHION ASSEM.-----	1
3	755380	KNOB-----	1
4	755391	FRAME ASSEM.-----	1
	755750	FRAME ASSEM.-----	1
5	755753	LEVER ASSEM.-----	2
6	755758	SPRING-----	1
7	1883	WASHER-----	2
	755757	RING-----	2
8	755751	ANGLE ASSEM.-----(R. H.)-----	1
9	755754	LEVER ASSEM.-----	1
10	755759	NUT-----	4
11	755755	PIN-----	4
12	2R364	RING-----	8
13	755385	LINK ASSEM.-----	1
14	755752	ANGLE ASSEM.-----(L. H.)-----	1
15	755388	SPRING-----	1
16	755389	BRACKET-----	1
17	2K7115	SCREW-----	12
	4F2293	LOCKWASHER-----	12
18	755381	BRACKET ASSEM.-----(R. H.)-----	1
19	755383	SPRING-----	2
20	755757	RING-----	4
21	755384	LINK-----	2
22	755382	BRACKET ASSEM.-----(L. H.)-----	1
	755386	ROLLER-----	4
23	7F3494	WASHER-----	2

113556

5S45 SEAT ASSEMBLY  
 Part of Seat Cushion and Frame shown on Pages 217, 219 and 221





CONSISTS OF:		PAGE
1	2P4867 FLOOR PLATE GROUP.....	224A
1	3P2655 SUPPORT AND SEAT GROUP.....	223A
2	3B4506 LOCKWASHER--3/8" --STRIP AND BARRIER TO FIREWALL	
1	5B7267 CORK--To TRANSMISSION CONTROL CONSOLE	
2	2P4896 STRIP--To FIREWALL	
1	2P4897 BARRIER--To FIREWALL	
1	3P7973 COVER ASSEMBLY--To INSTRUMENT PANEL	
CONSISTS OF:		
1	8S971 COVER	
8 DM.	5P814 SEAL	
1	3P8274 FUEL TANK ASSEMBLY	
CONSISTS OF:		
1	3P3533 COVER	
1	2P1533 TANK ASSEMBLY	
CONSISTING OF:		
1	8H3496 FITTING	
1	1L5784 FITTING	
1	7M5007 FITTING	
1	3P9728 GRAB IRON--HYDRAULIC CONSOLE TO FLOORPLATE	
1	3P9733 GUARD ASSEMBLY--TRANSMISSION CONSOLE TO BATTERY BOX	
2	S1594 BOLT--STRIP AND BARRIER TO FIREWALL	

## 3P6148 SOUND SUPPRESSION INSTALLATION ARRANGEMENT—

Factory Installation

FOR USE WITH 3P5982 ROLL-OVER PROTECTIVE SYSTEM SHOWN ON PAGE 248A  
AN ATTACHMENT

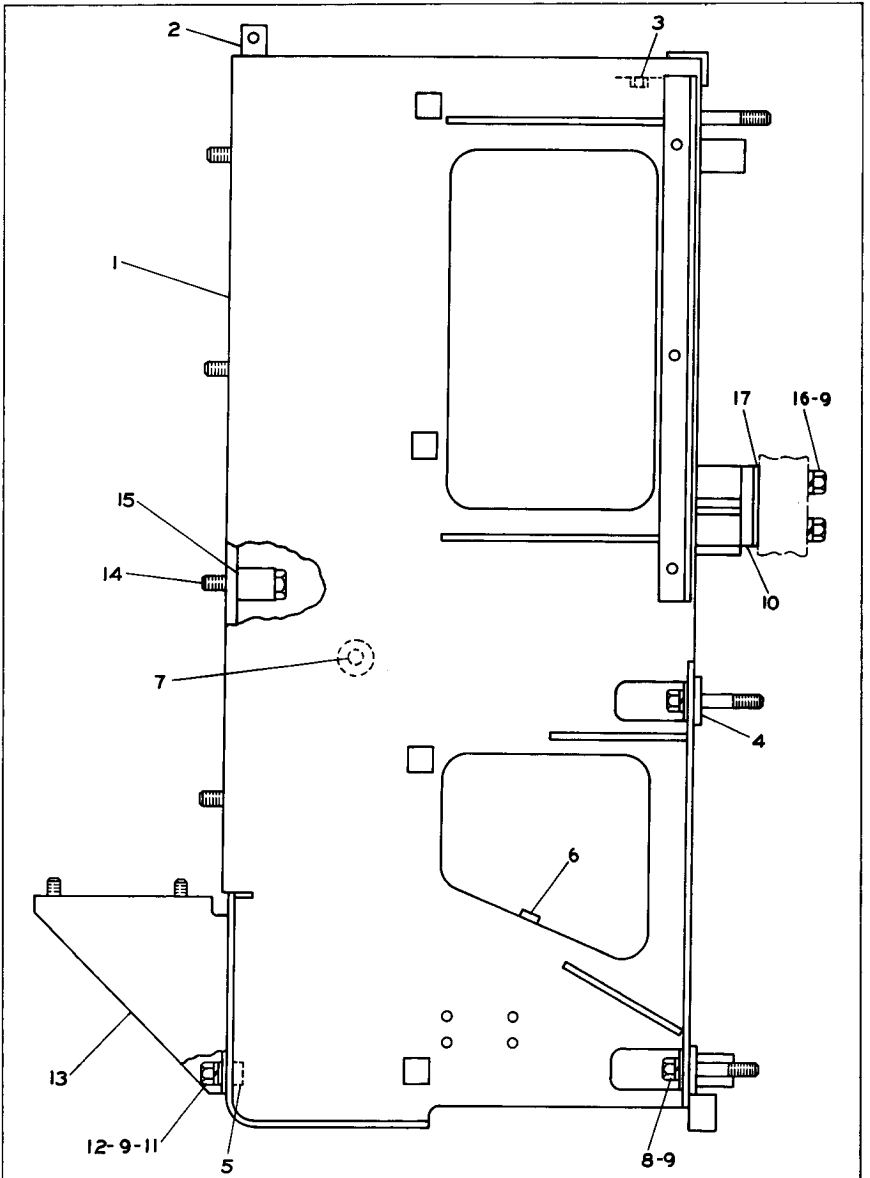

REF. NO.	PART NUMBER	DESCRIPTION	QTY
1	8S8766	SUPPORT ASSEM.-----	1
2	6B7697	PLATE-----	10
3	9F2978	NUT----- (Weld)-----	11
4	4M6013	WASHER-----	4
5	1F748	NUT----- (Weld)-----	12
6	5M3012	LUG-----	4
7	3R451	BOSS-----	1

8	V375	BOLT-----	6
9	3B4508	LOCKWASHER-----	16
10	4S7995	SPACER-----	1
11	7B3235	BOLT-----	8
12	3H7654	WASHER-----	8
13	9S3931	BRACKET-----	2
14	1A8537	BOLT-----	8
15	7S3885	SPACER-----	8
16	1D4566	BOLT-----	2
17	5S59	SHIMPACK----- (10 Pieces)-----	1

113174

FUEL TANK, HYDRAULIC TANK AND SEAT SUPPORTS (3S2032 N/S)—Top View

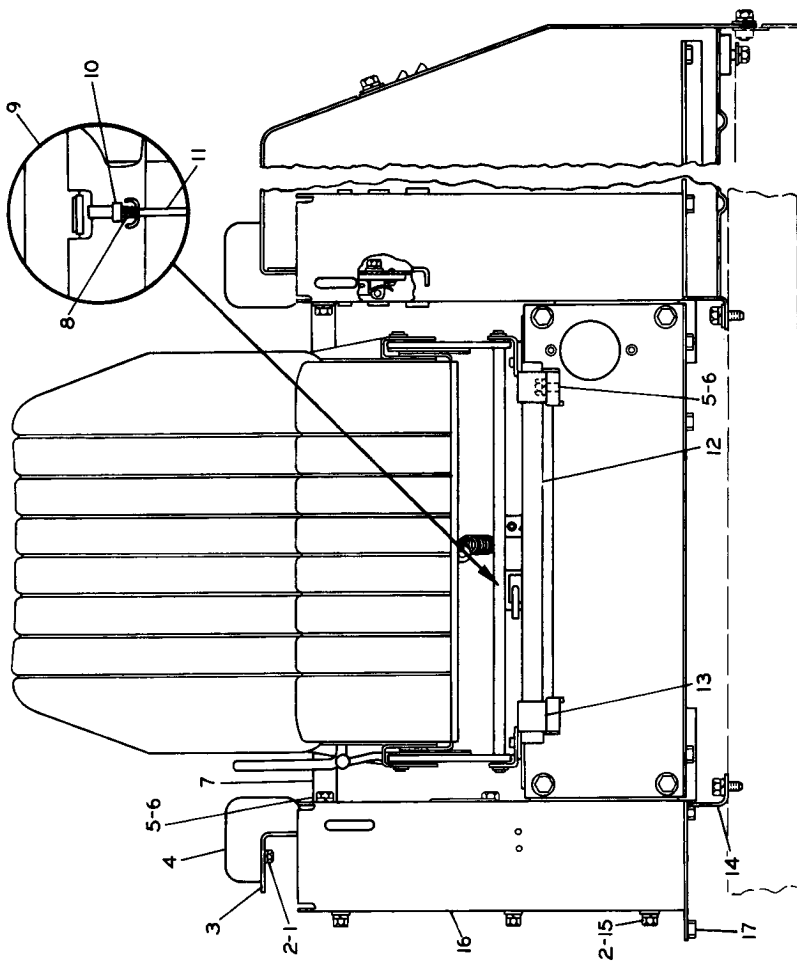

REF. NO.	PART NUMBER	DESCRIPTION	QTY
1	L472	BOLT	4
2	3B4506	LOCKWASHER	11
3	{4S5037 1F748}	SUPPORT ASSEM.	1
		NUT	3
4	5H2028	(Part of 4S5037 Assem.)	2
5	2H3955	CUSHION ASSEM.	8
6	3B4508	LOCKWASHER	10
7	4S5033	BRACKET	1
8	8B3090	SPRING	1
9	3S6078	PLATE ASSEM.	1
10	{7M5182 9F7882}	BLOCK	1
		PIN	1
11	7M5181	ROD	1
12	{9S9645 L1351}	HINGE ASSEM.	1
		BOLT	4
		SEAL	1
13	1S1476	CLIP	2
14	{1P977 1F748 9F2978}	PLATE ASSEM. (Right Hand)	1
		NUT	6
		NUT	2
15	{S509 4B4278 3S5668}	(Parts of 1P977 Assem.)	3
		BOLT	3
		WASHER	1
16	{9F2978 9F6445}	GUARD ASSEM.	2
		NUT	2
17	{1F748 9F2978}	(Parts of 3S5668 Assem.)	5
		NUT	4

110734

SEAT CUSHION AND FRAME (3S4619 N/S)—Part 1  
 Serial No. 11K5051 to 11K5262 inclusive  
 Note: 6D4709 Seat Belt Assembly is available

SEAT CUSHION AND FRAME (3S4619 N/S)—Part 2  
 Serial No. 11K5051 to 11K5262 inclusive  
 5S45 Seat parts are shown on Page 214

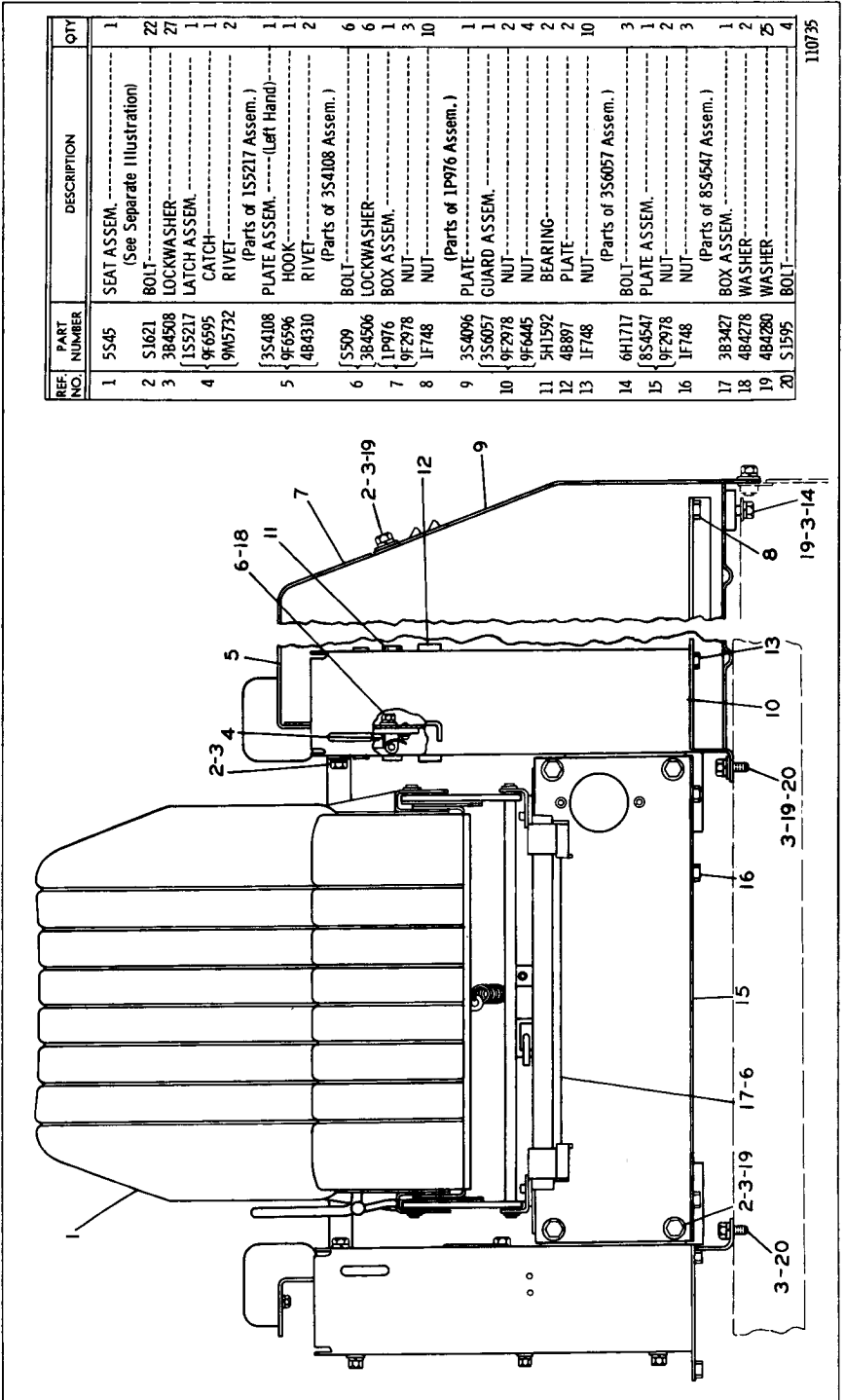

REF. NO.	PART NUMBER	DESCRIPTION	QTY
1	5S45	SEAT ASSEM. (See Separate Illustration)	1
2	S1621	BOLT	22
3	3B4508	LOCKWASHER	27
	1S5217	LATCH ASSEM.	1
4	9F6595	CATCH	1
	9M5732	RIVET	2
	3S4108	(Parts of 1S5217 Assem.)	1
5	9F6596	PLATE ASSEM. (Left Hand)	1
	4B4310	HOOK	1
		RIVET	2
	S509	(Parts of 3S4108 Assem.)	6
6	3B4506	BOLT	6
	1P976	LOCKWASHER	6
7	9F2978	BOX ASSEM.	1
	1F748	NUT	3
8		NUT	10
	3S4096	(Parts of 1P976 Assem.)	1
9	3S6057	PLATE	1
	9F2978	GUARD ASSEM.	1
10	9F6445	NUT	2
	5H1592	NUT	4
11	4B897	BEARING	2
12	1F748	PLATE	2
13		NUT	10
	6H1717	(Parts of 3S6057 Assem.)	3
14	8S4547	BOLT	3
15	9F2978	PLATE ASSEM.	1
	1F748	NUT	2
16		NUT	3
	3B3427	(Parts of 8S4547 Assem.)	1
17	4B4278	BOX ASSEM.	1
18	4B4280	WASHER	2
19	S1595	WASHER	2
20		BOLT	4

110735

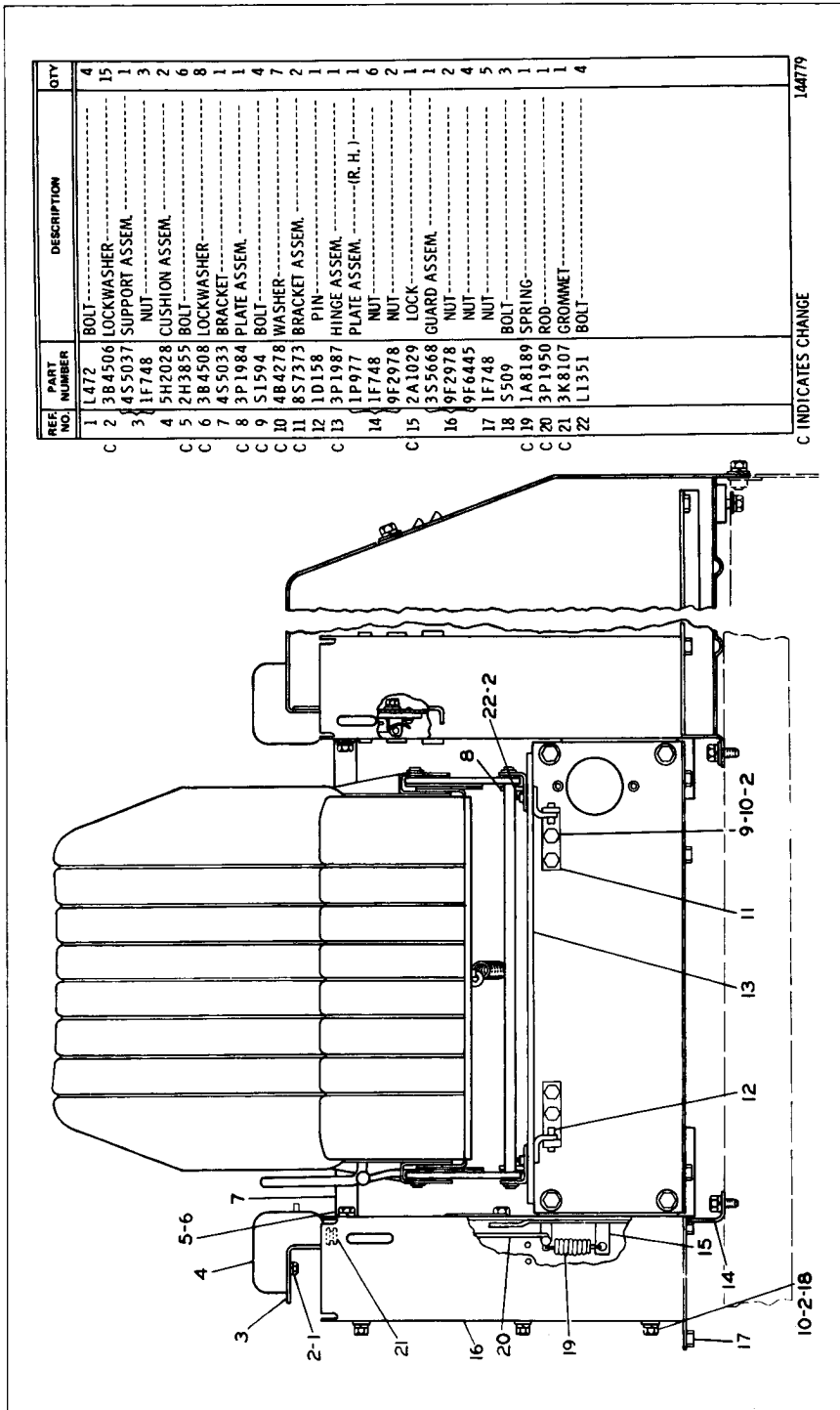

REF. NO.	PART NUMBER	DESCRIPTION	QTY
1	L472	BOLT	4
2	3B4506	LOCKWASHER	15
3	4S5037	SUPPORT ASSEM.	1
4	1F748	NUT	3
5	5H2028	CUSHION ASSEM.	2
6	52H3855	BOLT	6
7	3B4508	LOCKWASHER	8
8	4S5033	BRACKET	1
9	3P1984	PLATE ASSEM.	1
10	51594	BOLT	4
11	4B4278	WASHER	7
12	8S7373	BRACKET ASSEM.	2
13	1D158	PIN	1
14	3P1987	HINGE ASSEM.	1
15	1P977	PLATE ASSEM. (R. H.)	1
16	1F748	NUT	6
17	9F2978	NUT	2
18	2A1029	LOCK	1
19	3S5668	GUARD ASSEM.	1
20	9F2978	NUT	2
21	9F6445	NUT	4
22	1F748	NUT	5
	5509	BOLT	3
	1A8189	SPRING	3
	3P1950	ROD	1
	3K8107	GROMMET	1
	L1351	BOLT	1
			4

C INDICATES CHANGE 144779

SEAT CUSHION AND FRAME (3S4619 N/S)—Part 1

Serial No. 11K5263 to 11K5416 inclusive

Note: 6D4709 Seat Belt Assembly is available

SEAT CUSHION AND FRAME (3S4619 N/S)—Part 2  
 Serial No. 11K5263 to 11K5416 inclusive  
 5S45 Seat parts are shown on Page 214

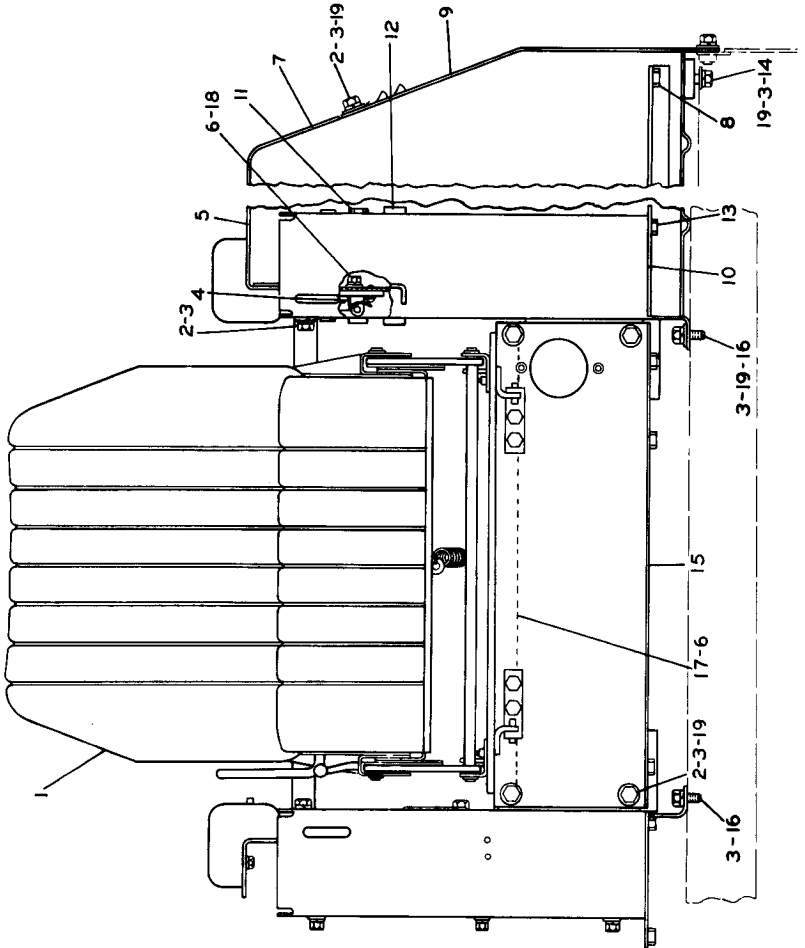

REF. NO.	PART NUMBER	DESCRIPTION	QTY
1	5S45	SEAT ASSEM. (Separate Illustration)	1
C 2	51621	BOLT	20
C 3	384508	LOCKWASHER	25
	155217	LATCH ASSEM.	1
4	9F6595	CATCH	1
	9M5732	RIVET	2
5	3S4108	PLATE ASSEM. (L.H.)	1
	9F6596	HOOK	1
	4B4310	RIVET	2
6	5S09	BOLT	6
	384506	LOCKWASHER	6
7	1P976	BOX ASSEM.	1
	9F2978	NUT	3
8	1F748	NUT	10
9	3S4096	PLATE	1
	3S6057	GUARD ASSEM.	1
10	9F2978	NUT	2
	9F6445	NUT	4
11	5H1592	BEARING	2
12	4B897	PLATE	2
13	1F748	NUT	10
14	6H1717	BOLT	3
C 15	3P1986	PLATE ASSEM.	1
16	51595	BOLT	4
17	3B3427	BOX ASSEM.	1
18	4B4278	WASHER	2
C 19	4B4280	WASHER	23

C INDICATES CHANGE

144780

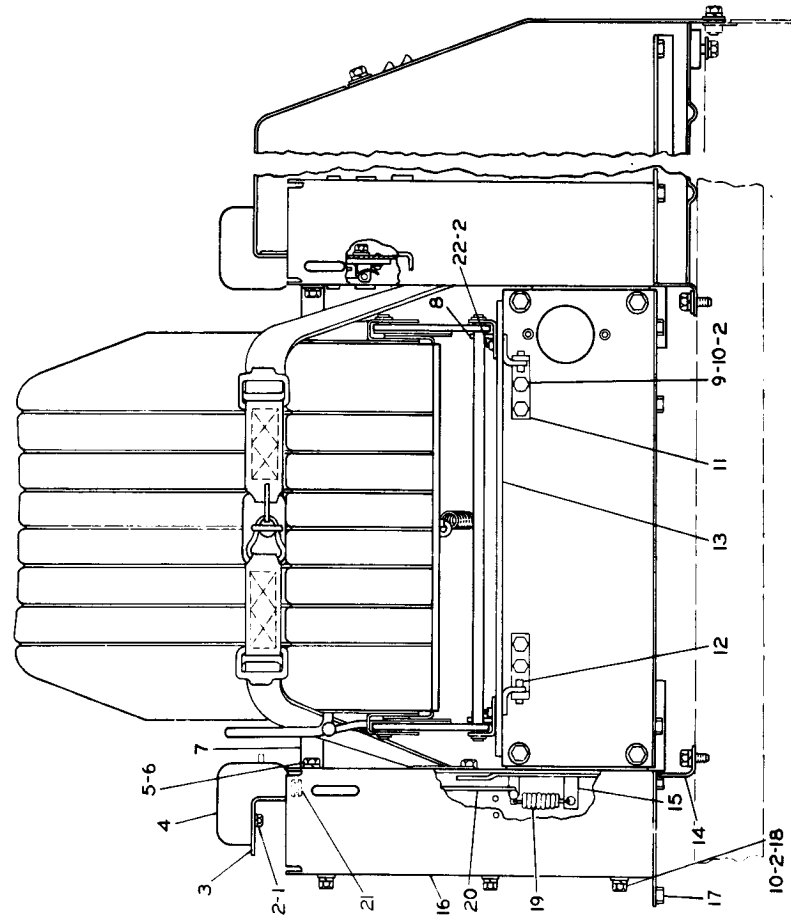

REF. NO.	PART NUMBER	DESCRIPTION	QTY
1	L472	BOLT	4
2	3B4506	LOCKWASHER	15
3	4S5037	SUPPORT ASSEM.	1
4	1F748	NUT	3
5	5H2028	CUSHION ASSEM.	2
6	2H3855	BOLT	6
7	3B4508	LOCKWASHER	8
8	4S5033	BRACKET	1
9	3P1984	PLATE ASSEM.	1
10	S1594	BOLT	4
11	4B4278	WASHER	7
12	8S7373	BRACKET ASSEM.	2
13	1D158	PIN	1
14	3P1987	HINGE ASSEM.	1
15	1P977	PLATE ASSEM. (R.H.)	1
16	1F748	NUT	6
17	9F2978	NUT	2
18	2A1029	LOCK	1
19	3S5668	GUARD ASSEM.	1
20	9F2978	NUT	2
21	9F6445	NUT	4
22	1F748	NUT	5
	S509	BOLT	3
	1A8189	SPRING	1
	3P1950	ROD	1
	3K8107	GROMMET	1
	L1351	BOLT	4

145384

SEAT CUSHION AND FRAME (3S4619 N/S)—Part 1  
 Serial No. 11K5417 to 11K6339 inclusive



SEAT CUSHION AND FRAME (3S4619 N/S)—Part 2  
 Serial No. 11K5417 to 11K6339 Inclusive  
 5S45 Seat parts are shown on Page 214

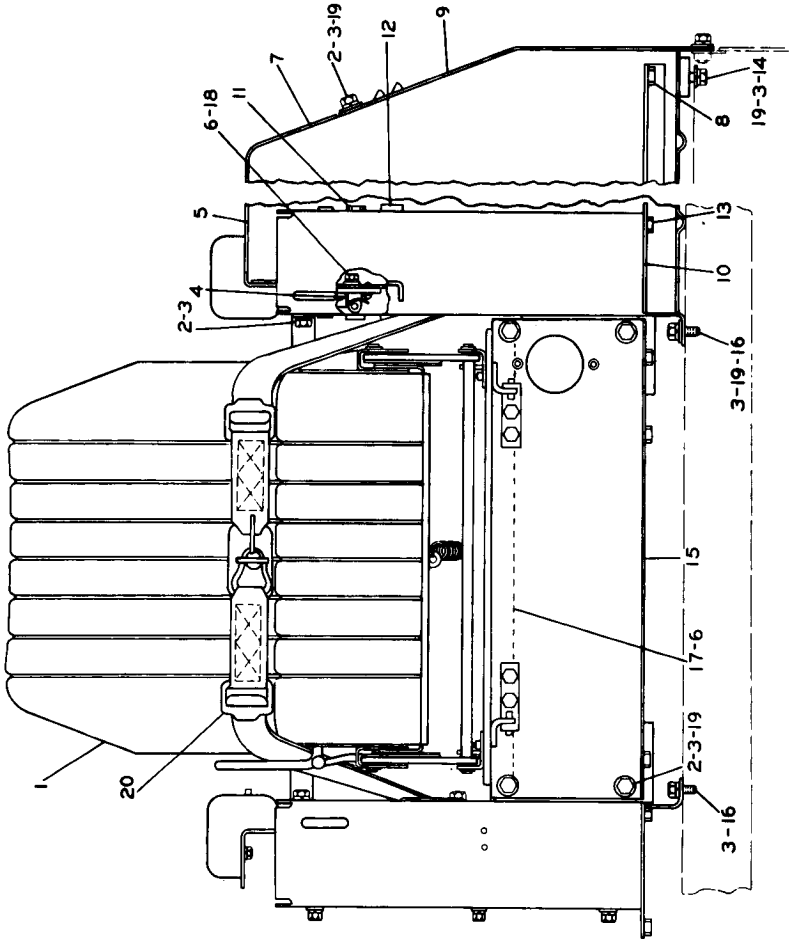

REF. NO.	PART NUMBER	DESCRIPTION	QTY.
1	5S45	SEAT ASSEM. ....	1
2	S1621	BOLT.....	20
3	3B4508	LOCKWASHER.....	25
4	1S5217	LATCH ASSEM. ....	1
5	9F6595	CATCH.....	1
6	9M5732	RIVET.....	2
7	3S4108	PLATE ASSEM. .... (L. H.)	1
8	9F6596	HOOK.....	1
9	4B4310	RIVET.....	2
10	S509	BOLT.....	6
11	3B4506	LOCKWASHER.....	6
12	1P976	BOX ASSEM. .... (battery)	1
13	9F2978	NUT.....	3
14	1F748	NUT.....	10
15	3S4096	PLATE.....	1
16	3S6057	GUARD ASSEM. ....	1
17	9F2978	NUT.....	2
18	9F6445	NUT.....	4
19	5H1592	BEARING.....	2
20	4B897	PLATE.....	2
21	1F748	NUT.....	10
22	6H1717	BOLT.....	3
23	3P1986	PLATE ASSEM. ....	1
24	S1595	BOLT.....	4
25	3B3427	BOX ASSEM. .... (tool)	1
26	4B4278	WASHER.....	2
27	4B4280	WASHER.....	2
28	6D4709	SEAT BELT ASSEM. ....	1

C INDICATES CHANGE

145385

REF. NO.	PART NUMBER	DESCRIPTION	QTY.
1	1472	BOLT	4
2	384506	LOCKWASHER	15
3	455037	SUPPORT ASSEM.	1
4	1F748	NUT	3
4	15H2028	CUSHION ASSEM.	2
5	2H3855	BOLT	6
6	384508	LOCKWASHER	8
7	455033	BRACKET	1
8	3P1984	PLATE ASSEM.	1
9	1S1594	BOLT	4
10	4B4278	WASHER	7
11	857373	BRACKET ASSEM.	2
12	1D1158	PIN	1
13	3P1987	HINGE ASSEM.	1
13	1P977	PLATE ASSEM. (R. H.)	1
14	1F748	NUT	6
14	9F2978	NUT	2
15	2A1029	LOCK	1
16	6P2471	GUARD ASSEM.	1
17	1L1351	BOLT	4
18	1S509	BOLT	3
19	1A8189	SPRING	1
20	3P1950	ROD	1
21	3K8107	GROMMET	1

C INDICATES CHANGE  
151499

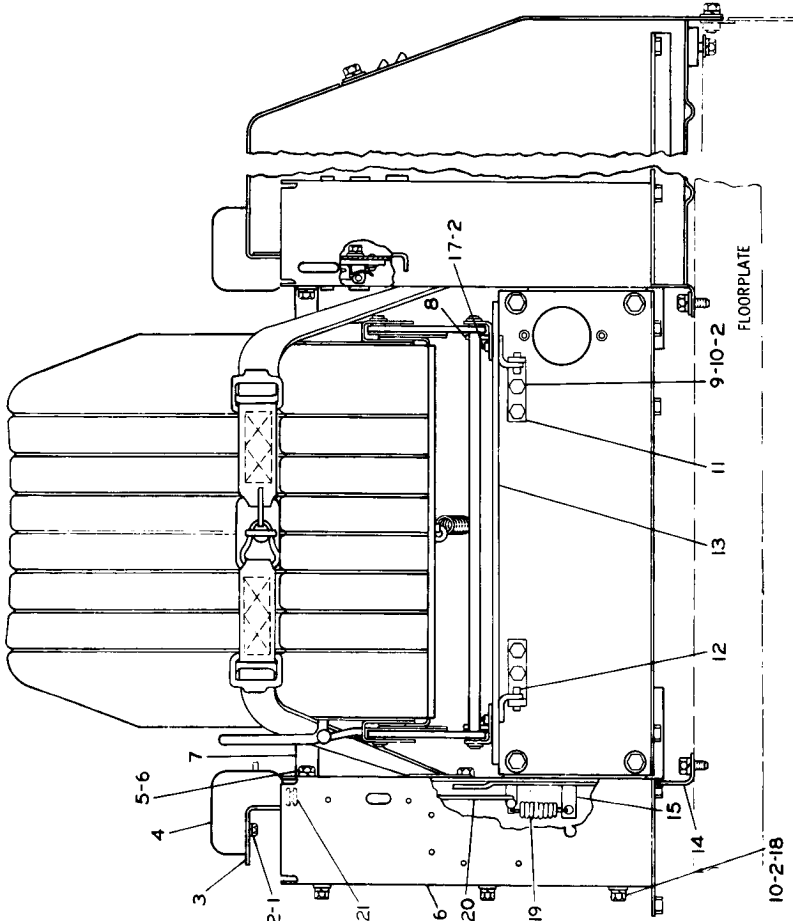

SEAT CUSHION AND FRAME (3S4619 N/S)—Part 1  
Serial No. 11K6340—Up

SEAT CUSHION AND FRAME (3S4619 N/S)—Part 2  
 Serial No. 11K6340—Up. 5S45 Seat parts are shown on Page 214

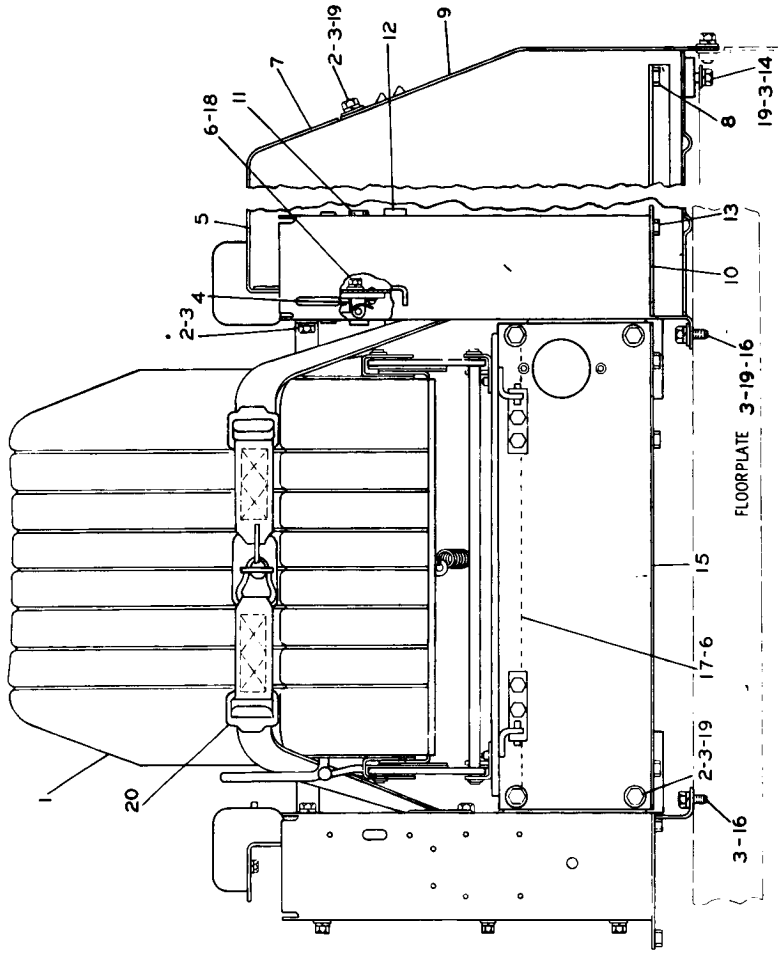

REF. NO.	PART NUMBER	DESCRIPTION	QTY
1	5S45	SEAT ASSEM. (Separate Illustration)	1
2	S1621	BOLT	20
3	3B4508	LOCKWASHER	25
4	1S5217	LATCH ASSEM.	1
5	9F6595	CATCH	2
6	9M5732	RIVET	1
7	3S4108	PLATE ASSEM. (L. H.)	1
8	9F6596	HOOK	1
9	4B4310	RIVET	2
10	S509	BOLT	6
11	3B4506	LOCKWASHER	6
12	1P976	BOX ASSEM. (battery)	1
13	9F2978	NUT	3
14	1F748	NUT	10
15	3S4096	PLATE	1
16	3S6057	GUARD ASSEM.	1
17	9F2978	NUT	2
18	9F6445	BEARING	2
19	5H1592	BEARING	4
20	4B897	PLATE	2
21	1F748	NUT	10
22	6H1717	BOLT	3
23	3P1986	PLATE ASSEM.	1
24	S1595	BOLT	4
25	3B3427	BOX ASSEM. (tool)	1
26	4B4278	WASHER	2
27	4B4280	WASHER	25
28	6D4709	SEAT BELT ASSEM.	1

151500

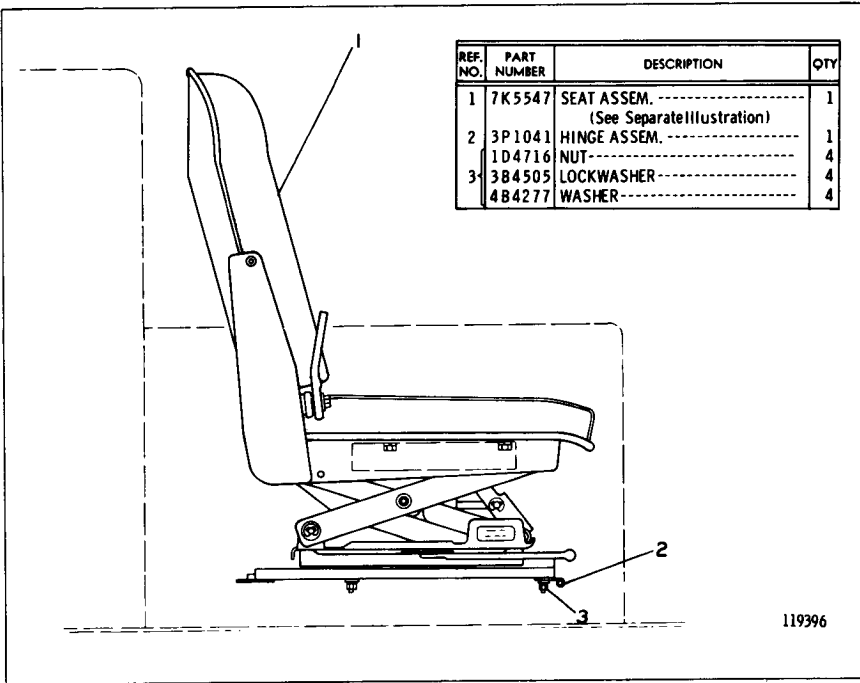

2P2643 ADJUSTABLE SEAT GROUP—Type 1  
AN ATTACHMENT

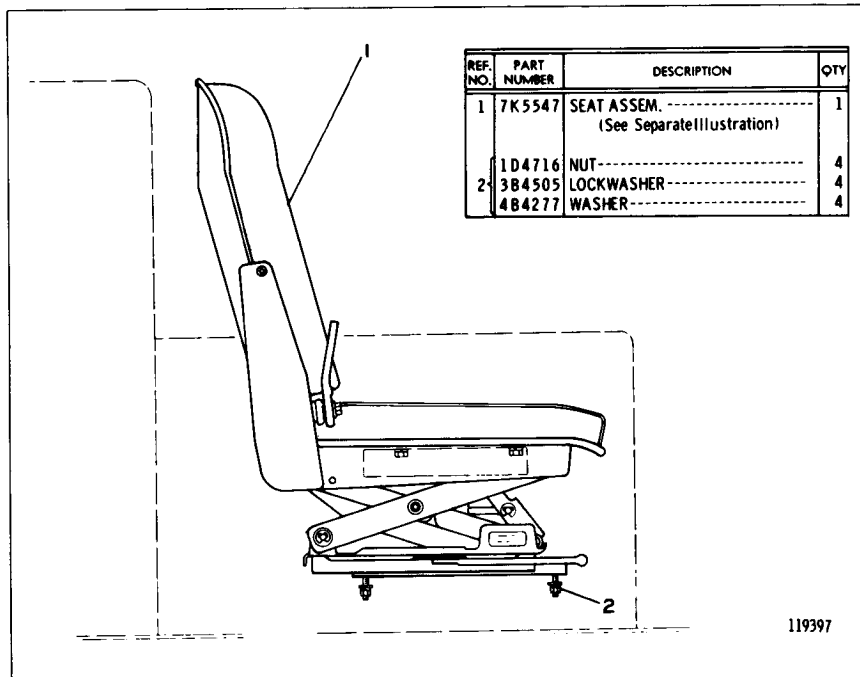

2P2643 ADJUSTABLE SEAT GROUP—Type 2  
AN ATTACHMENT

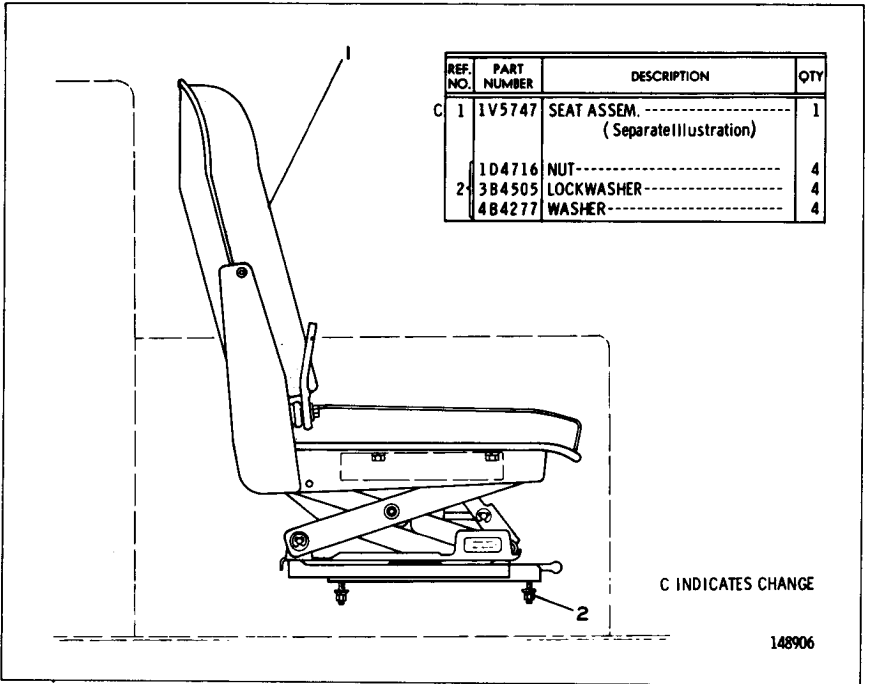

2P2643 ADJUSTABLE SEAT GROUP—Type 3  
 1V5747 Seat Parts are shown on Page 222B  
 AN ATTACHMENT

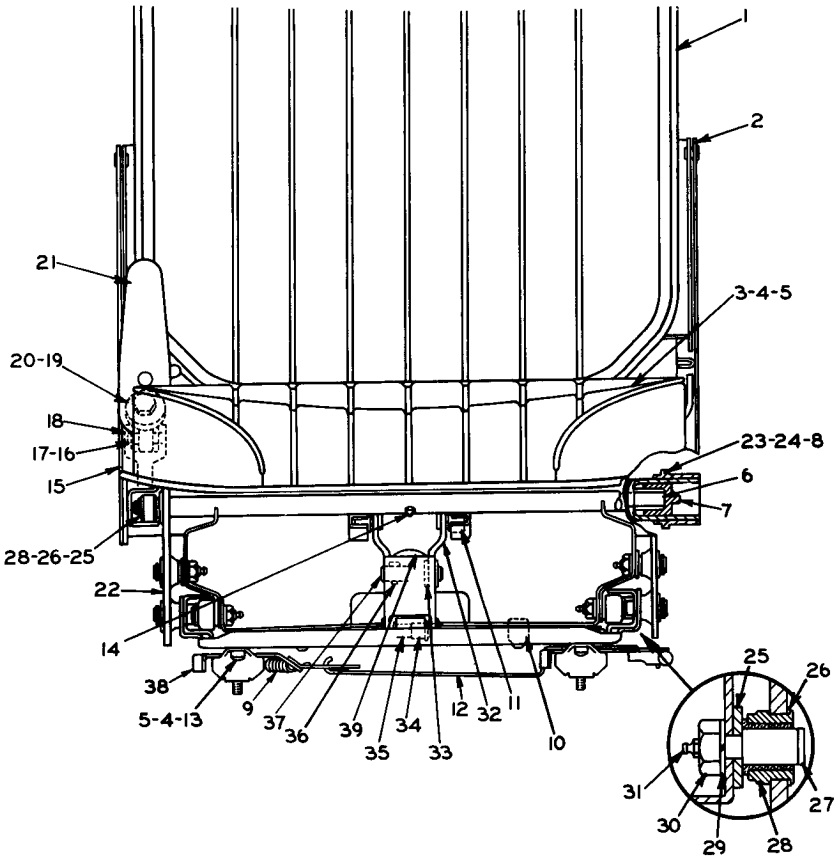

REF. NO.	PART NUMBER	DESCRIPTION	QTY
1	8S168	CUSHION ASSEM.-----	1
2	7K9772	PANEL ASSEM.----- (L. H.)-----	1
3	7S7791	CUSHION ASSEM.-----	1
4	4B4277	WASHER-----	4
5	1D4716	NUT-----	8
6	3B4505	LOCKWASHER-----	12
7	7S9305	BAR SET-----	1
8	7S7805	RETAINER-----	1
9	7S7799	FITTING-----	2
9	7S4282	SPRING-----	2
10	7S7789	BUMPER-----	4
11	7S7793	BEARING-----	2
12	7K9770	WIRE-----	1
13	4B1328	SCREW-----	8
14	7S9868	FITTING-----	1
15	7K9771	PANEL ASSEM.----- (R. H.)-----	1
16	7S7801	PIN-----	1
17	7S7800	WASHER-----	1
18	7S7804	YOKE-----	1
19	7S9391	BEARING-----	1
20	7S7802	WASHER-----	1

21	7S9307	LEVER ASSEM.-----	1
22	7S9304	SUSPENSION ASSEM.-----	1
Consisting of:			
23	8S4346	BEARING----- (L. H.)-----	1
24	8S4345	BEARING----- (R. H.)-----	1
25	7S9884	WASHER-----	4
26	7S5757	RING-----	10
27	7S9867	STUD-----	6
28	7S9866	BEARING ASSEM.-----	4
29	3B4506	LOCKWASHER-----	6
30	1D4717	NUT-----	6
31	7S7799	FITTING-----	6
32	7S9873	BRACKET ASSEM.-----	1
33	7S9885	WASHER-----	2
34	7S9869	BEARING-----	2
35	7S9870	SHAFT-----	1
36	6H3956	PIN-----	2
37	7S9871	SHAFT-----	1
THE FOLLOWING REPAIR KITS ARE AVAILABLE:			
38	8K7223	KIT----- (Seat Adjuster)----- (Includes 2 Adjuster Asms. and Latch Wire)	1
39	7S4339	KIT----- (Shock Absorber Assem.)----- (Includes Shaft & Shock Absorber Assem.)	1

134793

7K5547 SEAT ASSEMBLY

Part of 2P2643 Adjustable Seat Group shown on Page 222. Note: 8K9002 Seat Belt is available. Only separate parts serviced. When complete Group is required, order 1V5747. AN ATTACHMENT

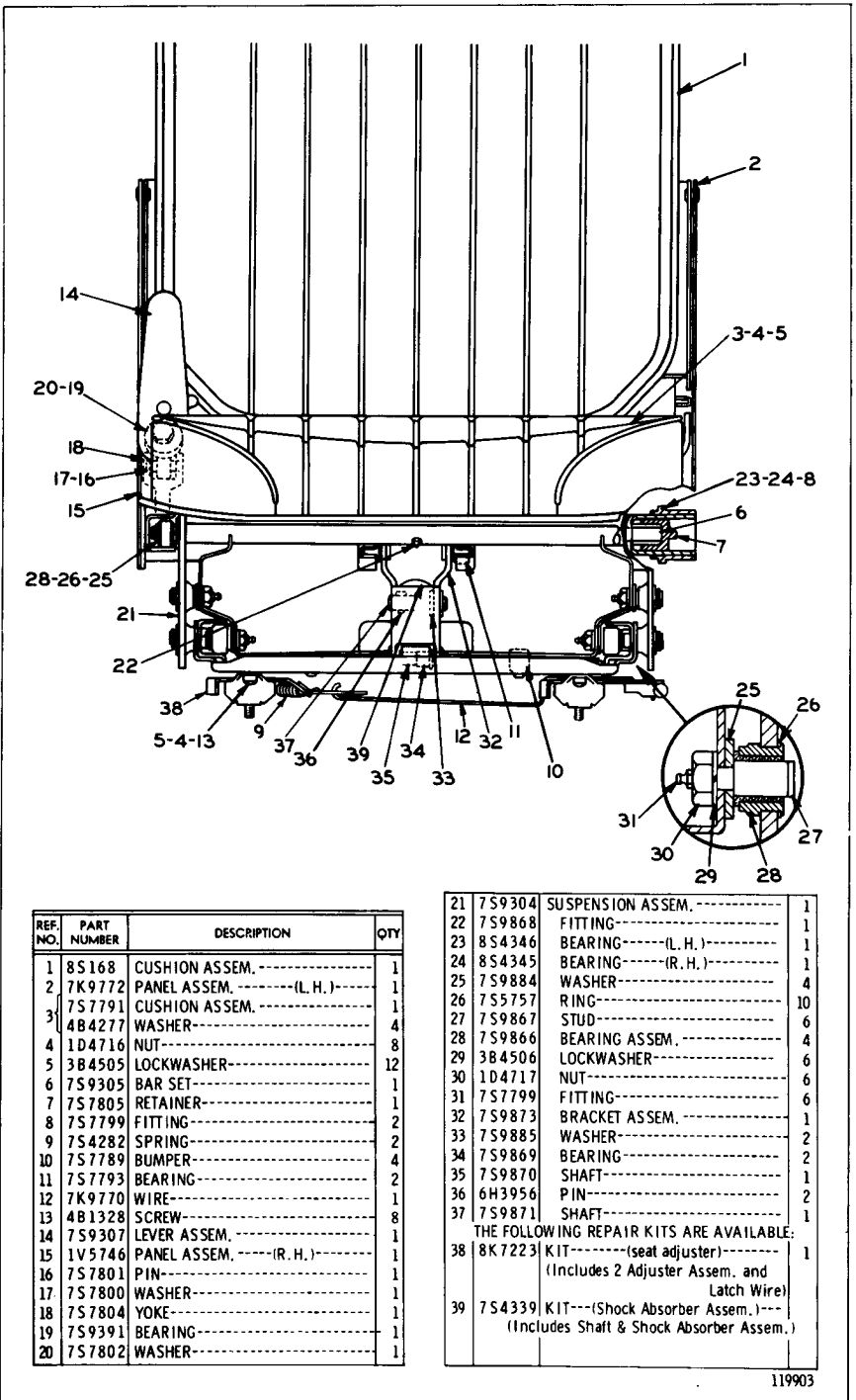

REF. NO.	PART NUMBER	DESCRIPTION	QTY
1	8S168	CUSHION ASSEM.-----	1
2	7K9772	PANEL ASSEM.----- (L. H.)	1
3	7S7791	CUSHION ASSEM.-----	1
4	4B4277	WASHER-----	4
5	1D4716	NUT-----	8
6	3B4505	LOCKWASHER-----	12
7	7S9305	BAR SET-----	1
8	7S7805	RETAINER-----	1
9	7S7799	FITTING-----	2
10	7S4282	SPRING-----	2
11	7S7789	BUMPER-----	4
12	7S7793	BEARING-----	2
13	7K9770	WIRE-----	1
14	4B1328	SCREW-----	8
15	7S9307	LEVER ASSEM.-----	1
16	1V5746	PANEL ASSEM.----- (R. H.)	1
17	7S7801	PIN-----	1
18	7S7800	WASHER-----	1
19	7S7804	YOKE-----	1
20	7S9391	BEARING-----	1
21	7S7802	WASHER-----	1

21	7S9304	SUSPENSION ASSEM.-----	1
22	7S9868	FITTING-----	1
23	8S4346	BEARING----- (L. H.)	1
24	8S4345	BEARING----- (R. H.)	1
25	7S9884	WASHER-----	4
26	7S5757	RING-----	10
27	7S9867	STUD-----	6
28	7S9866	BEARING ASSEM.-----	4
29	3B4506	LOCKWASHER-----	6
30	1D4717	NUT-----	6
31	7S7799	FITTING-----	6
32	7S9873	BRACKET ASSEM.-----	1
33	7S9885	WASHER-----	2
34	7S9869	BEARING-----	2
35	7S9870	SHAFT-----	1
36	6H3956	PIN-----	2
37	7S9871	SHAFT-----	1
THE FOLLOWING REPAIR KITS ARE AVAILABLE:			
38	8K7223	KIT----- (seat adjuster)	1
(Includes 2 Adjuster Assem. and Latch Wire)			
39	7S4339	KIT--- (Shock Absorber Assem.)	1
(Includes Shaft & Shock Absorber Assem.)			

119903

1V5747 SEAT ASSEMBLY  
 Part of 2P2643 Adjustable Seat Group shown on Page 222A  
 Note: 8K9002 Seat Belt is available. AN ATTACHMENT

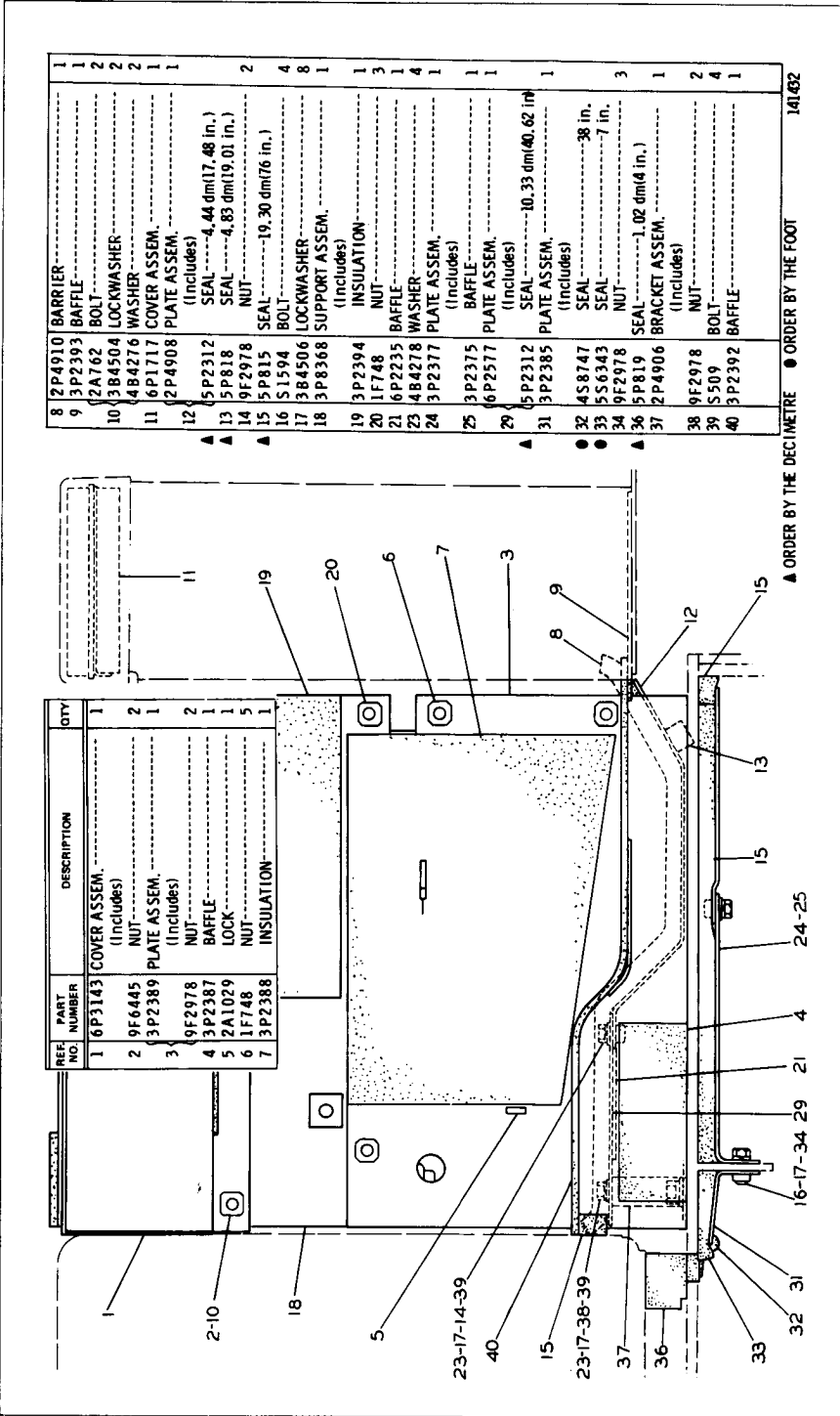

3P2655 SUPPORT AND SEAT GROUP—Part 1  
 Part of 3P6148 Sound Suppression Installation Arrangement listed on Page 214B  
 AN ATTACHMENT





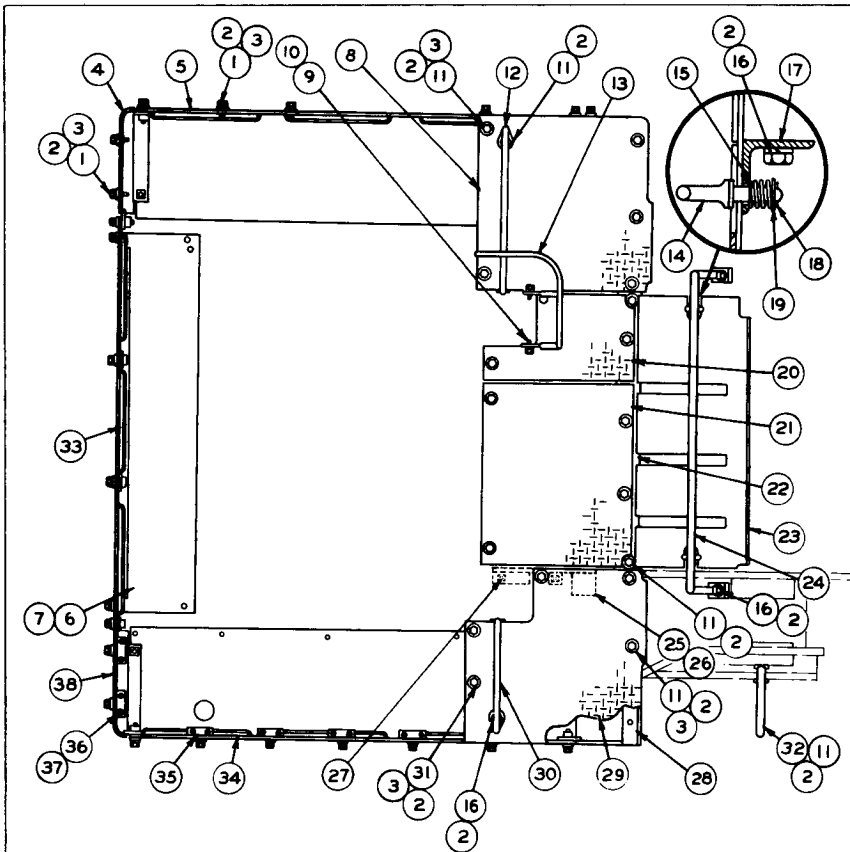

REF. NO.	PART NUMBER	DESCRIPTION	QTY
1	2H3855	BOLT-----	56
2	3B4508	LOCKWASHER-----	98
3	4B4280	WASHER-----	80
4	3S3936	GUARD ASSEM.-----(L. H.)-----	1
	1F748	NUT-----	5
5	3S5676	GUARD ASSEM.-----(L. H.)-----	1
6	3S3933	GUARD ASSEM.-----	1
7	1F748	NUT-----	4
8	3S5670	PLATE ASSEM.-----(L. H.)-----	1
	1F748	NUT-----	1
9	5509	BOLT-----	3
10	3B4506	LOCKWASHER-----	3
11	51621	BOLT-----	31
12	3S6103	GRAB IRON-----	1
13	4S9027	GUARD ASSEM.-----	1
14	9B1783	FASTENER-----	2
15	4B7033	SPRING-----	2
16	6H1717	BOLT-----	10
17	3S5391	ANGLE ASSEM.-----	2
	1F748	NUT-----	2
18	3B4623	COITER PIN-----	2
19	4B4278	WASHER-----	2
20	3S5380	PLATE-----	1
21	3S5388	PLATE-----	1
22	3S5385	PLATE ASSEM.-----	1
23	1F748	NUT-----	5
23	3S5386	PLATE ASSEM.-----	1

C 24	6P3106	GRAB IRON ASSEM.-----	1
25	8S8751	PLATE ASSEM.-----(R. H.)-----	1
26	8S8752	PLATE ASSEM.-----(L. H.)-----	1
27	1F748	NUT-----	2
		(Part of 8S8751 & 8S8752 Assem.)	
	3S5211	GUARD ASSEM.-----(R. H.)-----	1
	1F748	NUT---(-.50 in. Thread)-----	4
28	9F2978	NUT---(-.375 in. Thread)-----	2
	2P4140	GUARD ASSEM.-----(L. H.)-----	1
	1F748	NUT-----	4
29	3S5669	PLATE ASSEM.-----(R. H.)-----	1
	1F748	NUT-----	4
30	3S6073	GRAB IRON-----	1
31	1L329	BOLT-----	1
32	3S6074	GRAB IRON-----	2
33	3S3928	GUARD ASSEM.-----	1
C 34	3S5675	GUARD------(R. H.)-----	1
35	3S4584	BLOCK-----	6
36	1D4707	BOLT-----	12
37	3B4507	LOCKWASHER-----	12
38	3B3935	GUARD ASSEM.-----(R. H.)-----	1
	1F748	NUT-----	5

C INDICATES CHANGE

150881

FLOOR PLATES, GUARDS AND GRAB IRON (3S2031 N/S)

2P4867 FLOORPLATE GROUP  
 Part of 3P6148 Sound Suppression Installation Arrangement listed on Page 214B  
 AN ATTACHMENT

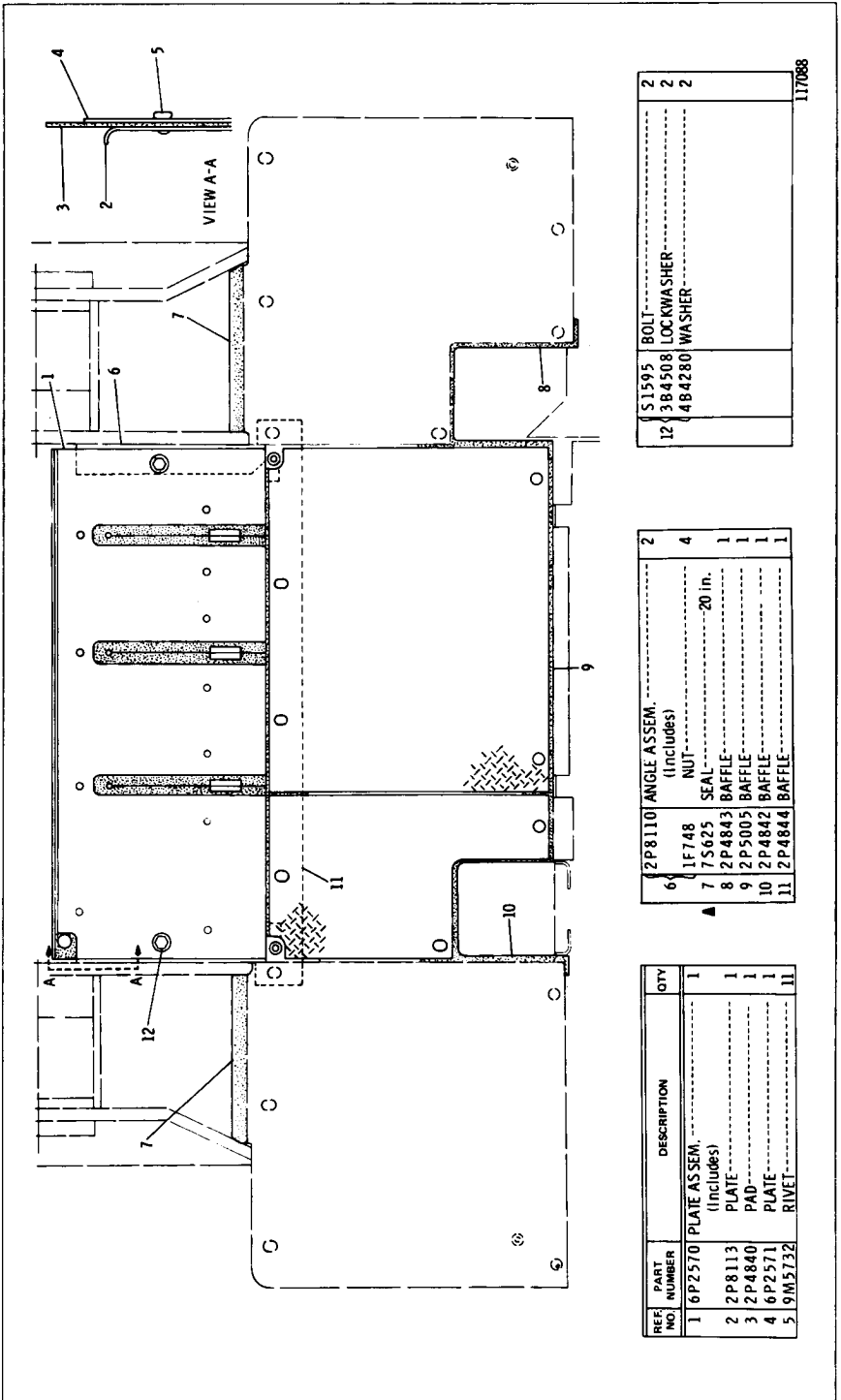

REF. NO.	PART NUMBER	DESCRIPTION	QTY
1	6P2570	PLATE ASSEM. (Includes)	1
2	2P8113	PLATE	1
3	2P4840	PAD	1
4	6P2571	PLATE	1
5	9M5132	RIVET	11

6	2P8110	ANGLE ASSEM. (Includes)	2
	1F748	NUT	4
7	7S625	SEAL	20 in.
8	2P4843	BAFFLE	1
9	2P5005	BAFFLE	1
10	2P4842	BAFFLE	1
11	2P4844	BAFFLE	1

12	1S1595	BOLT	2
	3R4508	LOCKWASHER	2
	4B4280	WASHER	2

117088

# CATERPILLAR 977L TRAXCAVATOR

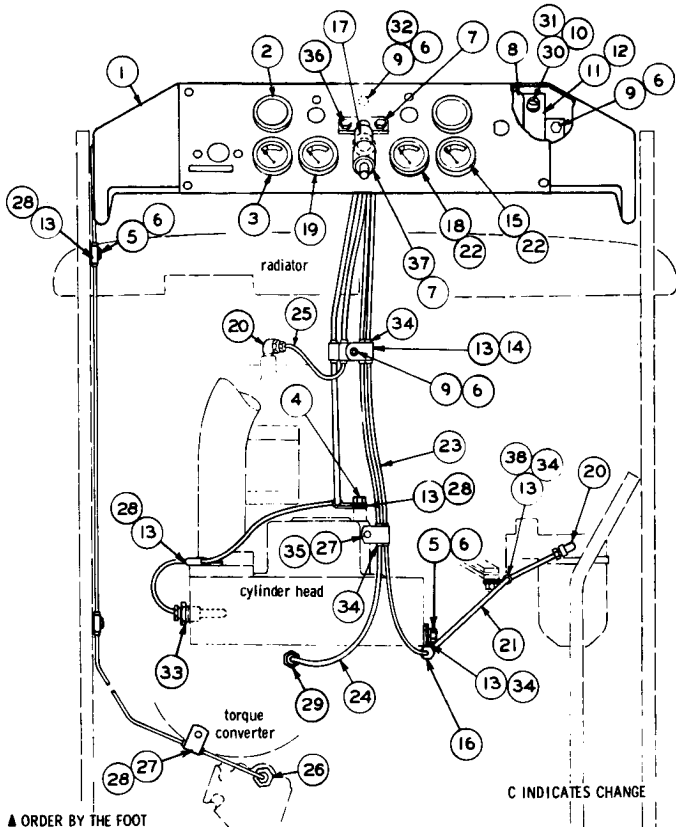

▲ ORDER BY THE FOOT  
● ORDER BY THE INCH

C INDICATES CHANGE

REF. NO.	PART NUMBER	DESCRIPTION	QTY
1	8S971	COVER	1
2	1L6377	BUTTON	1
3	1P5486	HEAT INDICATOR--(Converter)--	1
4	S1617	BOLT	2
5	S509	BOLT	3
6	3B4506	LOCKWASHER	9
7	1P6886	ADAPTER	1
8	1P7217	INLAY	1
9	L1351	BOLT	6
10	4K3533	WASHER	4
11	1P4888	PLATE ASSEM.	1
12	9F2978	NUT	4
13	9F6445	NUT	2
14	2B2404	CLIP--(Short)--	9
15	L2072	CLIP--(Long)--	2
16	1P5488	GAUGE--(Fuel Pressure)--	1
16	2D9885	FITTING	1
16	1F1344	NUT	1
17	9S9405	GROMMET--3 in.	1

18	1P5487	GAUGE--(Oil Pressure)--	1
19	9M2745	INDICATOR--(Water Temp.)--	1
20	8H6912	FITTING	2
C 21	4S8456	TUBE--(Copper)--38.48 in.	1
21	5K5805	FITTING	2
22	5K5804	NUT	1
22	5K5803	SLEEVE	1
C 23	4S8381	TUBE--(Nylon)--42 in.	1
C 24	4S8381	TUBE--(Nylon)--45 in.	1
C 25	4S8381	TUBE--(Nylon)--39 in.	1
26	5B1959	ADAPTER	1
26	2B5721	GASKET	1
27	6H3068	CLIP--(Short)--	2
28	8F244	GROMMET	7
29	3K6853	FITTING	1
29	3B6768	BUSHING	1
30	4B1330	SCREW	4
31	6J450	SHIM	4
32	4B4278	WASHER	1
33	6H6699	ADAPTER	1
34	3D5102	GROMMET	7
35	6H5506	CLIP--(Long)--	1
36	8M9937	BOLT	2
36	3K6116	WASHER	2
37	75687	INDICATOR	1
37	1M3010	FITTING	1
C 38	1D4716	NUT	1

119147

GAUGES AND INSTRUMENT PANEL (3S2028 N/S)  
Serial No. 11K5051 to 11K6041 inclusive

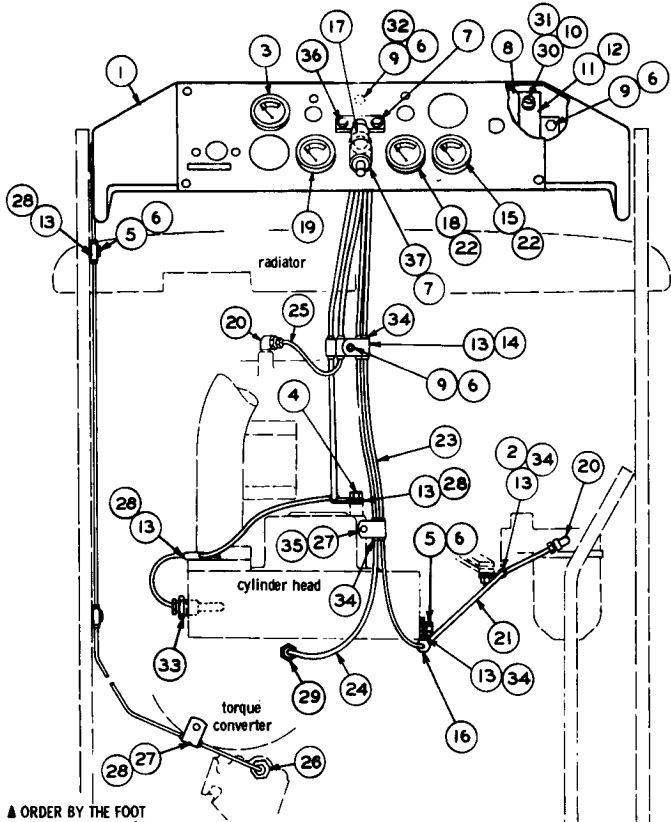

▲ ORDER BY THE FOOT  
● ORDER BY THE INCH

REF. NO.	PART NUMBER	DESCRIPTION	QTY
1	8S971	COVER-----	1
2	1D4716	NUT-----	1
3	1P5486	HEAT INDICATOR---(Converter)---	1
4	S1617	BOLT-----	2
5	S509	BOLT-----	3
6	3B4506	LOCKWASHER-----	9
7	1P6886	ADAPTER-----	1
8	1P7217	INLAY-----	1
9	L1351	BOLT-----	6
10	4K3533	WASHER-----	4
11	1P4888	PLATE ASSEM.-----	1
12	9F2978	NUT-----	4
13	9F6445	NUT-----	2
14	2B2404	CLIP----- (Short)	9
15	L2072	CLIP----- (Long)	2
16	1P5488	GAUGE----- (Fuel Pressure)---	1
15	2D9885	FITTING-----	1
16	1F1344	NUT-----	1
● 17	9S9405	GROMMET----- 3 in.	1

18	1P5487	GAUGE----- (Oil Pressure)---	1
19	9M2745	INDICATOR----- (Water Temp.)---	1
20	8H6912	FITTING-----	2
▲ 21	4S8456	TUBE----- (Copper)--- 38.48 in.	1
22	5K5805	FITTING-----	2
22	5K5804	NUT-----	1
22	5K5803	SLEEVE-----	1
▲ 23	4S8381	TUBE----- (Nylon)--- 42 in.	1
▲ 24	4S8381	TUBE----- (Nylon)--- 45 in.	1
▲ 25	4S8381	TUBE----- (Nylon)--- 39 in.	1
26	5B1959	ADAPTER-----	1
26	2B5721	GASKET-----	1
27	6H3068	CLIP----- (Short)	2
28	8F244	GROMMET-----	7
29	3K6853	FITTING-----	1
29	3B6768	BUSHING-----	1
30	4B1330	SCREW-----	4
31	6J450	SHIM-----	4
32	4B4278	WASHER-----	1
33	6H6699	ADAPTER-----	1
34	3D5102	GROMMET-----	7
35	6H5506	CLIP----- (Long)	1
36	8M9937	BOLT-----	2
36	3K6116	WASHER-----	2
37	7S687	INDICATOR-----	1
37	1M3010	FITTING-----	1

148106

GAUGES AND INSTRUMENT PANEL (3S2028 N/S)  
Serial No. 11K6042 to 11K6440 inclusive

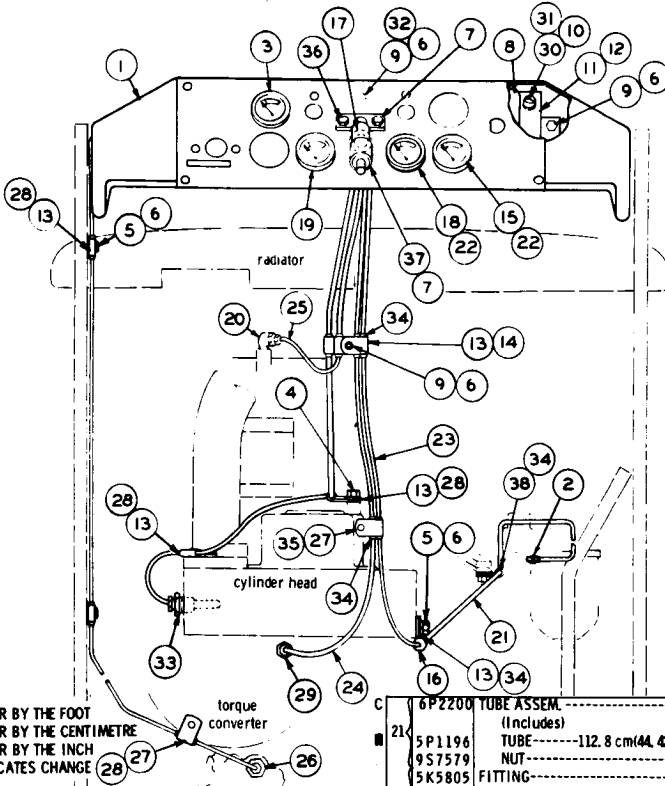

▲ ORDER BY THE FOOT  
 ■ ORDER BY THE CENTIMETRE  
 ● ORDER BY THE INCH  
 C INDICATES CHANGE

REF. NO.	PART NUMBER	DESCRIPTION	QTY
C 1	8S971	COVER	1
2	9S7580	CONNECTOR	1
3	1P5486	HEAT INDICATOR---(converter)---	1
4	S1617	BOLT	2
5	S509	BOLT	3
6	3B4506	LOCKWASHER	9
7	1P6886	ADAPTER	1
8	1P7217	INLAY	1
9	L1351	BOLT	6
10	4K3533	WASHER	4
11	1P4888	PLATE ASSEM. (Includes)	1
	9F2978	NUT	4
12	9F6445	NUT	2
13	2B2404	CLIP---(short)---	9
14	L2072	CLIP---(long)---	2
15	1P5488	GAUGE---(fuel pressure)---	1
	2D9885	FITTING	1
16		(Includes)	
	1F1344	NUT	1
● 17	9S9405	GROMMET---3 in. (7.6 cm)---	1
18	1P5487	GAUGE---(oil pressure)---	1
19	9M2745	INDICATOR---(water temp.)---	1
C 20	8H6912	FITTING	1

C	6P2200	TUBE ASSEM. (Includes)	1	
21	5P1196	TUBE---112.8 cm (44.42 in.)	1	
	9S7579	NUT	1	
	5K5805	FITTING (Includes)	2	
22	5K5804	NUT	1	
	5K5803	SLEEVE	1	
▲ 23	4S8381	TUBE---42 in. (106.6 cm)	1	
▲ 24	4S8381	TUBE---45 in. (114.3 cm)	1	
▲ 25	4S8381	TUBE---39 in. (99 cm)	1	
	5B1959	ADAPTER	1	
26	2B5721	GASKET	1	
	27	6H3068	CLIP---(short)---	2
	28	8F244	GROMMET	7
C 29	5P2948	CONNECTOR	1	
	3B6768	BUSHING	1	
	30	4B1330	SCREW	4
	31	6J450	SHIM	4
	32	4B4278	WASHER	1
	33	6H6699	ADAPTER	1
	34	3D5102	GROMMET	7
	35	6H5506	CLIP---(long)---	1
	36	8M9937	BOLT	2
	36	3K6116	WASHER	2
	37	7S687	INDICATOR	1
	1M3010	FITTING	1	
C 38	1A5350	CLIP	1	

GAUGES AND INSTRUMENT PANEL (3S2028 N/S)  
 Serial No. 11K6441 to 11K6832 inclusive

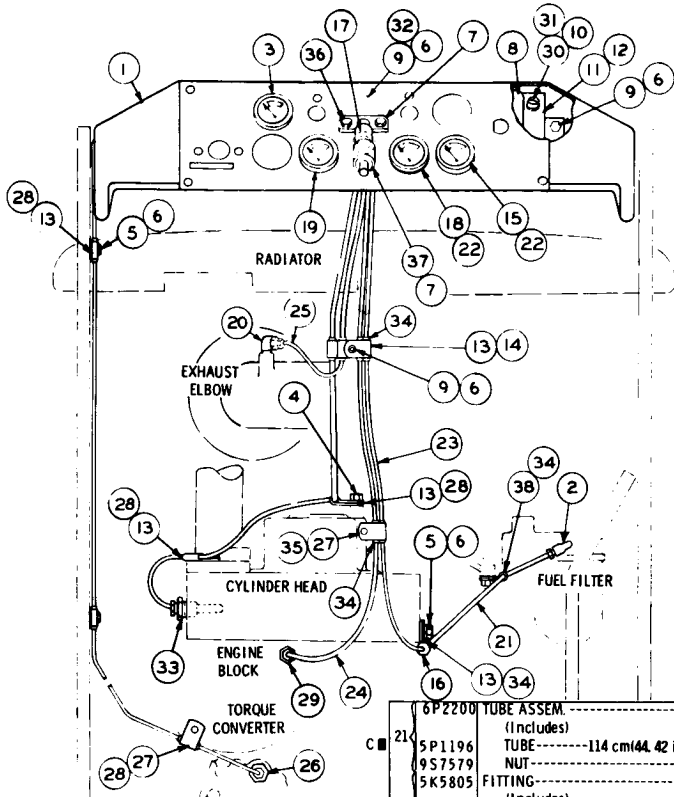

REF NO.	PART NUMBER	DESCRIPTION	QTY
1	8S971	COVER-----	1
2	9S7580	CONNECTOR-----	1
3	1P5486	HEAT INDICATOR----(converter)-----	1
4	51617	BOLT-----	2
5	5509	BOLT-----	3
6	3B4506	LOCKWASHER-----	9
7	1P6886	ADAPTER-----	1
8	1P7217	INLAY-----	1
9	L1351	BOLT-----	6
10	4K3533	WASHER-----	4
11	1P4888	PLATE ASSEM.-----	1
		(Includes)	
	9F2978	NUT-----	4
	9F6445	NUT-----	2
12	2B2404	CLIP----- (short)-----	9
13	L2072	CLIP----- (long)-----	2
14	1P5488	GAUGE----- (fuel pressure)-----	1
15	2D9885	FITTING-----	1
16		(Includes)	
	1F1344	NUT-----	1
17	9S9405	GROMMET----- 3 in. (7.6 cm)-----	1
18	1P5487	GAUGE----- (oil pressure)-----	1
19	9M2745	INDICATOR----- (water temp.)-----	1
20	8H6912	FITTING-----	1

● ORDER BY THE INCH  
C INDICATES CHANGE

	6P2200	TUBE ASSEM.-----	1
		(Includes)	
C	21	5P1196 TUBE----- 114 cm(44.42 in.)	1
		9S7579 NUT-----	1
		5K5805 FITTING-----	2
		(Includes)	
	22	5K5804 NUT-----	1
		5K5803 SLEEVE-----	1
C	A	23 5P580 TUBE----- 10.66 dm(42 in.)	1
C	A	24 5P580 TUBE----- 11.43 dm(45 in.)	1
C	A	25 5P580 TUBE----- 9.90 dm(39 in.)	1
C	26	6H6699 ADAPTER-----	1
	27	6H3068 CLIP----- (short)-----	2
	28	8F244 GROMMET-----	7
	29	5P2948 CONNECTOR-----	1
		3B6768 BUSHING-----	1
	30	4B1330 SCREW-----	4
	31	6J450 SHIM-----	4
	32	4B4278 WASHER-----	1
	33	6H6699 ADAPTER-----	1
	34	3D5102 GROMMET-----	7
	35	6H5506 CLIP----- (long)-----	1
	36	8M9937 BOLT-----	2
		3K6116 WASHER-----	2
	37	7S687 INDICATOR-----	1
		1M3010 FITTING-----	1
	38	1A5350 CLIP-----	1

▲ ORDER BY THE DECIMETRE  
■ ORDER BY THE CENTIMETRE

152567

GAUGES AND INSTRUMENT PANEL (3S2028 N/S)  
Serial No. 11K6833—Up

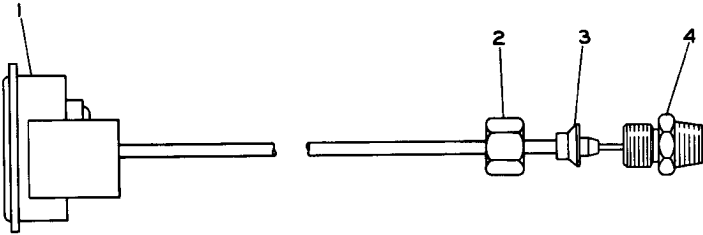

REF. NO.	PART NUMBER	DESCRIPTION	QTY
1	3S4131	GAUGE---(Water Pressure)---	1
2	1P8563	NUT-----	1
3	1P8561	SLEEVE-----	1
4	1P8560	CONNECTOR-----	1
	1P9132	ELBOW----- (90°)---	1
		(Not Shown)	

111984

9S2326 WATER PRESSURE GAUGE GROUP—Field Installation

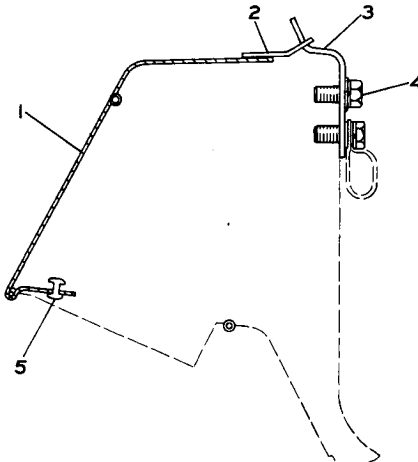

REF. NO.	PART NUMBER	DESCRIPTION	QTY
1	3S5325	DOOR ASSEM.-----	1
2	4S9205	HASP-----	1
3	8S987	STAPLE-----	1

	L1351	BOLT-----	2
4	3B4506	LOCKWASHER-----	2
	4B4278	WASHER-----	2
5	9M5733	RIVET-----	5
	8S7949	PADLOCK GROUP-----	1
		(NOT SHOWN-Consists of 1 Padlock And 2 Key)	

136140

2P5287 VANDALISM GUARD GROUP—Instrument Panel  
Part of 2P5300 Vandalism Protection Arrangement  
AN ATTACHMENT



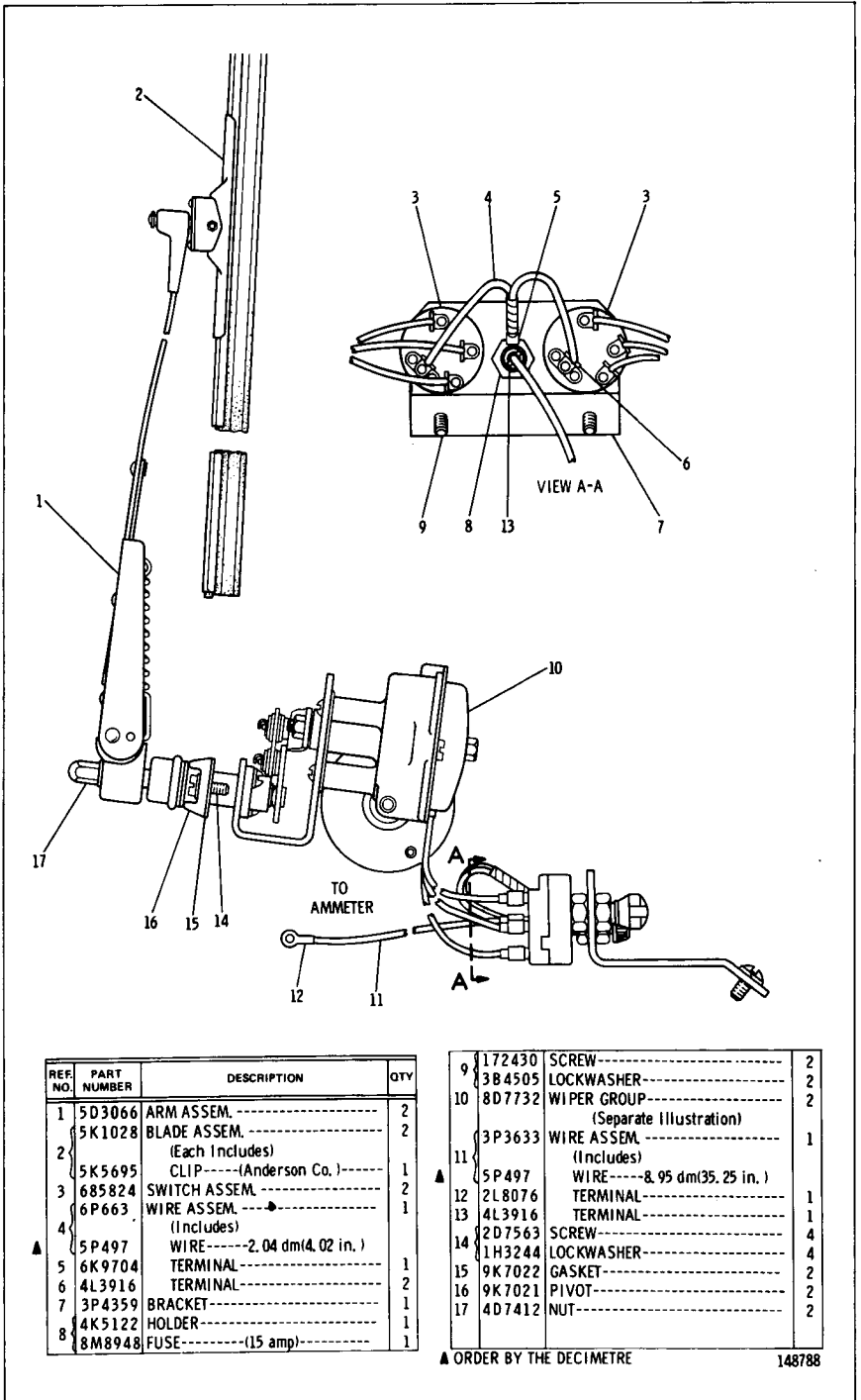

REF. NO.	PART NUMBER	DESCRIPTION	QTY
1	5D3066	ARM ASSEM. -----	2
	5K1028	BLADE ASSEM. -----	2
2		(Each Includes)	
	5K5695	CLIP----- (Anderson Co.)-----	1
3	685824	SWITCH ASSEM. -----	2
	6P663	WIRE ASSEM. -----	1
4		(Includes)	
▲	5P497	WIRE-----2.04 dm(4.02 in.)	1
5	6K9704	TERMINAL-----	1
6	4L3916	TERMINAL-----	2
7	3P4359	BRACKET-----	1
8	4K5122	HOLDER-----	1
	8M8948	FUSE----- (15 amp)-----	1

9	172430	SCREW-----	2
	3B4505	LOCKWASHER-----	2
10	8D7732	WIPER GROUP-----	2
		(Separate Illustration)	
	3P3633	WIRE ASSEM. -----	1
11		(Includes)	
▲	5P497	WIRE-----8.95 dm(35.25 in.)	1
12	2L8076	TERMINAL-----	1
13	4L3916	TERMINAL-----	1
14	2D7563	SCREW-----	4
	1H3244	LOCKWASHER-----	4
15	9K7022	GASKET-----	2
16	9K7021	PIVOT-----	2
17	4D7412	NUT-----	2

▲ ORDER BY THE DECIMETRE

148788

6P557 WINDSHIELD WIPER GROUP—24 Volt  
8D7732 Wiper parts are shown on Page 226D

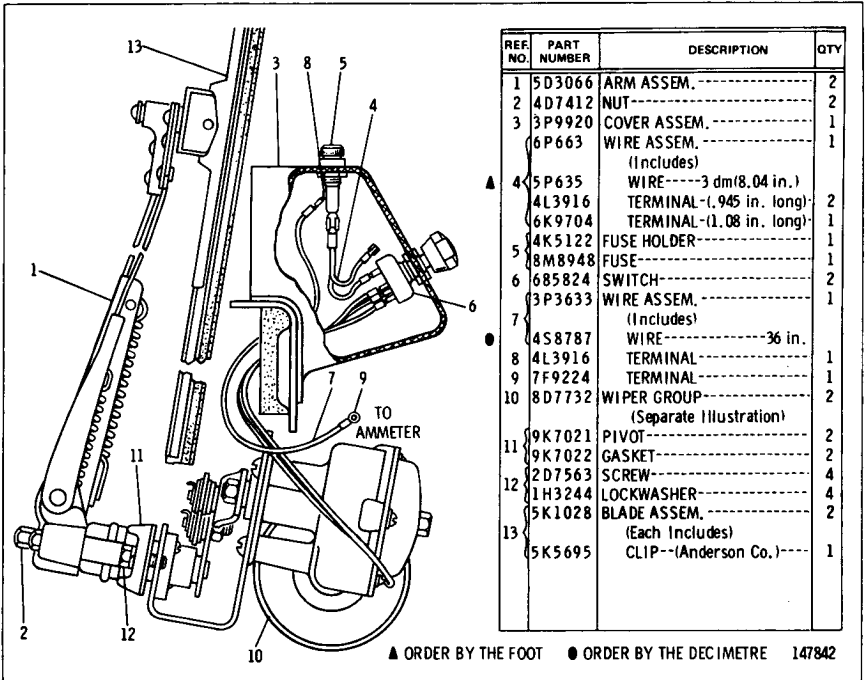

3P9921 WINDSHIELD WIPER GROUP—24 Volt  
 FOR USE WITH 3P9933 ROLL-OVER PROTECTIVE SYSTEM SHOWN ON PAGE 248D  
 8D7732 Wiper parts are shown on Page 226D

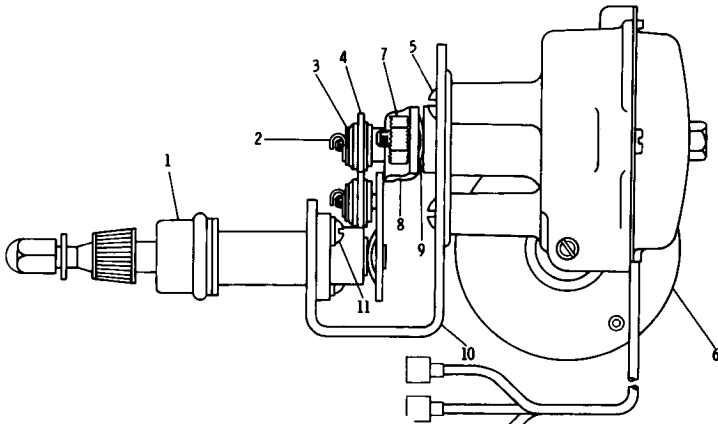

REF. NO.	PART NUMBER	DESCRIPTION	QTY
1	9D4510	SHAFT & LINK ASSEM.----- (Separate Illustration)	1
2	4D7411	CLIP-----	2
3	4D7416	SPACER-----	2
4	4D7408	LINK-----	1
5	4B1264	SCREW-----	3
	1H3338	LOCKWASHER-----	3

6	9D202	MOTOR ASSEM.-----	1
	184201	NUT-----	1
7	7F9223	LOCKWASHER-----	1
8	6K5499	ARM-----	1
9	4D7421	WASHER-----	1
10	4D7417	BRACKET-----	1
11	8F1315	SCREW ASSEM.-----	2

119801

8D7732 WIPER GROUP

Part of 6P557 and 3P9921 Windshield Wiper Groups shown on Pages 226A & 226C

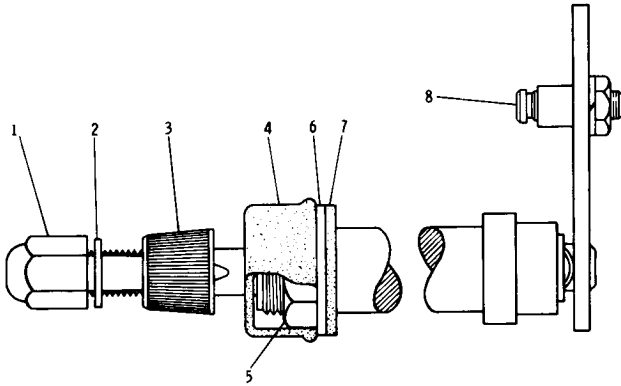

REF. NO.	PART NUMBER	DESCRIPTION	QTY
1	8D237	NUT-----	1
2	9F5644	LOCKWASHER-----	1
3	1V3658	DRIVER-----	1
4	1V3657	CAP-----	1
5	1V3656	NUT-----	1

6	4B1550	WASHER-----	1
7	9S8016	GASKET-----	1
	1V3655	STUD-----	1
8	9M1311	NUT-----	1
	1H3244	LOCKWASHER-----	1

119887

9D4510 SHAFT AND PIVOT ASSEMBLY  
Part of 8D7732 Wiper Group

2P5300 VANDALISM PROTECTION ARRANGEMENT  
 CONSISTS OF:

PAGE

1	2P7611	PROTECTION COVER GROUP.....	94
1	5D1910	PROTECTION COVER GROUP.....	150
1	1P8678	PROTECTION CAP GROUP.....	23
1	2P5287	VANDALISM GUARD GROUP.....	226
5	.....	PADLOCK	

3P7735 VANDALISM PROTECTION ARRANGEMENT  
 FOR USE WITH ENCLOSED ROPS  
 CONSISTS OF:

1	5D1910	HYDRAULIC TANK PROTECTION COVER GROUP....	150
1	1P8678	FUEL TANK CAP PROTECTION COVER GROUP.....	23
2	8M438	PADLOCK--TO HOOD DOOR AND RADIATOR FILL COVER	

VANDALISM PROTECTION ARRANGEMENTS  
 AN ATTACHMENT

TO L. H. WIPER ASSEM.

TO AMMETER

REF. NO.	PART NUMBER	DESCRIPTION	QTY
1	5D3066	ARM ASSEM.-----	2
2	5K1028	BLADE ASSEM.-----	2
3	3P4359	BRACKET-----	1
3	3P3636	WIRE ASSEM.-----	1
4	4S8787	WIRE-----4 in.	1
6	6K613	TERMINAL-----	1
5	4L3916	TERMINAL-----	1
4	4D4071	SWITCH-----	1
6	3F7747	CONNECTOR-----	3
7	4K5122	FUSE HOLDER-----	1
7	8M8948	FUSE----- (15 amp)	1
3	3P3633	WIRE ASSEM.-----	1
8	4S8787	WIRE-----36 in.	1
8	4L3916	TERMINAL-----	1
9	2L8076	TERMINAL-----	1
10	172430	SCREW-----	2
10	3B4504	LOCKWASHER-----	2
11	3P4006	WIPER ASSEM.-----	2
12	2D7563	SCREW-----	4
12	1H3244	LOCKWASHER-----	4
13	9K7021	PIVOT-----	2
13	9K7022	GASKET-----	2
14	4D7412	NUT-----	2

▲ ORDER BY THE FOOT C INDICATES CHANGE 144623

3P3634 WINDSHIELD WIPER GROUP—24 Volt  
 FOR USE WITH 3P3195 ROLL-OVER PROTECTIVE STRUCTURE SHOWN  
 ON PAGE 249. AN ATTACHMENT

CATERPILLAR 977L TRAXCAVATOR

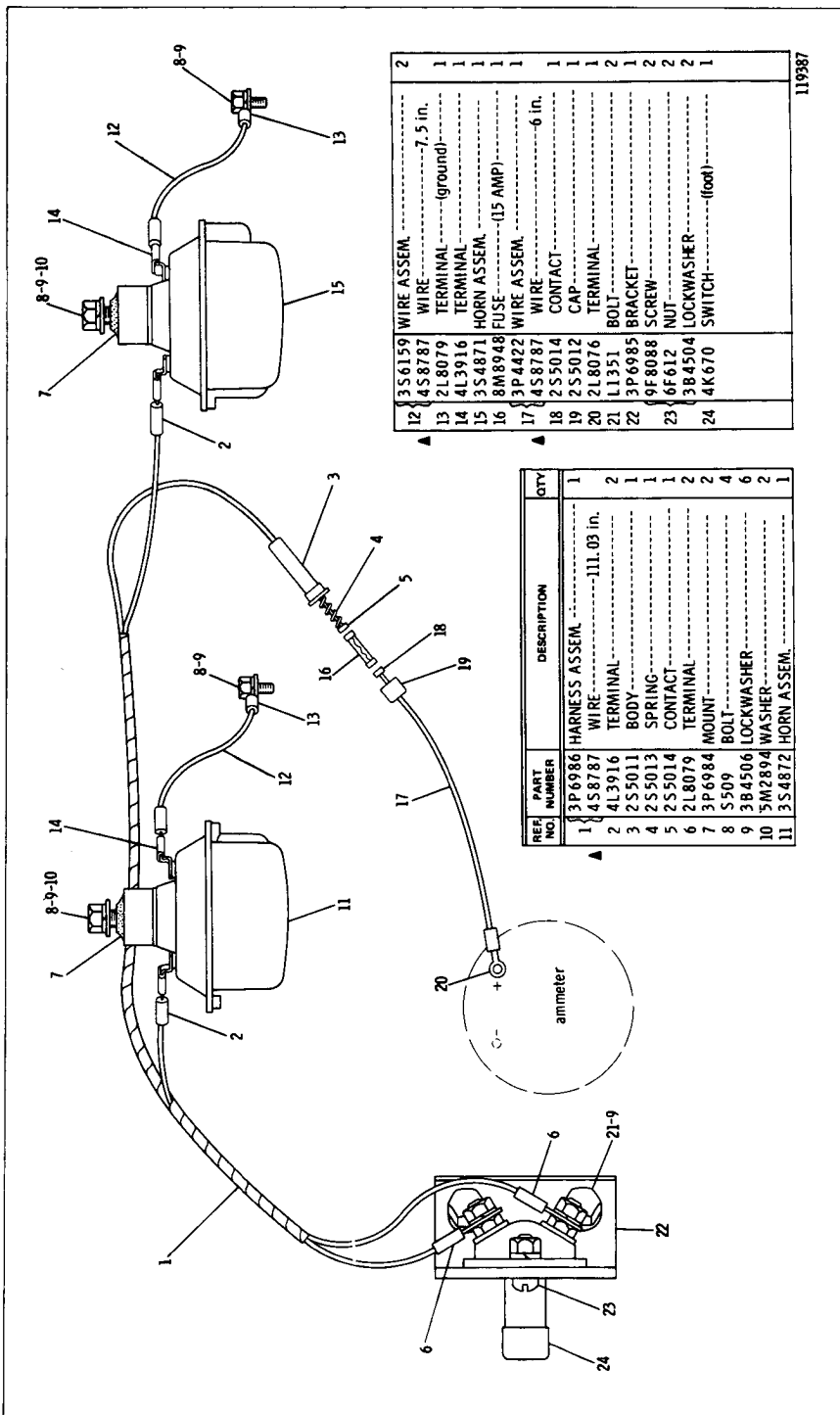

3 56159	WIRE ASSEM.	2
4 58787	WIRE .....7.5 in.	1
21 28079	TERMINAL .....(ground)	1
4 43916	TERMINAL	1
3 54871	HORN ASSEM.	1
8 8948	FUSE .....(15 AMP)	1
3 4422	WIRE ASSEM.	1
4 58787	WIRE .....6 in.	1
2 55014	CONTACT	1
2 55012	CAP	1
21 28076	TERMINAL	1
21 11351	BOLT	2
3 6985	BRACKET	2
9 8088	SCREW	2
9 6612	NUT	2
3 84504	LOCKWASHER	2
4 670	SWITCH	1

REF. NO.	PART NUMBER	DESCRIPTION	QTY
1	3 6986	HARNES ASSEM.	1
2	4 58787	WIRE .....111.03 in.	2
3	4 3916	TERMINAL	1
4	2 5011	BODY	1
5	2 5013	SPRING	1
6	2 5014	CONTACT	1
7	2 8079	TERMINAL	2
8	3 6984	MOUNT	2
9	5 509	BOLT	4
10	3 84506	LOCKWASHER	6
11	5 2894	WASHER	2
12	3 54872	HORN ASSEM.	1

119387

3P6983 ELECTRIC HORN GROUP  
 Serial No. 11K5417—Up  
 AN ATTACHMENT

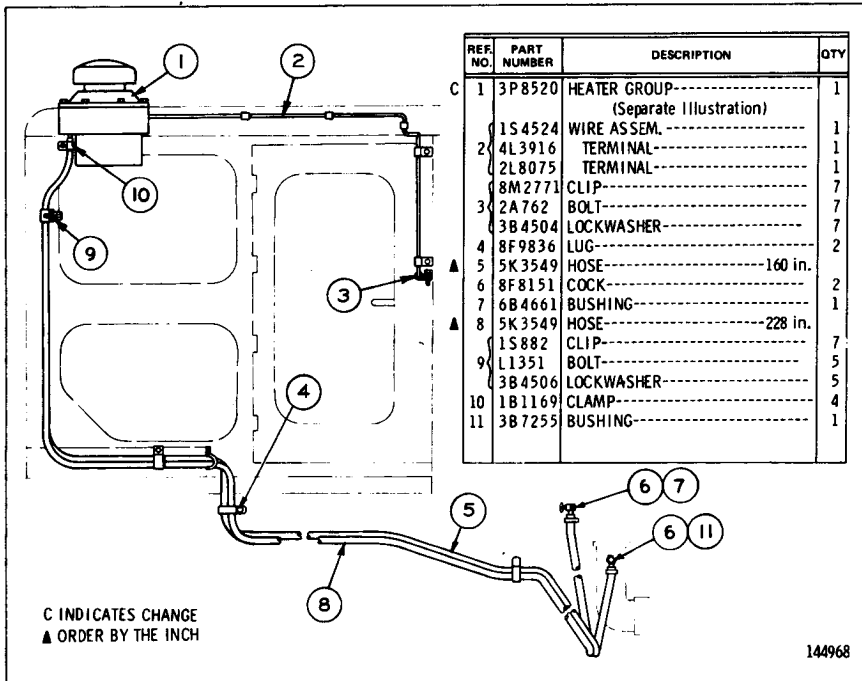

3P3678 CAB HEATER GROUP—Roof Mounted—24 Volt  
FOR USE WITH 3P3195 ROLL-OVER PROTECTIVE STRUCTURE  
SHOWN ON PAGE 249. AN ATTACHMENT

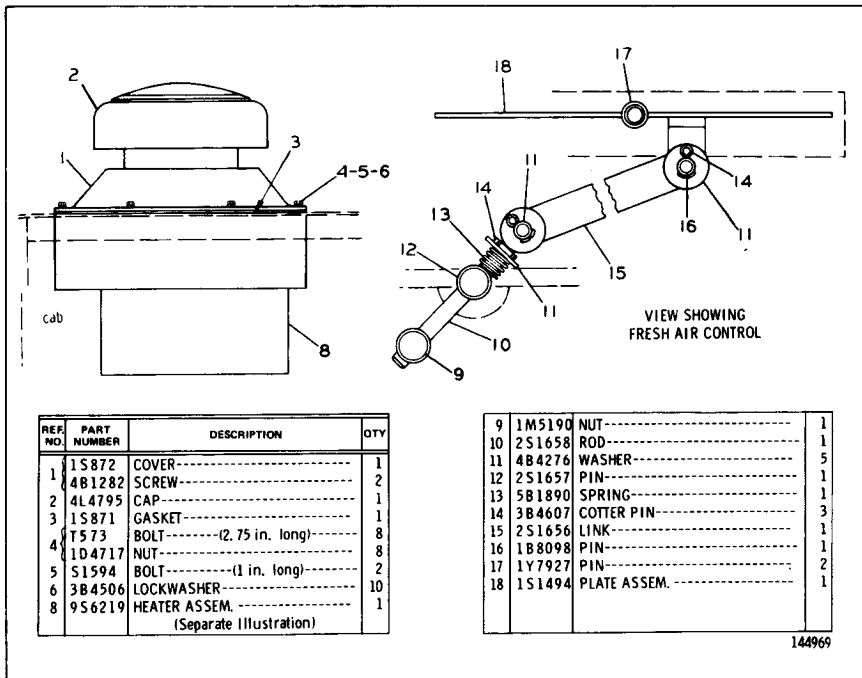

3P8520 CAB HEATER GROUP—24 Volt—Type 1  
Part of 3P3678 Heater Group  
9S6219 Heater parts are shown on Page 230A  
AN ATTACHMENT

144968

144969

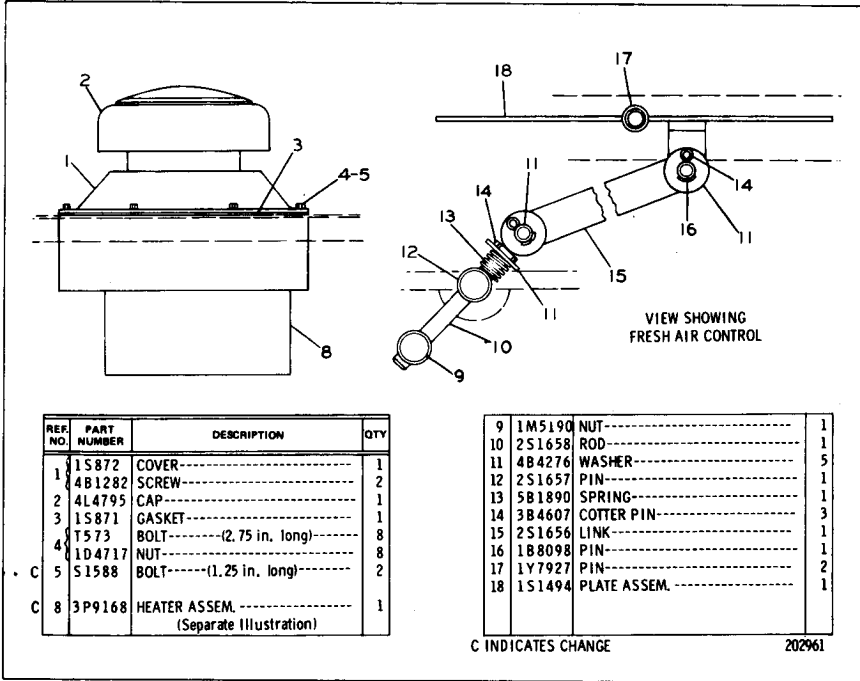

REF NO.	PART NUMBER	DESCRIPTION	QTY
1	1S872	COVER-----	1
1	4B1282	SCREW-----	2
2	4L4795	CAP-----	1
3	1S871	GASKET-----	1
4	T573	BOLT----- (2.75 in. long)-----	8
4	1D4717	NUT-----	8
C 5	S1588	BOLT----- (1.25 in. long)-----	2
C 8	3P9168	HEATER ASSEM.----- (Separate Illustration)	1

9	1M5190	NUT-----	1
10	2S1658	ROD-----	1
11	4B4276	WASHER-----	5
12	2S1657	PIN-----	1
13	5B1890	SPRING-----	1
14	3B4607	COTTER PIN-----	3
15	2S1656	LINK-----	1
16	1B8098	PIN-----	1
17	1Y7927	PIN-----	2
18	1S1494	PLATE ASSEM.-----	1

C INDICATES CHANGE

202961

3P8520 CAB HEATER GROUP—24 Volt—Type 2  
 Part of 3P3678 Heater Group shown on Page 229. 9S6219 and 3P9168  
 Heater parts are shown on Pages 230A and 231. AN ATTACHMENT

9S6219 HOT WATER HEATER ASSEMBLY—24 Volt  
 Part of 3P8520 Heater Group shown on Page 229  
 AN ATTACHMENT

REF. PART NO.	PART NUMBER	DESCRIPTION	QTY
1	3K8785	GROMMET	1
2	2S3749	CLAMP	1
3	2S3736	CASE	1
4	2S3733	CLAMP	1
5	S1594	BOLT	6
6	6H8346	NUT	6
7	3K8909	LOCKWASHER	10
8	3B9191	SCREW	2
9	2S3734	CORE	1
10	2S3737	BOLT	2
11	4L6458	NUT	2
12	1H3338	LOCKWASHER	4
13	2S3738	CLAMP	1
14	S1615	BOLT	1
15	4B2049	NUT	2
16	9F5599	LOCKWASHER	4
17	2S3745	SCREW	4
18	2S3744	NUT	3
19	9S6220	MOTOR	3
20	2S3741	HOUSING	1
21	2S3740	FAN	1
22	S1588	BOLT	1
23	2K8270	NUT	4
24	2S3746	COVER	4
25	3K9075	SCREW ASSEM.	1
26	2S3747	HOLDER	1
27	8M8948	FUSE	1
	2D2684	SWITCH (Toggle)	1
	2S3750	INSULATOR	1
	5D853	SCREW	1
	2D3748	LOCKWASHER	1

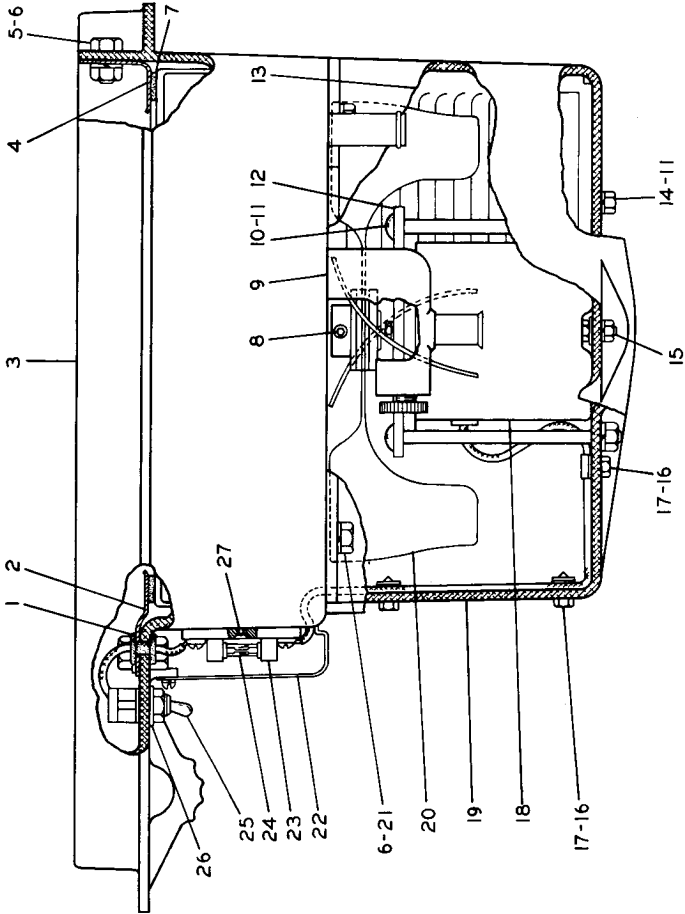



3P9168 HOT WATER HEATER ASSEMBLY—24 Volt  
 Part of 3P8520 Heater Group shown on Page 230  
 AN ATTACHMENT

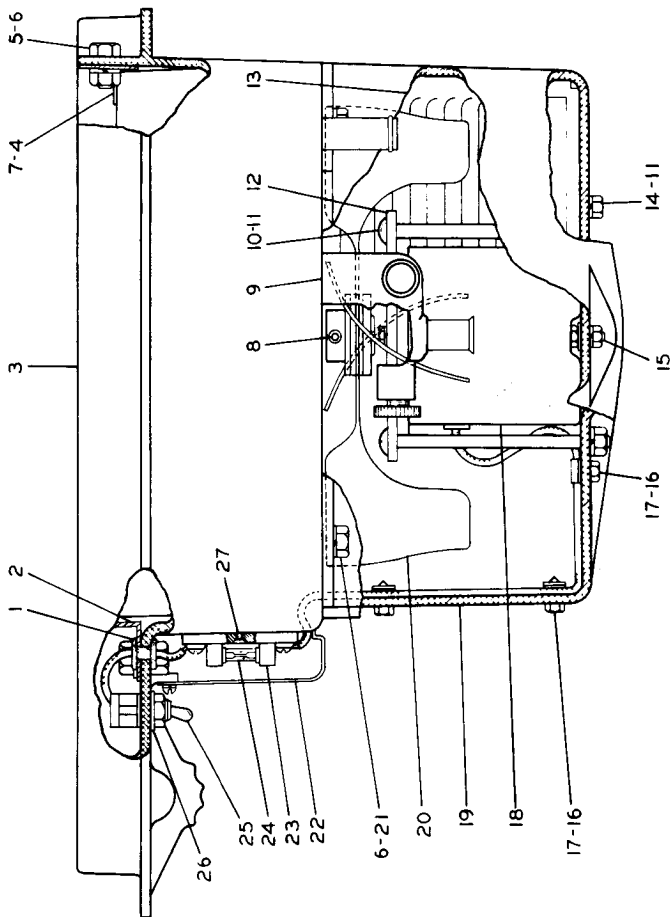

REF NO.	PART NUMBER	DESCRIPTION	QTY
1	3K8785	GROMMET	1
2	3P8338	ANGLE	1
3	2S3736	CASE	1
4	3P8337	ANGLE ASSEM.	1
5	S1594	BOLT	6
6	6H8346	NUT	6
6	3K8909	LOCKWASHER	10
7	2S3735	STRIP	2
8	3H9191	SCREW	1
9	3P8333	CORE	1
10	2S3737	BOLT	2
10	4L6458	NUT	2
11	1H3338	LOCKWASHER	4
12	2S3738	CLAMP	2
13	2S3751	GRILL	1
14	S1615	BOLT	2
15	4B2049	NUT	4
16	9F5599	LOCKWASHER	4
16	2S3745	SCREW	3
17	2S3744	NUT	3
18	9S6220	MOTOR	1
19	2S3741	HOUSING	1
20	2S3740	FAN	1
21	S1588	BOLT	4
21	2K8270	NUT	4
22	2S3746	COVER	1
22	3K9075	SCREW ASSEM.	1
23	2S3747	HOLDER	1
24	8M8948	FUSE	1
25	2D2684	SWITCH (Toggle)	1
26	2S3750	INSULATOR	1
26	5D853	SCREW	1
27	2D3748	LOCKWASHER	1

148244

▲ ORDER BY THE FOOT

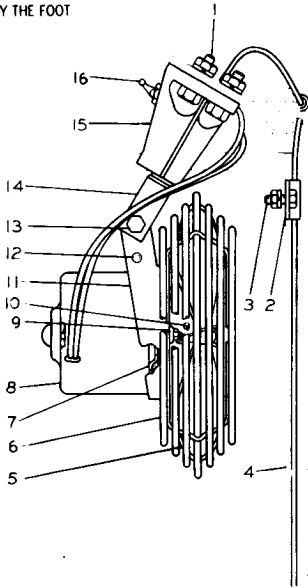

REF NO	PART NUMBER	DESCRIPTION	QTY
1	51618	BOLT-----	4
14	1D4716	NUT-----	4
	3B4505	LOCKWASHER-----	4
2	8M2771	CLIP-----	8
34	2A762	BOLT-----	8
	1B4330	NUT-----	8
4	3B4504	LOCKWASHER-----	8
	458787	WIRE-----120 in	1
4	2L8075	TERMINAL----- (No. 8 Screw)	1
	2L8076	TERMINAL----- (No. 10 Screw)	1
4	3F7747	CONNECTOR-----	1
		(Used with Windshield Wiper & Heater)	
5	5D2856	FAN GROUP-----	1
5	3D8748	FAN ASSEM.-----	1
	3D8749	GUARD-----	1
6	4D6624	WASHER-----	1
8	6D5716	MOTOR ASSEM.-----	1
9	1M1230	NUT & LOCK ASSEM.-----	2
	9F9831	WASHER-----	2
10	7L8316	SETSCREW-----	1
11	3D8745	BRACKET-----	1
12	4D128	SCREW-----	1
13	3D8761	BOLT-----	1
	3D8753	NUT-----	1
14	4B4276	WASHER-----	4
	3D8747	BRACKET-----	1
15	3D8743	BASE ASSEM.-----	1
	3D8752	NUT-----	1
16	4B4277	WASHER-----	2
	3D8754	SWITCH ASSEM.-----	1

117113

**3P3637 DEFROSTER FAN GROUP--24 Volt  
AN ATTACHMENT**

- 3P3834 ARRANGEMENT--FACTORY INSTALLATION--TYPE 1  
SERIAL No. 11K5051 to 11K6440 INCLUSIVE. FOR USE  
WITH 3P3195 ROLL-OVER PROTECTIVE STRUCTURE AND  
24 VOLT, 50 AMPERE ALTERNATOR  
CONSISTS OF: PAGE
- 1 4N6393 REFRIGERANT COMPRESSOR ARRANGEMENT.... 233
  - 1 3P3835 AIR CONDITIONER ARRANGEMENT.....232A
- 3P3834 ARRANGEMENT--FACTORY INSTALLATION--TYPE 2  
SERIAL No. 11K5051 to 11K6440 INCLUSIVE. FOR USE  
WITH 3P3195 ROLL-OVER PROTECTIVE STRUCTURE OR  
6P2925 SOUND SUPPRESSION ARRANGEMENT AND 24  
VOLT, 50 AMPERE ALTERNATOR  
CONSISTS OF:
- 1 4N6393 REFRIGERANT COMPRESSOR ARRANGEMENT.... 233
  - 1 6P2932 AIR CONDITIONER ARRANGEMENT.....232A
- 6P2656 ARRANGEMENT--FACTORY INSTALLATION. SERIAL No.  
11K6441-UP. FOR USE WITH 3P3195 ROLL-OVER  
PROTECTIVE STRUCTURE OR 6P2925 SOUND SUPPRESSION  
ARRANGEMENT AND 24 VOLT, 50 AMPERE ALTERNATOR  
CONSISTS OF:
- 1 6N206 REFRIGERANT COMPRESSOR ARRANGEMENT.... 233
  - 1 6P2932 AIR CONDITIONER ARRANGEMENT.....232A

**AIR CONDITIONER ARRANGEMENT  
AN ATTACHMENT**

CONSISTS OF:			PAGE
1	1P3322	AIR CONDITIONER GROUP.....	236
1	1P3323	CONTROL CONSOLE GROUP.....	239
1	1P3324	RETURN AIR CONSOLE GROUP.....	239
1	3P3832	MOUNTING MODIFICATIONS GROUP.....	240

3P3835 AIR CONDITIONER ARRANGEMENT—Factory Installation  
 Serial No. 11K5051 to 11K6440 inclusive  
 Part of 3P3834 Air Conditioner Arrangement listed on Page 232

CONSISTS OF:			PAGE
1	1P3322	AIR CONDITIONER GROUP.....	236
1	1P3323	CONTROL CONSOLE GROUP.....	239
1	1P3324	RETURN AIR CONSOLE GROUP.....	239
1	6P2931	MOUNTING MODIFICATIONS GROUP.....	242D

6P2932 AIR CONDITIONER ARRANGEMENT—Factory Installation  
 Part of 3P3834 and 6P2656 Air Conditioner Arrangements listed  
 on Page 232

CONSISTS OF:		PAGE
1	1P3322 AIR CONDITIONER GROUP.....	236
1	1P3323 CONTROL CONSOLE GROUP.....	239
1	1P3324 RETURN CONSOLE GROUP.....	239
1	2P3153 AIR CONDITIONER MOUNTING MODIFICATIONS GROUP.....	243
1	..... FORM GMG00967	

**2P3154 AIR CONDITIONER ARRANGEMENT—Field Installation  
FOR USE WITH REFRIGERANT COMPRESSOR, CAB AND 24 VOLT, 50  
AMPERE ALTERNATOR. Note: 2P8029 Cab Sealing Group is available**

		PAGE
CONSISTS OF:		
1	4N6016 REFRIGERANT COMPRESSOR GROUP.....	234
1	7S1251 FUEL PRIMING PUMP GROUP.....	25
1	4N6013 VEE BELT	
1	4N6381 PULLEY ASSEMBLY--COMPRESSOR DRIVE	
CONSISTING OF:		
6	4S6137 STUD	

**4N6393 REFRIGERANT COMPRESSOR ARRANGEMENT—Factory Installation Serial No. 11K5051 to 11K6440 inclusive. FOR USE WITH 24 VOLT, 50 AMPERE ALTERNATOR. Also part of 3P3834 Air Conditioner Arrangement listed on Page 232. AN ATTACHMENT**

		PAGE
CONSISTS OF:		
1	4N6016 REFRIGERANT COMPRESSOR GROUP.....	234
1	6N1134 FUMES DISPOSAL GROUP.....	235
1	4N6013 VEE BELT	
1	4N6381 COMPRESSOR DRIVE PULLEY ASSEMBLY	
CONSISTING OF:		
6	4S6137 STUD	

**6N206 REFRIGERANT COMPRESSOR ARRANGEMENT—Factory Installation Serial No. 11K6441—Up. FOR USE WITH 24 VOLT, 50 AMPERE ALTERNATOR AND SLEEVE METERING FUEL SYSTEM. Also part of 6P2656 Air Conditioner Arrangement listed on Page 232. AN ATTACHMENT**

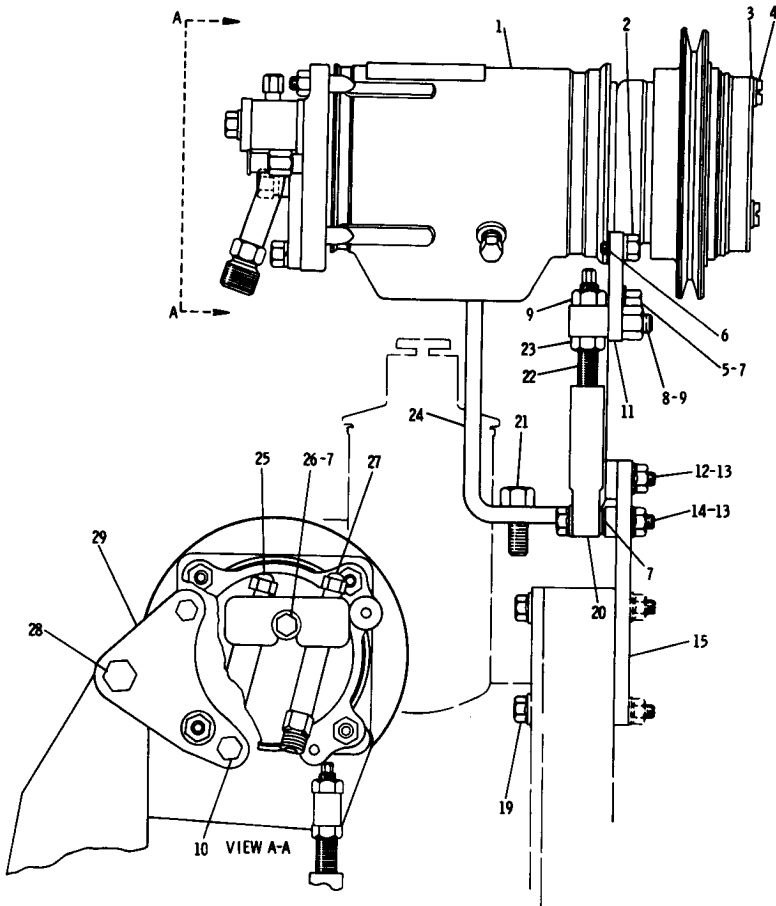

REF. NO.	PART NUMBER	DESCRIPTION	QTY
1	1P2780	COMPRESSOR GROUP----- (Separate Illustration)	1
2	4B9883	BOLT-----	2
	9M1974	WASHER-----	2
3	2P7424	COVER-----	1
4	2P7864	SCREW-----	3
5	2P3203	BOLT-----	1
6	6B6122	WASHER-----	1
7	4B4278	WASHER-----	4
8	1P2237	SWIVEL-----	1
9	1D4719	NUT-----	2
10	2P3201	BOLT-----	2
11	4N6010	PLATE-----	1
12	2P3204	BOLT-----	2
13	2P3261	NUT-----	3
14	2P3206	BOLT-----	1
15	4N6297	SUPPORT ASSEM.-----	1

19	2P3209	BOLT-----	3
20	1P2238	END-----	1
21	S1595	BOLT-----	2
22	1P2236	ROD ASSEM.-----	1
23	1D5117	NUT-----	1
24	2P6539	SUPPORT ASSEM.-----	1
	1F748	NUT-----	1
25	9S7968	FITTING ASSEM.-----	1
26	S1748	BOLT-----	1
27	9S7967	FITTING ASSEM.-----	1
	7B3235	BOLT-----	1
28	4B4280	WASHER----- (.095 in. thick)	1
	8S8320	SPACER----- (.69 in. thick)	1
29	4N6011	PLATE-----	1

119385

4N6016 REFRIGERANT COMPRESSOR GROUP—Type 1  
 Part of 4N6393 and 6N206 Refrigerant Compressor Arrangements listed on Page 233. 1P2780 Compressor parts are shown on Page 234B  
 AN ATTACHMENT

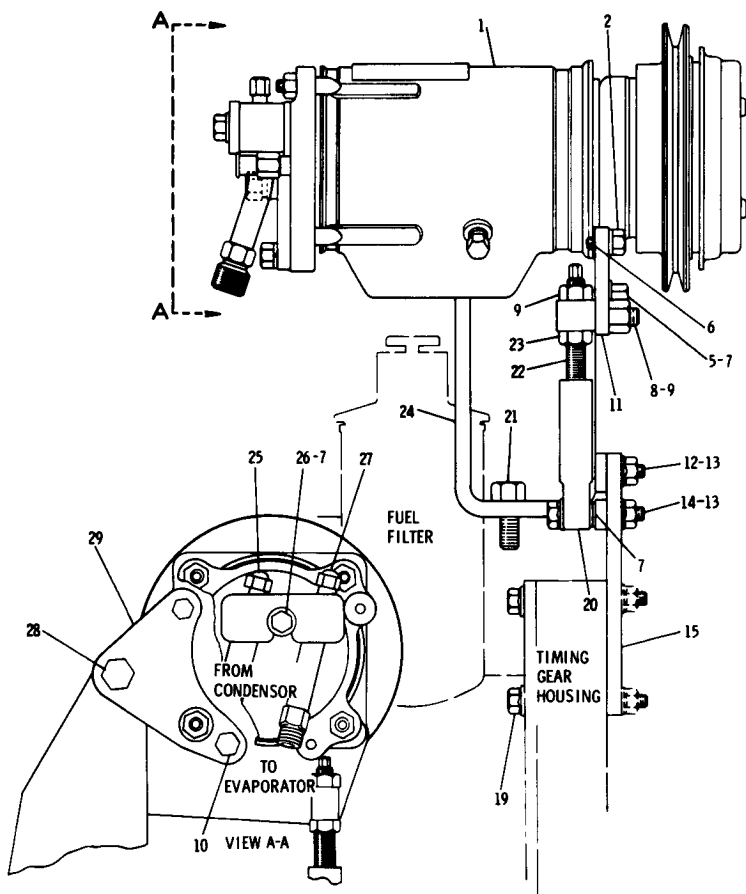

REF. NO.	PART NUMBER	DESCRIPTION	QTY
1	1P2780	COMPRESSOR GROUP----- (Separate Illustration)	1
2	4B9883	BOLT-----	2
	9M1974	WASHER-----	2
5	2P3203	BOLT-----	1
6	6B6122	WASHER-----	1
7	4B4278	WASHER-----	4
8	1P2237	SWIVEL-----	1
9	1D4719	NUT-----	2
10	2P3201	BOLT-----	2
11	4N6010	PLATE-----	1
12	2P3204	BOLT-----	2
13	2P3261	NUT-----	3
14	2P3206	BOLT-----	1
15	4N6297	SUPPORT ASSEM.-----	1

19	2P3209	BOLT-----	3
20	1P2238	END-----	1
21	S1595	BOLT-----	2
22	1P2236	ROD ASSEM.-----	1
23	1D5117	NUT-----	1
24	2P6539	SUPPORT ASSEM.-----	1
	1F748	NUT-----	1
25	9S7968	FITTING ASSEM.-----	1
26	S1748	BOLT-----	1
27	9S7967	FITTING ASSEM.-----	1
28	7B3235	BOLT-----	1
	4B4280	WASHER----- (.095 in. thick)	1
29	8S8320	SPACER----- (.69 in. thick)	1
	4N6011	PLATE-----	1

153189

4N6016 REFRIGERANT COMPRESSOR GROUP—Type 2  
 Part of 4N6393 and 6N206 Refrigerant Compressor Arrangements listed on  
 Page 233. 1P2780 Compressor parts are shown on Page 234B  
 AN ATTACHMENT

REF. NO.	PART NUMBER	DESCRIPTION	QTY
1	1P6416	COMPRESSOR GROUP-----	1
C▲	2	4N9269 COIL KIT----- (Consists of Coil Assem. & Gasket)	1
C▲	3	4N5417 PULLEY KIT----- (Consists of Pulley Assem., Shield Assem., Gasket & Seal)	1
C▲	4	4N5416 BEARING KIT----- (Consists of Bearing, Shield Assem. Seal & Gasket)	1

C INDICATES CHANGE

5	1P6361	DRIVE ASSEM.-----	1
6	1P6355	VALVE ASSEM.-----	1
C▲	7	4N5418 SEAL KIT----- (Consists of Shield Assem., Seal & Gasket)	1
▲	8	1P6357 SEAL KIT-----	1

▲ REPAIR KITS ARE AVAILABLE 150160

1P2780 REFRIGERANT COMPRESSOR GROUP—Type 1  
Part of 4N6016 Refrigerant Compressor Group shown on Pages 234 and 234A

REF. NO.	PART NUMBER	DESCRIPTION	QTY
▲	1	1P6416 COMPRESSOR GROUP-----	1
▲	2	4N9269 COIL KIT----- (Consists of Coil Assem. & Gasket)	1
▲	3	4N5417 PULLEY KIT----- (Consists of Pulley Assem., Shield Assem., Gasket & Seal)	1
▲	4	4N5416 BEARING KIT----- (Consists of Bearing, Shield Assem. Seal & Gasket)	1

C INDICATES CHANGE

5	1P6361	DRIVE ASSEM.-----	1
6	1P6355	VALVE ASSEM.-----	1
▲	7	4N5418 SEAL KIT----- (Consists of Shield Assem., Seal & Gasket)	1
▲	8	1P6357 SEAL KIT-----	1
C▲	9	6N1116 DUST COVER KIT----- (Consists of Cover & Screws)	1

▲ REPAIR KITS ARE AVAILABLE 204522

1P2780 REFRIGERANT COMPRESSOR GROUP—Type 2  
Part of 4N6016 Refrigerant Compressor Group shown on Pages 234 and 234A



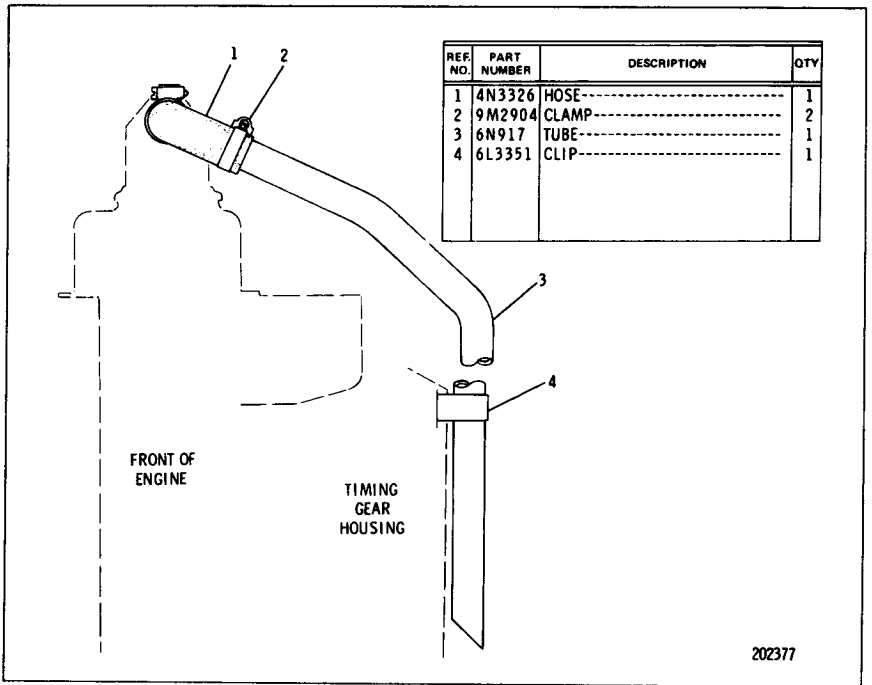

6N1134 FUMES DISPOSAL GROUP

Serial No. 11K6441—Up

Part of 6N206 Refrigerant Compressor Arrangement listed on Page 233

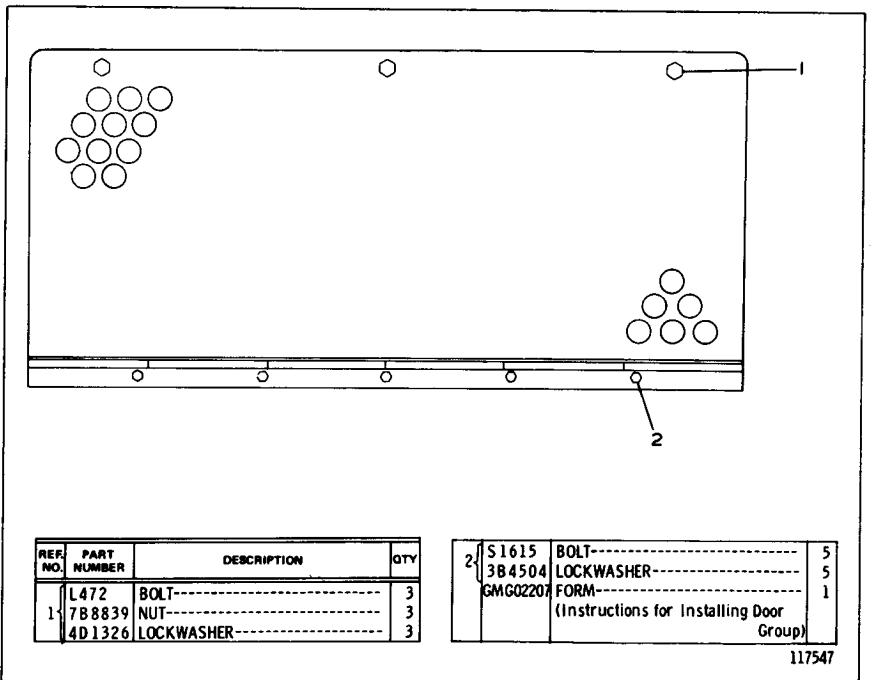

3P2103 CONDENSER SERVICE DOOR—Field Installation  
 FOR USE WITH 1P3322 AIR CONDITIONER GROUP SHOWN ON  
 PAGES 236, 237 AND 238

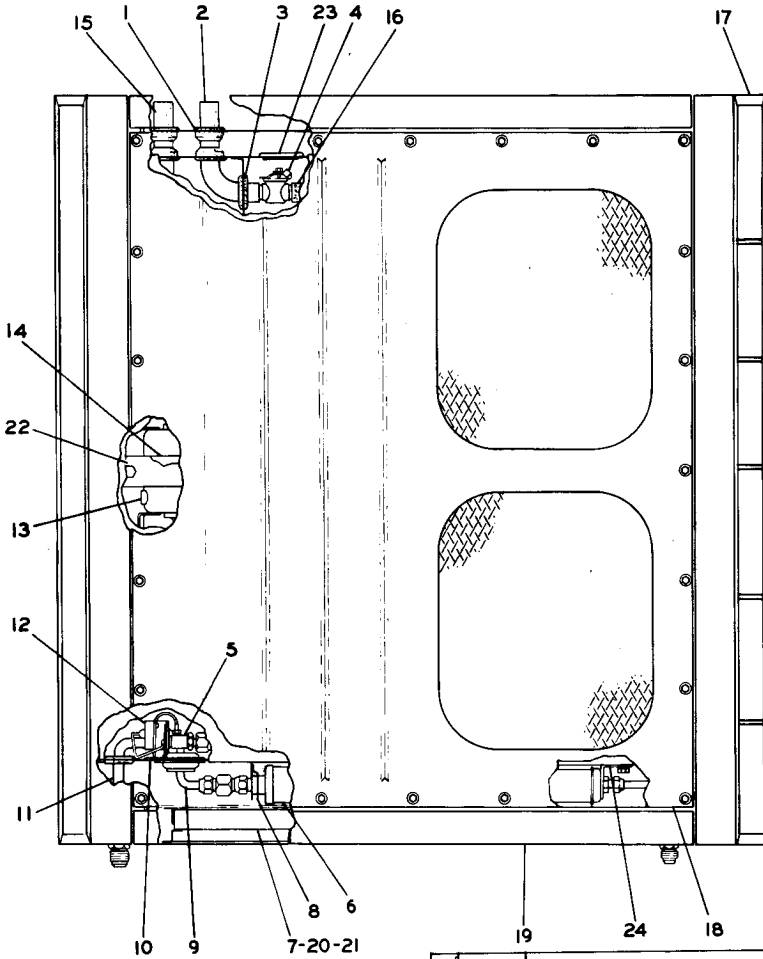

REF. NO.	PART NUMBER	DESCRIPTION	QTY
1	2P4555	GROMMET-----	4
2	1P6546	HOSE-----	1
3	1P6547	GROMMET-----	2
4	1P6544	VALVE----- (Heater)	1
5	1P6526	VALVE----- (Expansion)	1
6	1P6541	RECEIVER-----	1
7	6K9606	FILTER-----	2
8	2P4560	BRACKET-----	1
9	2P4559	TUBE ASSEM.-----	1
10	1P6525	CLAMP-----	1
11	1P6521	TUBE----- (Suction)	1
	1P6522	GROMMET-----	1

12	1P6523	CLAMP-----	1
	1P6524	SCREW-----	1
C 13	3P8379	MOTOR ASSEM.-----	1
	2P5145	BRUSH-----	2
14	1P6536	PAD-----	2
15	2P5156	HOSE-----	1
▲ 16	5K3549	HOSE----- 3"	1
17	2P4349	COVER ASSEM.-----	1
18	2P4551	COVER ASSEM.-----	1
19	2P4554	DOOR ASSEM.-----	2
20	2P4347	SEAL----- (Filter Bottom)	2
	2P4345	SEAL----- (Filter Top)	2
21	2P4346	SEAL----- (Filter Side)	4
	2P4557	STRAP-----	1
C 23	2P4344	PLUG-----	2
	2P4561	BRACKET-----	1

C INDICATES CHANGE  
▲ ORDER BY THE INCH

119289

1P3322 AIR CONDITIONER GROUP—Part 1 of 3  
Part of 3P3835 & 2P3154 Air Conditioner Arrangements  
listed on Pages 232 & 233

1P3322 AIR CONDITIONER GROUP—Part 2 of 3  
 Part of 3P3835 & 2P3154 Air Conditioner Arrangements  
 listed on Pages 232 & 233

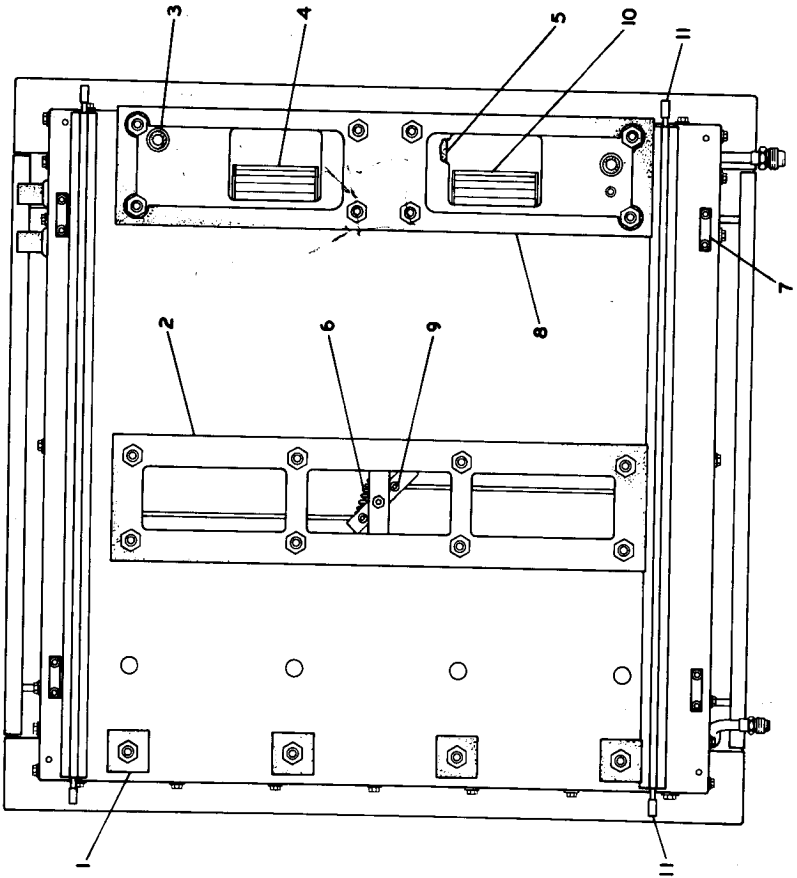

REF NO	PART NUMBER	DESCRIPTION	QTY
1	1P6500	SEAL	4
2	1P6534	SEAL	1
3	1P6528	GROMMET	2
4	1P6550	WHEEL	1
5	1P6553	SEAL	2
6	1P6540	SPRING	1
7	1P6532	PLUG	4
8	1P6533	SEAL	1
9	1P6539	RETAINER	4
C 10	3P2866	WHEEL	1
▲ C 11	5P2758	TUBE	3.0mm (in.)

▲ ORDER BY THE DECIMETRE  
 C INDICATES CHANGE

202929

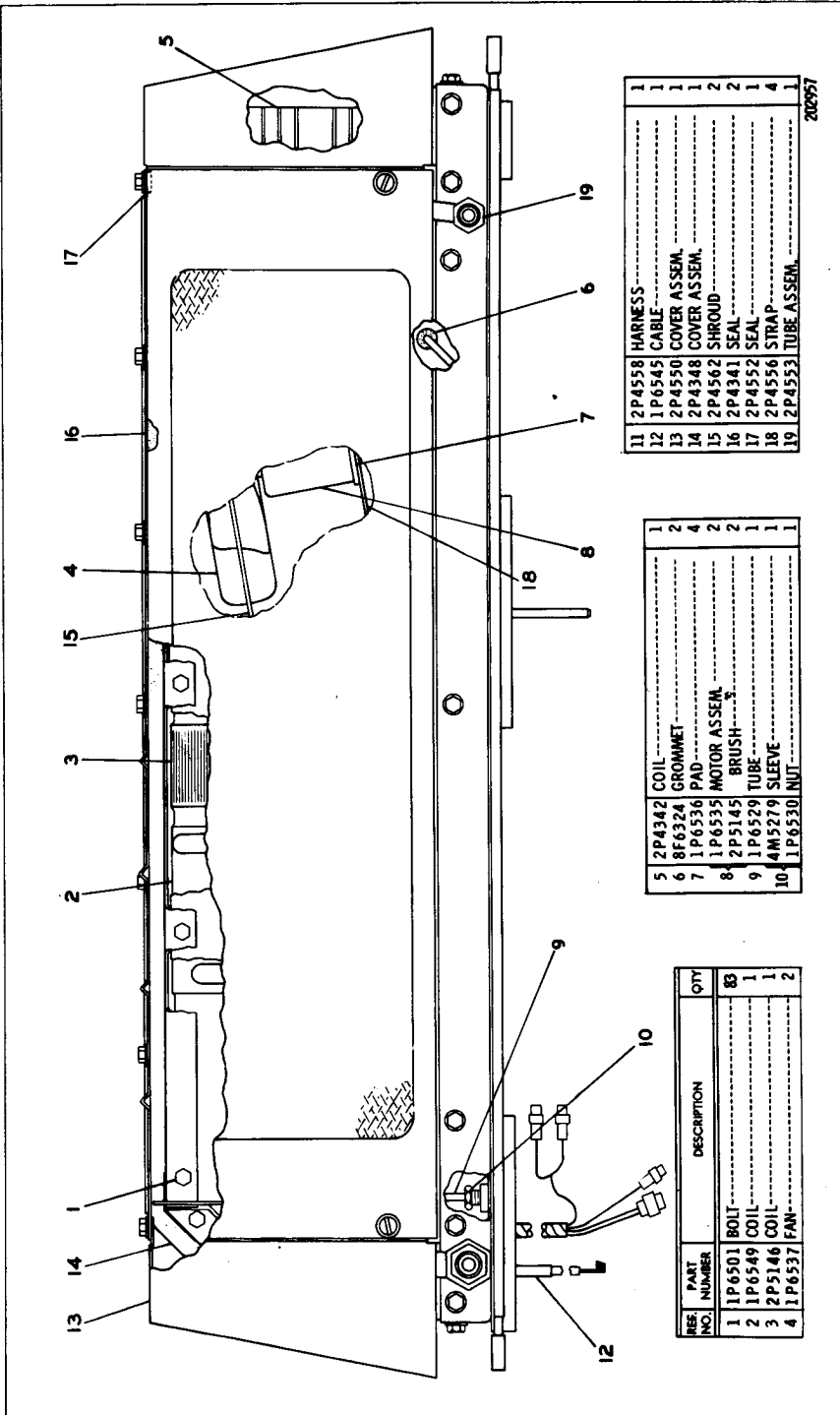

REF. NO.	PART NUMBER	DESCRIPTION	QTY
1	1P6501	BOLT	83
2	1P6549	COIL	1
3	2P5146	COIL	1
4	1P6537	FAN	2

5	2P4342	COIL	2
6	8F6324	GROMMET	2
7	1P6536	PAD	4
8	1P6535	MOTOR ASSEM.	2
9	2P5145	BRUSH	2
9	1P6529	TUBE	1
10	4M5279	SLEEVE	1
10	1P6530	NUT	1

11	2P4558	HARNES	1
12	1P6545	CABLE	1
13	2P4550	COVER ASSEM.	1
14	2P4348	COVER ASSEM.	2
15	2P4562	SHROUD	2
16	2P4341	SEAL	2
17	2P4552	SEAL	1
18	2P4556	STRAP	4
19	2P4553	TUBE ASSEM.	1

20997

1P3322 AIR CONDITIONER GROUP—Part 3 of 3  
 Part of 3P3835 & 2P3154 Air Conditioner Arrangements  
 listed on Pages 232 & 233

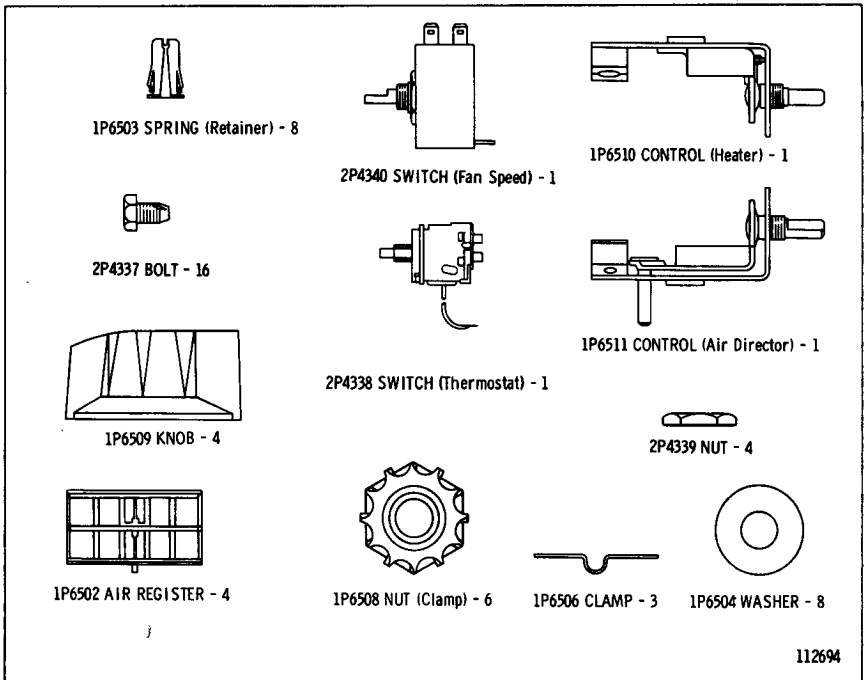

1P3323 CONTROL CONSOLE GROUP

Part of 3P3835, 6P2932 and 2P3154 Air Conditioner Arrangements listed on Pages 232A and 232B

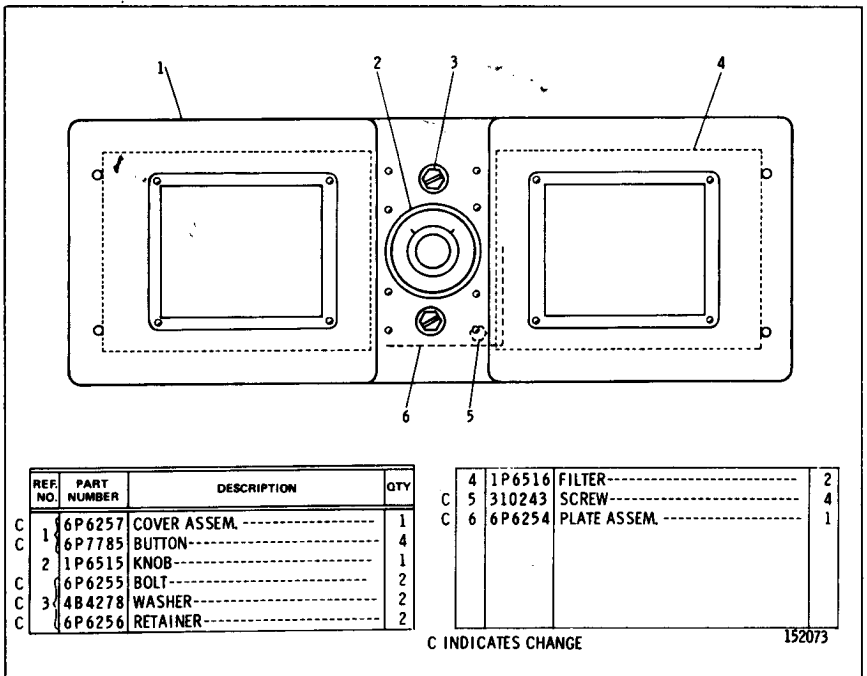

1P3324 RETURN AIR CONSOLE GROUP

Part of 3P3835, 6P2932 and 2P3154 Air Conditioner Arrangements listed on Pages 232A and 232B

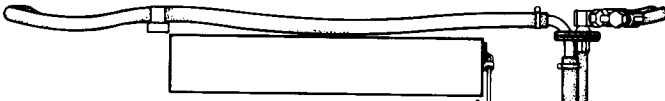

REF. NO.	PART NUMBER	DESCRIPTION	QTY
1	6D1641	CLIP-----	7
	4B4278	WASHER-----	7
	S509	BOLT-----	3
2	3B4506	LOCKWASHER-----	3
	4K2542	BOSS-----	3
	1S6160	FLANGE-----	1
3	9H8217	GASKET-----	1
4	3S2093	TIE-----	10
5	5P416	HOSE-----	
	5P487	COUPLING-----	1
6	5P488	COUPLING-----	1
7	5P415	HOSE-----	
	5P481	COUPLING-----	1
8	5P482	COUPLING-----	1
9	5K3549	HOSE-----	
10	8F8151	COCK-----	1

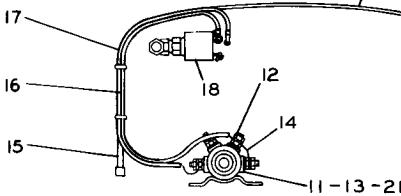

11	3P4358	SWITCH----- (Solenoid)	1
	4B2047	NUT-----	2
	3B4502	LOCKWASHER-----	2
12	4F2294	NUT-----	2
	3L6789	LOCKWASHER-----	2
	2A762	BOLT-----	2
	1B4330	NUT-----	2
13	3B4504	LOCKWASHER-----	2
	4B4276	WASHER-----	2
	5D123	WIRE ASSEM.-----	1
14	2L8079	TERMINAL-----	1
	7F9224	TERMINAL-----	1
	2P5121	WIRE ASSEM.-----	1
15	2L8076	TERMINAL-----	1
	2L8079	TERMINAL-----	1
16	8D1912	WIRE ASSEM.-----	1
	7F9224	TERMINAL-----	2
	3P4377	WIRE ASSEM.-----	1
17	4S8785	WIRE----- -13 in.	
	2L8066	TERMINAL-----	1
	2L8068	TERMINAL-----	1
	2N7744	SWITCH-----	1
18	1F9369	TEE-----	1
	3P4378	WIRE ASSEM.-----	1
	2S5011	BODY-----	1
	2S8708	CONTACT-----	1
19	2S5013	SPRING-----	1
	2L8068	TERMINAL-----	1
20	4S8785	WIRE----- -72 in.	
	6M6782	CLIP-----	6
	1S1476	CLIP-----	2
21	1P7109	BRACKET-----	1

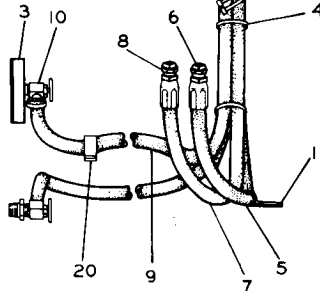

▲ ORDER BY THE FOOT  
● ORDER BY THE INCH-ORDER  
LENGTH AS REQUIRED

117116

3P3832 MOUNTING MODIFICATIONS GROUP—Part 1 of 3—Type 1  
Serial No. 11K5051 to 11K6440 inclusive. Part of 3P3835 Air  
Conditioner Arrangement listed on Page 232A. AN ATTACHMENT

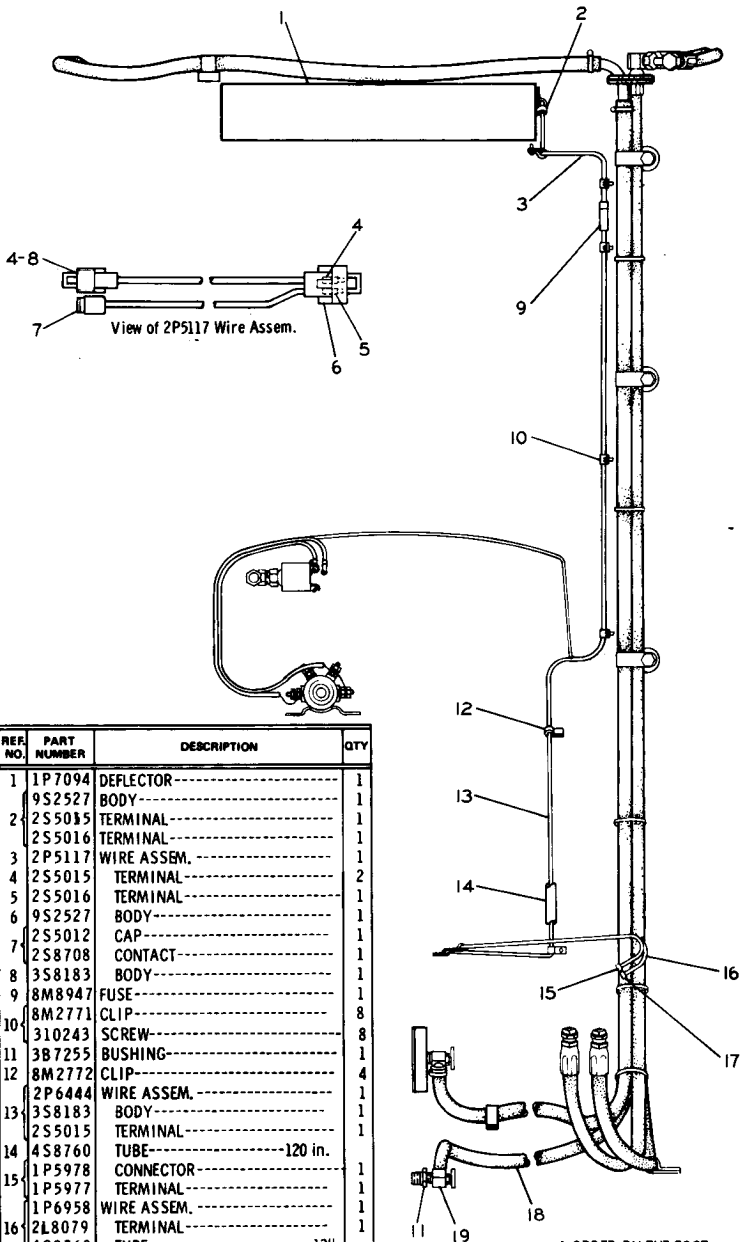

REF. NO.	PART NUMBER	DESCRIPTION	QTY
1	1P7094	DEFLECTOR-----	1
	9S2527	BODY-----	1
2	2S5015	TERMINAL-----	1
	2S5016	TERMINAL-----	1
3	2P5117	WIRE ASSEM.-----	1
4	2S5015	TERMINAL-----	2
5	2S5016	TERMINAL-----	1
6	9S2527	BODY-----	1
	2S5012	CAP-----	1
7	2S8708	CONTACT-----	1
8	3S8183	BODY-----	1
9	8M8947	FUSE-----	1
	8M2771	CLIP-----	8
10	310243	SCREW-----	8
11	3B7255	BUSHING-----	1
12	8M2772	CLIP-----	4
	2P6444	WIRE ASSEM.-----	1
13	3S8183	BODY-----	1
	2S5015	TERMINAL-----	1
▲ 14	4S8760	TUBE-----120 in.	1
	1P5978	CONNECTOR-----	1
15	1P5977	TERMINAL-----	1
	1P6958	WIRE ASSEM.-----	1
16	2L8079	TERMINAL-----	1
▲ 16	4S8760	TUBE-----13"	1
	1P5977	TERMINAL-----	1
17	1P5978	CONNECTOR-----	1
● 18	5K3549	HOSE-----	1
19	8F8151	COCK-----	1

▲ ORDER BY THE FOOT  
 ● ORDER BY THE INCH-ORDER  
 LENGTH AS REQUIRED

117117

3P3832 MOUNTING MODIFICATIONS GROUP—Part 2 of 3—Type 1  
 Serial No. 11K5051 to 11K6440 inclusive. Part of 3P3835 Air  
 Conditioner Arrangement listed on Page 232A. AN ATTACHMENT

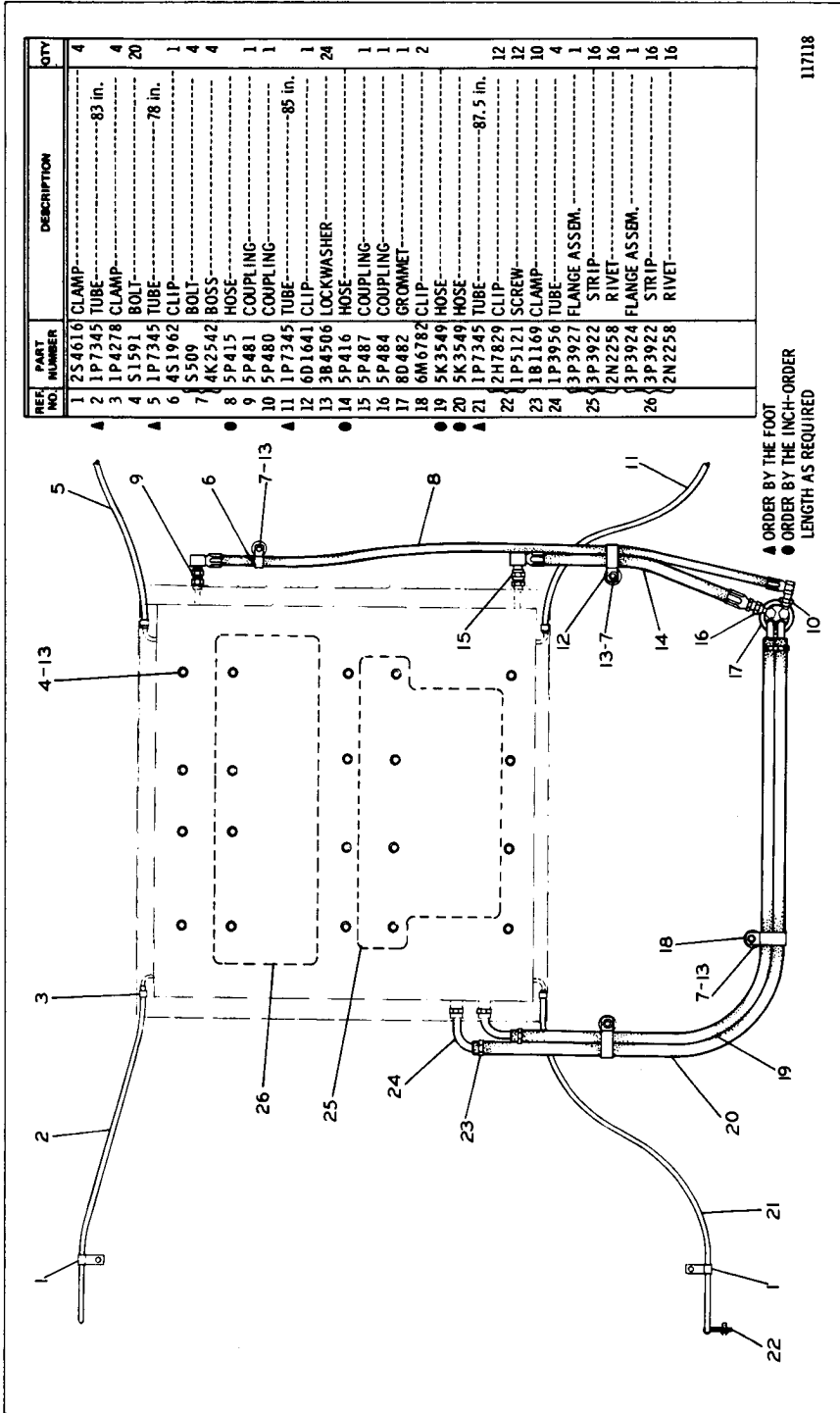

117118

▲ ORDER BY THE FOOT  
 ● ORDER BY THE INCH-ORDER  
 \_\_\_\_\_ LENGTH AS REQUIRED

3P3832 MOUNTING MODIFICATIONS GROUP—Part 3 of 3—Type 1  
 Serial No. 11K5051 to 11K6440 inclusive  
 Part of 3P3835 Air Conditioner Arrangement listed on Page 232A. AN ATTACHMENT



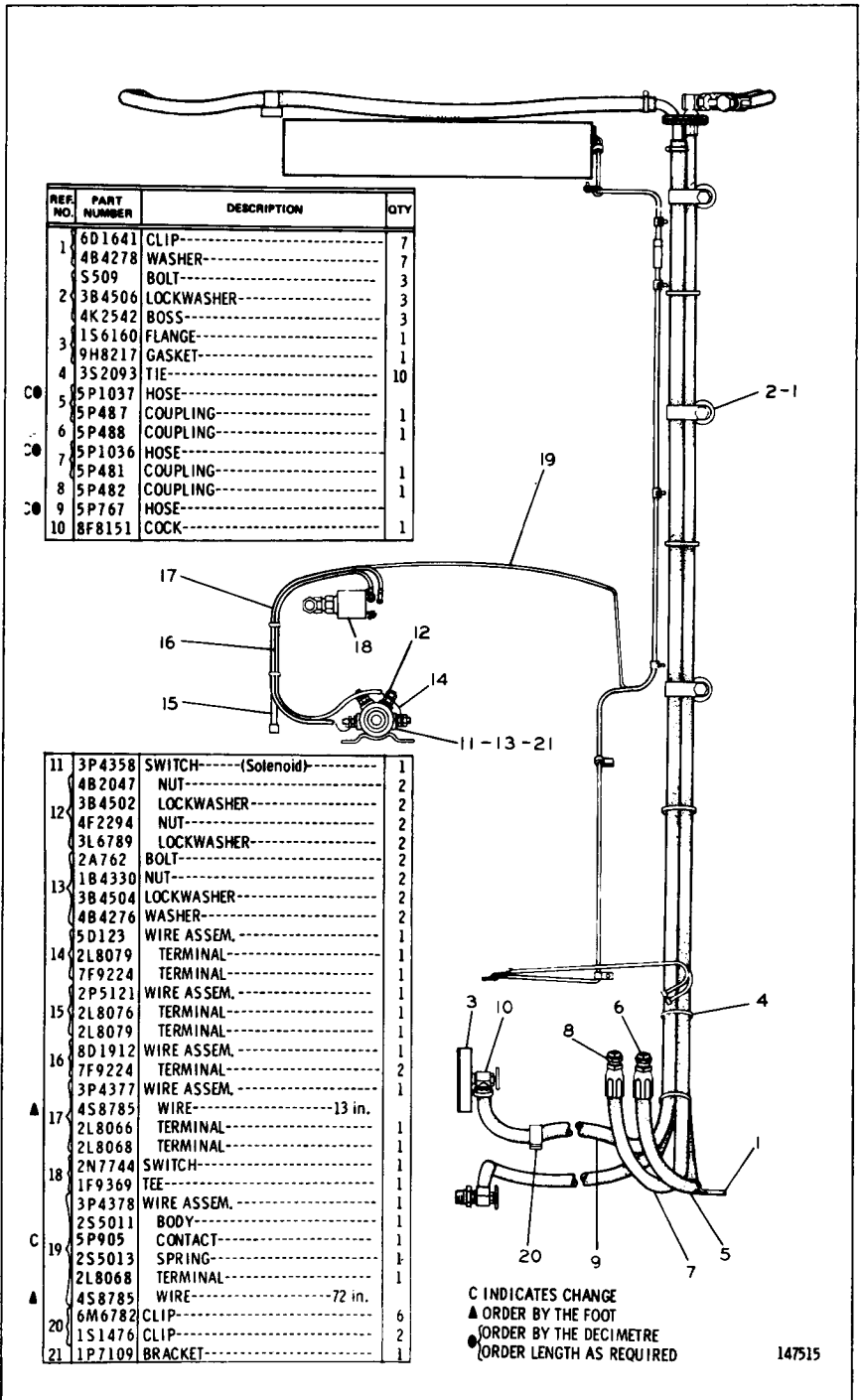

3P3832 MOUNTING MODIFICATIONS GROUP—Part 1 of 3—Type 2  
 Serial No. 11K5051 to 11K6440 inclusive. Part of 3P3835 Air  
 Conditioner Arrangement listed on Page 232A. AN ATTACHMENT

C INDICATES CHANGE  
 ▲ ORDER BY THE FOOT  
 ● ORDER BY THE DECIMETRE  
 ○ ORDER LENGTH AS REQUIRED

147515

CATERPILLAR 977L TRAXCAVATOR

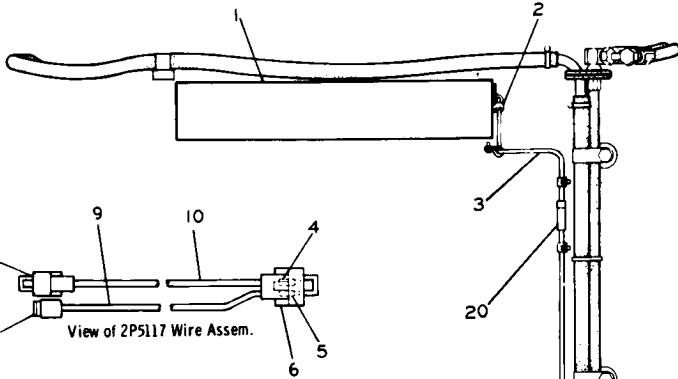

REF. NO.	PART NUMBER	DESCRIPTION	QTY
1	1P7094	DEFLECTOR	1
	9S2527	BODY	1
2	2S5015	TERMINAL	1
	2S5016	TERMINAL	1

	3	2P5117	WIRE ASSEM.	1
			(Includes)	
	4	2S5015	TERMINAL	2
	5	2S5016	TERMINAL	1
	6	9S2527	BODY	1
	7	2S5012	CAP	1
	8	5P905	CONTACT	1
	8	3S8183	BODY	1
Δ	9	4S8785	WIRE (10 gauge) 18 in.	
C	10	4S8787	WIRE (14 gauge) 18 in.	
	11	3B7255	BUSHING	1
	12	8M2772	CLIP	4
		2P6444	WIRE ASSEM.	1
			(Includes)	
	13	3S8183	BODY	1
		2S5015	TERMINAL	1
Δ	14	4S8760	TUBE 120 in.	
	15	1P5978	CONNECTOR	1
		1P5977	TERMINAL	1
		1P6958	WIRE ASSEM.	1
			(Includes)	
	16	2L8079	TERMINAL	1
Δ		4S8760	TUBE 13 in.	
		1P5977	TERMINAL	1
		1P5978	CONNECTOR	1
C	18	5P767	HOSE	
	19	8F8151	COCK	1
	20	8M8947	FUSE	1
		8M2771	CLIP	8
	21	310243	SCREW	8

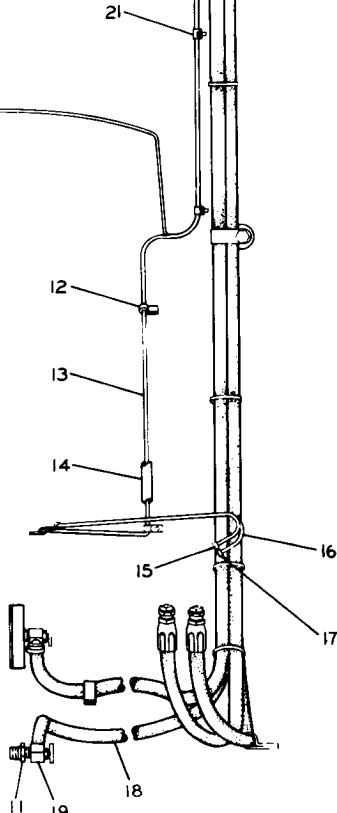

▲ ORDER BY THE FOOT  
 ● ORDER BY THE DECIMETRE  
 ○ ORDER LENGTH AS REQUIRED  
 C INDICATES CHANGE

147516

3P3832 MOUNTING MODIFICATIONS GROUP—Part 2 of 3—Type 2  
 Serial No. 11K5051 to 11K6440 inclusive. Part of 3P3835 Air  
 Conditioner Arrangement listed on Page 232A. AN ATTACHMENT

3P3832 MOUNTING MODIFICATIONS GROUP—Part 3 of 3—Type 2

Serial No. 11K5051 to 11K6440 inclusive

Part of 3P3835 Air Conditioner Arrangement listed on Page 232A. AN ATTACHMENT

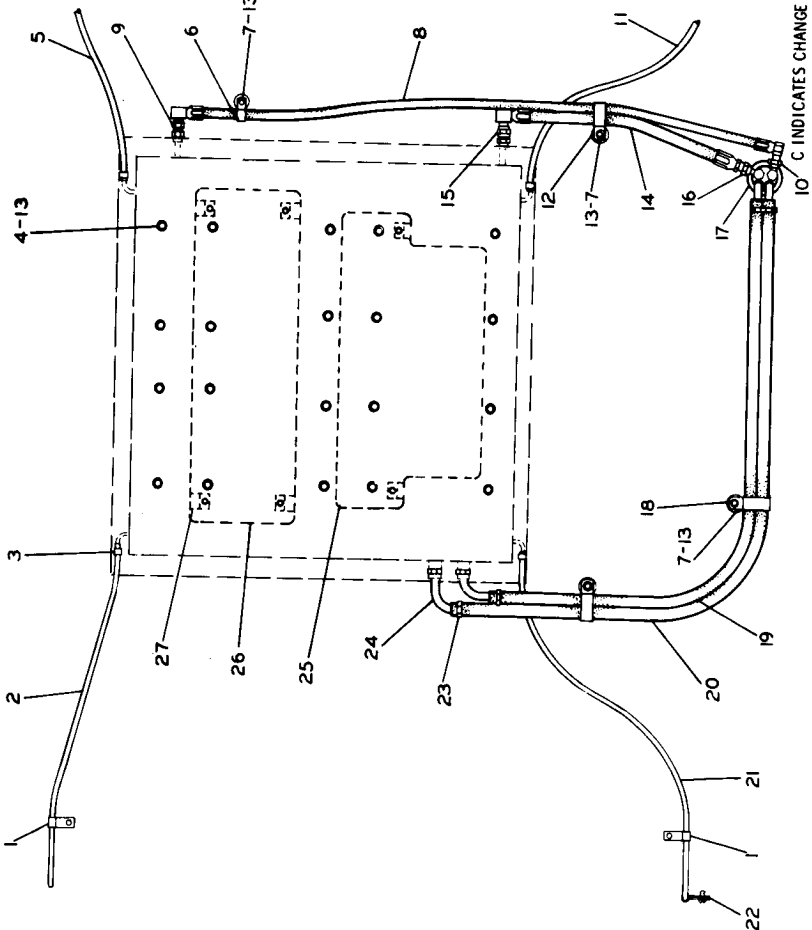

REF NO	PART NUMBER	DESCRIPTION	QTY
1	2S4616	CLAMP	4
2	5P757	TUBE---21.08 dm(83 in.)	4
3	1P4278	CLAMP	4
4	5L591	BOLT	20
5	5P757	TUBE---19.81 dm(79 in.)	1
6	4S1962	CLIP	4
7	5S09	BOLT	4
8	4K2542	BOSS	4
9	5P1036	HOSE	1
10	5P481	COUPLING	1
11	5P480	COUPLING	1
12	6D1641	CLIP	1
13	3B4506	LOCKWASHER	24
14	5P1037	HOSE	1
15	5P487	COUPLING	1
16	5P484	COUPLING	1
17	8D482	GROMMET	1
18	6M6782	CLIP	2
19	5P767	HOSE	1
20	5P767	HOSE	1
21	5P757	TUBE---22.23 dm(87.5 in.)	12
22	2H7829	CLIP	12
23	1P5121	SCREW	12
24	1P3956	TUBE	10
25	3P3927	FLANGE ASSEM. (Includes)	4
26	3P3922	STRIP	1
27	2N2258	RIVET	14
	3P3924	FLANGE ASSEM. (Includes)	14
	3P3922	STRIP	14
	2N2258	RIVET	14
	3P7536	BRACKET	6
	1P5121	SCREW	6
	2N2258	RIVET	6

ORDER BY THE DECIMETRE  
ORDER LENGTH AS REQUIRED

10 C INDICATES CHANGE

147517



6P2931 MOUNTING MODIFICATIONS GROUP—Part 2 of 4  
 Part of 6P2932 Air Conditioner Arrangement listed on Page 232A

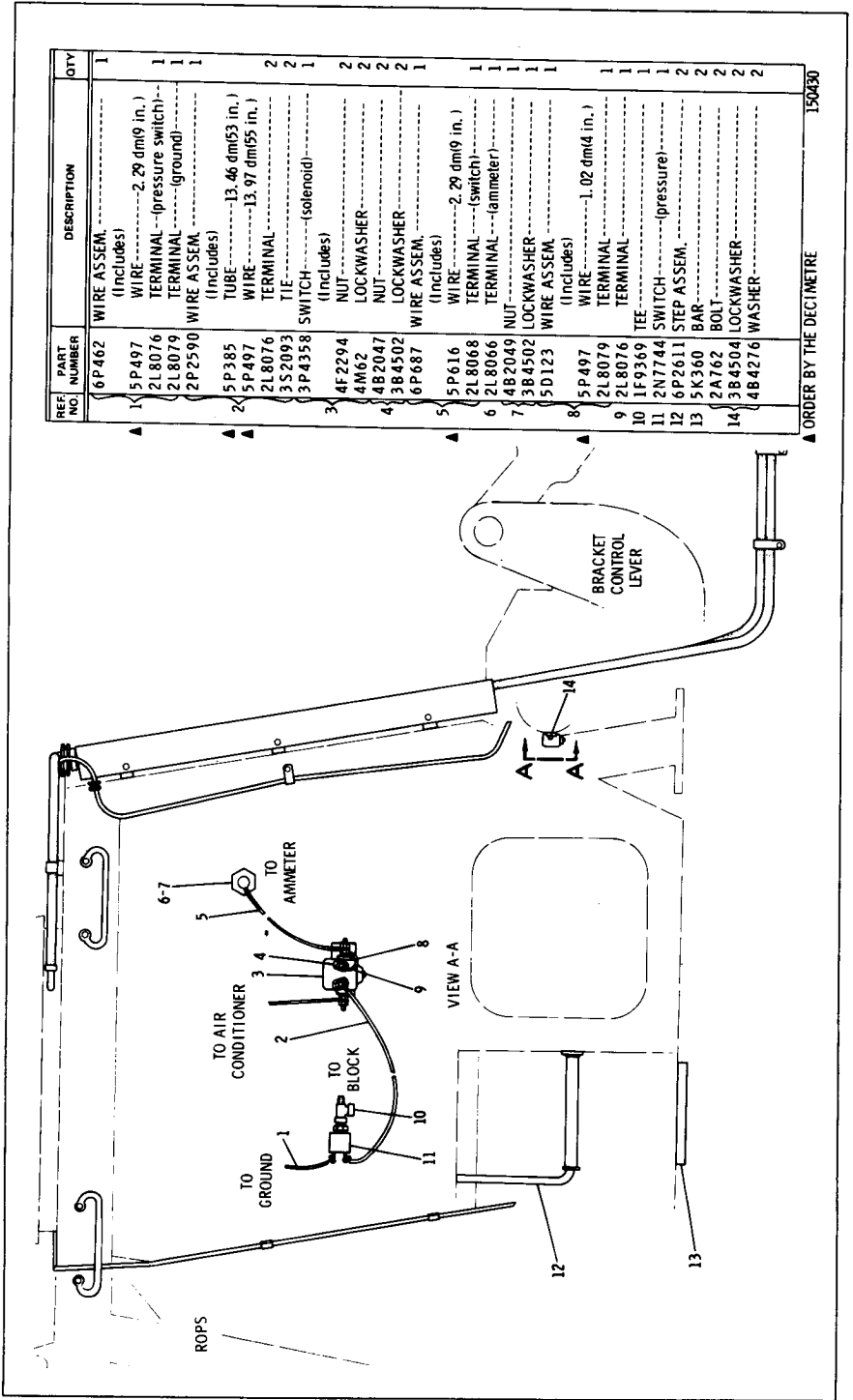

REF NO.	PART NUMBER	DESCRIPTION	QTY
1	6P462	WIRE ASSEM. (Includes)	1
2	5P497	WIRE---2.29 dm(9 in.)	1
3	2L8076	TERMINAL---(pressure switch)	1
4	2L8079	TERMINAL---(ground)	1
5	2P2590	WIRE ASSEM. (Includes)	1
6	5P385	TUBE---13.46 dm(53 in.)	2
7	5P497	WIRE---13.97 dm(55 in.)	2
8	2L8076	TERMINAL	1
9	3S2093	TIE---(solenoid)	1
10	3P4358	SWITCH (Includes)	2
11	4F2294	NUT	2
12	4M62	LOCKWASHER	2
13	4B2047	NUT	2
14	3B4502	LOCKWASHER	2
15	6P687	WIRE ASSEM. (Includes)	1
16	5P616	WIRE---2.29 dm(9 in.)	1
17	2L8068	TERMINAL---(switch)	1
18	2L8066	TERMINAL---(ammeter)	1
19	4B2049	NUT	1
20	3B4502	LOCKWASHER	1
21	3D123	WIRE ASSEM. (Includes)	1
22	5P497	WIRE---1.02 dm(4 in.)	1
23	2L8079	TERMINAL	1
24	2L8076	TERMINAL	1
25	1F9369	TEE	1
26	2N7744	SWITCH---(pressure)	1
27	6P2611	STEP ASSEM.	2
28	5K360	BAR	2
29	2A762	BOLT	2
30	3B4504	LOCKWASHER	2
31	4B4276	WASHER	2

▲ ORDER BY THE DECIMETRE 150490

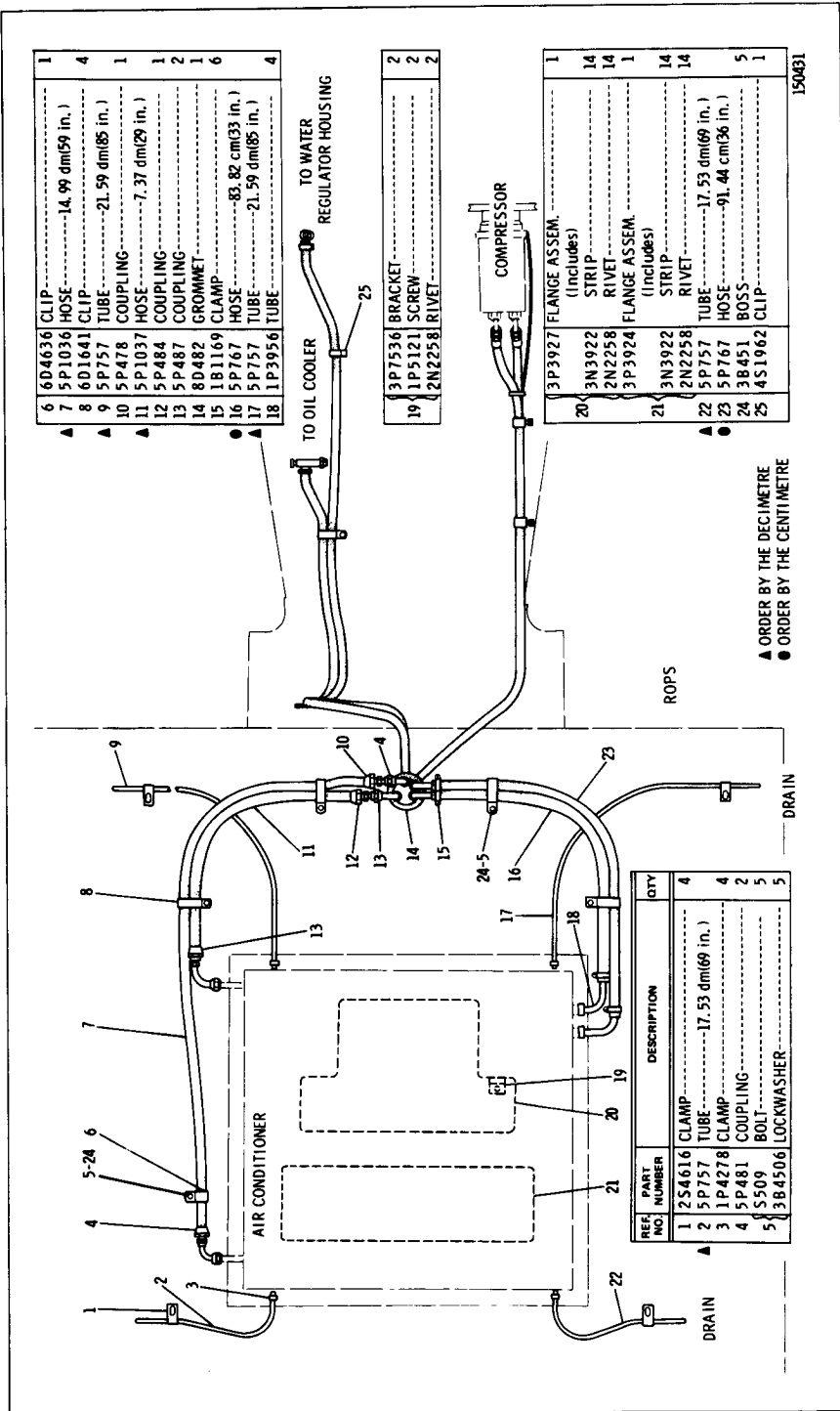

6	6D4636	CLIP	1
7	5P1036	HOSE	14.99 dm(59 in.)
8	6D1641	CLIP	4
9	5P757	TUBE	21.59 dm(85 in.)
10	5P478	COUPLING	1
11	5P1037	HOSE	7.37 dm(29 in.)
12	5P484	COUPLING	1
13	5P487	COUPLING	2
14	8D482	GROMMET	1
15	1B1169	CLAMP	6
16	5P767	HOSE	83.82 cm(33 in.)
17	5P757	TUBE	21.59 dm(85 in.)
18	1P3956	TUBE	4

3	P7536	BRACKET	2
19	1P5121	SCREW	2
2	2N2258	RIVET	2

1	3P3927	FLANGE ASSEM. (Includes)	1
14	3N3922	STRIP	14
14	2N2258	RIVET	14
1	3P3924	FLANGE ASSEM. (Includes)	1
14	3N3922	STRIP	14
14	2N2258	RIVET	14
14	5P757	TUBE	17.53 dm(69 in.)
5	5P767	HOSE	91.44 cm(36 in.)
5	3B451	BOSS	5
1	4S1962	CLIP	1

REF. NO.	PART NUMBER	DESCRIPTION	QTY
1	2S4616	CLAMP	4
2	5P757	TUBE	17.53 dm(69 in.)
3	1P4278	CLAMP	4
4	5P481	COUPLING	5
5	S509	BOLT	2
5	3B4506	LOCKWASHER	5

▲ ORDER BY THE DECIMETRE  
● ORDER BY THE CENTIMETRE

6P2931 MOUNTING MODIFICATIONS GROUP—Part 3 of 4  
Part of 6P2932 Air Conditioner Arrangement listed on Page 232A

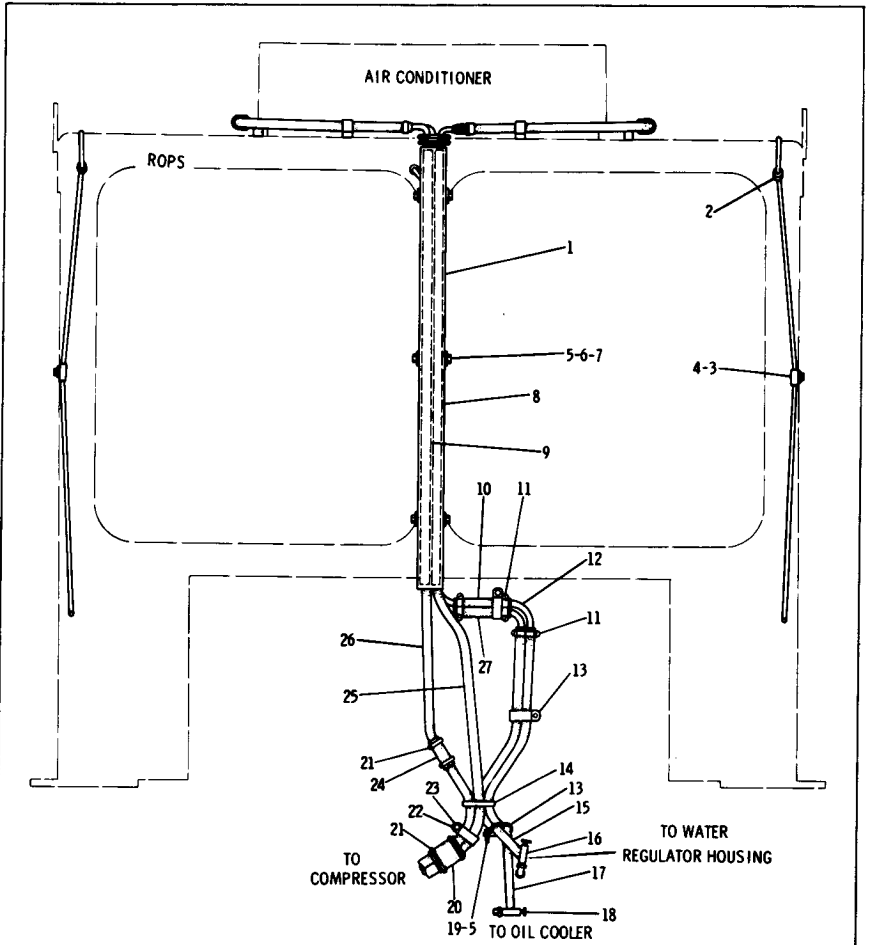

REF. NO.	PART NUMBER	DESCRIPTION	QTY
1	6P1710	COVER-----	1
2	3F1240	GROMMET-----	3
3	2H7829	CLIP-----	2
4	2H3755	BOLT-----	2
4	1D4716	NUT-----	2
4	3B4505	LOCKWASHER-----	2
5	5509	BOLT-----	8
6	5P1075	WASHER-----	6
6	6P817	BRACKET ASSEM.-----	3
7		(Each Includes)	
7	9F2978	NUT----- (weld)-----	2
● 8	5P767	HOSE-----106.84 cm(46 in.)	1
● 9	5P767	HOSE-----106.84 cm(46 in.)	1
● 10	5P767	HOSE-----20.32 cm(8 in.)	1
11	1B1169	CLAMP-----	12
12	1P3956	TUBE-----	4
13	6D1641	CLIP-----	3
14	7K1181	STRAP-----	1

● 15	5P767	HOSE-----182.88 cm(72 in.)	1
16	8F8151	COCK-----	1
16	32143	ELBOW-----	1
16	6B4661	BUSHING-----	1
● 17	5P767	HOSE-----132.08 cm(52 in.)	1
18	1V6585	VALVE-----	1
18	6B1628	BUSHING-----	1
19	3B4506	LOCKWASHER-----	2
▲ 20	5P1286	SEAL-----2.03 dm(8 in.)	1
21	3S2093	TIE-----	4
22	6D4534	CLIP-----	1
23	9S1366	BOLT-----	1
23	7S3820	SPACER-----	1
▲ 24	5P1286	SEAL-----1.52 dm(6 in.)	1
▲ 25	5P1037	HOSE-----33.53 dm(132 in.)	1
25	5P488	COUPLING-----	1
▲ 26	5P1036	HOSE-----33.53 dm(132 in.)	1
26	5P482	COUPLING-----	1
● 27	5P767	HOSE-----20.32 cm(8 in.)	1

▲ ORDER BY THE DECIMETRE

● ORDER BY THE CENTIMETRE

205525

6P2931 MOUNTING MODIFICATIONS GROUP—Part 4 of 4  
Part of 6P2932 Air Conditioner Arrangement listed on Page 232A

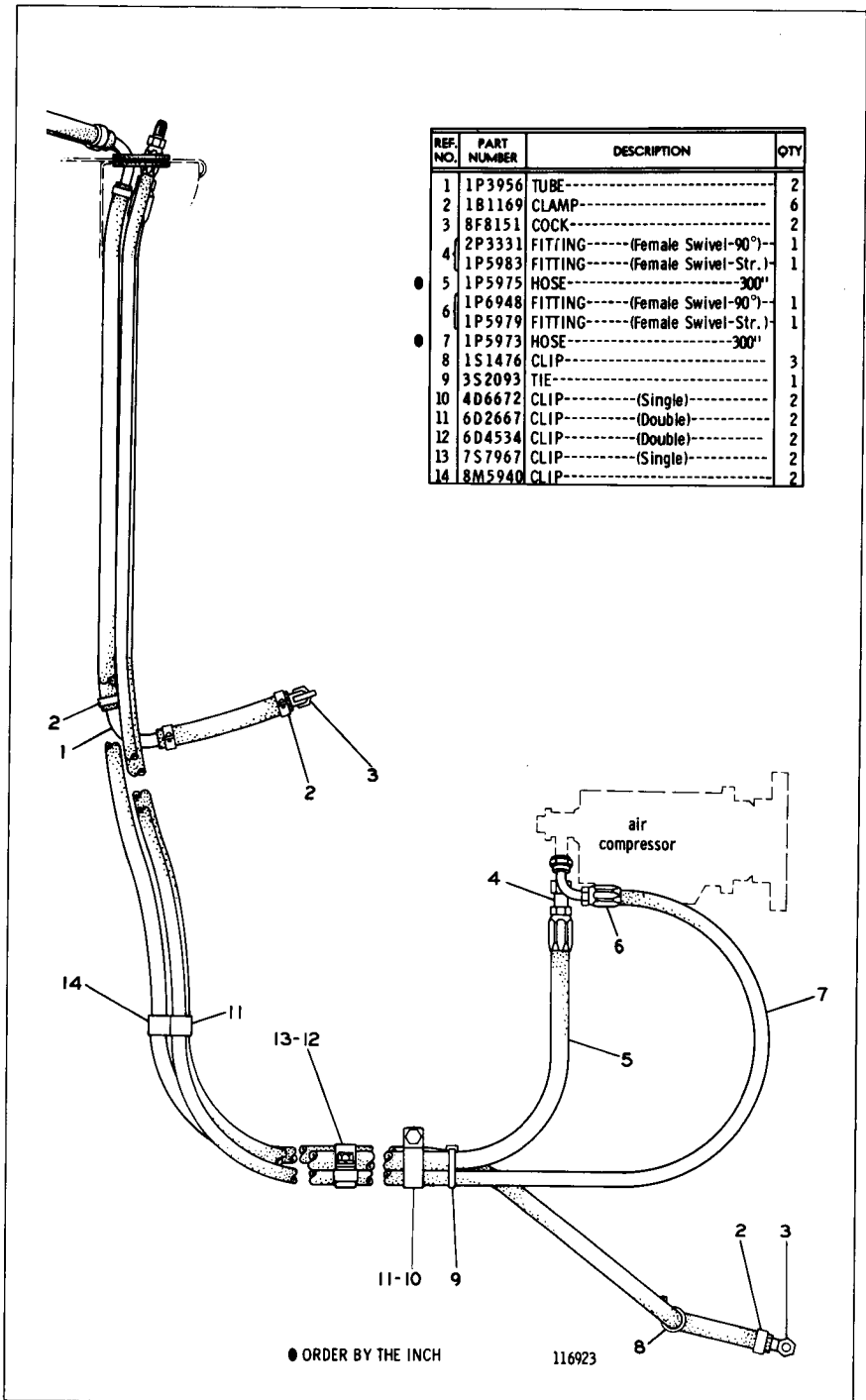

2P3153 MOUNTING MODIFICATIONS GROUP—Part 1 of 3  
 Part of 2P3154 Air Conditioner Arrangement listed on Page 233



CATERPILLAR 977L TRAXCAVATOR

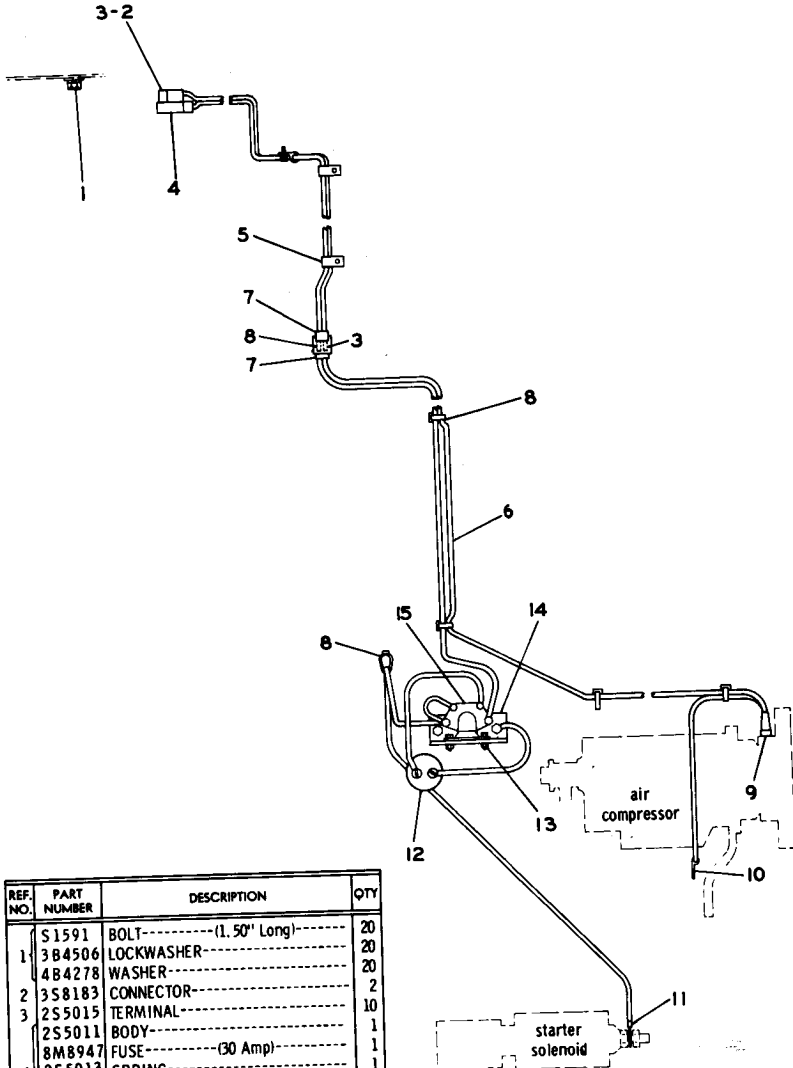

REF. NO.	PART NUMBER	DESCRIPTION	QTY
1	S1591	BOLT----- (1.50" Long)-----	20
	3B4506	LOCKWASHER-----	20
	4B4278	WASHER-----	20
2	3S8183	CONNECTOR-----	2
	2S5015	TERMINAL-----	10
3	2S5011	BODY-----	1
	8M8947	FUSE----- (30 Amp)-----	1
	2S5013	SPRING-----	1
	2S5012	CAP-----	2
4	2S8708	CONTACT-----	2
	8M2771	CLIP-----	6
	4S8760	TUBE----- 360'	
6	4S8785	WIRE----- 360'	
	9S2527	BODY----- (Connector)-----	4
7	3S2093	TIE-----	7
	1P5977	TERMINAL-----	2
9	1P5978	CONNECTOR-----	2
	2L8064	TERMINAL----- (No. 6 Screw)-----	3
10	2L8066	TERMINAL----- (No. 10 Screw)-----	7
	2L8069	TERMINAL----- (.375" Dia. Screw)-----	3

11	2L8071	TERMINAL----- (.5" Dia. Screw)-----	2
12	4D4785	SWITCH-----	1
	5B7589	FITTING-----	1
13	1F1344	NUT-----	2
	1H2387	BOLT-----	2
14	4B2047	NUT-----	2
	8F1434	LOCKWASHER-----	2
	4B4274	WASHER-----	2
15	1P7109	BRACKET-----	1
	1P5976	RELAY-----	1

C INDICATES CHANGE  
 ▲ ORDER BY THE FOOT

116924

2P3153 MOUNTING MODIFICATIONS GROUP—Part 3 of 3  
Part of 2P3154 Air Conditioner Arrangement listed on Page 233

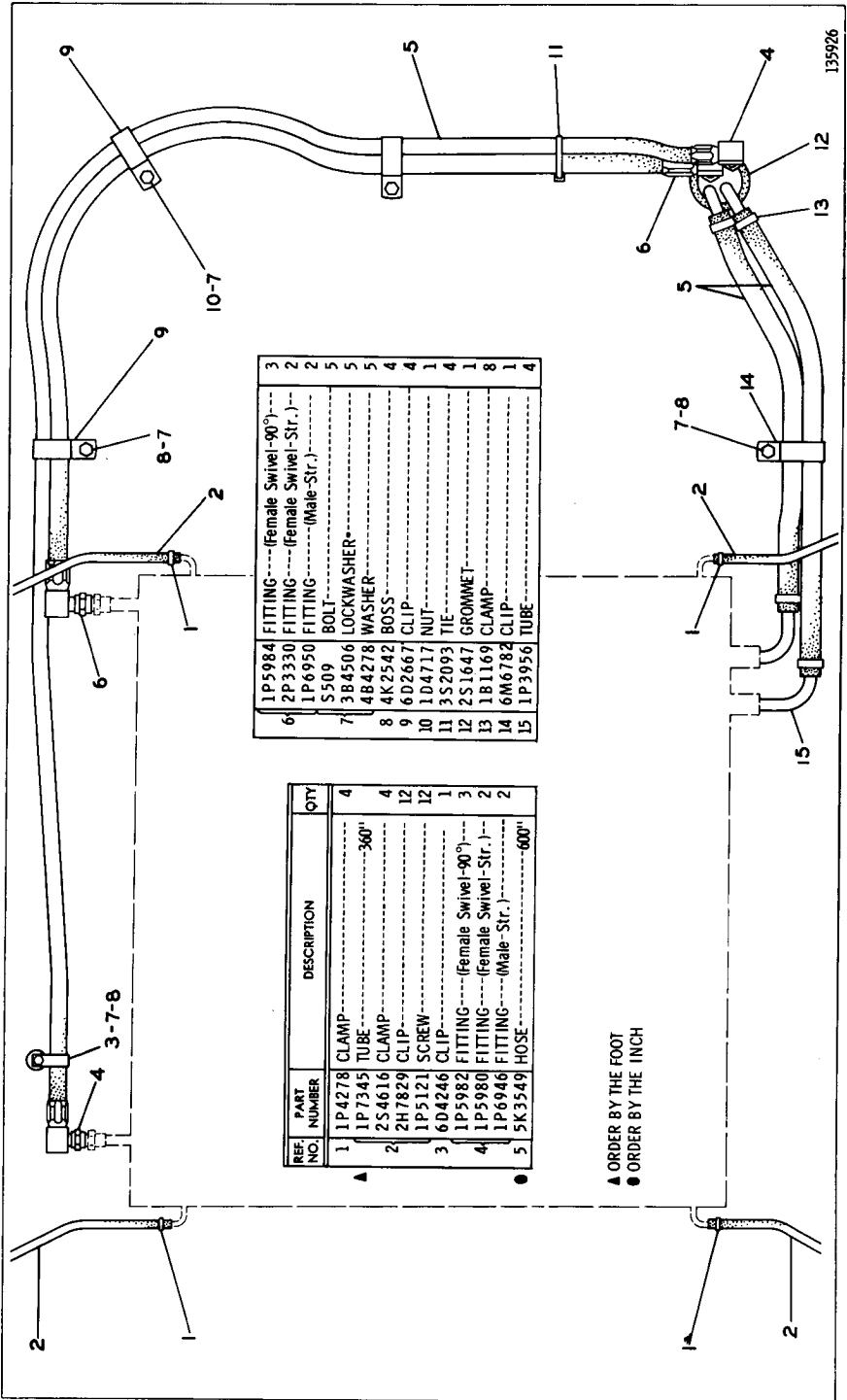

135926

1	1P5984	FITTING---(Female Swivel-90°)---	3
2	2P3330	FITTING---(Female Swivel-Str.)---	2
3	1P6950	FITTING---(Male-Str.)---	2
4	5509	BOLT---	5
5	3B4506	LOCKWASHER---	5
6	4B4278	WASHER---	5
7	4K2542	BOSS---	4
8	6D2667	CLIP---	4
9	1D4717	NUT---	1
10	3S2093	TIE---	1
11	2S1647	GROMMET---	4
12	1B1169	CLAMP---	1
13	6M6782	CLIP---	8
14	1P3956	TUBE---	1
15			4

REF. NO.	PART NUMBER	DESCRIPTION	QTY
1	1P4278	CLAMP---	4
2	1P7345	TUBE---360°---	4
3	2S4616	CLAMP---	4
4	2H7829	CLIP---	12
5	1P5121	SCREW---	12
6	6D4246	CLIP---	1
7	1P5982	FITTING---(Female Swivel-90°)---	3
8	1P5980	FITTING---(Female Swivel-Str.)---	2
9	1P6946	FITTING---(Male-Str.)---	2
10	5K3549	HOSE---600°---	2

▲ ORDER BY THE FOOT  
● ORDER BY THE INCH

REF. NO.	PART NUMBER	DESCRIPTION	QTY
1	3P2312	SHIM-----(Use as Required)	8
2	2P8515	STRIP-----	4
3	1D4637	BOLT-----	14
4	3K5234	WASHER-----	26
5	1D4638	BOLT-----	2

13	1B2588	BOSS-----	2
14	1S8241	BOSS-----	4
15	4D9376	BOSS-----	2
16	5B8855	PLATE-----	1

17	6F3259	LUG-----	1
18	5M3012	LUG-----	3
19	3P4188	GRAB IRON----- (R. H.)	1
19	3P4189	GRAB IRON----- (L. H.)	1
20	3P2307	PLATE----- (R. H.)	1
20	3P2308	PLATE----- (L. H.)	1
21	7K3206	REINFORCEMENT-----	2
22	7K4609	PLATE-----	2
23	6K2107	BLOCK-----	4
24	3S5275	BLOCK-----	2
25	5K5878	SUPPORT ASSEM.-----	1
26	7K4610	PLATE-----	2
27	6K2111	BRACKET-----	2
28	2J2411	BLOCK-----	6
29	7K2716	ANGLE-----	2
30	3S4893	STUD-----	6
30	7F482	NUT-----	6
30	2P8961	SPACER-----	6
31	2P8536	SUPPORT ASSEM.----- (R. H.)	1
31	2P8537	SUPPORT ASSEM.----- (L. H.)	1
32	6M3947	STUD-----	2
32	6K3632	NUT-----	2
33	2P8514	SPACER-----	2
33	2P8470	PLATE-----	1
34	8S9093	BOLT-----	10
34	4B4285	WASHER-----	10

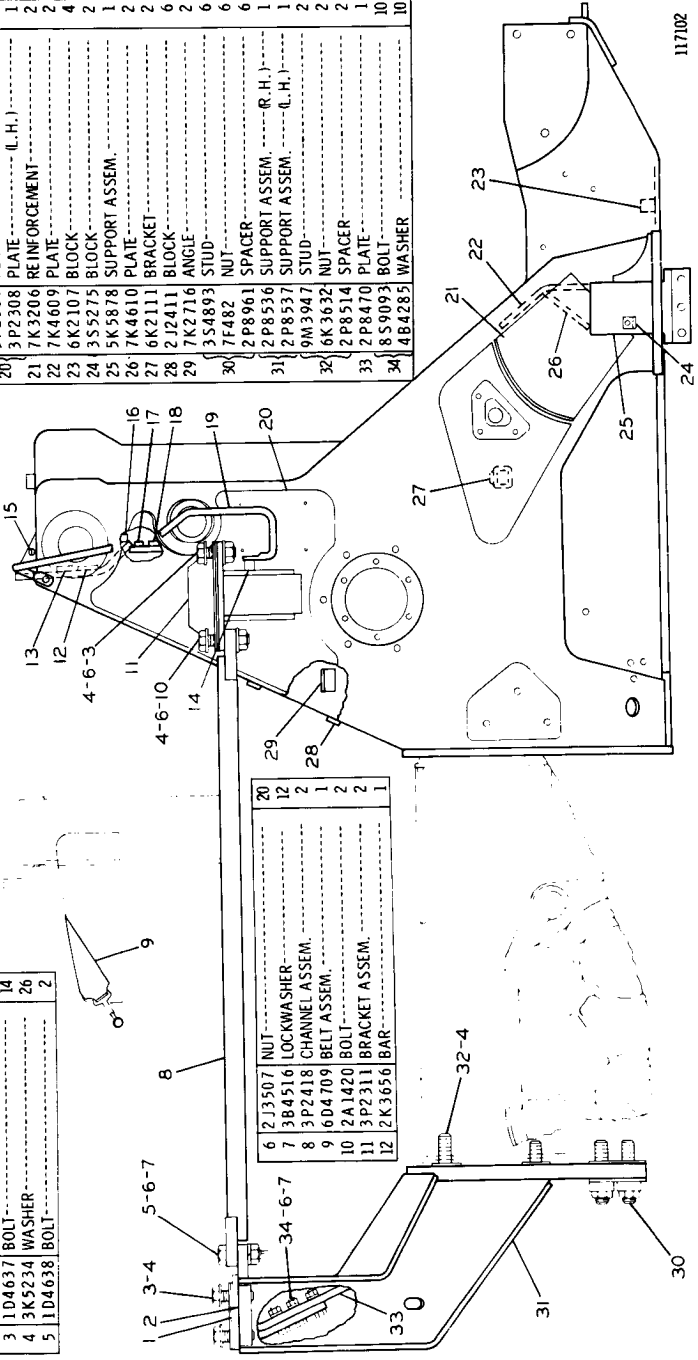

2P8538 MOUNTING GROUP—Factory Installation—Type 1  
FOR USE WITH ROLL-OVER PROTECTIVE STRUCTURE  
AN ATTACHMENT

117102

2P8538 MOUNTING GROUP—Factory Installation—Type 2  
FOR USE WITH ROLL-OVER PROTECTIVE STRUCTURE  
AN ATTACHMENT

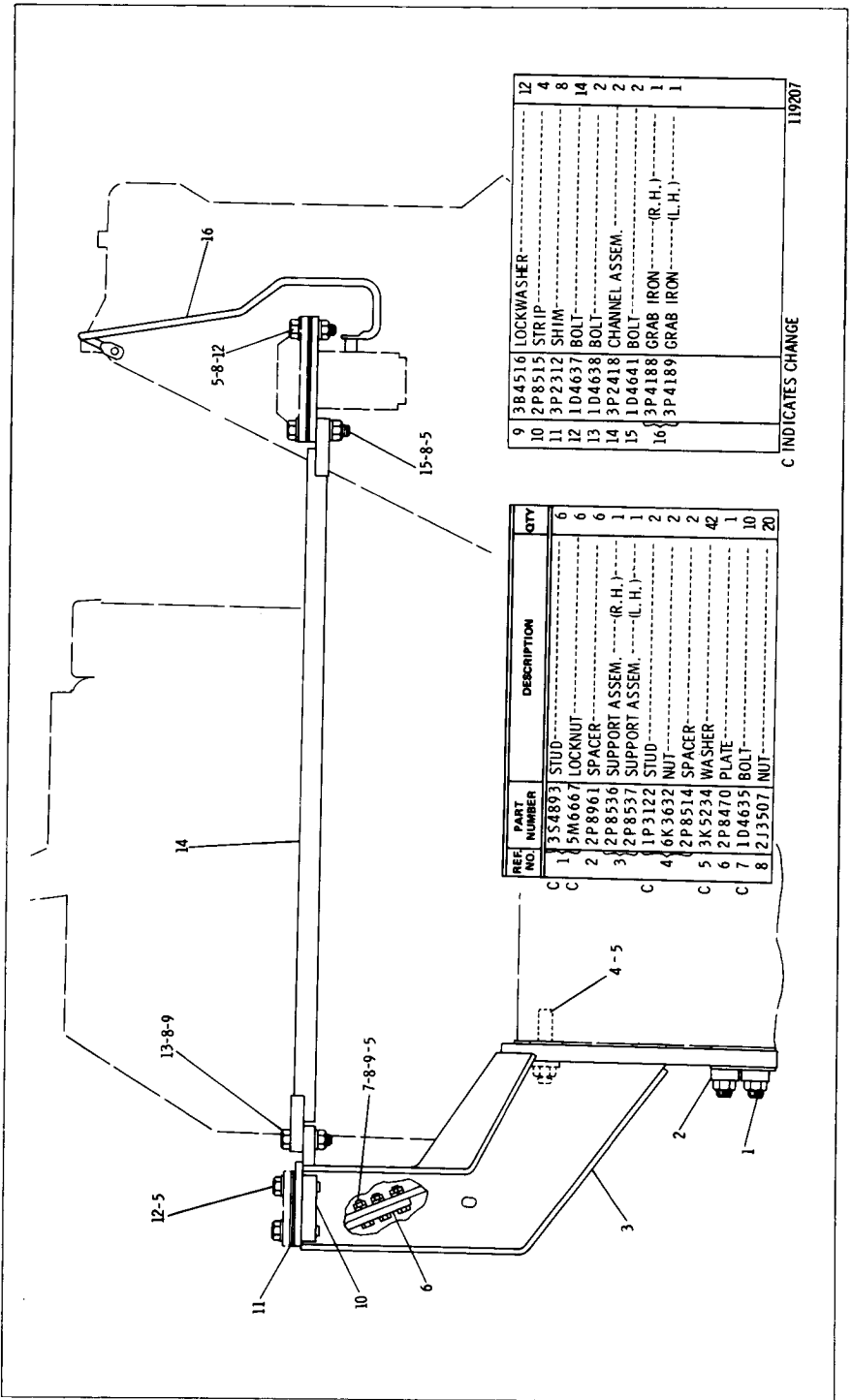

REF. NO.	PART NUMBER	DESCRIPTION	QTY
1	3S4893	STUD	6
2	5M6667	LOCKNUT	6
3	2P8961	SPACER	6
4	2P8536	SUPPORT ASSEM. ---(R. H.)---	1
5	2P8537	SUPPORT ASSEM. ---(L. H.)---	1
6	1P3122	STUD	2
7	6K3632	NUT	2
8	2P8514	SPACER	2
9	3K5234	WASHER	42
10	2P8470	PLATE	1
11	1D4635	BOLT	10
12	2J3507	NUT	20

9	3B4516	LOCKWASHER	12
10	2P8515	STRIP	4
11	3P2312	SHIM	8
12	1D4637	BOLT	14
13	1D4638	BOLT	2
14	3P2418	CHANNEL ASSEM.	2
15	1D4641	BOLT	2
16	3P4188	GRAB IRON --- (R. H.) ---	1
		GRAB IRON --- (L. H.) ---	1

C INDICATES CHANGE

119207

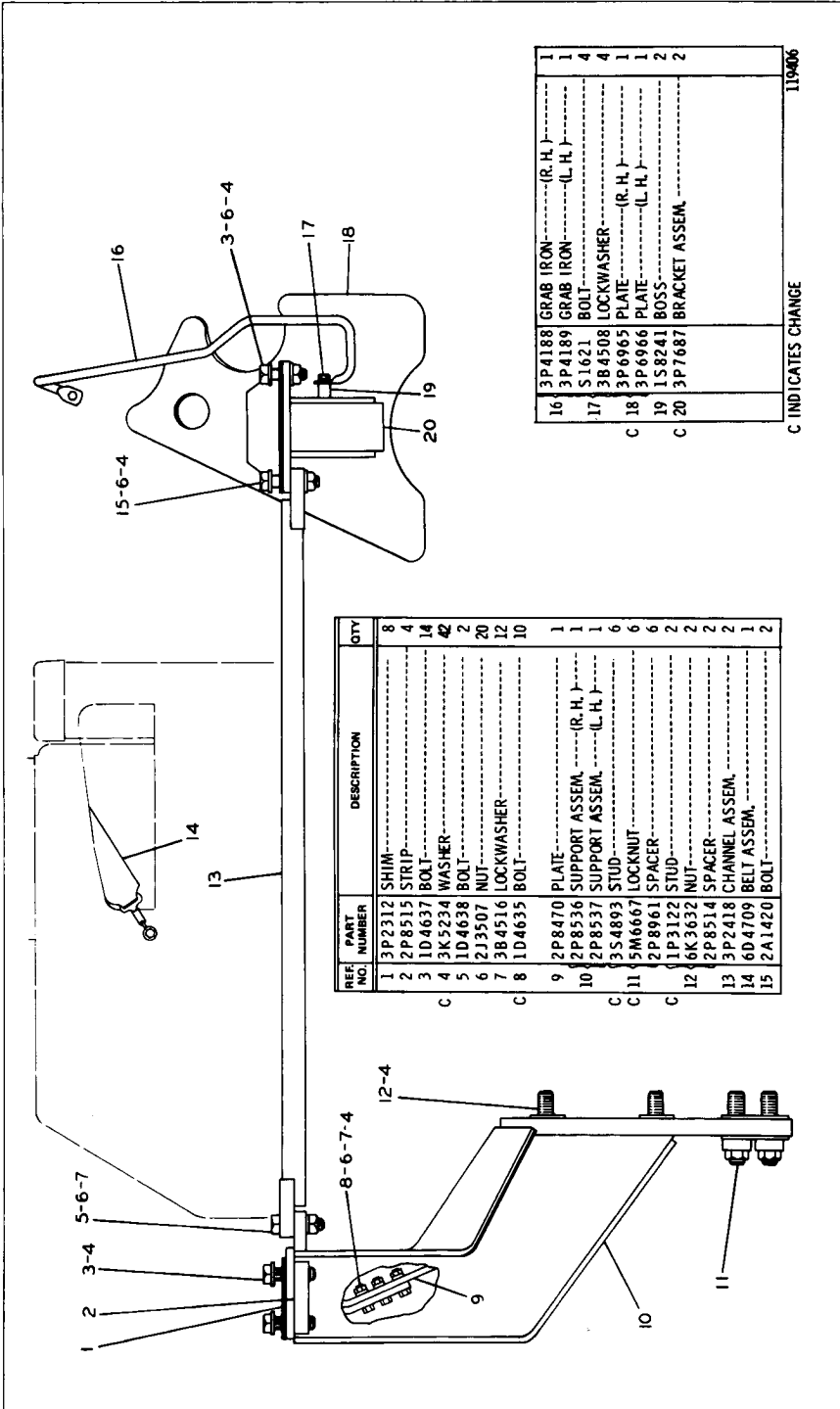

REF. NO.	PART NUMBER	DESCRIPTION	QTY
1	3P2312	SHIM-----	8
2	2P8515	STRIP-----	4
3	1D4637	BOLT-----	4
4	3K5234	WASHER-----	14
5	1D4638	BOLT-----	42
6	2J3507	NUT-----	2
7	3B4516	LOCKWASHER-----	20
8	1D4635	BOLT-----	12
9	2P8470	PLATE-----	10
10	2P8536	SUPPORT ASSEM.-----(R. H.)-----	1
11	2P8537	SUPPORT ASSEM.-----(L. H.)-----	1
12	3S4893	STUD-----	6
13	5M6667	LOCKNUT-----	6
14	2P8961	SPACER-----	6
15	1P3122	STUD-----	2
16	6K3632	NUT-----	2
17	2P8514	SPACER-----	2
18	3P2418	CHANNEL ASSEM.---	2
19	6D4709	BELT ASSEM.---	2
20	2A1420	BOLT-----	1

16	3P4188	GRAB IRON------(R. H.)-----	1
17	3P4189	GRAB IRON------(L. H.)-----	1
18	S1621	BOLT-----	4
19	3B4508	LOCKWASHER-----	4
20	3P6965	PLATE------(R. H.)-----	1
21	3P6966	PLATE------(L. H.)-----	1
22	1S8241	BOSS-----	2
23	3P7687	BRACKET ASSEM.---	2

C INDICATES CHANGE 119406

2P8965 MOUNTING GROUP—Field Installation  
FOR USE WITH ROLL-OVER PROTECTIVE STRUCTURE

CONSISTS OF:		PAGE
1	3P3201 CAB LINER GROUP.....	248B , 248C , 248D
1	3P9933 ROLL-OVER PROTECTIVE SYSTEM.....	248E

3P5982 ROLL-OVER PROTECTIVE SYSTEM—Enclosed  
FOR USE WITH 2P8538 OR 2P8965 MOUNTING GROUPS SHOWN  
ON PAGES 246, 247 AND 248. AN ATTACHMENT

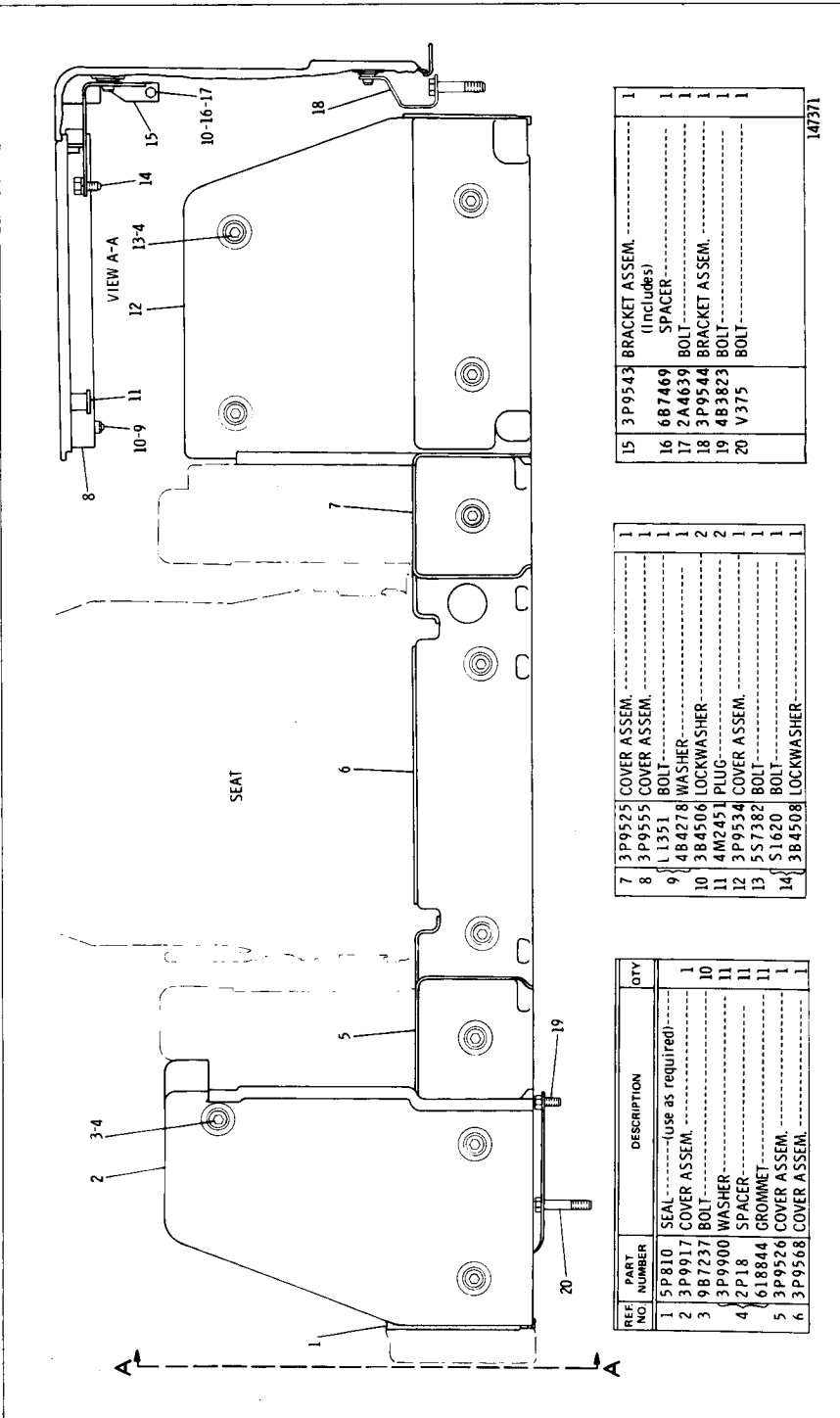

REF. NO.	PART NUMBER	DESCRIPTION	QTY
1	5P810	SEAL----- (Use as required)	1
2	3P917	COVER ASSEM.-----	10
3	98737	BOLT-----	11
4	3P990	WASHER-----	11
4	2P18	SPACER-----	11
5	618844	GROMMET-----	11
5	3P9526	COVER ASSEM.-----	1
6	3P9568	COVER ASSEM.-----	1

7	3P9525	COVER ASSEM.-----	1
8	3P9555	COVER ASSEM.-----	1
9	11351	BOLT-----	1
9	484278	WASHER-----	1
10	384506	LOCKWASHER-----	2
11	4M2451	PLUG-----	2
12	3P9534	COVER ASSEM.-----	1
13	5S7382	BOLT-----	1
14	51620	BOLT-----	1
14	384508	LOCKWASHER-----	1

15	3P9543	BRACKET ASSEM.----- (Includes)	1
16	6B7469	SPACER-----	1
17	2A4639	BOLT-----	1
18	3P9544	BRACKET ASSEM.-----	1
19	4B3823	BOLT-----	1
20	V375	BOLT-----	1

147371

3P3201 CAB LINER GROUP—Part 1 of 3  
 Part of 3P5982 Roll-Over Protective System listed on Page 248A  
 AN ATTACHMENT

3P3201 CAB LINER GROUP—Part 2 of 3  
 Part of 3P5982 Roll-Over Protective System listed on Page 248A  
 AN ATTACHMENT

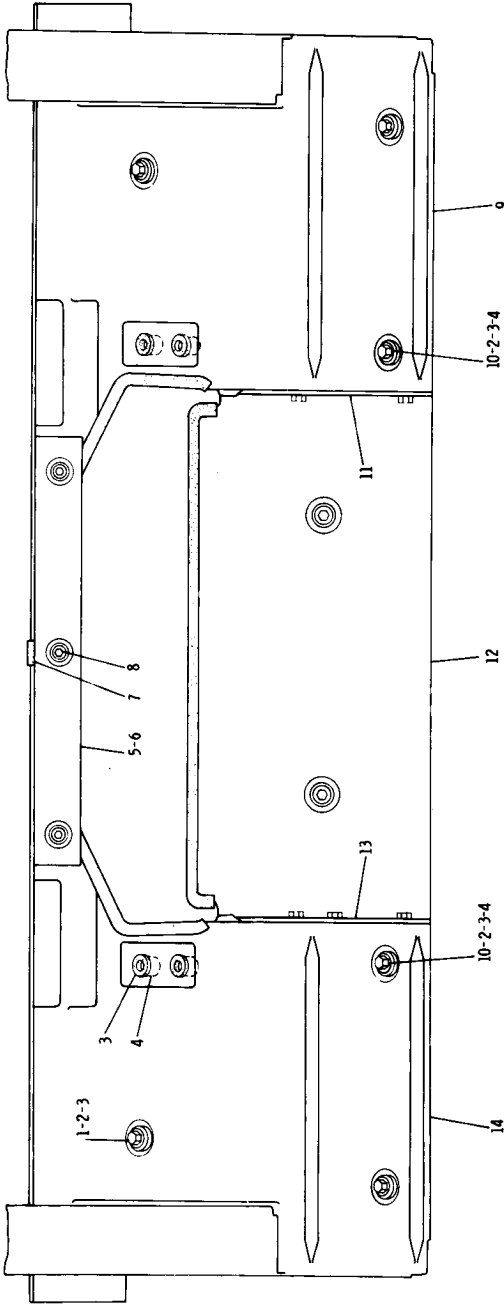

REF. NO.	PART NUMBER	DESCRIPTION	QTY
1	9B7237	BOLT	11
2	2P18	SPACER	11
3	3P9900	WASHER	13
4	618844	GROMMET	17
5	3P9726	SPACER	6
	3P9913	COVER ASSEM.	1

6	5P2061	SEAL	(Use as required)
7	5P799	SEAL	(Use as required)
	1H3337	BOLT	3
8	3P9901	WASHER	3
	3P9553	SPACER	3
9	3P9554	GROMMET	3
	3P9903	COVER ASSEM.	1
10	5S7283	BOLT	2

11	3P9539	COVER ASSEM.	1
12	3P9551	COVER ASSEM.	1
13	6P260	COVER ASSEM.	1
14	3P9902	COVER ASSEM.	1

147372



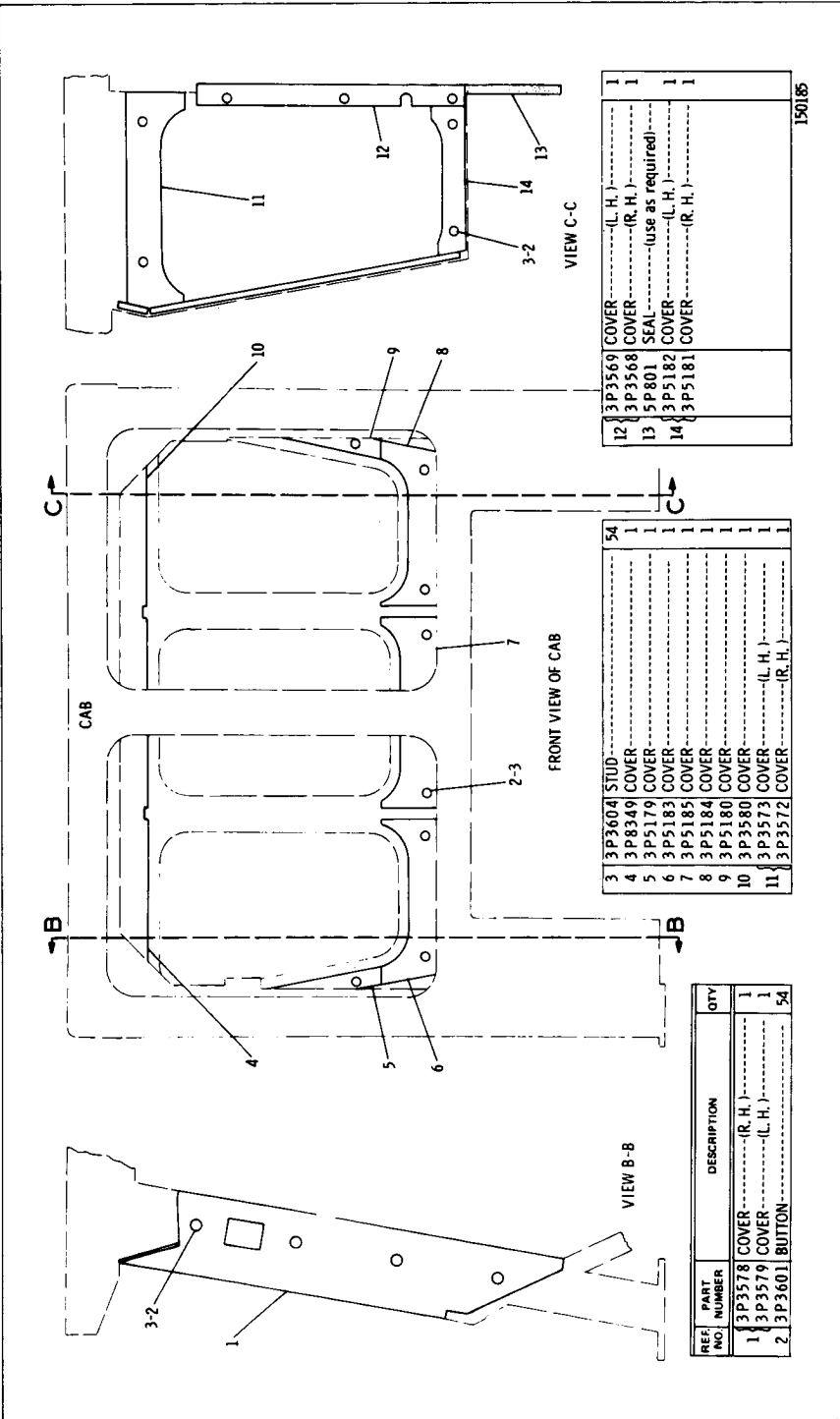

3P3201 CAB LINER GROUP—Part 3 of 3  
 Part of 3P5982 Roll-Over Protective System listed on Page 248A  
 AN ATTACHMENT

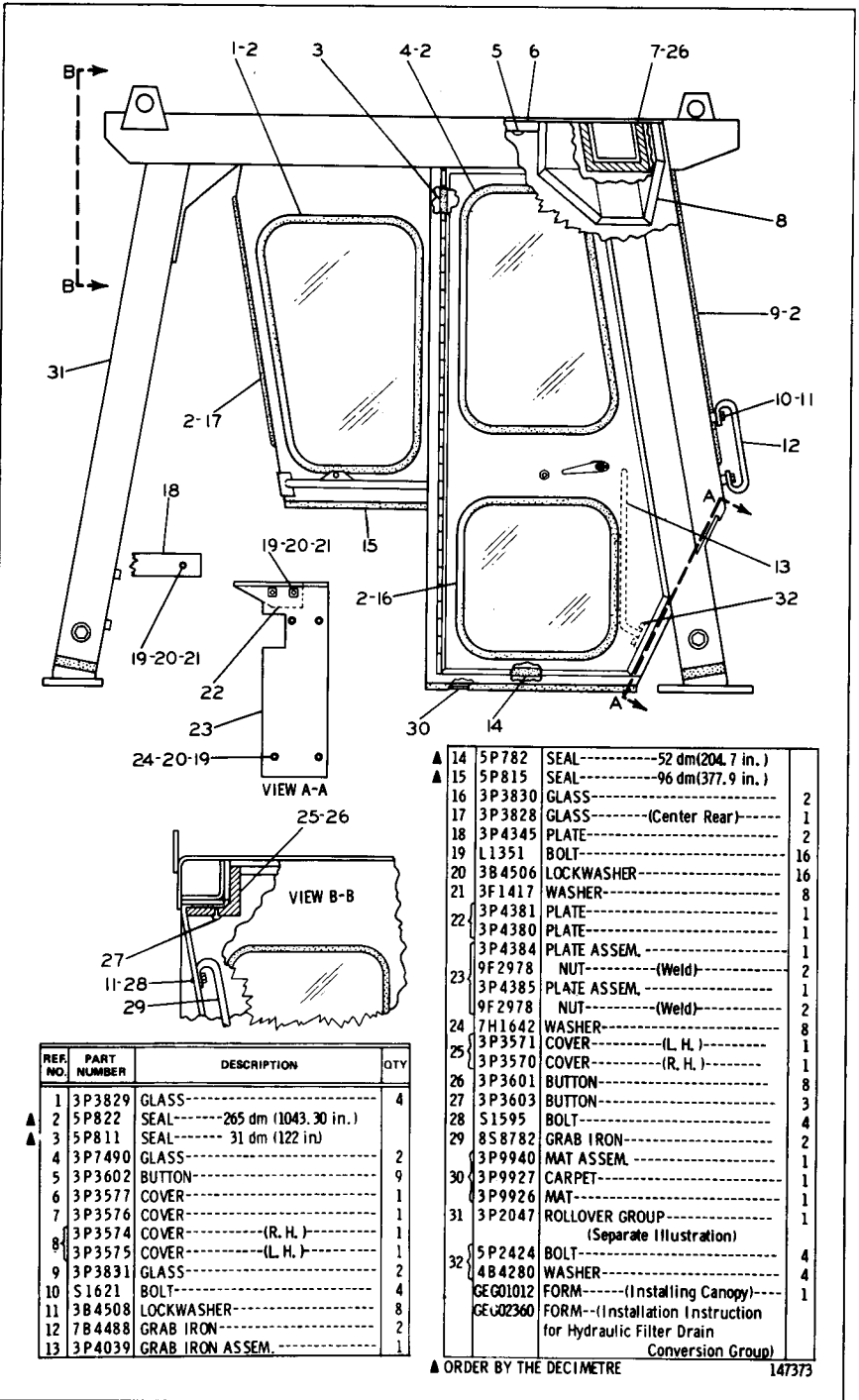

▲ 14	5P782	SEAL-----	52 dm(204.7 in.)	
▲ 15	5P815	SEAL-----	96 dm(377.9 in.)	
16	3P3830	GLASS-----		2
17	3P3828	GLASS-----	(Center Rear)	1
18	3P4345	PLATE-----		2
19	L1351	BOLT-----		16
20	3B4506	LOCKWASHER-----		16
21	3F1417	WASHER-----		8
22	3P4381	PLATE-----		1
	3P4380	PLATE-----		1
	3P4384	PLATE ASSEM.-----		1
23	9F2978	NUT-----	(Weld)	2
	3P4385	PLATE ASSEM.-----		1
	9F2978	NUT-----	(Weld)	2
24	7H1642	WASHER-----		8
	3P3571	COVER-----	(L. H.)	1
25	3P3570	COVER-----	(R. H.)	1
26	3P3601	BUTTON-----		8
27	3P3603	BUTTON-----		3
28	S1595	BOLT-----		4
29	8S8782	GRAB IRON-----		2
	3P9940	MAT ASSEM.-----		1
30	3P9927	CARPET-----		1
	3P9926	MAT-----		1
31	3P2047	ROLLOVER GROUP-----		1
		(Separate Illustration)		
	5P2424	BOLT-----		4
32	4B4280	WASHER-----		4
	GEG01012	FORM-----	(Installing Canopy)	1
	GEG02360	FORM-----	(Installation Instruction for Hydraulic Filter Drain Conversion Group)	

REF. NO.	PART NUMBER	DESCRIPTION	QTY
▲ 1	3P3829	GLASS-----	4
▲ 2	5P822	SEAL-----	265 dm (1043.30 in.)
▲ 3	5P811	SEAL-----	31 dm (122 in)
4	3P7490	GLASS-----	2
5	3P3602	BUTTON-----	9
6	3P3577	COVER-----	1
7	3P3576	COVER-----	1
8	3P3574	COVER-----	(R. H.)
	3P3575	COVER-----	(L. H.)
9	3P3831	GLASS-----	2
10	S1621	BOLT-----	4
11	3B4508	LOCKWASHER-----	8
12	7B4488	GRAB IRON-----	2
13	3P4039	GRAB IRON ASSEM.-----	1

▲ ORDER BY THE DECIMETRE 147373

3P9933 ROLL-OVER PROTECTIVE SYSTEM—Type 1  
 Part of 3P5982 Roll-Over Protective System listed on Page 248A. 3P2047 Roll-Over Protective Structure parts are shown on Page 250. AN ATTACHMENT

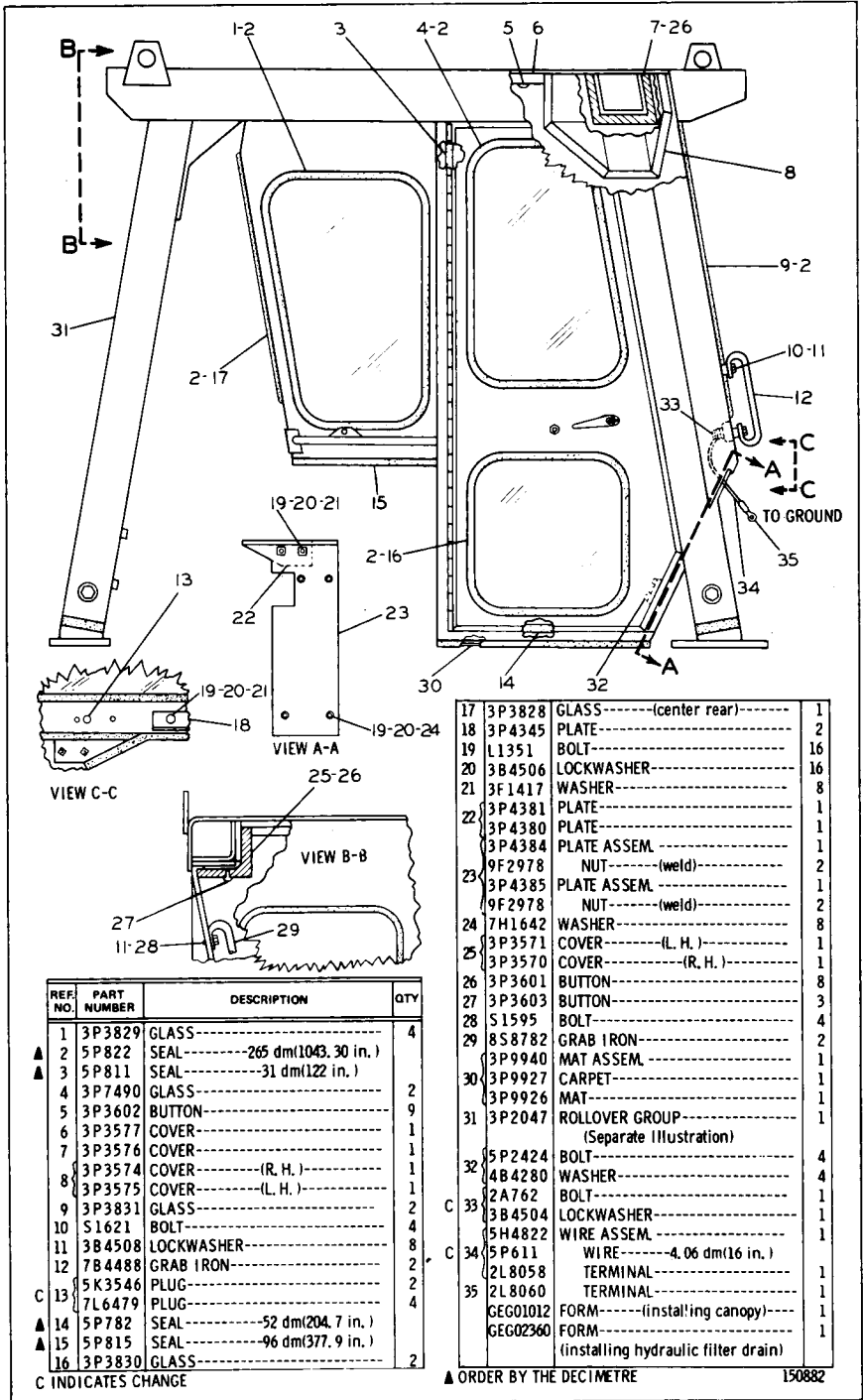

REF. NO.	PART NUMBER	DESCRIPTION	QTY
1	3P3829	GLASS	4
▲ 2	5P822	SEAL-----265 dm(1043.30 in.)	1
▲ 3	5P811	SEAL-----31 dm(122 in.)	1
4	3P7490	GLASS	2
5	3P3602	BUTTON	9
6	3P3577	COVER	1
7	3P3576	COVER	1
8	3P3574	COVER----- (R. H.)	1
8	3P3575	COVER----- (L. H.)	1
9	3P3831	GLASS	2
10	S1621	BOLT	4
11	3B4508	LOCKWASHER	8
12	7B4488	GRAB IRON	2
13	5K3546	PLUG	2
13	7L6479	PLUG	4
▲ 14	5P782	SEAL-----52 dm(204.7 in.)	1
▲ 15	5P815	SEAL-----96 dm(377.9 in.)	1
▲ 16	3P3830	GLASS	2

17	3P3828	GLASS----- (center rear)	1
18	3P4345	PLATE	2
19	L1351	BOLT	16
20	3B4506	LOCKWASHER	16
21	3F1417	WASHER	8
22	3P4381	PLATE	1
	3P4380	PLATE	1
	3P4384	PLATE ASSEM.	1
	9F2978	NUT----- (weld)	2
23	3P4385	PLATE ASSEM.	1
	9F2978	NUT----- (weld)	2
24	7H1642	WASHER	8
	3P3571	COVER----- (L. H.)	1
25	3P3570	COVER----- (R. H.)	1
	3P3601	BUTTON	8
26	3P3603	BUTTON	3
28	S1595	BOLT	4
29	8S8782	GRAB IRON	2
	3P9940	MAT ASSEM.	1
30	3P9927	CARPET	1
	3P9926	MAT	1
31	3P2047	ROLLOVER GROUP (Separate Illustration)	1
	5P2424	BOLT	4
32	4B4280	WASHER	4
	2A762	BOLT	1
C 33	3B4504	LOCKWASHER	1
	5H4822	WIRE ASSEM.	1
C 34	5P611	WIRE-----4.06 dm(16 in.)	1
	2L8058	TERMINAL	1
	2L8060	TERMINAL	1
	GEG01012	FORM----- (installing canopy)	1
	GEG02360	FORM (installing hydraulic filter drain)	1

C INDICATES CHANGE

▲ ORDER BY THE DECIMETRE

150882

3P9933 ROLL-OVER PROTECTIVE SYSTEM—Type 2  
 Part of 3P5982 Roll-Over Protective System listed on Page 248A. 3P2047  
 Roll-Over Protective Structure parts are shown on Page 250. AN ATTACHMENT

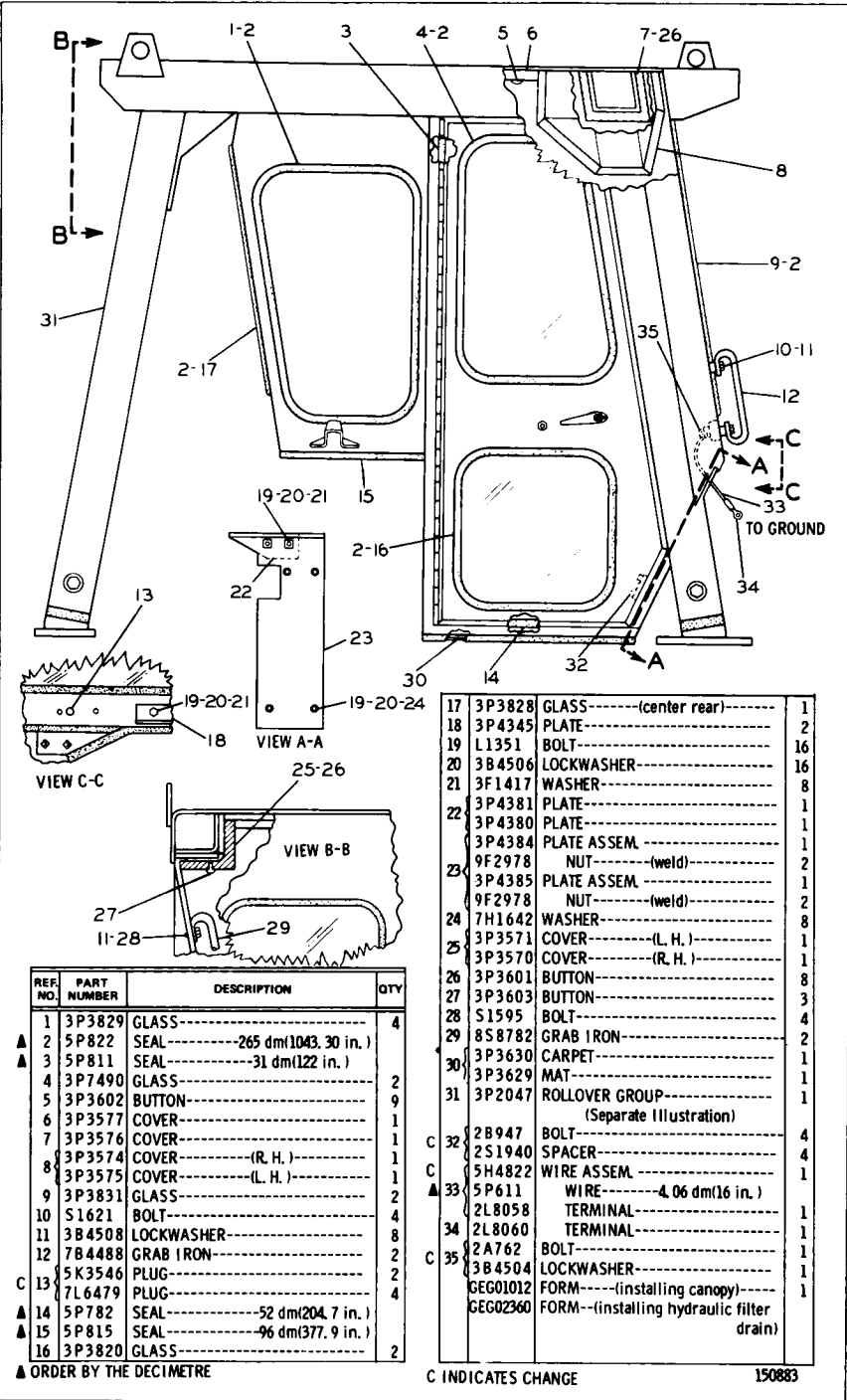

17	3P3828	GLASS-----	(center rear)	1
18	3P4345	PLATE-----		2
19	L1351	BOLT-----		16
20	3B4506	LOCKWASHER-----		16
21	3F1417	WASHER-----		8
22	3P4381	PLATE-----		1
22	3P4380	PLATE-----		1
22	3P4384	PLATE ASSEM.		1
23	9F2978	NUT-----	(weld)	2
23	3P4385	PLATE ASSEM.		1
23	9F2978	NUT-----	(weld)	2
24	7H1642	WASHER-----		8
25	3P3571	COVER-----	(L. H.)	1
25	3P3570	COVER-----	(R. H.)	1
26	3P3601	BUTTON-----		8
27	3P3603	BUTTON-----		3
28	S1595	BOLT-----		4
29	8S8782	GRAB IRON-----		2
30	3P3630	CARPET-----		1
30	3P3629	MAT-----		1
31	3P2047	ROLLOVER GROUP-----	(Separate Illustration)	1
C 32	2B947	BOLT-----		4
C 32	2S1940	SPACER-----		4
C 33	5H4822	WIRE ASSEM.		1
▲ 33	5P611	WIRE-----	4.06 dm(16 in.)	1
34	2L8058	TERMINAL-----		1
34	2L8060	TERMINAL-----		1
C 35	2A762	BOLT-----		1
C 35	3B4504	LOCKWASHER-----		1
C 35	GEG01012	FORM-----	(installing canopy)	1
C 35	GEG02360	FORM-----	(installing hydraulic filter drain)	1

REF. NO.	PART NUMBER	DESCRIPTION	QTY
▲ 1	3P3829	GLASS-----	4
2	5P822	SEAL-----	265 dm(1043.30 in.)
▲ 3	5P811	SEAL-----	31 dm(122 in.)
4	3P7490	GLASS-----	2
5	3P3602	BUTTON-----	9
6	3P3577	COVER-----	1
7	3P3576	COVER-----	1
8	3P3574	COVER-----	(R. H.)
8	3P3575	COVER-----	(L. H.)
9	3P3831	GLASS-----	2
10	S1621	BOLT-----	4
11	3B4508	LOCKWASHER-----	8
12	7B4488	GRAB IRON-----	2
C 13	5K3546	PLUG-----	2
C 13	7L6479	PLUG-----	4
▲ 14	5P782	SEAL-----	52 dm(204.7 in.)
▲ 15	5P815	SEAL-----	96 dm(377.9 in.)
16	3P3820	GLASS-----	2

▲ ORDER BY THE DECIMETRE

C INDICATES CHANGE

150883

3P3195 ROLL-OVER PROTECTIVE STRUCTURE GROUP—Enclosed—Type 2 FOR USE WITH 2P8538 AND 2P8965 MOUNTING GROUPS. 3P2047 Roll-Over Protective Structure parts are shown on Page 250. AN ATTACHMENT

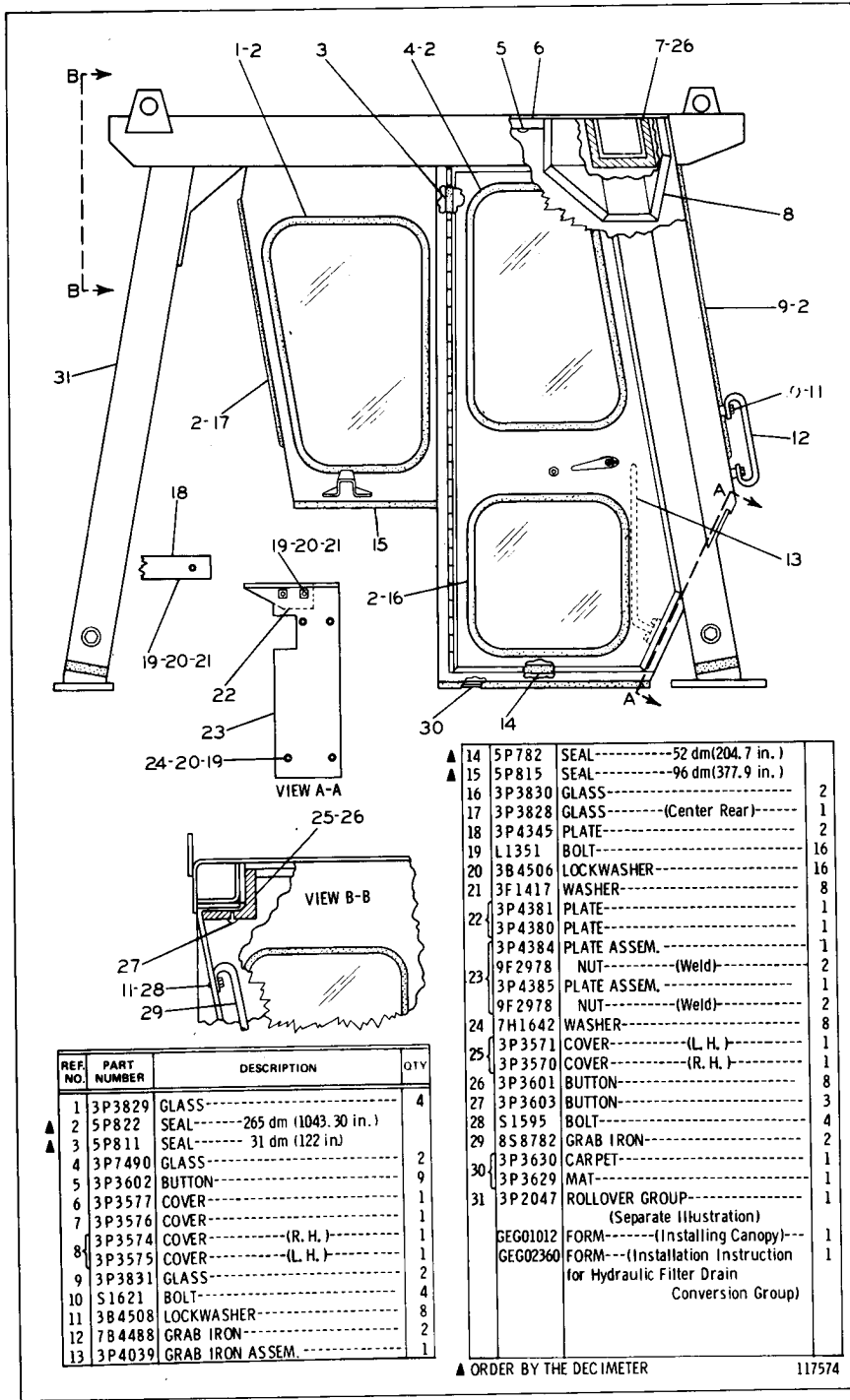

REF. NO.	PART NUMBER	DESCRIPTION	QTY
▲ 1	3P3829	GLASS	4
2	5P822	SEAL-----265 dm (1043.30 in.)	
3	5P811	SEAL-----31 dm (122 in)	
4	3P7490	GLASS	2
5	3P3602	BUTTON-----	9
6	3P3577	COVER-----	1
7	3P3576	COVER-----	1
8	3P3574	COVER----- (R. H.)	1
	3P3575	COVER----- (L. H.)	1
9	3P3831	GLASS	2
10	S1621	BOLT-----	4
11	3B4508	LOCKWASHER-----	8
12	7B4488	GRAB IRON-----	2
13	3P4039	GRAB IRON ASSEM.-----	1

▲ 14	5P782	SEAL-----52 dm(204.7 in.)	
15	5P815	SEAL-----96 dm(377.9 in.)	
16	3P3830	GLASS	2
17	3P3828	GLASS----- (Center Rear)-----	1
18	3P4345	PLATE-----	2
19	L1351	BOLT-----	16
20	3B4506	LOCKWASHER-----	16
21	3F1417	WASHER-----	8
22	3P4381	PLATE-----	1
	3P4380	PLATE-----	1
	3P4384	PLATE ASSEM.-----	1
	9F2978	NUT----- (Weld)-----	2
23	3P4385	PLATE ASSEM.-----	1
	9F2978	NUT----- (Weld)-----	2
24	7H1642	WASHER-----	8
25	3P3571	COVER----- (L. H.)	1
	3P3570	COVER----- (R. H.)	1
26	3P3601	BUTTON-----	8
27	3P3603	BUTTON-----	3
28	S1595	BOLT-----	4
29	8S8782	GRAB IRON-----	2
	3P3630	CARPET-----	1
30	3P3629	MAT-----	1
31	3P2047	ROLLOVER GROUP----- (Separate Illustration)	1
	GEG01012	FORM----- (Installing Canopy)---	1
	GEG02360	FORM----- (Installation Instruction for Hydraulic Filter Drain Conversion Group)	1

▲ ORDER BY THE DECIMETER

117574

3P3195 ROLL-OVER PROTECTIVE STRUCTURE GROUP—Enclosed  
3P2047 Roll-Over Protective Structure parts are shown on Page 250  
AN ATTACHMENT

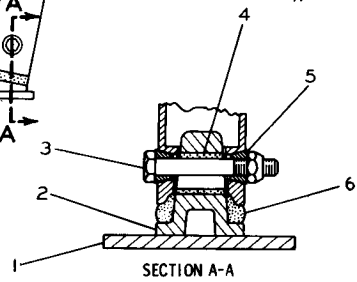
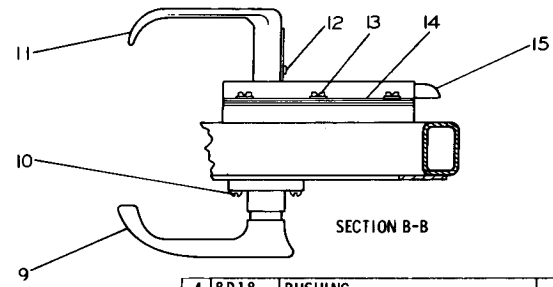
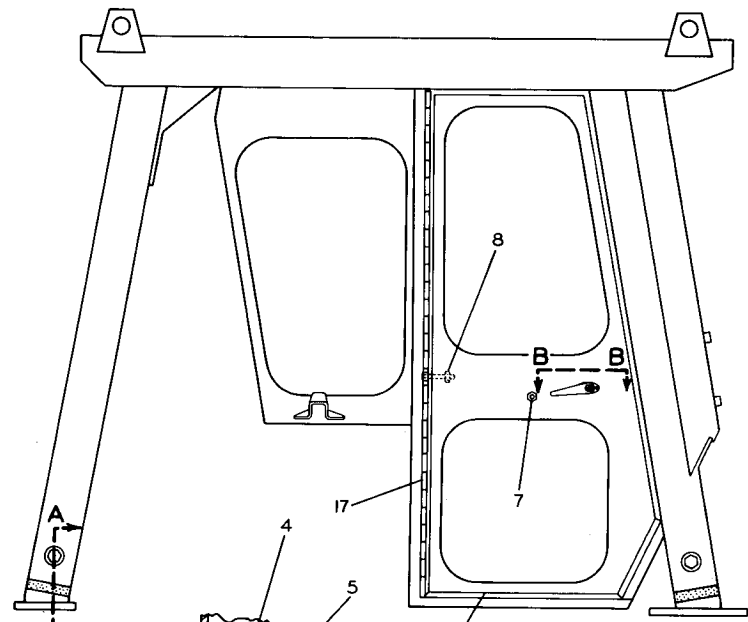

REF. NO.	PART NUMBER	DESCRIPTION	QTY
1	3P5946	PLATE-----	2
2	3P3482	BAYONET-----	4
3	5F9338	BOLT-----	4
	6K3632	LOCKNUT-----	2

4	8D18	BUSHING-----	4
5	8D9054	WEDGE-----	8
6	8D6544	PAD-----	4
7	3H3680	NUT-----	2
	8D6371	KNOB-----	2
C 8	1B2713	BOLT-----	20
	7H8909	NUT-----	20
C 8	4B4276	WASHER--.0625 in. (1.57 mm) thick	20
C 8	8M2337	WASHER--.125 in. (3.18 mm) thick	20
9	3P4539	HANDLE-----	2
10	3P4571	SCREW-----	4
11	3P4542	HANDLE-----	2
C 12	6P4001	SETSCREW----- (locking)-----	2
	6P4002	SETSCREW-----	2
13	1H2204	SCREW-----	12
14	3P6960	SHIM-----	4
15	3P4540	LATCH-----	2
C 16	6P4035	DOOR ASSEM.----- (R. H.)-----	1
	6P4034	DOOR ASSEM.----- (L. H.)-----	1
C 17	6P4033	HINGE-----	2
▲	3P6597	KEY----- (door)-----	2
▲	5P1410	FILM----- (ROPS)-----	1

C INDICATES CHANGE ▲ NOT SHOWN 150813

3P2047 ROLL-OVER PROTECTIVE STRUCTURE GROUP—Bolt-On  
 Part of 3P9933 and 3P3195 Roll-Over Protective Structure Groups shown on Pages 248E through 249

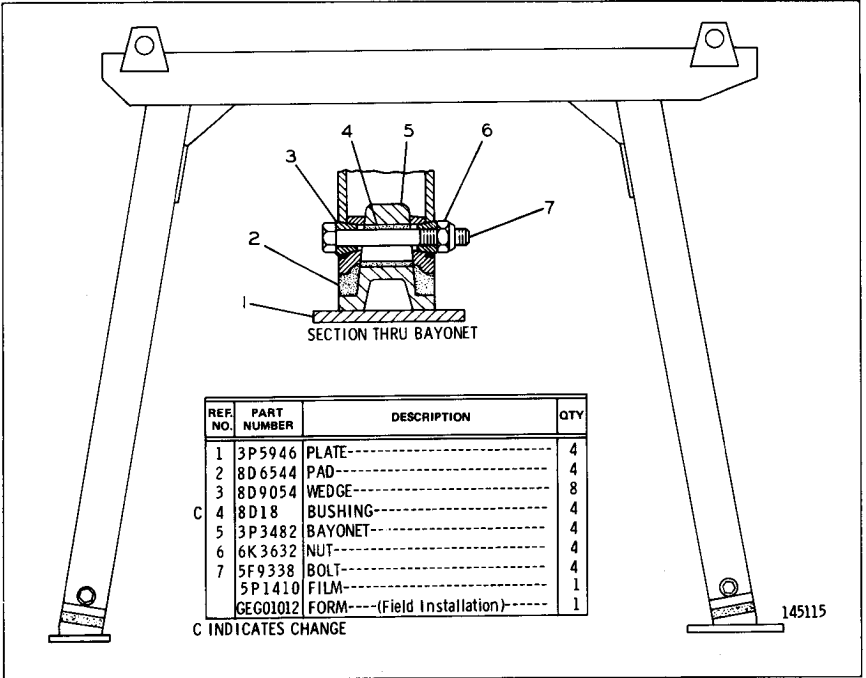

3P2015 ROLL-OVER PROTECTIVE STRUCTURE GROUP—Open AN ATTACHMENT

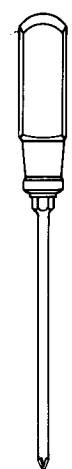

951738 SCREWDRIVER  
NO. 2 PHILLIPS

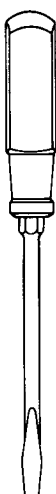

JF1157 SCREWDRIVER

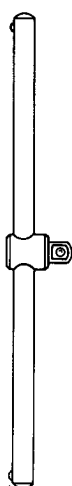

559566 WRENCH



559567 EXTENSION

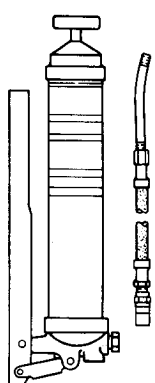

8F9866 GREASE GUN (Lever)  
(See Separate Illustration)

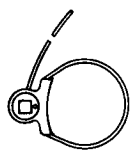

2P8250 STRAP WRENCH ASSEM.



559569 SOCKET



559568 SOCKET



C 5P1763 SOCKET

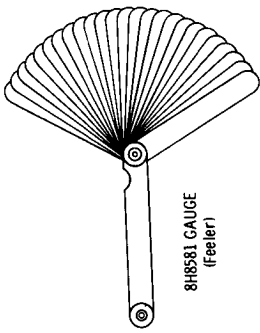

8H8581 GAUGE  
(feeler)

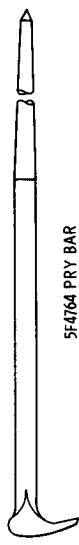

5F4764 PRY BAR



- 8H8503 WRENCH (5/16" Opening)
- 8H8505 WRENCH (3/8" Opening)
- 8H8513 WRENCH (7/8" Opening)
- 8H8508 WRENCH (9/16" Opening)
- 8H8509 WRENCH (5/8" Opening)
- 8H8511 WRENCH (3/4" Opening)
- 8H8515 WRENCH (1" Opening)



- 8H8549 SOCKET (9/16" Opening)
- 8H8554 SOCKET (7/8" Opening)
- 8H8555 SOCKET (5/16" Opening)
- 8H8556 SOCKET (1" Opening)
- 9S1730 SOCKET (11/8" Opening)

C INDICATES CHANGE

201200

9S7977 HAND TOOL GROUP  
AN ATTACHMENT



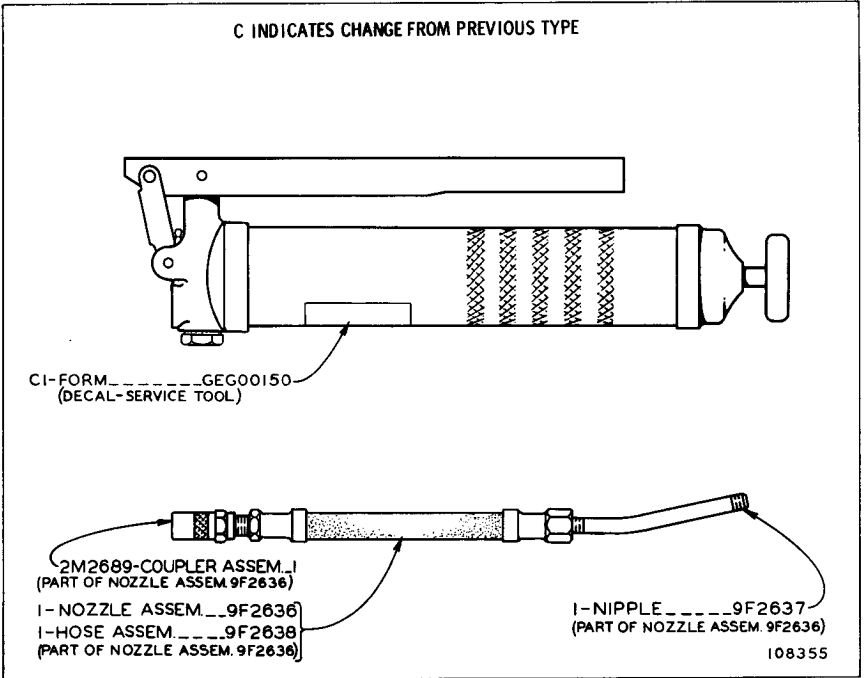

**8F9866 GREASE GUN**  
Part of 9S7977 Hand Tool Group  
AN ATTACHMENT

- 5P1915 DIESEL ENGINE BASIC
- 5P1966 DIESEL ENGINE SUPPLEMENTARY
- 5P2100 VALVE GRINDING
- 5P1937 WATER PUMP

## CATERPILLAR 977L TRAXCAVATOR

QUANTITY USED	PART NUMBER	DESCRIPTION
1	3H3842	PLATE--SERIAL NUMBER (LOADER) ON BEVEL GEAR AND STEERING CLUTCH CASE
1	6H4356	PLATE--WARNING BELOW SERIAL NUMBER PLATE ON LOWER DASH
2	1P289	PLATE--WARNING ON LOADER FRAME BELOW LIFT ARM PIVOT ON EACH SIDE OF MACHINE
1	5P215	PLATE--SERIAL NUMBER (MASTER) IN OPERATOR'S COMPARTMENT NEAR TOP OF HYDRAULIC CONTROL GUARD ASSEMBLY
16	4B4158	DRIVE SCREW
1	1P2809	FILM--SYMBOL (LIGHT) ON TOP OF LIGHT SWITCH KNOB
1	1P7796	FILM--SYMBOL (PARK) AT L.H. SIDE OF HYDRAULIC CONTROL CONSOLE
1	2P2179	FILM--LUBRICATION INSTRUCTIONS ON TOP OF BATTERY BOX COVER ON L.H. SIDE
1	5S3906	FILM--STEERING INSTRUCTIONS ON LOWER DASH
1	5S7667	FILM--FILTER DRAIN INSTRUCTIONS ABOVE FILTER DRAIN PLUG ON SIDE OF HYDRAULIC TANK
1	7S3178	FILM--AIR CLEANER INSTRUCTIONS ON DIESEL AIR CLEANER COVER
1	8S3703	FILM--STARTING INSTRUCTIONS BELOW GAUGES ON DASH
1	2P4161	TRANSFER GROUP CONSISTING OF:
1	.....	TRANSFER--CATERPILLAR ON RADIATOR GUARD
1	.....	TRANSFER--HYDRAULIC SYSTEM
1	.....	FILM--CAPACITY ON TOP OF FUEL TANK NEAR FILLER NECK
2	.....	FILM--CORPORATE SYMBOL ON R.H. SIDE OF HYDRAULIC TANK AND ON L.H. SIDE OF SEAT
1	8S4198	TRANSFER--FILTER INSTRUCTIONS ON FUEL FILTER
1	8S5495	TRANSFER--CATERPILLAR ON BACK OF FUEL TANK
1	5S3904	FILM--CAUTION ON L.H. SIDE OF LOWER DASH
1	5S3910	FILM--SAFETY ON R.H. SIDE OF LOWER DASH
2	2P4155	FILM--977L ON R.H. SIDE OF HYDRAULIC TANK AND ON L.H. SIDE OF SEAT

NAME PLATES AND TRANSFERS

QUANTITY USED	PART NUMBER	DESCRIPTION
1	6H4356	PLATE--WARNING ON LOWER DASH
1	1K7846	PLATE--WARNING ON R.H. SIDE OF HYDRAULIC TANK
1	1K7847	PLATE--WARNING ON SIDE OF HYDRAULIC TANK BELOW FILLER SPOUT
2	2P289	PLATE--WARNING ON LOADER FRAME BELOW LIFT ARM PIVOT ON EACH SIDE OF MACHINE
1	1P9104	PLATE--HYDRAULIC SYSTEM FILTER ON HYDRAULIC TANK BELOW FILTER COVER
1	8S7773	PLATE--LUBRICATION ON L.H. SEAT SUPPORT PLATE ASSEMBLY TO REAR OF FILTER
18	4B4158	DRIVE SCREW
1	1P3452	TRANSFER--FUEL FILTER ON FUEL FILTER
1	8S5494	TRANSFER--CATERPILLAR ON BACK OF FUEL TANK
1	1P2809	FILM--SYMBOL (LIGHT) ON TOP OF LIGHT SWITCH KNOB
1	1P7796	FILM--SYMBOL (PARK) IN FULL VIEW OF OPERATOR AT L.H. SIDE OF HYDRAULIC CONTROL CONSOLE
1	2P4155	FILM--977L ON R.H. SIDE OF HYDRAULIC TANK
1	5S3904	FILM--CAUTION ON L.H. SIDE OF LOWER DASH
1	5S3906	FILM--STEERING ON LOWER DASH
1	5S3910	FILM--SAFETY ON DASH
1	5S7667	FILM--FILTER DRAIN INSTRUCTIONS ABOVE FILTER DRAIN PLUG ON SIDE OF HYDRAULIC TANK
1	7S3178	FILM--AIR CLEANER ON DIESEL AIR CLEANER COVER
1	8S3703	FILM--STARTING ON LOWER DASH

NAME PLATES AND TRANSFERS  
FOR USE WITH FIRE RESISTANT HYDRAULIC ARRANGEMENT  
AN ATTACHMENT

# CATERPILLAR 977L TRAXCAVATOR

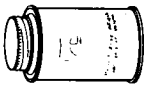

GASKET CEMENT  
3H2471 8 oz. (227 g)

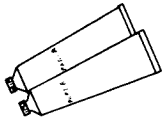

EPOXY CEMENT  
5M2941 2 - 2 oz. (57g) Tube

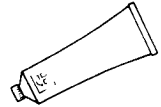

BEARING LUBRICANT  
253230 14 1/2 oz. (411 g)

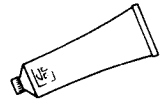

GASKET SEALER  
4H5363 11 oz. (312 g)  
(fast drying-hard setting)  
8H5137 11 oz. (312 g)  
(non-hardening)

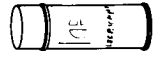

ANTI-SEIZURE COMPOUND  
4S9416 16 oz. (454 g) Aerosol  
9M3710 16 oz. (454 g) Paste

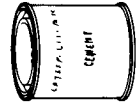

GLASS OR PLASTIC CEMENT  
3S1831 1 pint (0.473 L)

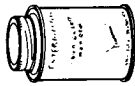

LIQUID GASKET  
7M7260 8 oz. (227 g)



SEALING COMPOUND  
5S1454 1 pint (0.473 L)



GREASE - SILICONE  
4L7464 8 oz. (227 g)

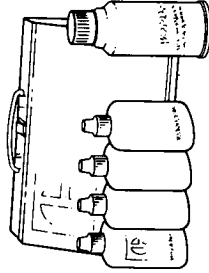

953262 SEALANT REPAIR KIT

contains:

- Bearing Mount 7M7456 1 2/3 fl. oz. (50 cc)
- Thread Lock 9S3263 1 2/3 fl. oz. (50 cc)
- Pipe Sealant 9S3264 1 2/3 fl. oz. (50 cc)
- Retaining Compound 9S3265 1 2/3 fl. oz. (50 cc)
- Quick Cure Primer 8M8060 6 oz. (170 g) Aerosol

CHAIN & CABLE LUBRICANT

- 9S6106 16 oz. (454 g) Aerosol
- 2P2737 Case of 12

BELT DRESSING

- 9S6107 16 oz. (454 g) Aerosol
- 2P2738 Case of 12

ELECTRO-INSULATION SPRAY

- 9S6108 16 oz. (454 g) Aerosol
- 2P2739 Case of 12

PENETRATING OIL

- 9S6109 16 oz. (454 g) Aerosol
- 2P2740 Case of 12

BATTERY SAVER & CLEANER

- 9S6110 16 oz. (454 g) Aerosol
- 2P2741 Case of 12

139339

RELATED REPAIR ITEMS

RELATED REPAIR ITEMS

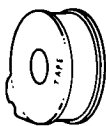

ELECTRICAL TAPE

1P810 (plastic) 2 1/2" (20mm) width  
66 ft. (20m) length  
984287 (cloth) 3/4" (20mm) width  
30 ft. (9M) length  
(Plastic tape comes in dispenser.  
Cloth tape does not.)



9S8703 ANTI-SKID TREADS

(May be ordered by foot lengths up to  
60 feet (18, 30m), width 4" (100mm)



8S4627 CIRCUIT TESTER

(Maximum Capacity: 10 oms)



MAGNETIC DRAIN PLUGS

Hole		Part Number	Type	Thread Size-Threads Per Inch	Head Inches	A		Part No.
Diameter Inches	mm					Inches	mm	
.219	5.6	4L0820	I	5/8 - 11	7/8 Hex	1 3/16	26.9	5K1555
.310	7.9	7L6479	I	5/8 - 18	7/8 Hex	3/4	19.1	2R1666
.380	9.7	5L6688	I	7/8 - 14	1 1/8 Hex	1 3/16	30.2	3H4190
.438	11.1	4L0821	I	1 1/8 - 12	1 1/2 Hex	1 1/2	38.1	8M3837
.469	11.9	3D9871	I	1 1/8 - 12	1 1/2 Hex	1 7/8	47.8	2J1559
.484	12.3	8M3839	I	1 1/2 - 12	1 Hex	1 1/2	38.1	8M5576
.500	12.7	3D9872	I	1 1/2 - 12	1 7/8 Hex	1 7/8	47.8	2D8390
.625	15.9	2M4009	II	1/2 - 14	9/16 Sq.	1 1/8	28.5	2F3628
.687	17.5	6K2660	II	3/4	5/8 Sq.	1 1/4	31.8	2H3865
.750	19.0	5K3546	II	7/8 - 14	7/8 Hex	1 5/8	41.3	2R1491
.875	22.2	5H4871	II	1 Std. Pipe Thd.	13/16 Sq.	1 7/16	36.6	2H3964
1.000	25.4	2D3406	II	1 1/4 Std. Pipe Thd.	15/16 Sq.	1 11/16	42.9	2H3863
1.250	31.8	4S6336	II	1 1/4 Std. Pipe Thd.	15/16 Sq.	1 3/8	35.0	7H3664
1.375	34.9	4F8711	II	3/4 - 14 Pipe Thd., Fine	1/2 Sq.	1 3/16	30.2	5D1894
1.500	38.1	3L1979	III	1 - 11 1/2 Pipe Thd., Fine	1/2 Sq.	1 5/16	33.4	2K744
2.000	50.8	1L6377	III	1 1/4 - 11 1/2 Pipe Thd., Fine	3/4 Sq.	13/16	20.6	5S4017
2.250	57.2	7M3248	III	2 - 12	3/4 Sq.	1 11/16	42.9	8B6599
2.500	63.5	3L8852	III					
3.000	76.2	1L6366	III					



BUTTON PLUGS

# SPECIFICATIONS

(SUBJECT TO CHANGE WITHOUT NOTICE)

Weight, shipping (approximate) (with ROPS Mounting)	
977 Traxcavator .....	42,300 lb.

## DIMENSIONS

Length .....	18' 5"
Width, without bucket .....	7' 10"
Height .....	10'
Bucket Width .....	98"
Dumping Clearance .....	10' 6"
Dumping Height .....	13' 2"
Dumping Reach .....	4' 2"
Maximum Digging Depth .....	4 $\frac{3}{4}$ "

## CAPACITIES

Cooling System .....	13 U.S. Gal.
Lubricating System:	
Crankcase .....	7 $\frac{1}{4}$ U.S. Gal.
Transmission, Bevel Gear & Steering Clutch Case ..	24 $\frac{1}{2}$ U.S. Gal.
Final Drives (each side) .....	6 $\frac{3}{4}$ U.S. Gal.
Fuel Tank .....	102 U.S. Gal.
Hydraulic System .....	36 $\frac{1}{2}$ U.S. Gal.
Bucket .....	2 $\frac{3}{4}$ Cu. Yd.

## MACHINE SERIAL NUMBER PLATE LOCATION

Traxcavator serial number plates are located on the bevel gear and steering clutch case, and in operator's compartment on right-hand side of firewall.

# CARACTÉRISTIQUES

(PEUVENT ÊTRE MODIFIÉES SANS PRÉAVIS)

Poids (approx.), en ordre d'expédition (avec groupe de pose pour bâti de sécurité)

Traxcavator 977 ..... 19 200 kg

## DIMENSIONS

Longueur .....	5 610 mm
Largeur, sans godet .....	2 390 mm
Hauteur .....	3 050 mm
Largeur du godet .....	2 490 mm
Hauteur maximale de vidage .....	3 200 mm
Hauteur de déversement .....	3 960 mm
Distance de déversement .....	1 270 mm
Profondeur maximale de cavage .....	120 mm

## CONTENANCES

Circuit de refroidissement .....	49 litres
Circuits de graissage:	
Carter moteur .....	27 litres
Transmission, carter du couple conique et de l'embrayage de direction .....	93 litres
Réducteurs latéraux (chaque) .....	26 litres
Réservoir de carburant .....	386 litres
Circuit hydraulique .....	138 litres
Godet .....	2,1 m <sup>3</sup>

## MARQUAGE DU NUMÉRO DE SÉRIE

Les plaques portant les numéros de série sont situées sur le carter du couple conique et de l'embrayage de direction et sur le côté droit du cloison pare-feu du poste de conduite.

# ESPECIFICACIONES

(SUJETAS A CAMBIO SIN PREVIO AVISO)

Peso de embarque aproximado del Traxcavator 977  
con montaje para estructura protectora contra vuelcos .. 19200 kg

## DIMENSIONES

Longitud .....	5610 mm
Ancho, sin cucharón .....	2390 mm
Alto .....	3050 mm
Ancho del cucharón .....	2490 mm
Despeje de descarga .....	3200 mm
Altura de descarga .....	3960 mm
Alcance de descarga .....	1270 mm
Profundidad máxima de excavación .....	120 mm

## CAPACIDADES

Sistema de enfriamiento .....	49 litros
Sistema de lubricación:	
Cárter .....	27 litros
Caja de la transmisión, corona y embragues de dirección	93 litros
Mandos finales (cada uno) .....	26 litros
Tanque del combustible .....	386 litros
Sistema hidráulico .....	138 litros
Cucharón .....	2,1 m <sup>3</sup>

## UBICACION DE LA PLACA CON EL NUMERO DE SERIE DE LA MAQUINA

Las placas con número de serie del Traxcavator están colocadas en la caja de la corona y embragues de dirección, en el compartimiento del operador, en el lado derecho del tablero en el lado de la plancha separadora del motor.



# ESPECIFICAÇÕES

(SUJEITAS A ALTERAÇÕES SEM AVISO PRÉVIO)

Peso de embarque, com estrutura de segurança ..... 19 200 kg

## DIMENSÕES E CAPACIDADE

Comprimento .....	5 610 mm
Largura (sem caçamba) .....	2 390 mm
Altura .....	3 050 mm
Largura da caçamba .....	2 490 mm
Altura livre para despejo .....	3 200 mm
Elevação máxima .....	3 960 mm
Alcance horizontal .....	1 270 mm
Profundidade máxima de escavação .....	120 mm
Capacidade da caçamba .....	2,1 m <sup>3</sup>

## QUANTIDADES CONTIDAS

Sistema de arrefecimento .....	49 litros
Sistemas de lubrificação:	
Cárter do motor .....	27 litros
Caixa de mudanças, da coroa e das embreagens de direção .....	93 litros
Comandos finais (cada) .....	26 litros
Tanque de combustível .....	386 litros
Sistema hidráulico .....	138 litros

## SITUAÇÃO DO NÚMERO DE SÉRIE

Existem placas com o número de série atrás da caixa da coroa e na parte inferior direita do painel dianteiro da plataforma de operação.

# TECHNISCHE DATEN

(UNVERBINDLICH, ÄNDERUNGEN VORBEHALTEN)

Versandgewicht, etwa

977L Traxcavator (mit Überroll-Schutzdachauflager) . . . . . 19 200 kg

## ABMESSUNGEN

Länge	5 610 mm
Breite (ohne Schaufel)	2 390 mm
Höhe	3 050 mm
Schaufelbreite	2 490 mm
Schütthöhe	3 200 mm
Abkipphöhe	3 960 mm
Reichweite	1 270 mm
Max. Grabtiefe	120 mm

## FÜLLMENGEN

Kühlsystem	49 l
Schmiersystem:	
Kurbelgehäuse	27 l
Getriebe, Tellerrad- und Lenkkupplungsgehäuse	93 l
Seitenantriebe, je	26 l
Kraftstofftank	386 l
Hydraulikanlage	138 l
Schaufel	2,1 m <sup>3</sup>

## LAGE DER SERIENNUMMERNESCHILDER

Seriennummernschilder befinden sich am Tellerrad- und Lenkkupplungsgehäuse und rechts an der Feuerwand im Fahrerstand.

CONVERSION EQUIVALENT TABLES  
VOLUME AND CAPACITY EQUIVALENTS

Unit	Cu. In.	Cu. Ft.	Cu. Yd.	Cu. Cm.	Cu. M.	U.S. Liquid Gallons	Imperial Gallons	Liters
1 Cu. In.	1	.000579	.0000214	16.39	.0000164	.004329	.00359	.0164
1 Cu. Ft.	1728	1	.3704	28317	.283	7.481	6.23	28.32
1 Cu. Yd.	46656	27	1	764600	.765	202	167.9	764.6
1 Cu. Cm.	.691	.0000353	.0000031	1	.000001	.000264	.00022	.001
1 Cu. M.	61020	35.31	1.308	1,000,000	1	264.2	220.2	1000
1 U.S. Liquid Gal.	231	.1337	.00495	3785	.00785	1	.833	3.785
1 Imperial Gallon	277.42	.16	.00594	4545.6	.004546	1.2	1	4.546
1 Liter	61.02	.0351	.001308	1000	.001	.2842	.22	1

LENGTH EQUIVALENTS

Unit	Centimeters	Inches	Feet	Yards	Meters	Kilometers
1 Centimeter	1	0.3937	0.03281	0.01094	0.01	
1 Inch	2.540	1	0.08333	0.02778	0.0254	
1 Foot	30.48	12	1	0.3333	0.3048	
1 Yard	91.44	36	3	1	0.9144	
1 Meter	100	39.37	3.281	1.0936	1	
1 Kilometer	100000	39370	3281	1093.6	1000	1

AREA EQUIVALENTS

Unit	Sq. Cm.	Sq. In.	Sq. M.	Sq. Ft.
1 Sq. Cm.	1	0.156		
1 Sq. In.	6.4516	1		
1 Sq. M.	10,000	1550	1	10.764
1 Sq. Ft.	929	144	0.0929	1

WEIGHT EQUIVALENTS

Unit	Kilograms	Ounces	Pounds
1 Kilogram	1	35.27	2.205
1 Ounce	0.02835	1	0.0625
1 Pound	0.4536	16	1

Inches to Centimeters and Centimeters to Inches

Inches or Centimeters	Inches	Centimeters
1	2.54	25.4
2	5.08	50.8
3	7.62	76.2
4	10.16	101.6
5	12.70	127.0
6	15.24	152.4
7	17.78	177.8
8	20.32	203.2
9	22.86	228.6
10	25.40	254.0
11	27.94	279.4
12	30.48	304.8
13	33.02	330.2
14	35.56	355.6
15	38.10	381.0
16	40.64	406.4
17	43.18	431.8
18	45.72	457.2
19	48.26	482.6
20	50.80	508.0
21	53.34	533.4
22	55.88	558.8
23	58.42	584.2
24	60.96	609.6
25	63.50	635.0

How to use:

11 inches = 27.94 centimeters  
11 centimeters = 4.33 inches

Inches or Centimeters	Inches	Centimeters
1	2.54	25.4
2	5.08	50.8
3	7.62	76.2
4	10.16	101.6
5	12.70	127.0
6	15.24	152.4
7	17.78	177.8
8	20.32	203.2
9	22.86	228.6
10	25.40	254.0
11	27.94	279.4
12	30.48	304.8
13	33.02	330.2
14	35.56	355.6
15	38.10	381.0
16	40.64	406.4
17	43.18	431.8
18	45.72	457.2
19	48.26	482.6
20	50.80	508.0
21	53.34	533.4
22	55.88	558.8
23	58.42	584.2
24	60.96	609.6
25	63.50	635.0



**CATERPILLAR**

Caterpillar, Cat and  are Trademarks of Caterpillar Tractor Co.