

Austin-Western

**NO. 99H
POWER GRADER
(WITH ATTACHMENTS)**

pa

INDEX

DESCRIPTION	ILLUSTRATION	PAGE
Air Cleaner - UD-14A Engine.....	44,45	66
Blade.....	13,13A	22,22A
Blade Extensions and Cutting Edges.....	14,14A	23,23A
Blade Lift Ram.....	8	14
Blade Side Shift Ram.....	9,9A	15,15A
Brake Master Cylinder.....	25	40
Bulldozer.....	53,55	76 to 79
Circle.....	11,11A	18 to 19B
Circle Latch Cylinder.....	12	20,21
Circle Latch Master Cylinder.....	12	20,21
Circle Latch Mechanism.....	12	20,21
Circle Reverse Hydraulic Motor.....	10	16,17
Clutch - UD-14A Engine.....	29,29A	44 to 45B
Clutch and Shaft Assembly - UD-14A Engine.....	27	42
Clutch Brake.....	22	35
Clutch Operating Mechanism.....	28	43
Conveyor Loader.....		80 to 101
- Bevel Gear Drive.....	61	88,89
- Carrying Roller - Intermediate.....	67	94
- Carrying Roller - Lower.....	68	94
- Carrying Roller - Upper.....	66	93
- Countershaft.....	72	96
- Feeder Shaft.....	64	91
- General Parts.....	57	80,81,82
- Head Drum and Belt.....	65	92
- Hydraulic Control Valve.....	75	100
- Hydraulic Hose Chart.....	76	101
- Hydraulic System - Piping Diagram.....	74	98,99
- Lift Ram.....	73	97
- Power Take-off.....	59	84,85
- Power Take-off Clutch.....	60	86,87
- Propeller Shafts.....	62,63	90
- Return Roller.....	69	95
- Snub Roller.....	71	96
- Tail Light and Horn Circuit.....	58	83
- Tail Pulley.....	70	95
Defroster Fan.....	50	72,73
Draw Bar.....	11,11A	18 to 19B
Engine and Accessories - UD-14A Engine.....	42	62 to 65
Foot Brake Mechanism.....	25	40
Front Axle Gear and Pinion Carrier.....	2	6,7
Front Axle Steering Knuckle and Universal Joint.....	3	8,9
Front Axle Steering Knuckle, Wheel and Tire.....	4	10
Front Axle Steering Ram.....	6	12
Front Axle Tie Rod and Axle Support.....	5	11
Front Propeller Shaft - Center Section.....	16	25
Front Propeller Shaft - Front Section.....	15	24
Front Propeller Shaft - Rear Section.....	17	26
Fuel System - UD-14A Engine.....	49	70,71
Gas Strainer - UD-14A Engine.....	43	65
Generators - UD-14A Engine.....	50	72,73
Hand Brake Mechanism.....	26	41
Headlights.....	51	74
Heater - UD-14A Engine.....	48	69
High Lift Ram.....	7,7A	13,13A
Highway Department Codes.....		3
Hourmeter - UD-14A Engine.....	46	67
Hydraulic Hose Chart.....	38A	58

 See Page 121 for Numerical Index of Parts

INDEX

DESCRIPTION	ILLUSTRATION	PAGE
Hydraulic Motor - Circle Reverse.....	10	16, 17
Hydraulic Piping Diagram - UD-14A Engine.....	38	56 to 57B
Hydraulic Pump and Pulley - UD-14A Engine.....	39	59
Hydraulic Valve Controls.....	41	61
Hydraulic Valve Mechanism.....	40	60
Instructions for Ordering Parts.....		2
Miscellaneous Parts.....	1	4, 5
Odometer.....	21	34
Propeller Shaft - Clutch to Transmission.....	18	27
Propeller Shaft Brake.....	24	38, 39
Propeller Shaft Brake Cylinder.....	24	38, 39
Radiator - UD-14A Engine.....	47	68
Radiator Shutter - UD-14A Engine.....	47	68
Rear Axle Gear and Pinion Carrier.....	30	46, 47
Rear Axle Steering Knuckle and Universal Joint -Left.....	31	48, 49
Rear Axle Steering Knuckle and Universal Joint -Right.....	32	50, 51
Rear Axle Steering Knuckle, Wheel and Tire -Left.....	33	52
Rear Axle Steering Knuckle, Wheel and Tire -Right.....	34	53
Rear Axle Steering Ram.....	36	54
Rear Axle Tie Rod.....	35	53
Rear Propeller Shaft.....	37	55
Return of Parts.....		2
Roller Attachment.....		101 to 106
- Hydraulic Control Valve.....	80	106
- Hydraulic Hose Chart.....	76	101
- Hydraulic System - Piping Diagram.....	79	104, 105
- Ram.....	78	103
- Roller.....	77	102
Scarifier.....	52	75
Scarifier Ram.....	54, 56	77, 79
Shipping Instruction Codes.....		3
Snow Plow.....		108 to 111
- Giant "V" Type.....	83	108, 109
- One-Way.....	84	110, 111
Snow Removal Lights.....	81	107
Snow Wing Attachment.....		112 to 119
- Hydraulic Control Valve.....	89	118
- Hydraulic System - Piping Diagram.....	86	114, 115
- Lift Ram - Front.....	88	117
- Lift Ram - Rear.....	87	116
- Snow Wing.....	85	112, 113
- Spot Light.....	90	119
Starting Motor - UD-14A Engine.....	50	72, 73
Swivel Junction Mechanism.....	38	56, 57B
Tire Pump.....	23	36, 37
Tools.....	91	120
Transfer Case.....	20	32, 33, 34
Transmission.....	19A, 19B	28 to 31
Voltage Regulator - UD-14A Engine.....	50	72, 73
Wipers - Windshield.....	50	72, 73, 74
Wiring Diagram - Snow Removal Lights.....	82	107
Wiring Diagram - UD-14A Engine.....	50	72, 73, 74

☞ See Page 121 for Numerical Index of Parts

INSTRUCTIONS FOR ORDERING PARTS

When ordering parts, follow the instructions listed below. By doing this you will be assured of receiving the correct part in the shortest period of time.

1. Send your order to the Austin-Western Company Distributor for your territory.
2. Give the machine serial number which will be found on the name plate attached to the machine.
3. Write the quantity, part number and description of the part wanted.
4. Give definite shipping instructions, that is: to whom and where the parts are to be shipped, also whether shipment is to go by parcel post, express, freight or truck, prepaid or collect.
5. Confirm all telephone or telegraph orders in writing.

RETURN OF PARTS

When you return parts to your Austin-Western Company Distributor, be sure the package or part is tagged with your name and address; prepay transportation charges; then write to the distributor giving full details of shipment as to when, how and why parts are being returned. Give the machine number for which parts are being returned.

CLAIMS FOR SHORTAGE OR BREAKAGE should be made to the transportation company on receipt of goods.

SHIPPING INSTRUCTION CODES

QSJPK Ship by freight
 PDFRT Ship by freight - prepaid
 AZIRP Ship by freight - C.O.D.
 QSKTP Ship by freight or express
 PDFEX Ship by freight or express - prepaid
 AZIPN Ship by freight or express - C.O.D.
 QSJOJ Ship by express
 PDEXP Ship by express - prepaid
 QSKMI Ship by express - C.O.D.
 AZISQ Ship by air express
 NTSIK Ship by parcel post
 AZIQO Ship by parcel post - C.O.D.
 AZITR Ship by parcel post - special delivery
 QUNIV Ship by consolidated car
 WUNIV Was shipped by consolidated car
 QSROR Ship to our (my) order and notify
 QKRYK Ship what is ready - balance soon as possible
 QWSHP Will ship
 QUNAB Unable to ship
 QRZAM How did you ship
 QSADP How soon can you ship
 QSSZD Telegraph if you can ship at once
 QSUZF When do you expect to ship order (s)
 QSYSC Will ship balance of goods as soon as possible
 QSYEO Will prepare to ship and hold until instructions are received
 QUGYO Shipment (s) must be made (by)
 QUKCW Shipment (s) were (was) made on _____
 QUIME Shipment of has not arrived
 QUCZL Shipment (s) are (is) being held up on account of shortage of some
 requisite material which is expected on _____ estimate shipment can
 be made on or about _____
 PLCPJ Have received no reply from to our (my) letter of
 PLPKD Have received no reply from to our (my) telegram of
 DEBHV Cancel our (my) order for sent in our (my) _____ letter (of)
 DEBIW Cancel our (my) order for sent in our (my) _____ telegram (of)
 PBSWP Refer to our (my) communication of for
 AIRMA Air mail - special delivery

CODES FOR ALL HIGHWAY DEPARTMENTS

Alabama	ALSHD	Maine	MESH	Ohio	OHSHD
Arizona	AZSHD	Maryland	MDSHD	Oklahoma	OKSHD
Arkansas	AKSHD	Massachusetts	MASHD	Oregon	ORSHD
California	CALHD	Michigan	MCSHD	Pennsylvania	PASHD
Colorado	COLHD	Minnesota	MNSHD	Rhode Island	RISHD
Connecticut	CONHD	Mississippi	MSHD	So. Carolina	SCSHD
Delaware	DELHD	Missouri	MOSHD	So. Dakota	SDSHD
Florida	FLAHD	Montana	MTSHD	Tennessee	TENHD
Georgia	GASHD	Nebraska	NBSHD	Texas	TEXHD
Idaho	IDSHD	Nevada	NVSHD	Utah	UTSHD
Illinois	ILLHD	New Hampshire	NHSHD	Vermont	VTSHD
Indiana	INDHC	New Jersey	NJSHD	Virginia	VASHD
Iowa	IASHC	New Mexico	NMSHD	Washington	WASHD
Kansas	KASHD	New York	NYSHD	W. Virginia	WVAHD
Kentucky	KYSHD	No. Carolina	NCSHD	Wisconsin	WISHD
Louisiana	LASHD	No. Dakota	NDSHD	Wyoming	WYOH

Example:-For Pennsylvania State Highway Department Use code "PASHD"
 For Iowa State Highway Commission Use code "IASHC"

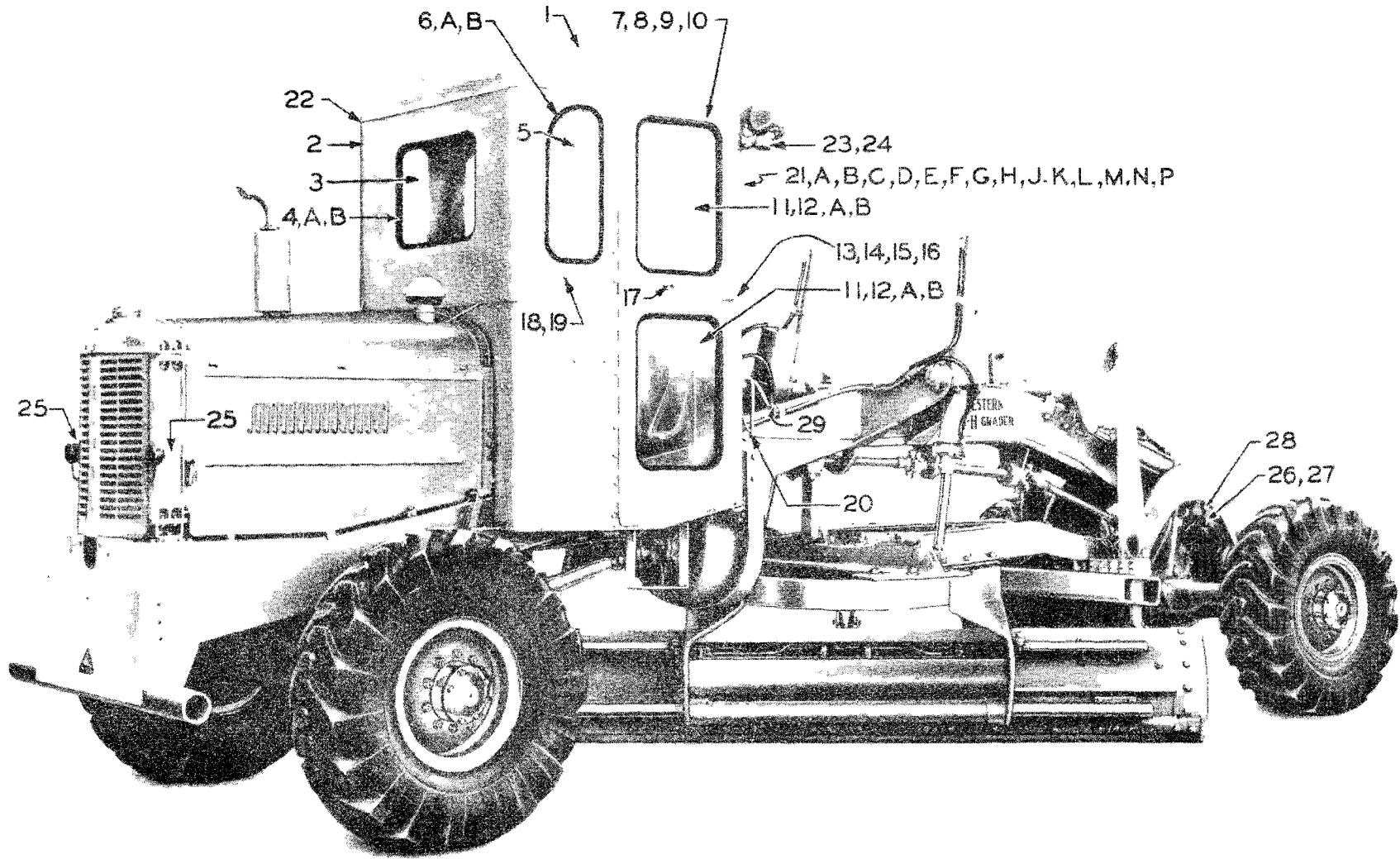

Figure 1. Miscellaneous Parts

B/M PGU-1854, 1856, 1914
PGU-1939, 1940, 1941

REF. NO.	PART NO.	QUANTITY	DESCRIPTION
1	PGF-9781	1	Cab top
2	PGF-9782	1	Wrapper sheet-upper
3	PGF-9634	1	Rear window glass
4	PGF-9642-2	1	Rear window glass rubber channel (no longer furnished. Order Ref. Nos. 4A and 4B)
4A	ASF-5883-3	1	Rear window glass rubber filler strip - 72" long
4B	ASF-5884-3	1	Rear window glass rubber molding - 77" long
5	PGF-9635	2	Cab side window
6	PGF-9642-1	2	Cab side window glass rubber channel (no longer furnished. Order 1 each Ref. Nos. 6A and 6B)
6A	ASF-5883-2	2	Cab side window glass rubber filler strip - 60" long
6B	ASF-5884-2	2	Cab side window glass rubber molding - 62 $\frac{1}{2}$ " long
7	PGF-9780	1	Door-right hand (includes Ref. Nos. 9 and 10)
8	PGF-9779	1	Door-left hand (includes Ref. Nos. 9 and 10)
9	PGF-9779-2	2	Sponge rubber weather strip - 116" long
10	PGF-9779-3	2	Sponge rubber weather strip - 65" long
11	PGF-9634	4	Door window glass
12	PGF-9642-2	4	Door window glass rubber channel (no longer furnished. Order 1 each Ref. Nos. 12A and 12B)
12A	ASF-5883-3	4	Door window glass rubber filler strip - 72" long
12B	ASF-5884-3	4	Door window glass rubber molding - 77" long
13	PGF-9636	1	Door handle-outside (right hand)
14	PGF-9632	1	Door lock-inside (right hand)
15	PGF-9637	1	Door handle-outside (left hand)
16	PGF-9633	1	Door lock-inside (left hand)
17	PG-1831	2	Door stop nut
18	PGF-8557	2	Door stop clamp
19	PGF-8555	2	Door stop crank
20	PGF-9271	4	Hand grip
21	PGF-9941	1	% Windshield frame
21A	PGF-10556	1	& Windshield frame
21B	PG-1338	2	Windshield arm
21C	PGF-4108	2	Windshield arm rivet
21D	PGF-10534	2	& Windshield arm anchor
21E	PGF-10543	6	& Windshield anchor shim
21F	PGF-9940	1	Windshield top angle
21G	PGF-9512	1	Windshield lower support
21H	PGF-9942	2	Windshield glass
21J	PGF-9646	1	Windshield glass top rubber molding
21K	PGF-9645	1	Windshield glass bottom rubber molding
21L	PGF-4111-6	2	Windshield glass side rubber molding
21M	PGF-9642-5	2	Windshield glass center rubber channel (no longer furnished. Order 1 each Ref. Nos. 21N and 21P)
21N	ASF-5883-4	2	Windshield glass center rubber filler strip - 32-7/8" long
21P	ASF-5884-4	2	Windshield glass center rubber molding - 32-7/8" long
22	PGF-9586-1	1	Fender welt
23	MS-380	2	Headlight socket
24	MS-381	2	Headlight socket washer
25	PGF-5164	2	Tail light bracket
26	PGF-7487	1	Hydraulic hose strap-front steer
27		2	Hose strap grommet (#1 G & W)
28	PGF-268	1	Hose strap spring
29	PGF-10216	10	Stud-pipe clamp to frame
	PGF-9054	1	* "U" bolt-front tow hook
	PGF-5212	1	* Draw bar bracket-rear
	PGF-9938	2	* Draw bar bracket bolt
	BTF-517	1	* Draw bar bracket pin
	PGF-10142	1	* Cover-propeller shaft grease opening
	MSF-1775	1	* Rear view mirror
	PGF-10369	1	* Mirror bracket
	PGF-10370	1	* Mirror bracket spacer
			- Curtains -
	PGF-10348	1	* Side curtain-right hand
	PGF-10350	1	* Side curtain-left hand
	PGF-10356	4	* Side curtain tie rope
	PGF-9858	24	* "D" ring
	PGF-1068	24	* "D" ring clamp

Note: % Last used on machine H-938.
& First used on machine H-940.

* Indicates parts not illustrated.

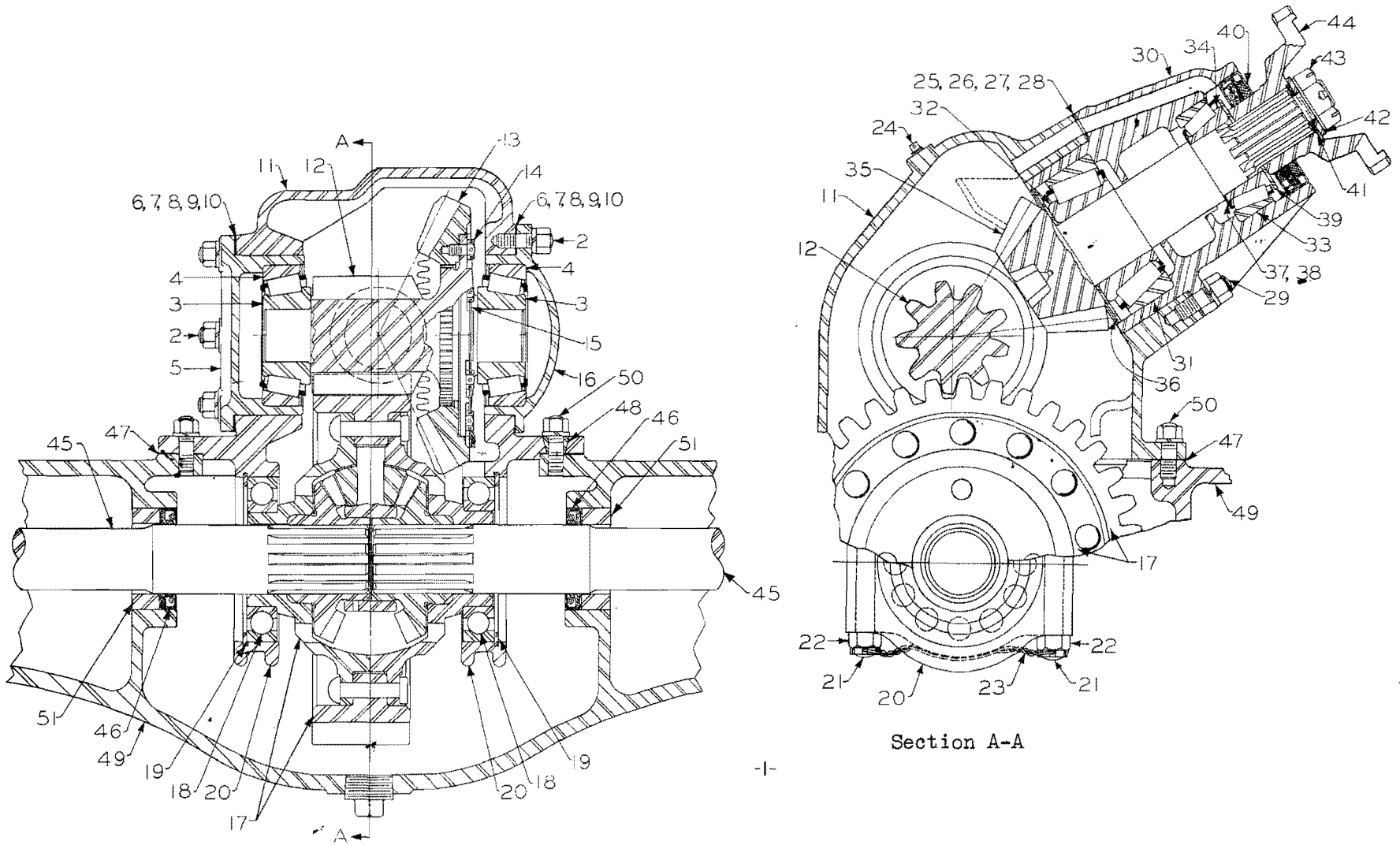

Figure 2. Front Axle Gear and Pinion Carrier

REF. NO.	PART NO.	QUANTITY	DESCRIPTION
1	PGU-1845	1	Front axle gear carrier group (includes Ref. Nos. 2 to 44 inclusive)
2	BTF-890	12	Stud
3	312245	2	Bearing cone and rollers
4	313098	2	Bearing cup
5	PGU-1658	1	Bearing cap with cup (includes 1 of Ref. No. 4)
6	PGF-3079	2	Gasket (paper)
7	PGF-3080	As req'd.	Shim - .005" thick
8	PGF-3081	As req'd.	Shim - .010" thick
9	PGF-3082	As req'd.	Shim - .030" thick
10	PGF-4288	As req'd.	Shim - .003" thick
11	PGU-1656	1	Gear carrier casting (includes Ref. Nos. 2, 20, 21, 22 and 23)
12	PGF-8609	1	Pinion and gear hub
13	PGF-8684	1	* Bevel gear
14	PGF-4194	6	Bevel gear screw
15	PGF-9436	1	Bevel gear screw locking wire
16	PGX-990	1	Bearing cap with cup (includes 1 of Ref. No. 4)
17	PGF-8602	1	# Differential group
18	311337	2	Differential hub ball bearing
19	PGF-3075	2	Differential bearing washer
20		2	@ Bearing cap
21	PGF-3087	4	Stud
22	727007	4	Castellated nut
23	PGF-9486	2	Locking wire
24	PGF-4184	1	Vent plug
25	PGF-8630	1	Gasket (paper)
26	PGF-8631	As req'd.	Shim - .003" thick
27	PGF-8632	As req'd.	Shim - .005" thick
28	PGF-8633	As req'd.	Shim - .010" thick
29	BTF-832	6	Stud
30	PG-1633	1	Pinion carrier
31	313209	1	Bearing cup
32	312549	1	Bearing cone and rollers
33	313448	1	Bearing cup
34	312991	1	Bearing cone and rollers
35	PGF-8686	1	* Bevel pinion
36	PGF-8595	1	Oil retainer
37	PGF-8714	As req'd.	Shim - .003" thick
38	PGF-8715	As req'd.	Shim - .015" thick
39	PGF-4852	1	Spline shaft washer
40	PGF-5240	1	Oil seal
41	PGF-4865	2	Washer gasket
42	PGF-4864	1	Washer
43	PGF-4667	1	Nut
44	MUJCO-5496-J	1	Fitting yoke
45	PGF-8586	2	Drive shaft or axle
46	PGF-8611	2	Oil seal
47	PGF-8610	1	Gasket
48	PGF-3084	1	Taper bushing
49	PGU-1655	1	Front axle housing with studs Ref. No. 50
50	BTF-890	14	Stud
51	PGF-9029	2	Spacer

Note: * Bevel gear and bevel pinion sold in matched sets only.
Differential repair parts not sold separately. Order complete differential group.
@ Bearing caps not sold separately. Order complete gear carrier casting, PGU-1656.

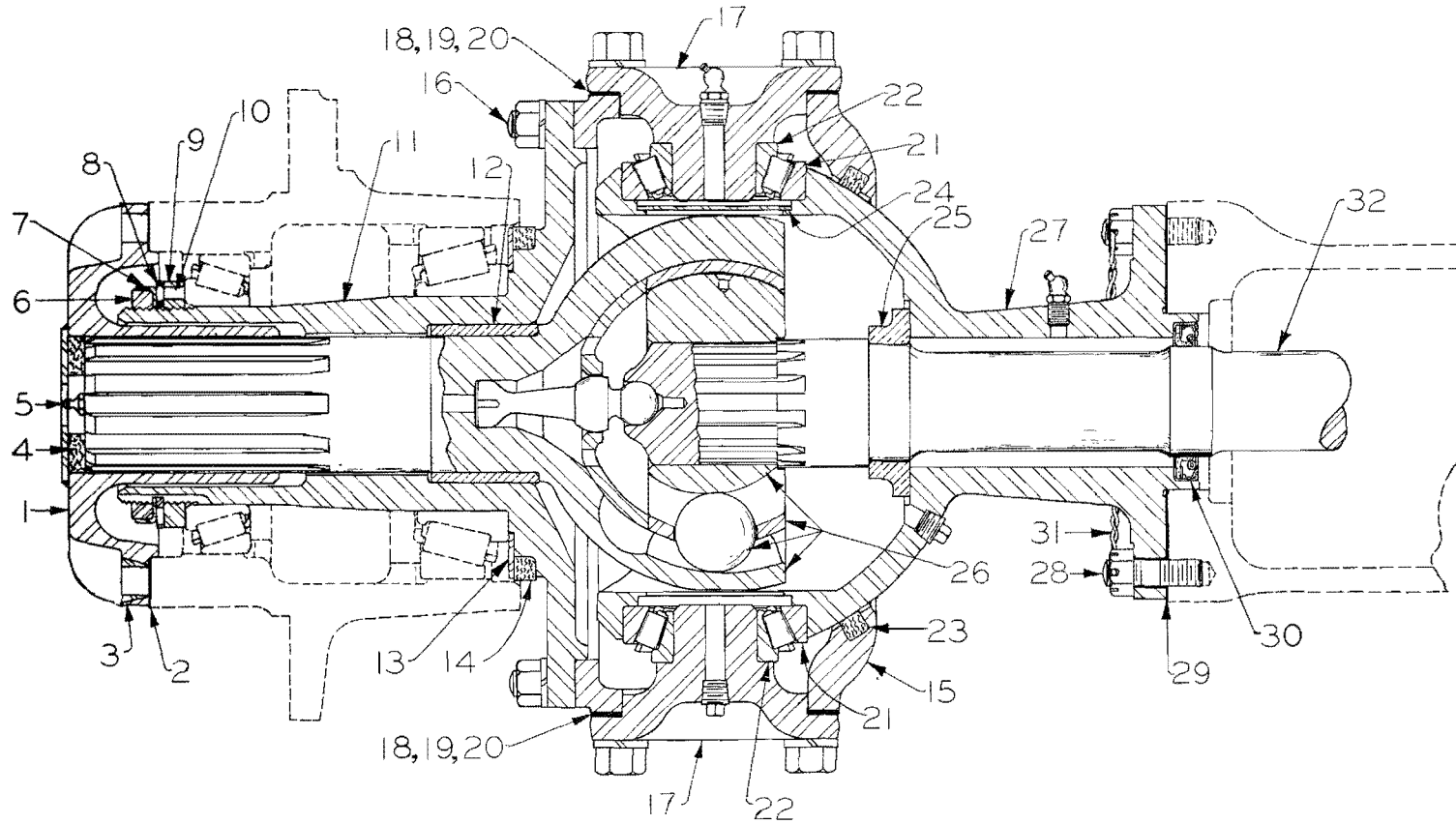

Figure 3. Front Axle Steering Knuckle and Universal Joint

REF. NO.	PART NO.	QUANTITY	DESCRIPTION
1	PGF-9377	1	Driving hub or flange
2	PGF-3186	1	Gasket
3	PGF-3610	4	Dowel bushing
4	PGF-7012	1	Felt
5	064456	1	Grease fitting
6	PGF-5436	1	Lock nut
7	PGF-5439	1	Lock washer
8	PGF-5438	1	Washer
9	PGU-5437	1	Adjusting nut with pin (includes Ref. No. 10)
10	PGF-3677	1	Adjusting nut pin
11	PGF-5433	1	Steering knuckle
12	PGF-5591	1	Steering knuckle bushing
13	PGF-4358	1	Washer
14	PGF-4360	1	Felt
15	PG-1795	1	Knuckle flange
16	PGF-4361	12	Stud
17	PGF-4341	2	Steer bearing cap
18	PGF-4345	As req'd.	Shim - .005" thick
19	PGF-4346	As req'd.	Shim - .007" thick
20	PGF-4347	As req'd.	Shim - .020" thick
21	313380	2	Bearing cup
22	312836	2	Bearing cone and rollers
23	PGF-4362	1	Felt
24	PGF-4339-2	1	Grease retainer
25	PG-1622	1	Axle retainer
26	PGF-8568	1	* Drive joint group
27	PGF-8804	1	Trunnion socket
28	PGF-4996	9	Stud
29	PGF-3184	1	Gasket
30	PGF-8611	1	Oil seal
31	PGF-9486	3	Locking wire
32		1	Drive shaft or axle

Note: * Drive joint repair parts not sold separately.
Order complete drive joint group.

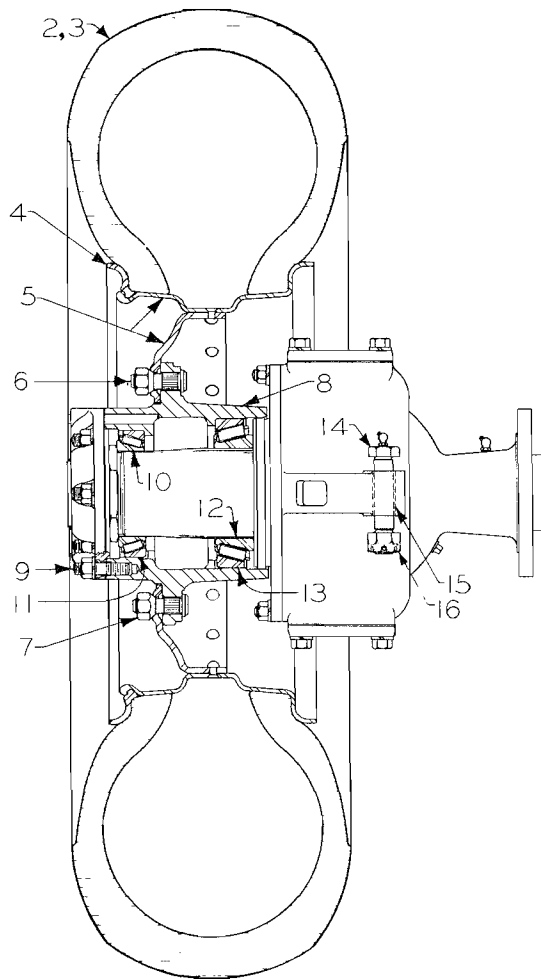

Figure 4. Front Axle Steering Knuckle, Wheel and Tire

REF. NO.	PART NO.	QUANTITY	DESCRIPTION
2		1	* Tire - 14.00 x 20 - 14 ply
3		1	Tube - 14.00 x 20 with TR-220 air-water valve
4	PGF-9392	1	Locking ring
5	PGF-9588	1	Wheel with rim
6	PGF-9391	10	Wheel stud
7	PGF-9396	10	Wheel stud nut
8	PGU-1695	1	Wheel hub with studs Ref. No. 9
9	BTF-831	8	Stud
10	312814	1	Bearing cone and rollers
11	313366	1	Bearing cup
12	312888	1	Bearing cone and rollers
13	313407	1	Bearing cup
14	PGF-8757	1	Fork bolt
15	PGF-8753	1	Knuckle flange bushing
16	727011	1	Castellated nut

Note: * Lug type-Road Grader

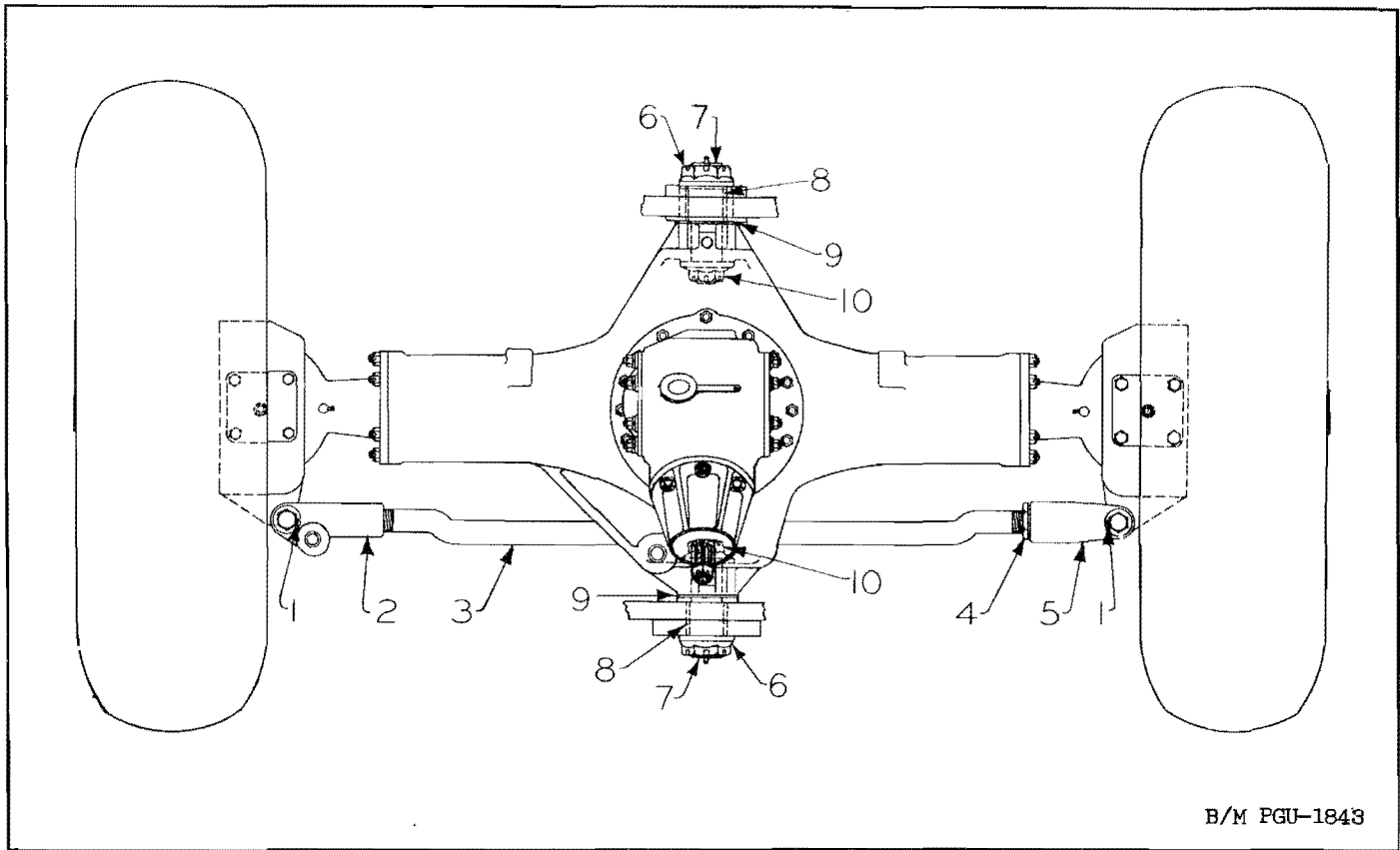

Figure 5. Front Axle Tie Rod and Axle Support

REF. NO.	PART NO.	QUANTITY	DESCRIPTION
1	PGF-5502	2	Pin
2	PG-1576	1	Fork
3	PGF-8835	1	Tie rod
4	PGF-3955	1	Adjusting nut
5	PG-1663	1	Fork
6	PG-1771	2	Nut
7	PGF-9087	2	Pivot pin
8	PGF-8738	2	Frame bushing
9	PGF-9263	2	Washer
10	PG-1649	2	Nut

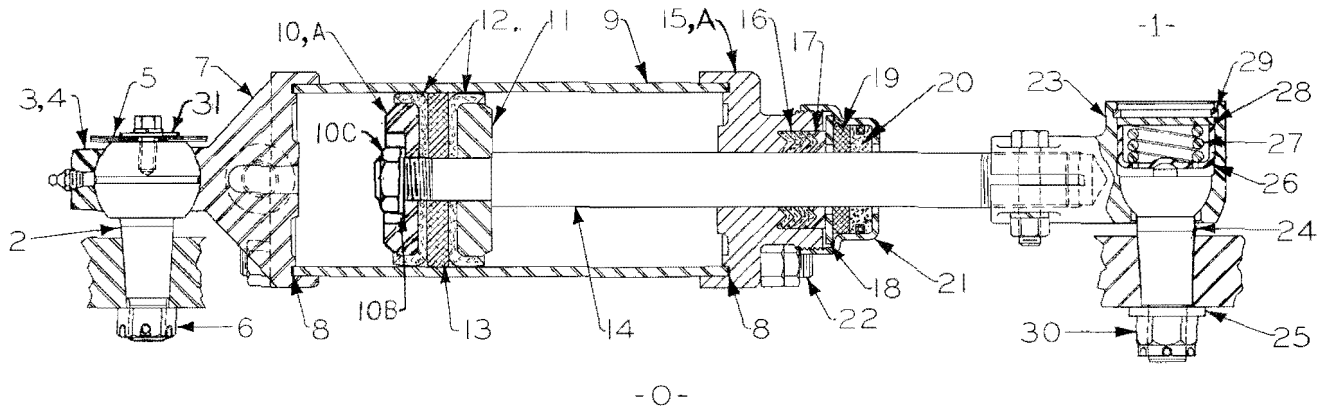

Figure 6. Front Axle Steering Ram

REF. NO.	PART NO.	QUANTITY	DESCRIPTION
0	PGU-1842-B	1	Steering ram group (includes Ref. Nos. 2 to 31 inclusive except Ref. Nos. 10 and 15)
1	PGUS-9206	1	Socket group (includes Ref. Nos. 23 to 30 inclusive)
2	PGF-8823	1	Ball stud
3	PGF-9487	1	Ball cap
4	MGF-1992	6	Ball cap shim
5	PGF-3318	1	Washer
6	734010	1	Slotted nut
7	PG-707	1	Base
8	PGF-1687	2	Gasket
9	PGF-8985	1	Cylinder
10	PGF-3047	1	Outer spreader (no longer furnished. Order Ref. Nos. 10A, 10B and 10C)
10A	PGF-10805	1	Outer spreader
10B	770020	1	Lock washer
10C	PGF-10807	1	Jam nut
11	PGF-3048	1	Inner spreader
12	PGF-8226	2	Cup
13	PG-694	1	Piston
14	PGF-8982	1	Piston rod
15	PG-1713	1	Head (no longer furnished. Order Ref. No. 15A)
15A	PG-1892	1	Head
16	PGF-1543	4	Chevron packing ring
17	PGF-8986	1	Press ring
18	PGF-7025	1	Retainer
19	PGF-7022	1	Felt
20	PGF-7026	1	Wiper
21	PGF-7019	1	Cap
22	PGF-8983	4	Tie rod
23	PGF-4256	1	Socket
24	PGF-9939	1	Ball stud
25	PGF-9944	1	Ball stud washer
26	PGF-4258	1	Spring seat
27	PGF-4259	1	Spring
28	PGF-4261	1	Plug
29	PGF-4260	1	Lock wire
30	727010	1	Castellated nut
31	PGF-10314	1	Washer plate

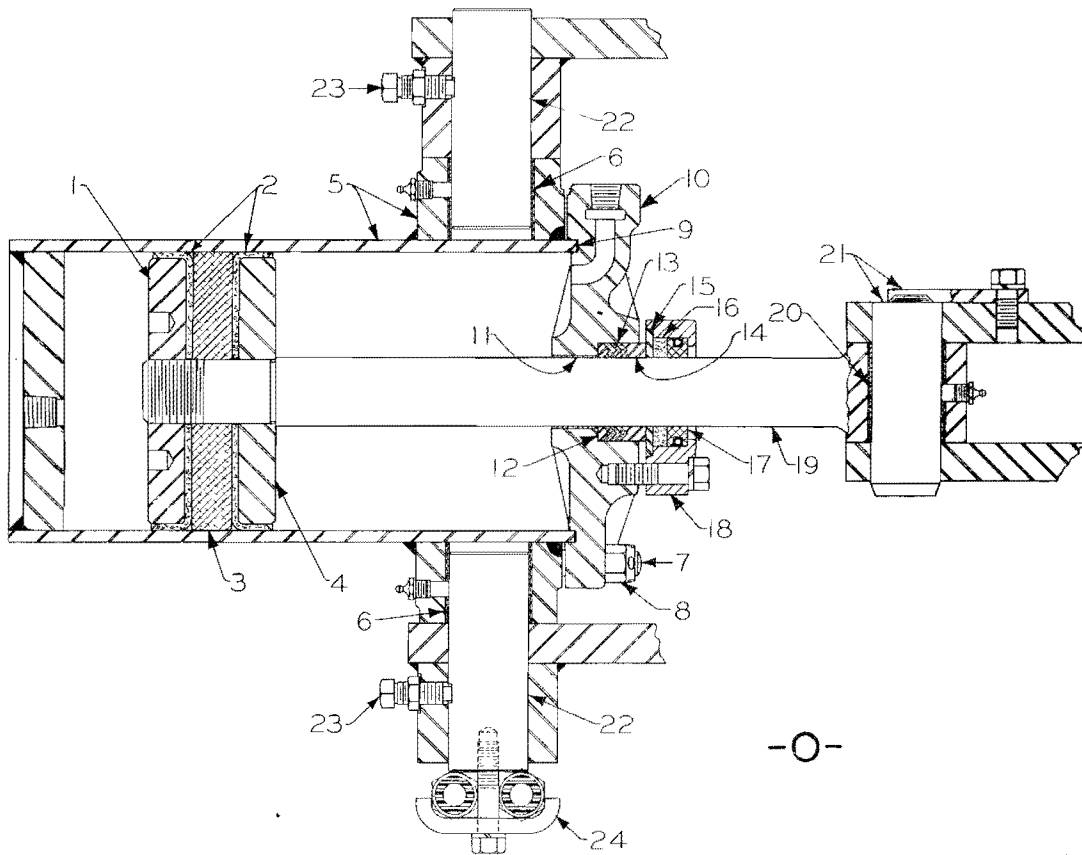
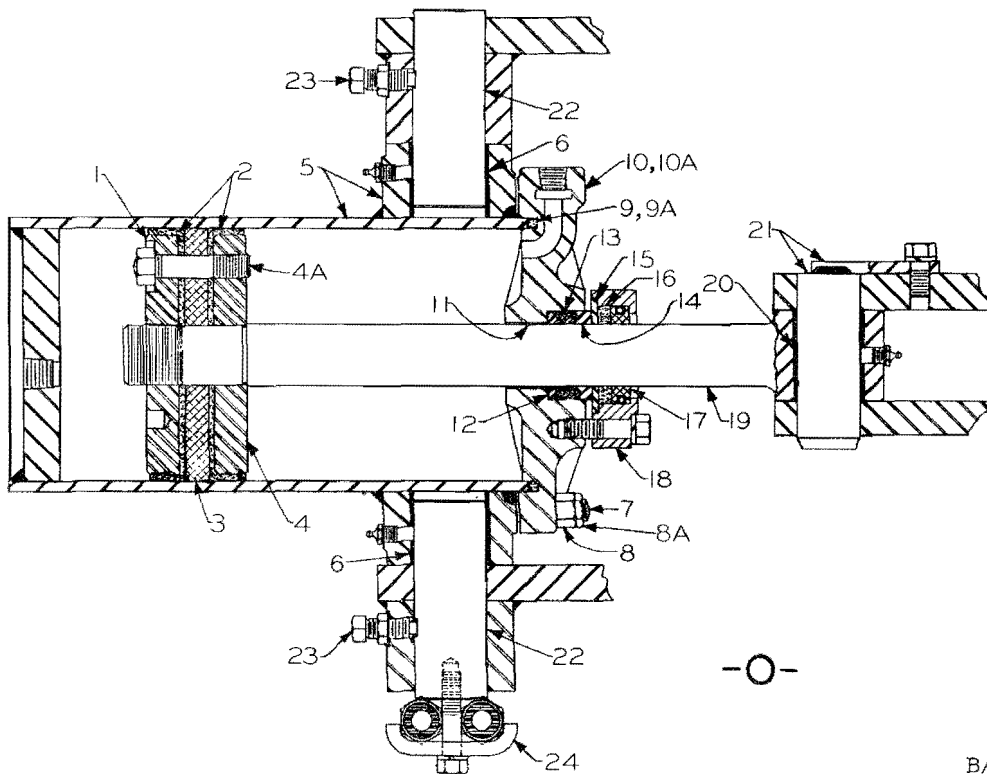

Figure 7. High Lift Ram
(Machines H-100 to H-320 inclusive)

REF. NO.	PART NO.	QUANTITY	DESCRIPTION
0	PGU-1907	1	High lift ram group (includes Ref. Nos. 1 to 20 inclusive)
1	PGF-9228	1	Outer spreader
2	HCF-198	2	Cup
3	HC-23	1	Piston
4	HCF-197	1	Inner spreader
5	PGF-9306	1	Cylinder
6	PGF-9227	2	Bushing
7	PGF-9305	10	Stud
8	727007	10	Castellated nut
9	HCF-200	1	Gasket
10	PG-1778	1	Head
11	PGF-9226	1	Head bushing
12	PGF-9220	1	Seal ring
13	PGF-9229	4	Chevron packing ring
14	PGF-9221	1	Press ring
15	PGF-9223	1	Retainer
16	PGF-9222	1	Felt
17	PGF-9225	1	Wiper
18	PG-1754	1	Cap
19	PGF-10485	1	Piston rod
20	PGF-9232	1	Bushing
21	PGF-9235	1	Rod pin
22	PGF-9224	2	Pivot pin
23	758094	2	Set screw-dog point
24	PGF-9530	1	Hose clamp



B/M PGU-1907-A,B

Figure 7A. High Lift Ram
(Machines H-322 and up)

REF. NO.	PART NO.	QUANTITY	DESCRIPTION
0	PGU-1907-B	1	High lift ram group (includes Ref. Nos. 1 to 20 inclusive except Ref. Nos. 9 and 10)
1	PGF-10489	1	Outer spreader
2	PGF-10487	2	Cup
3	PG-1909	1	Piston
4	PGF-10488	1	Inner spreader
4A	PGF-10486	4	Stud
5	PGF-9306	1	Cylinder
6	PGF-9227	2	Bushing
7	PGF-9305	10	Stud
8	722007	10	Hex nut
8A	724007	10	Pal nut
9	HCF-200	1	* Gasket
9A	PGF-9648-24	1	% "O" ring
10	PG-1778	1	* Head-uses gasket Ref. No. 9
10A	PG-1929	1	% Head-uses "O" ring Ref. No. 9A
11	PGF-9226	1	Head bushing
12	PGF-9220	1	Seal ring
13	PGF-9229	4	Chevron packing ring
14	PGF-9221	1	Press ring
15	PGF-9223	1	Retainer
16	PGF-9222	1	Felt
17	PGF-9225	1	Wiper
18	PG-1754	1	Cap
19	PGF-10485	1	Piston rod
20	PGF-9232	1	Bushing
21	PGF-9235	1	Rod pin
22	PGF-9224	2	Pivot pin
23	758094	2	Set screw-dog point
24	PGF-9530	1	Hose clamp

Note: * Last used on machine numbered H-1222.
% First used on machine numbered H-1224.

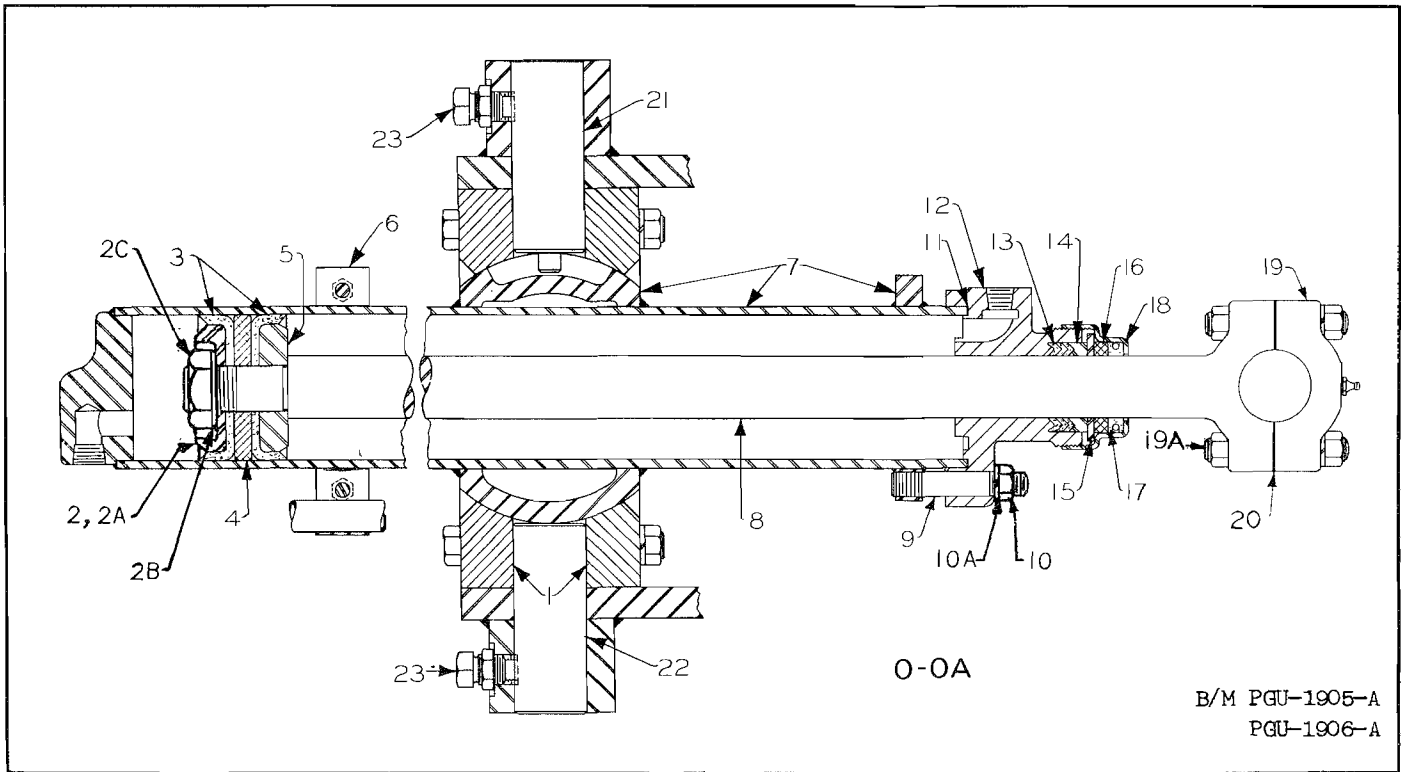

Figure 8. Blade Lift Ram

REF. NO.	PART NO.	QUANTITY	DESCRIPTION
0	PGU-1905-A	1	Blade lift ram group-right hand (includes Ref. Nos. 1 to 20 inclusive except Ref. No. 2)
OA	PGU-1906-A	1	Blade lift ram group-left hand (includes Ref. Nos. 1 to 20 inclusive except Ref. No. 2)
1	PGU-1694	1	Ball socket - 2 halves
2	PGF-1157	1	Outer spreader (no longer furnished. Order Ref. Nos. 2A, 2B and 2C)
2A	PGF-10804	1	Outer spreader
2B	770022	1	Lock washer
2C	726013	1	Jam nut
3	RGF-4378	2	Cup
4	PG-320	1	Piston
5	PGF-1158	1	Inner spreader
6	PGF-9521	1	Hose clamp
7	PGF-9242	1	Cylinder
8	PGF-9240	1	Piston rod
9	PGF-9241	4	Stud
10	722007	4	Hex nut
10A	778015	4	Lock washer
11	PGF-1687	1	Gasket
12	PG-1756	1	Head
13	PGF-9229	4	Chevron packing ring
14	PGF-9221	1	Press ring
15	PGF-9237	1	Retainer
16	PGF-9238	1	Felt
17	PGF-9239	1	Wiper
18	PGF-9243	1	Cap
19	PGF-9487	1	Ball cap
19A	PGF-10231	2	Ball cap stud
20	MGF-1992	6	Shim
21	PGF-9245	1	Pivot pin
22	PGF-9246	1	Pivot pin
23	758148	2	Set screw-dog point

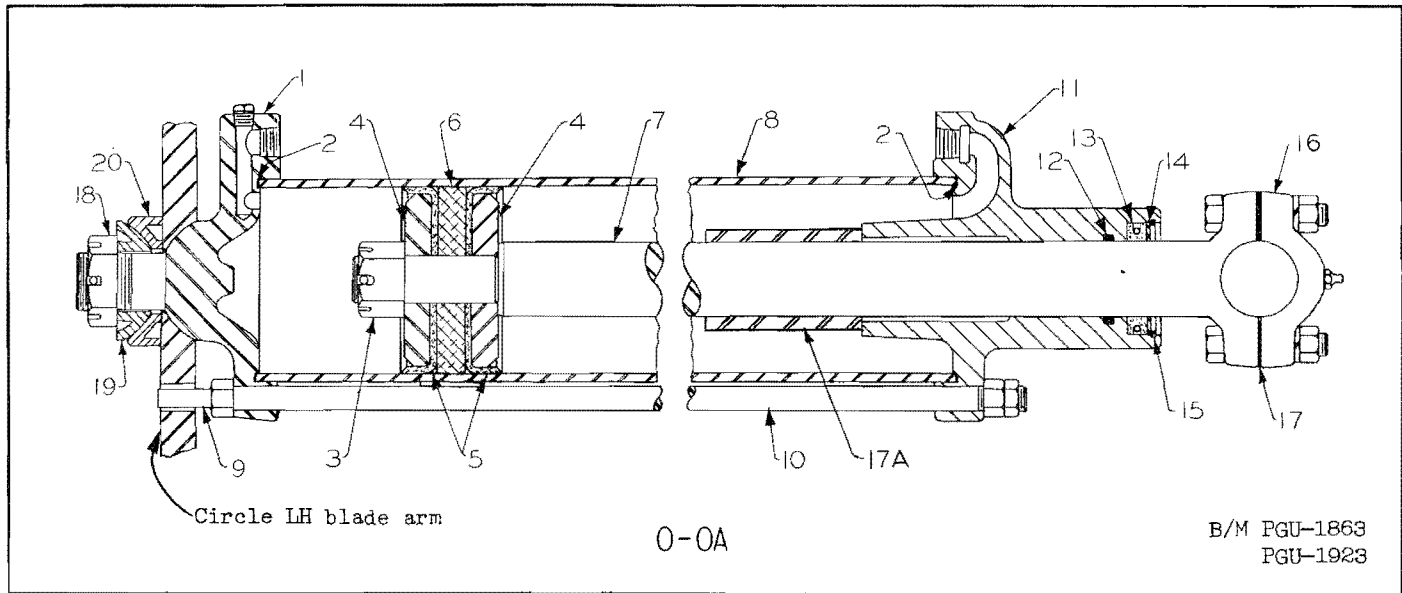

Figure 9. Blade Side Shift Ram
(Machines H-100 to H-902 inclusive)

REF. NO.	PART NO.	QUANTITY	DESCRIPTION
0	PGU-1863	1	* Blade side shift ram group (includes Ref. Nos. 1 to 17 inclusive)
0A	PGU-1923	1	¾ Blade side shift ram group (includes Ref. Nos. 1 to 17A inclusive)
1	PGF-9422	1	Base
2	PGF-1688	2	Gasket
3	737012	1	Slotted nut
4	PGF-3255	2	Spreader
5	PGF-5590	2	Cup
6	PG-862	1	Piston
7	PGF-9417	1	Piston rod
8	PGF-9418	1	Cylinder
9	PGF-9419	1	Tie rod
10	PGF-9415	4	Tie rod
11	PG-1791	1	Head (no longer furnished. Order PG-1910 head with 1, PGF-10084 felt)
12	PGF-9648-2	1	"O" ring
13	PGF-1727	1	Wiper
14	RGF-1293	1	Washer
15	PGF-9420	1	Snap ring
16	PGF-9487	1	Cap
17	MGF-1992	8	Shim
17A	PGF-10213	1	¾ Sleeve
18	PGF-3209	1	Ball plate nut
19	PG-890	1	Ball plate
20	PG-889	1	Ball socket

Note: * Indicates used on machines equipped with 13' blade.

¾ Indicates used on machines equipped with 12' blade.

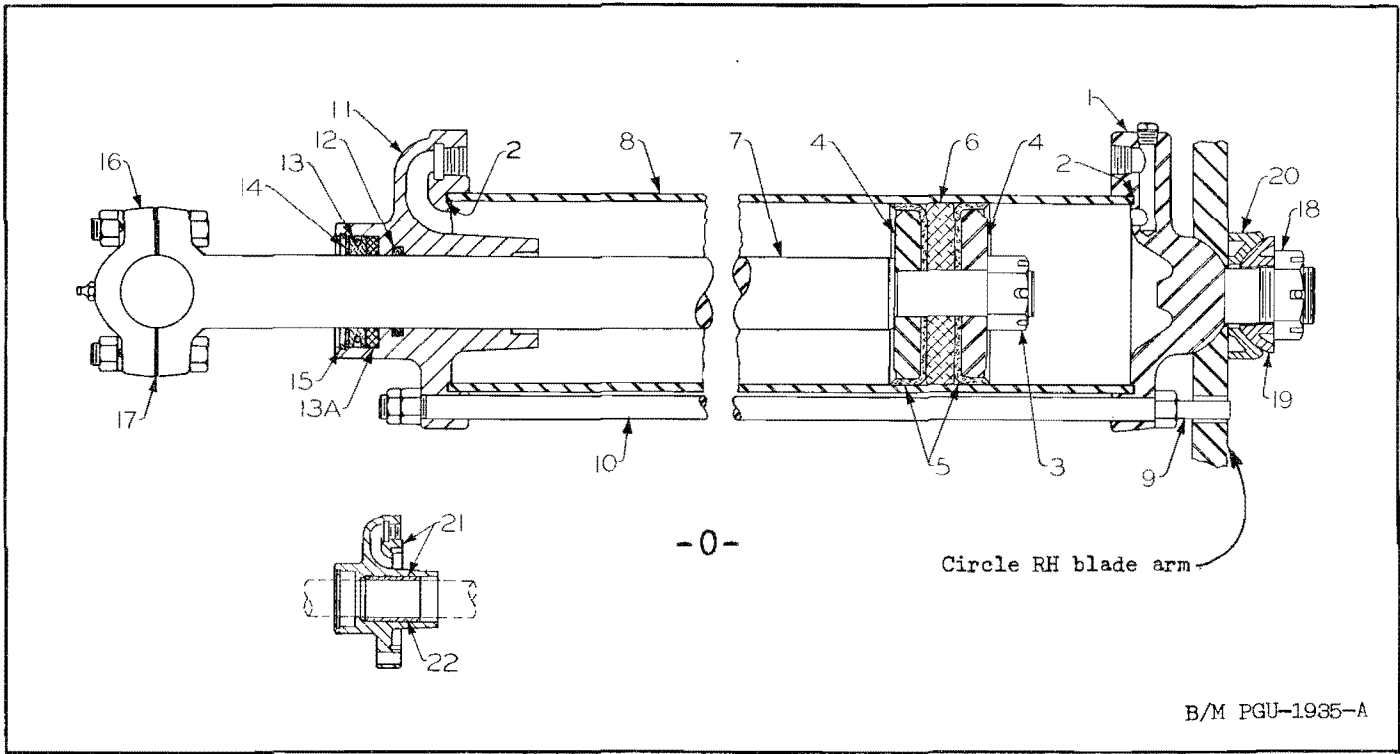
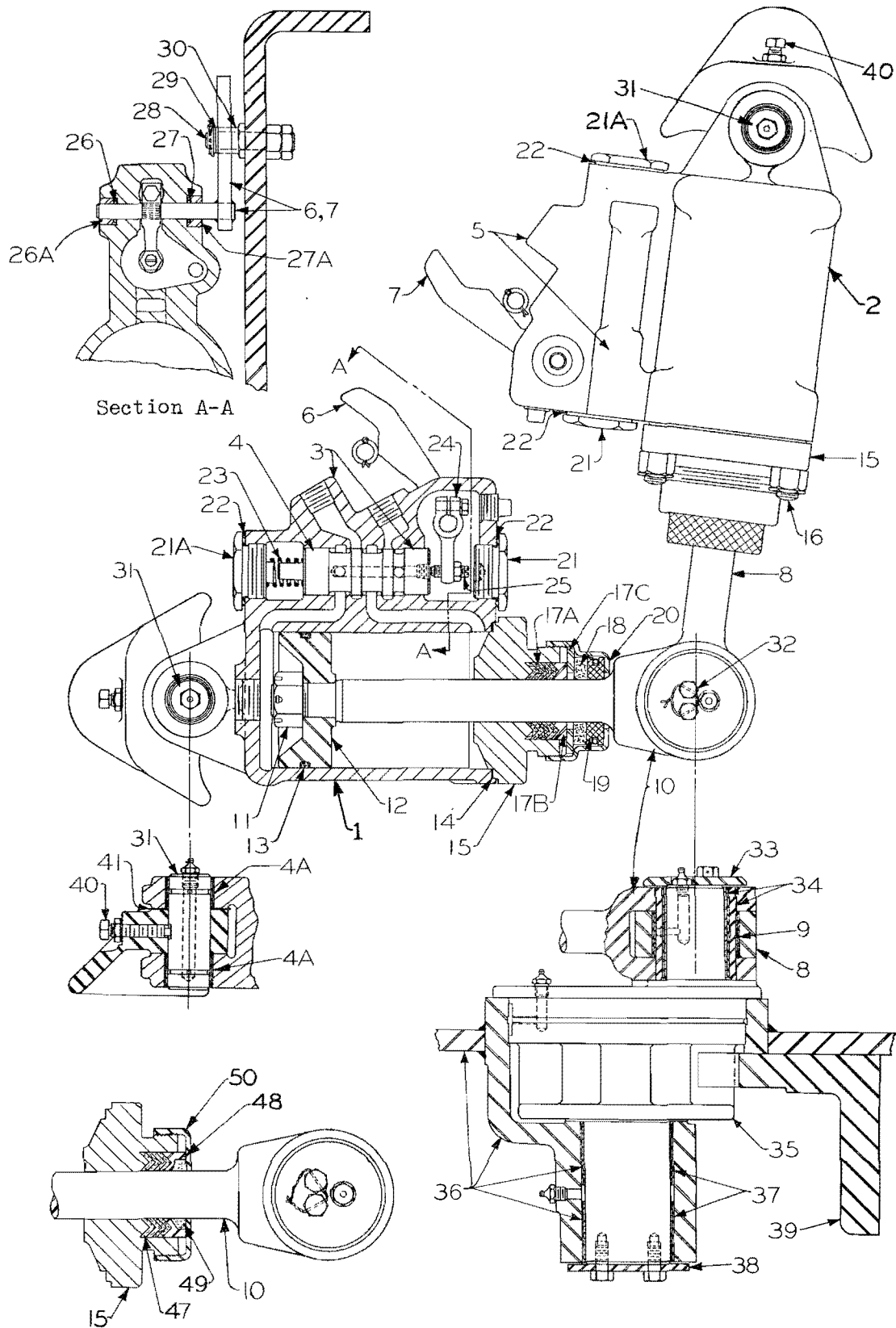

Figure 9A. Blade Side Shift Ram
(Machines H-904 and up)

REF. NO.	PART NO.	QUANTITY	DESCRIPTION
0	PGU-1935-A	1	Blade side shift ram group (includes Ref. Nos. 1 to 17 inclusive)
1	PGF-9422	1	Base
2	PGF-1688	2	Gasket
3	734013	1	Slotted nut
4	PGF-3255	2	Spreader
5	PGF-5590	2	Cup
6	PG-862	1	Piston
7	PGF-10501	1	Piston rod
8	PGF-10500	1	Cylinder
9	PGF-10499	1	Tie rod
10	PGF-10498	4	Tie rod
11	PG-1910	1	Head
12	PGF-9648-2	1	"O" ring
13	PGF-1727	1	Wiper
13A	PGF-10084	1	Felt
14	RGF-1293	1	Washer
15	PGF-9420	1	Snap ring
16	PGF-9487	1	Cap
17	MGF-1992	8	Shim
18	PGF-3209	1	Ball plate nut
19	PG-890	1	Ball plate
20	PG-889	1	Ball socket
21	PGP-10551	1	Head with bushing Ref. No. 22 (no longer furnished. Order PG-1910 head)
22	PGF-10550	1	Bushing



B/M PGU-1684, A

Figure 10. Circle Reverse Hydraulic Motor

REF. NO.	PART NO.	QUANTITY	DESCRIPTION
1	PGU-1683-A	1	Cylinder, valve and piston assembly-right hand (piston rod has forked end) (includes Ref. Nos. 3,6 and 10 to 27A inclusive)
2	PGU-1682-A	1	Cylinder, valve and piston assembly-left hand (piston rod has single bushed end) (includes Ref. Nos. 5,7,8 and 11 to 27A inclusive)
3	PGUS-9207	1	* Cylinder and valve body (R.H.) with valve and bushings (includes Ref. Nos. 4 and 4A)
4		1	* Valve plug (movable)
4A	PGF-8902	2	Body bushing
5	PGUS-9208	1	* Cylinder and valve body (L.H.) with valve and bushings (includes Ref. Nos. 4 and 4A)
6	PGF-9249	1	Valve control cam lever-right hand
7	PGF-9250	1	Valve control cam lever-left hand
8	PGU-1669	1	Piston rod with bushing (includes Ref. No. 9)
9	PGF-8909	1	Rod bushing
10	PGF-9761	1	Piston rod
11	734011	1	Slotted nut
12	PGF-9647	1	Piston
13	PGF-9648-1	1	"O" ring
14	PGF-9649	1	Gasket
15	PG-1826	1	Cylinder cap
16	PGF-9769	4	Stud
17A	PGF-1543	5	@ Chevron packing ring
17B	PGF-8986	1	@ Press ring
17C	PGF-7025	1	@ Retainer
18	PGF-7022	1	@ Felt
19	PGF-7026	1	@ Wiper
20	PGF-7019	1	@ Cap
21	PGF-9253	1	Plug
21A	PGF-10389	1	Plug
22	PGF-9161	2	Gasket
23	PGF-7938	1	Valve spring
24	PGF-8938	1	Valve actuating lever
25	PGF-8252	1	Adjusting screw
26	PGF-9648-22	1	"O" ring
26A	PGF-10365	1	"O" ring sleeve
27	PGF-9648-21	1	"O" ring
27A	PGF-10360	1	"O" ring sleeve
28	PGF-9619	2	Cam pin
29	PGF-8731	2	Cam pin washer
30	PGF-8728	2	Cam pin roller
31	PGF-8896	2	Pivot pin
32	ASF-3784	2	Cap screw
33	PGF-8243	1	Pinion retainer washer
34	PGU-1668	1	Bushing group
35	PG-1825	1	Pinion
36	PGU-1670	1	Circle front support with bushings Ref. No. 37
37	PGF-8908	2	Support hub bushing
38	PGF-8903	1	Pinion retainer washer
39		1	Circle
40	758058	2	Set screw-dog point
41	PGF-8248	As req'd.	Ram base shim
47	PGF-1543	4	% Chevron packing ring
48	PGF-9762	1	% Chevron seal ring
49	MGF-1558	1	% Felt
50	PGF-8325	1	% Cap

Note: * Movable valve plug not sold separately. Order Ref. No. 3, PGUS-9207, or Ref. No. 5, PGUS-9208.

% Machines H-100 to H-320 inclusive.

@ Machines H-322 and up.

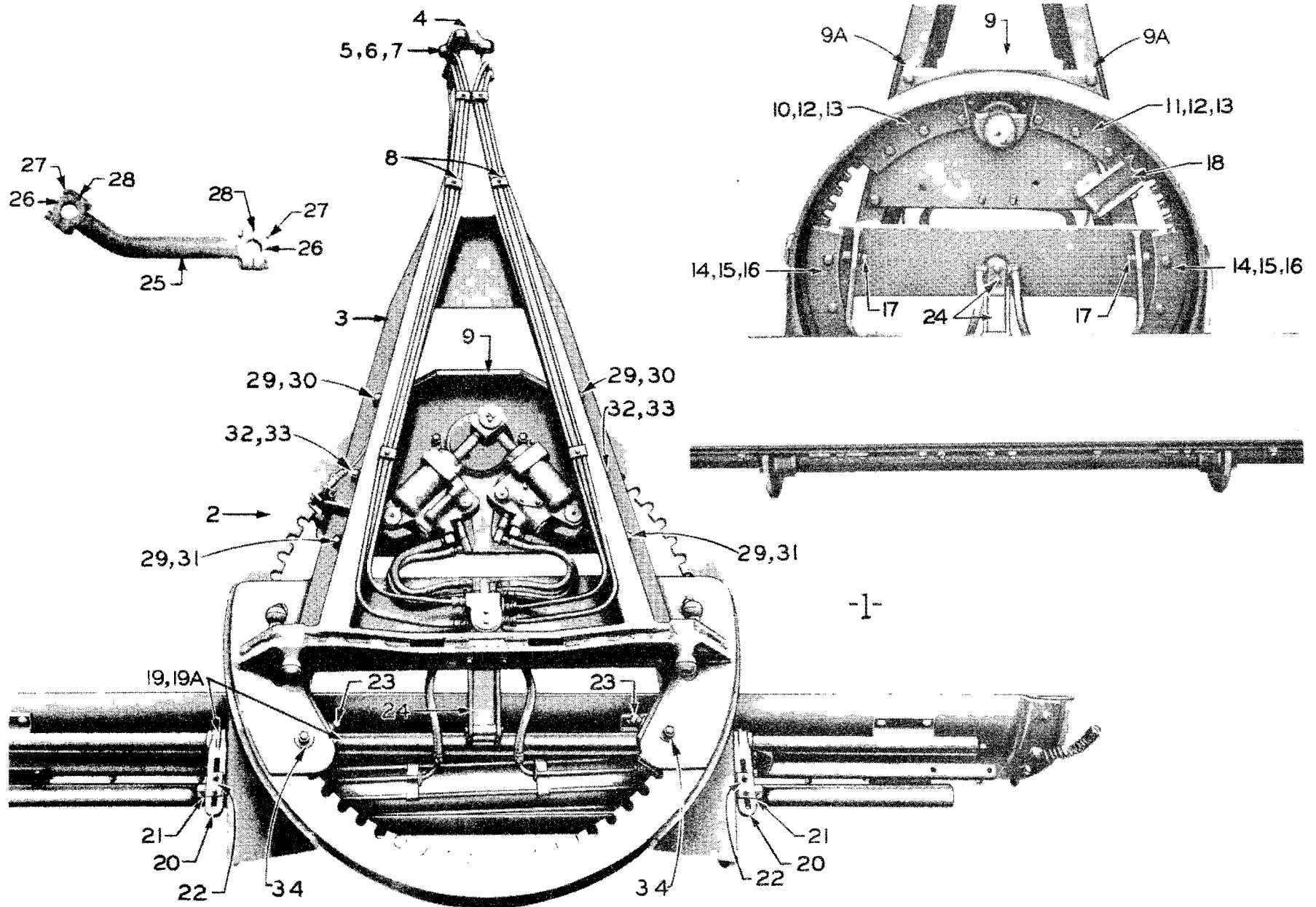

Figure 11. Circle and Draw Bar
(Machines H-100 to H-902 inclusive)

B/M PGU-1862, A

REF. NO.	PART NO.	QUANTITY	DESCRIPTION
1		1	Circle and draw bar group (no blade)
2	PGF-9748	1	Circle group
3	PGF-9616	1	Circle draw bar group (includes Ref. Nos. 4 and 5)
4	PGF-9236-3	1	Ball (welds on)
5	PG-1804	1	Ball cap
6	PG-1805	1	Ball socket
7	PGF-2314	12	Ball cap shim
8	PGF-7524	6	Pipe clamp
9	PGU-1670	1	Circle front support with bushings PGF-8908
9A	PGF-10358	6	Support plate shim - .023" thick
10	PGF-9618	1	Front circle support-right hand
11	PGF-9617	1	Front circle support-left hand
12	PGF-8948	As req'd.	Front circle support shim - .015" thick
13	PGF-8949	6	Front circle support shim - .032" thick
14	PGF-9620	2	Rear circle support
15	PGF-8565	As req'd.	Rear circle support shim - .015" thick
16	PGF-8931	As req'd.	Rear circle support shim - .032" thick
17	755288	2	Set screw-cup point
18	PGF-8996	1	Circle latch
19	PGF-8776	1	@ Tube with tilting links (includes Ref. No. 20)
19A	PGF-10502	1	% Tube with tilting links (includes Ref. No. 20)
20	PGF-8776-2	2	Tilt link (welds on)
21	PG-808	2	Anchor lug
22	PGF-8148	2	Anchor lug washer
23	755153	2	Set screw-cup point
24		1	Circle reverse junction block with plug and rotating linkage (see hydraulic piping page, Fig. 38)
25	PGF-9244	1	High lift link
26	PGF-9487	2	Ball cap
27	PGF-10231	4	Ball cap stud
28	MGF-1992	8	Ball cap shim
29	PGF-10474	4	* Bolt
30	PGF-10496	2	£ Bolt
31	PGF-10495	2	£ Bolt
32	742887	2	* Bolt
33	742890	2	£ Bolt
34	PGF-10607	6	Washer
	PGF-9752	1	Ram shield (not illustrated)
	PGF-8779	2	Ram shield clamp (not illustrated)

Note: @ Machines H-100 to H-442 inclusive.

% Machines H-444 and up.

* Machines H-100 to H-320 inclusive.

£ Machines H-322 and up.

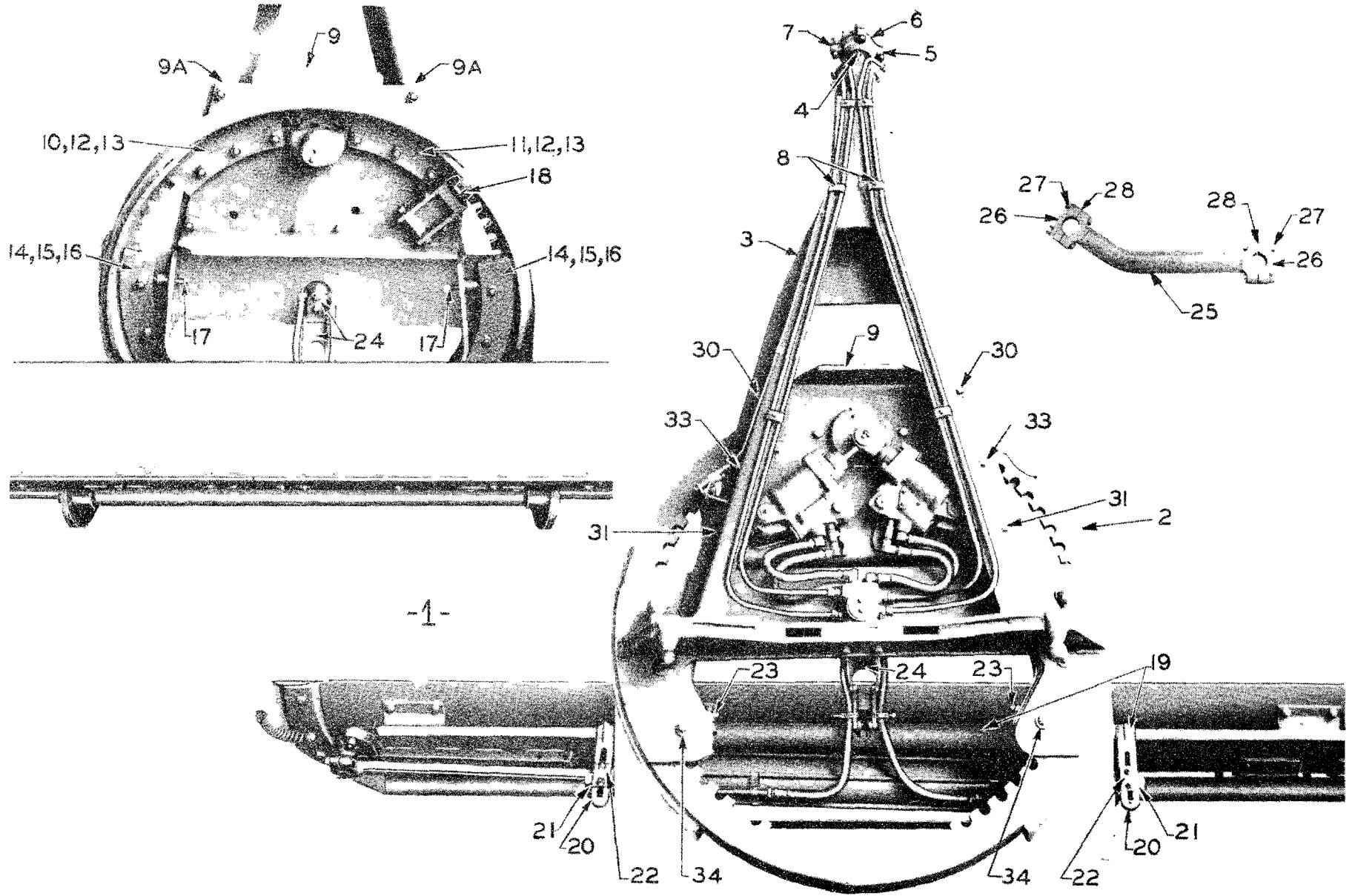

B/M PGU-1936

Figure 11A. Circle and Draw Bar
(Machines H-904 and up)

REF. NO.	PART NO.	QUANTITY	DESCRIPTION
1		1	Circle and draw bar group (no blade)
2	PGF-10504	1	Circle group
3	PGF-9616	1	Circle draw bar group (includes Ref. Nos. 4 and 5)
4	PGF-9236-3	1	Ball (welds on)
5	PG-1804	1	Ball cap
6	PG-1805	1	Ball socket
7	PGF-2314	12	Ball cap shim
8	PGF-7524	6	Pipe clamp
9	PGU-1670	1	Circle front support with bushings PGF-8908
9A	PGF-10358	6	Support plate shim - .023" thick
10	PGF-9618	1	Front circle support-right hand
11	PGF-9617	1	Front circle support-left hand
12	PGF-8948	As req'd.	Front circle support shim - .015" thick
	PGF-8949	6	Front circle support shim - .032" thick
14	PGF-9620	2	Rear circle support
15	PGF-8565	As req'd.	Rear circle support shim - .015" thick
16	PGF-8931	As req'd.	Rear circle support shim - .032" thick
17	755288	2	Set screw-cup point
18	PGF-8996	1	Circle latch
19	PGF-10502	1	Tube with tilting links (includes Ref. No. 20)
20	PGF-8776-2	2	Tilt link (welds on)
21	PG-808	2	Anchor lug
22	PGF-8148	2	Anchor lug washer
23	755153	2	Set screw-cup point
24		1	Circle reverse junction block with plug and rotating linkage (see hydraulic piping page, Fig. 38)
25	PGF-9244	1	High lift link
26	PGF-9487	2	Ball cap
27	PGF-10251	4	Ball cap stud
28	MGF-1992	8	Ball cap shim
30	PGF-10496	2	Bolt
31	PGF-10495	2	Bolt
33	742890	2	Bolt
34	PGF-10607	6	Washer
	PGF-9752	1	Ram shield (not illustrated)
	PGF-8779	2	Ram shield clamp (not illustrated)

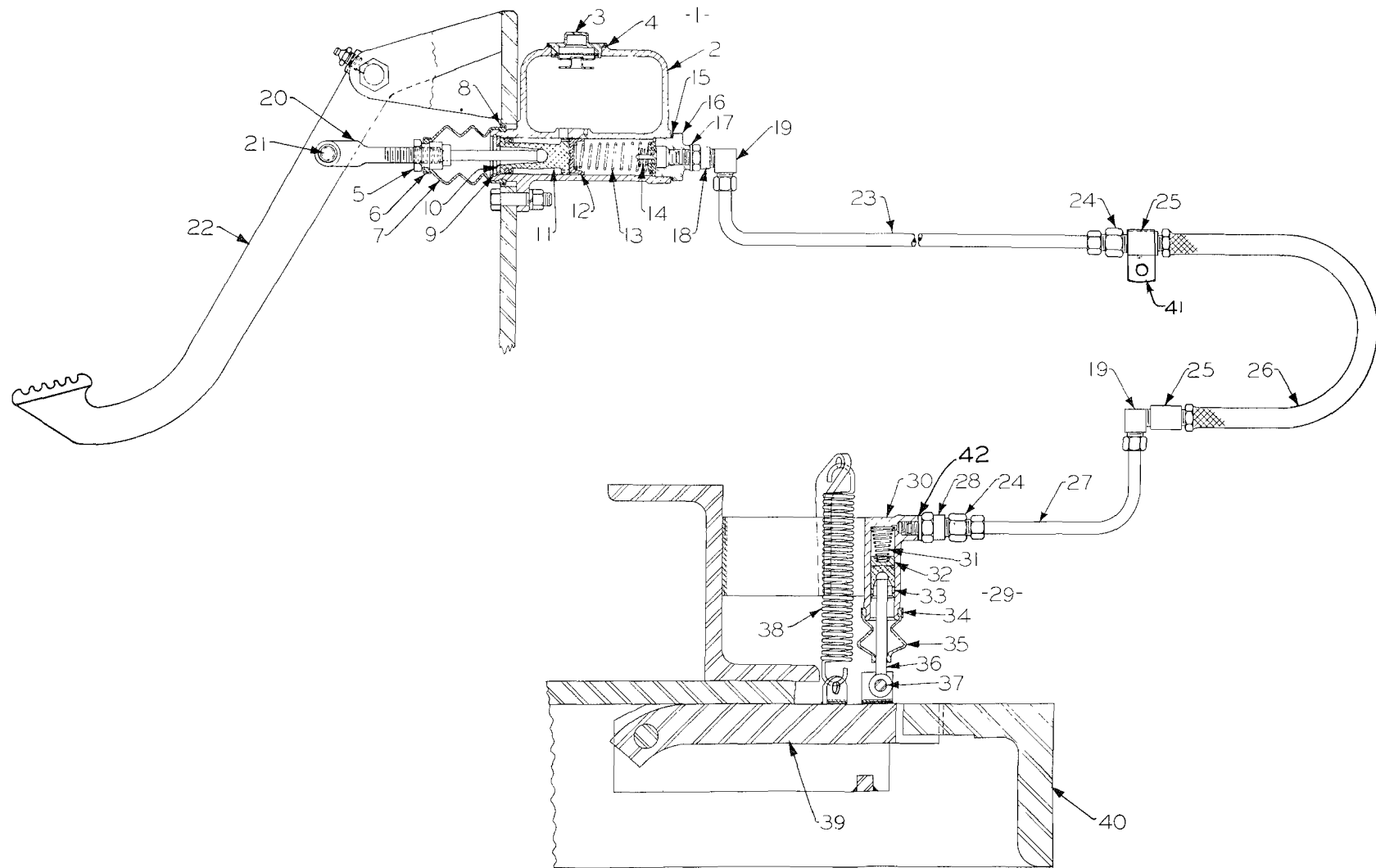

Figure 12. Circle Latch Mechanism

REF. NO.	PART NO.	QUANTITY	DESCRIPTION
1	PGF-9485	1	Master cylinder group (includes Ref. Nos. 2 to 16 inclusive)
2	WE-FD-4887	1	Supply tank
3	WE-FC-6018	1	Filler plug
4	WE-FC-6019	1	Filler plug gasket
5	WE-FC-2928	1	Piston link
6	WE-FC-939	1	Boot strap-small
7	WE-FC-2930	1	Boot
8	WE-FC-2931	1	Boot strap-large
9	WE-FC-3709	1	Piston stop wire
10	WE-FC-3710	1	Piston stop washer
11	WE-FC-3707	1	Piston group
12	WE-FD-2398	1	Cup
13	WE-FC-3572	1	Return spring
14	WE-FC-3578	1	Check valve group
15	WE-FC-3587	1	Head gasket
16	WE-FC-3861	1	Head
17	WE-FC-602	1	Gasket
18	789006	1	Connector
19	788007	1	Elbow
20	PGF-9766	1	Yoke
21	783005	1	Pin
22	PG-1827	1	Pedal
23	PGF-9483	1	Tube
24	786005	2	Connector-male
25	PGF-10519	2	Coupling
26	PGF-9437	1	Hose
27	PGF-10057	1	Tube
28	789004	1	Connector
29	PGF-8991	1	Cylinder group (includes Ref. Nos. 30 to 35 inclusive)
30	WE-FC-4156	1	Body
	WE-FC-2933	1	Bleeder screw (not illustrated)
31	WE-FC-4161	1	Return spring
32	WE-FC-4158	1	Cup
33	WE-FC-4160	1	Piston
34	WE-FC-4103	1	Boot strap
35	WE-FC-4162	1	Boot
36	PGF-9013	1	Piston rod
37	783004	1	Pin
38	PSF-1481	1	Spring
39	PGF-8996	1	Latch
40		1	Circle
41	ASF-3678	1	Clip
42	ASF-5451	1	Gasket

B/M PGU-1715, A
PGU-1915, A

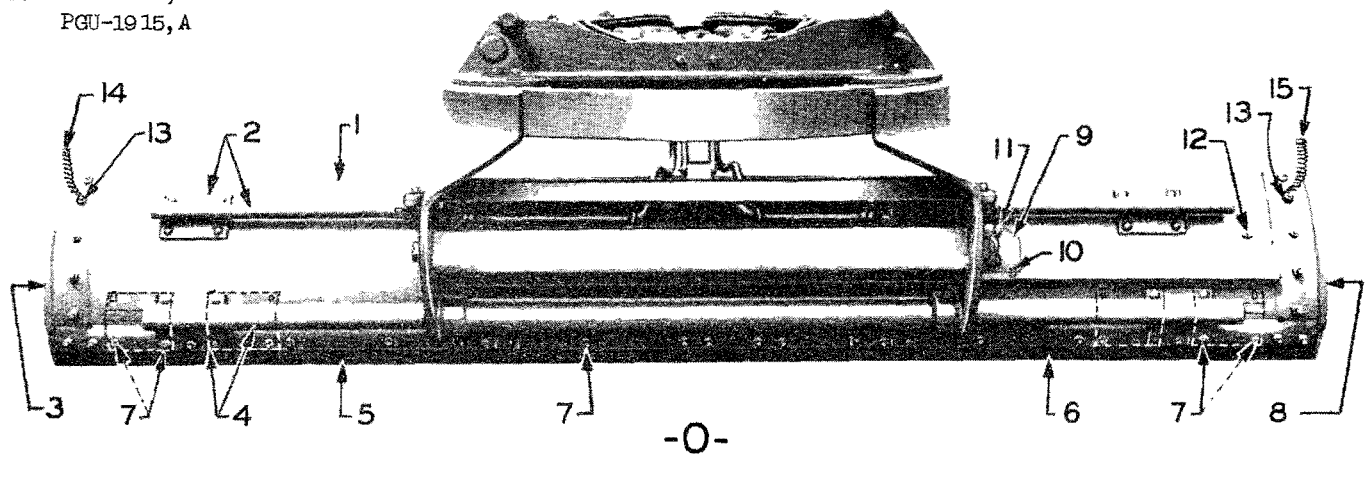

Figure 13. Blade

12' BLADE AND PARTS FOR MACHINES H-100 TO H-902 INCLUSIVE

REF. NO.	PART NO. (1st type)	PART NO. (2nd type)	QTY.	DESCRIPTION
0	PGU-1915	PGU-1915-A	1	Blade group (includes Ref. Nos. 1 to 13 incl.)
1	PGF-10215	PGF-10794	1	Moldboard
2	PGF-10211	PGF-10211	1	Upper shaft with supports (rivets to moldboard)
3	PGF-8897	PGF-8897	1	End bit-left hand
4	PGF-10212	PGF-10603	1	Lower tube with supports (rivets to moldboard)
5	RGF-2780-98	RGF-2780-98	1	Bit or cutting edge (L.H.) 5/8" x 6" x 6'
6	RGF-2780-99	RGF-2780-99	1	Bit or cutting edge (R.H.) 5/8" x 6" x 6'
7	RGF-6461		24	Bit Bolt
7		RGF-6461	26	Bit bolt
8	PGF-8898	PGF-8898	1	End bit-right hand
9	PGX-9749	PGX-9749	1	Side shift ball support (includes Ref. No. 10)
10	PGF-9270	PGF-9270	2	Ball support pin
11	RGF-6479	RGF-6479	1	Ball support bolt
12	PGF-10819	PGF-10819	1	Moldboard plug bolt
13	RGF-6462	RGF-6462	2	Flag socket bolt
14	PGF-10233	PGF-10233	1	Flag socket-left hand
15	PGF-10232	PGF-10232	1	Flag socket-right hand

13' BLADE AND PARTS FOR MACHINES H-100 TO H-902 INCLUSIVE

REF. NO.	PART NO. (1st type)	PART NO. (2nd type)	QTY.	DESCRIPTION
0	PGU-1715	PGU-1715-A	1	Blade group (includes Ref. Nos. 1 to 13 incl.)
1	PGF-9589	PGF-10707	1	Moldboard
2	PGF-9541	PGF-9541	1	Upper shaft with supports (rivets to moldboard)
3	PGF-8897	PGF-8897	1	End bit-left hand
4	PGF-9540	PGF-10602	1	Lower tube with supports (rivets to moldboard)
5	RGF-2764-98	RGF-2764-98	1	Bit or cutting edge (L.H.) 5/8" x 6" x 7'
6	RGF-2780-99	RGF-2780-99	1	Bit or cutting edge (R.H.) 5/8" x 6" x 6'
7	RGF-6461		25	Bit bolt
7		RGF-6461	27	Bit bolt
8	PGF-8898	PGF-8898	1	End bit-right hand
9	PGX-9749	PGX-9749	1	Side shift ball support (includes Ref. No. 10)
10	PGF-9270	PGF-9270	2	Ball support pin
11	RGF-6479	RGF-6479	1	Ball support bolt
12	PGF-10819	PGF-10819	1	Moldboard plug bolt
13	RGF-6462	RGF-6462	2	Flag socket bolt
14	PGF-10233	PGF-10233	1	Flag socket-left hand
15	PGF-10232	PGF-10232	1	Flag socket-right hand

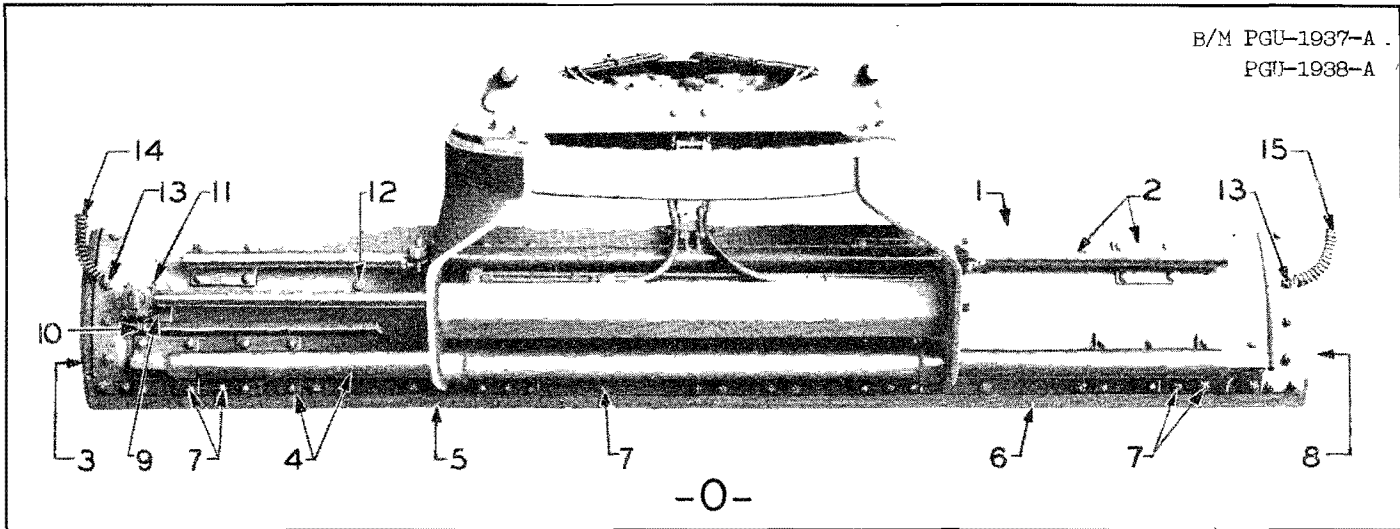

Figure 13A. Blade

12' BLADE AND PARTS FOR MACHINES H-904 AND UP

REF. NO.	PART NO.	QUANTITY	DESCRIPTION
0	PGU-1938-A	1	Blade group (includes Ref. Nos. 1 to 13 incl.)
1	PGF-10600	1	Moldboard
2	PGF-10505	1	Upper shaft with supports (rivets to moldboard)
3	PGF-8897	1	End bit-left hand
4	PGF-10603	1	Lower tube with supports (rivets to moldboard)
5	RGF-2780-98	1	Bit or cutting edge (L.H.) 5/8" x 6" x 6'
6	RGF-2780-99	1	Bit or cutting edge (R.H.) 5/8" x 6" x 6'
7	RGF-6461	26	Bit bolt
8	PGF-8898	1	End bit-right hand
9	PGX-10433	1	Side shift ball support (includes Ref. No. 10)
10	PGF-9270	2	Ball support pin
11	RGF-6479	1	Ball support bolt
12	PGF-10819	1	Moldboard plug bolt
13	RGF-6462	2	Flag socket bolt
14	PGF-10233	1	Flag socket-left hand
15	PGF-10232	1	Flag socket-right hand

13' BLADE AND PARTS FOR MACHINES H-904 AND UP

0	PGU-1937-A	1	Blade group (includes Ref. Nos. 1 to 13 incl.)
1	PGF-10599	1	Moldboard
2	PGF-9541	1	Upper shaft with supports (rivets to moldboard)
3	PGF-8897	1	End bit-left hand
4	PGF-10602	1	Lower tube with supports (rivets to moldboard)
5	RGF-2764-98	1	Bit or cutting edge (L.H.) 5/8" x 6" x 7'
6	RGF-2780-99	1	Bit or cutting edge (R.H.) 5/8" x 6" x 6'
7	RGF-6461	27	Bit bolt
8	PGF-8898	1	End bit-right hand
9	PGX-10433	1	Side shift ball support (includes Ref. No. 10)
10	PGF-9270	2	Ball support pin
11	RGF-6479	1	Ball support bolt
12	PGF-10819	1	Moldboard plug bolt
13	RGF-6462	2	Flag socket bolt
14	PGF-10233	1	Flag socket-left hand
15	PGF-10232	1	Flag socket-right hand

BLADE EXTENSIONS are provided to enlarge the usefulness of your machine for LIGHT WORK ONLY.

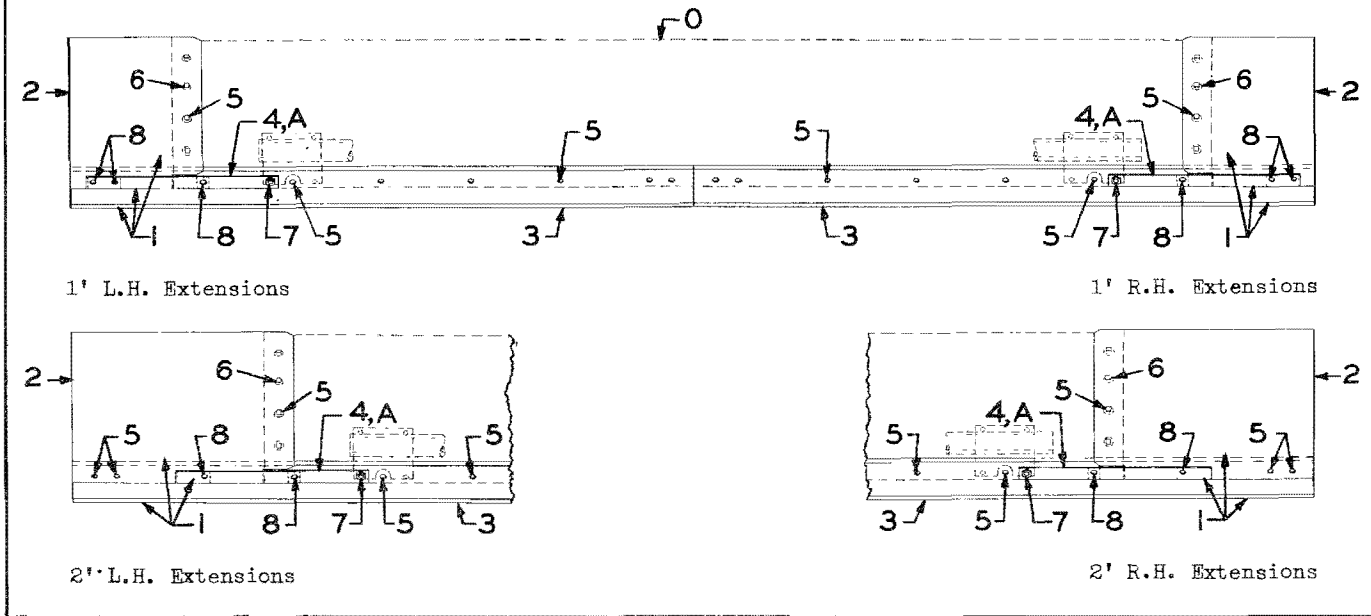

Figure 14. Blade Extensions and Cutting Edges

12' Blade Extensions for Machines H-100 to H-902 inclusive

REF.	DESCRIPTION	QTY.	1' LH EXT.	2' LH EXT.	1' RH EXT.	2' RH EXT.
0	Blade	1				
1	Extension group	1	PGU-1919	PGU-1922	PGU-1917	PGU-1920
2	Extension only	1	PGF-10207	PGF-10209	PGF-10208	PGF-10210
3	Bit	1	* RGF-2764-98	% RGF-2778-98	* RGF-2764-99	% RGF-2778-99
4	Stiffener	1	& PGF-10205	& PGF-10205	& PGF-10205	& PGF-10205
4A	Stiffener	1	@ PGF-10601	@ PGF-10601	@ PGF-10601	@ PGF-10601
5	Plow bolt	9	RGF-6461		RGF-6461	
5	Plow bolt	11		RGF-6461		RGF-6461
6	Plow bolt	1	RGF-6462	RGF-6462	RGF-6462	RGF-6462
7	Plow bolt	1	RGF-6473	RGF-6473	RGF-6473	RGF-6473
8	Plow bolt	3	708803		708803	
8	Plow bolt	2		708803		708803

13' Blade Extensions for Machines H-100 to H-902 inclusive

REF.	DESCRIPTION	QTY.	1' LH EXT.	2' LH EXT.	1' RH EXT.	2' RH EXT.
0	Blade	1				
1	Extension group	1	PGU-1918	PGU-1921	PGU-1917	PGU-1920
2	Extension only	1	PGF-10207	PGF-10209	PGF-10208	PGF-10210
3	Bit	1	% RGF-2778-98	£ RGF-2776-98	* RGF-2764-99	% RGF-2778-99
4	Stiffener	1	§ PGF-10205	§ PGF-10205	§ PGF-10205	§ PGF-10205
4A	Stiffener	1	¢ PGF-10601	¢ PGF-10601	¢ PGF-10601	¢ PGF-10601
5	Plow bolt	10	RGF-6461			
5	Plow bolt	12		RGF-6461		
5	Plow bolt	9			RGF-6461	
5	Plow bolt	11				RGF-6461
6	Plow bolt	1	RGF-6462	RGF-6462	RGF-6462	RGF-6462
7	Plow bolt	1	RGF-6473	RGF-6473	RGF-6473	RGF-6473
8	Plow bolt	3	708803		708803	
8	Plow bolt	2		708803		708803

Note: * Indicates 5/8" x 6" x 7' bit or cutting edge. & First type used with PGU-1915 blade group.
 % Indicates 5/8" x 6" x 8' bit or cutting edge. @ Second type used with PGU-1915-A blade group.
 £ Indicates 5/8" x 6" x 9' bit or cutting edge. § First type used with PGU-1715 blade group.
 ¢ Second type used with PGU-1715-A blade group.

Blade bits or cutting edges are always shipped with the necessary bolts and nuts for installation unless otherwise specified.

BLADE EXTENSIONS are provided to enlarge the usefulness of your machine for LIGHT WORK ONLY.

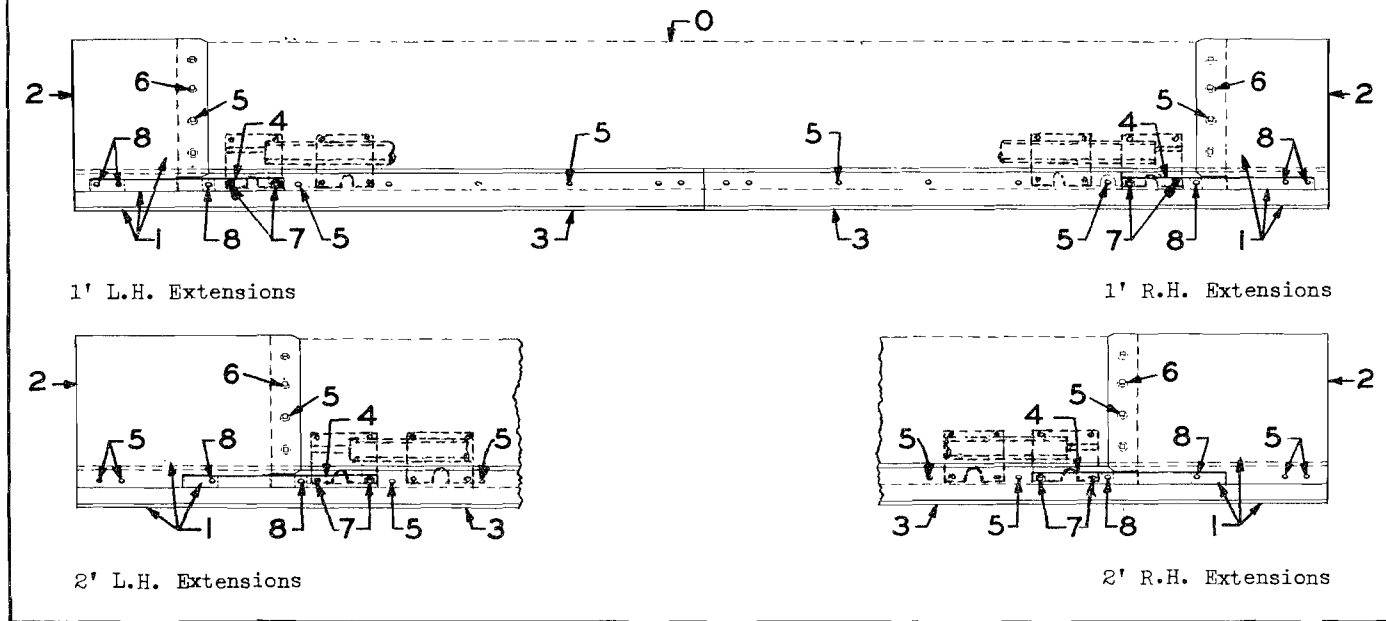

Figure 14A. Blade Extensions and Cutting Edges

12' Blade Extensions for Machines H-904 and up

REF.	DESCRIPTION	QTY.	1' LH EXT.	2' LH EXT.	1' RH EXT.	2' RH EXT.
0	Blade	1				
1	Extension group	1	PGU-1919-A	PGU-1922-A	PGU-1917-A	PGU-1920-A
2	Extension only	1	PGF-10207	PGF-10209	PGF-10208	PGF-10210
3	Bit	1	* RGF-2764-98	‡ RGF-2778-98	* RGF-2764-99	‡ RGF-2778-99
4	Stiffener	1	PGF-10601	PGF-10601	PGF-10601	PGF-10601
5	Plow bolt	9	RGF-6461		RGF-6461	
5	Plow bolt	11		RGF-6461		RGF-6461
6	Plow bolt	1	RGF-6462	RGF-6462	RGF-6462	RGF-6462
7	Plow bolt	2	RGF-6473	RGF-6473	RGF-6473	RGF-6473
8	Plow bolt	3	708803		708803	
8	Plow bolt	2		708803		708803

13' Blade Extensions for Machines H-904 and up

REF.	DESCRIPTION	QTY.	1' LH EXT.	2' LH EXT.	1' RH EXT.	2' RH EXT.
0	Blade	1				
1	Extension group	1	PGU-1918-A	PGU-1921-A	PGU-1917-A	PGU-1920-A
2	Extension only	1	PGF-10207	PGF-10209	PGF-10208	PGF-10210
3	Bit	1	‡ RGF-2778-98	£ RGF-2776-98	* RGF-2764-99	‡ RGF-2778-99
4	Stiffener	1	PGF-10601	PGF-10601	PGF-10601	PGF-10601
5	Plow bolt	10	RGF-6461			
5	Plow bolt	12		RGF-6461		
5	Plow bolt	9			RGF-6461	
5	Plow bolt	11				RGF-6461
6	Plow bolt	1	RGF-6462	RGF-6462	RGF-6462	RGF-6462
7	Plow bolt	2	RGF-6473	RGF-6473	RGF-6473	RGF-6473
8	Plow bolt	3	708803		708803	
8	Plow bolt	2		708803		708803

Note: * Indicates 5/8" x 6" x 7' bit or cutting edge.
 ‡ Indicates 5/8" x 6" x 8' bit or cutting edge.
 £ Indicates 5/8" x 6" x 9' bit or cutting edge.
 Blade bit or cutting edges are always shipped with the necessary bolts and nuts for installation unless otherwise specified.

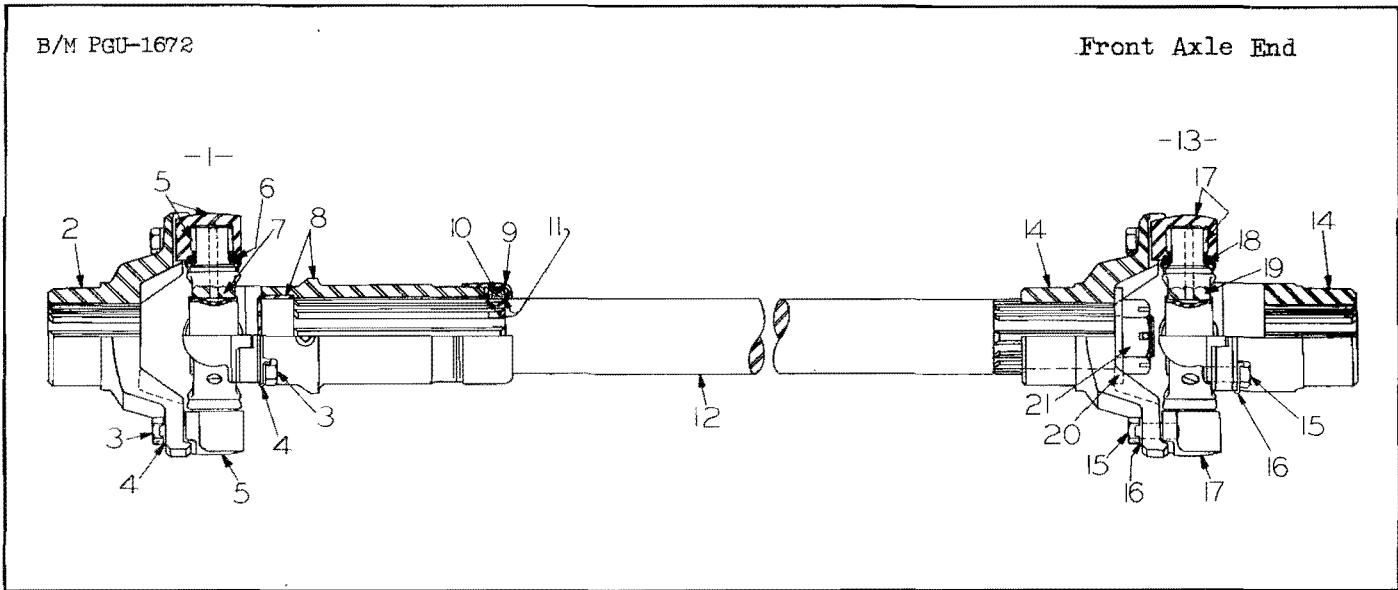

Figure 15. Front Section of Front Propeller Shaft

REF. NO.	PART NO.	QUANTITY	DESCRIPTION
1	PGF-8607	1	Knuckle group (includes Ref. Nos. 2 to 11 inclusive)
	MUJCO-114-7012	1	Spider and bearing group (includes Ref. Nos. 3, 4, 5, 6 and 7)
2	MUJCO-5496-J	1	Fitting yoke
3	MUJCO-3562-J	8	Cap screw
4	MUJCO-3551-J	4	Cap screw lock plate
5	MUJCO-113-7002	4	Bearing group
6	MUJCO-3571-J	4	Cork trunnion washer
7	MUJCO-112-7004	1	Spider group
8	MUJCO-6A-7017	1	Slip yoke group
9	MUJCO-863-J	1	Felt retainer
10	MUJCO-1479-J	1	Felt washer
11	MUJCO-1473-J	2	Retainer washer
12	PGF-8864	1	Shaft
13	PGF-8588	1	Knuckle group (includes Ref. Nos. 14 to 19 inclusive)
	MUJCO-114-7012	1	Spider and bearing group (includes Ref. Nos. 15, 16, 17, 18 and 19)
14	MUJCO-5496-J	2	Fitting yoke
15	MUJCO-3562-J	8	Cap screw
16	MUJCO-3551-J	4	Cap screw lock plate
17	MUJCO-113-7002	4	Bearing group
18	MUJCO-3571-J	4	Cork trunnion washer
19	MUJCO-112-7004	1	Spider group
20	PGF-4864	1	Washer
21	PGF-4667	1	Nut

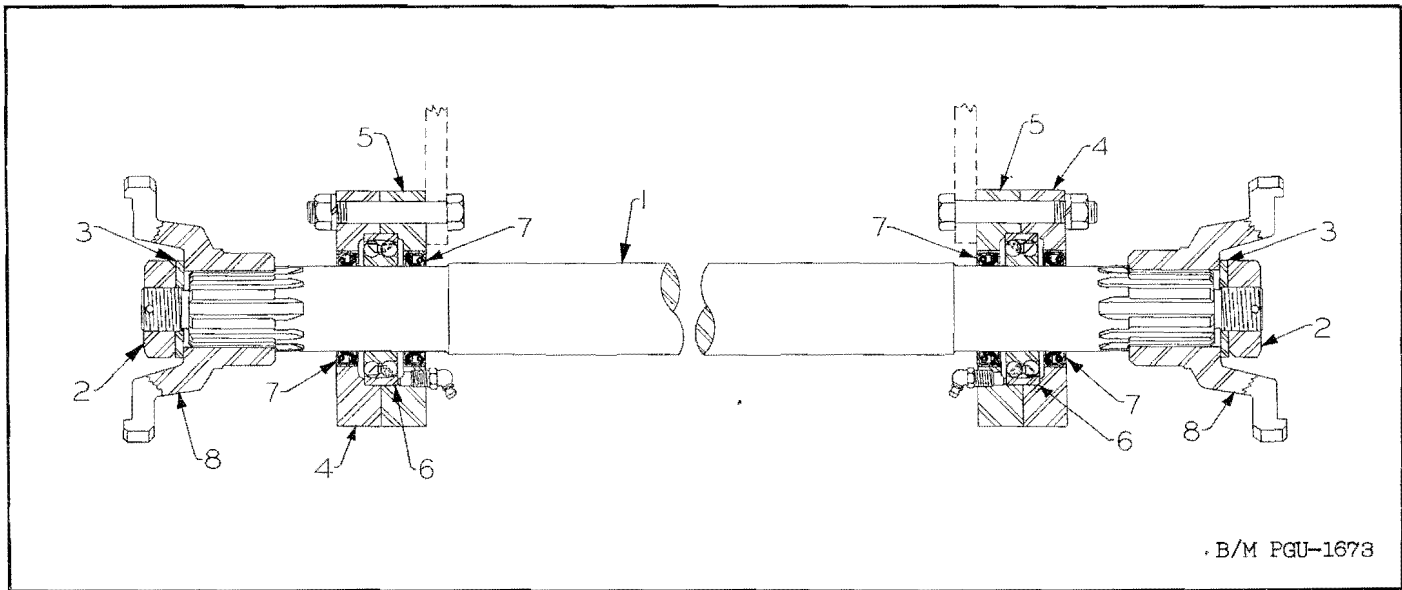

Figure 16. Center Section of Front Propeller Shaft

REF. NO.	PART NO.	QUANTITY	DESCRIPTION
1	PGF-8865	1	Shaft
2	PGF-4667	2	Nut
3	PGF-4864	2	Washer
4	PGF-10140	2	Bearing housing-outer
5	PGF-10141	2	Bearing housing-inner
6	314060	2	Ball bearing
7	PGF-8861	4	Oil seal
8	MUJCO-5496-J	2	Fitting yoke

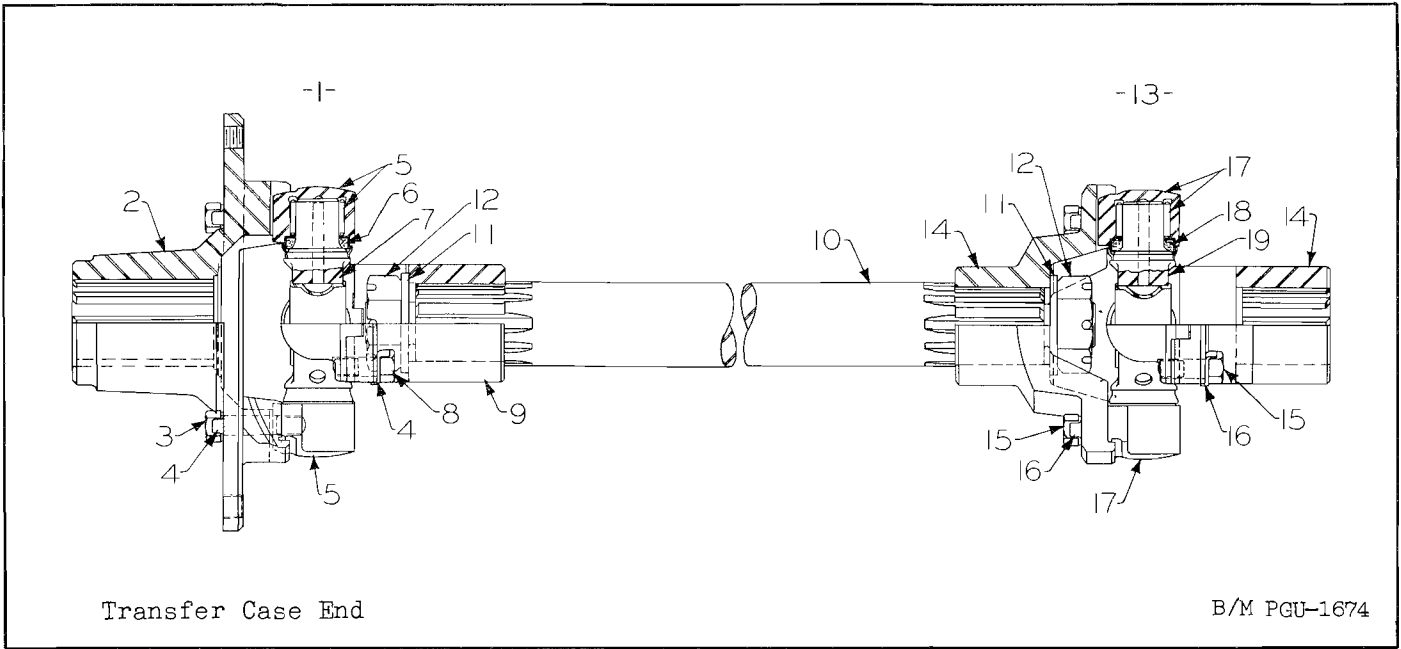

Figure 17. Rear Section of Front Propeller Shaft

REF. NO.	PART NO.	QUANTITY	DESCRIPTION
1	PGF-8807	1	Knuckle and brake flange group (includes Ref. Nos. 2 to 9 inclusive)
	MUJCO-114-7011	1	Spider and bearing group (includes Ref. Nos. 3,4,5,6,7 and 8)
2	MUJCO-7169-J	1	Brake flange
3	MUJCO-7174-J	4	Brake flange cap screw
4	MUJCO-3551-J	4	Cap screw lock plate
5	MUJCO-113-7002	4	Bearing group
6	MUJCO-3571-J	4	Cork trunnion washer
7	MUJCO-112-7004	1	Spider group
8	MUJCO-3562-J	4	Cap screw
9	MUJCO-5496-J	1	Fitting yoke
10	PGF-9248	1	Shaft
11	PGF-4864	2	Washer
12	PGF-4667	2	Nut
13	PGF-8588	1	Knuckle group (includes Ref. Nos. 14 to 19 inclusive)
	MUJCO-114-7012	1	Spider and bearing group (includes Ref. Nos. 15,16,17,18 and 19)
14	MUJCO-5496-J	2	Fitting yoke
15	MUJCO-3562-J	8	Cap screw
16	MUJCO-3551-J	4	Cap screw lock plate
17	MUJCO-113-7002	4	Bearing group
18	MUJCO-3571-J	4	Cork trunnion washer
19	MUJCO-112-7004	1	Spider group

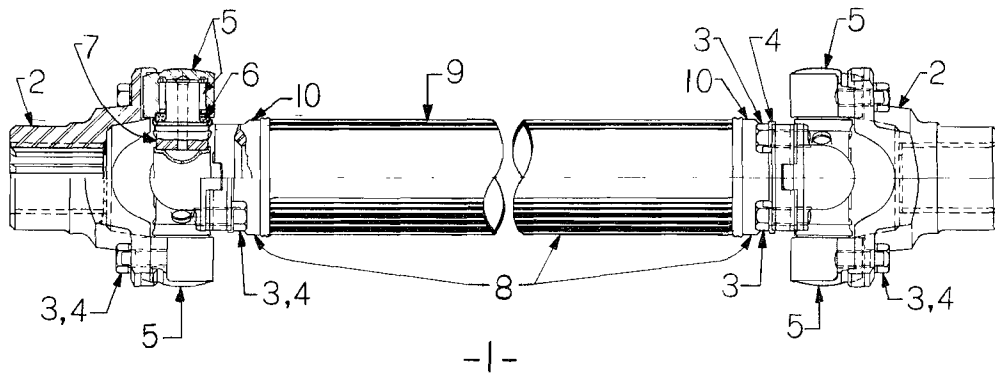
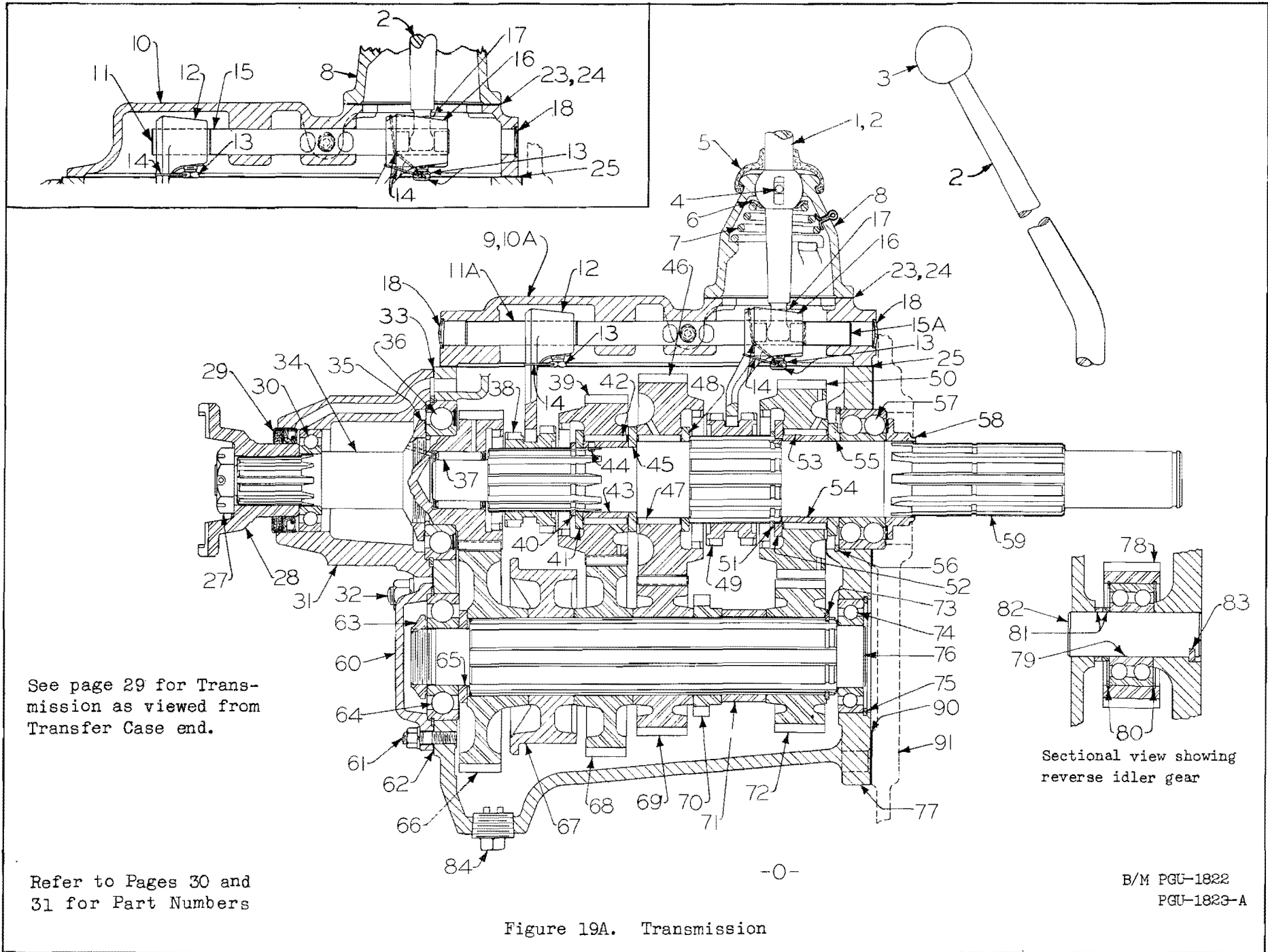

Figure 18. Propeller Shaft ^{for UD-14A Engine}
(Clutch to Transmission)

REF. NO.	PART NO.	QUANTITY	DESCRIPTION
1	PGF-9079	1	Propeller shaft, complete
	MUJCO-114-5014	2	Spider and bearing group (includes Ref. Nos. 3,4,5,6 and 7)
2	MUJCO-5116-J	2	Fitting yoke
3	MUJCO-3544-J	16	Cap screw
4	MUJCO-3550-J	8	Cap screw lock plate
5	MUJCO-113-5003	8	Bearing group
6	MUJCO-3543-J	8	Cork trunnion washer
7	MUJCO-112-5003	2	Spider group
8	MUJCO-42-4276	1	Propeller tube group (includes Ref. Nos. 9 and 10)
9	MUJCO-4369-J-278	1	Tube (only)
10	MUJCO-3536-J	2	Weld yoke



See page 29 for Transmission as viewed from Transfer Case end.

Refer to Pages 30 and 31 for Part Numbers

Sectional view showing reverse idler gear

Figure 19A. Transmission

B/M PGU-1822
PGU-1823-A

See page 28 for cross section side view of Transmission.

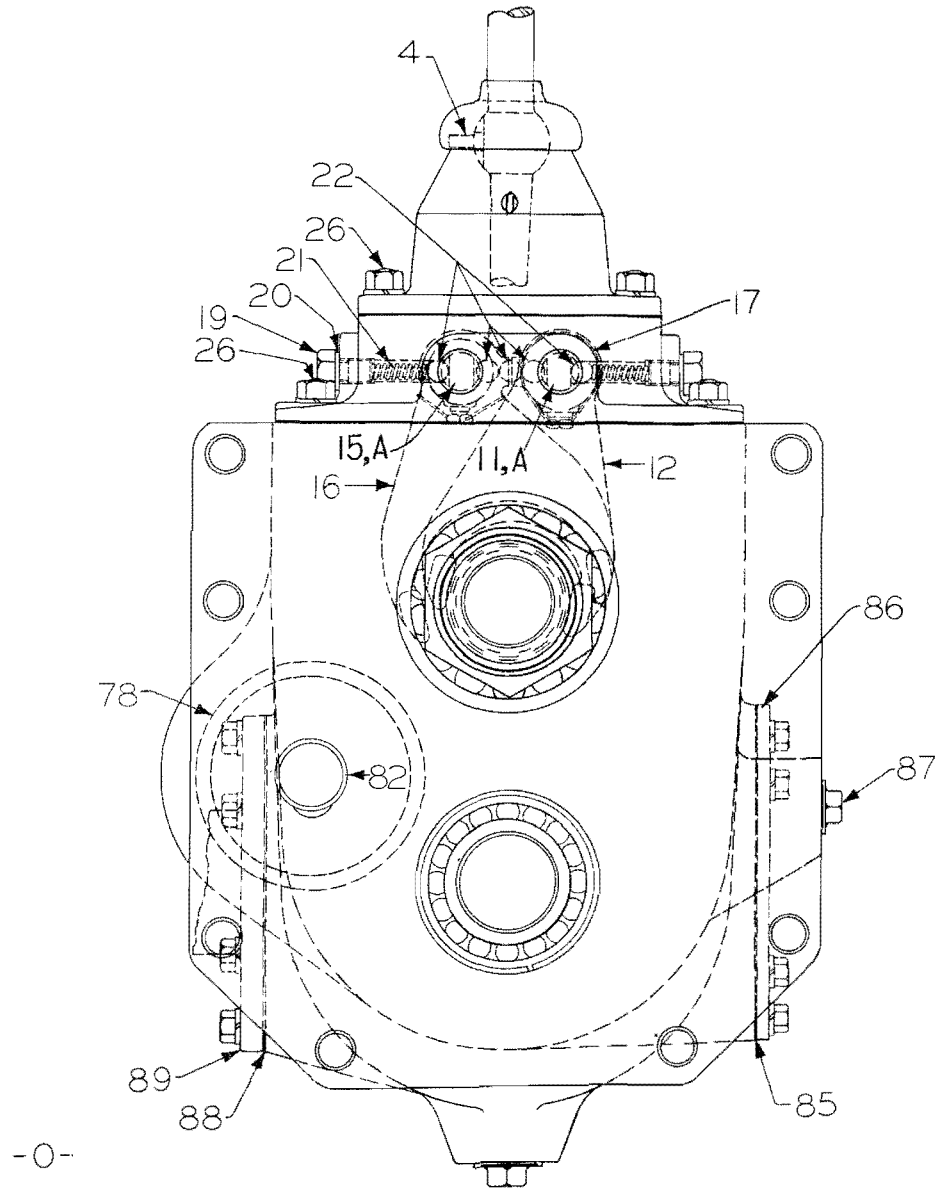

-0-

B/M PGU-1822
PGU-1823-A

Figure 19B. Transmission

Refer to Pages 30 and
31 for Part Numbers

(Refer to Figures 19A and 19B for Reference Numbers)

REF. NO.	PART NO.	QUANTITY	DESCRIPTION
0	PGU-1823-A	1	Transmission, complete (includes Ref. Nos. 10A to 88 inclusive except Ref. Nos. 11 and 15)
1	PGU-1822	1	Gear shift lever group (includes Ref. Nos. 2 to 8 inclusive)
2	PGF-9156	1	Gear shift lever
3	PGF-7721	1	Gear shift lever ball
4	PGF-9130	1	Shift lever lock pin
5	PGF-9157	1	Shift tower dust cover
6	PGF-9122	1	Shift lever spring seat
7	PGF-9123	1	Shift lever spring
8	PG-1738	1	Shift tower
9	PGU-1738-A	1	Transmission case cover group (includes Ref. Nos. 10A to 22 inclusive except Ref. Nos. 11 and 15)
10	PG-1737	1	* Cover (no longer furnished. Order Ref. Nos. 10A, 11A and 15A)
10A	PG-1868	1	% Cover
11	PGF-9129	1	2nd and 3rd shift rod (used with PG-1737 cover)
11A	PGF-10189	1	2nd and 3rd shift rod (used with PG-1868 cover)
12	PGF-9127	1	2nd and 3rd shift fork
13	PGF-9160	3	Shift fork locking screw
14	PGF-9738	3	Shift fork locking screw wire
15	PGF-9128	1	1st and reverse shift rod (used with PG-1737 cover)
15A	PGF-10188	1	1st and reverse shift rod (used with PG-1868 cover)
16	PGF-9126	1	1st and reverse shift fork
17	PGF-9159	1	2nd and 3rd shift lug
18	164032	3	Expansion plug (2 used with PG-1737 cover)
19	PGF-9132	2	Shift rod lock cap screw
20	PGF-5717	2	Shift rod lock cap screw washer
21	PGF-9131	2	Shift rod lock spring
22	O21003	5	Shift rod lock spring ball
23	PGF-9102	1	Shift tower gasket
24	PGF-10059	1	Oil guard
25	PGF-9112	1	Transmission cover gasket
26	PGF-8433	12	Stud
27	PGF-9133	1	Slotted nut
28	MUJCO-5116-J	1	Fitting yoke
29	PGF-3216	1	Oil seal
30	311167	1	Ball bearing
31	PG-1739	1	Bearing support housing
32	PGF-9091	6	Stud-housing to case
33	PGF-9125	1	Gasket
34	PGF-9066	1	Clutch shaft and drive pinion - 24 teeth
35	PGF-9082	1	Drive pinion bearing retainer nut
36	311596	1	Drive pinion bearing
37	318446	1	MS roller bearing

Note: * Last used on machine numbered H-1062.

% First used on machine numbered H-1064.

(Refer to Figures 19A and 19B for Reference Numbers)

REF. NO.	PART NO.	QUANTITY	DESCRIPTION
38	PGF-9068	1	MS 2nd and 3rd speed shifter clutch gear - 14 and 16 teeth
39	PGF-9070	1	MS 2nd speed gear - 30 teeth
40	PGF-9120	1	2nd speed gear snap ring
41	PGF-9063	1	2nd speed gear splined thrust washer
42	PGF-9084	42	2nd speed gear roller
43	PGF-9069	1	2nd speed gear bearing sleeve
44	PGF-9116	1	Bearing sleeve dowel pin
45	PGF-9115	1	2nd speed gear thrust washer
46	PGF-9072	1	MS 1st speed gear - 38 teeth
47	PGF-9084	42	MS 1st speed gear roller
48	PGF-9114	1	1st speed gear thrust washer
49	PGF-9074	1	MS 1st speed and reverse shifter clutch gear - 20 teeth
50	PGF-9076	1	MS reverse gear - 36 teeth
51	PGF-9119	1	MS reverse gear snap ring
52	PGF-9062	1	MS reverse gear splined thrust washer
53	PGF-9084	48	MS reverse gear roller
54	PGF-9075	1	MS reverse gear bearing sleeve
55	PGF-9134	1	MS bearing thrust washer
56	PGF-9158	1	MS bearing snap ring
57	311429	1	MS ball bearing
58	PGF-8446	1	MS bearing retainer nut
59	PGF-9065	1	Main shaft
60	PG-1736	1	CS bearing cap
61	BRF-1894	4	Stud-bearing cap to case
62	PGF-9110	1	CS bearing cap gasket
63	PGF-9083	1	CS bearing adjusting nut
64	311368	1	CS ball bearing with snap ring
65	PGF-9118	1	CS driven gear thrust washer
66	PGF-9067	1	CS driven gear - 42 teeth
67	PG-1732	1	Clutch brake drum
68	PGF-9071	1	CS 2nd speed gear - 36 teeth
69	PGF-9073	1	CS 1st speed gear - 28 teeth
70	PGF-9027	1	Tire pump drive gear - 21 teeth
71	PGF-9108	1	Tire pump gear spacer
72	PGF-9078	1	CS reverse gear - 27 teeth
73	PGF-9117	1	CS reverse gear snap ring
74	311322	1	CS ball bearing
75	ASF-3268	1	CS ball bearing snap ring
76	PGF-9064	1	Countershaft
77	PG-1731	1	Transmission case
78	PGF-9077	1	Reverse idler gear - 25 teeth
79	311447	1	Reverse idler gear bearing
80	PGF-9121	2	Reverse idler gear bearing snap ring
81	PGF-9107	2	Reverse idler gear bearing spacer
82	PGF-9109	1	Reverse idler shaft
83	111010	1	Reverse idler shaft key
84	PGF-9014	1	Drain plug
85	PGF-9103	1	PTO cover plate gasket
86	PGF-9106	1	PTO cover plate-tire pump
87	810004	1	Oil level and filler plug
88	PGF-9864	1	Clutch brake bracket gasket
89	PG-1688	1	Clutch brake bracket
90	PGF-8479	1	Transmission case gasket
91		1	Transfer case

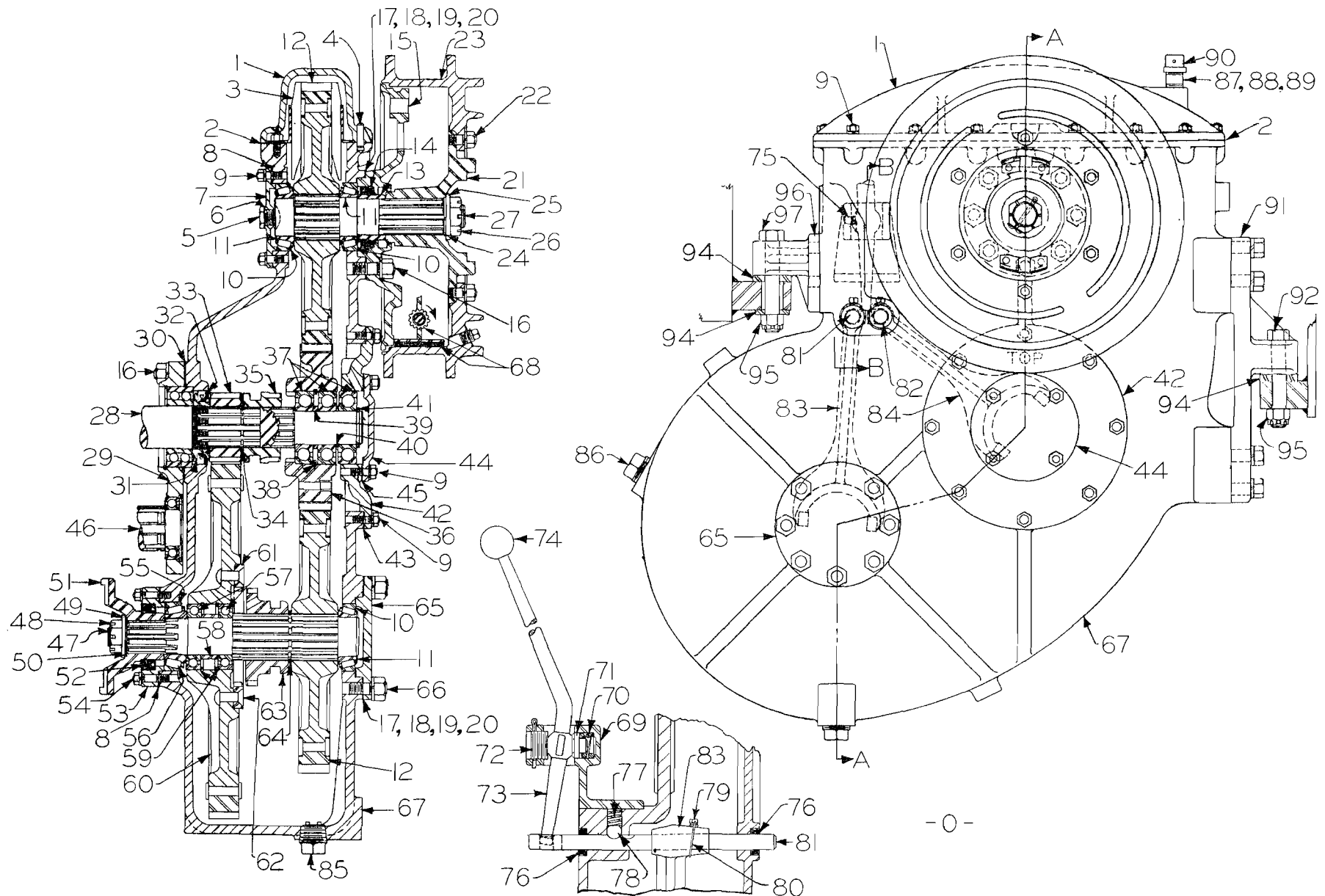

Section A-A

Section B-B

Refer to Pages 33 and 34 for Part Numbers

B/M PGU-1830

Figure 20. Transfer Case

REF. NO.	PART NO.	QUANTITY	DESCRIPTION
0		1	Transfer case group
1	PG-1637	1	Gear housing cover
2	PGF-8647	1	Cover gasket
3	PGF-8819	2	Oil collector
4	PGF-8815	2	Dowel pin
5	PGF-3849	1	Plug (not required when Odometer is used)
6	PGF-4217	1	Gasket
7	PG-1590	1	Bearing cap
8	PGF-8450	2	Gasket
9	PGF-8433	30	Stud
10	313322	3	Bearing cup
11	312743	3	Bearing cone and rollers
12	PGF-8642	2	Gear - 71 teeth
13	PGF-8806	1	Spacer
14	PGF-8809	1	Oil seal
15	PG-1682	1	Backing plate
16	PGF-8498	15	Stud
17	PGF-8824	As req'd.	Shim - .020" thick
18	PGF-8825	As req'd.	Shim - .007" thick
19	PGF-8826	As req'd.	Shim - .005" thick
20	PGF-8827	4	Gasket (paper)
21	MUJCO-7169-J	1	Brake flange
22	PGF-8855	6	Stud
23	PG-1683	1	Brake drum
24	PGF-8521	2	Gasket
25	PGF-8706	1	Washer
26	PGF-8708	1	Nut
27	PGF-8805	1	Driven shaft-upper
28		1	Transmission main shaft
29		1	Transmission case
30		1	Transmission case gasket
31	PGF-8446	1	Bearing retainer nut
32	PGF-8447	1	Oil seal
33	PGF-8644	1	Drive pinion - 17 teeth
34	PGF-8435	1	Snap ring
35	PGF-8426	1	Shifter clutch gear - 21 teeth
36	PGF-8643	1	Idler gear - 42 teeth
37	311367	3	Ball bearing
38	PGF-8439	1	Snap ring
39	PGF-8428	1	Bearing spacer
40	PGF-8429	1	Bearing spacer washer
41	PGF-8436	1	Snap ring
42	PG-1636	1	Bearing support
43	PGF-8821	1	Gasket
44	PG-1692	1	Bearing cap
45	PGF-8837	1	Gasket
46		1	Transm. countershaft-see transmission page
47	PGF-8814	1	Driven shaft-lower
48	PGF-4667	1	Slotted nut
49	PGF-4864	1	Washer
50	PGF-4865	2	Gasket
51	MUJCO-6080-J	1	Fitting yoke
52	PGF-6024	1	Oil seal
53	PG-1607	1	Bearing cap
54	PGF-8431	4	Stud
55	313190	1	Bearing cup
56	312514	1	Bearing cone and rollers
57	311322	2	Ball bearing
58	PGF-8445	1	Bearing spacer
59	PGF-8438	2	Snap ring
60	PGF-8709	1	Gear - 97 teeth
61	PGF-8440-2	1	Drive ring - 30 teeth
62	575143	6	Rivet-countersunk head
63	PGF-8434	1	Shifter clutch gear - 30 teeth
64	PGF-8437	1	Snap ring

(continued)

(Refer to Figure 20 for Reference Numbers)

REF. NO.	PART NO.	QUANTITY	DESCRIPTION
65	PG-1680	1	Bearing cap
66	PGF-8851	7	Stud
67	PG-1681	1	Gear housing
68	PGF-8968	1	Propeller shaft brake group
69	PG-1803	1	Shift lever support
70	TF-1414	1	Spring
71	PGF-8489	1	Spring seat
72	PGF-8816	1	Plug
73	PGF-9610	1	Shift lever
74	PGF-7721	1	Shift lever ball
75	PGF-9259	1	Shift lever pin
76	PGF-8486	4	Oil seal
77	PGF-309	2	Spring
78	PGF-8638	2	Ball
79	PGF-9160	2	Lock screw
80	PGF-9738	2	Lock wire
81	PGF-8818	1	Shift rod-low range
82	PGF-8817	1	Shift rod-high range
83	PGF-8885	1	Shift fork-low range
84	PGF-8900	1	Shift fork-high range
85	PGF-9014	1	Drain plug
86	810005	1	Oil level and filler plug
87	PGU-1741-A	1	Breather group (includes Ref. Nos. 88, 89 and 90)
88	PGF-9974	1	Tube with pin
89	PGF-10037	1	Element
90	PGF-5166	1	Cap
91	PG-1677	1	Support-left hand
92	PGF-8882	1	Support bolt
94	PGF-8867	3	Washer
95	727009	2	Castellated nut
96	PG-1678	1	Support-right hand
97	PGF-8884	1	Support bolt

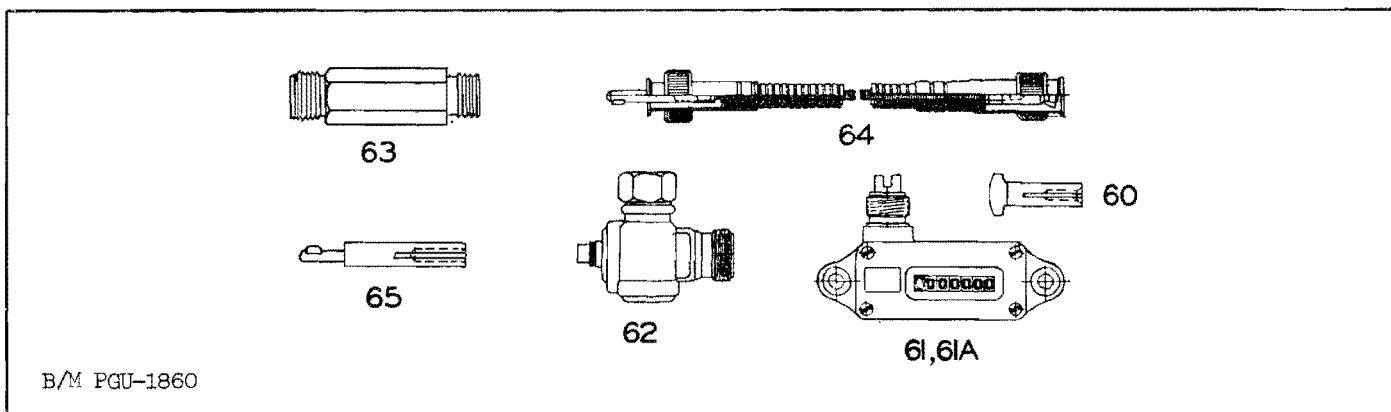

Figure 21. Odometer

REF. NO.	PART NO.	QUANTITY	DESCRIPTION
60	PGF-3850	1	Drive tip
61	PGF-9361	1	Odometer-mile reading
61A	PGF-9831	1	Odometer-kilometer reading (special order)
62	PGF-9363	1	Right angle joint (.266 ratio)
63	PGF-9889	1	Extension sleeve
64	PGF-9364	1	Flexible shaft
65	PGF-9888	1	Shaft extension

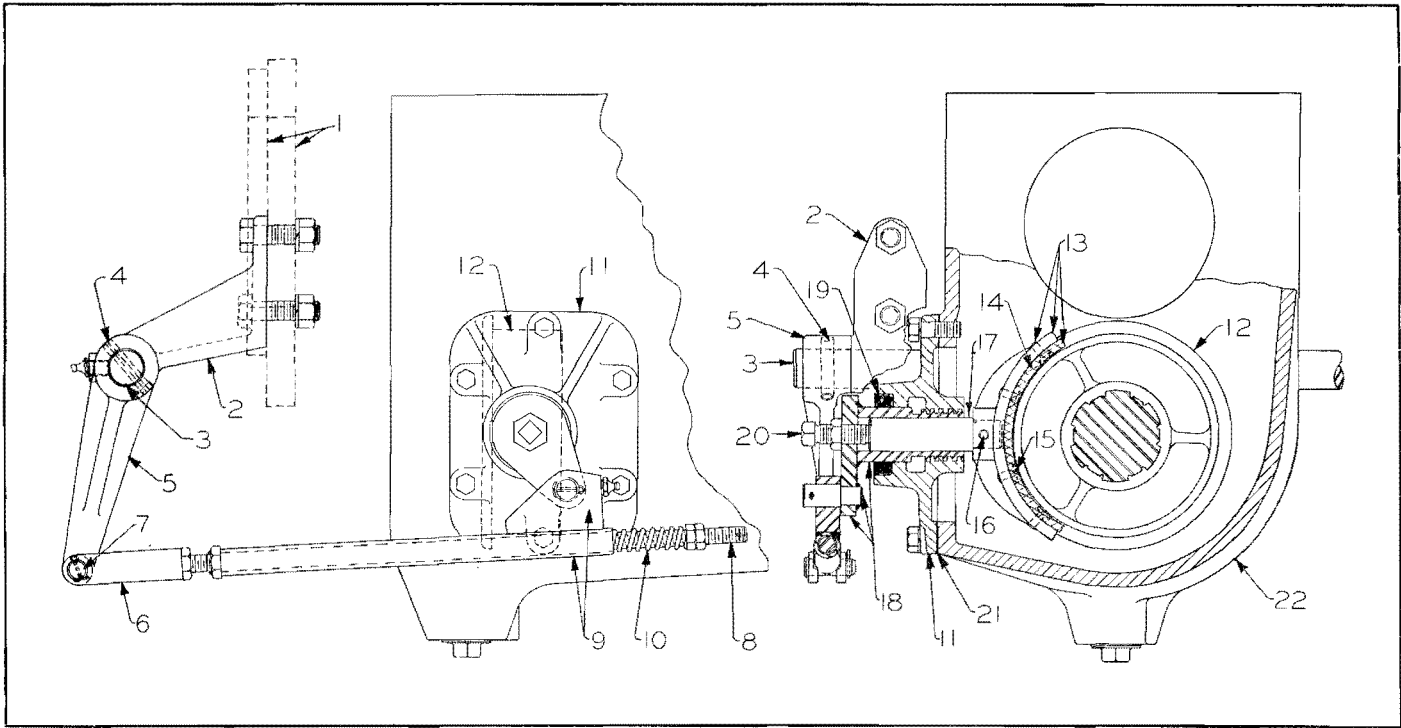

Figure 22. Clutch Brake

REF. NO.	PART NO.	QUANTITY	DESCRIPTION
1		1	Transmission support
2	PG-1769	1	Cross rod hanger
3	PGF-9260	1	Cross rod
4	PGF-9264	1	Pin
5	PG-1768	1	Lever
6	782005	1	Rod end fork
7	783005	1	Pin
8	PGF-8895	1	Pull rod
9	PGF-8970	1	Tube
10	PGF-7610	1	Spring
11	PG-1688	1	Bracket
12	PG-1732	1	Brake drum
13	PGX-1414	1	Shoe with lining and rivets (includes Ref. Nos. 14 and 15)
14	PGF-7590	1	Lining
15	713128	6	Tubular rivet
16	BDF-345	1	Pin
17	PGF-8828	1	Shaft
18	PGF-8972	1	Screw assembly
19	PGF-8857	1	Oil seal
20	755095	1	Set screw-cup point
21	PGF-9864	1	Gasket
22		1	Transmission

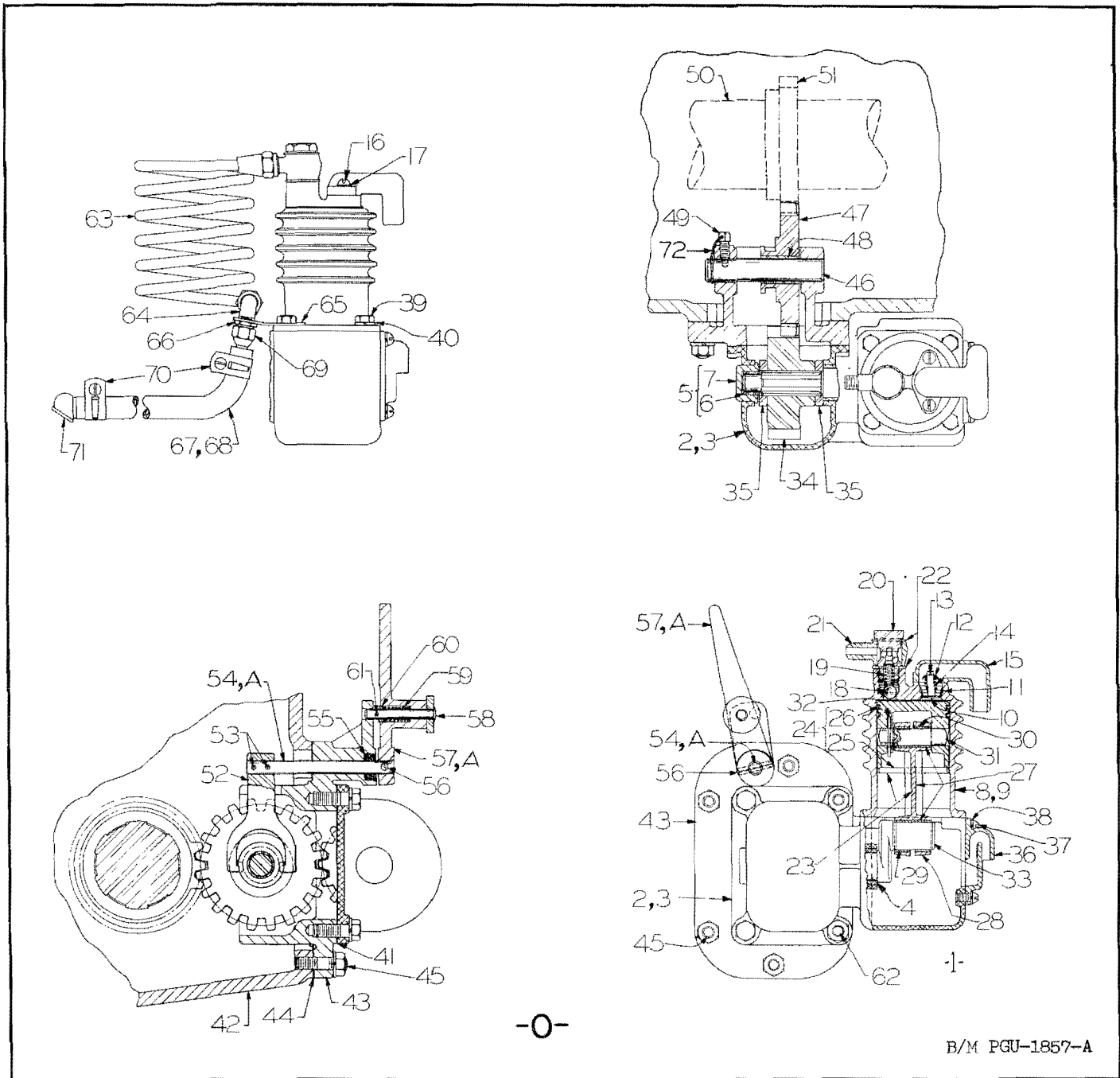

Figure 23. Tire Pump

REF. NO.	PART NO.	QUANTITY	DESCRIPTION
0	PGU-1857-A	1	Tire pump group
1	PGF-9111	1	Compressor complete (incl. Ref. 2 to 41 inclusive)
2	SBCO-596-F	1	Housing and bushing group (includes Ref. Nos. 3,4,6 and 7)
3	SBCO-562-F	1	Housing
4	SBCO-585-F	1	Crank bushing-large
5	SBCO-689-F	1	Crank bushing group-small (incl. Ref. 6 and 7)
6	SBCO-690-F	1	Crank bushing
7	SBCO-681-F	1	Crank bushing plug
8	SBCO-1001-F	1	Cylinder and valve group (includes Ref. Nos. 9 to 22 inclusive)
9	SBCO-1002-F	1	Cylinder
10	SBCO-304-A	1	Intake valve
11	SBCO-400-F	1	Intake valve guide

REF. NO.	PART NO.	QUANTITY	DESCRIPTION
12	SBCO-114-A	1	Intake valve washer
13	SBCO-1150-F	1	Intake valve spring retaining pin
14	SBCO-401-F	1	Intake valve spring
15	SBCO-1000-F	1	Intake valve cover
16	SBCO-137-E	2	Intake valve cover screw
17	SBCO-158-E	2	Intake valve cover screw lock washer
18	SBCO-112-A	1	Outlet valve
19	SBCO-316-A	1	Outlet valve spring
20	SBCO-156-E	1	Outlet valve spring retainer
21	SBCO-979-F	1	Outlet valve outlet
22	SBCO-314-A	2	Outlet valve gasket
23	SBCO-220-F	1	Piston and connecting rod group (incl. Ref. Nos. 25,26 and 28 to 32 inclusive)
24	SBCO-716-F	1	Piston and ring group (incl. Ref. Nos. 25 & 26)
25	SBCO-203-F	1	Piston
26	SBCO-273-A	6	Piston ring
27	SBCO-865-F	1	Connecting rod and bushing group (includes Ref. Nos. 28,29 and 30)
28	SBCO-863-F	1	Connecting rod
29	SBCO-866-F	1	Connecting rod bushing
30	SBCO-864-F	1	Piston pin bushing
31	SBCO-237-E	1	Piston pin
32	SBCO-281-A	1	Piston pin cotter pin
33	SBCO-240-F	1	Crank
34	SBCO-822-F	1	Crank gear
35	SBCO-848-F	2	Crank gear spacer
36	SBCO-966-F	1	Breather cover
37	SBCO-967-F	3	Breather cover screw
38	SBCO-1019-F	3	Breather cover screw lock washer
39	SBCO-318-A	4	Cylinder to housing screw
40	SBCO-110-F	4	Cylinder to housing screw lock washer
41	SBCO-566-F	1	Housing to adapter gasket
42		1	Transmission (see transmission page)
43	PG-1734	1	Adapter
44	PGF-9103	1	Adapter gasket
45	PGF-9096	4	Stud-adapter to case
46	PGF-9092	1	Sliding gear shaft
47	PGF-9081	1	Sliding gear - 20 teeth
48	PGF-10753	1	Sliding gear bushing
49	PGF-9099	1	Lock screw
50		1	Transm. countershaft (see transmission page)
51		1	Transm. tire pump gear (see transmission page)
52	PGF-9097	1	Shift fork
53	PGF-9105	2	Shift fork pin
54	PGF-9098	1	* Shift rod
54A	PGF-10088	1	Shift rod
55	PGF-8940	1	Oil seal
56	PGF-9104	1	Handle pin
57	PG-1735	1	* Shift handle
57A	PG-1864	1	Shift handle
58	PGF-9101	1	Handle lock pin
59	CAF-998	1	Handle lock spring
60	PGF-9094	1	Handle lock pin washer
61	739187	1	Groove pin
62	PGF-9095	2	Stud-compressor to case
63	PGF-7646	1	Compressor air tube
64	835001	1	Elbow
65	PGF-9885	1	Tube clip
66	526001	1	Reducer bushing
67	PGF-9378	1	Air hose group (incl. Ref. Nos. 68 to 71 inclusive)
68	PGF-9080	1	Air hose
69	PGF-9962	1	Female swivel coupling
70	034103	2	Hose clamp
71	PGF-9365	1	Air chuck
72	PGF-10214	1	Lock wire

Note: * Last used on machine numbered H-764. No longer furnished. Order PGF-10088 and PG-1864.

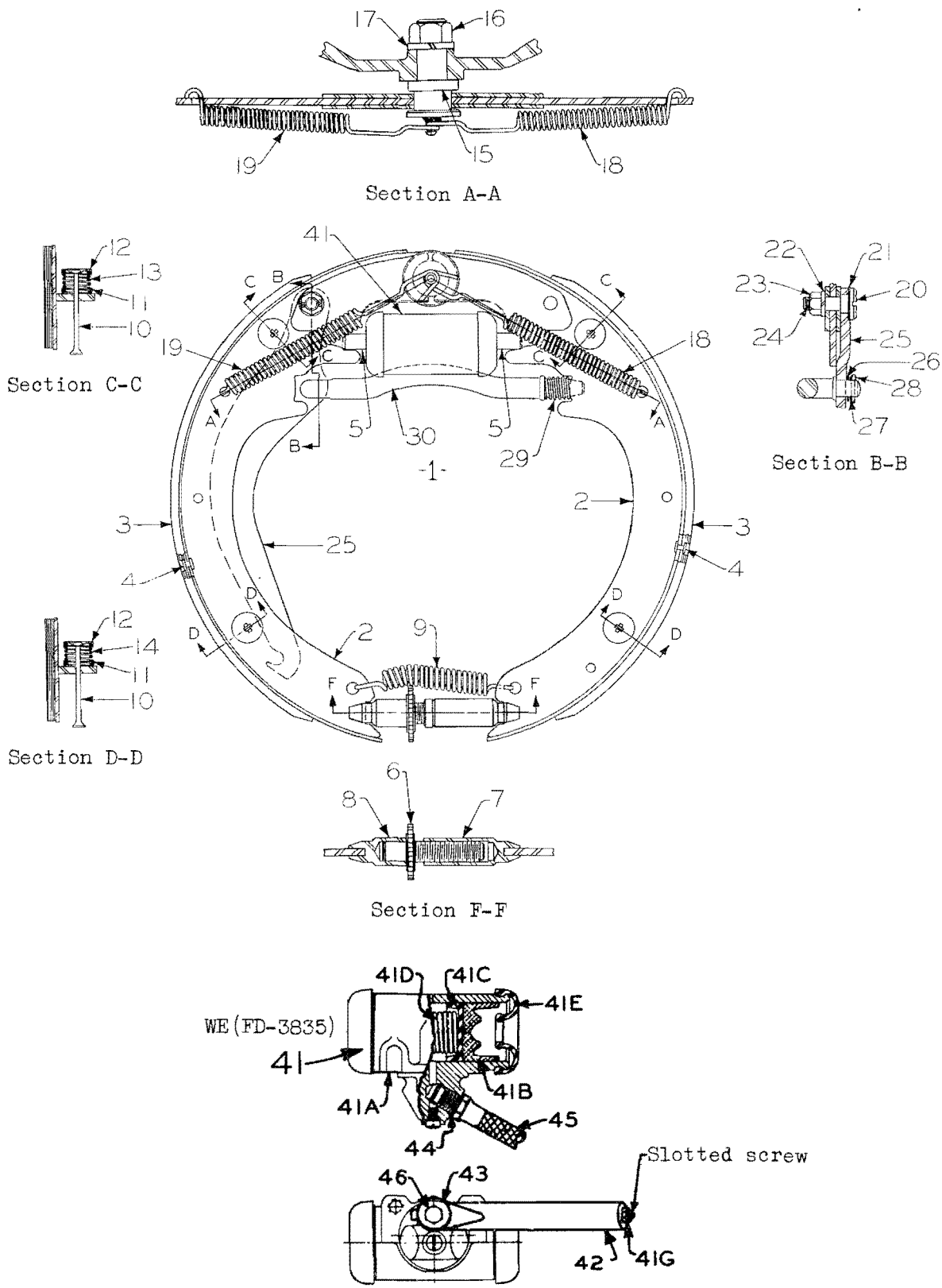

Figure 24. Propeller Shaft Brake

B/M PGU-1841

REF. NO.	PART NO.	QUANTITY	DESCRIPTION
1	PGF-8968	1	Brake group (includes Ref. Nos. 2 to 29 inclusive)
2	PGF-8968-55	1 PK.	2 shoes with linings, rivets and links (includes Ref. Nos. 3,4 and 5)
3	PGF-8968-56	1 PK.	2 linings with rivets (includes Ref. No. 4)
4	BPCO-70-S-4	44	Tubular rivet
5		2	* Connecting link
6	BPCO-34121	1	Adjusting screw
7	BPCO-48205	1	Adjusting screw pivot nut
8	BPCO-48207	1	Adjusting screw socket
9	BPCO-26114	1	Adjusting screw spring
10	BPCO-25831	4	Spring pin
11	BPCO-24028	4	Centralizing cup
12	BPCO-23969	4	Spring cup
13	BPCO-28354	2	Shoe hold down spring
14	BPCO-24784	2	Shoe hold down spring
15	BPCO-48202	1	Anchor pin and shoe guide
16	BPCO-46770	1	Anchor pin nut
17	BPCO-24959	1	Anchor pin lock washer
18	BPCO-32934	1	Anchor to shoe spring
19	BPCO-37092	1	Anchor to shoe spring
20	BPCO-35424	1	Shoe and lever pin
21	BPCO-36170	1	Lever pin washer
22	BPCO-901008	1	Lever pin lock washer
23	BPCO-901626-K6	1	Lever pin nut
24	BPCO-901220	1	Cotter pin
25	BPCO-45629	1	Lever
26	BPCO-30152	1	Strut to lever spring
27	BPCO-48098	1	Washer
28	BPCO-901221	1	Cotter pin
29	BPCO-25539	1	Strut spring
30	ASF-5057	1	Strut

Note: * Indicates part not sold separately. Order Ref. No. 2.

Propeller Shaft Brake Cylinder

41	PGF-7413	1	Drum cylinder group (includes Ref. Nos. 41A to 41E inclusive)
41A	WE-FC-4976	1	Casting
41B	WE-FC-665	2	Piston
41C	WE-FC-666	2	Cup
41D	WE-FC-668	1	Return spring
41E	WE-FC-4109	2	Boot
41G	WE-FC-2933	1	Bleeder valve extension screw
42	PG-970	1	Bleeder valve extension
43	PGF-4442	2	Bleeder valve extension washer
44	ASF-5451	1	Washer
45	PGF-9018	1	Hose
46	PGF-4440	1	Bleeder screw

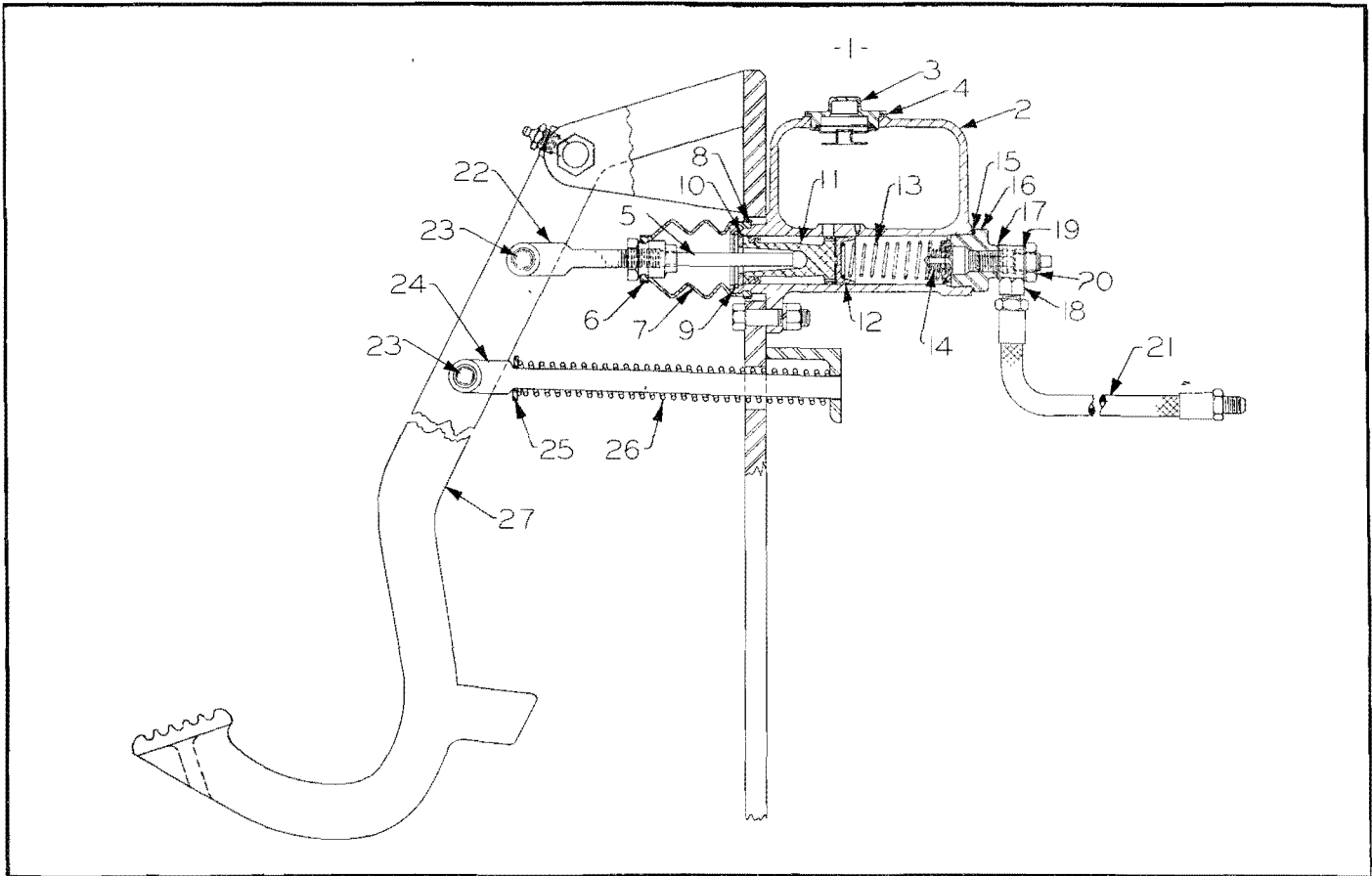

Figure 25. Foot Brake Mechanism

REF. NO.	PART NO.	QUANTITY	DESCRIPTION
1	PGF-9297	1	Master cylinder group (includes Ref. Nos. 2 to 20 inclusive)
2	WE-FD-4887	1	Supply tank
3	WE-FC-6018	1	Filler plug
4	WE-FC-6019	1	Filler plug gasket
5	WE-FC-2928	1	Piston link
6	WE-FC-939	1	Boot strap-small
7	WE-FC-2930	1	Boot
8	WE-FC-2931	1	Boot strap-large
9	WE-FC-3709	1	Piston stop wire
10	WE-FC-3710	1	Piston stop washer
11	WE-FC-3707	1	Piston group
12	WE-FD-2398	1	Cup
13	WE-FC-3572	1	Return spring
14	WE-FC-3578	1	Check valve group
15	WE-FC-3587	1	Head gasket
16	WE-FC-3861	1	Head
17	WE-FC-602	1	Gasket
18	WE-FC-6720	1	Outlet connection
19	WE-FC-603	1	Gasket
20	WE-FC-3474	1	Fitting bolt
21	PGF-9018	1	Hose
22	PGF-9766	1	Yoke
23	783005	1	Pin
24	PGF-9767	1	Rod
25	765006	1	Washer
26	MSF-853	1	Spring
27	PG-1828	1	Pedal

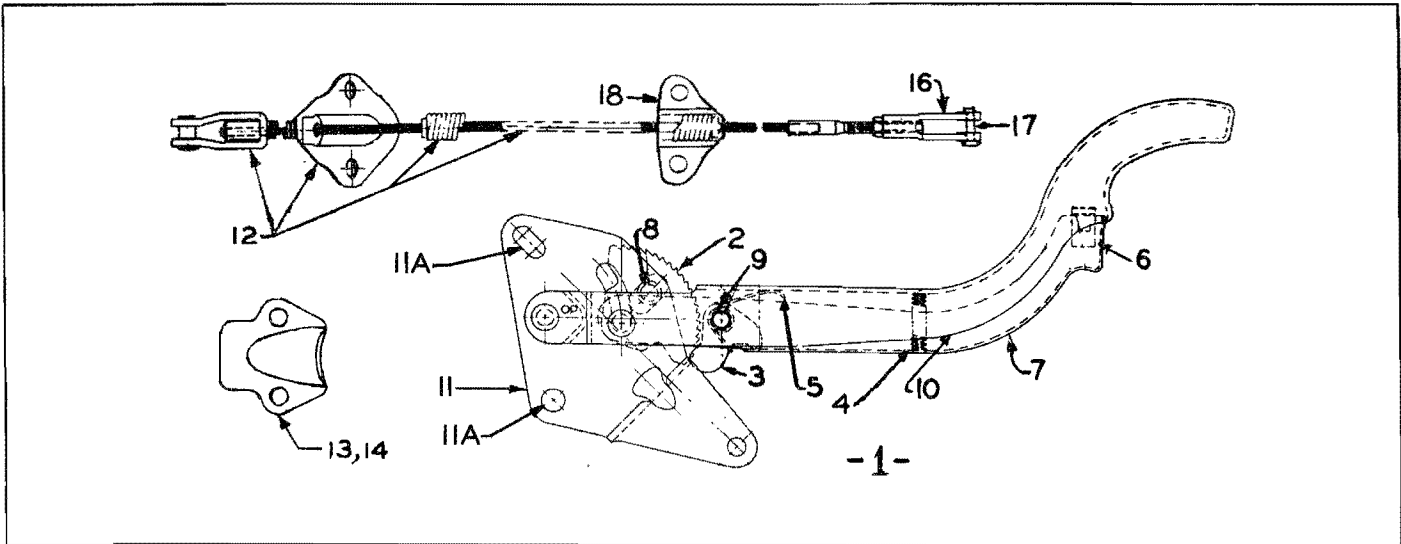
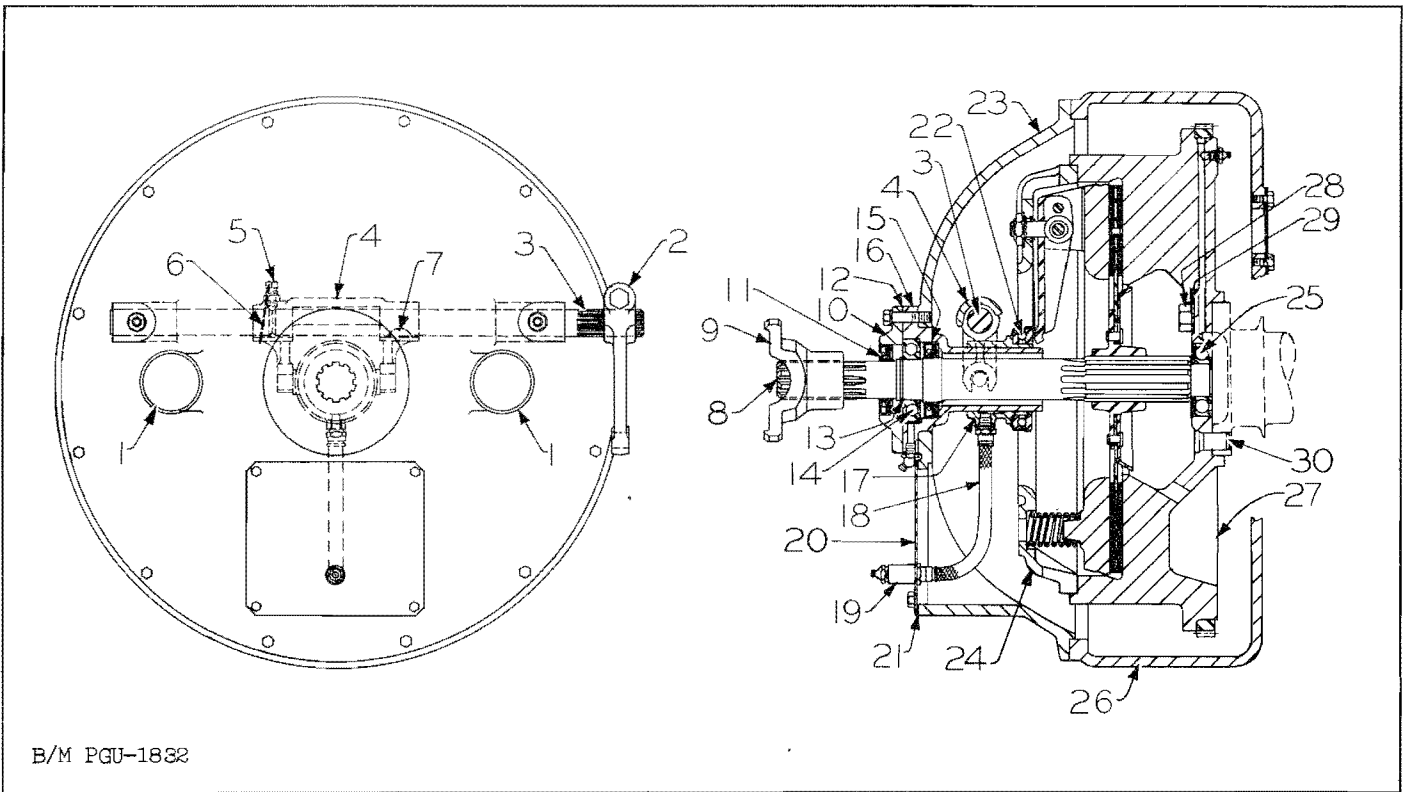

Figure 26. Hand Brake Mechanism

REF. NO.	PART NO.	QUANTITY	DESCRIPTION
1	PGF-6462	1	Brake lever group (includes Ref. Nos. 2 to 11 inclusive)
2	OPD-606868	1	Sector
3	OPD-610588	1	Pawl
4	OPD-606887	1	Latch spring
5	OPD-606834	1	Pawl spring
6	OPD-606851	1	Rubber bumper
7	OPD-611743	1	Latch
8	OPD-606680	1	Sector guide pin
9	OPD-610585	1	Sleeve
10	OPD-611190	1	Lever shaft
11	OPD-610533	1	Mounting bracket
11A	PGF-5982	2	Spacer
12	PGF-8971	1	Cable and conduit group
13	BPCO-29251	1	Bracket cap
14	BPCO-29258	1	Bracket seal
16	PGF-6791	1	Rod end fork
17	RGF-1332	1	Fork pin
18	PGF-8979	1	Conduit bracket



B/M PGU-1832

Figure 27. Clutch and Shaft Assembly for UD-14A Engine

REF. NO.	PART NO.	QUANTITY	DESCRIPTION
1	BTF-872	2	Breather
2	PGF-8978	1	Clutch release lever
3	PGF-8760	1	Clutch yoke shaft
4	PG-1667	1	Clutch throwout yoke
5	PGF-9269	1	Clutch yoke lock screw
6	PGF-9738	1	Locking wire
7	111010	1	Woodruff key
8	PGF-9629	1	Clutch shaft
9	MUJCO-5116-J	1	Fitting yoke
10	PG-1670	1	Bearing cap
11	PGF-8839	1	Oil seal
12	PGF-8766	1	Gasket
13	PGF-8862	1	Snap ring
14	311167	1	Ball bearing
15	PGF-8840	1	Oil seal
16	PG-1686	1	Bearing carrier sleeve
17	PG-1668	1	Bearing carrier
18	PGF-4477	1	Grease hose
19	525001	1	Coupling
20	PGF-8762	1	Inspection plate
21	PGF-8763	1	Gasket
22	PGF-8831	1	Clutch throwout bearing
23	PG-1661	1	Clutch bell housing
24		1	Clutch (see other pages)
25	311243	1	Pilot bearing
26	IHC-252474R11	1	Flywheel housing (per GPS-201)
27	IHC-252459R11	1	Flywheel, complete (per GPS-201)
28	IHC-32333-D	6	Flywheel bolt
29	IHC-24943-D	3	Flywheel bolt lock plate
30	IHC-32332-D	2	Flywheel dowel pin

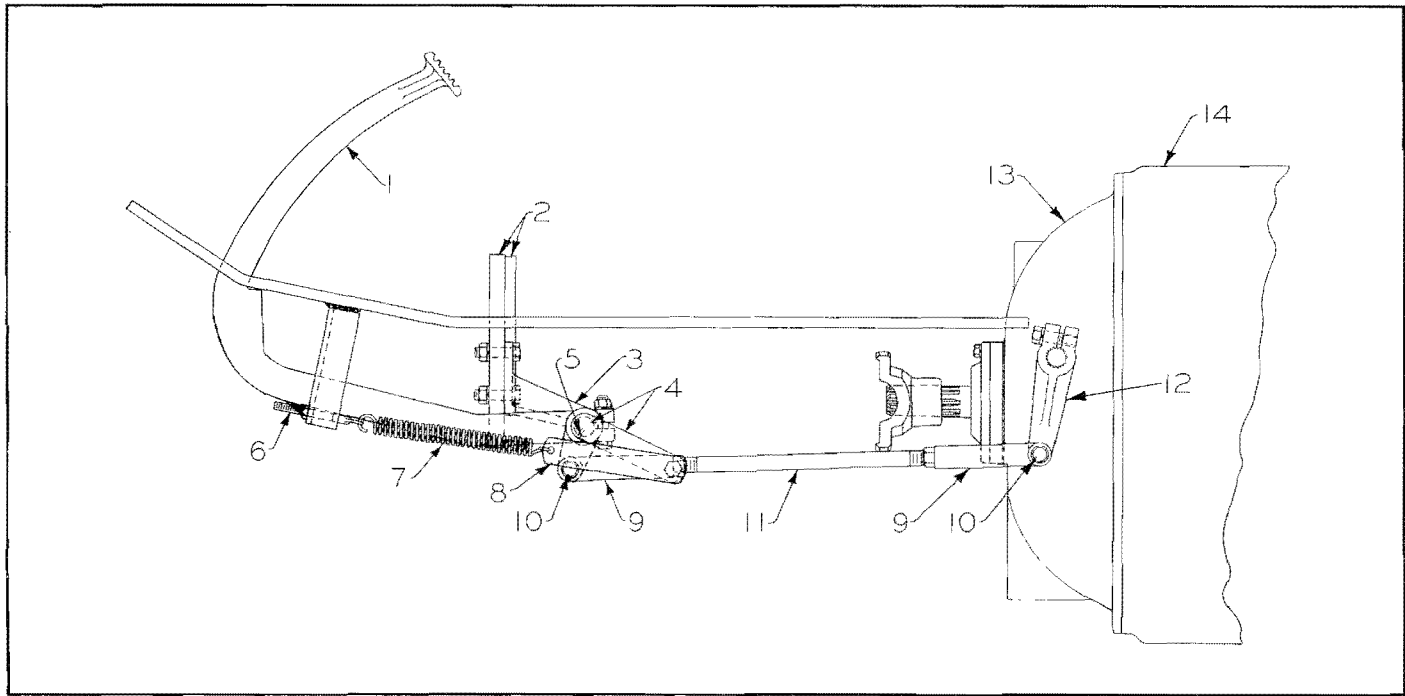
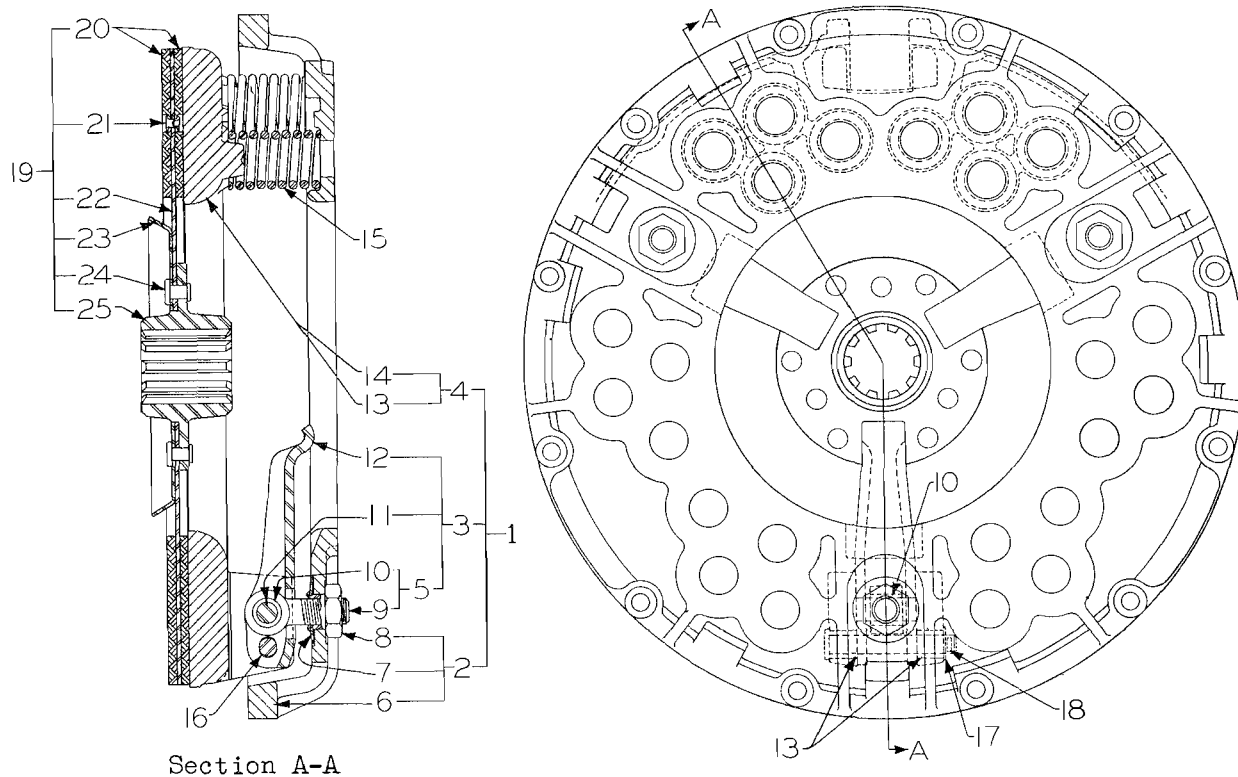

Figure 28. Clutch Operating Mechanism **for UD-14A Engine**

REF. NO.	PART NO.	QUANTITY	DESCRIPTION
1	PG-1763	1	Pedal
2	PGF-9772	1	Transmission support
3	PG-1769	1	Cross rod hanger
4	PGF-9260	1	Cross rod
5	111012	1	Woodruff key
6	PGF-7737	1	Spring eyebolt
7	MGF-2703	1	Spring
8	PGF-8977	1	Link
9	782010	2	Rod end fork
10	783007	2	Pin
11	PGF-8992	1	Rod
12		1	Clutch release lever
13		1	Clutch bell housing
14		1	Flywheel housing



-0-

IMPORTANT NOTICE: Do not "over grease" clutch pilot bearing so that grease gets onto facings, Ref. 20. More clutch slippage and replacement is caused by grease getting on the facings than by any other single cause. Warped and cracked pressure plates, also worn facings are the result. They will not be replaced free at any time if over greased.

NOTE: THIS TYPE USES CAST BACK PLATE, REF. NO. 6.

Figure 29. Clutch (1st type)
for UD-14A Engine

REF. NO.	PART NO.	QUANTITY	DESCRIPTION
0	PGF-9631	1	Clutch group, complete (order PGF-10202)
1	RD-UCLA-1-7004	1	Cover group (includes Ref. Nos. 6 to 18 inclusive)
2	RD-UCL-7004	1	Back plate group (includes Ref. Nos. 6,7 and 8)
3	RD-UCL-6664	3	Lever group (includes Ref. Nos. 9,10,11 and 12)
4	RD-UCL-7005	1	Pressure plate group (includes Ref. Nos. 13 and 14)
5	RD-UCL-6295	3	Eyebolt group (includes Ref. Nos. 9 and 10)
6		1	* Back plate
7	RD-CL-6824	3	Adjusting nut washer
8	RD-CL-6825	3	Adjusting nut
9		3	@ Eyebolt
10	RD-CL-7080	3	Needle bearing
11	RD-CL-6280	3	Pivot pin
12	RD-CL-6664	3	Lever
13	RD-CL-7079	6	Needle bearing
14		1	% Pressure plate
15	RD-CL-6615-6	24	Pressure spring
16	RD-CL-6283	3	Lever pin
17	RD-CL-6284	3	Washer
18	RD-CL-4597	3	Cotter pin
19	RD-UCL-4-4541	1	Driven member group (includes 20 to 25 inclusive)
20	RD-CL-7563	2	Facing
21	RD-CL-1011-2	30	Tubular rivet
22		1	£ Clutch plate
23		1	£ Oil slinger
24		12	£ Rivet
25		1	£ Splined center

Note: * Indicates parts not sold separately. Order Ref. No. 2.
 @ Indicates parts not sold separately. Order Ref. No. 5.
 % Indicates parts not sold separately. Order Ref. No. 4.
 £ Indicates parts not sold separately. Order Ref. No. 19.

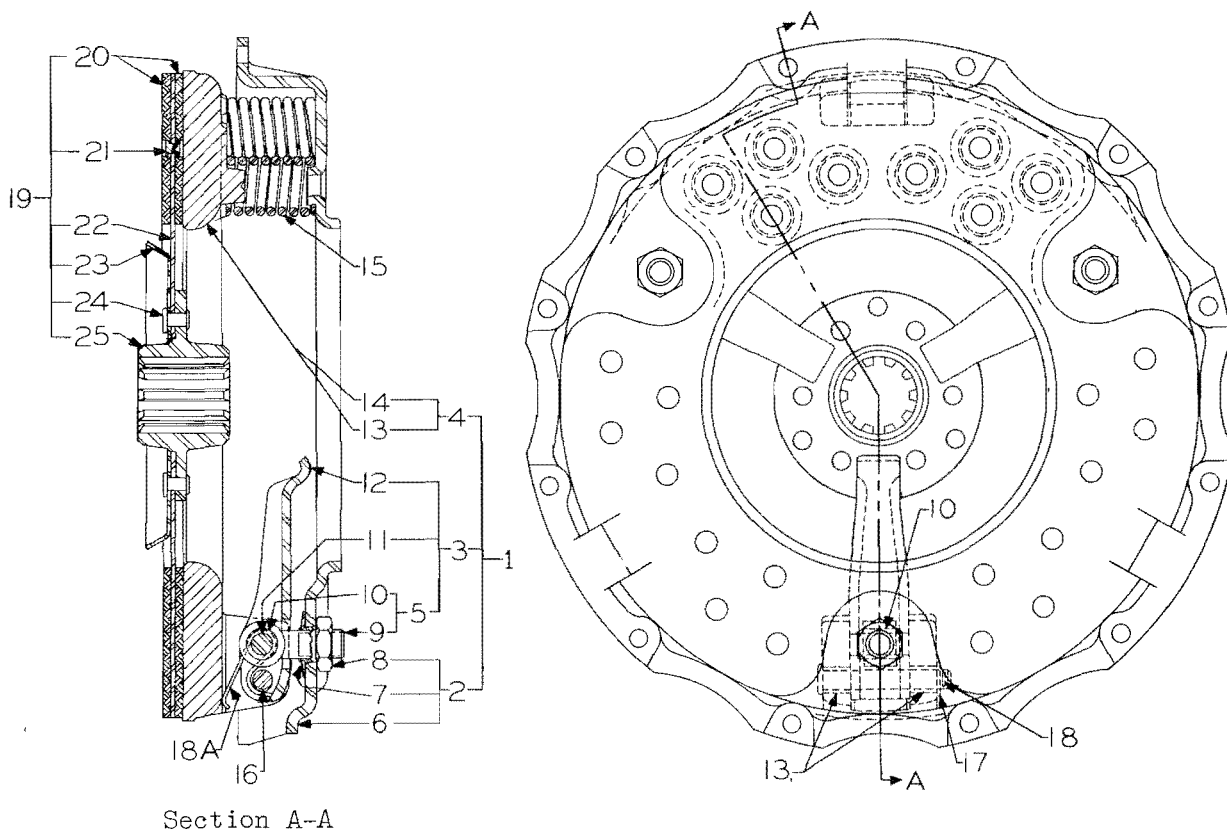

-0-

IMPORTANT NOTICE: Do not "over grease" clutch pilot bearing so that grease gets onto facings, Ref. 20. More clutch slippage and replacement is caused by grease getting on the facings than by any other single cause. Warped and cracked pressure plates, also worn facings are the result. They will not be replaced free at any time if over greased.

NOTE: THIS TYPE USES PRESSED STEEL BACK PLATE, REF. NO. 6.

Figure 29A. Clutch (2nd type)
for UD-14A Engine

REF. NO.	PART NO.	QUANTITY	DESCRIPTION
0	PGF-10202	1	Clutch group, complete
1	RD-UCLA-7-7386	1	Cover group (includes Ref. Nos. 6 to 18A inclusive)
2	RD-UCL-7386	1	Back plate group (includes Ref. Nos. 6,7 and 8)
3	RD-UCL-6664	3	Lever group (includes Ref. Nos. 9,10,11 and 12)
4	RD-UCL-7387	1	Pressure plate group (includes Ref. Nos. 13 and 14)
5	RD-UCL-6295	3	Eyebolt group (includes Ref. Nos. 9 and 10)
6		1	* Back plate
7	RD-CL-6824	3	Adjusting nut washer
8	RD-CL-6825-1	3	Adjusting nut
9		3	@ Eyebolt
10	RD-CL-7080	3	Needle bearing
11	RD-CL-6280	3	Pivot pin
12	RD-CL-6664	3	Lever
13	RD-CL-7079	6	Needle bearing
14		1	% Pressure plate
15	RD-CL-6615-6	24	Pressure spring
16	RD-CL-6283	3	Lever pin
17	RD-CL-6284	3	Washer
18	RD-CL-7575	3	Cotter pin
18A	RD-CL-7888	3	Anti-rattle spring
19	RD-UCL-4-4541	1	Driven member group (includes 20 to 25 inclusive)
20	RD-CL-7563	2	Facing
21	RD-CL-1011-2	30	Tubular rivet
22		1	£ Clutch plate
23		1	£ Oil slinger
24		12	£ Rivet
25		1	£ Splined center

Note: * Indicates parts not sold separately. Order Ref. No. 2.
 @ Indicates parts not sold separately. Order Ref. No. 5.
 % Indicates parts not sold separately. Order Ref. No. 4.
 £ Indicates parts not sold separately. Order Ref. No. 19.

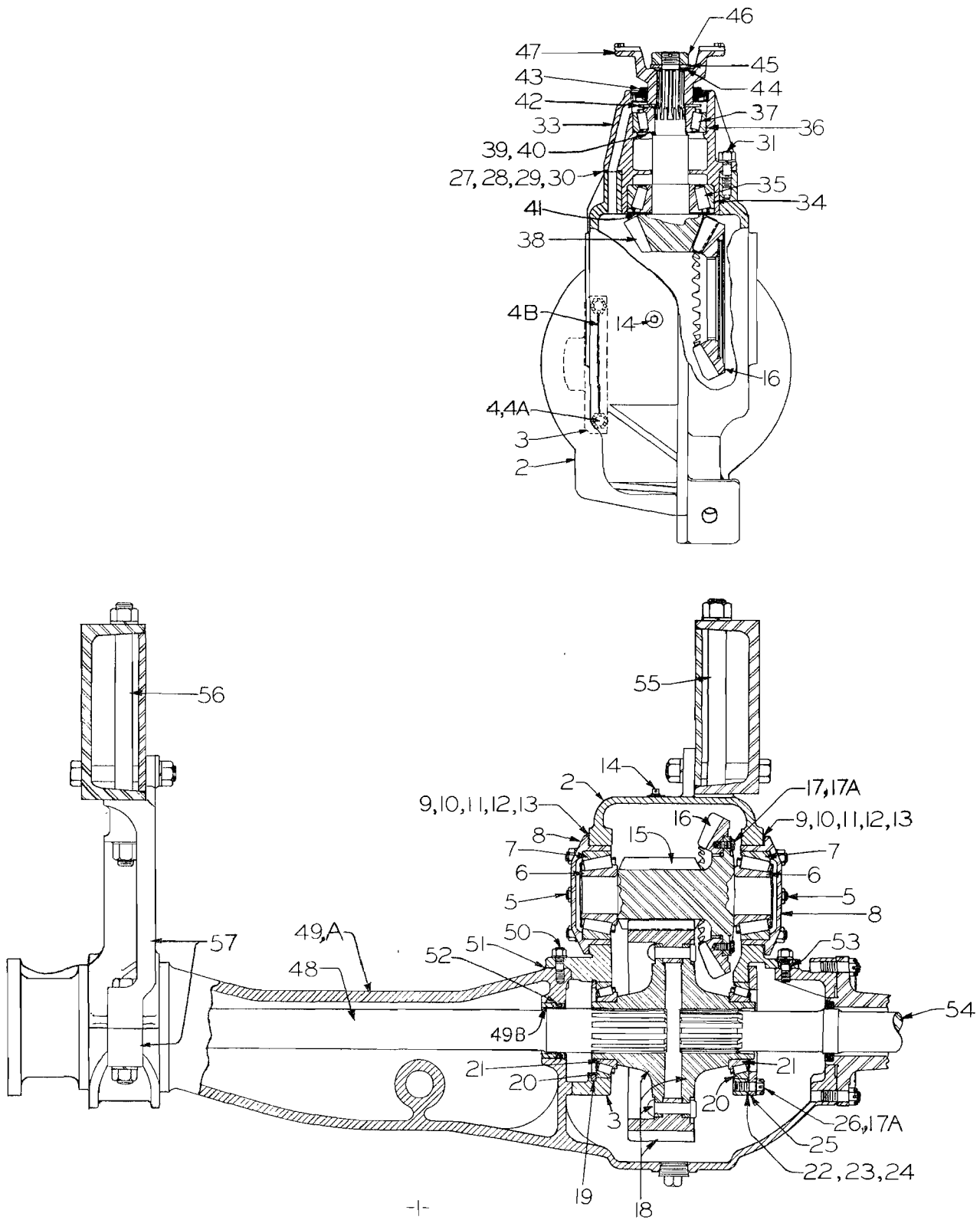

B/M PGU-1851

Figure 30. Rear Axle Gear and Pinion Carrier

REF. NO.	PART NO.	QUANTITY	DESCRIPTION
1	PGU-1851	1	Rear axle gear carrier group (includes Ref. Nos. 2 to 47 inclusive)
2	PGU-1652	1	Gear carrier casting (includes Ref. Nos. 3 to 5 inclusive)
3		1	@ Bearing cap
4	PGF-3087	2	Bearing cap stud
4A	727007	2	Castellated nut
4B	PGF-9486	1	Locking wire
5	BTF-890	12	Stud
6	312547	2	Bearing cone and rollers
7	313208	2	Bearing cup
8	BTX-59	2	Bearing cap with cup (includes 1 of Ref. No. 7)
9	BTF-721	As req'd.	Shim - .005" thick
10	BTF-722	As req'd.	Shim - .010" thick
11	BTF-723	As req'd.	Shim - .030" thick
12	BTF-724	As req'd.	Shim - .003" thick
13	BTF-725	2	Gasket (paper)
14	PGF-4184	1	Vent plug
15	BTF-708	1	Pinion and gear hub
16	PGF-8686	1	* Bevel gear
17	BTF-743	6	Bevel gear screw
17A	PGF-9436	2	Locking wire
18	PGF-8599	1	Gear and hub
19	BTF-904	1	Washer
20	313071	2	Bearing cup
21	312155	2	Bearing cone and rollers
22	BTF-745	As req'd.	Shim - .020" thick
23	BTF-746	As req'd.	Shim - .007" thick
24	BTF-747	As req'd.	Shim - .005" thick
25	BTF-739	1	Bearing retainer
26	BRF-693	4	Cap screw
27	PGF-8630	1	Gasket (paper)
28	PGF-8631	As req'd.	Shim - .003" thick
29	PGF-8632	As req'd.	Shim - .005" thick
30	PGF-8633	As req'd.	Shim - .010" thick
31	BTF-832	6	Stud
33	PG-1633	1	Pinion carrier
34	313209	1	Bearing cup
35	312549	1	Bearing cone and rollers
36	313448	1	Bearing cup
37	312991	1	Bearing cone and rollers
38	PGF-8686	1	* Bevel pinion
39	PGF-8714	As req'd.	Shim - .003" thick
40	PGF-8715	As req'd.	Shim - .015" thick
41	PGF-8595	1	Retainer
42	PGF-4852	1	Washer
43	PGF-5240	1	Oil seal
44	PGF-4865	As req'd.	Gasket
45	PGF-4864	1	Washer
46	PGF-4667	1	Nut
47	MUJCO-5496-J	1	Fitting yoke
48	PGF-8585	1	Long drive shaft or axle
49	PGX-1353	1	Rear axle housing (no longer furnished. Order Ref. Nos. 49A and 49B)
49A	PGP-1873	1	Rear axle housing with studs Ref. No. 50
49B	PGF-10201	1	Spacer
50	BTF-890	12	Stud
51	BTF-749	1	Gasket
52	PGF-8612	1	Oil seal
53	PGF-3084	1	Taper bushing
54	PGF-8583	1	Short drive shaft or axle
55	PGF-4702	2	Axle stud
56	PGF-3261	2	Axle bracket stud
57	PGU-1657	1	Axle bracket and cap

Note: @ Bearing cap not sold separately. Order complete gear carrier casting, PGU-1652.
 * Bevel gear and bevel pinion sold in matched sets only.

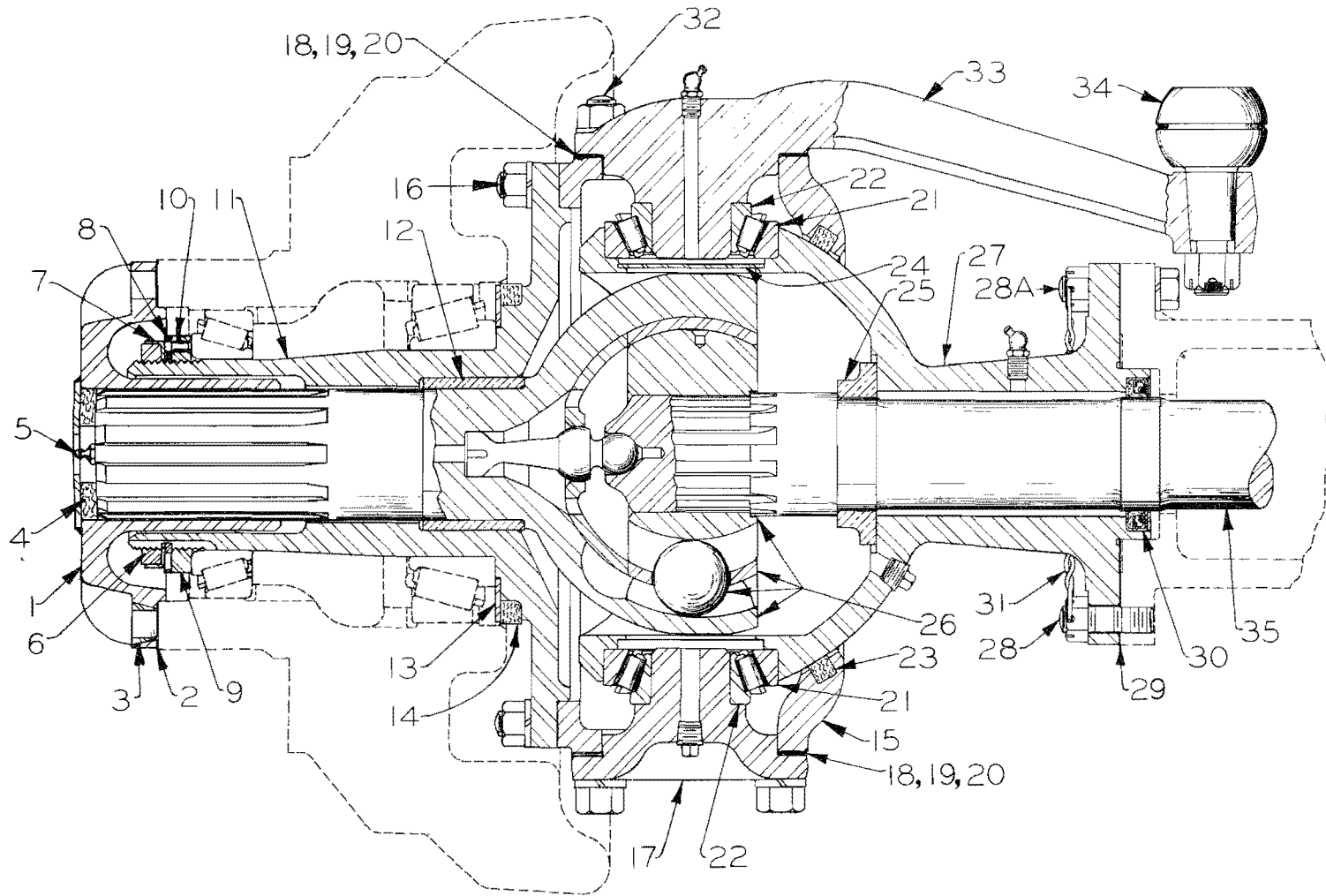

Figure 31. Left Rear Axle Steering Knuckle and Universal Joint

REF. NO.	PART NO.	QUANTITY	DESCRIPTION
1	PGF-9377	1	Driving hub or flange
2	PGF-3186	1	Gasket
3	PGF-3610	4	Dowel bushing
4	PGF-7012	1	Felt
5	064456	1	Grease fitting
6	PGF-5436	1	Lock nut
7	PGF-5439	1	Lock washer
8	PGF-5438	1	Washer
9	PGU-5437	1	Adjusting nut with pin (includes Ref. No. 10)
10	PGF-3677	1	Adjusting nut pin
11	PGF-5433	1	Steering knuckle
12	PGF-5591	1	Steering knuckle bushing
13	PGF-4358	1	Washer
14	PGF-4360	1	Felt
15	PG-1794	1	Knuckle flange
16	PGF-4361	12	Stud
17	PGF-4341	1	Steer bearing cap
18	PGF-4345	As req'd.	Shim - .005" thick
19	PGF-4346	As req'd.	Shim - .007" thick
20	PGF-4347	As req'd.	Shim - .020" thick
21	313380	2	Bearing cap
22	312836	2	Bearing cone and rollers
23	PGF-4362	1	Felt
24	PGF-4339-2	1	Grease retainer
25	PG-1622	1	Axle retainer
26	PGF-8568	1	* Drive joint group
27	PGF-8804	1	Trunnion socket
28	PGF-4996	2	Stud
28A	BTF-957	7	Cap screw
29	PGF-3184	1	Gasket
30	PGF-8612	1	Oil seal
31	PGF-9486	3	Locking wire
32	PGF-4350	4	Steering arm stud
33	PGF-4340	1	Steering arm
34		1	Steering arm ball
35		1	Drive shaft or axle

Note: * Drive joint repair parts not sold separately.
Order complete drive joint group.

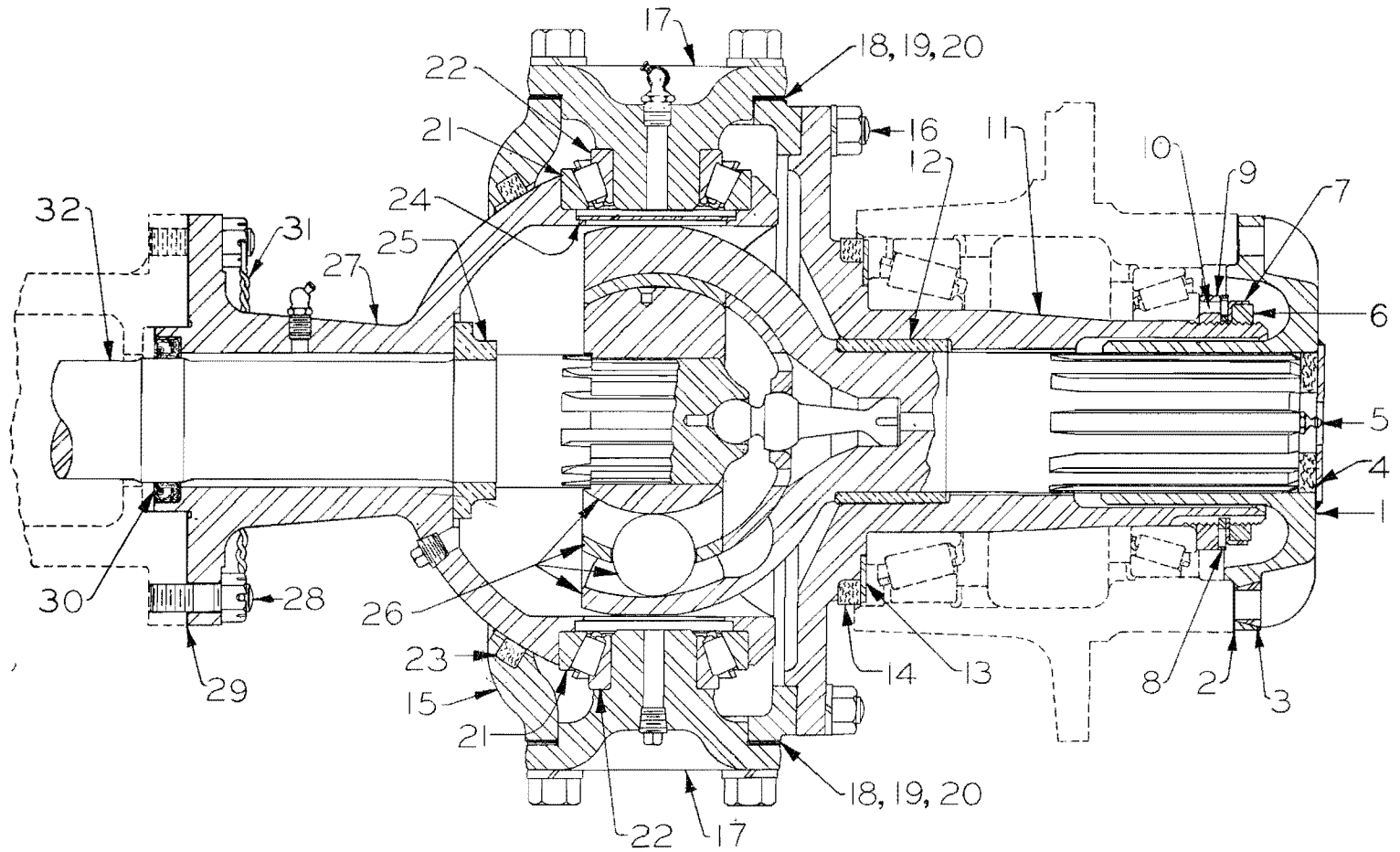

Figure 32. Right Rear Axle Steering Knuckle and Universal Joint

REF. NO.	PART NO.	QUANTITY	DESCRIPTION
1	PGF-9377	1	Driving hub or flange
2	PGF-3186	1	Gasket
3	PGF-3610	4	Dowel bushing
4	PGF-7012	1	Felt
5	O64456	1	Grease fitting
6	PGF-5436	1	Lock nut
7	PGF-5439	1	Lock washer
8	PGF-5438	1	Washer
9	PGU-5437	1	Adjusting nut with pin (includes Ref. No. 10)
10	PGF-3677	1	Adjusting nut pin
11	PGF-5433	1	Steering knuckle
12	PGF-5591	1	Steering knuckle bushing
13	PGF-4358	1	Washer
14	PGF-4360	1	Felt
15	PG-1794	1	Knuckle flange
16	PGF-4361	12	Stud
17	PGF-4341	2	Steer bearing cap
18	PGF-4345	As req'd.	Shim - .005" thick
19	PGF-4346	As req'd.	Shim - .007" thick
20	PGF-4347	As req'd.	Shim - .020" thick
21	313380	2	Bearing cup
22	312836	2	Bearing cone and rollers
23	PGF-4362	1	Felt
24	PGF-4339-2	1	Grease retainer
25	PG-1622	1	Axle retainer
26	PGF-8568	1	* Drive joint group
27	PGF-8804	1	Trunnion socket
28	PGF-4996	9	Stud
29	PGF-3184	1	Gasket
30	PGF-8612	1	Oil seal
31	PGF-9486	3	Locking wire
32		1	Drive shaft or axle

Note: * Drive joint repair parts not sold separately.
Order complete drive joint group.

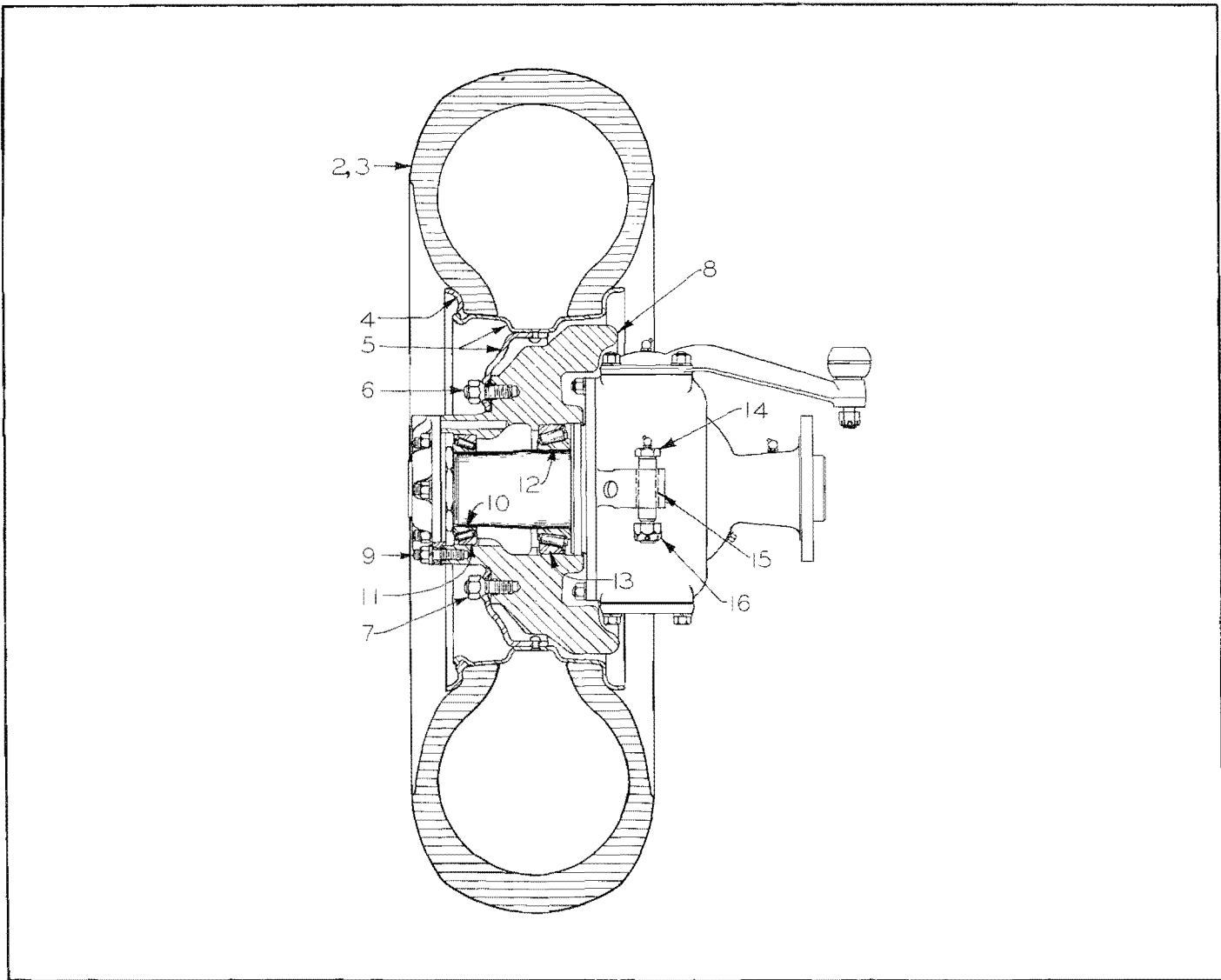
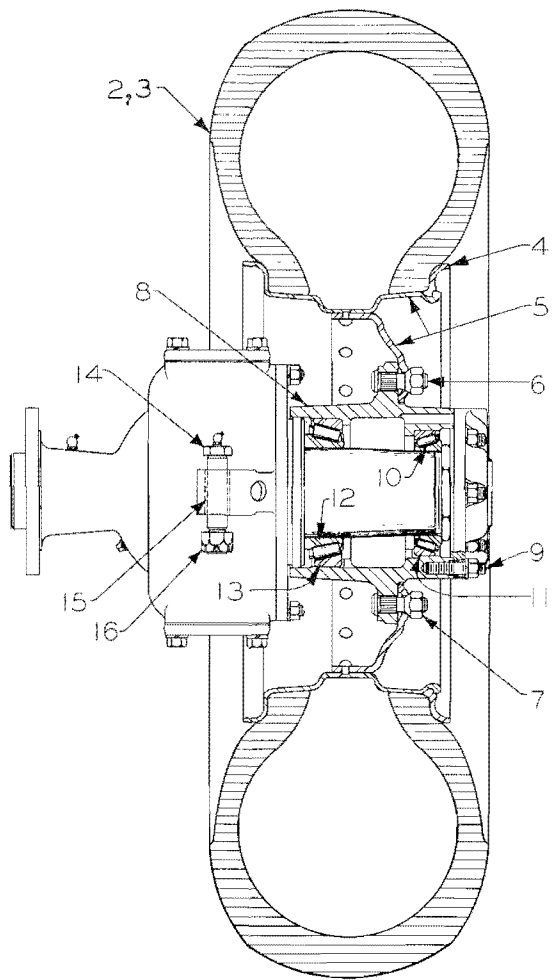

Figure 33. Left Rear Axle Steering Knuckle, Wheel and Tire

REF. NO.	PART NO.	QUANTITY	DESCRIPTION
2		1	* Tire - 14.00 x 20 - 14 ply
3		1	Tube - 14.00 x 20 with TR-220 air-water valve
4	PGF-9392	1	Locking ring
5	PGF-9588	1	Wheel with rim
6	PGF-9591	10	Wheel stud
7	PGF-9396	10	Wheel stud nut
8	PGU-1714	1	Wheel hub with studs and nuts (includes Ref. Nos. 6, 7 and 9)
9	BTF-831	8	Stud
10	312814	1	Bearing cone and rollers
11	313366	1	Bearing cup
12	312888	1	Bearing cone and rollers
13	313407	1	Bearing cup
14	PGF-8757	1	Fork bolt
15	PGF-8753	1	Knuckle flange bushing
16	727011	1	Castellated nut

Note: * Lug type-Road Grader



REF. NO.	PART NO.	QUANTITY	DESCRIPTION
2		1	* Tire - 14.00 x 20 - 14 ply
3		1	Tube - 14.00 x 20 with TR-220 air-water valve
4	PGF-9392	1	Locking ring
5	PGF-9588	1	Wheel with rim
6	PGF-9391	10	Wheel stud
7	PGF-9396	10	Wheel stud nut
8	PGU-1695	1	Wheel hub with studs Ref. No. 9
9	BTF-831	8	Stud
10	312814	1	Bearing cone and rollers
11	313366	1	Bearing cup
12	312888	1	Bearing cone and rollers
13	313407	1	Bearing cup
14	PGF-8757	1	Fork bolt
15	PGF-8753	1	Knuckle flange bushing
16	727011	1	Castellated nut
	PGF-5131	1	& Tire chain - special order (one each used on all four tires)

Note: * Lug type-Road Grader
& Indicates part not illustrated

Figure 34. Right Rear Axle Steering Knuckle, Wheel and Tire

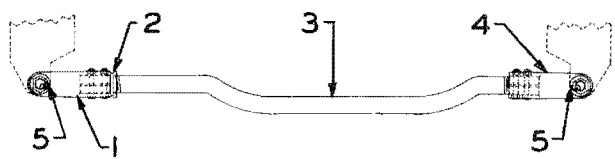

B/M PGU-1849

REF. NO.	PART NO.	QUANTITY	DESCRIPTION
1	PG-1663	1	Fork
2	PGF-3955	1	Adjusting nut
3	PGF-5695	1	Tie rod
4	PG-1664	1	Fork
5	PGF-5502	2	Pin

Figure 35. Rear Axle Tie Rod

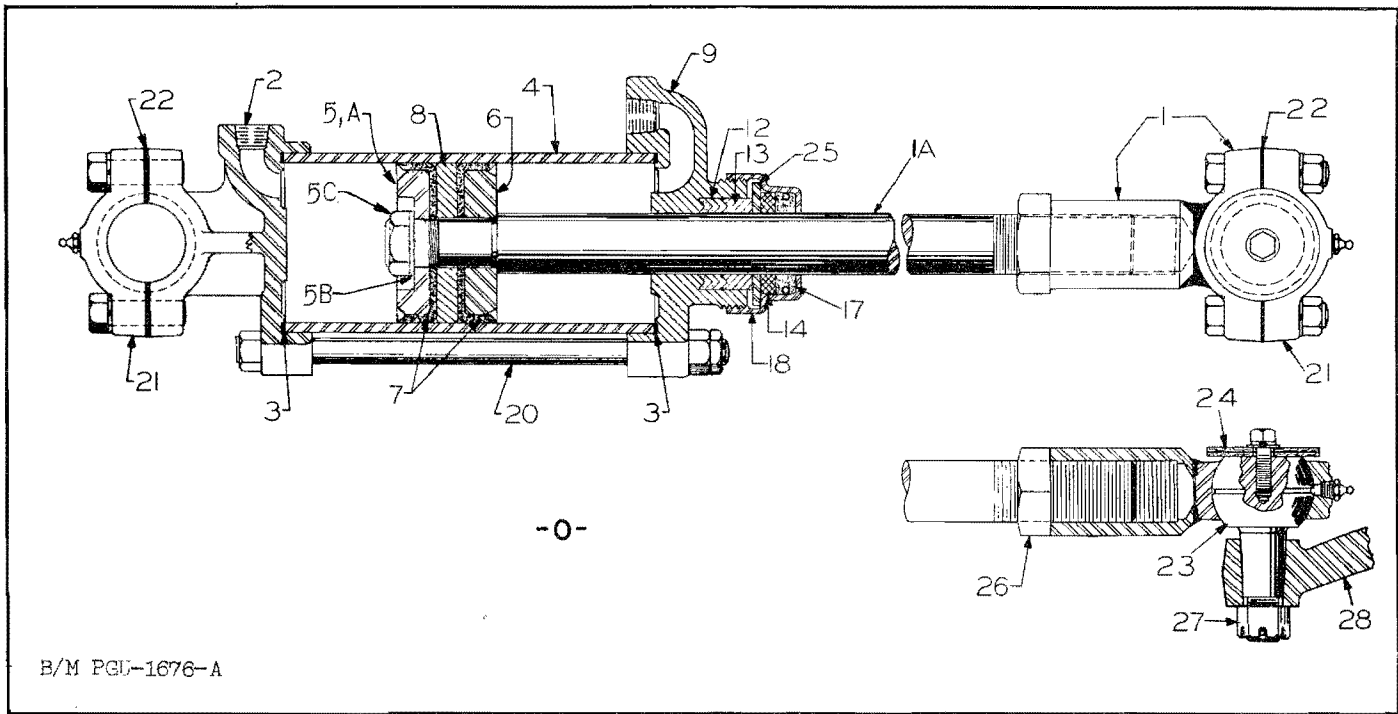

Figure 36. Rear Axle Steering Ram

REF. NO.	PART NO.	QUANTITY	DESCRIPTION
0	PGU-1676-A	1	Steering ram group (includes Ref. Nos. 1 to 27 inclusive except Ref. No. 5)
1	PGF-9453	1	Rod end
1A	PGF-9274	1	Piston rod
2	PG-707	1	Base
3	PGF-1687	2	Gasket
4	PGF-9273	1	Cylinder
5	PGF-1157	1	Outer spreader (no longer furnished. Order Ref. Nos. 5A, 5B and 5C)
5A	PGF-10804	1	Outer spreader
5B	770022	1	Lock washer
5C	726013	1	Jam nut
6	PGF-1158	1	Inner spreader
7	RGF-4378	2	Cup
8	PG-320	1	Piston
9	PG-1342	1	Head
12	RGF-4382	4	Chevron packing ring
13	PG-1348	1	Press ring
14	PGF-6997	1	Felt
17	PGF-1699	1	Wiper
18	PGF-7019	1	Cap
20	PGF-3504	4	Tie rod
21	PGF-9487	2	Ball cap
22	MGF-1992	12	Shim
23	PGF-3317	1	Steering arm ball
24	PGF-3318	1	Washer
25	PGF-7025	1	Retainer
26	726015	1	Jam nut
27	737008	1	Slotted nut
28		1	Steering arm

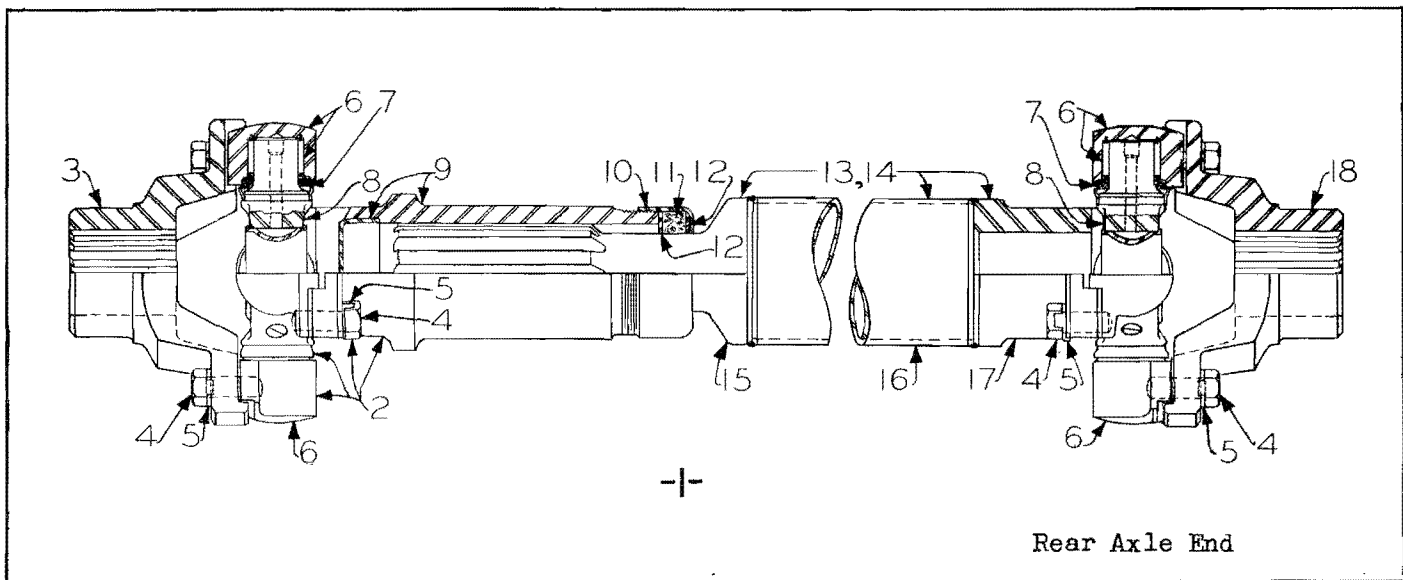
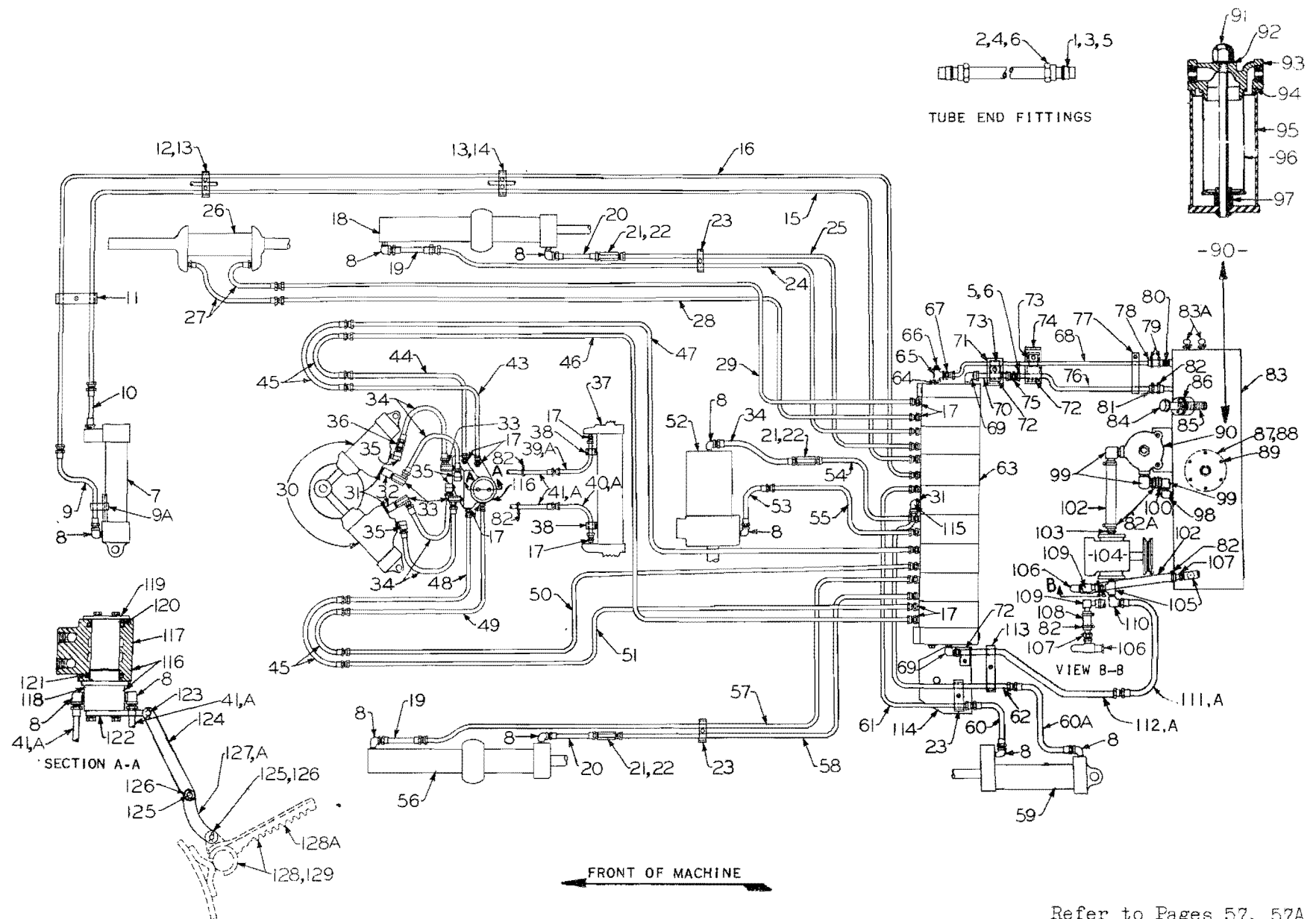

Figure 37. Rear Propeller Shaft

REF. NO.	PART NO.	QUANTITY	DESCRIPTION
1	PGF-8822	1	Propeller shaft, complete
	MUJCO-114-7012	2	Spider and bearing group (includes Ref. Nos. 4,5,6,7 and 8)
2	MUJCO-2-7015	1	Joint group (includes Ref. Nos. 4 to 12 inclusive)
3	MUJCO-6080-J	1	Fitting yoke
4	MUJCO-3562-J	16	Cap screw
5	MUJCO-3551-J	8	Cap screw lock plate
6	MUJCO-113-7002	8	Bearing group
7	MUJCO-3571-J	8	Cork trunnion washer
8	MUJCO-112-7004	2	Spider group
9	MUJCO-6A-7000	1	Slip yoke group
10	MUJCO-949-J	1	Felt retainer
11	MUJCO-6X111	1	Felt washer
12	MUJCO-950-J	2	Retainer washer
13	MUJCO-2S-4333	1	Propeller tube and joint group (includes Ref. Nos. 4,5,6,7,8 and 14)
14	MUJCO-42-4333	1	Propeller tube group (includes Ref. Nos. 15,16 and 17)
15	MUJCO-2176-J	1	Stub end
16	MUJCO-4375-J-178	1	Tube (only)
17	MUJCO-3747-J	1	Weld yoke
18	MUJCO-5496-J	1	Fitting yoke



Refer to Pages 57, 57A and 57B for Part Numbers

Figure 38. Hydraulic Piping Diagram for UD-14A Engine

REF. NO.	PART NO.	QUANTITY	DESCRIPTION
1	PGF-9496-5	1	Coupling sleeve (for 3/8" OD tube)
2	PGF-9497-5	1	Coupling nut (for 3/8" OD tube)
3	PGF-9496-7	44	Coupling sleeve (for 5/8" OD tube)
4	PGF-9497-7	44	Coupling nut (for 5/8" OD tube)
5	PGF-9496-8	5	Coupling sleeve (for 3/4" OD tube)
6	PGF-9497-8	5	Coupling nut (for 3/4" OD tube)
7		1	Front steer ram
8	PGF-9537-4	11	Elbow
9	PGF-9450	1	Hydraulic hose - 72-3/4" overall length
9A	PGF-10532	1	Hose clamp (first used on machine H-264)
10	PGF-9449	1	Hydraulic hose - 61-1/8" overall length
11	PGF-9529	2	Pipe clamp
12	PGF-9531	1	Pipe clamp
13	PGF-9532	5	Plate
14	PGF-9533	4	Pipe clamp
15	PGF-9462	1	* Tube - 5/8" OD x 191" (approx.)
16	PGF-9463	1	* Tube - 5/8" OD x 190-1/2" (approx.)
17	PGF-10143-7	21	Coupling connector
18		1	R.H. blade lift ram
19	PGF-9445	2	Hydraulic hose - 35-7/8" overall length
20	PGF-9444	2	Hydraulic hose - 29-1/8" overall length
21	PGF-9455	3	Check valve body
22	PGF-9454	3	Check valve poppet
23	PGF-7524	8	Pipe clamp
24	PGF-9460	1	* Tube - 5/8" OD x 70-1/2" (approx.)
25	PGF-9461	1	* Tube - 5/8" OD x 72-3/4" (approx.)
26		1	Scarifier ram
27	PGF-9442	2	Hydraulic hose - 22" overall length
28	PGF-9458	1	* Tube - 5/8" OD x 134-1/2" (approx.)
29	PGF-9459	1	* Tube - 5/8" OD x 135-1/2" (approx.)
30		1	Circle reverse hydraulic motor
31	532138	3	Pipe nipple
32	525004	2	Coupling
33	PGF-9456	4	Right angle adapter union
34	PGF-9441	5	Hydraulic hose - 19" overall length
35	PGF-10104-4	4	Elbow
36	HCF-362	1	Adapter union (never reqd. Last used on machine H-1006)
37		1	Blade side shift ram
38	PGF-9970	2	Pipe clamp
39	PGF-9478	1	@* Tube - 5/8" OD x 22-13/16" (approx.)
39A	PGF-10493	1	#* Tube - 5/8" OD x 5-3/4" (approx.)
39A	PGF-10491	1	&* Tube - 5/8" OD x 13-1/2" (approx.)
40	PGF-9479	1	@* Tube - 5/8" OD x 30-7/16" (approx.)
40A	PGF-10491	1	%* Tube - 5/8" OD x 13-1/2" (approx.)
41	PGF-10133	2	@ Hydraulic hose - 18" overall length
41A	PGF-10490	2	% Hydraulic hose - 31-3/8" overall length
43	PGF-9476	1	* Tube - 5/8" OD x 96" (approx.)
44	PGF-9468	1	* Tube - 5/8" OD x 96" (approx.)
45	PGF-9446	4	Hydraulic hose - 42-1/2" overall length
46	PGF-9469	1	* Tube - 5/8" OD x 153" (approx.)

Note: Hydraulic hose dimensions given are overall lengths including end fittings.
 * Includes two, Ref. 3, PGF-9496-7 sleeves, and two, Ref. 4, PGF-9497-7 nuts.
 @ Machines H-100 to H-442 inclusive. & Machines H-904 and up.
 # Machines H-444 to H-902 inclusive. % Machines H-444 and up.

(continued)

(Refer to Figure 38 for Reference Numbers)

REF. NO.	PART NO.	QUANTITY	DESCRIPTION
47	PGF-9477	1	* Tube - 5/8" OD x 157" (approx.)
48	PGF-9474	1	* Tube - 5/8" OD x 95-1/2" (approx.)
49	PGF-9470	1	* Tube - 5/8" OD x 99-3/4" (approx.)
50	PGF-9471	1	* Tube - 5/8" OD x 158-1/2" (approx.)
51	PGF-9475	1	* Tube - 5/8" OD x 157-3/4" (approx.)
52		1	High lift ram
53	PGF-9443	1	Hydraulic hose - 21-3/8" overall length
54	PGF-9466	1	* Tube - 5/8" OD x 43" (approx.)
55	PGF-9467	1	* Tube - 5/8" OD x 45-3/4" (approx.)
56		1	L.H. blade lift ram
57	PGF-9472	1	* Tube - 5/8" OD x 69" (approx.)
58	PGF-9473	1	* Tube - 5/8" OD x 69-1/4" (approx.)
59		1	Rear steer ram
60	PGF-9440	1	Hydraulic hose - 15-3/8" overall length
60A	PGF-9440	1	∅ Hydraulic hose - 15-3/8" overall length
60A	PGF-10517	1	£ Hydraulic hose - 11-7/8" overall length
61	PGF-9464	1	* Tube - 5/8" OD x 123" (approx.)
62	PGF-9465	1	* Tube - 5/8" OD x 111-1/4" (approx.)
63		1	Valve bank group
64	532046	1	Pipe nipple
65	537002	1	Tee
66	810001	1	Square head pipe plug
67	PGF-10143-5	1	Coupling connector
68	PGF-9482	1	** Tube - 3/8" OD x 114-1/4" (approx.)
69	PGF-10144-8	2	Elbow
70	PGF-9825	1	*** Tube - 3/4" OD x 7-15/16"
71	PGF-9523	1	Pipe clamp angle
72	PGF-9522	4	Pipe clamp
73	PGF-9520	2	Pipe clip
74	PGF-9525	1	Pipe clamp support
75	PGF-9812-8	1	Coupling union
76	PGF-9481	1	Tube - 3/4" OD x 105" (approx.) (includes 1 only of Ref. Nos. 5 and 6)
77	PGF-9524	1	Pipe clamp
78	PGF-7481	1	Hose
79	034105	2	Hose clamp
80	PGF-9534-2	1	Adapter
81	TF-1310	1	Hose
82	034012	8	Hose clamp
82A	PGF-10566-7	4	Hose clamp
83	PGF-8973	1	Oil tank
	PGF-8932	1	Oil tank support bracket-RH (not illustrated)
	PGF-8933	1	Oil tank support bracket-LH (not illustrated)
83A	ASF-5766	2	Oil tank pet cock
84	PGF-9374	1	Breather
85	PGF-8890	1	Filler screen
86	PGF-8975	1	Filler screen flange gasket
87	PG-559	1	Hand hole cover

Note: * Includes two, Ref. 3, PGF-9496-7 sleeves, and two, Ref. 4, PGF-9497-7 nuts.

** Includes one, Ref. 1, PGF-9496-5 sleeve, and one, Ref. 2, PGF-9497-5 nut.

*** Includes two, Ref. 5, PGF-9496-8 sleeves, and two, Ref. 6, PGF-9497-8 nuts.

∅ Machines H-100 to H-582 inclusive.

£ Machines H-584 and up.

(continued)

(Refer to Figure 38 for Reference Numbers)

REF. NO.	PART NO.	QUANTITY	DESCRIPTION
88	PGF-2096	1	Hand hole cover gasket
89	PGF-2418	6	Stud-cover to tank
90	PGU-1873	1	Hydraulic oil strainer group (includes Ref. Nos. 91 to 97 inclusive)
91	PGF-2354	1	Nut
92	PGF-2264	1	Washer
93	PG-1776	1	Head
94	PGF-2265	1	Gasket
95	PGF-7328	1	Tank
96	PGX-2261	1	Screen
97	NES-997	1	Spring
98	PGF-9538-5	1	Elbow
99	PGF-9535-6	3	Adapter elbow
100	CSF-948	1	Hose
102	PGF-9628	2	Hose
103	PGF-9534-10	1	Adapter
104		1	Hydraulic oil pump
105	PGF-9539-5	2	Tee
106	PGF-7817-900	1	Relief valve
107	PGF-9534-9	2	Adapter
108	PGF-6545	1	Hose
109	PGF-9536-6	1	Elbow
110	PGF-9537-5	1	Elbow
111	PGF-9439	1	∅ Hydraulic hose - 11-1/2" overall length
111A	PGF-10518	1	£ Hydraulic hose - 14-1/4" overall length
112	PGF-9480	1	∅*** Tube - 3/4" OD x 98" (approx.)
112A	PGF-10531	1	£*** Tube - 3/4" OD x 95-1/4" (approx.)
113	PGF-9527	1	Pipe clamp
114	PGF-9526	1	Pipe clamp bracket
115	PGF-10145-7	1	Elbow
116	PGP-1813	1	Swivel junction group (includes Ref. Nos. 117 and 118)
117		1	⊖ Junction block
118		1	⊖ Swivel plug
119	PGF-8989	1	Washer
120	PGF-9648-2	1	"O" ring
121	PGF-9648-6	1	"O" ring
122	PGF-9413	1	Connection plate
123	PGF-9414	1	Pin
124	PGF-9751	1	Link
125	PSF-2264	4	Pin
126	PGF-5930	4	Washer
127	PGF-9750	1	@ Connector
127A	PGF-10503	1	% Connector
128	PGF-8776	1	@ Tube with tilting links (incl. Ref. No. 128A)
128A	PGF-8776-2	2	Tilt link (welds on)
129	PGF-10502	1	% Tube with tilting links (incl. Ref. No. 128A)

Note: *** Includes two, Ref. 5, PGF-9496-8 sleeves, and two, Ref. 6, PGF-9497-8 nuts.
∅ Machines H-100 to H-582 inclusive. @ Machines H-100 to H-442 inclusive.
£ Machines H-584 and up. % Machines H-444 and up.
⊖ Indicates parts not sold separately. Order Ref. No. 116 - PGP-1813 swivel junction group from your nearest Austin-Western distributor.

FACTORY ATTACHED CONNECTIONS

Note: In ordering hose always be governed by the overall length. See (L)

1/2"-14 NPT FOR 1/2" HYD. HOSE
3/4"-14 NPT FOR 3/4" HYD. HOSE

15/16"-16N THD. FOR 1/2" HYD. HOSE
1-1/16"-16N THD. FOR 3/4" HYD. HOSE

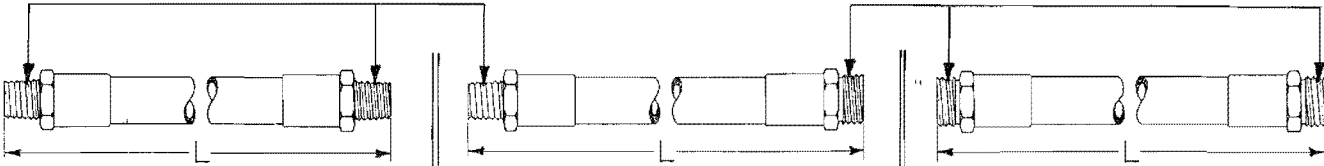

1/2" I.D. HYD. HOSE		1/2" I.D. HYD. HOSE		1/2" I.D. HYD. HOSE	
Length (L)	Part No.	Length (L)	Part No.	Length (L)	Part No.
19"	PGF-9441	11-7/8"	PGF-10517	22-3/8"	SPF-1128
29-1/8"	PGF-9444	12-3/4"	ASF-5423	42-1/2"	PGF-9446
45-3/8"	PGF-10772	15-3/8"	PGF-9440		
51-7/8"	PGF-10773	18"	PGF-10133		
60-7/8"	PGF-10771	21-3/8"	PGF-9443		
		22"	PGF-9442		
		24-1/4"	PGF-9788		
		28-7/8"	SPF-1131		
		31-3/8"	PGF-10490		
		35-7/8"	PGF-9445		
		36-1/4"	PGF-9759		
		61-1/8"	PGF-9449		
		72-3/4"	PGF-9450		
3/4" I.D. HYD. HOSE		3/4" I.D. HYD. HOSE		3/4" I.D. HYD. HOSE	
		11-1/2"	PGF-9439		
		14-1/4"	PGF-10518		



Field Service Hydraulic Hose and Connections

REF. NO.	PART NO. (1/2" I.D. HOSE)	PART NO. (3/4" I.D. HOSE)	QTY. PER HOSE END	DESCRIPTION
1	HCF-368	HCF-334	1	Stem
2	1/2"-14 NPT	3/4"-14 NPT	1	Stem
3	PGF-9946	PGF-9945	2	Clamp
4	15/16"-16N THD.	1-1/16"-16N THD.	2	Cap screw
5	PGF-2077	HC-47	2	Lock washer
6	742166	742323	2	Hex nut
7	778010	778011	2	Hydraulic hose-specify length wanted
7	722002	722003	2	
7	1/2" I.D.	3/4" I.D.		

Make up your own hose by keeping a supply of hydraulic hose (in random length) and hose clamps on hand. To determine length of hose required measure the overall length of the hose you wish to duplicate and deduct 2". Cut hose with a high speed hacksaw blade having 18 or 24 teeth per inch.

Figure 38A. Hydraulic Hose Chart

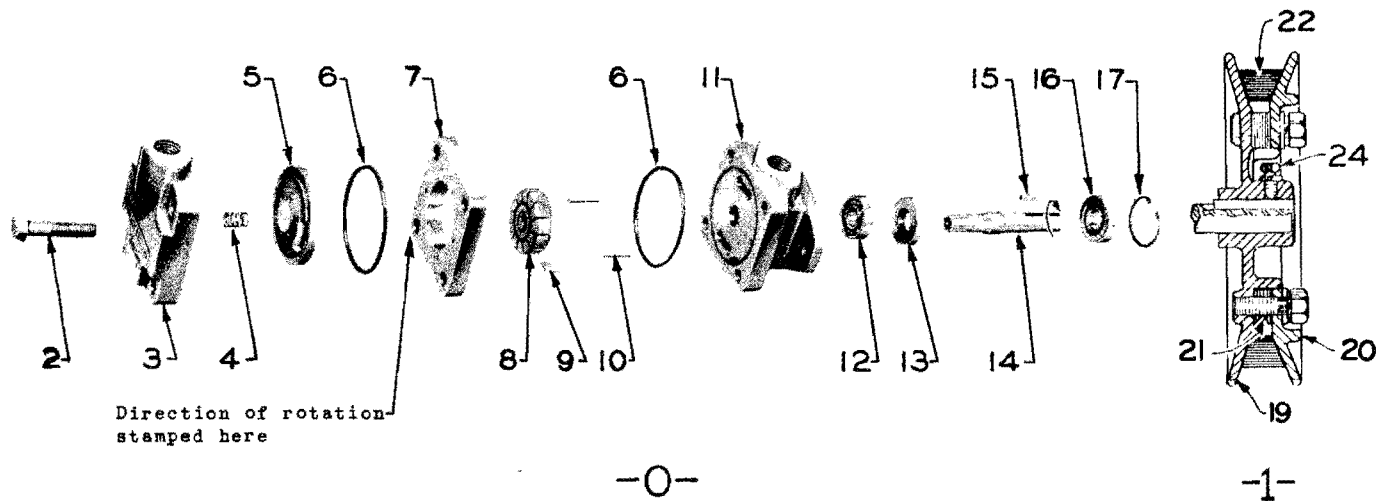
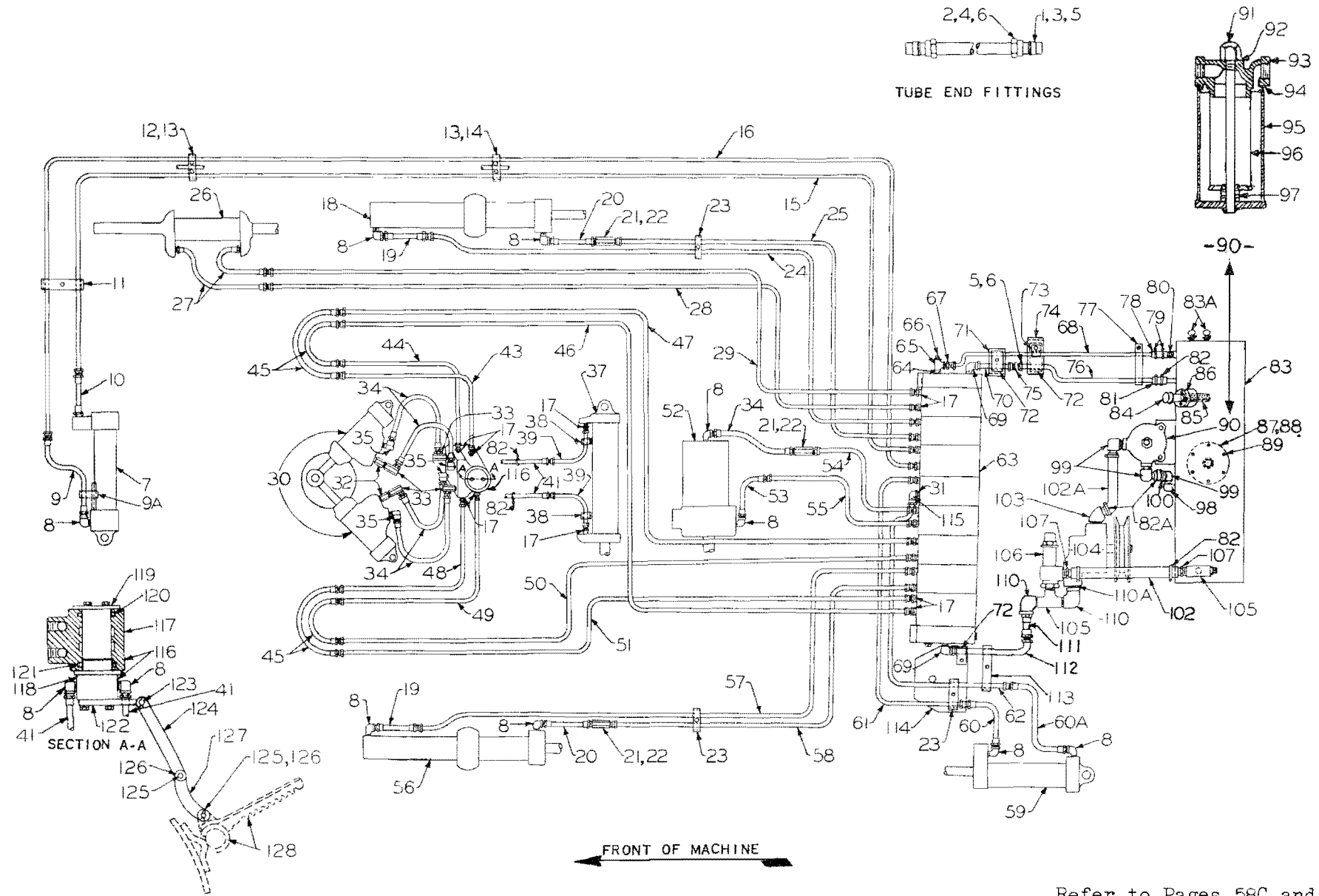

Figure 38B. Hydraulic Pump and Pulley for UD-14A Engine
(Machines H-2540 and up)

REF. NO.	PART NO.	QUANTITY	DESCRIPTION
0	PGF-11098	1	Pump group - R.H. rotation (includes Ref. Nos. 2 to 17 inclusive)
1	PGUS-9161	1	Pulley group (includes Ref. Nos. 19, 20, 21 and 24)
2	V-1329	4	Cap screw
3	V-124729	1	Cover
4	V-114139	1	Spring
5	V-114203	1	Pressure plate
6	V-84120	2	Seal ring
7	V-114154	1	Ring
8	V-117065	1	Rotor
9	V-2010	12	Vane
10	V-2161	2	Pin
11	V-119986	1	Body
12	V-1703	1	Bearing
13	V-23726	1	Oil seal
14	V-116644	1	Shaft
15	V-5881	1	Shaft key
16	V-98574	1	Bearing
17	V-109975	1	Snap ring
19	FG-921	1	Pulley - inner half
20	FG-920	1	Pulley - outer half
21	PGF-3923	As req'd.	Shim (4 supplied in FGUS-9161 pulley group)
22	PGF-3060	1	"V" belt
24	755030	1	Set screw - cup point



Refer to Pages 58C and 58D for Part Numbers

Figure 38C. Hydraulic Piping Diagram for UD-14A Engine
 (Machines H-2540 and up)

REF. NO.	PART NO.	QUANTITY	DESCRIPTION
1	PGF-9496-5	1	Coupling sleeve (for 3/8" OD tube)
2	PGF-9497-5	1	Coupling nut (for 3/8" OD tube)
3	PGF-9496-7	44	Coupling sleeve (for 5/8" OD tube)
4	PGF-9497-7	44	Coupling nut (for 5/8" OD tube)
5	PGF-9496-8	5	Coupling sleeve (for 3/4" OD tube)
6	PGF-9497-8	5	Coupling nut (for 3/4" OD tube)
7		1	Front steer ram
8	PGF-9537-4	11	Elbow
9	PGF-9450	1	Hydraulic hose - 72-3/4" overall length
9A	PGF-10532	1	Hose clamp
10	PGF-9449	1	Hydraulic hose - 61-1/8" overall length
11	PGF-9529	2	Pipe clamp
12	PGF-9531	1	Pipe clamp
13	PGF-9532	5	Plate
14	PGF-9533	4	Pipe clamp
15	PGF-9462	1	* Tube - 5/8" OD x 191" (approx.)
16	PGF-9463	1	* Tube - 5/8" OD x 190-1/2" (approx.)
17	PGF-10143-7	21	Coupling connector
18		1	R.H. blade lift ram
19	PGF-9445	2	Hydraulic hose - 35-7/8" overall length
20	PGF-9444	2	Hydraulic hose - 29-1/8" overall length
21	PGF-9455	3	Check valve body
22	PGF-9454	3	Check valve poppet
23	PGF-7524	8	Pipe clamp
24	PGF-9460	1	* Tube - 5/8" OD x 70-1/2" (approx.)
25	PGF-9461	1	* Tube - 5/8" OD x 72-3/4" (approx.)
26		1	Scarifier ram
27	PGF-9442	2	Hydraulic hose - 22" overall length
28	PGF-9458	1	* Tube - 5/8" OD x 134-1/2" (approx.)
29	PGF-9459	1	* Tube - 5/8" OD x 135-1/2" (approx.)
30		1	Circle reverse hydraulic motor
31	532138	1	Pipe nipple
32	PGF-10893	2	Fitting
33	PGF-9456	4	Right angle adapter union
34	PGF-9441	5	Hydraulic hose - 19" overall length
35	PGF-10104-4	4	Elbow
37		1	Blade side shift ram
38	PGF-9970	2	Pipe clamp
39	PGF-10491	2	* Tube - 5/8" OD x 13-1/2" (approx.)
41	PGF-10490	2	Hydraulic hose - 31-3/8" overall length
43	PGF-9476	1	* Tube - 5/8" OD x 96" (approx.)
44	PGF-9468	1	* Tube - 5/8" OD x 96" (approx.)
45	PGF-9446	4	Hydraulic hose - 42-1/2" overall length
46	PGF-9469	1	* Tube - 5/8" OD x 153" (approx.)
47	PGF-9477	1	* Tube - 5/8" OD x 157" (approx.)
48	PGF-9474	1	* Tube - 5/8" OD x 95-1/2" (approx.)
49	PGF-9470	1	* Tube - 5/8" OD x 99-3/4" (approx.)
50	PGF-9471	1	* Tube - 5/8" OD x 158-1/2" (approx.)
51	PGF-9475	1	* Tube - 5/8" OD x 157-3/4" (approx.)
52		1	High lift ram
53	PGF-9443	1	Hydraulic hose - 21-3/8" overall length
54	PGF-9466	1	* Tube - 5/8" OD x 43" (approx.)
55	PGF-9467	1	* Tube - 5/8" OD x 45-3/4" (approx.)
56		1	L.H. blade lift ram
57	PGF-9472	1	* Tube - 5/8" OD x 69" (approx.)
58	PGF-9473	1	* Tube - 5/8" OD x 69-1/4" (approx.)
59		1	Rear steer ram
60	PGF-9440	1	Hydraulic hose - 15-3/8" overall length
60A	PGF-10517	1	Hydraulic hose - 11-7/8" overall length
61	PGF-9464	1	* Tube - 5/8" OD x 123" (approx.)
62	PGF-9465	1	* Tube - 5/8" OD x 111-1/4" (approx.)
63		1	Valve bank group
64	532046	1	Pipe nipple
65	537002	1	Tee
66	810001	1	Square head pipe plug
67	PGF-10143-5	1	Coupling connector
68	PGF-9482	1	** Tube - 3/8" OD x 114-1/4" (approx.)
69	PGF-10144-8	2	Elbow
70	PGF-9825	1	*** Tube - 3/4" OD x 7-15/16"

Note: Hydraulic hose dimensions given are overall lengths including end fittings.
* Includes two, Ref. 3, PGF-9496-7 sleeves, and two, Ref. 4, PGF-9497-7 nuts.
** Includes one, Ref. 1, PGF-9496-5 sleeve, and one, Ref. 2, PGF-9497-5 nut.
*** Includes two, Ref. 5, PGF-9496-8 sleeves, and two, Ref. 6, PGF-9497-8 nuts.

470A.58C

(continued)

Supplement to #470A Catalog
(5/20/49)

(Refer to Figure 38C for Reference Numbers)

REF. NO.	PART NO.	QUANTITY	DESCRIPTION
71	PGF-9523	1	Pipe clamp angle
72	PGF-9522	4	Pipe clamp
73	PGF-9520	1	Pipe clip
74	PGF-9525	1	Pipe clamp support
75	PGF-9812-8	1	Coupling union
76	PGF-9481	1	Tube - 3/4" OD x 105" (approx.) (includes 1 only of Ref. Nos. 5 and 6)
77	PGF-9524	1	Pipe clamp
78	PGF-7481	1	Hose
79	O34105	2	Hose clamp
80	PGF-9534-2	1	Adapter
81	TF-1310	1	Hose
82	O34012	6	Hose clamp
82A	PGF-10566-7	4	Hose clamp
83	PGF-8973	1	Oil tank
	PGF-8932	1	Oil tank support bracket-RE (not illustrated)
	PGF-8933	1	Oil tank support bracket-LH (not illustrated)
83A	ASF-5766	2	Oil tank pet cock
84	PGF-9374	1	Breather
85	PGF-8890	1	Filler screen
86	PGF-8975	1	Filler screen flange gasket
87	PG-559	1	Hand hole cover
88	PGF-2096	1	Hand hole cover gasket
89	PGF-2418	6	Stud-cover to tank
90	PGU-1873	1	Hydraulic oil strainer group (includes Ref. Nos. 91 to 97 inclusive)
91	PGF-2354	1	Nut
92	PGF-2264	1	Washer
93	PG-1776	1	Head
94	PGF-2265	1	Gasket
95	PGF-7328	1	Tank
96	PGX-2261	1	Screen
97	NES-997	1	Spring
98	PGF-9538-5	1	Elbow
99	PGF-9535-6	3	Adapter elbow
100	CSF-948	1	Hose
102	PGF-11292	1	Hose
102A	MSF-2432	1	Hose
103	PGF-9535-7	1	Adapter
104	PGF-11098	1	Hydraulic oil pump (see Fig. 38B)
105	PGF-9539-5	2	Tee
106	PGF-7817-900	1	Relief valve
107	PGF-9534-9	2	Adapter
110	PGF-9537-5	2	Elbow
110A	532183	1	Nipple
111	PGF-11307	1	Hydraulic hose - 12" overall length
112	PGF-10531	1	*** Tube - 3/4" OD x 95-1/4" (approx.)
113	PGF-9527	1	Pipe clamp
114	PGF-9526	1	Pipe clamp bracket
115	PGF-10145-7	1	Elbow
116	PGP-1813	1	Swivel junction group (includes Ref. Nos. 117 and 118)
117		1	⊖ Junction block
118		1	⊖ Swivel plug
119	PGF-8989	1	Washer
120	PGF-9648-2	1	"O" ring
121	PGF-9648-6	1	"O" ring
122	PGF-9413	1	Connection plate
123	PGF-9414	1	Pin
124	PGF-9751	1	Link
125	PSF-2264	4	Pin
126	PGF-5930	4	Washer
127	PGF-10503	1	Connector
128		1	Tilting arm group

Note: *** Includes two, Ref. 5, PGF-9496-8 sleeves, and two, Ref. 6, PGF-9497-8 nuts.
⊖ Indicates parts not sold separately. Order Ref. No. 116 - PGP-1813 swivel junction group from your nearest Austin-Western distributor.

470A.58D

Supplement to #470A Catalog
(5/20/49)

- 58D -

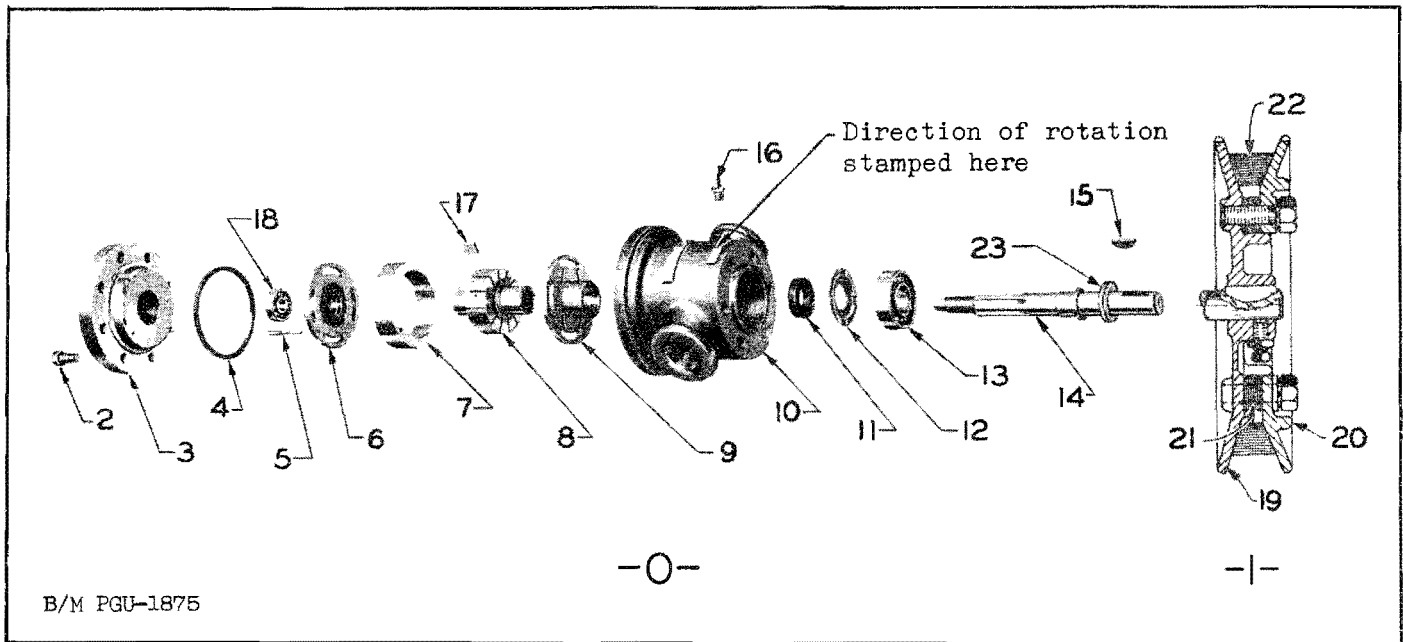

Figure 39. Hydraulic Pump and Pulley for UD-14A Engine

REF. NO.	PART NO.	QUANTITY	DESCRIPTION
0	PGF-9373	1	Pump group-RH rotation (includes Ref. Nos. 2 to 18 inclusive)
1	PGUS-9161	1	Pulley group (includes Ref. Nos. 19, 20 and 21)
2	V-23207	10	Screw
3	V-24064	1	Head
4	V-2021	1	Packing
5	V-2020	1	Ring pin
6	V-2016	1	Bushing
7	V-2013	1	Ring
8	V-6779	1	Rotor
9	V-2015	1	Bushing
10	V-2004	1	Body
11	V-2019	1	Packing
12	V-2017	1	Gland
13	V-1704	1	Bearing
14	V-2025	1	Shaft
15	111010	1	Shaft key
16	064001	1	Lubrication fitting
17	V-6778	12	Vane
18	ND-3200	1	Bearing
19	PG-921	1	Pulley-inner half
20	PG-920	1	Pulley-outer half
21	PGF-3923	4	Shim
22	PGF-3060	1	"V" belt
23	PGF-4759	1	Felt

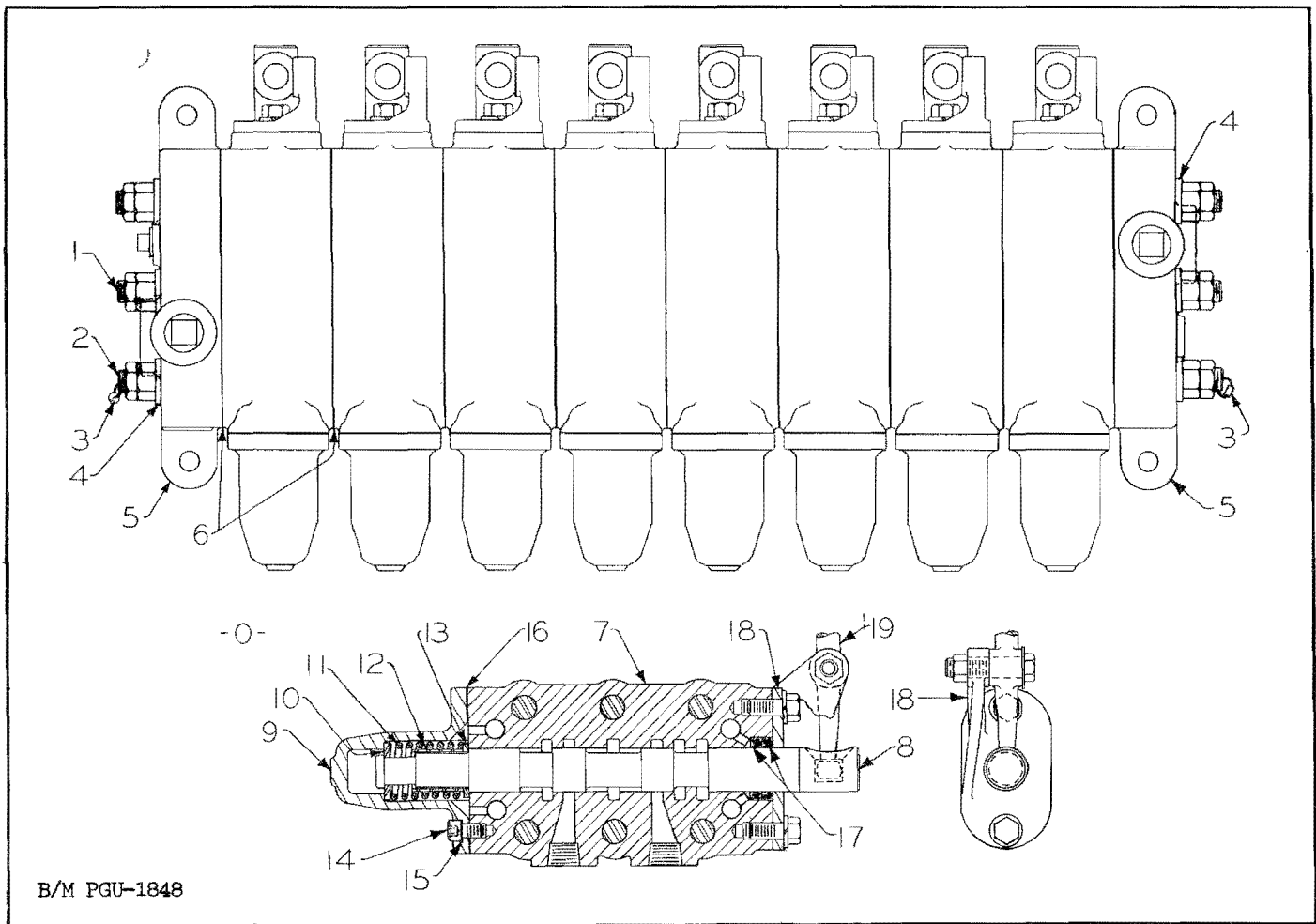
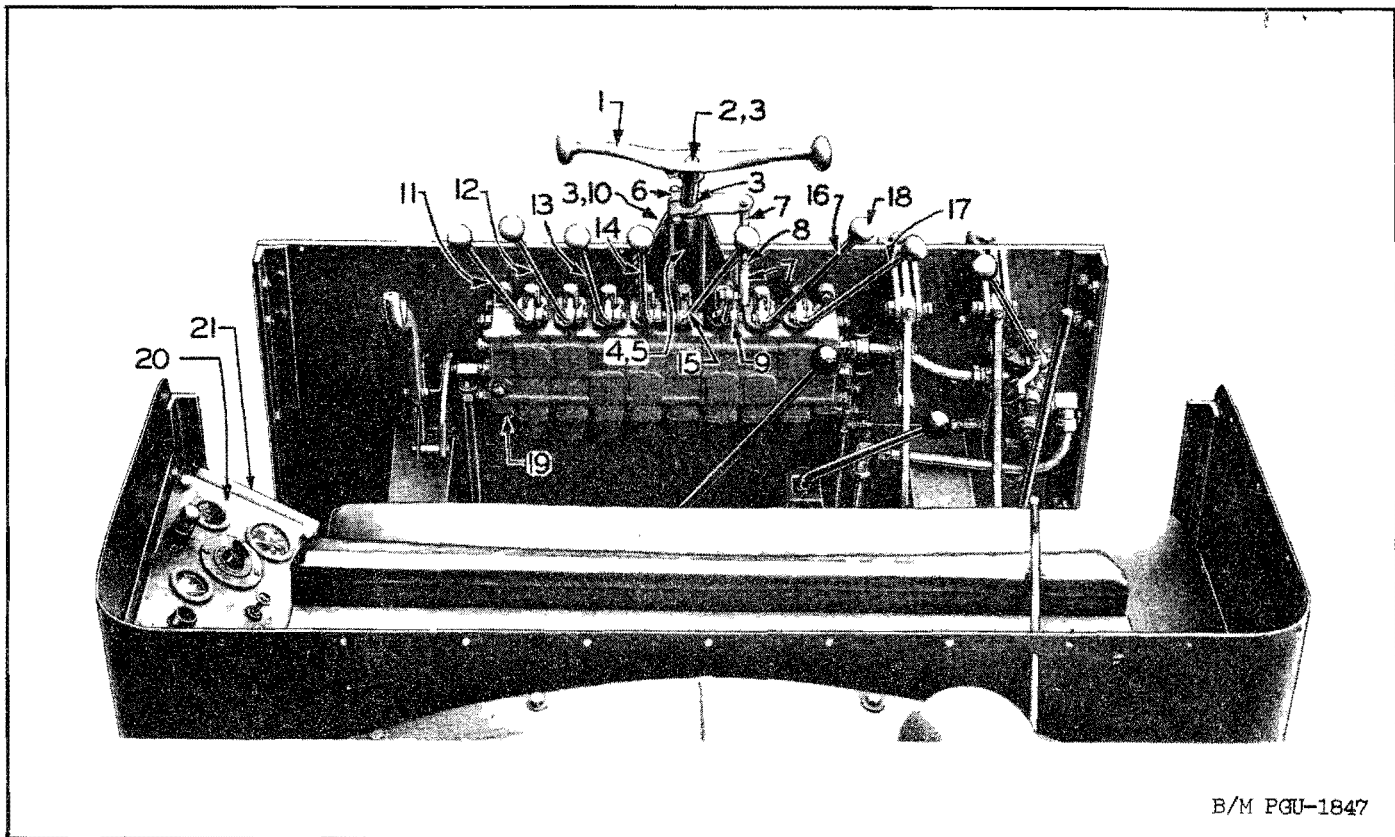

Figure 40. Hydraulic Valve Mechanism

REF. NO.	PART NO.	QUANTITY	DESCRIPTION
0	PGUS-9209	1	Valve bank group (includes Ref. Nos. 1 to 8 inclusive)
1		5	* Tie rod
2		1	* Tie rod
3		2	* Valve bank seal
4		12	* Tie rod washer
5		2	* Valve body end
6		9	* Gasket
7		8	* Valve body
8		8	* Valve plug (movable)
9	PG-1673	8	Valve spring cap
10	PGF-8780	8	Washer
11	PGF-8775	8	Valve spring
12	PGF-8781	8	Sleeve
13	PGF-8785	8	Washer
14	819133	32	Cap screw-hollow head
15	HCF-373	32	Washer
16	PGF-8784	8	Valve spring cap gasket
17	PGF-8946	16	Oil seal
18	PG-1655	8	Valve lever bracket
19		8	Control lever

Note: * Indicates parts not sold separately. Order Ref. No. 0 - PGUS-9209 valve bank group from your nearest Austin-Western Distributor. Gaskets, Ref. No. 16, and oil seals, Ref. No. 17, should also be ordered when PGUS-9209, valve bank group is ordered.



B/M PGU-1847

Figure 41. Hydraulic Valve Controls

REF. NO.	PART NO.	QUANTITY	DESCRIPTION
1	PG-1386	1	Steering lever
2	PGF-9404	1	Steering column shaft
3	111009	3	Woodruff key
4	PG-1785	1	Steering column
5	PGF-9406	2	Steering column bushing
6	PG-1787	1	Steering shaft lever
7	461014	2	Ball and socket joint
8	PGF-9405	1	Steering link adjusting rod
9	PGF-9407	1	Steering valve lever
10	PG-1786	1	* Steering shaft collar
11	PGF-7836	1	Circle reverse valve lever
12	PGF-8961	1	L.H. blade lift valve lever
13	PGF-7832	1	Blade side shift valve lever
14	PGF-7831	1	High lift valve lever
15	PGF-9302	1	Rear steer valve lever
16	PGF-8960	1	R.H. blade lift lever
17	PGF-7835	1	Scarifier valve lever
18	PG-1400	7	Valve lever ball
19	PGF-9331	1	* Valve bank felt
20	PGF-9002	1	Instrument panel
21	PGF-9009	1	Instrument panel support

Note: * Indicates parts not illustrated.

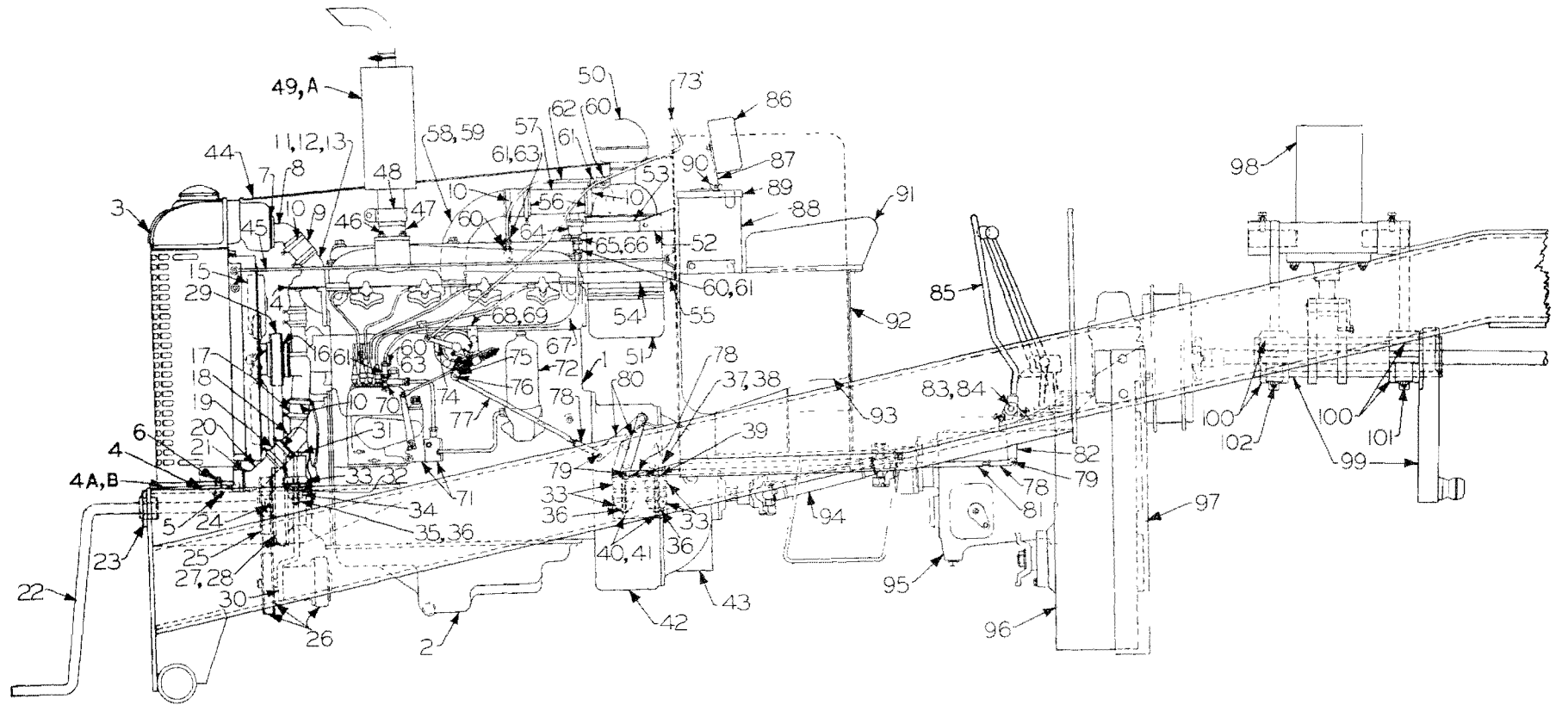

Refer to Pages 63, 64
and 65 for Part Numbers

B/M PGU-1910, A

Figure 42. UD-14A Diesel Engine and Accessories

REF. NO.	PART NO.	QUANTITY	DESCRIPTION
1	PGF-9316	1	Engine - UD-14A
2	IHC-59912-DM	1	Engine oil pan
3		1	Radiator
4	PGF-5235	2	Radiator pad
4A	PGF-10247	1	Radiator air shield (regular-first used on machine H-322)
4B	PGF-10606	1	Radiator air shield (special for machines with conveyor loader)
5	PGF-7647	2	Cap screw
6	737007	2	Slotted nut
7	PGF-4043	1	Gasket
8	PG-1699	1	Inlet elbow
9	PGF-9953	1	Hose
10	O34016	10	Hose clamp
11	PG-1799	1	Thermostat housing
12	IHC-250670R91	1	Thermostat (inside Ref. No. 11)
13	IHC-254753R1	1	Thermostat seal (inside Ref. No. 11)
14	IHC-50273-DB	1	Thermostat housing gasket
15	IHC-21259-D	1	Fan blade group
16	IHC-54857-DA	1	Generator belt
17	PGF-5691	1	Hose
18	PG-1698	1	Pipe
19	PGF-5692	1	Hose
20	PG-1772	1	Outlet elbow
21	PGF-4045	1	Gasket
22	PGF-9380	1	Crank
23	PGF-9381	1	Crank support
24	IHC-10319-D	1	Crankshaft pin
25	PG-1074	1	Pump drive pulley
26		1	Pump, pulley and belt (see hyd. pump page)
27	IHC-8120-DA	1	Fan drive pulley
28	IHC-47490-D	2	Fan drive pulley dowel pin
29	PGF-3062	1	Fan drive belt
30	PGF-9943	1	Engine support
31	PGF-9915	2	Engine support bolt
32	PGF-9917	2	Cushion spacer
33	PGF-9900	10	Cushion
34	PGF-6114	2	Engine support rebound
35	PGF-5909	2	Washer
36	727005	6	Castellated nut
37	PGF-9890	1	Engine support-right hand
38	PGF-9897	1	Engine support-left hand
39	PGF-5909	4	Washer
40	PGF-9932	4	Engine support bolt
41	PGF-9931	4	Cushion spacer
42		1	Flywheel housing
43		1	Clutch bell housing
44	PGF-9920	1	Hood
	PGF-9902	1	* Side door-left hand
	PGF-9919	1	* Side door-right hand
	PGF-597	2	* Side door fastener-long
	BRF-1546	2	* Side door fastener-short
	PGF-6932	2	* Side door fastener clip

Note: * Indicates parts not illustrated.

(continued)

(Refer to Figure 42 for Reference Numbers)

REF. NO.	PART NO.	QUANTITY	DESCRIPTION
45	PGF-8811	2	Brace
46	IHC-50677-D	4	Exhaust pipe stud
47	PGF-9053	1	Exhaust pipe
48	MGF-2950	1	Exhaust pipe clamp
49	PGF-3021	1	Muffler (1st type - 6" body diameter)
49A	PGF-10309	1	Muffler (2nd type - 7" body diameter)
50	PGF-9337	1	Pre-cleaner
51		1	Air cleaner (see air cleaner page)
52	PGF-9933	1	Air cleaner bracket support
53	PGF-9908	1	Air cleaner bracket-upper
54	PGF-9934	1	Air cleaner bracket-lower
55	PGF-9909	2	Cushion connector
56	PGF-9906	2	Air cleaner hose
57	PGF-9899	1	Air cleaner pipe
58	PGF-9901	1	Air cleaner pipe
59	IHC-50529-D	1	Air cleaner pipe gasket (engine end)
60	O34105	8	Hose clamp
61	PGF-7691	4	Hose
62	PGF-9488	1	Tube
63	PGF-7692	2	Air cleaner tube
64	IHC-64643-D	1	Injection pump air cleaner group
65	526001	1	Reducer bushing
66	PGF-7693	1	Air connection pipe
67	PGF-9489	1	Air cleaner tube
68	IHC-29538-D	1	Air cleaner tube clip
69	IHC-251112R1	1	Air cleaner tube clip felt
70	IHC-38026-DMX	1	Air cleaner tube connector (per GPS-201)
71	IHC	1	Fuel injection pump complete with transfer pump
72	IHC	1	Fuel filter
73	PGF-10130	1	Trip rod
74	PG-1362	1	Lever
75	PG-1790	1	Governor control lever
76	783005	1	Rod end pin
77	PGF-9298	1	Governor control rod
78	AJF-644	3	Rod end fork
79	AJF-616	3	Pin
80	PGF-10377	1	Governor control bracket
81	PGF-9299	1	Governor control rod
82	PG-1417	1	Governor control lever
83	PGF-10170	1	Governor control lever support bolt
84	NES-1652	1	Washer
85	PGF-10368	1	Governor control handle
86	PGF-5652	1	Rest back
87	PGF-10111	2	Rest back support
88	PGF-10124	1	Tool and battery box
89	PGF-10125	1	Tool and battery box cover
90	740003	2	Cover wing nut
91	PGF-9757	1	Seat cushion
92	PGF-10114	1	Cab tie plate
93		1	Fuel tank
	PGF-10121	2	Fuel tank belt-side (not illustrated)
	PGF-9918	2	Fuel tank belt-front (not illustrated)

(continued)

(Refer to Figure 42 for Reference Numbers)

REF. NO.	PART NO.	QUANTITY	DESCRIPTION
94	PGF-9079	1	Propeller shaft-clutch to transmission
95		1	Transmission
96		1	Transfer case
97	PGF-9286	1	Transfer case guard
98		1	High lift ram
99	PGF-9234	1	High lift shaft and arm
100		2	High lift shaft bearing (upper and lower halves)
101	AJF-3100	2	High lift shaft front bearing stud
102	PGF-10234	2	High lift shaft rear bearing stud
	PGF-8458	1	* Choke control wire
	IHC-50893-D	1	* Water pump bolt
	IHC-20586-D	1	* Cross shaft operating lever pin

Note: * Indicates parts not illustrated.

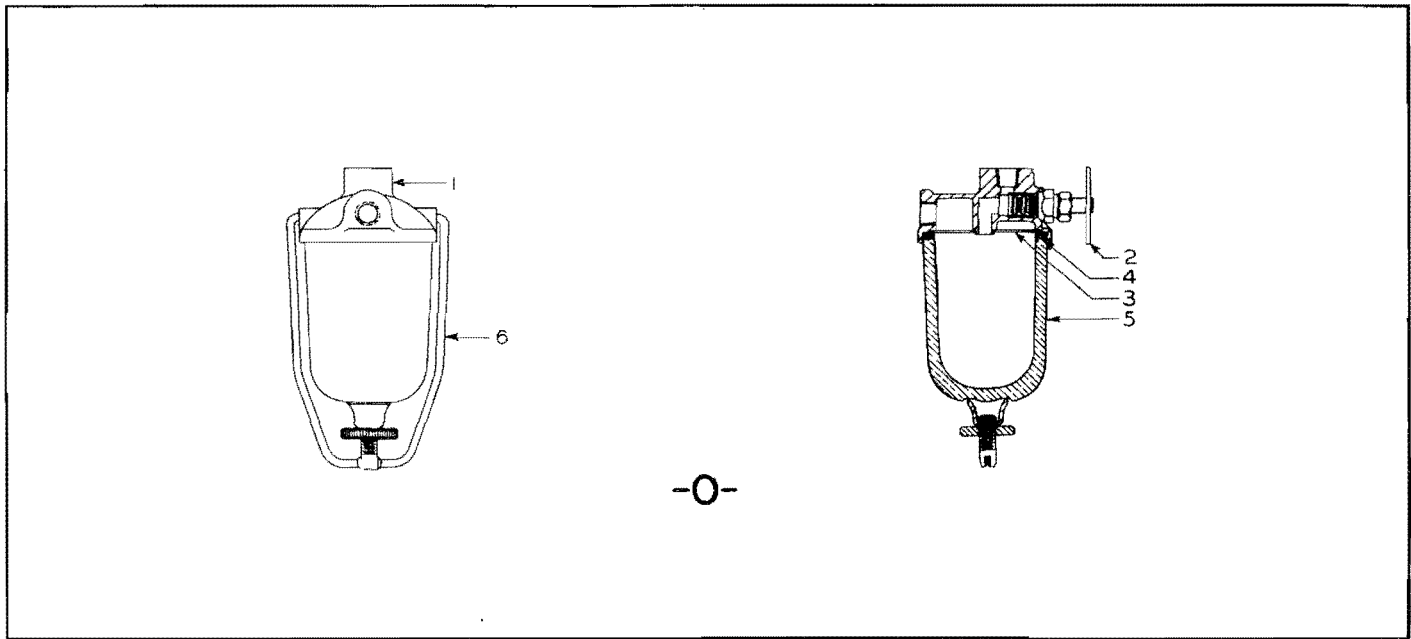
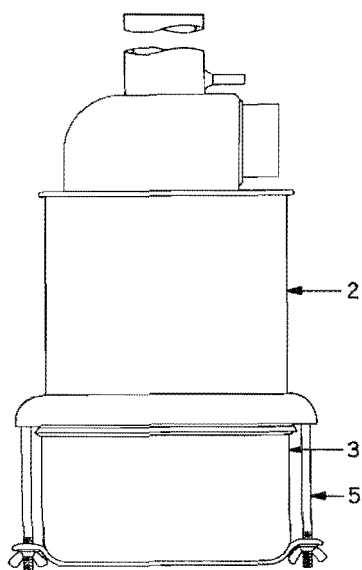

Figure 43. Gas Strainer for UD-14A Engine

REF. NO.	PART NO.	QUANTITY	DESCRIPTION
0	PGF-9336	1	Gas strainer, complete (includes Ref. Nos. 1 to 6 inclusive)
1	TMCO-OW-355	1	Cover
2	TMCO-OW-432	1	Shut-off cock
3	TMCO-OW-352	1	Screen
4	TMCO-OW-222	1	Gasket
5	TMCO-OW-304	1	Bowl
6	TMCO-OW-445	1	Clamp assembly



-1-

Figure 44. Air Cleaner
for UD-14A Engine
(Side rod type)

REF. NO.	PART NO.	QUANTITY	DESCRIPTION
1	PGF-8139	1	Air cleaner group (includes Ref. Nos. 2 to 5 incl.) (no longer furnished. Order PGF-9912 air cleaner shown below)
2	DC-P-5736	1	Body group
3	DC-P-3516	1	Oil cup group
4	DC-P-4886	1	* Housed screen and baffle group
5	DC-P-1517	2	Side rod group

Note: * Indicates part not illustrated.

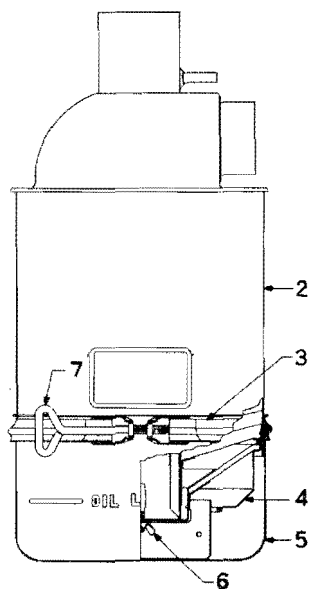

-1-

Figure 45. Air Cleaner
for UD-14A Engine
(Clamp ring type)

REF. NO.	PART NO.	QUANTITY	DESCRIPTION
1	PGF-9912	1	Air cleaner group (includes Ref. Nos. 2 to 5 incl.)
2	DC-P-7831	1	Body group (includes Ref. No. 6)
3	DC-P-6834	1	Oil cup retaining clamp group (includes Ref. No. 7)
4	DC-P-7048	1	Tray group
5	DC-P-7059	1	Oil cup group
6	DC-P-2247	2	Wing nut
7	DC-P-5653	1	Clamp bolt

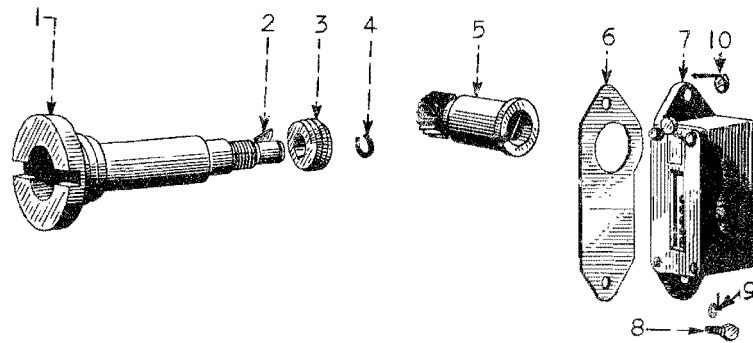

O-OA

Figure 46. Hourmeter for UD-14A Engine

REF. NO.	PART NO.	QUANTITY	DESCRIPTION
0	PGUS-9210	1	* Hourmeter group-special order (includes Ref. Nos. 1 to 10 inclusive)
OA	PGUS-9211	1	‡ Hourmeter group-special order (includes Ref. Nos. 2 to 10 inclusive)
1	IHC-51774-D	1	Magneto drive shaft
2	111001	1	Drive gear key
3	PGF-10181	1	Drive gear
4	PGF-10199	1	Drive gear retainer
5	PGF-10196	1	Driven gear, complete
6	PGF-10197	1	Gasket
7	PGF-10195	1	Hourmeter
8	PGF-10200	2	Cap screw
9	778009	2	Lock washer
10	PGF-10198	1	Lead seal

Note: * Indicates used on engines numbered 20669 and below.
 ‡ Indicates used on engines numbered 20670 and up.

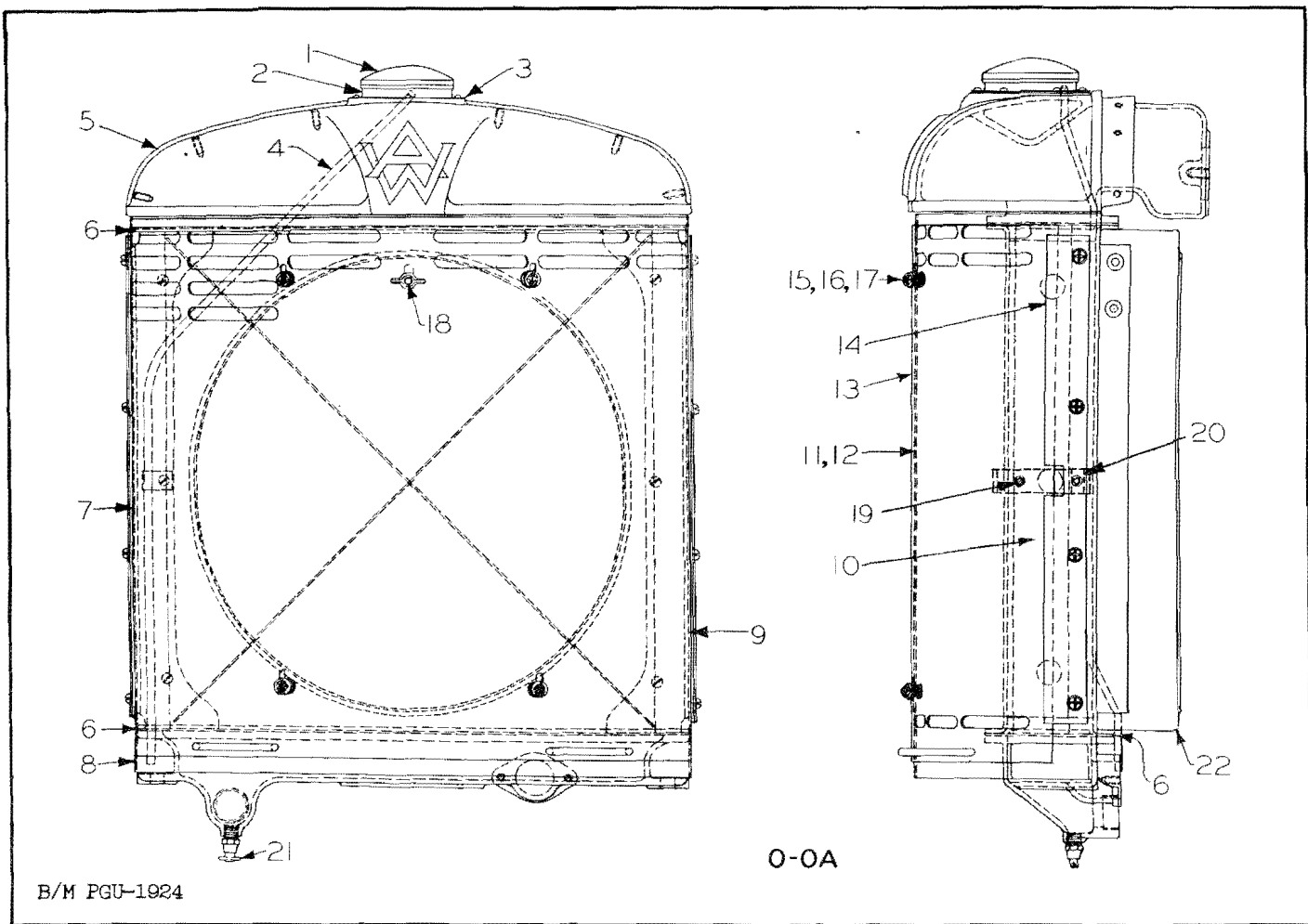
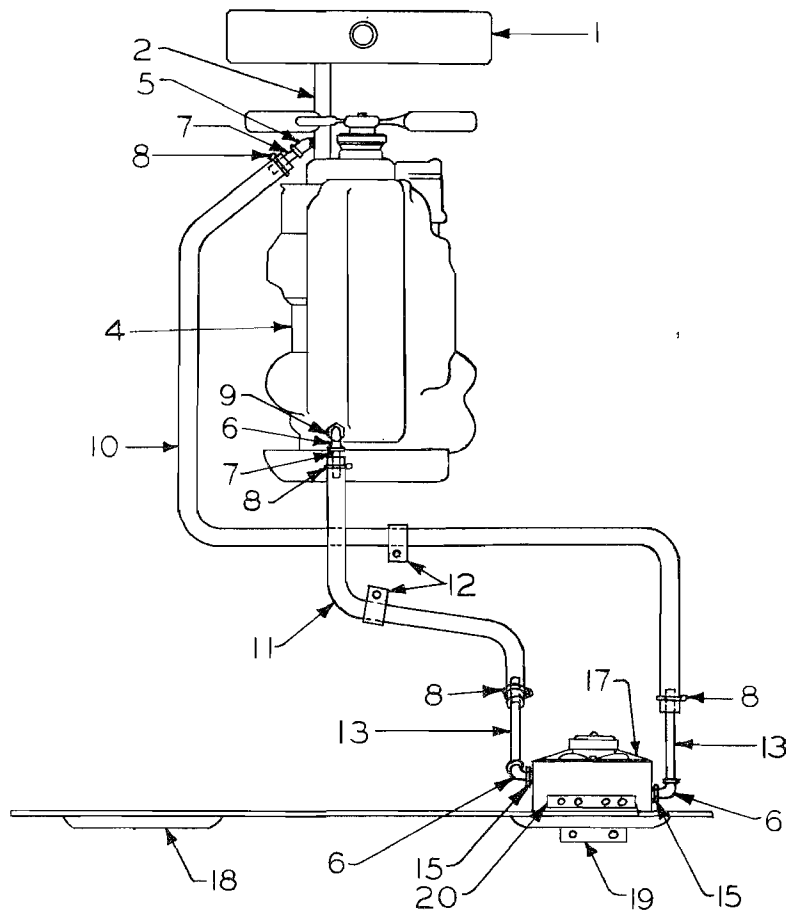

Figure 47. Radiator and Shutter for UD-14A Engine

REF. NO.	PART NO.	QUANTITY	DESCRIPTION
0	PGF-10248	1	Radiator group (includes Ref. Nos. 1 to 11 inclusive)
OA	PGU-1924	1	Radiator shutter group (special order) (includes Ref. Nos. 13 to 20 inclusive)
1	YRC-25025	1	Cap
2	YRC-30517	1	Neck
3	YRC-28268	1	Neck gasket
4	YRC-44459	1	Overflow tube
5	YRC-49484	1	Top tank
6	YRC-25032	2	Gasket
7	YRC-49487	1	Side member-left hand
8	YRC-24825-B	1	Bottom tank
9	YRC-49486	1	Side member-right hand
10	PGF-10248-2	1	Core with gaskets (includes Ref. No. 6)
11	YRC-56902	1	Grille-standard
12	PGF-10362	1	Grille-special for shutter
13	PGF-10361	1	Shutter
14	PGF-10363	2	Side strip
15	PGF-7638	4	Spring bolt
16	PGF-6505	4	Spring
17	727001	4	Castellated nut
18	740003	1	Wing nut
19	PGF-10777	2	Spacer-round
20	PGF-10776	2	Spacer-flat
21	PGF-9339	1	Drain cock
22	PGF-10252	1	Fan shroud



B/M PGU-1826-B

Figure 48. Heater Piping Diagram for UD-14A Engine

REF. NO.	PART NO.	QUANTITY	DESCRIPTION
1		1	Radiator
2		1	Outlet elbow
4		1	Engine
5	564051	1	Elbow
6	563852	3	Elbow
7	556101	2	Pipe
8	034010	4	Hose clamp
9	534006	1	Reducer bushing
10	PGF-10132	1	Heater hose
11	PGF-10131	1	Heater hose
12	PGF-9960	2	Hose clip
13	556121	2	Pipe
15	884008	2	Reducer bushing
17	PGF-8924	1	Heater
18	PGF-10114	1	Cab tie plate
19	PGF-10113	1	Heater support plate
20	PGF-10129	1	Support plate angle

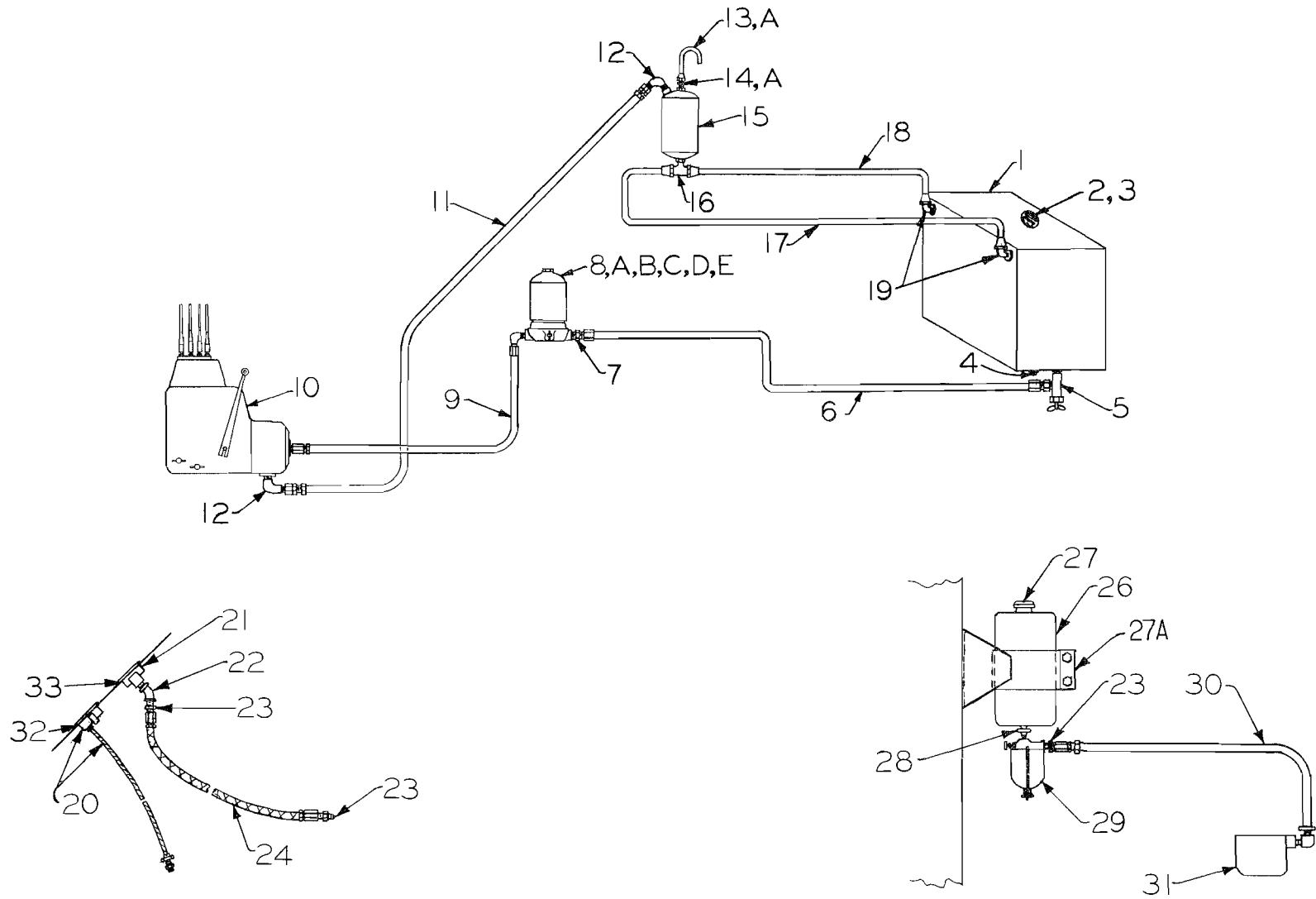
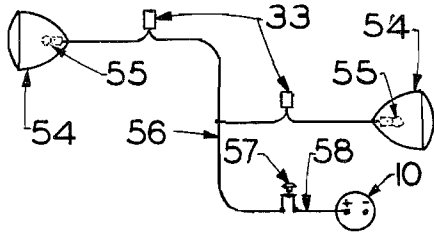

Figure 49. Fuel System for UD-14A Engine

REF. NO.	PART NO.	QUANTITY	DESCRIPTION
1	PGF-10112	1	Fuel tank
2	PG-1773	1	Fuel tank cap
3	PGF-9275	1	Gasket
4	816003	1	Drain plug
5	PGF-9338	1	Needle valve
6	PGF-9491	1	Fuel hose
7	840006	1	Connector
8	IHC	1	Fuel filter
8A	IHC-250337R1	1	Fuel filter element spring
8B	IHC-250336R1	1	Fuel filter top plate seal ring
8C	IHC-250335R11	1	Fuel filter top plate
8D	IHC-250332R91	1	Fuel filter element
8E	IHC-251209R11	1	Fuel filter screen
9	IHC-253424R11	1	Fuel pipe
10	IHC-65314-D101	1	* Fuel injection pump complete with transfer pump
11	PGF-10334	1	Fuel hose-return line
12	835006	2	Elbow
13	PGF-10335	1	Breather "U" tube - 1/4" OD (no longer furnished. Order Ref. Nos. 13A and 14A)
13A	PGF-10492	1	Breather "U" tube - 5/16" OD
14	840003	1	Connector (used with PGF-10335 "U" tube)
14A	840005	1	Connector (used with PGF-10492 "U" tube)
15	PGF-10330	1	Breather tank
16	830004	1	Tee
17	PGF-10333	1	Breather tube-long
18	PGF-10332	1	Breather tube-short
19	835007	2	Elbow
20	PGF-9549	1	Water temperature gauge
21	TF-1530	1	Oil pressure gauge
22	568001	1	Elbow
23	840005	3	Connector
24	PGF-9490	1	Oil gauge hose
26	PGF-4057	1	Gas tank
27	GC-745	1	Gas tank cap
27A	PGF-8981	1	Gas tank support
28	PGF-5756	1	Adapter
29	PGF-9336	1	Gas strainer
30	PGF-9886	1	Gas hose
31	IHC-252468R91	1	Carburetor (per GPS-109-A)
32	PGF-9280	1	Water temperature gauge gasket
33	PGF-9281	1	Oil pressure gauge gasket

Note: * When ordering a replacement pump from IHC be sure to give the pump part number stamped on the name plate attached to the pump. With this information IHC will be able to supply a pump set at the proper governed speed.



Wiring for warning lights

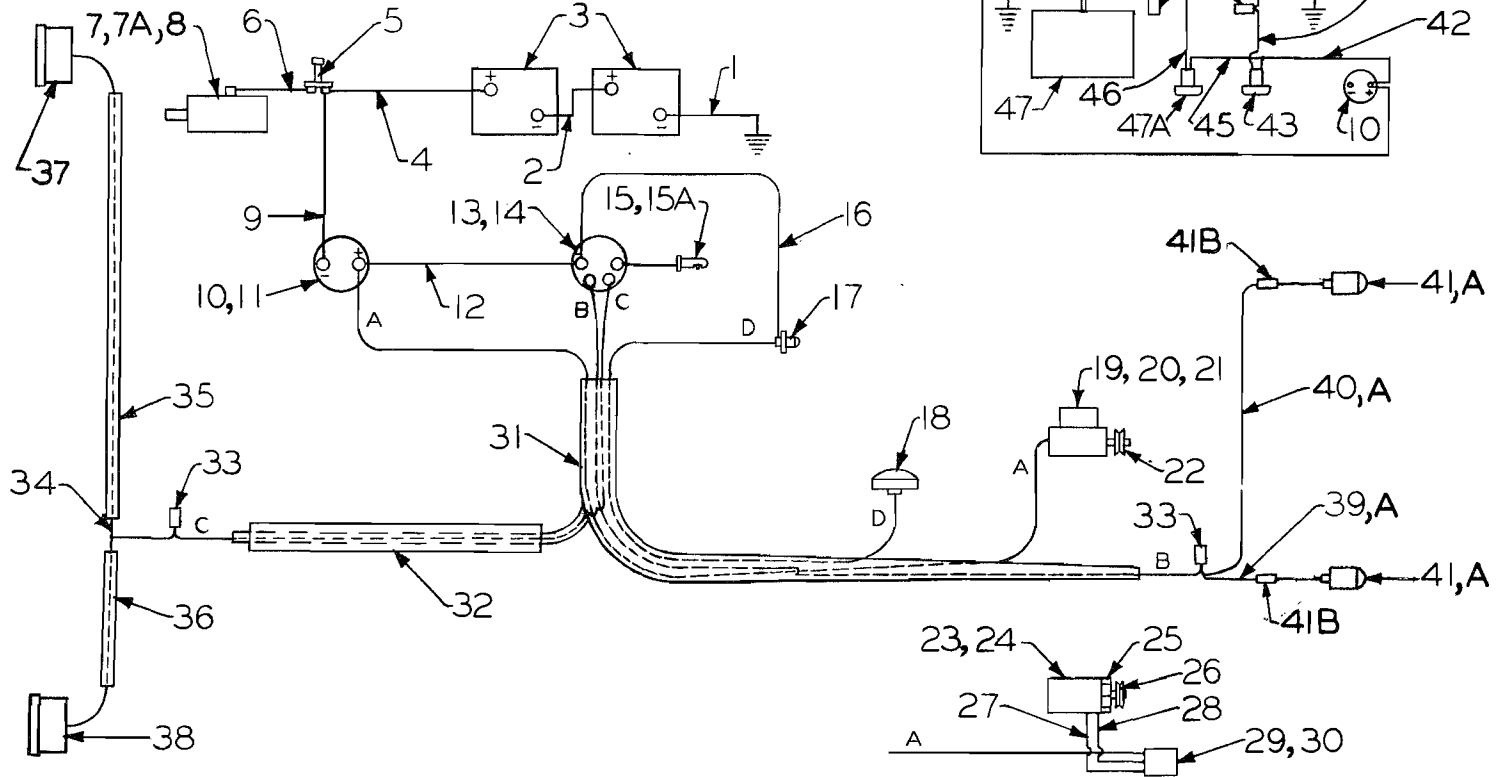
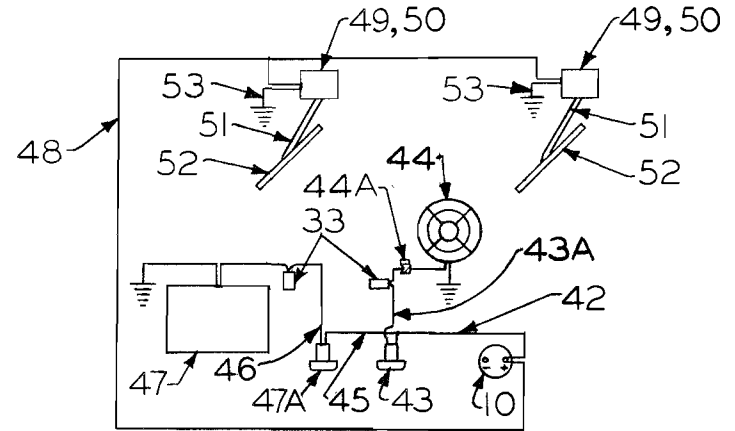

Wiring for heavy duty generator

Refer to Pages 73 and 74 for Part Numbers

Figure 50. Wiring Diagram for UD-14A Engine

B/M PGU-1824, 1826-B, 1828, 1833
PGU-1833-A, 1858, 1893, 1943

REF. NO.	PART NO.	QUANTITY	DESCRIPTION
1	PGF-10117	1	Cable-battery to ground
2	PGF-10118	1	Cable-jumper
3	PGF-10122	2	Battery - 6 volt (19 plate)
	PGF-10115	1	Battery clamp (not illustrated)
	PGF-10123	3	Battery clamp stud (not illustrated)
4	PGF-10119	1	Cable-battery to starter switch
5	PGF-9350	1	Starter switch
6	AJF-2772	1	Cable-starter switch to starter
7	PGF-9798	1	Starting motor (Delco-Remy No. 1109106) (no longer furnished. Order Ref. No. 7A)
7A	PGF-10700	1	Starting motor (Delco-Remy No. X-10146)
8	IHC-58220-DX	1	Starting motor shield (per GPS-201)
9	PGF-9508	1	Wire-starter switch to ammeter
10	PGF-9349	1	Ammeter
11	PGF-9282	1	Ammeter gasket
12	PGF-9506	1	Wire-ammeter to light and ignition switch
13	PGF-9351	1	Light and ignition switch
14	PGF-9279	1	Switch gasket
15	ASF-5372	1	Dash light
15A	GES-67	1	Dash light bulb - 3CP
16	PGF-9547	1	Wire-switch to horn button
17	PGF-9343	1	Horn button
18	PGF-9342	1	Horn
19	PGF-9352	1	Generator (standard) (Delco-Remy No. 1101738)
20	IHC-50891-D	1	Generator bracket
21	IHC-50892-DA	1	Generator brace
22	IHC-8081-D	1	Generator pulley
23	PGF-9354	1	Generator (special-heavy duty) (Delco-Remy No. 1102955)
24	PGF-5161	1	Generator support
25	PGF-9357	1	Generator fan
26	PGF-9356	1	Generator pulley
27	PGF-5162	1	Wire-generator to regulator
28	PGF-5163	1	Wire-generator to regulator
29	PGF-9355	1	Voltage regulator (Delco-Remy No. 1118209)
30	PGF-5160	1	Regulator support
31	PGF-9518	1	Wiring harness assembly
32	PGF-9955	1	Loom
33	PGF-9966	6	Connector
34	PGF-10028	1	Wire-connector to headlights
35	PGF-10027	1	Loom to right hand headlight
36	PGF-10026	1	Loom to left hand headlight
37	PGF-9359	1	Headlight-right hand
38	PGF-9360	1	Headlight-left hand
39	PGF-9499	1	Wire-connector to left hand tail light (used with PGF-9341 tail light)
39A	PGF-10747	1	Wire-connector to left hand tail light connector (used with PGF-10727 tail light)
40	PGF-9498	1	Wire-connector to right hand tail light (used with PGF-9341 tail light)
40A	PGF-10746	1	Wire-connector to right hand tail light connector (used with PGF-10727 tail light)
41	PGF-9341	2	Tail light (uses plug connector at lamp)
41A	PGF-10727	2	Tail light (uses sleeve connector on wire)
41B	PGF-10421	2	Connector (used with PGF-10727 tail light)
42	PGF-10135	1	Wire-ammeter to defroster switch
43	PGF-10085	1	Defroster switch
43A	PGF-10080	1	Wire-connector to defroster switch
44	PGF-10034	1	Defroster fan
44A	PGF-10045	1	Defroster wire clip
45	PGF-9963	1	Wire-defroster switch to heater switch
46	PGF-10136	1	Wire-connector to heater switch
47		1	Heater (see heater page)
47A		1	Heater switch
48	PGF-9965	1	Wire-ammeter to windshield wipers
49	PGF-9796	2	Windshield wiper
50	PGF-10047	2	Windshield wiper spacer

(continued)

(Refer to Figure 50 for Reference Numbers)

REF. NO.	PART NO.	QUANTITY	DESCRIPTION
51	PGF-9799	2	Windshield wiper arm
52	PGF-9797	2	Windshield wiper blade
53	PGF-9961	2	Wire-windshield wiper to ground
54	PGF-10629	2	Warning light (special order)
55	PGF-10632	2	Light bulb
56	PGF-10628	1	Wire-switch to connectors
57	ASF-3882	1	Warning light switch
58	PGF-10135	1	Wire-ammeter to switch

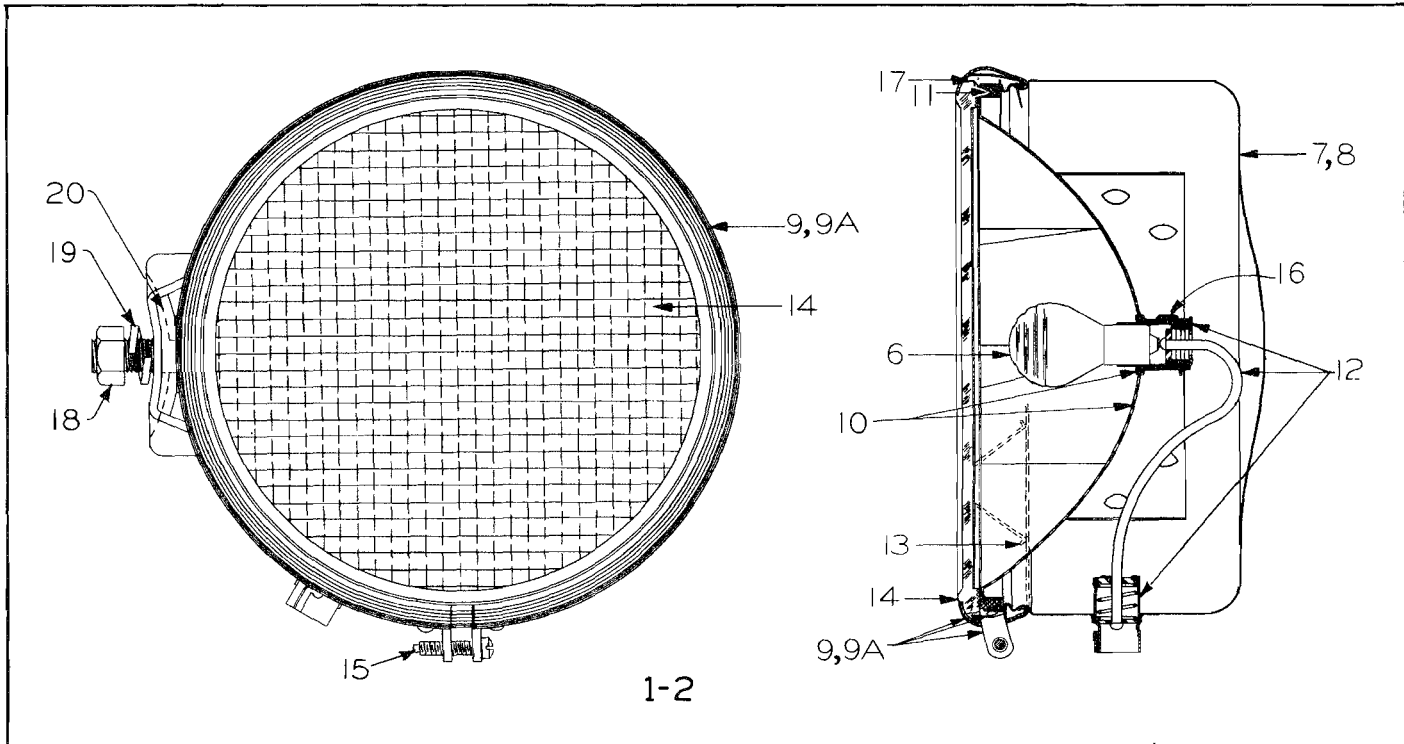

Figure 51. Headlights

REF. NO.	PART NO.	QUANTITY	DESCRIPTION
1	PGF-9360	1	Headlight-left hand (shown)
2	PGF-9359	1	Headlight-right hand (opposite)
6	GLCO-142454	1	Bulb (15 CP - SC - 12-16 V)
7	GLCO-914525	1	Body (for Ref. No. 1)
8	GLCO-914526	1	Body (for Ref. No. 2)
9	GLCO-914529	1	Molding group-with lens
9A	GLCO-914531	1	Molding group-no lens
10	GLCO-914533	1	Reflector group
11	GLCO-914535	1	Washer group
12	GLCO-914537	1	Wiring group
13	GLCO-914255	2	Lens retaining spring
14	GLCO-914530	1	Lens
15	GLCO-912711	1	Molding screw
16	GLCO-913447	1	Socket retaining spring
17	GLCO-913220	1	Lens locator clip
18	GLCO-120371	1	Support bolt nut
19	GLCO-103323	1	Lock washer
20	GLCO-912206	1	Bearing washer
	PGF-10324	1	Headlight plug (not illustrated)

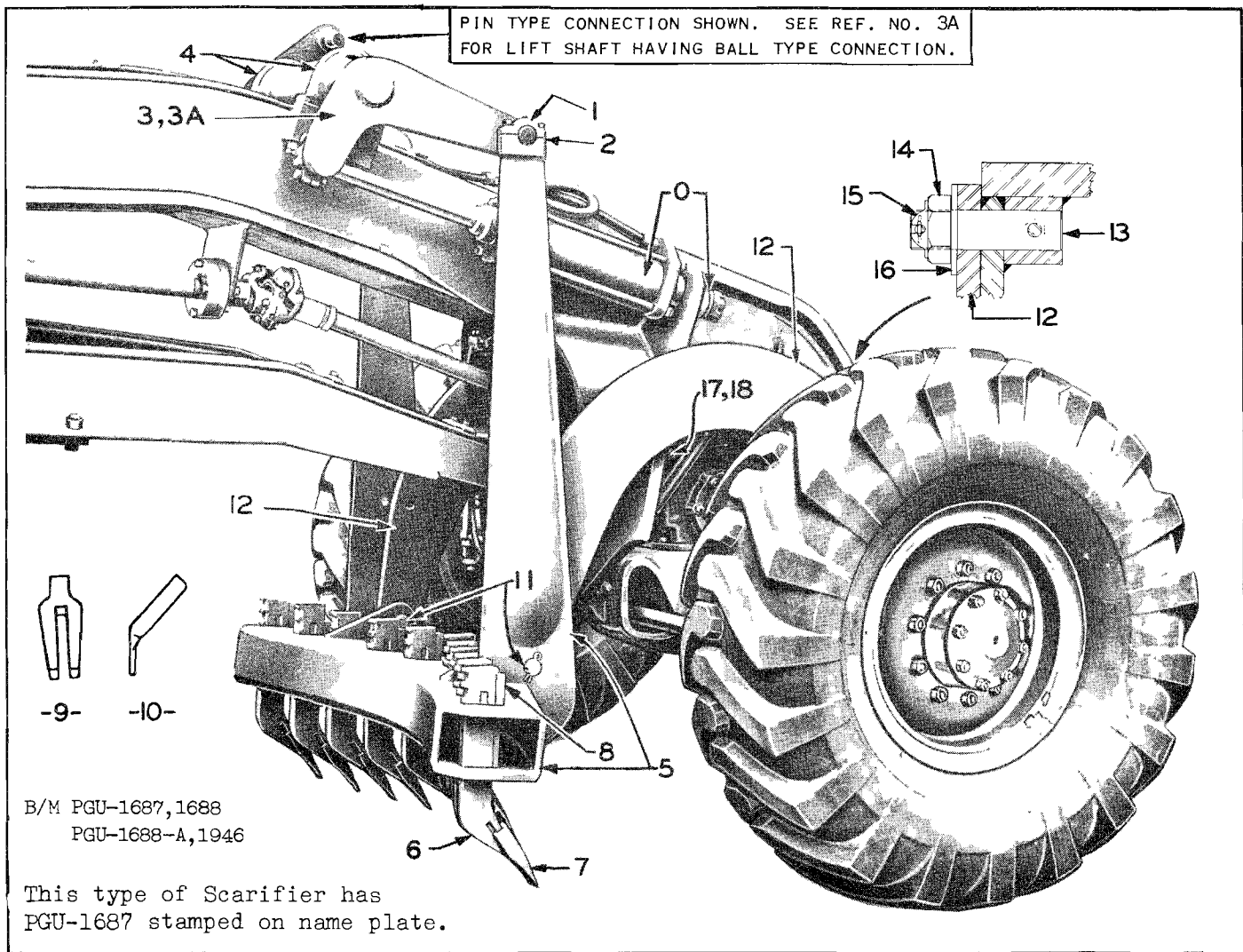
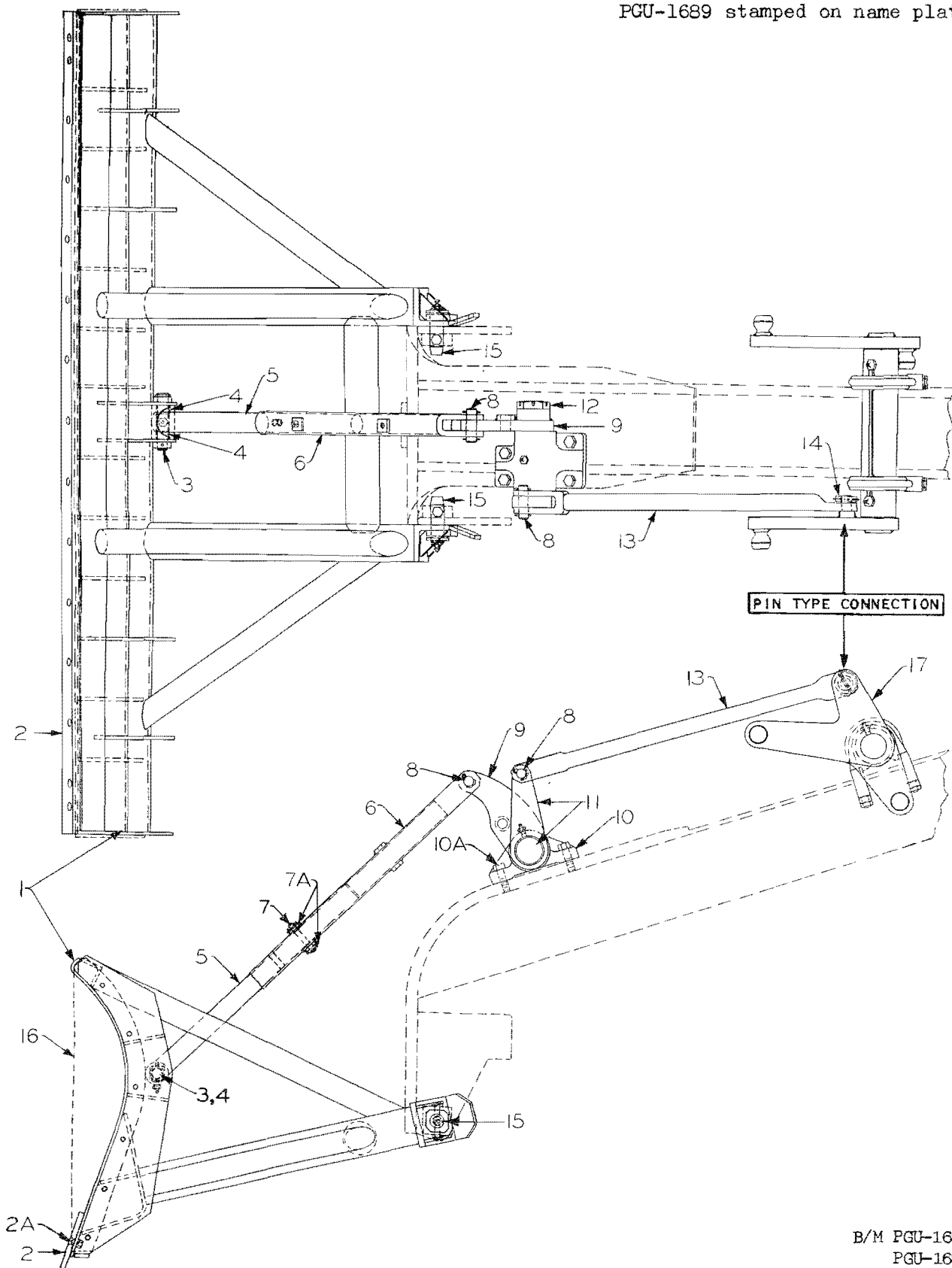

Figure 52. Scarifier

REF. NO.	PART NO.	QUANTITY	DESCRIPTION
0		1	Scarifier ram group (see other pages)
1	PGF-9487	2	Ball cap
2	MGF-1992	8	Shim
3	PGF-9693	1	Lift shaft (has welded pin for bulldozer and snow plow control)
3A	PGF-10712	1	Lift shaft (has welded ball for bulldozer and snow plow control)
4	PGF-8390	2	"U" bolt
5	PGF-9790	1	Block
6	PGF-5375	11	Tooth shank
7	PGF-5376	11	Tooth point
8	PGF-3579	11	Tooth wedge
9	PGF-5698	1	Tooth point remover
10	MGF-2454	1	Tooth wedge remover
11	PGF-9049	2	Pin
12	PGF-9627	2	Arm
13	PGF-6640	2	Pin
14	PGF-5405	2	Nut
15	PGF-7191	2	Nut clip
16	MGF-1185	2	Washer
17	PGF-9695	1	* Arm latch-right hand
18	PGF-9694	1	* Arm latch-left hand

Note: * Indicates parts used when machine is equipped with a bulldozer or snow plow in addition to scarifier.

This type of Bulldozer has
PGU-1689 stamped on name plate.



B/M PGU-1688, A
PGU-1689
PGU-1807

Figure 53. Bulldozer (1st type)

REF. NO.	PART NO.	QUANTITY	DESCRIPTION
1	PGU-1809	1	Blade assembly with bit (inc. Ref. Nos. 2 & 2A)
2	PGF-9556	1	Bit - 5/8" x 8" x 9"
2A	RGF-6461	15	Bit bolt
3	PGF-9564	1	Pin
4	PGF-9563	2	Bushing
5	PGF-9689	1	Lift rod
6	PGF-9690	1	Lift tube
7	SPF-1085	1	Pin
7A	PGF-10644	2	Washer
8	PGF-9562	2	Pin
9	PGF-9656	1	Arm
10	PG-1815	1	Support
10A	741884	4	Cap screw
11	PGF-9692	1	Lift shaft
12	PG-728	1	Nut
13	PGF-9696	1	Connecting rod (pin type connection)
14	PGF-9566	1	Collar
15	PGF-10736	2	Pivot pin
16	PGF-9567	2	Blade landside (special order)
17	PGF-9693	1	Scarifier lift shaft

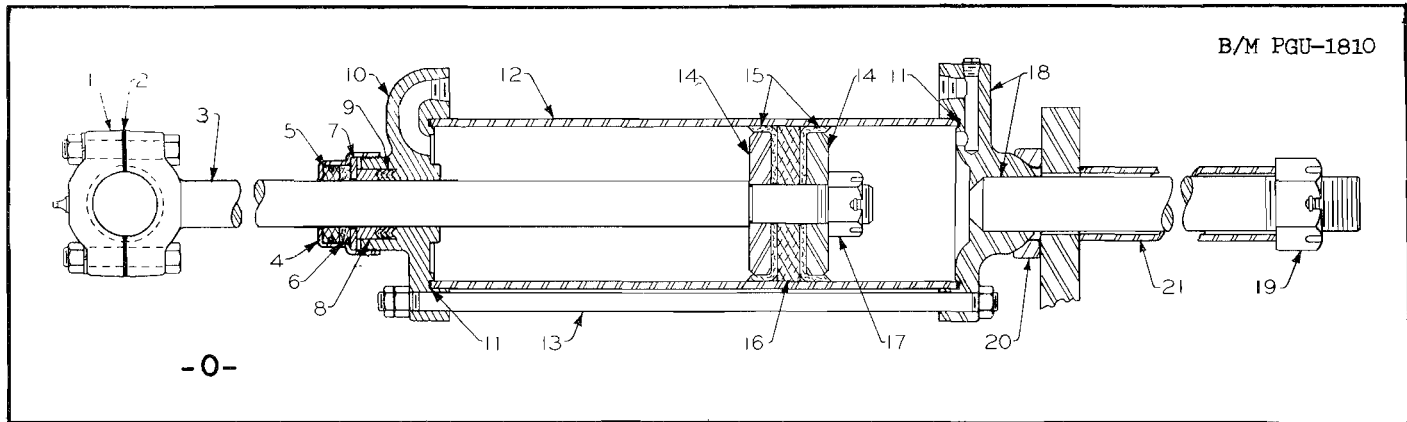
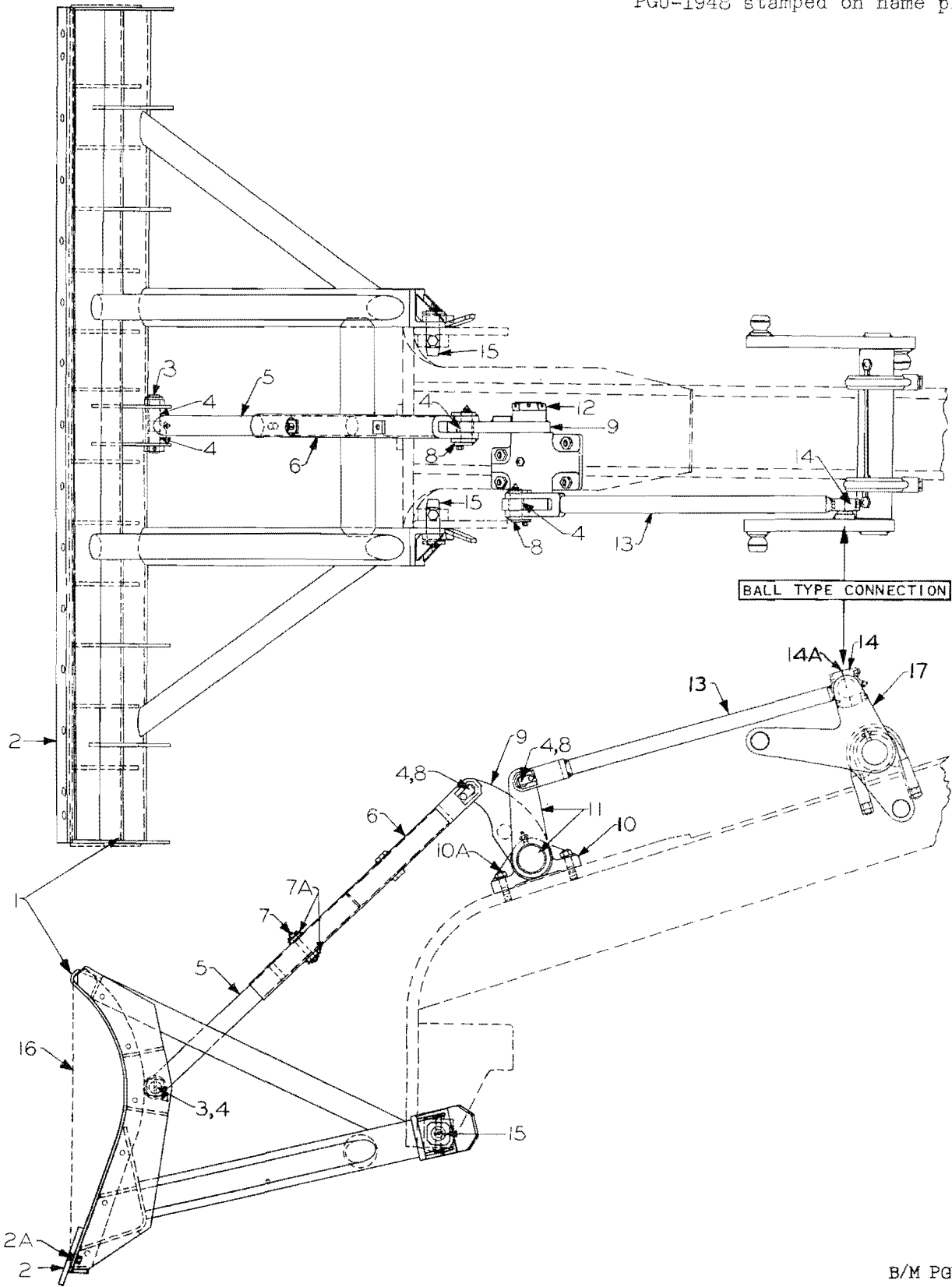

Figure 54. Scarifier Ram (1st type)
(Also used with Bulldozer and front Snow Plows)

REF. NO.	PART NO.	QUANTITY	DESCRIPTION
0	PGU-1810	1	Ram group (no longer furnished. Order PGU-1810-A scarifier ram group, 1, PG-1709 socket and 1, PG-1926 ball plate)
1	PGF-9487	1	Cap
2	MGF-1992	6	Shin.
3	PGF-7884	1	Piston rod
4	PGF-7019	1	Cap
5	PGF-1699	1	Wiper
6	PGF-6997	1	Felt
7	PGF-7025	1	Retainer
8	PG-1348	1	Press ring
9	RGF-4382	4	Chevron packing ring
10	PG-1458	1	Head
11	PGF-1688	2	Gasket
12	PGF-7857	1	Cylinder
13	PGF-7858	4	Tie rod
14	PGF-3255	2	Spreader
15	PGF-5590	2	Cup
16	PG-862	1	Piston
17	734013	1	Slotted nut
18	PGX-8777	1	Base with shaft (no longer furnished. Order PGX-10699 base, 1, PG-1709 socket and 1, PG-1926 ball plate)
19	PGF-6641	1	Nut
20	PG-1709	1	Socket
21	PGF-9792	1	Spacer

This type of Bulldozer has
PGU-1948 stamped on name plate.



B/M PGU-1946
PGU-1947
PGU-1948

Figure 55. Bulldozer (2nd type)

REF. NO.	PART NO.	QUANTITY	DESCRIPTION
1	PGU-1949	1	Blade assembly with bit (inc. Ref. Nos. 2 & 2A)
2	PGF-9556	1	Bit - 5/8" x 8" x 9'
2A	RGF-6461	15	Bit bolt
3	PGF-10726	1	Pin
4	SPF-1100	4	Bushing
5	PGF-10733	1	Lift rod
6	PGF-10721	1	Lift tube
7	SPF-1085	1	Pin
7A	PGF-10644	2	Washer
8	PGF-10731	2	Pin
9	PGF-10734	1	Arm
10	PG-1815	1	Support
10A	PGF-10730	4	Stud
11	PGF-10732	1	Lift shaft
12	PG-728	1	Nut
13	PGF-10720	1	Connecting rod (ball type connection)
14	PGF-9487	1	Ball cap
14A	MGF-1992	6	Ball cap shim
15	PGF-10736	2	Pivot pin
16	PGF-9567	2	Blade landside (special order)
17	PGF-10712	1	Scarifier lift shaft

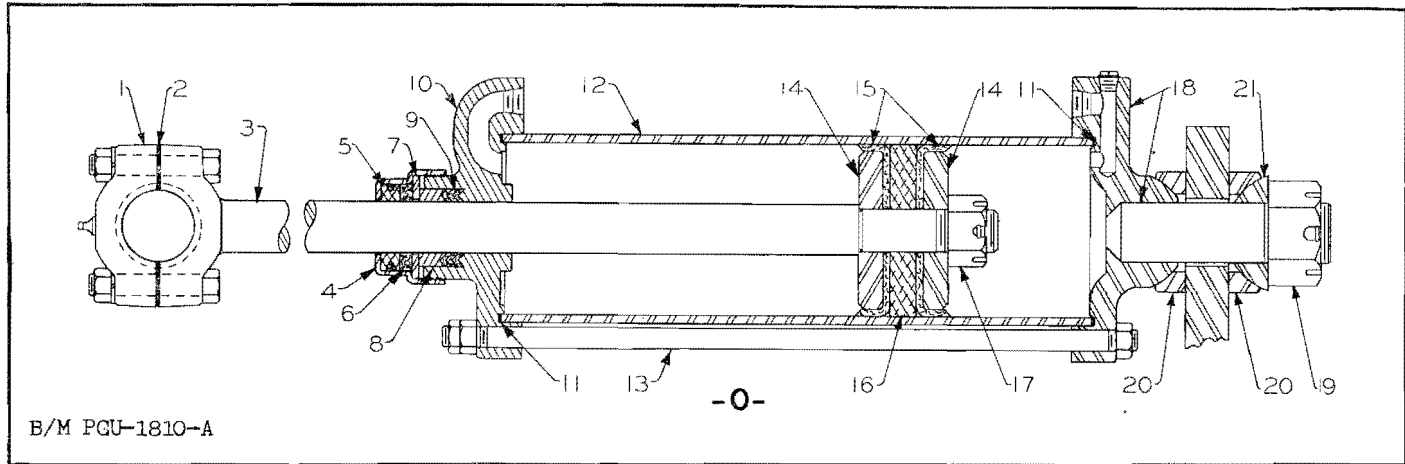
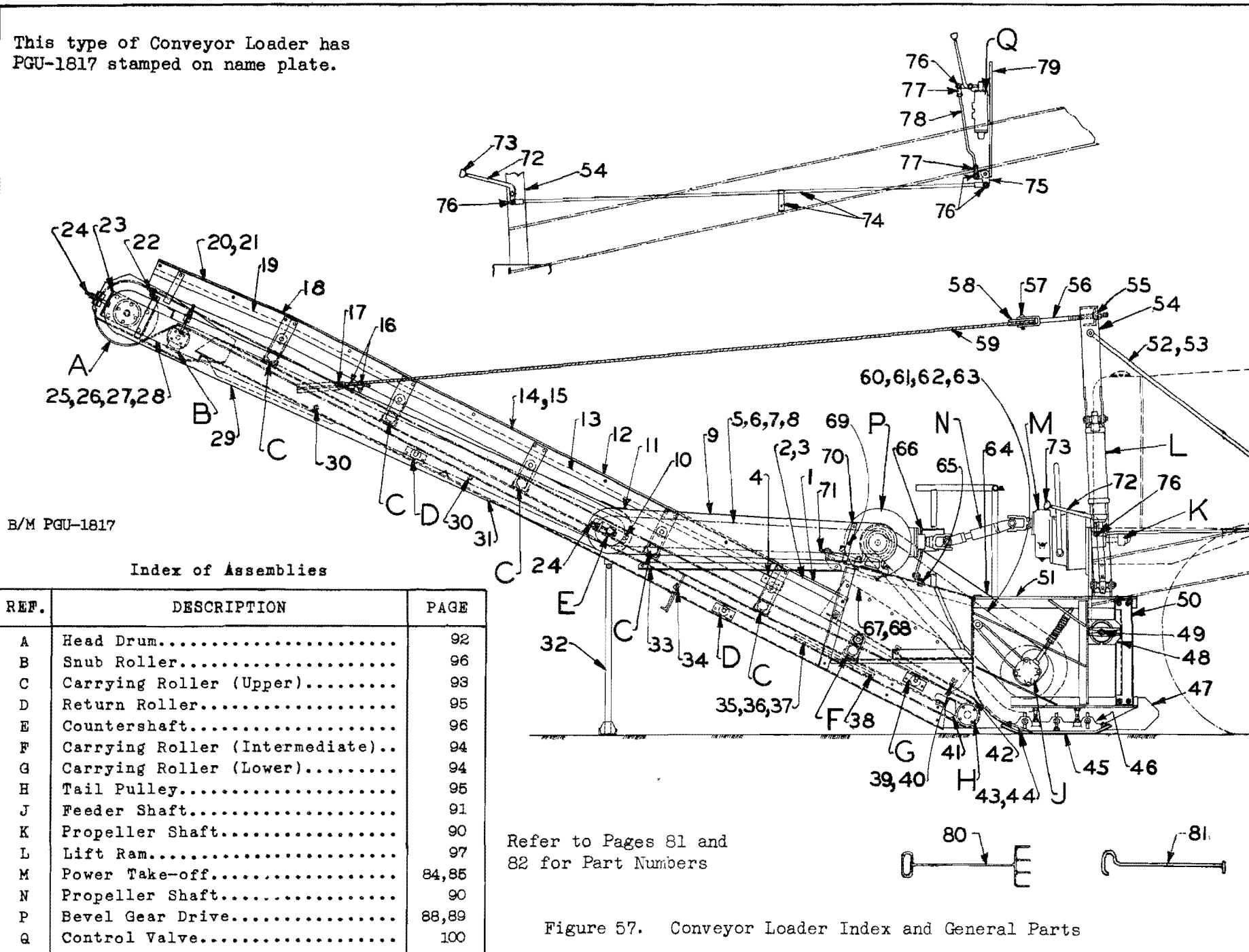

Figure 56. Scarifier Ram (2nd type)
 (Also used with Bulldozer and front Snow Plows)

REF. NO.	PART NO.	QUANTITY	DESCRIPTION
0	PGU-1810-A	1	Ram group (includes Ref. Nos. 1 to 18 incl.)
1	PGF-9487	1	Cap
2	MGF-1992	6	Shim
3	PGF-7884	1	Piston rod
4	PGF-7019	1	Cap
5	PGF-1699	1	Wiper
6	PGF-6997	1	Felt
7	PGF-7025	1	Retainer
8	PG-1348	1	Press ring
9	RGF-4382	4	Chevron packing ring
10	PG-1458	1	Head
11	PGF-1688	2	Gasket
12	PGF-7857	1	Cylinder
13	PGF-7858	4	Tie rod
14	PGF-3255	2	Spreader
15	PGF-5590	2	Cup
16	PG-862	1	Piston
17	734013	1	Slotted nut
18	PGX-10699	1	Base with shaft and nut, Ref. No. 19
19	PGF-6641	1	Nut
20	PG-1709	2	Socket
21	PG-1926	1	Ball plate (supersedes PGF-10694)

This type of Conveyor Loader has
PGU-1817 stamped on name plate.



B/M PGU-1817

Index of Assemblies

REF.	DESCRIPTION	PAGE
A	Head Drum.....	92
B	Snub Roller.....	96
C	Carrying Roller (Upper).....	93
D	Return Roller.....	95
E	Countershaft.....	96
F	Carrying Roller (Intermediate)..	94
G	Carrying Roller (Lower).....	94
H	Tail Pulley.....	95
J	Feeder Shaft.....	91
K	Propeller Shaft.....	90
L	Lift Ram.....	97
M	Power Take-off.....	84,85
N	Propeller Shaft.....	90
P	Bevel Gear Drive.....	88,89
Q	Control Valve.....	100

Refer to Pages 81 and
82 for Part Numbers

Figure 57. Conveyor Loader Index and General Parts

REF. NO.	PART NO.	QUANTITY	DESCRIPTION
1	PGF-6796	2	Flashing
2	PGF-6797	2	Backing strip-long (used on right and left side)
3	PGF-6798	2	Backing strip-short (used on right and left side)
4	PGF-8956	2	Flashing clip
5	PGF-9669	1	Conveyor drive chain (#434-143 pitches)
6	#434-1	1	Offset link (with pin and cotter)
7	#434-2	1	Connecting link (with pins and cotters)
8	#434-3	As req'd.	Roller link
9	PGF-9650	1	Lower chain guard
10	PGF-5474	1	Support
11	PGF-9651	1	Tie
12	PGF-9671	2	Flashing
13	PGF-9675	2	Strip
14	PGF-9673	1	Backing strip-right hand
15	PGF-9672	1	Backing strip-left hand
16	906004	4	Cable clamp
17	860005	2	Cable thimble
18	PGF-5621	2	Flashing
19	PGF-5620	2	Strip
20	PGF-5613	1	Backing strip-right hand
21	PGF-5614	1	Backing strip-left hand
22	PGF-9342	1	Horn
23	PGF-4941	2	Bearing plate
24	PGF-5619	4	Adjusting bolt
25	PGF-9667	1	Conveyor drive chain (#434-255 pitches)
26	#434-1	1	Offset link (with pin and cotter)
27	#434-2	1	Connecting link (with pins and cotters)
28	#434-3	As req'd.	Roller link
29	PGF-9676	1	Upper chain guard
30	PGF-5615	2	Spacer
31	PGF-9682	1	Frame
32	PGF-10108	1	Stand
33	PGF-9794	2	Brace
34		2	Tail light
35	PGU-1469	1	Belt scraper group (includes Ref. Nos. 36 and 37)
36	PGF-5355	1	Scraper frame
37	PGF-5356	1	Scraper frame belting
38	MGF-445	2	Bushing
39	PGF-6801	6	Flashing clip
40	PGF-6759	6	Flashing spacer
41	PGF-5424	1	Tail pulley scraper
42	PGF-6799	2	Flashing
43	PGF-6539	1	Bit - 3/8" x 12-5/8" x 4'-11-1/2"
44	RGF-6444	14	Bit bolt
45	PGF-6794	2	Runner shoe
46	PGA-1314	2	Runner
47	PGF-6804	2	Extension plate
48	PG-1321	2	Guide
49	PGF-5464	1	Tie rod
50	PGF-4926	4	Channel
51	PGF-9678	1	Scoop
52	PGF-9679	1	Brace-right hand
53	PGF-9680	1	Brace-left hand

(continued)

(Refer to Figure 57 for Reference Numbers)

REF. NO.	PART NO.	QUANTITY	DESCRIPTION
54	PGF-9674	1	Mast
55	PGF-1858	1	Pivot washer
56	PGF-9665	1	Pulley support
57	PGF-5321	1	Pin
58	WK-48	1	Pulley
59	PGF-9666	1	* Lift cable - 3/8" x 29'-6"
60	PGF-9668	1	Feeder drive chain (#470-89 pitches)
61	#470-1	1	Offset link (with pin and cotter)
62	#470-2	1	Connecting link (with pins and cotters)
63	#470-3	As req'd.	Roller link
64	PGF-9677	1	Feeder chain guard
65	PGF-5349	1	Support angle
66	PGF-9670	1	Support plate
67	PGF-6818	1	Dirt guard-right hand
68	PGF-6817	1	Dirt guard-left hand
69	PGF-5475	1	Spacer
70	PGF-9775	1	Support
71	PGF-5465	2	Eye bolt
72	PG-855	1	Valve lever
73	ASF-4604	1	Valve lever ball
74	PGF-9793	1	Valve control rod
75	PGF-9768	1	Valve control lever
76	783004	4	Rod end pin
77	782004	2	Rod end fork
78	PGF-9822	1	Control rod
79		1	Valve support plate
80	PGF-5347	1	Dirt poker
81	PGF-5743	1	Clean-out tool (tail pulley)

Note: * Indicates (6 x 19) improved plow steel, regular lay (right lay), independent wire rope center, filler wire seale, non-preformed.

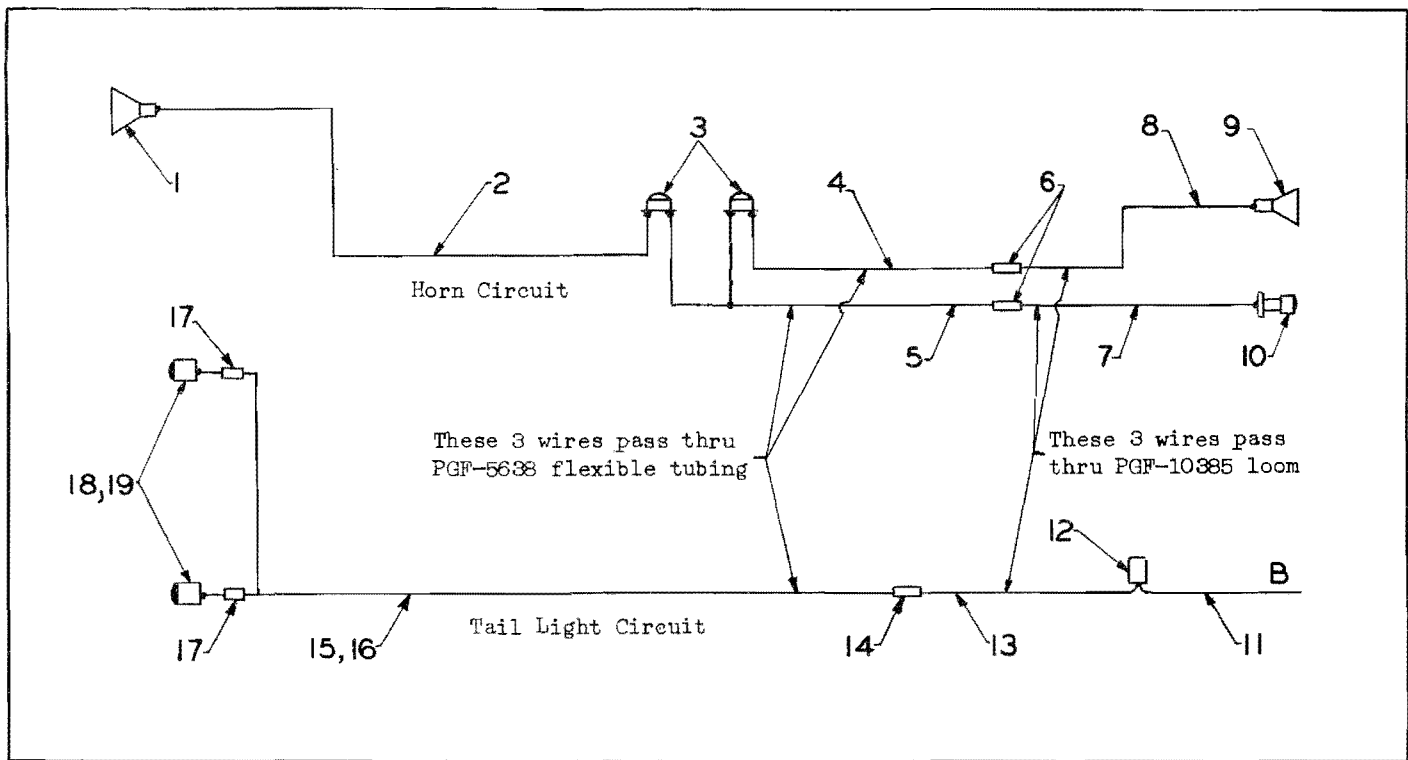
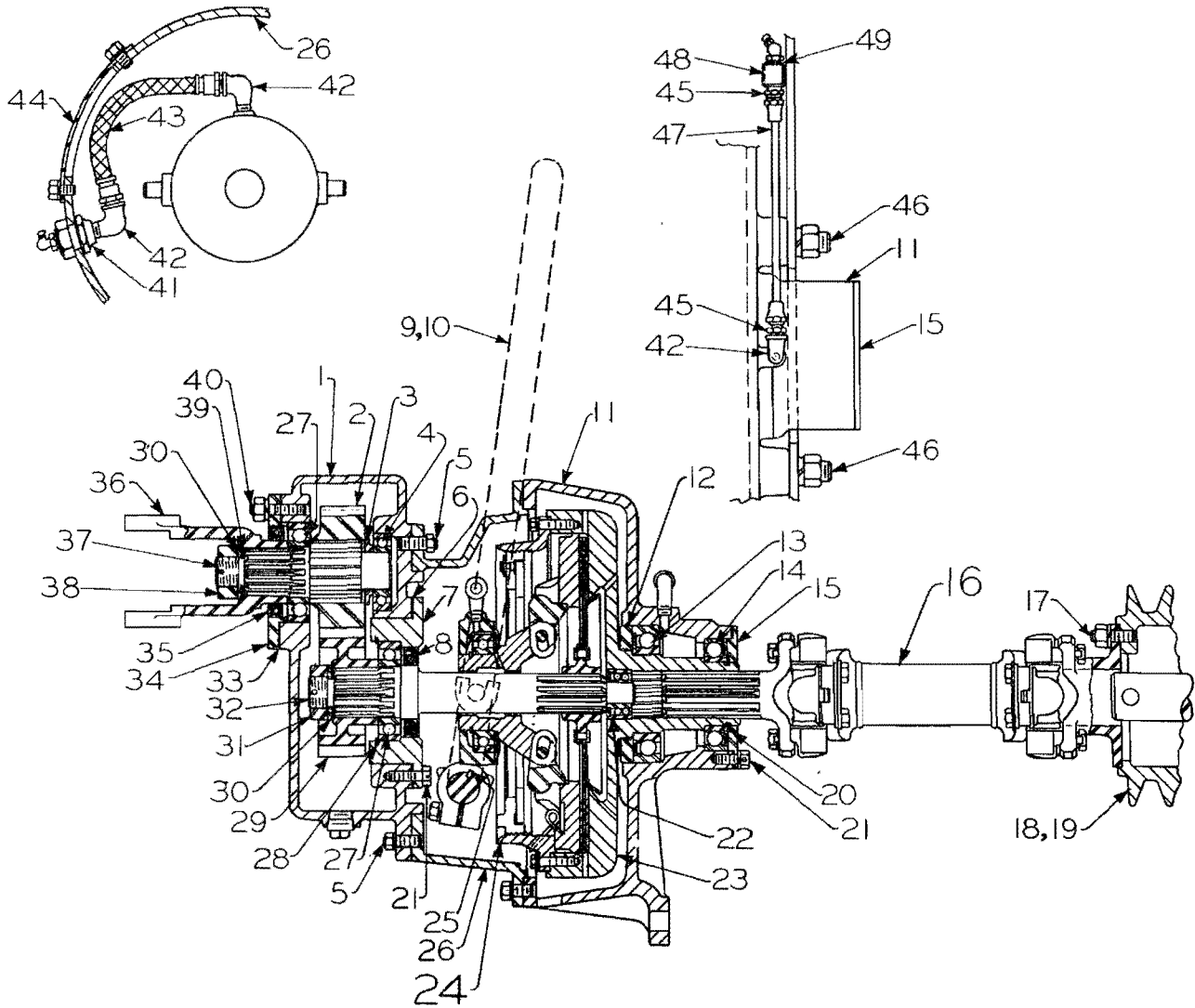

Figure 58. Conveyor Loader Tail Light and Horn Circuit

REF. NO.	PART NO.	QUANTITY	DESCRIPTION
1	PGF-9342	1	Horn (on loader)
2	PGF-9795	1	Wire-horn to horn button
3	PGF-9343	2	Horn button
4	PGF-5637	1	Wire-connector to horn button
5	PGF-5634	1	Wire-connector to horn buttons
6	PGF-10421	2	Connector
7	PGF-10380	1	Wire-connector to starter switch (live side)
8	PGF-10379	1	Wire-connector to horn
9	PGF-9342	1	Horn (on grader)
10		1	Starter switch
11		1	Wire-grader wiring harness
12	PGF-9966	1	Connector
13	PGF-10383	1	Wire-connector to connector
14	PGF-10421	1	Connector
15	PGF-10381	1	Wire-connector to tail lights (used with PGF-9341 tail light)
16	PGF-10749	1	Wire-connector to tail light connectors (used with PGF-10727 tail light)
17	PGF-10421	2	Connector (used with PGF-10727 tail light)
18	PGF-9341	2	Tail light (uses plug connector at lamp)
19	PGF-10727	2	Tail light (uses sleeve connector on wire)
	PGF-10385	1	Loom (not illustrated)
	PGF-5638	1	Flexible tube (not illustrated)

-M-



E/M PGU-1612

Figure 59. Conveyor Loader Power Take-off
for UD-14A Engine

<i>REF. NO.</i>	<i>PART NO.</i>	<i>QUANTITY</i>	<i>DESCRIPTION</i>
1	PG-1812	1	Gear housing
2	PGF-9658	1	Gear - 23 teeth
3	PGF-9661	1	Washer
4	311306	1	Ball bearing
5	BRF-2139	8	Stud
6	PGF-9663	1	Gasket
7	PG-1808	1	Bearing retainer
8	194066	1	Oil seal
9	PGF-5324	1	Clutch shift lever
10	PGF-7405	1	Clutch shift lever lock (not illustrated)
11	PG-1811	1	Clutch housing
12	PGF-5421	1	Grease retainer
13	311203	1	Ball bearing
14	311191	1	Ball bearing
15	PGF-5330	1	Plate
16	PGF-6785	1	Propeller shaft (see other pages)
17	BRF-1309	4	Stud-flange to pulley
18	PG-1074	1	Pulley (if UD-14A engine)
19	LRC-36-585	1	Pulley (if D-471 engine)
20	PGF-4394	1	Snap ring
21	PGF-1031	7	Cap screw
22	311598	1	Ball bearing
23	PG-1058	1	Clutch drum
24	PGF-5710	1	Clutch (see other pages)
25	111011	2	Yoke key
26	PG-1810	1	Housing
27	311314	2	Ball bearing
28	PGF-9662	1	Snap ring
29	PGF-9657	1	Gear - 23 teeth
30	KRF-369	2	Washer
31	856007	1	Nut
32	PGF-5320	1	Clutch shaft
33	PGF-9964	1	Gasket
34	PGF-9960	1	Retainer
35	PGF-8764	1	Oil seal
36	MUJCO-5642-J	1	Fitting yoke
37	PGF-9659	1	Shaft
38	PGF-3083	1	Nut
39	PGF-3221	3	Washer gasket
40	PGF-8433	3	Stud
41	PGF-5468	1	Hose adapter
42	563001	3	Elbow
43	PGF-4477	1	Grease hose
44	PGF-5336	1	Inspection plate
45	840003	2	Half union
46	PGF-3179	2	Stud
47	PGF-5627	1	Grease tube
48	PGF-5630	1	Clip
49	525001	1	Coupling

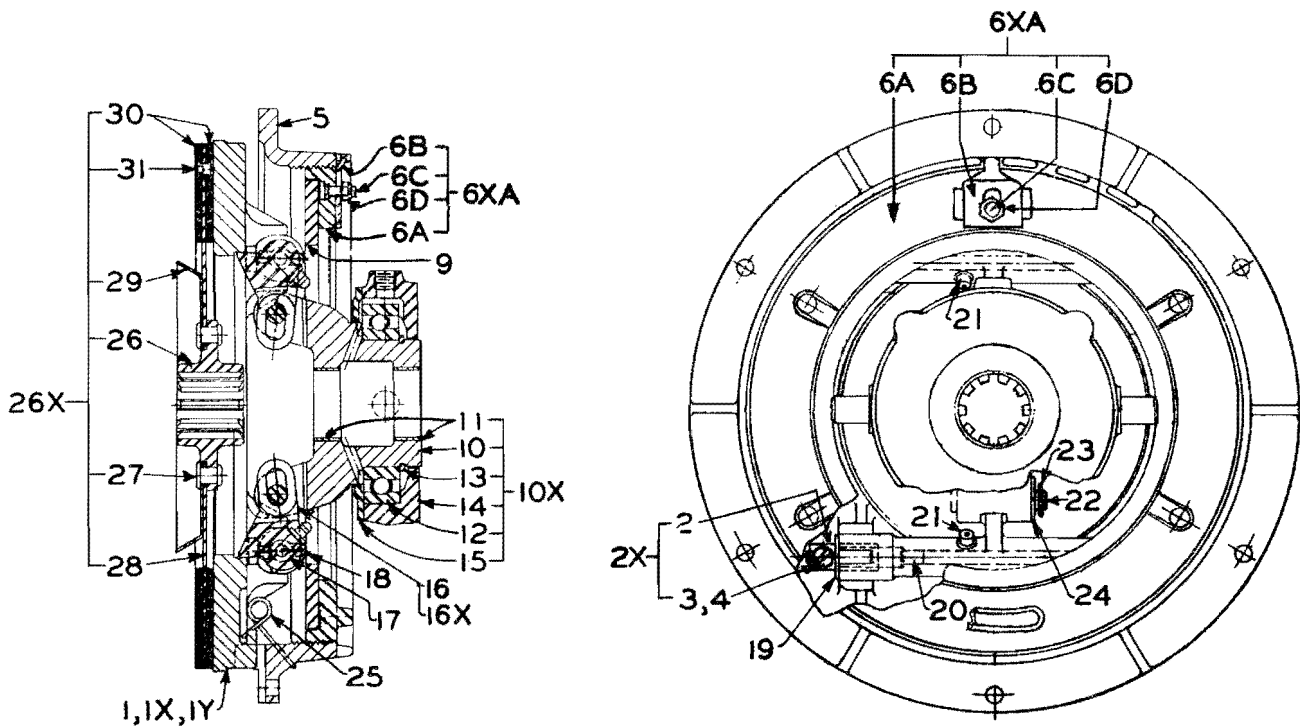
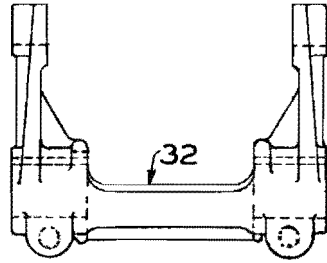

-0-

Figure 60. Conveyor Loader Power Take-off Clutch

REF. NO.	PART NO.	QUANTITY	DESCRIPTION
0	PGF-5710	1	Clutch group, complete
1X	RD-UCLA-43-3745	1	Cover group (includes Ref. Nos. 1 to 25 incl.)
1Y	RD-UCL-3744	1	Pressure plate group (includes Ref. Nos. 1 and 2X)
1		1	* Pressure plate
2X	RD-UCL-3478-S4	1	Cam block group (includes Ref. Nos. 2,3 and 4)
2	RD-CL-3478	4	Cam block
3	RD-CL-3921	4	Fillister head screw - 1/4"-20NC x 1/2"
4	RD-CL-4799	4	Screw lock
5	RD-CL-3745	1	Back plate
6XA	RD-UCL-4824-1	1	Adjusting ring group (includes Ref. Nos. 6A, 6B, 6C and 6D)
6A		1	% Adjusting ring
6B	RD-CL-5248	1	Adjusting lock
6C	RD-CL-5215	1	Adjusting lock screw
6D	RD-CL-1608	1	Adjusting lock nut
9	RD-CL-3747-1	1	Adjusting ring plate
10X	RD-UCL-1-4601-A	1	Sleeve and bearing group (includes Ref. Nos. 10 to 15 inclusive)
10	RD-UCL-4601	1	Sleeve with bushing (includes Ref. No. 11)
11	RD-CL-3089	2	Bushing
12	RD-CL-3353	1	Ball bearing
13	RD-CL-3302	1	Snap ring
14	RD-CL-3400-1	1	Bearing carrier
15	RD-CL-3401	1	Bearing carrier plate
16X	RD-UCL-4600-S2A	1	Cam shaft group (includes Ref. Nos. 2X and 16 to 21 inclusive)
16		2	& Cam shaft
17		4	& Roller-large
18		8	& Roller-small
19		4	& Roller retainer plate
20		4	& Felt plug
21		2	& Grease fitting (#5029 Lincoln)
22	RD-CL-4586	2	Lever pin (sleeve to cam)
23	RD-CL-4597	2	Cotter pin - 1/8" x 5/8"
24	RD-CL-4347	2	Washer - 5/16"
25	RD-CL-2326	4	Return spring
26X	RD-UCL-24-862	1	Drive member group (includes Ref. Nos. 26 to 31 inclusive)
26		1	£ Center
27		6	£ Flat head rivet
28		1	£ Clutch plate
29		1	£ Oil slinger
30	RD-CL-4136	2	Facing
31	RD-CL-1011	20	Tubular rivet
32	RD-UPT-128	1	Yoke group (includes screws and lock washers)

Note: * Indicates parts not sold separately. Order Ref. No. 1Y.
 % Indicates parts not sold separately. Order Ref. No. 6XA.
 & Indicates parts not sold separately. Order Ref. No. 16X.
 £ Indicates parts not sold separately. Order Ref. No. 26X.

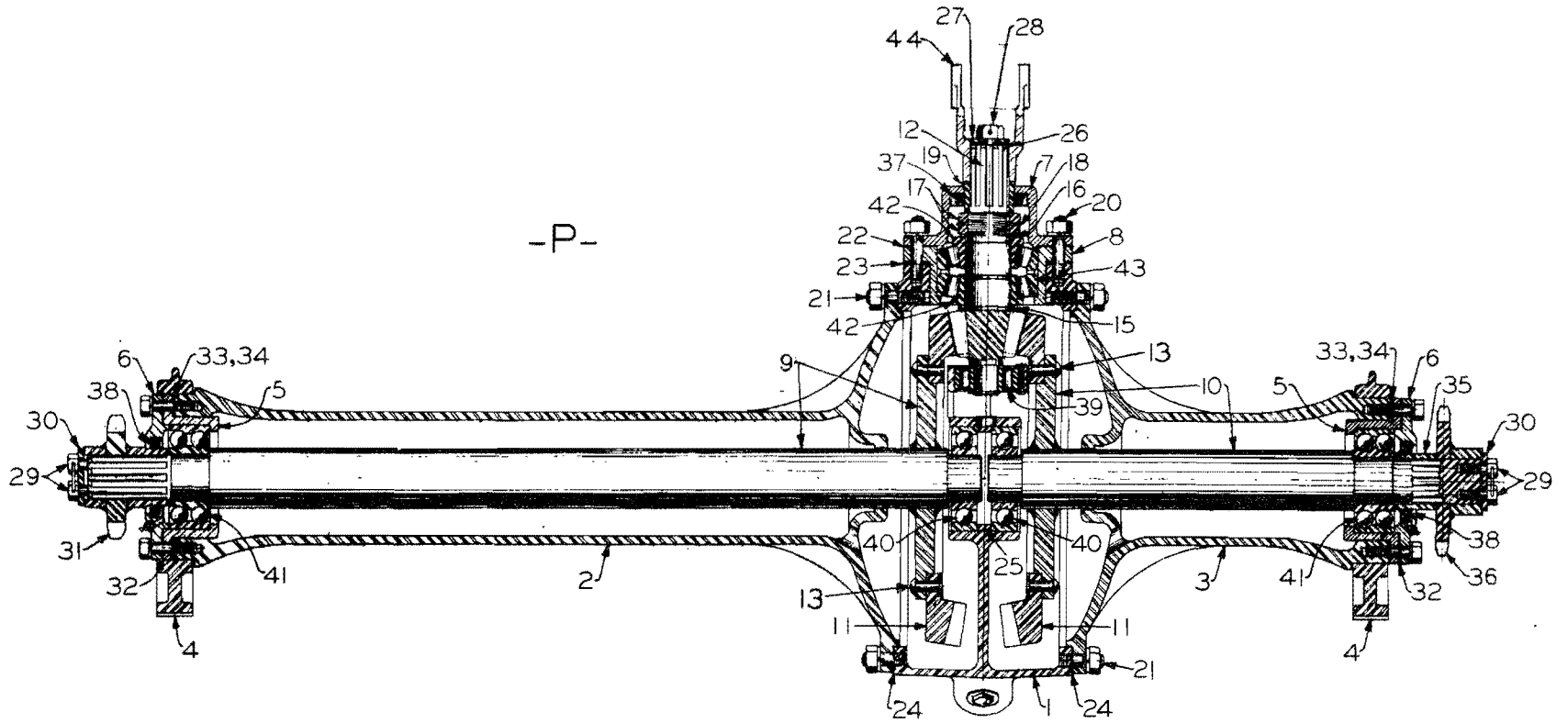

Figure 61. Conveyor Loader Bevel Gear Drive

REF. NO.	PART NO.	QUANTITY	DESCRIPTION
1	PG-1045	1	Gear case
2	PG-1048	1	Housing
3	PG-1049	1	Housing
4	PG-1809	2	Housing support
5	PG-1053	2	Bearing cage
6	PG-1054	2	Cap
7	PG-1017	1	Seal retainer
8	PG-1050	1	Bearing carrier
9	PGF-5287	1	Shaft with flange
10	PGF-5288	1	Shaft with flange
11	PGF-8330	2	* Bevel gear
12	PGF-8330	1	* Bevel pinion
13	572359	24	Rivet-round head
15	5YF-205	1	Spacer
16	PGF-5344	1	Washer
17	PGF-5343	2	Nut
18	PGF-5345	1	Washer
19	PGF-5339	1	Spacer
20	PGF-2840	4	Stud
21	PGF-4383	16	Stud
22	PGF-5337	1	Gasket
23	195034	3	Shim - .005" thick
23	195035	3	Shim - .007" thick
23	195036	As req'd.	Shim - .020" thick
24	PGF-5304	2	Gasket
25	PGF-5338	1	Spacer
26	BTF-925	1	Gasket
27	BTF-926	1	Washer
28	PGF-5340	1	Cap screw
29	BTF-743	4	Cap screw
30	PGF-4916	2	Retainer
31	PGF-5289	1	Sprocket - 10 teeth
32	PGF-5274	2	Gasket
33	PGF-5276	10	Shim - .005" thick
34	PGF-5277	10	Shim - .010" thick
35	PGF-5346	1	Spacer
36	PGF-5410	1	Sprocket - 16 teeth
37	194010	1	Oil seal
38	194134	2	Oil seal
39	318180	1	Rollway bearing
40	311367	2	Ball bearing
41	311451	2	Ball bearing
42	312836	2	Bearing cone and rollers
43	313382	1	Bearing cup
44	MUJCO-5641-J	1	Fitting yoke

Note: * Bevel gear and bevel pinion sold in matched sets only.

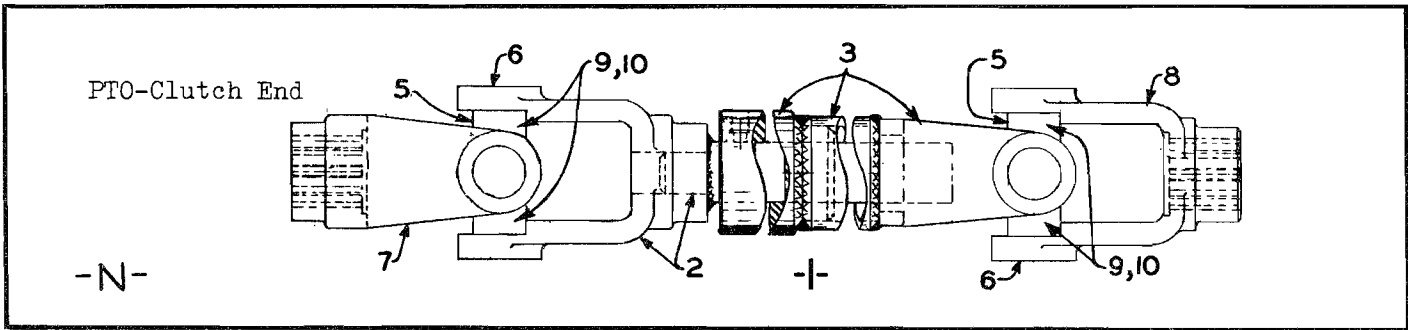

Figure 62. Conveyor Loader Propeller Shaft
(Power Take-off to Bevel Gear Drive)

REF. NO.	PART NO.	QUANTITY	DESCRIPTION
1	PGF-9823	1	Propeller shaft, complete
2	MUJCO-105-4614	1	Yoke with square shaft group
3	MUJCO-42-4614	1	Yoke with tube group
	MUJCO-114-3008	2	Spider and bearing group (includes Ref. Nos. 5, 6, 9 and 10)
5	MUJCO-112-3000	2	Spider group (includes dust shields)
6	MUJCO-113-3012	8	Bearing group
7	MUJCO-5642-J	1	Fitting yoke
8	MUJCO-5641-J	1	Fitting yoke
9	MUJCO-3565-J	8	Cork trunnion washer
10	MUJCO-5320-J	8	Snap ring

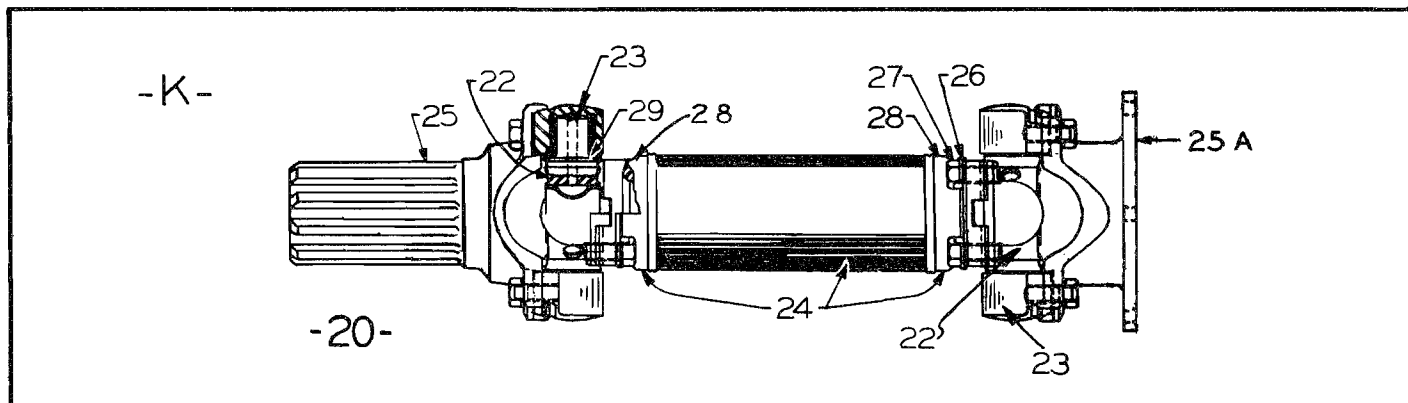

Figure 63. Conveyor Loader Propeller Shaft
(Power Take-off to Engine Pulley)
for UD-14A Engine

REF. NO.	PART NO.	QUANTITY	DESCRIPTION
20	PGF-6785	1	Propeller shaft, complete
	MUJCO-114-3000	2	Spider and bearing group (includes Ref. Nos. 22, 23, 26, 27 and 29)
22	MUJCO-112-3000	2	Spider group
23	MUJCO-113-3006	8	Bearing group
24	MUJCO-42-3455	1	Propeller tube group (includes Ref. No. 28)
25	MUJCO-5550-J	1	Stub yoke
25A	MUJCO-5551-J	1	Flanged fitting
26	MUJCO-3549-J	8	Cap screw lock plate
27	MUJCO-3786-J	16	Cap screw
28	MUJCO-3922-J	2	Weld yoke
29	MUJCO-3565-J	8	Cork trunnion washer

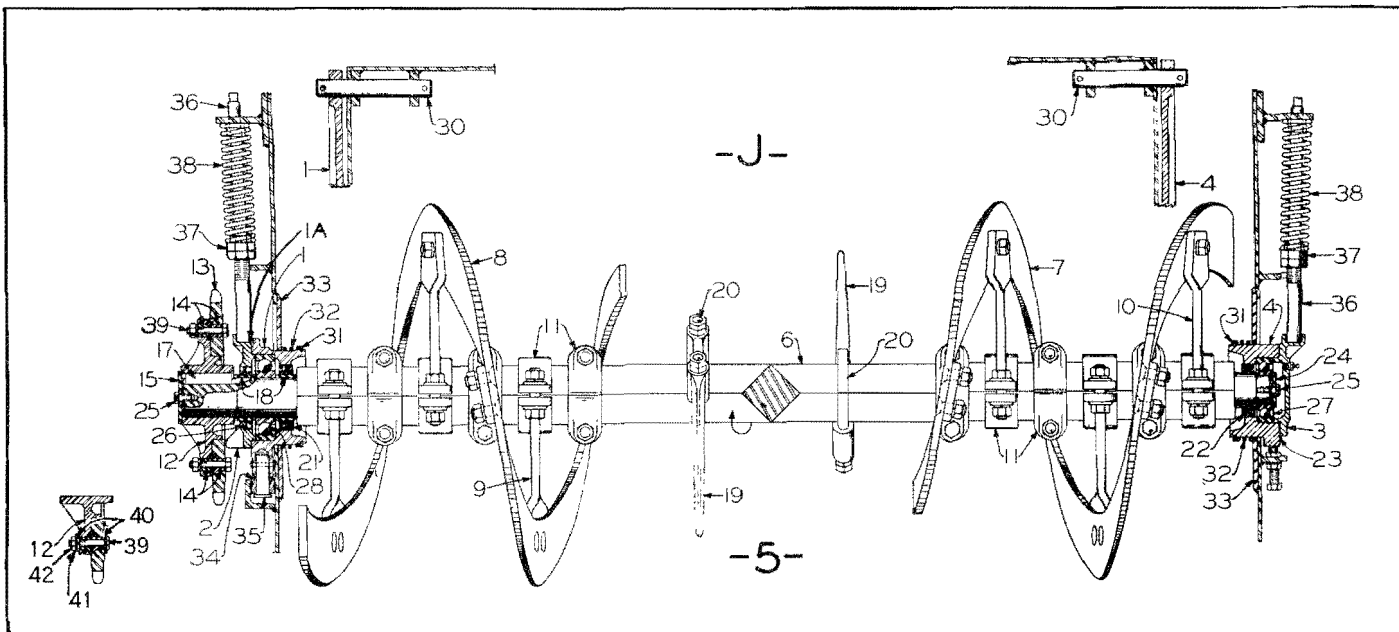

Figure 64. Conveyor Loader Feeder Shaft

REF. NO.	PART NO.	QUANTITY	DESCRIPTION
1	PG-1309	1	Pivot arm
1A	PGF-7355	1	Gasket
2	PG-1365	1	Cap
3	PG-1364	1	Cap
4	PG-1310	1	Pivot arm
5	PGU-1577	1	Feeder shaft group (includes Ref. Nos. 6, 7, 8, 9, 10, 11, 19 and 20)
6	PGF-4909	1	Shaft
7	PGF-6779	1	Spiral
8	PGF-6780	1	Spiral
9	PG-1060	6	Arm
10	PG-1061	6	Arm
11	PG-1062	12	Cap
12	PG-1068-X	1	Sprocket hub with bushing (includes 2 of Ref. No. 14)
13	PGF-5301-X	1	Sprocket (30 th.) with bushing (inc. 2 of Ref. No. 14)
14	PGF-5380	4	Bushing
15	PGF-4918	1	Retainer
17	PGF-5558	1	Key
18	PGF-4917	2	Spacer
19	PGF-5353	2	Cutter blade
20	PGF-5354	2	"U" bolt
21	PGF-4921	1	Oil seal
22	PGF-4922	1	Oil seal
23	PGF-4920	1	Gasket
24	PGF-4916	1	Retainer
25	BTF-743	4	Cap screw
26	194092	1	Oil seal
27	311367	1	Ball bearing
28	311376	1	Ball bearing
30	PGF-6719	2	Pivot arm pin
31	PGF-6721	2	Lock ring
32	PGF-6720	2	Spring
33	PGF-6717	2	Guard
34	PGF-6727	1	Roller
35	PGF-6726	1	Roller pin
36	PGF-7193	2	Spring bolt
37	PGF-7194	2	Spring bolt nut
38	PGF-7216	2	Spring
39	742329	2	Shear bolt
40	762004	4	Washer
41	778011	2	Lock washer
42	722003	2	Nut

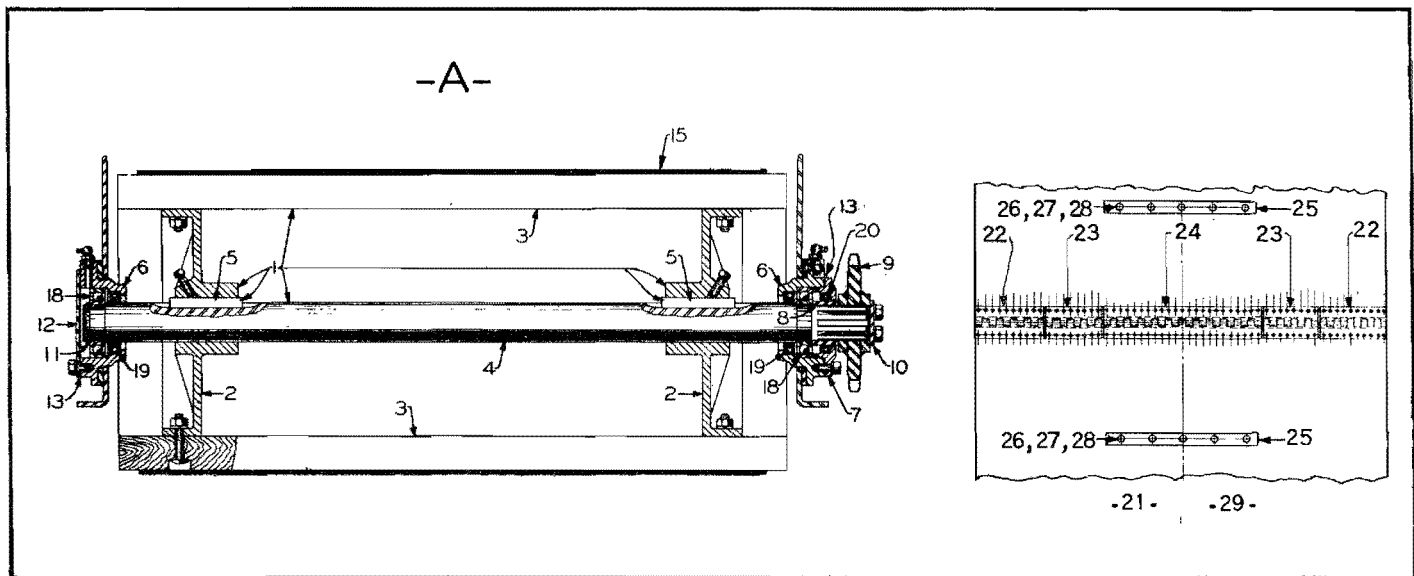
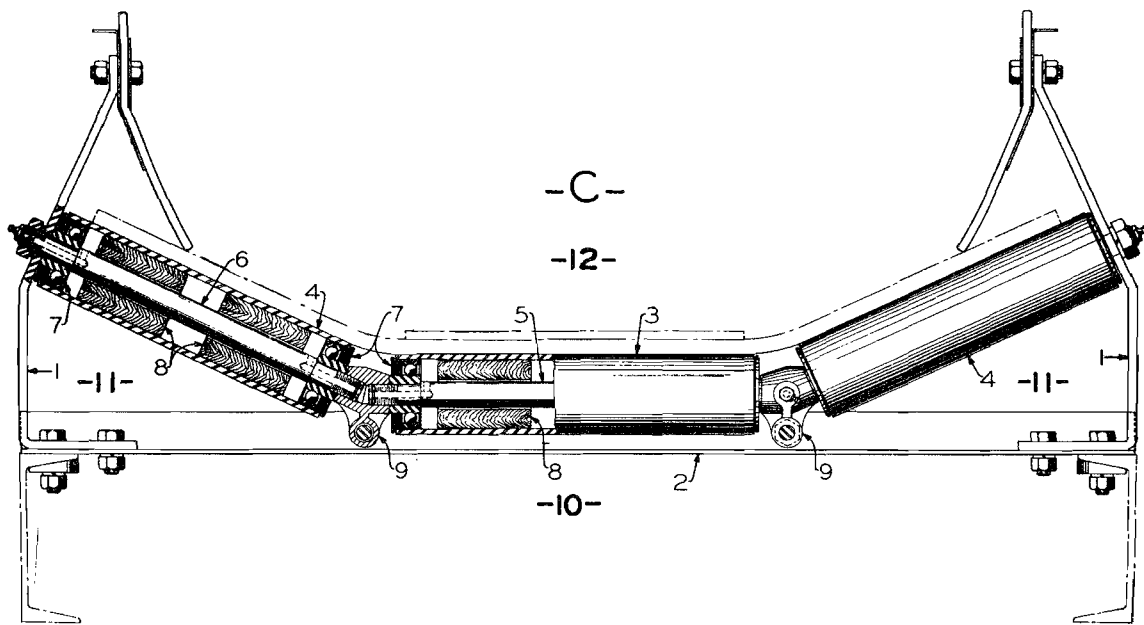

Figure 65. Conveyor Loader Head Drum and Belt

REF. NO.	PART NO.	QUANTITY	DESCRIPTION
1	PGU-1462	1	Head drum and shaft group (includes Ref. Nos. 2,3,4,5 and 15)
2	O1-21351	2	Head
3	PGF-5328	15	Cleat
4	PGF-4960	1	Shaft
5	PGF-5534	2	Key
6	PG-1381	2	Bearing housing
7	WK-33	1	Seal retainer
8	PGF-4943	1	Spacer
9	PGF-5408	1	Sprocket - 19 teeth
10	PGF-4916	1	Retainer
11	PGF-3609	1	Snap ring
12	WKF-804	1	Cover
13	PGF-3210	2	Gasket
15	PGF-10530	1	Lagging
18	314058	2	Ball bearing
19	194074	2	Oil seal
20	194026	1	Oil seal
21	PGUS-9212	1	Belt with splices (includes Ref. Nos. 22, 23 and 24)
22	PGF-6810	2	Outer belt splice
23	PGF-6811	2	Inner belt splice
24	PGF-9630	1	Center belt splice
25	PGF-5641	32	Cleat
26	CSF-1223	160	Cleat bolt
27	NES-2048	160	Cleat bolt washer
28	PGF-10086	160	Cleat bolt nut
29	PGU-1820	1	Belt with cleat group (includes Ref. Nos. 22 to 28 inclusive)



B/M PGU-1458

Figure 66. Conveyor Loader Upper Carrying Roller

REF. NO.	PART NO.	QUANTITY	DESCRIPTION
1	PGF-5314	2	Support
2	PGF-5315	2	Angle
3	PGF-5316	1	Roller
4	PGF-5317	2	Roller
5	PGF-5318	1	Shaft
6	PGF-5319	2	Shaft
7	WKF-688	6	Bearing
8	WKF-696	6	Retainer
9	WK-10	2	Bracket
10	PGU-1456	1	Center roller group (includes Ref. Nos. 3, 5, 7 and 8)
11	PGU-1457	2	Side roller group (includes Ref. Nos. 4, 6, 7 and 8)
12	PGU-1458	1	Upper carrying roller group (includes Ref. Nos. 1, 2, 9, 10 and 11)

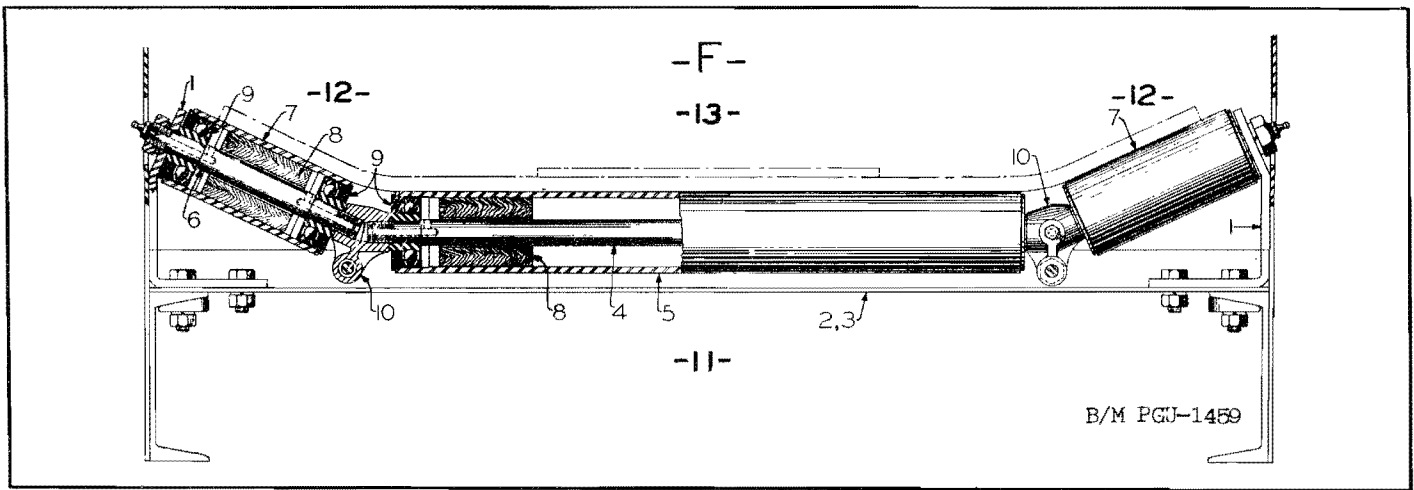

Figure 67. Conveyor Loader Intermediate Carrying Roller

REF. NO.	PART NO.	QUANTITY	DESCRIPTION
1	PGF-5350	2	Support
2	PGF-5478	1	Angle-lower
3	PGF-5479	1	Angle-upper (not shown)
4	PGF-4937	1	Shaft
5	PGF-4936	1	Roller
6	WKF-692	2	Shaft
7	WKF-695	2	Roller
8	WKF-696	4	Retainer
9	WKF-688	6	Bearing
10	WK-10	2	Bracket
11	PGU-1439	1	Center roller group (includes Ref. Nos. 4, 5,8 and 9)
12	PGU-1455	2	Side roller group (includes Ref. Nos. 6,7, 8 and 9)
13	PGU-1459	1	Intermediate carrying roller group (includes Ref. Nos. 1,2,3,10,11 and 12)

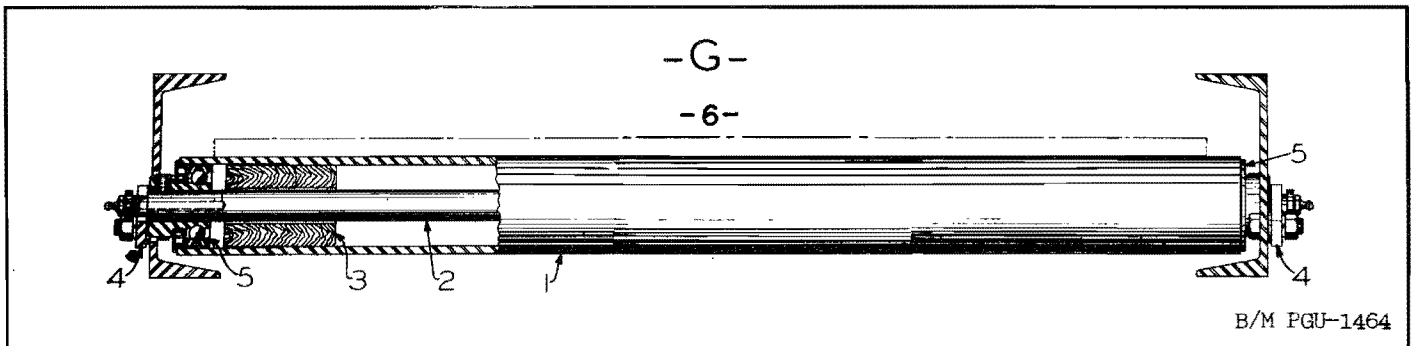

Figure 68. Conveyor Loader Lower Carrying Roller

REF. NO.	PART NO.	QUANTITY	DESCRIPTION
1	03-46796	1	Roller
2	03-46798	1	Shaft
3	WKF-696	2	Retainer
4	WKF-905	2	Clip
5	311599	2	Bearing
6	PGU-1464	1	Lower carrying roller group (includes Ref. Nos. 1,2,3 and 5)

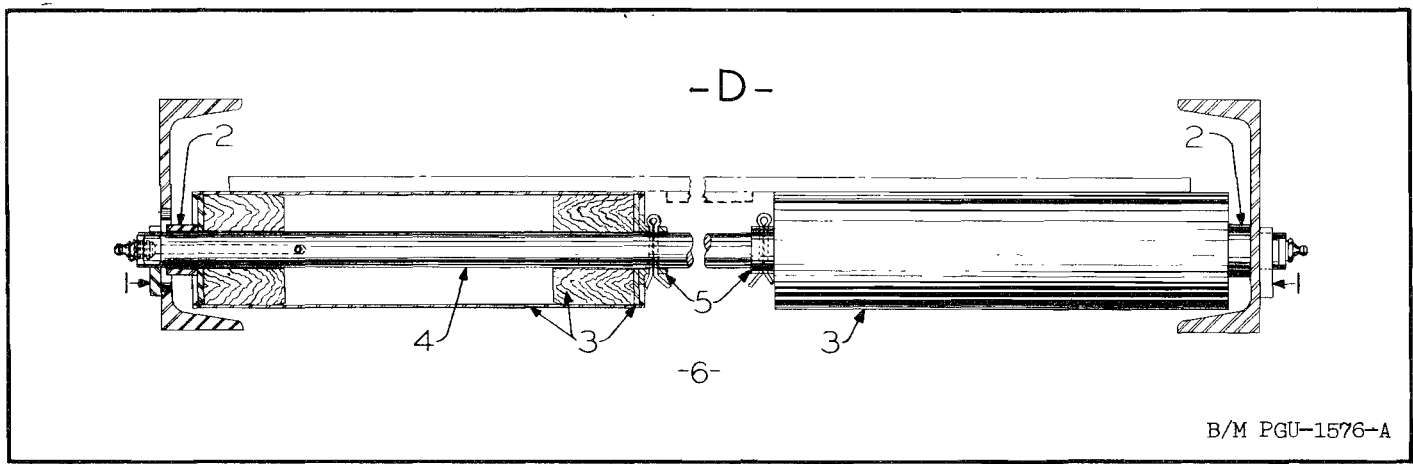

Figure 69. Conveyor Loader Return Roller

REF. NO.	PART NO.	QUANTITY	DESCRIPTION
1	WKF-905	2	Clip
2	PGF-8165	2	Spacer
3	PGF-8164	2	Roller group
4	PGF-6846	1	Shaft
5	PGF-8163	2	Collar
6	PGU-1576-A	1	Return roller group (includes Ref. Nos. 2,3,4 and 5)

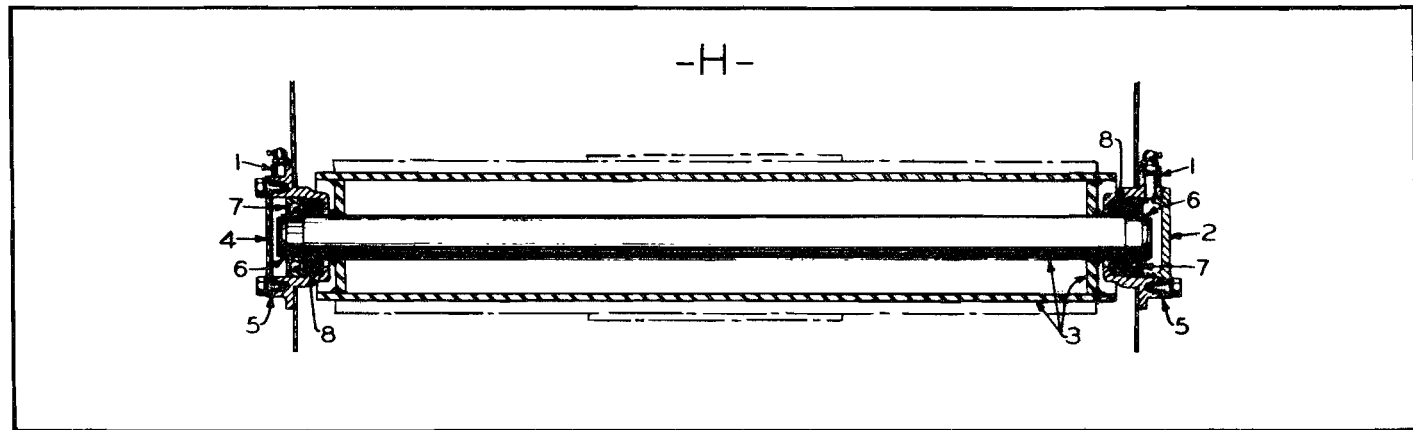

Figure 70. Conveyor Loader Tail Pulley

REF. NO.	PART NO.	QUANTITY	DESCRIPTION
1	WK-30	2	Bearing housing
2	PG-1028	1	Cap
3	PGF-4952	1	Tail pulley
4	WKF-818	1	Cover
5	CAF-873	2	Gasket
6	ASF-3267	2	Snap ring
7	311314	2	Ball bearing
8	194070	2	Oil seal

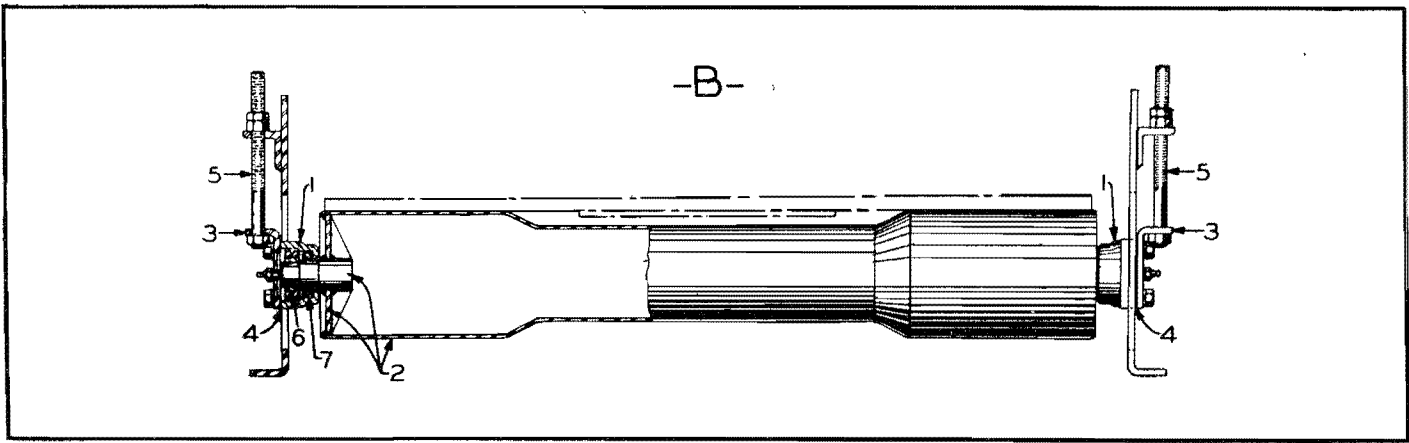

Figure 71. Conveyor Loader Snub Roller

REF. NO.	PART NO.	QUANTITY	DESCRIPTION
1	PG-1055	2	Bearing cage
2	PGF-5286	1	Roller
3	PGF-5284	2	Cover
4	PGF-5285	2	Cover gasket
5	PGF-5297	2	Take-up bolt
6	314050	2	Ball bearing
7	194020	2	Oil seal

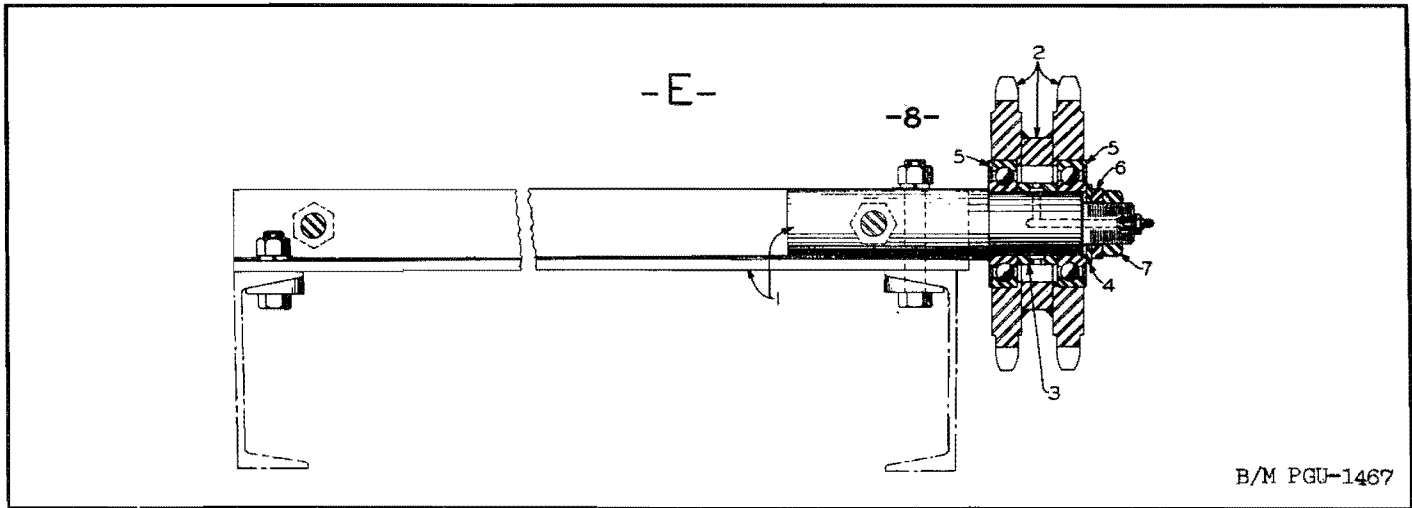

Figure 72. Conveyor Loader Countershaft

REF. NO.	PART NO.	QUANTITY	DESCRIPTION
1	PGF-4946	1	Shaft with angle
2	PGF-5409	1	Double sprocket - 21 teeth
3	PGF-4950	1	Spacer
4	PGF-4620	1	Washer
5	311169	2	Ball bearing
6	778021	1	Lock washer
7	737010	1	Jam nut
8	PGU-1467	1	Countershaft group (includes Ref. Nos. 1 to 7 inclusive)

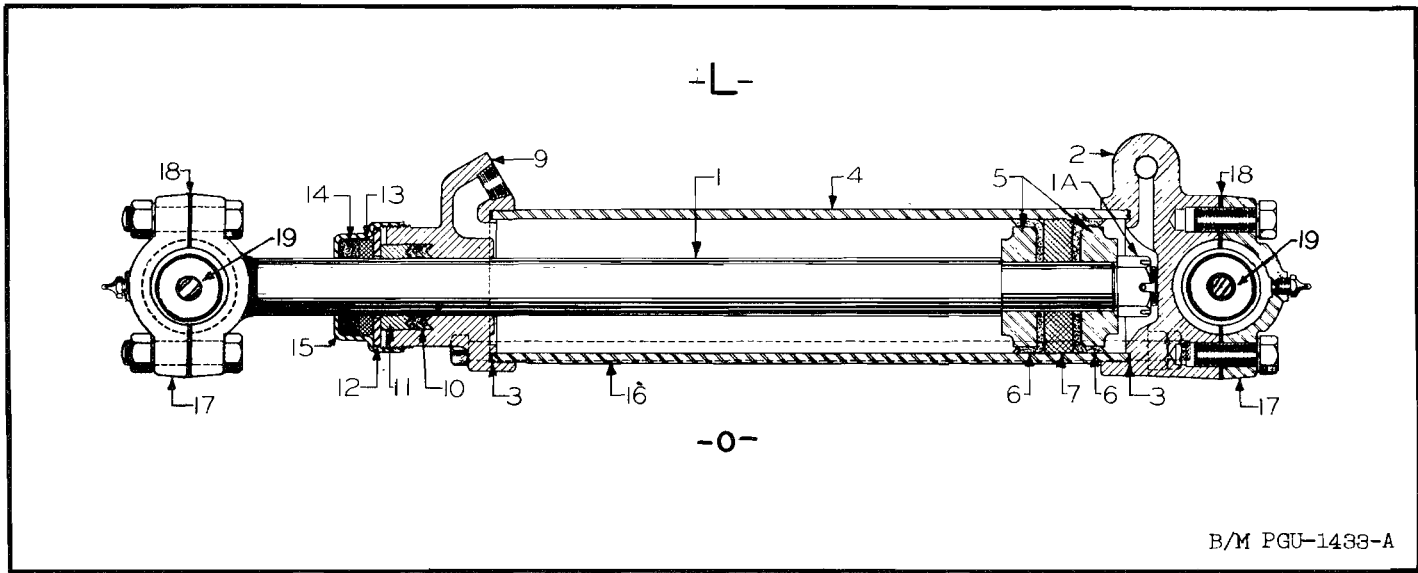

Figure 73. Conveyor Loader Lift Ram

REF. NO.	PART NO.	QUANTITY	DESCRIPTION
0	PGU-1433-A	2	Conveyor loader lift ram group (includes Ref. Nos. 1 to 19 inclusive)
1	PGF-5342	1	Piston rod
1A	737010	1	Slotted nut
2	PG-1059	1	Base
3	RGF-6419	2	Gasket
4	PGF-4964	1	Cylinder
5	RGF-4776	2	Spreader
6	PGF-689	2	Cup
7	BT-82	1	Piston
9	PG-1346	1	Head
10	RGF-4382	3	Chevron packing ring
11	PG-1348	1	Press ring
12	PGF-7025	1	Retainer
13	PGF-6997	1	Felt
14	PGF-1699	1	Wiper
15	PGF-7019	1	Cap
16	PGF-5418	4	Tie rod
17	PGF-1652	2	Ball cap
18	MGF-1992	40	Ball cap shim
19	PGF-609	2	Ball

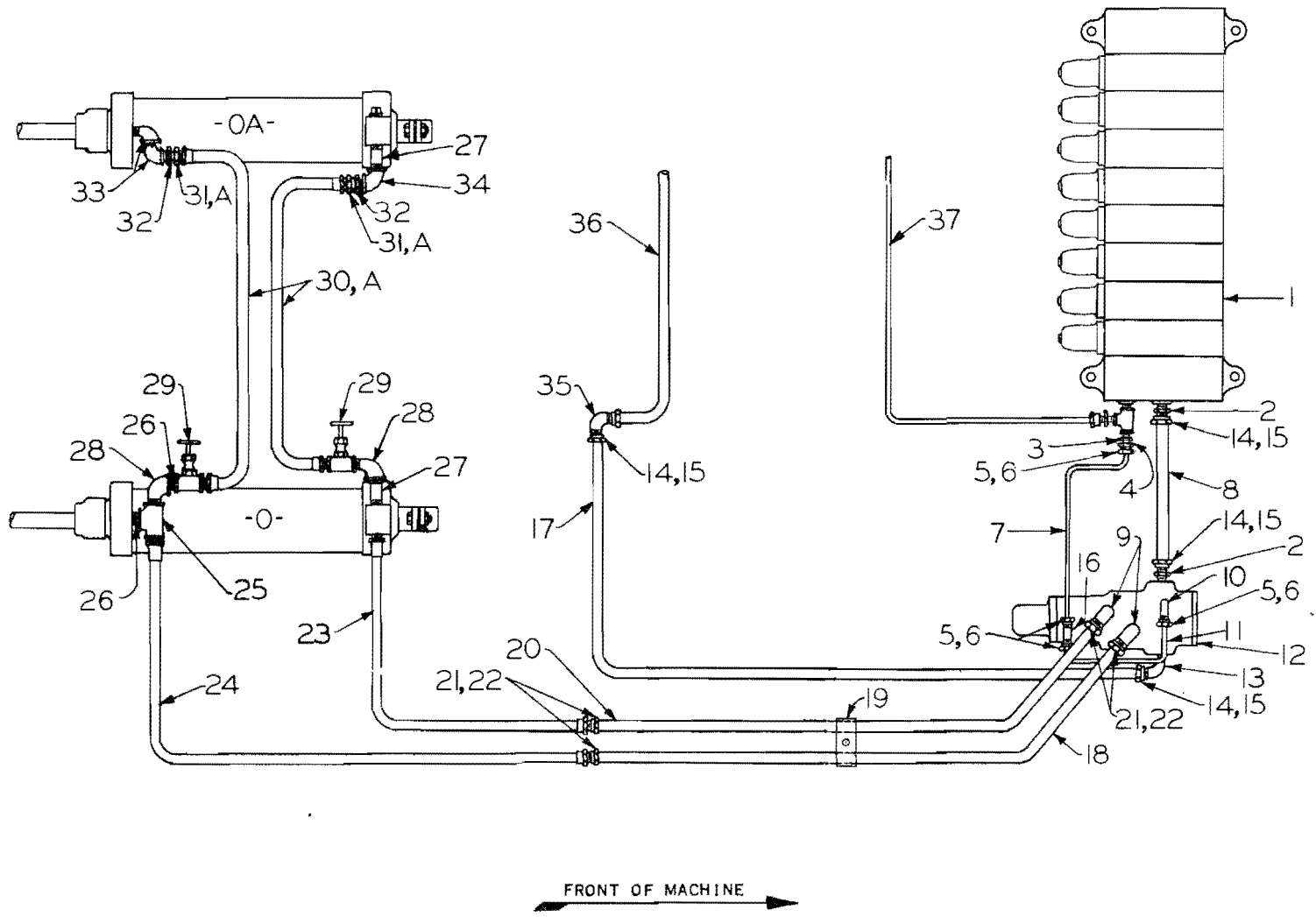

Figure 74. Conveyor Loader Hydraulic System (Piping Diagram)

REF. NO.	PART NO.	QUANTITY	DESCRIPTION
0		1	Lift ram group-right hand
0A		1	Lift ram group-left hand
1		1	Valve bank group
2	PGF-10143-8	2	Male connector
3	526001	1	Reducer bushing
4	PGF-10143-3	1	Male connector
5	PGF-9496-3	4	Coupling sleeve (for 1/4" OD tube)
6	PGF-9497-3	4	Coupling nut (for 1/4" OD tube)
7	PGF-9806	1	Drain line - 1/4" OD x 14-1/4" (approx.) (includes 2 of Ref. Nos. 5 and 6)
8	PGF-9803	1	Return line - 3/4" OD x 9-3/16" (approx.) (includes 2 of Ref. Nos. 14 and 15)
9	PGF-10144-7	2	Elbow
10	PGF-10144-3	1	Elbow
11	PGF-9808	1	Drain line - 1/4" OD x 8-3/4" (approx.) (includes 2 of Ref. Nos. 5 and 6)
12		1	Control valve group
13	PGF-10144-8	1	Elbow
14	PGF-9496-8	4	Coupling sleeve (for 3/4" OD tube)
15	PGF-9497-8	4	Coupling nut (for 3/4" OD tube)
16	PGF-10147-3	1	Tee
17	PGF-9802	1	Return line - 3/4" OD x 19-3/16" (approx.) (includes 2 of Ref. Nos. 14 and 15)
18	PGF-9791	1	Tube - 5/8" OD x 115-1/4" (approx.) (includes 2 of Ref. Nos. 21 and 22)
19	PGF-7524	2	Tube clamp
20	PGF-9778	1	Tube - 5/8" OD x 116-5/8" (approx.) (includes 2 of Ref. Nos. 21 and 22)
21	PGF-9496-7	4	Coupling sleeve (for 5/8" OD tube)
22	PGF-9497-7	4	Coupling nut (for 5/8" OD tube)
23	PGF-9788	1	* Hydraulic hose - 24-1/4" overall length
24	PGF-9759	1	* Hydraulic hose - 36-1/4" overall length
25	PGF-9539-4	1	Tee
26	532138	2	Pipe nipple
27	BRF-1104	2	Pipe
28	PGF-9537-4	2	Elbow
29	PGF-9930	2	Needle valve
30	RGF-4940	2	Hydraulic hose - 57" exposed rubber (has 1/2" union collar thread one end)
30A	PGF-10771	2	* Hydraulic hose - 60-7/8" overall length (has 1/2" pipe threads both ends)
31	PGF-2360	2	Union ring (used with RGF-4940 hydraulic hose)
31A	HCF-362	2	Adapter union (used with PGF-10771 hydraulic hose)
32	PGF-2361	2	Union tail piece (used with RGF-4940 hydraulic hose)
33	558004	2	Elbow
34	PGF-9538-4	1	Elbow
35	PGF-10161-8	1	Elbow
36		1	Regular return line (to tank)
37		1	Return drain line (to tank)

Note: * Hydraulic hose dimensions given are overall lengths including end fittings.

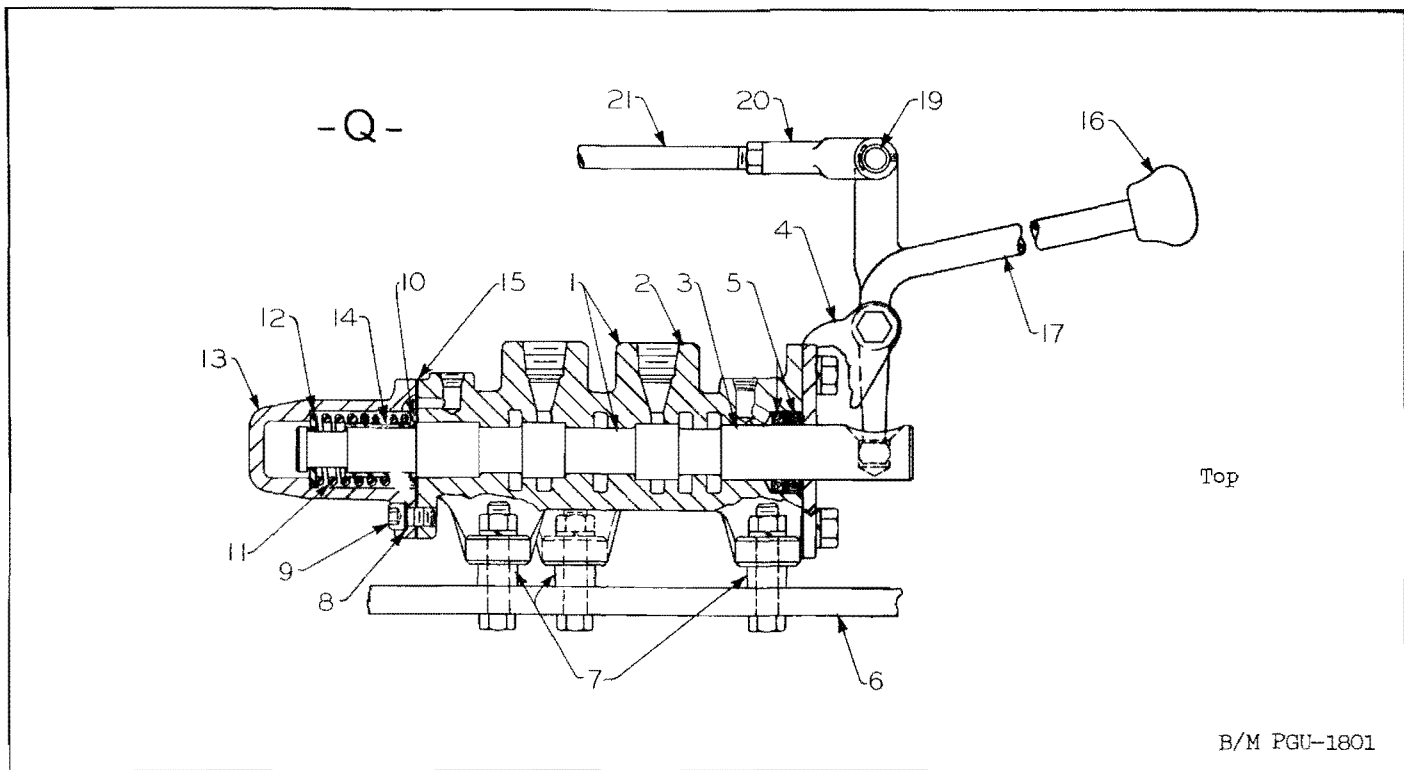

Figure 75. Conveyor Loader Hydraulic Control Valve

REF. NO.	PART NO.	QUANTITY	DESCRIPTION
1	PGU-1800	1	Body with valve (includes Ref. Nos. 2 and 3)
2		1	* Valve body
3		1	* Valve plug (movable)
4	PG-1832	1	Valve lever bracket
5	PGF-8946	2	Oil seal
6		1	Valve support plate
7	AJF-3215	3	Valve body spacer
8	HCF-373	4	Washer
9	819133	4	Cap screw-hollow head
10	PGF-8783	1	Washer
11	PGF-8775	1	Valve spring
12	PGF-8780	1	Washer
13	AS-1010	1	Valve spring cap
14	PGF-8781	1	Sleeve
15	ASF-5105	1	Valve spring cap gasket
16	PG-1400	1	Valve lever ball
17	PGF-9765	1	Valve lever
19	783004	1	Rod end pin
20	782004	1	Rod end fork
21	PGF-9822	1	Control rod

Note: * Indicates parts not sold separately. Order Ref. No. 1 - PGU-1800, body with valve, from your nearest Austin-Western distributor.

FACTORY ATTACHED CONNECTIONS

This end has standard 1/2" pipe thread

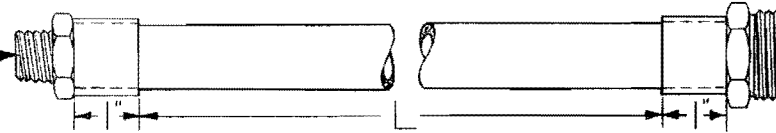

This end has 1/2" union collar thread

Note: In ordering hose always be governed by the length of the exposed rubber. See (L)

Length (L)	Part No.	Length (L)	Part No.	Length (L)	Part No.
41-1/2"	RGF-5065	48"	PGF-1458	57"	RGF-4940

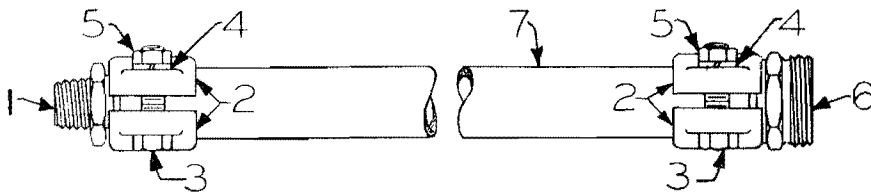

Field Service 1/2" I.D. Hydraulic Hose and Connections

REF. NO.	PART NO.	QUANTITY PER HOSE UNIT	DESCRIPTION
1	PGF-2075	1	Hose and pipe coupling - 1/2" pipe thread
2	PGF-2077	4	Hose clamp
3	742166	4	Cap screw
4	778010	4	Lock washer
5	722002	4	Hex nut
6	PGF-2076	1	Hose and union coupling - 1/2" union collar thread
7			Hydraulic hose - specify length wanted

Make up your own hose by keeping a supply of hydraulic hose (in random length) and hose clamps on hand. To determine length of hose required measure the length of exposed rubber of the hose you wish to duplicate and add 2". Cut hose with a high speed hacksaw blade having 18 or 24 teeth per inch.

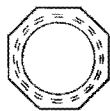

27/32"
Approx.

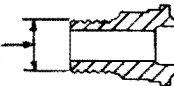

PGF-2360 union ring or collar
used with PGF-2361

PGF-2361 union tail piece
(1/2" IPT-male)

Figure 76. Hydraulic Hose Chart for Conveyor Loader and Rear Roller

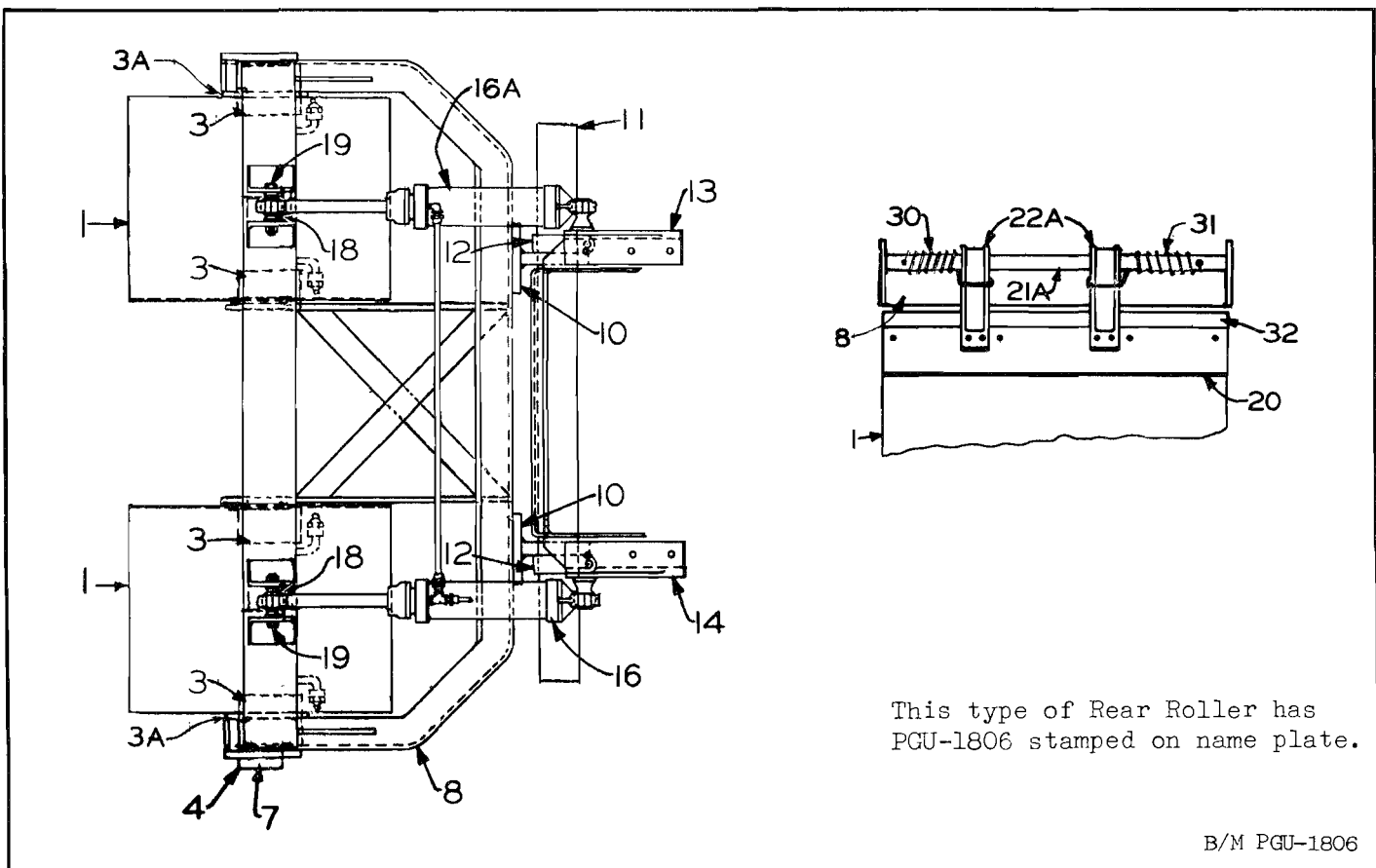

Figure 77. Rear Roller

REF. NO.	PART NO.	QUANTITY	DESCRIPTION
1	PGU-6806	2	Roller with bushings (includes 2 of Ref. No. 3)
3	PG-991	4	Roller bushing
3A	PGF-4677	2	Washer
4	PGF-6807	1	Axle
7	RRF-455	1	Pin
8	PGF-9687	1	Frame
10	PGF-4770	2	Pivot bracket
11		1	Rear bumper
12	PGF-4485	2	Lock collar
13	PGF-9688	1	Ball bracket-left hand
14	PGF-9684	1	Ball bracket-right hand
16		1	Ram group-right hand
16A		1	Ram group-left hand
18		2	Ram connection ball
19	PGF-1724	2	Bolt
20	PGF-6809	4	Blade
21A	PGF-6808	4	Shaft
22A	BR-50	8	Hanger
30	TRF-747	4	Spring-left hand wound
31	TRF-746	4	Spring-right hand wound
32	PGF-6820	2	Cocoa mat (special order)

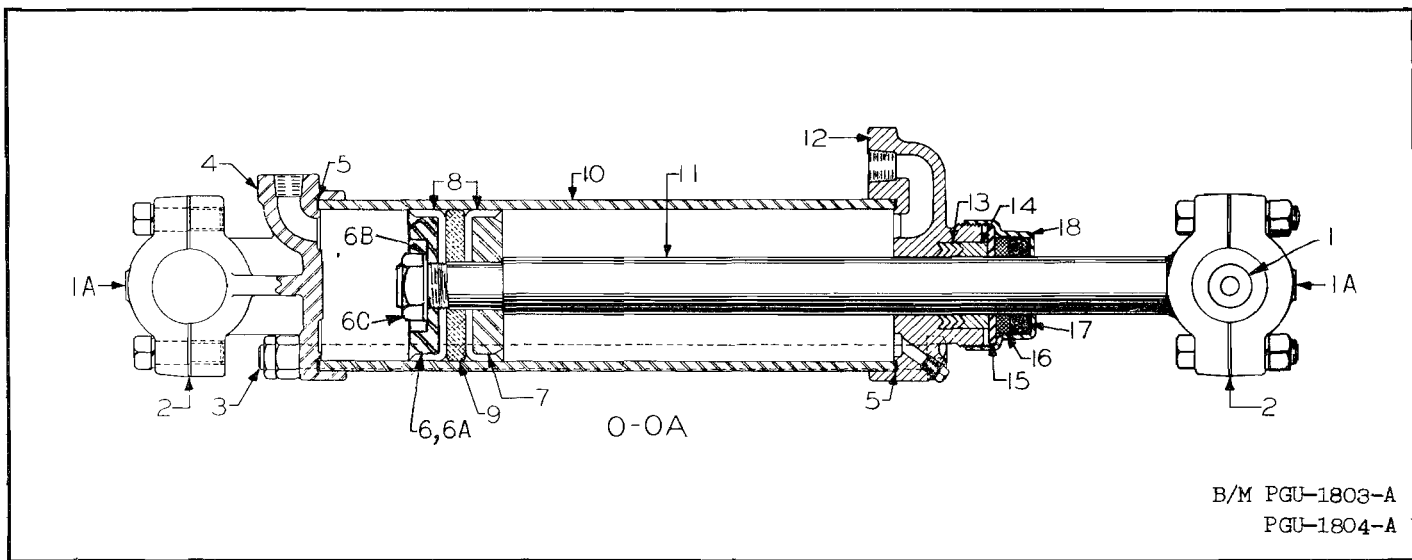

Figure 78. Rear Roller Ram

REF. NO.	PART NO.	QUANTITY	DESCRIPTION.
0	PGU-1803-A	1	Roller ram group-right hand (includes Ref. Nos. 1 to 18 inclusive except Ref. No. 6)
OA	PGU-1804-A	1	Roller ram group-left hand (includes Ref. Nos. 1 to 18 inclusive except Ref. No. 6)
1	PGF-609	1	Ram connection ball
1A	PGF-1652	2	Ball cap
2	MGF-1992	20	Ball cap shim
3	PGX-1691	4	Tie rod
4	PG-707	1	Base
5	PGF-1687	2	Gasket
6	PGF-1157	1	Outer spreader (no longer furnished. Order Ref. Nos. 6A, 6B and 6C)
6A	PGF-10804	1	Outer spreader
6B	770022	1	Lock washer
6C	726013	1	Jam nut
7	PGF-1158	1	Inner spreader
8	RGF-4378	2	Cup
9	PG-320	1	Piston
10	PGF-1685	1	Cylinder
11	PGF-4488	1	Piston rod
12	PG-1342	1	Head
13	RGF-4382	As req'd.	Chevron packing ring
14	PG-1348	1	Press ring
15	PGF-7025	1	Retainer
16	PGF-6997	1	Felt
17	PGF-1699	1	Wiper
18	PGF-7019	1	Cap

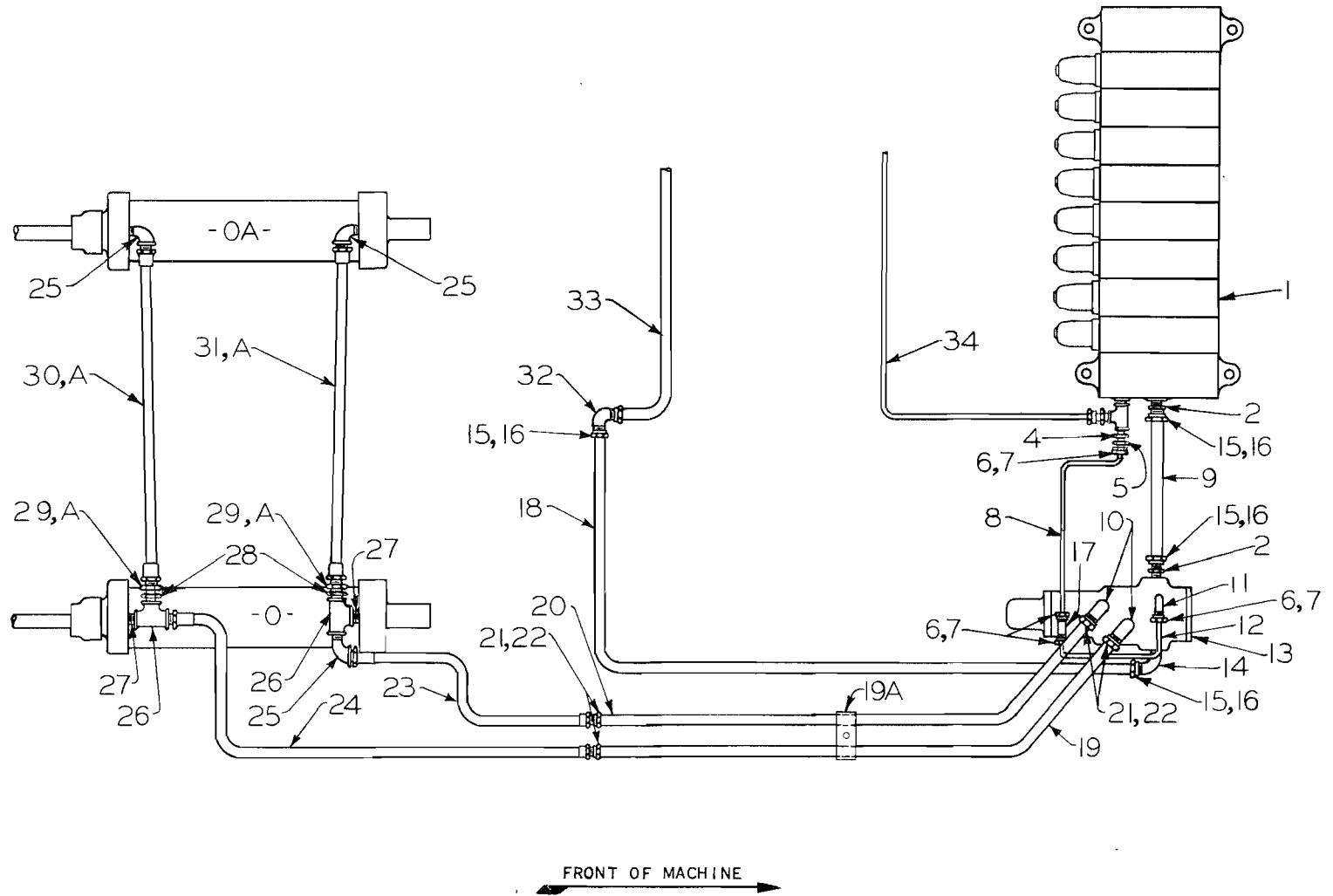
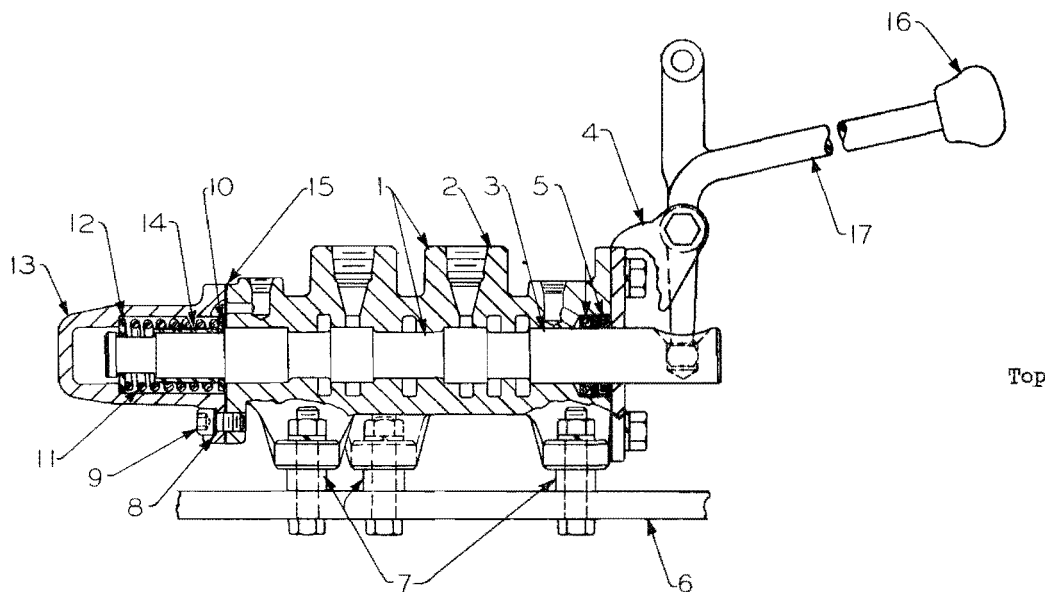

Figure 79. Rear Roller Hydraulic System (Piping Diagram)

REF. NO.	PART NO.	QUANTITY	DESCRIPTION
0		1	Ram group-right hand
0A		1	Ram group-left hand
1		1	Valve bank group
2	PGF-10143-8	2	Male connector
4	526001	1	Reducer bushing
5	PGF-10143-3	1	Male connector
6	PGF-9496-3	4	Coupling sleeve (for 1/4" OD tube)
7	PGF-9497-3	4	Coupling nut (for 1/4" OD tube)
8	PGF-9806	1	Drain line - 1/4" OD x 14-1/4" (approx.) (includes 2 of Ref. Nos. 6 and 7)
9	PGF-9803	1	Return line - 3/4" OD x 9-3/16" (approx.) (includes 2 of Ref. Nos. 15 and 16)
10	PGF-10144-7	2	Elbow
11	PGF-10144-3	1	Elbow
12	PGF-9808	1	Drain line - 1/4" OD x 8-3/4" (approx.) (includes 2 of Ref. Nos. 6 and 7)
13		1	Control valve group
14	PGF-10144-8	1	Elbow
15	PGF-9496-8	4	Coupling sleeve (for 3/4" OD tube)
16	PGF-9497-8	4	Coupling nut (for 3/4" OD tube)
17	PGF-10147-3	1	Tee
18	PGF-9802	1	Return line - 3/4" OD x 19-3/16" (approx.) (includes 2 of Ref. Nos. 15 and 16)
19	PGF-9791	1	Tube - 5/8" OD x 115-1/4" (approx.) (includes 2 of Ref. Nos. 21 and 22)
19A	PGF-7524	2	Tube clamp
20	PGF-9778	1	Tube - 5/8" OD x 116-5/8" (approx.) (includes 2 of Ref. Nos. 21 and 22)
21	PGF-9496-7	4	Coupling sleeve (for 5/8" OD tube)
22	PGF-9497-7	4	Coupling nut (for 5/8" OD tube)
23	PGF-9788	1	* Hydraulic hose - 24-1/4" overall length
24	PGF-9759	1	* Hydraulic hose - 36-1/4" overall length
25	PGF-9537-4	3	Elbow
26	PGF-9539-4	2	Tee
27	532138	2	Pipe nipple
28	PGF-2361	2	Union tail piece (used with PGF-1458 and RGF-5065 hydraulic hoses)
29	PGF-2360	2	Union ring (used with PGF-1458 and RGF-5065 hydraulic hoses)
29A	HCF-362	2	Adapter union (used with PGF-10773 and PGF-10772 hydraulic hoses)
30	PGF-1458	1	Hydraulic hose - 48" exposed rubber (has 1/2" union collar thread one end)
30A	PGF-10773	1	* Hydraulic hose - 51-7/8" overall length (has 1/2" pipe thread both ends)
31	RGF-5065	1	Hydraulic hose - 41-1/2" exposed rubber (has 1/2" union collar thread one end)
31A	PGF-10772	1	* Hydraulic hose - 45-3/8" overall length (has 1/2" pipe thread both ends)
32	PGF-10161-8	1	Elbow
33		1	Regular return line (to tank)
34		1	Return drain line (to tank)

Note: * Hydraulic hose dimensions given are overall lengths including end fittings.



B/M PGU-1801

Figure 80. Rear Roller Hydraulic Control Valve

REF. NO.	PART NO.	QUANTITY	DESCRIPTION
1	PGU-1800	1	Body with valve (includes Ref. Nos. 2 and 3)
2		1	* Valve body
3		1	* Valve plug (movable)
4	PG-1832	1	Valve lever bracket
5	PGF-8946	2	Oil seal
6		1	Valve support plate
7	AJF-3215	3	Valve body spacer
8	HCF-373	4	Washer
9	819133	4	Cap screw-hollow head
10	PGF-8785	1	Washer
11	PGF-8775	1	Valve spring
12	PGF-8780	1	Washer
13	AS-1010	1	Valve spring cap
14	PGF-8781	1	Sl�eve
15	ASF-5105	1	Valve spring cap gasket
16	PG-1400	1	Valve lever ball
17	PGF-9765	1	Valve lever

Note: * Indicates parts not sold separately. Order Ref. No. 1 - PGU-1800, body with valve, from your nearest Austin-Western distributor.

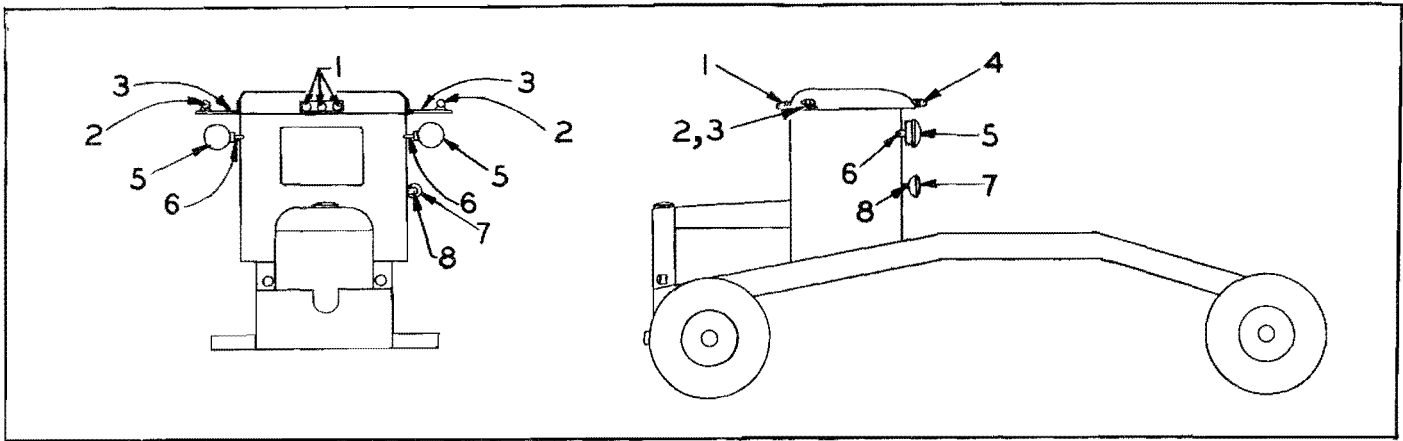

Figure 81. Snow Removal Lights

REF. NO.	PART NO.	QUANTITY	DESCRIPTION
1	PGF-9346	1	Triple identification lights-rear (red)
2	PGF-9347	2	Side clearance light (amber and red)
3	PGF-4742	2	Clearance light bracket
4	PGF-9344	1	Triple identification lights-front (green)
5		2	Relocation of headlight (for giant "V" plow)
6	PGF-10390	2	Light bracket
7	PGF-9358	1	Spot light (for wing)
8	PGF-1090-8	1	Spot light support (welds on)

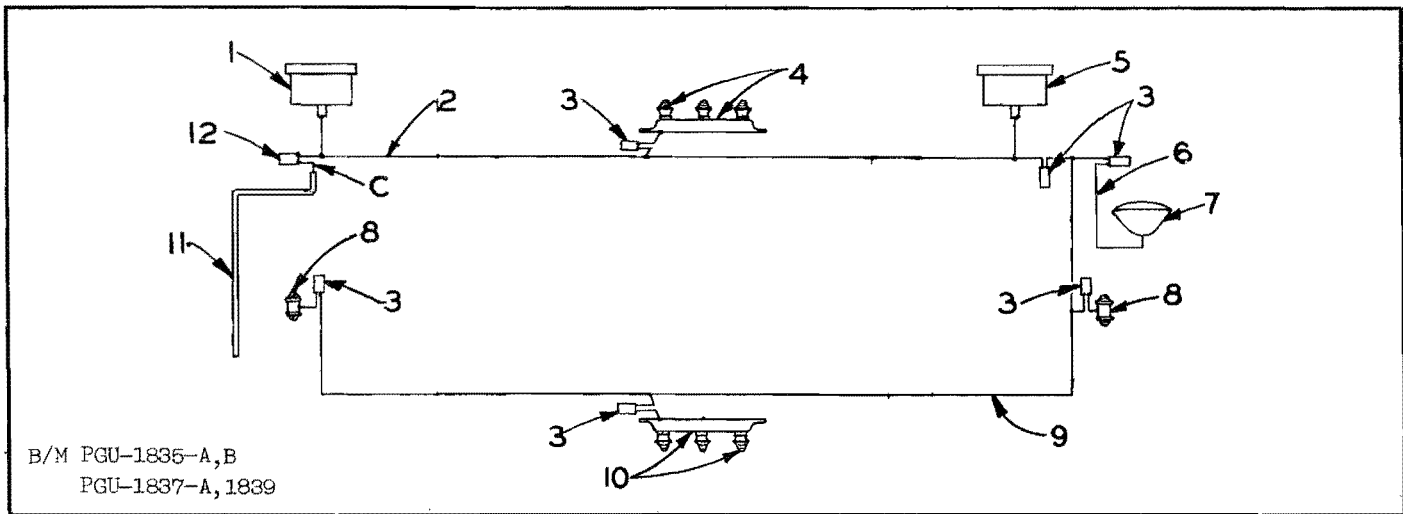
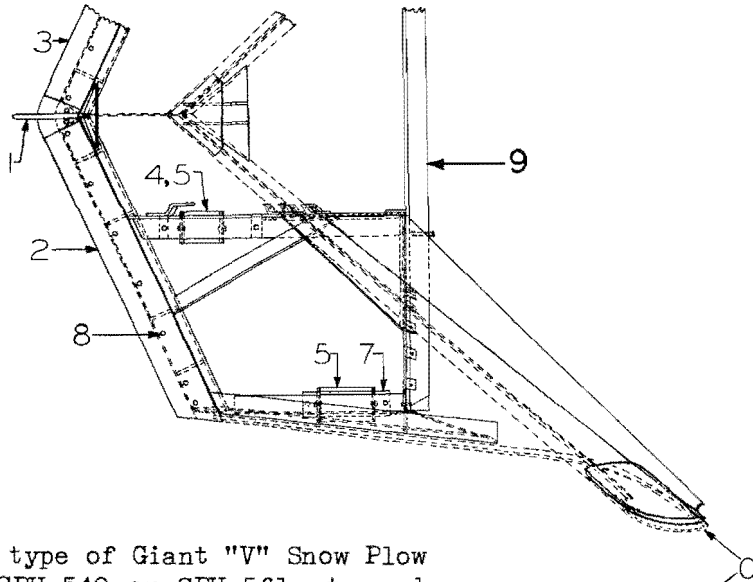
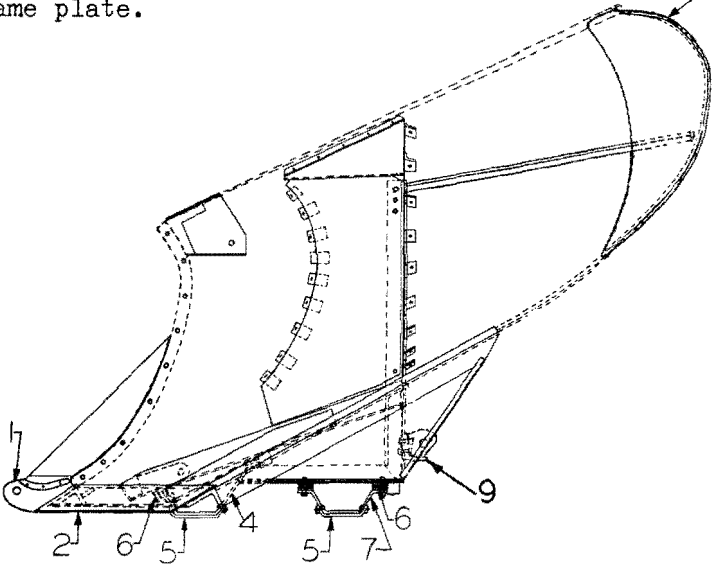

Figure 82. Wiring Diagram for Snow Removal Lights

REF. NO.	PART NO.	QUANTITY	DESCRIPTION
1		1	Headlight-left hand
2	PGF-10396	1	Wire-LH headlight connector to RH headlight
3	PGF-9966	6	Connector
4	PGF-9344	1	Triple identification lights-front (green)
5		1	Headlight-right hand
6	PGF-10039	1	Wire-connector to spot light
7	PGF-9358	1	Spot light (for wing)
8	PGF-9347	2	Side clearance light (amber and red)
9	PGF-10006	1	Wire-RH headlight connector to LH clearance light
10	PGF-9346	1	Triple identification lights-rear (red)
11		1	Wiring harness assembly (regular)
12		1	Connector (regular)



This type of Giant "V" Snow Plow has SPU-540 or SPU-561 stamped on name plate.



B/M SPU-540
SPU-561

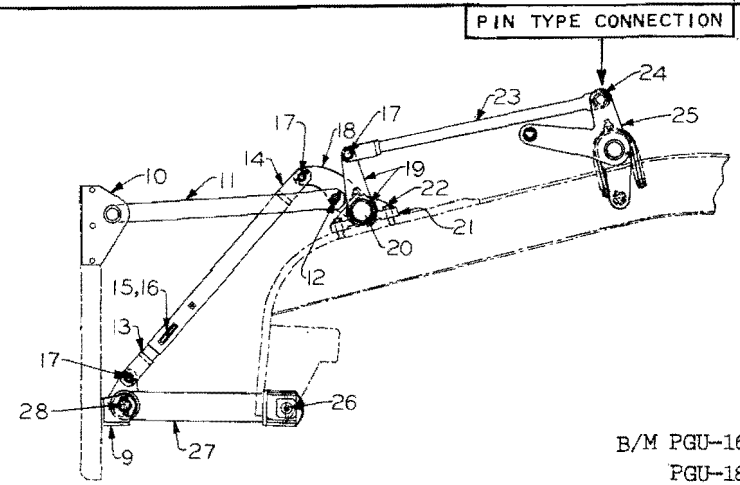

B/M PGU-1688, A
PGU-1807

Lift Mechanism (1st type)
This type for snow plows stamped SPU-540 on name plate.

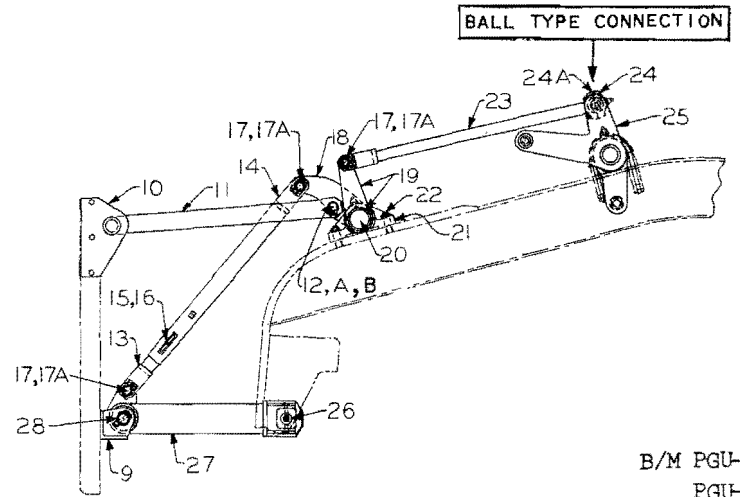

B/M PGU-1946
PGU-1947

Lift Mechanism (2nd type)
This type for snow plows stamped SPU-561 on name plate.

Figure 83. Giant "V" Type Snow Plow

REF. NO.	PART NO.	QUANTITY	DESCRIPTION
0	SPU-548	1	Snow plow group (includes welded "V" and Ref. Nos. 1,2,3,8 and 9)
1	SP-32	1	Nose iron
2	SPF-868	1	Bit-left hand (6" x 3/8" x 59-3/16")
3	SPF-867	1	Bit-right hand (6" x 3/8" x 59-3/16")
4	SPF-929	2	Front runner
5	SPF-931	4	Runner shoe
6	SPF-874	48	Runner shim
7	SPF-930	2	Rear runner
8	RGF-6461	14	Bit bolt
9	SPF-1142	1	Cross angle

Lift Mechanism (1st type)

This type for snow plows stamped SPU-540 on name plate

10	SPF-1059	2	Upper hinge plate
11	SPF-1143	1	"V" frame
12	SPF-1078	1	"V" frame pin
13	SPF-1137	1	Lift bar
14	SPF-1141	1	Lift tube
15	SPF-1085	1	Lift bar pin
16	PGF-10644	2	Washer
17	PGF-9562	3	Pin
18	PGF-9656	1	Arm
19	PGF-9692	1	Lift shaft
20	PG-728	1	Lift shaft nut
21	PG-1815	1	Support
22	741884	4	Cap screw
23	PGF-9696	1	Connecting rod (pin type connection)
24	PGF-9566	1	Collar
25	PGF-9693	1	Scarifier lift shaft
26	PGF-10736	2	Pivot pin
27	SPF-1061	1	Push frame
28	SPF-1056	1	Cross shaft

Lift Mechanism (2nd type)

This type for snow plows stamped SPU-561 on name plate

10	SPF-1059	2	Upper hinge plate
11	SPF-1191	1	"V" frame
12	SPF-1198	1	"V" frame pin
12A	SPF-1193	1	"V" frame connection bushing
12B	PGF-4618	1	"V" frame pin washer
13	SPF-1188	1	Lift bar
14	SPF-1189	1	Lift tube
15	SPF-1085	1	Lift bar pin
16	PGF-10644	2	Washer
17	PGF-10731	3	Pin
17A	SPF-1100	3	Bushing
18	PGF-10734	1	Arm
19	PGF-10732	1	Lift shaft
20	PG-728	1	Lift shaft nut
21	PG-1815	1	Support
22	PGF-10730	4	Stud
23	PGF-10720	1	Connecting rod (ball type connection)
24	PGF-9487	1	Ball cap
24A	MGF-1992	6	Ball cap shim
25	PGF-10712	1	Scarifier lift shaft
26	PGF-10736	2	Pivot pin
27	SPF-1192	1	Push frame
28	SPF-1056	1	Cross shaft

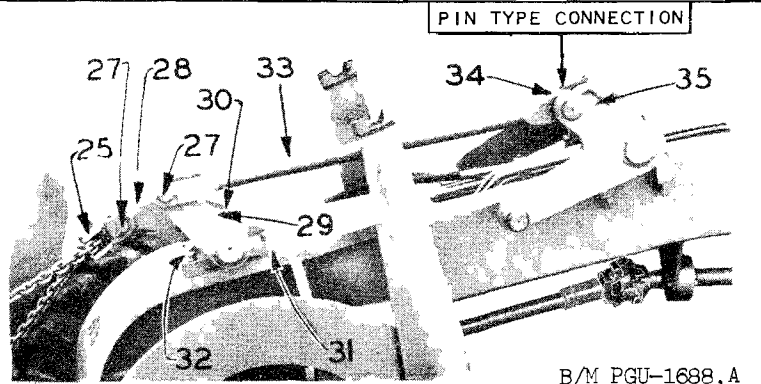

Lift Mechanism (1st type)
This type for snow plows stamped
SPU-541 on name plate.

B/M PGU-1688, A
PGU-1807

This type of One-Way Snow Plow has SPU-541
or SPU-541-A stamped on name plate.

Lift Mechanism (2nd type)
This type for snow plows stamped
SPU-541-A on name plate.

BALL TYPE CONNECTION

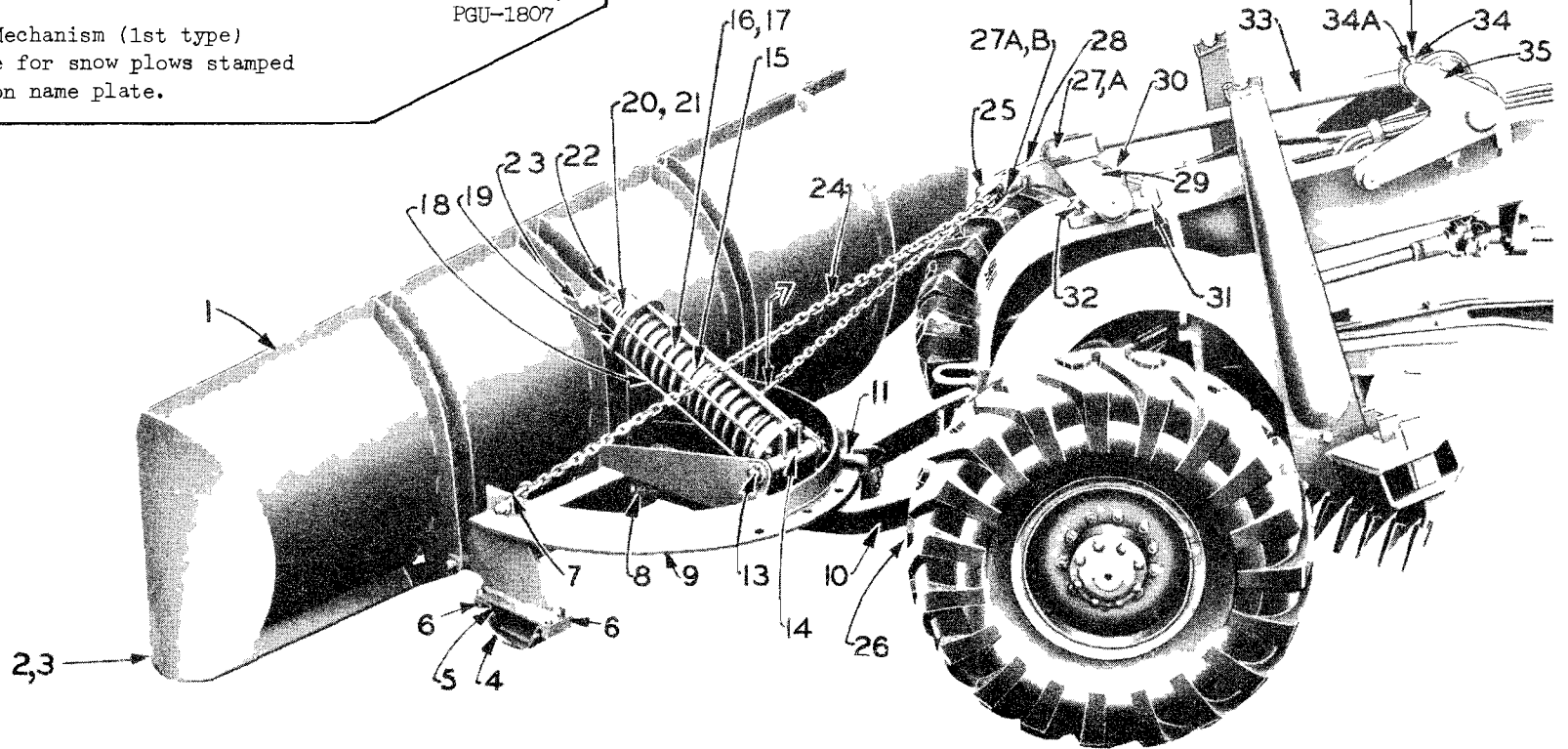

B/M SPU-541, 541-A
PGU-1946, 1947

Figure 84. One-Way Snow Plow

REF. NO.	PART NO.	QUANTITY	DESCRIPTION
1	SPU-550	1	Blade assembly with bit (includes Ref. Nos. 2 and 3)
2	SPF-1049	1	Bit - 1/2" x 6" x 11'
3	RGF-6447	13	Bit bolt
4	SPF-1045	2	Runner shoe
5	SPF-1052	2	Runner
6	SPF-1050	16	Runner spacer
7	SPF-1047	2	Lift chain yoke
8	SP-48	1	Push frame ball cap
9	SPF-1075	1	Circle frame
10	SPF-1051	1	Push frame
11	SPF-1051-8	1	Circle lock pin (welds on)
13	SPF-1074	1	Base pin
14	SPF-1072	1	Spring housing base
15	SPF-1065	1	Blade trip spring-outer
16	SPF-1063	1	Spring tube
17	SPF-1064	1	Blade trip spring-inner
18	SPF-1066	6	Tie rod
19	SPF-1073	1	Spring housing head
20	SPF-1067	1	Spring rod
21	SPF-1069	1	Recoil spring
22	SP-50	1	Spring rod yoke
23	SPF-1068	1	Yoke pin
24	SPF-1124	1	Lift chain

Lift Mechanism (1st type)

This type for snow plows stamped SPU-541 on name plate

25	SP-49	1	Lift chain yoke
26	PGF-10736	2	Push frame pivot pin
27	PGF-9562	2	Pin
28	PGF-9656	1	Arm
29	PGF-9692	1	Lift shaft
30	PG-728	1	Lift shaft nut
31	PG-1815	1	Support
32	741884	4	Cap screw
33	PGF-9696	1	Connecting rod (pin type connection)
34	PGF-9566	1	Collar
35	PGF-9693	1	Scarifier lift shaft

Lift Mechanism (2nd type)

This type for snow plows stamped SPU-541-A on name plate

25	SP-68	1	Lift chain yoke
26	PGF-10736	2	Push frame pivot pin
27	PGF-10731	1	Pin
27A	SPF-1100	2	Bushing
27B	SPF-1194	1	Yoke pin
28	PGF-10734	1	Arm
29	PGF-10732	1	Lift shaft
30	PG-728	1	Lift shaft nut
31	PG-1815	1	Support
32	PGF-10730	4	Stud
33	PGF-10720	1	Connecting rod (ball type connection)
34	PGF-9487	1	Ball cap
34A	MGF-1992	6	Ball cap shim
35	PGF-10712	1	Scarifier lift shaft

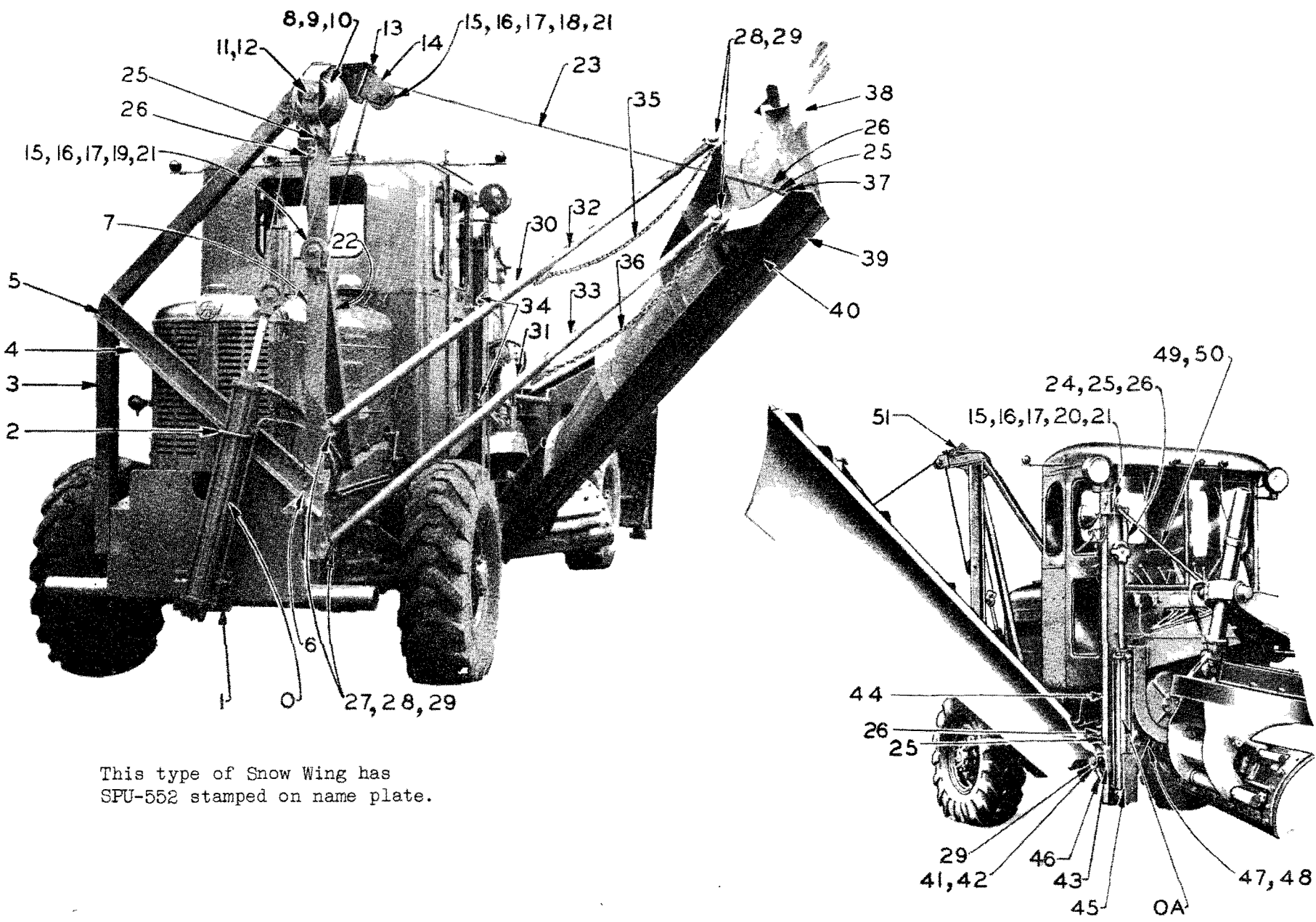

This type of Snow Wing has
SPU-552 stamped on name plate.

B/M SPU-552

Figure 85. Snow Wing

REF. NO.	PART NO.	QUANTITY	DESCRIPTION
0		1	Rear lift ram group
0A		1	Front lift ram group
1	SPF-1102	1	Rear ram ball support
2	SPF-1153	1	"U" bolt
3	SPF-1113	1	Rear mast brace
4	SPF-1151	1	Rear mast cross brace
5	SPF-1164	1	Cross brace spacer-left hand
6	SPF-1165	1	Cross brace spacer-right hand
7	SPF-1101	1	Rear mast
8	SP-65	1	Rear lift pulley
9	SPF-1091	1	Lift pulley "U" bolt
10	SPF-1100	2	Lift pulley bushing
11	SPF-1103	1	Lift pulley shaft
12	SPF-1104	1	Lift pulley spacer
13	SPF-1160	1	Sheave box shaft
14	SPF-906	1	Sheave box
15	SP-52	3	Pulley
16	RGF-5500	60	Bearing roller
17	RGF-5499	3	Spacer bushing
18	SPF-1158	1	Pulley cap screw
19	SPF-1159	1	Pulley cap screw
20	SPF-1099	1	Pulley cap screw
21	734009	3	Slotted nut
22	SPF-1107	1	Rear upright brace
23	SPF-1115	1	* Rear lift cable - 3/8" x 31'
24	SPF-1119	1	* Front lift cable - 3/8" x 12'
25	860005	4	Cable thimble
26	906004	8	Cable clamp
27	PGF-609	2	Ball
28	PGF-1652	4	Ball cap
29	MGF-1992	52	Ball cap shim
30	SPF-1125	1	Brace tube-upper
31	SPF-1126	1	Brace tube-lower
32	SPF-1097	1	Brace tube shaft-upper
33	SPF-1127	1	Brace tube shaft-lower
34	SPF-781	2	Handle pin
35	SPF-1120	1	Brace tube chain-upper
36	SPF-1114	1	Brace tube chain-lower
37	SPF-1157	1	Cable bracket
38	SPF-1105	1	Snow wing
39	SPF-1026	1	Bit - 1/2" x 6" x 11'-4"
40	RGF-6447	13	Bit bolt
41	SP-62	1	Ball cap
42	SPF-1117	2	Ball cap stud
43	SPF-1156	1	Snow wing lift slide
44	SPF-1090	1	Front mast
45	SPF-1150	1	Front ram guard
46	SPF-1148	1	Front mast lower brace
47	SPF-1149	1	Front mast cross brace
48	SP-63	1	Cross brace bracket (not illustrated)
49	SPF-1152	1	Front mast brace rod
50	SP-64	1	Brace rod anchor (not illustrated)
51	SPF-1202	1	Safety chain clevis

Note: * Indicates (6 x 37) plow steel, regular lay (right lay), hemp center.

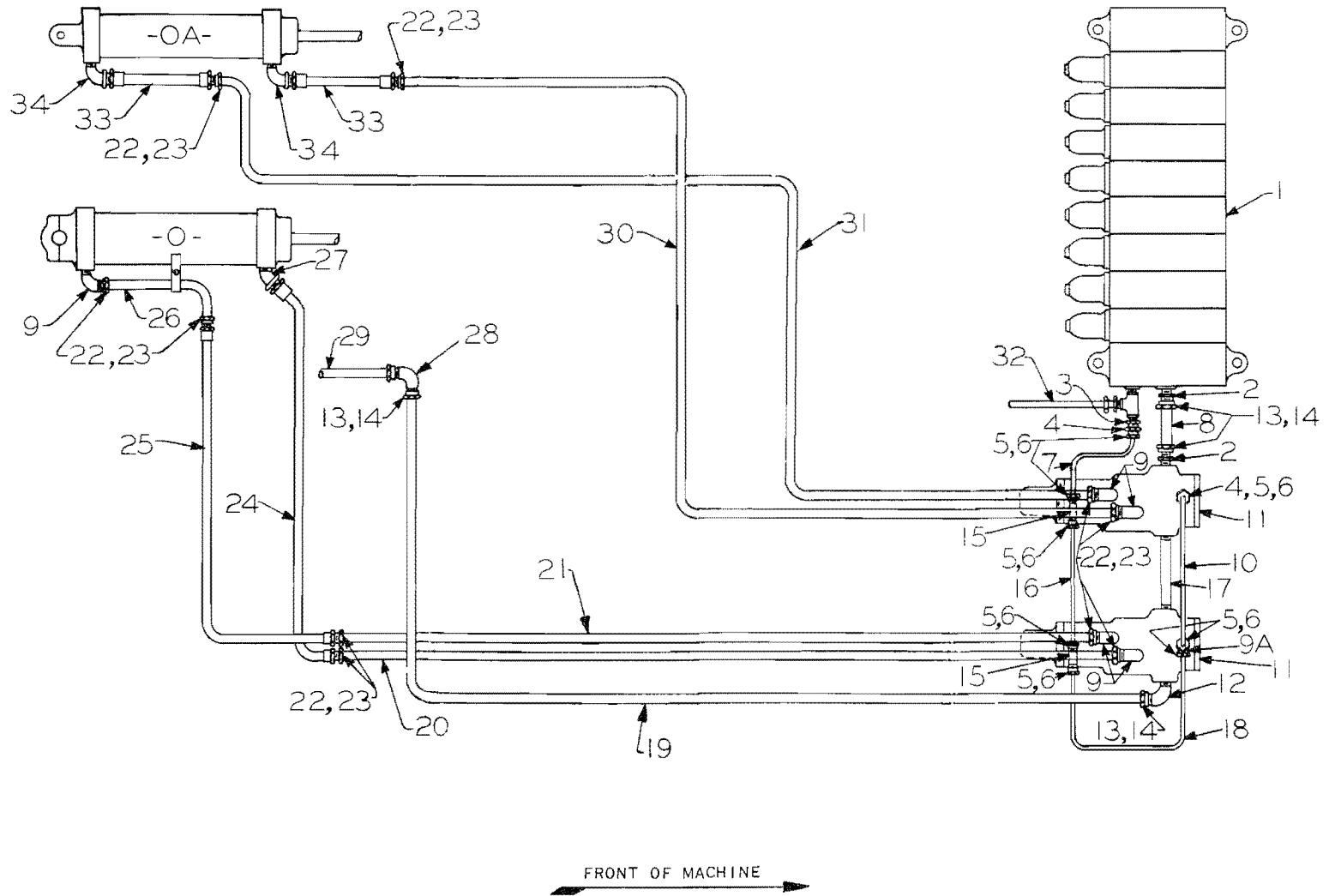

Figure 86. Snow Wing Hydraulic System (Piping Diagram)

REF. NO.	PART NO.	QUANTITY	DESCRIPTION
0		1	Rear lift ram group
0A		1	Front lift ram group
1		1	Valve bank group
2	PGF-10143-8	2	Male connector
3	526001	1	Reducer bushing
4	PGF-10143-3	2	Male connector
5	PGF-9496-3	8	Coupling sleeve (for 1/4" OD tube)
6	PGF-9497-3	8	Coupling nut (for 1/4" OD tube)
7	PGF-10155	1	Drain line - 1/4" OD x 7-3/8" (approx.) (includes 2 of Ref. Nos. 5 and 6)
8	PGF-9809	1	Return line - 3/4" OD x 2-7/8" (approx.) (includes 2 of Ref. Nos. 13 and 14)
9	PGF-10144-7	5	Elbow
9A	PGF-10146-3	1	Tee
10	PGF-9807	1	Drain line - 1/4" OD x 9-13/16" (approx.) (includes 2 of Ref. Nos. 5 and 6)
11		2	Control valve group
12	PGF-10144-8	1	Elbow
13	PGF-9496-8	4	Coupling sleeve (for 3/4" OD tube)
14	PGF-9497-8	4	Coupling nut (for 3/4" OD tube)
15	PGF-10147-3	2	Tee
16	PGF-10162	1	Drain line - 1/4" OD x 8-1/16" (approx.) (includes 2 of Ref. Nos. 5 and 6)
17	532192	1	Nipple
18	PGF-9808	1	Drain line - 1/4" OD x 8-3/4" (approx.) (includes 2 of Ref. Nos. 5 and 6)
19	PGF-9802	1	Return line - 3/4" OD x 19-3/16" (approx.) (includes 2 of Ref. Nos. 13 and 14)
20	PGF-9791	1	Tube - 5/8" OD x 115-1/4" (approx.) (includes 2 of Ref. Nos. 22 and 23)
21	PGF-9778	1	Tube - 5/8" OD x 116-5/8" (approx.) (includes 2 of Ref. Nos. 22 and 23)
22	PGF-9496-7	10	Coupling sleeve (for 5/8" OD tube)
23	PGF-9497-7	10	Coupling nut (for 5/8" OD tube)
24	SPF-1128	1	Hydraulic hose - 22-3/8" overall length
25	SPF-1131	1	Hydraulic hose - 28-7/8" overall length
26	SPF-1129	1	Tube - 5/8" OD x 39-1/4" (approx.) (includes 2 of Ref. Nos. 22 and 23)
27	PGF-9865-4	1	Elbow
28	PGF-10161-8	1	Elbow
29		1	Regular return line (to tank)
30	SPF-1162	1	Tube - 5/8" OD x 47" (approx.) (includes 2 of Ref. Nos. 22 and 23)
31	SPF-1163	1	Tube - 5/8" OD x 47" (approx.) (includes 2 of Ref. Nos. 22 and 23)
32		1	Return drain line (to tank)
33	ASF-5423	2	Hydraulic hose - 12-3/4" overall length
34	PGF-9537-4	2	Elbow
	PGF-7524	5	Tube clamp (not illustrated)
	SPF-1123	1	Tube spacer (not illustrated)

Note: Hydraulic hose dimensions given are overall lengths including end fittings.

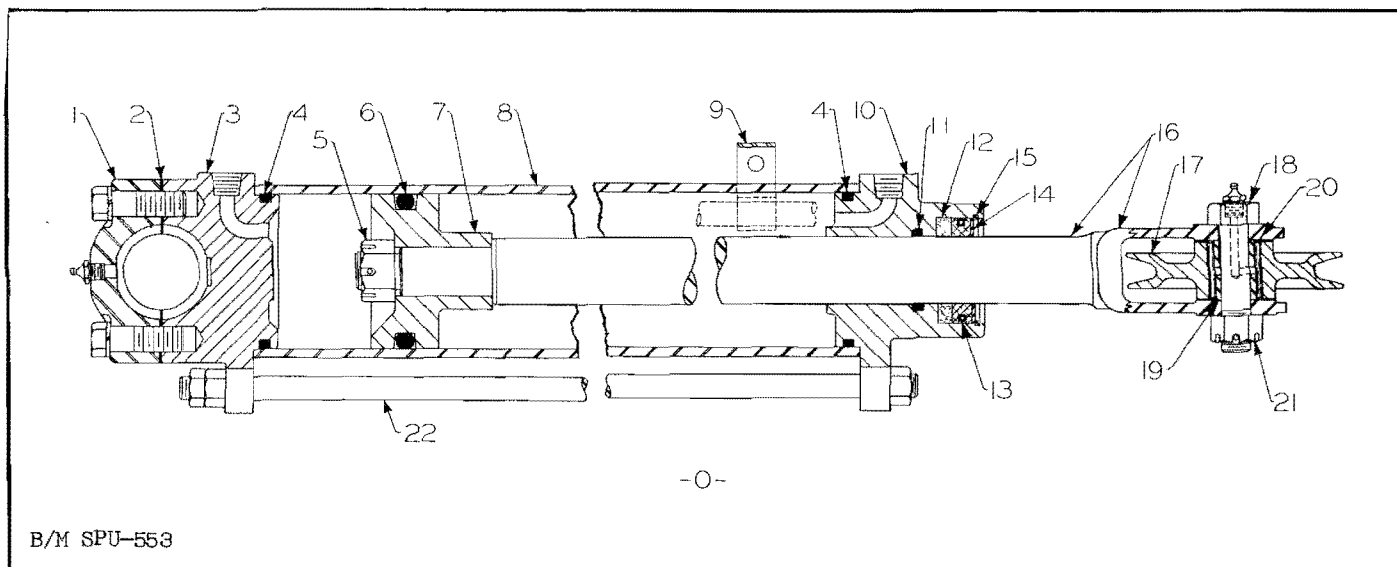

Figure 87. Snow Wing Rear Lift Ram

REF. NO.	PART NO.	QUANTITY	DESCRIPTION
0	SPU-553	1	Snow wing rear lift ram group (includes Ref. Nos. 1 to 22 inclusive)
1	PGF-9487	1	Ball cap
2	MGF-1992	6	Ball cap shim
3	SP-57	1	Base
4	PGF-9648-1	2	"O" ring
5	734011	1	Slotted nut
6	PGF-9648-11	1	"O" ring
7	SP-53	1	Piston
8	SPF-1110	1	Cylinder
9	SPF-1121	1	Pipe clamp
10	SP-51	1	Head
11	PGF-9648-9	1	"O" ring
12	SPF-1122	1	Felt
13	PGF-9225	1	Wiper
14	SPF-1098	1	Washer
15	SPF-1094	1	Snap ring
16	SPF-1116	1	Piston rod
17	SP-52	1	Pulley
18	SPF-1099	1	Cap screw
19	RGF-5499	1	Spacer bushing
20	RGF-5500	20	Bearing roller
21	734009	1	Slotted nut
22	SPF-1111	4	Tie rod

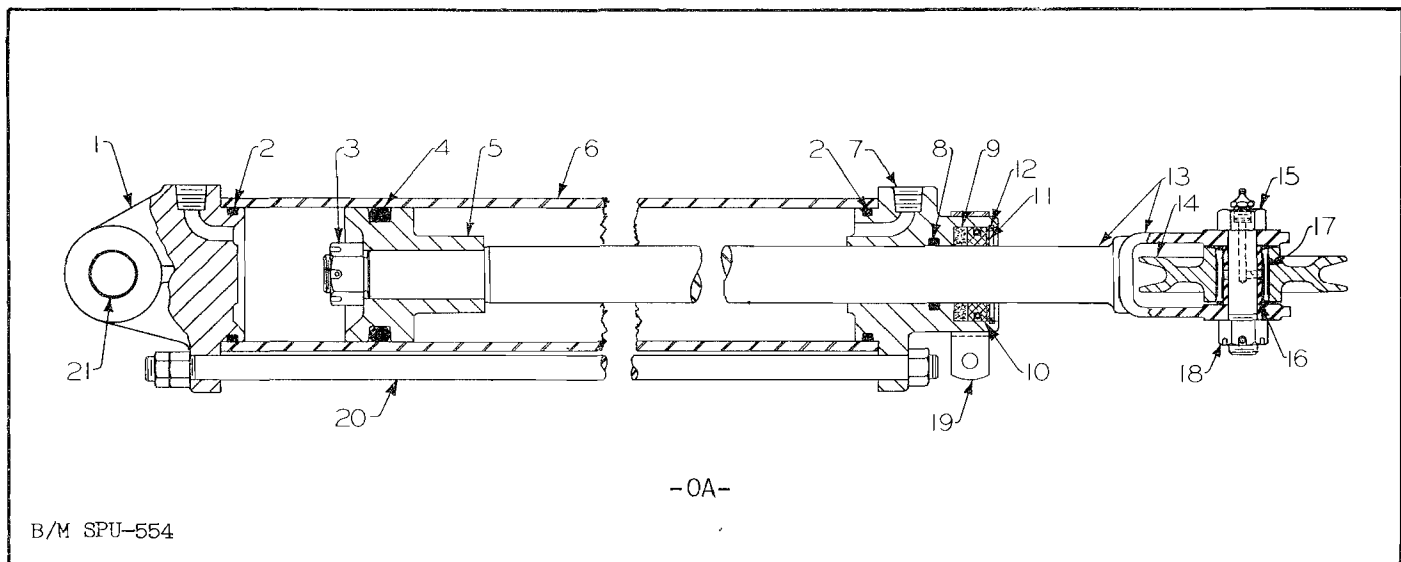

Figure 88. Snow Wing Front Lift Ram

REF. NO.	PART NO.	QUANTITY	DESCRIPTION
0A	SPU-554	1	Snow wing front lift ram group (includes Ref. Nos. 1 to 20 inclusive)
1	SP-59	1	Base
2	PGF-9648-13	2	"O" ring
3	734011	1	Slotted nut
4	PGF-9648-12	1	"O" ring
5	SP-55	1	Piston
6	SPF-1108	1	Cylinder
7	SP-56	1	Head
8	PGF-9648-10	1	"O" ring
9	PGF-6997	1	Felt
10	PGF-1699	1	Wiper
11	SPF-1093	1	Washer
12	SPF-1095	1	Snap ring
13	SPF-1112	1	Piston rod
14	SP-52	1	Pulley
15	SPF-1099	1	Cap screw
16	RGF-5499	1	Spacer bushing
17	RGF-5500	20	Bearing roller
18	734009	1	Slotted nut
19	SPF-1096	1	Clamp
20	SPF-1109	4	Tie rod
21	SPF-1118	1	Ram support pin

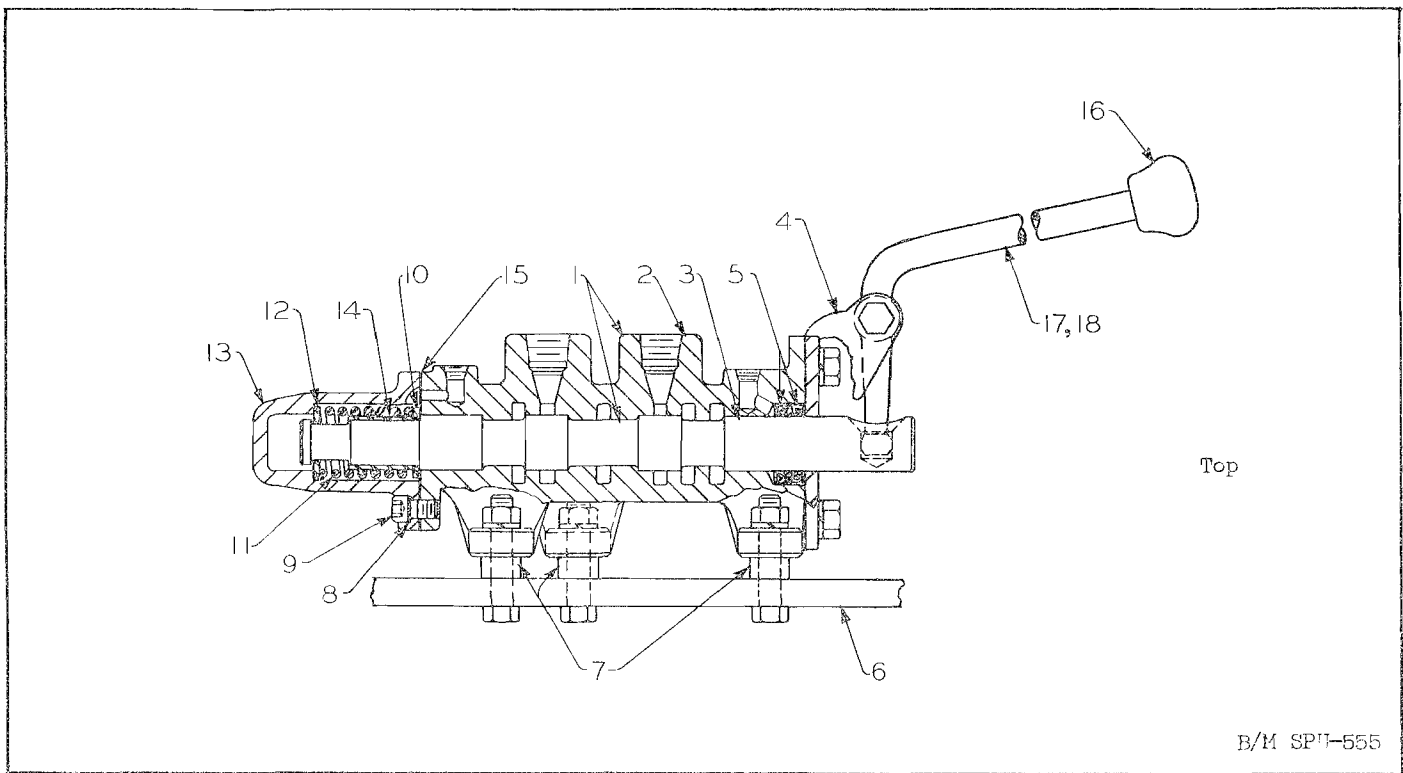

Figure 89. Snow Wing Hydraulic Control Valve

REF. NO.	PART NO.	QUANTITY	DESCRIPTION
1	PGU-1800	1	Body with valve (includes Ref. Nos. 2 and 3)
2		1	* Valve body
3		1	* Valve plug (movable)
4	PG-1832	1	Valve lever bracket
5	PGF-8946	2	Oil seal
6		1	Valve support plate
7	AJF-3215	4	Valve body spacer
8	HCF-373	4	Washer
9	819133	4	Cap screw-hollow head
10	PGF-8785	1	Washer
11	PGF-8775	1	Valve spring
12	PGF-8780	1	Washer
13	AS-1010	1	Valve spring cap
14	PGF-8781	1	Sleeve
15	ASF-5105	1	Valve spring cap gasket
16	PG-1400	1	Valve lever ball
17	SPF-1135	1	Valve lever-rear ram control
18	SPF-1136	1	Valve lever-front ram control

Note: * Indicates parts not sold separately. Order Ref. No. 1 - PGU-1800, body with valve, from your nearest Austin-Western distributor.

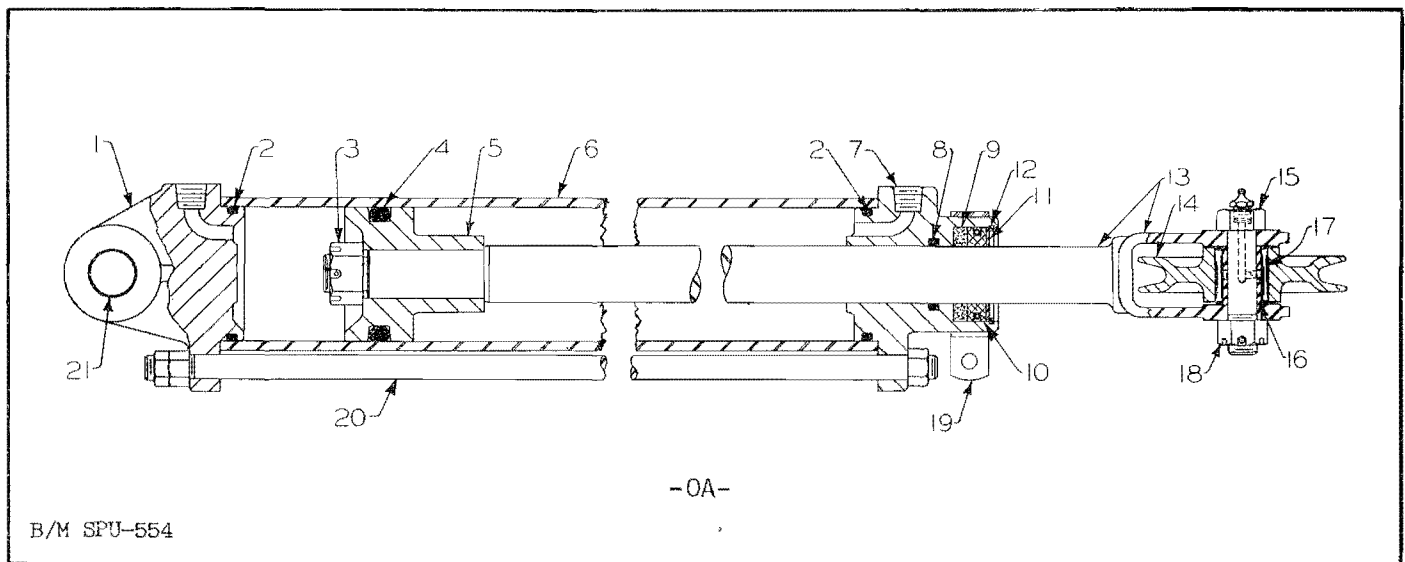
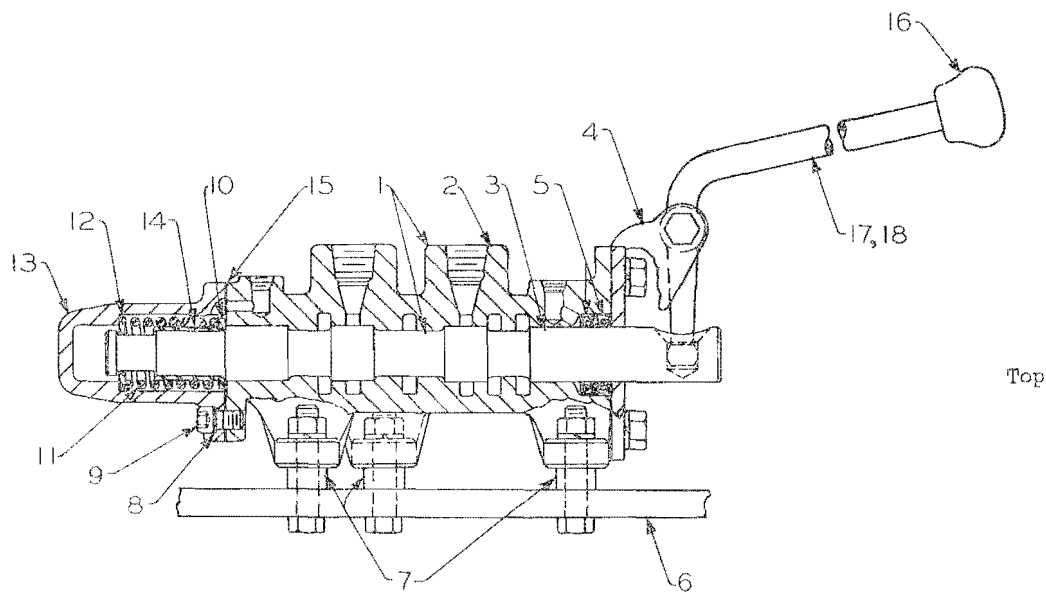

Figure 88. Snow Wing Front Lift Ram

REF. NO.	PART NO.	QUANTITY	DESCRIPTION
0A	SPU-554	1	Snow wing front lift ram group (includes Ref. Nos. 1 to 20 inclusive)
1	SP-59	1	Base
2	PGF-9648-13	2	"O" ring
3	734011	1	Slotted nut
4	PGF-9648-12	1	"O" ring
5	SP-55	1	Piston
6	SPF-1108	1	Cylinder
7	SP-56	1	Head
8	PGF-9648-10	1	"O" ring
9	PGF-6997	1	Felt
10	PGF-1699	1	Wiper
11	SPF-1093	1	Washer
12	SPF-1095	1	Snap ring
13	SPF-1112	1	Piston rod
14	SP-52	1	Pulley
15	SPF-1099	1	Cap screw
16	RGF-5499	1	Spacer bushing
17	RGF-5500	20	Bearing roller
18	734009	1	Slotted nut
19	SPF-1096	1	Clamp
20	SPF-1109	4	Tie rod
21	SPF-1118	1	Ram support pin



B/M SP¹¹-555

Figure 99. Snow Wing Hydraulic Control Valve

REF. NO.	PART NO.	QUANTITY	DESCRIPTION
1	PGU-1800	1	Body with valve (includes Ref. Nos. 2 and 3)
2		1	* Valve body
3		1	* Valve plug (movable)
4	PG-1832	1	Valve lever bracket
5	PGF-6946	2	Oil seal
6		1	Valve support plate
7	AJF-3215	4	Valve body spacer
8	HCF-373	4	Washer
9	819133	4	Cap screw-hollow head
10	PGF-8785	1	Washer
11	PGF-8775	1	Valve spring
12	PGF-8780	1	Washer
13	AS-1010	1	Valve spring cap
14	PGF-8781	1	Sleeve
15	ASF-5105	1	Valve spring cap gasket
16	PG-1400	1	Valve lever ball
17	SPF-1135	1	Valve lever-rear ram control
18	SPF-1136	1	Valve lever-front ram control

Note: * Indicates parts not sold separately. Order Ref. No. 1 - PGU-1800, body with valve, from your nearest Austin-Western distributor.

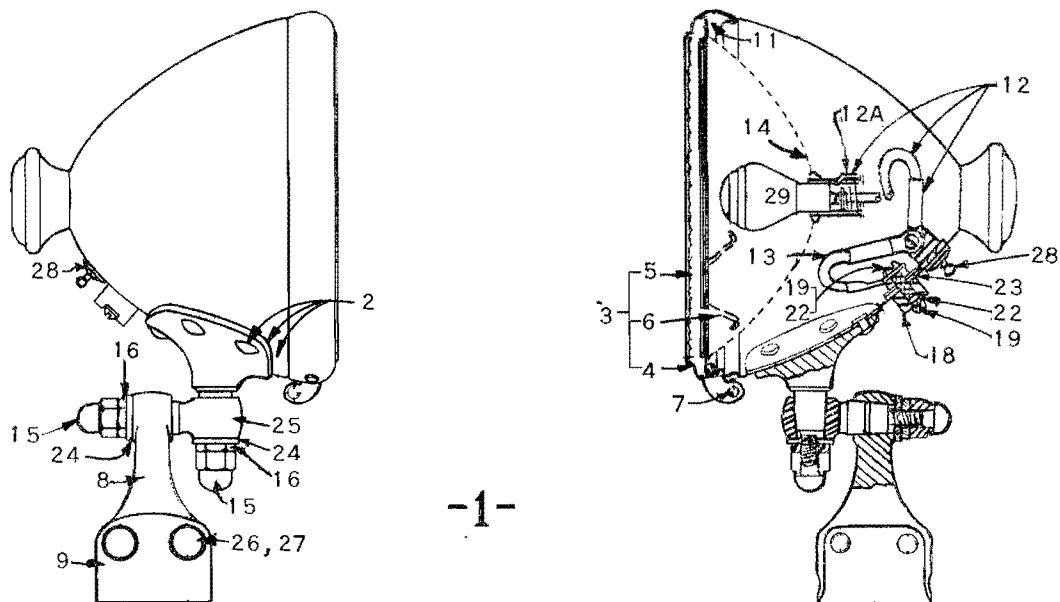

-1-

Figure 90. Snow Wing Spot Light

REF. NO.	PART NO.	QUANTITY	DESCRIPTION
1	PGF-9358	1	Spot light, complete
2	GLCO-922508	1	Body group
3	GLCO-915243	1	Molding group with lens
4	GLCO-5934365	1	Molding group
5	GLCO-914992	1	Lens
6	GLCO-914255	2	Lens retaining spring
7	GLCO-911636	1	Molding screw
8	GLCO-915005	1	Mounting bracket
9	GLCO-915006	1	Mounting bracket clamp
11	GLCO-919238	1	Reflector gasket
12	GLCO-915000	1	Socket wiring group
12A	GLCO-913447	1	Socket retaining spring
13	GLCO-922510	1	Wiring group-switch to terminal
14	GLCO-914493	1	Reflector group with gasket (includes Ref. No. 11)
15	GLCO-915040	2	Blind nut
16	GLCO-915008	2	Mounting nut
18	GLCO-922786	1	Terminal plate
19	GLCO-121749	2	Terminal screw
22	GLCO-138530	2	Terminal lock washer
23	GLCO-922785	1	Terminal spring
24	GLCO-915007	2	Flat washer
25	GLCO-915004	1	Swivel shaft
26	GLCO-103321	2	Lock washer
27	GLCO-122145	2	Hex head screw
28	GLCO-915041	1	Switch group
29	GESC-93	1	Light bulb (15CP-SC-12-16V)

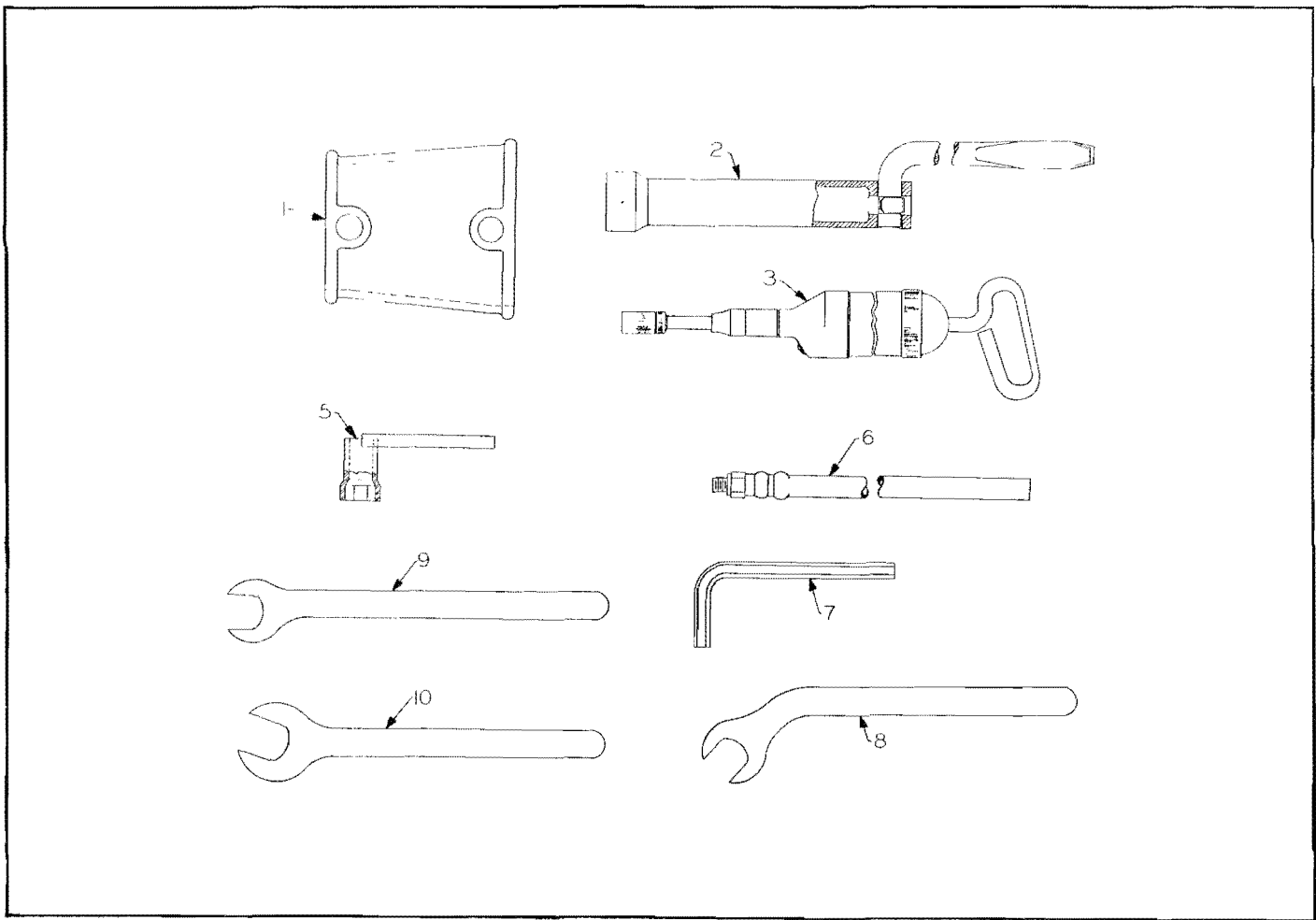

Figure 91. Tools

REF. NO.	PART NO.	QUANTITY	DESCRIPTION
1	PG-934	1	Wheel bearing nut wrench
2	PGF-6510	1	Wheel stud wrench
3	PGF-9875	1	Grease gun
5	PGF-9371	1	Bleeder hose wrench-brake cylinder
6	PGF-9370	1	Bleeder hose-brake cylinder
7	HCF-301	1	Hollow head cap screw wrench-hydraulic control valves
8	PGF-10149	1	Coupling wrench (1-1/8" jaw opening) for 5/8" fitting
9	PGF-10150	1	Coupling wrench (1-1/8" jaw opening) for 5/8" fitting
10	PGF-10148	1	Coupling wrench (1-1/4" jaw opening) for 3/4" fitting

NUMERICAL INDEX

Part No.	Page	Part No.	Page	Part No.	Page
#		312549	7, 47	727011	10, 52, 53
		312743	33	734009	113, 116
434-1	81	312814	10, 52, 53		117
434-2	81	312836	9, 49, 51	734010	12
434-3	81		89	734011	17, 116
470-1	82	312888	10, 52, 53		117
470-2	82	312991	7, 47	734013	79
470-3	82	313071	47	737010	96
021003	30	313098	7	737012	15
034010	69	313190	33	734013	15A, 77
034012	57A	313208	47	737007	63
034016	63	313209	7, 47	737008	54
034103	37	313322	33	737010	97
034105	57A, 64	313366	10, 52, 53	739187	37
064001	59	313380	9, 49, 51	740003	64, 68
064456	9, 49, 51	313382	89	741884	77, 109
111001	67	313407	10, 52, 53		111
111009	61	313448	7, 47	742166	58, 101
111010	31, 42, 59	314050	96	742323	58
111011	85	314058	92	742329	91
111012	43	314060	25	742887	19
164032	30	318180	89	742890	19, 19B
194010	89	318446	30	755095	35
194020	96	461014	61	755153	19, 19B
194026	92	525001	42, 85	755288	19, 19B
194034	89	525004	57	758058	17
194066	85	526001	37, 64, 99	758094	13, 13A
194070	95		105, 115	758148	14
194074	92	532046	57A	762004	91
194092	91	532138	57, 99, 105	765006	40
194134	89	532192	115	770020	12
195035	89	534006	69	770022	14, 54, 103
195036	89	537002	57A	778009	67
311167	30, 42	556101	69	778010	58, 101
311169	96	556121	69	778011	58, 91
311191	85	558004	99	778015	14
311203	85	563001	85	778021	96
311243	42	563852	69	782004	82, 100
311306	85	564051	69	782005	35
311314	85, 95	568001	71	782010	43
311322	31, 33	572359	89	783004	21, 82, 100
311337	7	575143	33	783005	21, 35, 40
311367	33, 89, 91	708803	23, 23A		64
311368	31	713128	35	783007	43
311376	91	722002	58, 101	786005	21
311429	31	722003	58, 91	788007	21
311447	31	722007	13A, 14	789004	21
311451	89	724007	13A	789006	21
311596	30	726013	14, 54, 103	810001	57A
311598	85	726015	54	810004	31
311599	94	727001	68	810005	34
312155	47	727005	63	816003	71
312245	7	727007	7, 13, 47	819133	60, 100
312514	33	727009	34		106, 118
312547	47	727010	12	830004	71

NUMERICAL INDEX

Part No.	Page	Part No.	Page	Part No.	Page
835001	37			BTF-725	47
835006	71	B P C O		BTF-739	47
835007	71	BPCO-70-S-4	39	BTF-743	47, 89, 91
840003	71, 85	BPCO-23969	39	BTF-745	47
840005	71	BPCO-24028	39	BTF-746	47
840006	71	BPCO-24784	39	BTF-747	47
856007	85	BPCO-24959	39	BTF-749	47
860005	81, 113	BPCO-25539	39	BTF-831	10, 52, 53
884008	69	BPCO-25831	39	BTF-832	7, 47
906004	81, 113	BPCO-26114	39	BTF-872	42
01-21351	92	BPCO-28354	39	BTF-890	7, 47
03-46796	94	BPCO-29251	41	BTF-904	47
03-46798	94	BPCO-29258	41	BTF-925	89
		BPCO-30152	39	BTF-926	89
A J F		BPCO-32934	39	BTF-957	49
AJF-616	64	BPCO-34121	39		
AJF-644	64	BPCO-35424	39	B T X	
AJF-2772	71	BPCO-36170	39	BTX-59	47
AJF-3100	65	BPCO-37092	39		
AJF-3215	100, 106	BPCO-45629	39	C A F	
	118	BPCO-46770	39	CAF-873	95
		BPCO-48098	39	CAF-998	37
A S		BPCO-48202	39		
AS-1010	100, 106	BPCO-48205	39	C S F	
	118	BPCO-48207	39	CSF-948	57B
		BPCO-901008	39	CSF-1223	92
		BPCO-901220	39		
		BPCO-901221	39	D C	
		BPCO-901626-K6	39	DC-P-1517	66
				DC-P-2247	66
A S F		B R		DC-P-3516	66
ASF-3267	95	BR-50	102	DC-P-4886	66
ASF-3268	31			DC-P-5653	66
ASF-3678	21	B R F		DC-P-5736	66
ASF-3784	17	BRF-693	47	DC-P-6834	66
ASF-3882	74	BRF-1104	99	DC-P-7048	66
ASF-4604	82	BRF-1309	85	DC-P-7059	66
ASF-5057	39	BRF-1546	63	DC-P-7831	66
ASF-5105	73, 100	BRF-1894	31		
	118	BRF-2139	85	G C	
ASF-5372	73			GC-745	71
ASF-5423	115	B T			
ASF-5451	21, 39	BT-82	97	G E S C	
ASF-5766	57A			GESC-67	73
ASF-5883-2	5	B T F		GESC-93	119
ASF-5883-3	5	BTF-517	5		
ASF-5883-4	5	BTF-708	47	G L C O	
ASF-5884-2	5	BTF-721	47	GLCO-103321	119
ASF-5884-3	5	BTF-722	47		
ASF-5884-4	5	BTF-723	47		
		BTF-724	47		
B D F					
BDF-345	35				

NUMERICAL INDEX

Part No.	Page	Part No.	Page	Part No.	Page	
GLCO-103323	74	I H C		MGF-1992	109, 111	
GLCO-120371	74				113, 116	
GLCO-121749	119		IHC-8081-D	73	MGF-2454	75
GLCO-122145	119		IHC-8120-DA	63	MGF-2703	43
GLCO-138530	119		IHC-10319-D	63	MGF-2950	64
GLCO-142454	74		IHC-20586-D	65		
GLCO-5934365	119		IHC-21259-D	63	M S	
GLCO-911636	119		IHC-24943-D	42	MS-380	5
GLCO-912206	74		IHC-29538-D	64	MS-381	5
GLCO-912711	74		IHC-32332-D	42		
GLCO-913220	74		IHC-32333-D	42		
GLCO-913447	74, 119		IHC-38026-DMX	64	M S F	
GLCO-914255	74, 119		IHC-47490-D	63	MSF-853	40
GLCO-914493	119		IHC-50273-DB	63	MSF-1775	5
GLCO-914525	74		IHC-50529-D	64		
GLCO-914526	74		IHC-50677-D	64		
GLCO-914529	74		IHC-50891-D	73		
GLCO-914530	74		IHC-50892-DA	73	M U J C O	
GLCO-914531	74		IHC-50893-D	65	MUJCO-6X111	55
GLCO-914533	74		IHC-51774-D	67	MUJCO-863-J	24
GLCO-914535	74		IHC-54857-DA	63	MUJCO-949-J	55
GLCO-914537	74		IHC-58220-DX	73	MUJCO-950-J	55
GLCO-914992	119		IHC-59912-DM	63	MUJCO-1473-J	24
GLCO-915000	119		IHC-64643-D	64	MUJCO-1479-J	24
GLCO-915004	119		IHC-65314-D101	71	MUJCO-2176-J	55
GLCO-915005	119		IHC-250332R91	71	MUJCO-112-3000	90
GLCO-915006	119		IHC-250335R11	71	MUJCO-114-3000	90
GLCO-915007	119		IHC-250336R1	71	MUJCO-113-3000	90
GLCO-915008	119		IHC-250337R1	71	MUJCO-114-3008	90
GLCO-915040	119		IHC-250670R91	63	MUJCO-113-3012	90
GLCO-915041	119		IHC-251112R1	64	MUJCO-42-3455	90
GLCO-915243	119		IHC-251209R11	71	MUJCO-3536-J	27
GLCO-919238	119		IHC-252459R11	42	MUJCO-3543-J	27
GLCO-922508	119		IHC-252468R91	71	MUJCO-3544-J	27
GLCO-922510	119		IHC-252474R11	42	MUJCO-3549-J	90
GLCO-922785	119		IHC-253424R11	71	MUJCO-3550-J	27
GLCO-922786	119		IHC-254753R1	63	MUJCO-3551-J	24, 26, 55
					MUJCO-3562-J	24, 26, 55
H C			K R F		MUJCO-3565-J	90
HC-23	13		KRF-369	85	MUJCO-3571-J	24, 26, 55
HC-47	58				MUJCO-3747-J	55
					MUJCO-3786-J	90
					MUJCO-3922-J	90
H C F			L R C		MUJCO-42-4276	27
HCF-197	13		LRC-36-585	85	MUJCO-42-4333	55
HCF-198	13				MUJCO-4369-J-278	27
HCF-200	13, 13A		M G F		MUJCO-4375-J-178	55
HCF-301	120		MGF-445	81	MUJCO-42-4614	90
HCF-334	58		MGF-1185	75	MUJCO-112-5003	27
HCF-362	57, 99, 105		MGF-1558	17	MUJCO-113-5003	27
HCF-368	58		MGF-1992	12, 14, 15	MUJCO-114-5014	27
HCF-373	60, 100			15A, 19, 19B	MUJCO-5116-J	27, 30, 42
	106, 118			54, 75, 77	MUJCO-5320-J	90
				79, 97, 103	MUJCO-5496-J	7, 24, 25
						26, 47, 55

NUMERICAL INDEX

Part No.	Page	Part No.	Page	Part No.	Page
MUJCO-5550-J	90	PG-970	39	PG-1682	33
MUJCO-5551-J	90	PG-991	102	PG-1683	33
MUJCO-5641-J	89, 90	PG-1017	89	PG-1686	42
MUJCO-5642-J	85, 90	PG-1028	95	PG-1688	31, 35
MUJCO-6080-J	33, 55	PG-1045	89	PG-1692	33
MUJCO-6A-7000	55	PG-1048	89	PG-1698	63
MUJCO-113-7002	24, 26, 55	PG-1049	89	PG-1699	63
MUJCO-112-7004	24, 26, 55	PG-1050	89	PG-1709	77, 79
MUJCO-114-7011	26	PG-1053	89	PG-1713	12
MUJCO-114-7012	24, 26, 55	PG-1054	89	PG-1731	31
MUJCO-2-7015	55	PG-1055	96	PG-1732	31, 35
MUJCO-6A-7017	24	PG-1058	85	PG-1734	37
MUJCO-7169-J	26, 33	PG-1059	97	PG-1735	37
MUJCO-7174-J	26	PG-1060	91	PG-1736	31
		PG-1061	91	PG-1737	30
		PG-1062	91	PG-1738	30
		PG-1068-X	91	PG-1739	30
		PG-1074	63, 85	PG-1754	13, 13A
		PG-1309	91	PG-1756	14
		PG-1310	91	PG-1763	43
		PG-1321	81	PG-1768	35
		PG-1338	5	PG-1769	35, 43
		PG-1342	54, 103	PG-1771	11
		PG-1346	97	PG-1772	63
		PG-1348	54, 77, 79	PG-1773	71
			97, 103	PG-1776	57B
				PG-1778	13, 13A
		PG-1362	64	PG-1785	61
		PG-1364	91	PG-1786	61
		PG-1365	91	PG-1787	61
		PG-1381	92	PG-1790	64
		PG-1386	61	PG-1791	15
		PG-1400	61, 100	PG-1794	49, 51
			106, 118	PG-1795	9
		PG-1417	64	PG-1799	63
		PG-1458	77, 79, 93	PG-1803	34
		PG-1576	11	PG-1804	19, 19B
		PG-1590	33	PG-1805	19, 19B
		PG-1607	33	PG-1808	85
		PG-1622	9, 49, 51	PG-1809	89
		PG-1633	7, 47	PG-1810	85
		PG-1636	33	PG-1811	85
		PG-1637	33	PG-1812	85
		PG-1649	11	PG-1815	77, 79
		PG-1655	60		109, 111
		PG-1661	42		17
		PG-1663	11, 53	PG-1825	17
		PG-1664	53	PG-1826	21
		PG-1667	42	PG-1827	40
		PG-1668	42	PG-1828	5
		PG-1670	42	PG-1831	100, 106
		PG-1673	60	PG-1832	118
		PG-1677	34		37
		PG-1678	34	PG-1864	30
		PG-1680	34	PG-1868	12
		PG-1681	31	PG-1892	

NUMERICAL INDEX

Part No.	Page	Part No.	Page	Part No.	Page
PG-1909	13A	PGF-3062	63	PGF-4383	89
PG-1910	15A	PGF-3075	7	PGF-4394	85
PG-1926	79	PGF-3079	7	PGF-4440	39
PG-1929	13A	PGF-3080	7	PGF-4442	39
		PGF-3081	7	PGF-4477	42, 85
		PGF-3082	7	PGF-4485	102
		PGF-3083	85	PGF-4488	103
PGA		PGF-3084	7, 47	PGF-4618	109
PGA-1314	81	PGF-3087	7, 47	PGF-4620	96
		PGF-3179	85	PGF-4667	7, 24, 25
		PGF-3184	9, 49, 51		26, 33, 47
		PGF-3186	9, 49, 51	PGF-4677	102
		PGF-3209	15, 15A	PGF-4702	47
PGF		PGF-3210	92	PGF-4742	107
PGF-268	5	PGF-3216	30	PGF-4759	59
PGF-309	34	PGF-3221	85	PGF-4770	102
PGF-597	63	PGF-3255	15, 15A	PGF-4852	7, 47
PGF-609	97, 103		77, 79	PGF-4864	7, 24, 25
			47		26, 33, 47
PGF-689	97	PGF-3261	54	PGF-4865	7, 33, 47
PGF-1031	85	PGF-3317	12, 54	PGF-4909	91
PGF-1068	5	PGF-3318	54	PGF-4916	89, 91, 92
PGF-1090-8	107	PGF-3504	75	PGF-4917	91
PGF-1157	14, 54, 103	PGF-3579	92	PGF-4918	91
PGF-1158	14, 54, 103	PGF-3609	92	PGF-4920	91
PGF-1458	105	PGF-3610	9, 49, 51	PGF-4921	91
PGF-1543	12, 17	PGF-3677	9, 49, 51	PGF-4922	91
PGF-1652	97, 103	PGF-3849	33	PGF-4926	81
		PGF-3850	34	PGF-4936	94
PGF-1685	103	PGF-3932	59	PGF-4937	94
PGF-1687	12, 14, 54	PGF-3955	11, 53	PGF-4941	81
		PGF-4043	63	PGF-4943	92
PGF-1688	15, 15A	PGF-4045	63	PGF-4946	96
		PGF-4057	71	PGF-4950	96
PGF-1699	54, 77, 79	PGF-4108	5	PGF-4952	95
		PGF-4111-6	5	PGF-4960	92
		PGF-4184	7, 47	PGF-4964	97
		PGF-4194	7	PGF-4996	9, 49, 51
PGF-1724	102	PGF-4217	33	PGF-5131	53
PGF-1727	15, 15A	PGF-4256	12	PGF-5160	73
PGF-1858	82	PGF-4258	12	PGF-5161	73
PGF-2075	101	PGF-4259	12	PGF-5162	73
PGF-2076	101	PGF-4260	12	PGF-5163	73
PGF-2077	58, 102	PGF-4261	12	PGF-5164	5
PGF-2096	57B	PGF-4288	7	PGF-5166	34
PGF-2264	57B	PGF-4339-2	9, 49, 51	PGF-5212	5
PGF-2265	57B	PGF-4340	49	PGF-5235	63
PGF-2314	19, 19B	PGF-4341	9, 49, 51	PGF-5240	7, 47
PGF-2354	57B	PGF-4345	9, 49, 51	PGF-5274	89
PGF-2360	99, 101	PGF-4346	9, 49, 51	PGF-5276	89
		PGF-4347	9, 49, 51	PGF-5277	89
PGF-2361	99, 101	PGF-4350	49	PGF-5284	96
		PGF-4358	9, 49, 51	PGF-5285	96
PGF-2418	57B	PGF-4360	9, 49, 51	PGF-5286	96
PGF-2840	89	PGF-4361	9, 49, 51	PGF-5287	89
PGF-3021	64	PGF-4362	9, 49, 51		
PGF-3047	12				
PGF-3048	12				
PGF-3060	59				

NUMERICAL INDEX

Part No.	Page	Part No.	Page	Part No.	Page
PGF-5288	89	PGF-5534	92	PGF-6804	81
PGF-5289	89	PGF-5558	91	PGF-6807	102
PGF-5297	96	PGF-5590	15, 15A	PGF-6808	102
PGF-5301-X	91		77, 79	PGF-6809	102
PGF-5304	89	PGF-5591	9, 49, 51	PGF-6810	92
PGF-5314	93	PGF-5613	81	PGF-6811	92
PGF-5315	93	PGF-5614	81	PGF-6817	82
PGF-5316	93	PGF-5615	81	PGF-6818	82
PGF-5317	93	PGF-5619	81	PGF-6820	102
PGF-5318	93	PGF-5620	81	PGF-6846	95
PGF-5319	93	PGF-5621	81	PGF-6932	63
PGF-5320	85	PGF-5627	85	PGF-6997	54, 77
PGF-5321	82	PGF-5630	85		79, 97
PGF-5324	85	PGF-5634	83		103, 117
PGF-5328	92	PGF-5637	83	PGF-7012	9, 49, 51
PGF-5330	85	PGF-5638	83	PGF-7019	12, 17, 54
PGF-5336	85	PGF-5641	92		77, 79, 97
PGF-5337	89	PGF-5652	64		103
PGF-5338	89	PGF-5691	63	PGF-7022	12, 17
PGF-5339	89	PGF-5692	63	PGF-7025	12, 17, 54
PGF-5340	89	PGF-5695	53		77, 79, 97
PGF-5342	97	PGF-5698	75		103
PGF-5343	89	PGF-5710	85, 87	PGF-7026	12, 17
PGF-5344	89	PGF-5717	30	PGF-7191	75
PGF-5345	89	PGF-5743	82	PGF-7193	91
PGF-5346	89	PGF-5756	71	PGF-7194	91
PGF-5347	82	PGF-5909	63	PGF-7216	91
PGF-5349	82	PGF-5930	57B	PGF-7328	57B
PGF-5350	94	PGF-5982	41	PGF-7355	91
PGF-5353	91	PGF-6024	33	PGF-7405	85
PGF-5354	91	PGF-6114	63	PGF-7413	39
PGF-5355	81	PGF-6462	41	PGF-7481	57A
PGF-5356	81	PGF-6505	68	PGF-7487	5
PGF-5375	75	PGF-6510	120	PGF-7524	19, 19B
PGF-5376	75	PGF-6539	81		57, 99
PGF-5380	91	PGF-6545	57B		105, 115
PGF-5405	75	PGF-6640	75	PGF-7590	35
PGF-5408	92	PGF-6641	77, 79	PGF-7610	35
PGF-5409	96	PGF-6717	91	PGF-7638	68
PGF-5410	89	PGF-6719	91	PGF-7646	37
PGF-5418	97	PGF-6720	91	PGF-7647	63
PGF-5421	85	PGF-6721	91	PGF-7691	64
PGF-5424	81	PGF-6726	91	PGF-7692	64
PGF-5433	9, 49, 51	PGF-6727	91	PGF-7693	64
PGF-5436	9, 49, 51	PGF-6759	81	PGF-7721	30, 34
PGF-5438	9, 49, 51	PGF-6779	91	PGF-7737	43
PGF-5439	9, 49, 51	PGF-6780	91	PGF-7817-900	57B
PGF-5464	81	PGF-6785	85, 90	PGF-7831	61
PGF-5465	82	PGF-6791	41	PGF-7832	61
PGF-5468	85	PGF-6794	81	PGF-7835	61
PGF-5474	81	PGF-6796	81	PGF-7836	61
PGF-5475	82	PGF-6797	81	PGF-7857	77, 79
PGF-5478	94	PGF-6798	81	PGF-7858	77, 79
PGF-5479	94	PGF-6799	81	PGF-7884	77, 79
PGF-5502	11, 53	PGF-6801	81	PGF-7938	17

NUMERICAL INDEX

Part No.	Page	Part No.	Page	Part No.	Page
PGF-8139	6C	PGF-8642	33	PGF-8837	33
PGF-8148	19,19B	PGF-8643	33	PGF-8839	42
PGF-8163	95	PGF-8644	33	PGF-8840	42
PGF-8164	95	PGF-8647	33	PGF-8851	34
PGF-8165	95	PGF-8686	7,47	PGF-8855	33
PGF-8226	12	PGF-8706	33	PGF-8857	35
PGF-8243	17	PGF-8708	33	PGF-8861	25
PGF-8248	17	PGF-8709	33	PGF-8862	42
PGF-8252	17	PGF-8714	7,47	PGF-8864	24
PGF-8325	17	PGF-8715	7,47	PGF-8865	25
PGF-8330	89	PGF-8728	17	PGF-8867	34
PGF-8390	75	PGF-8731	17	PGF-8882	34
PGF-8426	33	PGF-8738	11	PGF-8884	34
PGF-8428	33	PGF-8753	10,52,53	PGF-8885	34
PGF-8429	33	PGF-8757	10,51,53	PGF-8890	57A
PGF-8431	33	PGF-8760	42	PGF-8895	35
PGF-8433	30,33,85	PGF-8762	42	PGF-8896	17
PGF-8434	33	PGF-8763	42	PGF-8897	22,22A
PGF-8435	33	PGF-8764	85	PGF-8898	22,22A
PGF-8436	33	PGF-8766	42	PGF-8900	34
PGF-8437	33	PGF-8775	60,100	PGF-8902	17
PGF-8438	33		106,118	PGF-8903	17
PGF-8439	33	PGF-8776	19,57B	PGF-8908	17
PGF-8440-2	33	PGF-8776-2	19,19B	PGF-8909	17
PGF-8445	33		57B	PGF-8924	69
PGF-8446	31,33	PGF-8779	19,19B	PGF-8931	19,19B
PGF-8447	33	PGF-8780	60,100	PGF-8932	57A
PGF-8450	33		106,118	PGF-8933	57A
PGF-8458	65	PGF-8781	60,100	PGF-8938	17
PGF-8479	31		106,118	PGF-8940	37
PGF-8486	34	PGF-8784	60	PGF-8946	60,100
PGF-8489	34	PGF-8785	60,100		106,118
PGF-8498	33		106,118	PGF-8948	19,19B
PGF-8521	33	PGF-8804	9,49,51	PGF-8949	19,19B
PGF-8555	5	PGF-8805	33	PGF-8956	81
PGF-8557	5	PGF-8806	33	PGF-8960	61
PGF-8565	19,19B	PGF-8807	26	PGF-8961	61
PGF-8568	9,49,51	PGF-8809	33	PGF-8968	34,39
PGF-8583	47	PGF-8811	64	PGF-8968-55	39
PGF-8585	47	PGF-8814	33	PGF-8968-56	39
PGF-8586	7	PGF-8815	33	PGF-8970	35
PGF-8588	24,26	PGF-8816	34	PGF-8971	41
PGF-8595	7,47	PGF-8817	34	PGF-8972	35
PGF-8599	47	PGF-8818	34	PGF-8973	57A
PGF-8602	7	PGF-8819	33	PGF-8975	57A
PGF-8607	24	PGF-8821	33	PGF-8977	43
PGF-8609	7	PGF-8822	55	PGF-8978	42
PGF-8610	7	PGF-8823	12	PGF-8979	41
PGF-8611	7,9	PGF-8824	33	PGF-8981	71
PGF-8612	47,49,51	PGF-8825	33	PGF-8982	12
PGF-8630	7,47	PGF-8826	33	PGF-8983	12
PGF-8631	7,47	PGF-8827	33	PGF-8985	12
PGF-8632	7,47	PGF-8828	35	PGF-8986	12,17
PGF-8633	7,47	PGF-8831	42	PGF-8989	57B
PGF-8638	34	PGF-8835	11	PGF-8991	21

NUMERICAL INDEX

Part No.	Page	Part No.	Page	Part No.	Page
PGF-8992	43	PGF-9112	30	PGF-9253	17
PGF-8996	19,19B,21	PGF-9114	31	PGF-9259	34
PGF-9002	61	PGF-9115	31	PGF-9260	35,43
PGF-9009	61	PGF-9116	31	PGF-9263	11
PGF-9013	21	PGF-9117	31	PGF-9264	35
PGF-9014	31,34	PGF-9118	31	PGF-9269	42
PGF-9018	39,40	PGF-9119	31	PGF-9270	22,22A
PGF-9027	31	PGF-9120	31	PGF-9271	5
PGF-9029	7	PGF-9121	31	PGF-9273	54
PGF-9049	75	PGF-9122	30	PGF-9274	54
PGF-9053	64	PGF-9123	30	PGF-9275	71
PGF-9054	5	PGF-9125	30	PGF-9279	73
PGF-9062	31	PGF-9126	30	PGF-9280	71
PGF-9063	31	PGF-9127	30	PGF-9281	71
PGF-9064	31	PGF-9128	30	PGF-9282	73
PGF-9065	31	PGF-9129	30	PGF-9286	65
PGF-9066	30	PGF-9130	30	PGF-9297	40
PGF-9067	31	PGF-9131	30	PGF-9298	64
PGF-9068	31	PGF-9132	30	PGF-9299	64
PGF-9069	31	PGF-9133	30	PGF-9302	61
PGF-9070	31	PGF-9134	31	PGF-9305	13,13A
PGF-9071	31	PGF-9156	30	PGF-9306	13,13A
PGF-9072	31	PGF-9157	30	PGF-9316	63
PGF-9073	31	PGF-9158	31	PGF-9331	61
PGF-9074	31	PGF-9159	30	PGF-9336	65,71
PGF-9075	31	PGF-9160	30,34	PGF-9337	64
PGF-9076	31	PGF-9161	17	PGF-9338	71
PGF-9077	31	PGF-9220	13,13A	PGF-9339	68
PGF-9078	31	PGF-9221	13,13A,14	PGF-9341	73,83
PGF-9079	27,65	PGF-9222	13,13A	PGF-9342	73,81,83
PGF-9080	37	PGF-9223	13,13A	PGF-9343	73,83
PGF-9081	37	PGF-9224	13,13A	PGF-9344	107
PGF-9082	30	PGF-9225	13,13A	PGF-9346	107
PGF-9083	31		116	PGF-9347	107
PGF-9084	31	PGF-9226	13,13A	PGF-9349	73
PGF-9087	11	PGF-9227	13,13A	PGF-9350	73
PGF-9091	30	PGF-9228	13	PGF-9351	73
PGF-9092	37	PGF-9229	13,13A,14	PGF-9352	73
PGF-9094	37	PGF-9232	13,13A	PGF-9354	73
PGF-9095	37	PGF-9234	65	PGF-9355	73
PGF-9096	37	PGF-9235	13,13A	PGF-9356	73
PGF-9097	37	PGF-9236-3	19,19B	PGF-9357	73
PGF-9098	37	PGF-9237	14	PGF-9358	107,119
PGF-9099	37	PGF-9238	14	PGF-9359	73,74
PGF-9101	37	PGF-9239	14	PGF-9360	73,74
PGF-9102	30	PGF-9240	14	PGF-9361	34
PGF-9103	31,37	PGF-9241	14	PGF-9363	34
PGF-9104	37	PGF-9242	14	PGF-9364	34
PGF-9105	37	PGF-9243	14	PGF-9365	37
PGF-9106	31	PGF-9244	19,19B	PGF-9370	120
PGF-9107	31	PGF-9245	14	PGF-9371	120
PGF-9108	31	PGF-9246	14	PGF-9373	59
PGF-9109	31	PGF-9248	26	PGF-9374	57A
PGF-9110	31	PGF-9249	17	PGF-9377	9,49,51
PGF-9111	36	PGF-9250	17	PGF-9378	37

NUMERICAL INDEX

Part No.	Page	Part No.	Page	Part No.	Page
PGF-9380	63	PGF-9480	57B	PGF-9537-5	57B
PGF-9381	63	PGF-9481	57A	PGF-9538-4	99
PGF-9391	10, 53	PGF-9482	57A	PGF-9538-5	57B
PGF-9392	10, 52, 53	PGF-9483	21	PGF-9539-4	99, 105
PGF-9396	10, 52, 53	PGF-9485	21	PGF-9539-5	57B
PGF-9404	61	PGF-9486	7, 9, 47	PGF-9540	22
PGF-9405	61		49, 51	PGF-9541	22, 22A
PGF-9406	61	PGF-9487	12, 14, 15	PGF-9547	73
PGF-9407	61		15A, 19, 19B	PGF-9549	71
PGF-9413	57B		54, 75, 77	PGF-9556	77, 79
PGF-9414	57B		79, 109	PGF-9562	77, 109
PGF-9415	15		111, 116		111
PGF-9417	15	PGF-9488	64	PGF-9563	77
PGF-9418	15	PGF-9489	64	PGF-9564	77
PGF-9419	15	PGF-9490	71	PGF-9566	77, 109
PGF-9420	15, 15A	PGF-9491	71		111
PGF-9422	15, 15A	PGF-9496-3	99, 105, 115	PGF-9567	77, 79
PGF-9436	7, 47	PGF-9496-5	57	PGF-9586-1	5
PGF-9437	21	PGF-9496-7	57, 99	PGF-9588	10, 52, 53
PGF-9439	57B		105, 115	PGF-9589	22
PGF-9440	57A	PGF-9496-8	57, 99	PGF-9591	52
PGF-9441	57		105, 115	PGF-9610	34
PGF-9442	57	PGF-9497-3	99, 105	PGF-9616	19, 19B
PGF-9443	57A		115	PGF-9617	19, 19B
PGF-9444	57	PGF-9497-5	57	PGF-9618	19, 19B
PGF-9445	57	PGF-9497-7	57, 99	PGF-9619	17
PGF-9446	57		105, 115	PGF-9620	19, 19B
PGF-9449	57	PGF-9497-8	57, 99	PGF-9627	75
PGF-9450	57		105, 115	PGF-9628	57B
PGF-9453	54	PGF-9498	73	PGF-9629	42
PGF-9454	57	PGF-9499	73	PGF-9630	92
PGF-9455	57	PGF-9506	73	PGF-9631	45
PGF-9456	57	PGF-9508	73	PGF-9632	5
PGF-9458	57	PGF-9512	5	PGF-9633	5
PGF-9459	57	PGF-9518	73	PGF-9634	5
PGF-9460	57	PGF-9520	57A	PGF-9635	5
PGF-9461	57	PGF-9521	14	PGF-9636	5
PGF-9462	57	PGF-9522	57A	PGF-9637	5
PGF-9463	57	PGF-9523	57A	PGF-9642-1	5
PGF-9464	57A	PGF-9524	57A	PGF-9642-2	5
PGF-9465	57A	PGF-9525	57A	PGF-9642-5	5
PGF-9466	57A	PGF-9526	57B	PGF-9645	5
PGF-9467	57A	PGF-9527	57B	PGF-9646	5
PGF-9468	57	PGF-9529	57	PGF-9647	17
PGF-9469	57	PGF-9530	13, 13A	PGF-9648-1	17, 116
PGF-9470	57A	PGF-9531	57	PGF-9648-2	15, 15A
PGF-9471	57A	PGF-9532	57		57B
PGF-9472	57A	PGF-9533	57	PGF-9648-6	57B
PGF-9473	57A	PGF-9534-2	57A	PGF-9648-9	116
PGF-9474	57A	PGF-9534-9	57B	PGF-9648-10	117
PGF-9475	57A	PGF-9534-10	57B	PGF-9648-11	116
PGF-9476	57	PGF-9535-6	57B	PGF-9648-12	117
PGF-9477	57A	PGF-9536-6	57B	PGF-9648-13	117
PGF-9478	57	PGF-9537-4	57, 99	PGF-9648-21	17
PGF-9479	57		105, 115	PGF-9648-22	17

NUMERICAL INDEX

Part No.	Page	Part No.	Page	Part No.	Page
PGF-9648-24	13A	PGF-9768	82	PGF-9917	63
PGF-9649	17	PGF-9769	17	PGF-9918	64
PGF-9650	81	PGF-9772	43	PGF-9919	63
PGF-9651	81	PGF-9775	82	PGF-9920	63
PGF-9656	77, 109	PGF-9778	99, 115	PGF-9930	99
	111	PGF-9779	5	PGF-9931	63
PGF-9657	85	PGF-9779-2	5	PGF-9932	63
PGF-9658	85	PGF-9779-3	5	PGF-9933	64
PGF-9659	85	PGF-9780	5	PGF-9934	64
PGF-9960	85	PGF-9781	5	PGF-9938	5
PGF-9661	85	PGF-9782	5	PGF-9939	12
PGF-9662	85	PGF-9788	99, 105	PGF-9940	5
PGF-9663	85	PGF-9790	75	PGF-9941	5
PGF-9665	82	PGF-9791	99, 105	PGF-9942	5
PGF-9666	82		115	PGF-9943	63
PGF-9667	81	PGF-9792	77	PGF-9944	12
PGF-9668	82	PGF-9793	82	PGF-9945	58
PGF-9669	81	PGF-9794	81	PGF-9946	58
PGF-9670	82	PGF-9795	83	PGF-9953	63
PGF-9671	81	PGF-9796	73	PGF-9955	73
PGF-9672	81	PGF-9797	74	PGF-9960	69
PGF-9673	81	PGF-9798	73	PGF-9961	74
PGF-9674	82	PGF-9799	74	PGF-9962	37
PGF-9675	81	PGF-9802	99, 105	PGF-9963	73
PGF-9676	81		115	PGF-9964	85
PGF-9677	82	PGF-9803	99, 105	PGF-9965	73
PGF-9678	81	PGF-9806	99, 105	PGF-9966	73, 83
PGF-9679	81	PGF-9807	115		107
PGF-9680	81	PGF-9808	99, 105	PGF-9970	57
PGF-9682	81		115	PGF-10006	107
PGF-9684	102	FGF-9809	115	PGF-10026	73
PGF-9687	102	PGF-9812-8	57A	PGF-10027	73
PGF-9688	102	PGF-9822	82, 100	PGF-10028	73
PGF-9689	77	PGF-9823	90	PGF-10034	73
PGF-9690	77	PGF-9825	57A	PGF-10037	34
PGF-9692	77, 109	PGF-9831	34	PGF-10039	107
	111	PGF-9858	5	PGF-10045	73
PGF-9693	75, 77	PGF-9864	31, 35	PGF-10047	73
	109, 111	PGF-9865-4	115	PGF-10057	21
PGF-9694	75	FGF-9875	120	PGF-10059	30
PGF-9695	75	PGF-9885	37	PGF-10080	73
PGF-9696	77, 109	PGF-9886	71	PGF-10084	15A
	111	PGF-9888	34	PGF-10085	73
PGF-9738	30, 34, 42	PGF-9889	34	PGF-10086	92
PGF-9748	19	PGF-9890	63	PGF-10104-4	57
PGF-9750	57B	PGF-9897	63	PGF-10108	81
PGF-9751	57B	PGF-9899	64	PGF-10111	64
PGF-9752	19, 19B	PGF-9900	63	PGF-10112	71
PGF-9757	64	PGF-9901	64	PGF-10113	69
PGF-9759	99, 105	PGF-9902	63	PGF-10114	64, 69
PGF-9761	17	PGF-9906	64	PGF-10115	73
PGF-9762	17	PGF-9908	64	PGF-10117	73
PGF-9765	100, 106	PGF-9909	64	PGF-10118	73
PGF-9766	21, 40	PGF-9912	66	PGF-10119	73
PGF-9767	40	PGF-9915	63	PGF-10121	64

NUMERICAL INDEX

Part No.	Page	Part No.	Page	Part No.	Page
PGF-10122	73	PGF-10211	22	PGF-10496	19,19B
PGF-10123	73	PGF-10212	22	PGF-10498	15A
PGF-10124	64	PGF-10213	15	PGF-10499	15A
PGF-10125	64	PGF-10214	37	PGF-10500	15A
PGF-10129	69	PGF-10215	22	PGF-10501	15A
PGF-10130	64	PGF-10216	5	PGF-10502	19,19B
PGF-10131	69	PGF-10231	14,19,19B		57B
PGF-10132	69	PGF-10232	22,22A	PGF-10503	57B
PGF-10133	57	PGF-10233	22,22A	PGF-10504	19B
PGF-10135	73,74	PGF-10234	65	PGF-10505	22A
PGF-10136	73	PGF-10247	63	PGF-10517	57A
PGF-10140	25	PGF-10248	68	PGF-10518	57B
PGF-10141	25	PGF-10248-2	68	PGF-10519	21
PGF-10143-3	99,105	PGF-10252	68	PGF-10530	92
	115	PGF-10309	64	PGF-10531	57B
PGF-10143-5	57A	PGF-10314	12	PGF-10532	57
PGF-10143-7	57	PGF-10324	74	PGF-10534	5
PGF-10143-8	99,105	PGF-10330	71	PGF-10543	5
	115	PGF-10332	71	PGF-10550	15A
PGF-10144-3	99,105	PGF-10333	71	PGF-10551	15A
PGF-10144-7	99,105	PGF-10334	71	PGF-10556	5
	115	PGF-10335	71	PGF-10566-7	57A
PGF-10144	57A,99	PGF-10348	5	PGF-10599	22A
	105,115	PGF-10350	5	PGF-10600	22A
PGF-1045-7	57B	PGF-10356	5	PGF-10601	23,23A
PGF-10146-3	115	PGF-10358	19,19B	PGF-10602	23,23A
PGF-10147-3	99,105	PGF-10360	17	PGF-10603	22,22A
	115	PGF-10361	68	PGF-10606	63
PGF-10148	120	PGF-10362	68	PGF-10607	19,19B
PGF-10149	120	PGF-10363	68	PGF-10628	74
PGF-10150	120	PGF-10365	17	PGF-10629	74
PGF-10155	115	PGF-10368	64	PGF-10632	74
PGF-10161-8	99,105	PGF-10369	5	PGF-10644	77,79,109
	115	PGF-10370	5	PGF-10700	73
PGF-10162	115	PGF-10377	64	PGF-10707	22
PGF-10170	64	PGF-10379	83	PGF-10712	75,79
PGF-10181	67	PGF-10380	83		109,111
PGF-10188	30,37	PGF-10381	83	PGF-10720	79,109
PGF-10140	25	PGF-10383	83		111
PGF-10141	25	PGF-10385	83	PGF-10721	79
PGF-10142	5	PGF-10389	17	PGF-10726	79
PGF-10189	30	PGF-10390	107	PGF-10727	73,83
PGF-10195	67	PGF-10396	107	PGF-10730	79,109
PGF-10196	67	PGF-10421	73,83		111
PGF-10197	67	PGF-10474	19	PGF-10731	79,109
PGF-10198	67	PGF-10485	13,13A		111
PGF-10199	67	PGF-10486	13A	PGF-10732	79,109
PGF-10200	67	PGF-10487	13A		111
PGF-10201	47	PGF-10488	13A	PGF-10733	79
PGF-10202	45B	PGF-10489	13A	PGF-10734	79,109
PGF-10205	23	PGF-10490	57		111
PGF-10207	23,23A	PGF-10491	57	PGF-10736	79,109
PGF-10208	23,23A	PGF-10492	71		111
PGF-10209	23,23A	PGF-10493	57	PGF-10746	73
PGF-10210	23,23A	PGF-10495	19,19B	PGF-10747	73

NUMERICAL INDEX

Part No.	Page	Part No.	Page	Part No.	Page
PGF-10749	83	PGU-1809	77	PGX-1691	103
PGF-10753	37	PGU-1810	77	PGX-2261	57B
PGF-10771	99	PGU-1810-A	79	PGX-8777	77
PGF-10772	105	PGU-1820	92	PGX-9749	22
PGF-10773	105	PGU-1822	30	PGX-10433	22A
PGF-10776	68	PGU-1823-A	30	PGX-10699	79
PGF-10777	68	PGU-1842-B	12		
PGF-10794	22	PGU-1845	7		
PGF-10804	14, 54, 103	PGU-1851	47	P S F	
PGF-10805	12	PGU-1857-A	36	PSF-1481	21
PGF-10807	12	PGU-1863	15	PSF-2264	57B
PGF-10819	22, 22A	PGU-1873	57B		
		PGU-1905-A	14		
P G P		PGU-1906-A	14	R D	
PGP-1813	57B	PGU-1907	13	RD-CL-1011	87
PGP-1873	47	PGU-1907-B	13A	RD-CL-1011-2	45, 45B
PGP-9974	34	PGU-1915	22	RD-CL-1608	87
		PGU-1915-A	22	RD-CL-2326	87
P G U		PGU-1917	23	RD-CL-3089	87
PGU-1433-A	97	PGU-1917-A	23A	RD-CL-3302	87
PGU-1439	94	PGU-1918	23	RD-CL-3353	87
PGU-1455	94	PGU-1918-A	23A	RD-CL-3400-1	87
PGU-1456	93	PGU-1919	23	RD-CL-3401	87
PGU-1457	93	PGU-1919-A	23A	RD-CL-3478	87
PGU-1459	94	PGU-1920	23	RD-CL-3745	87
PGU-1462	92	PGU-1920-A	23A	RD-CL-3747-1	87
PGU-1464	94	PGU-1921	23	RD-CL-3921	87
PGU-1467	96	PGU-1921-A	23A	RD-CL-4136	87
PGU-1469	81	PGU-1922	23	RD-CL-4347	87
PGU-1576-A	95	PGU-1922-A	23A	RD-CL-4586	87
PGU-1577	91	PGU-1923	15	RD-CL-4597	45, 87
PGU-1652	47	PGU-1924	68	RD-CL-4799	87
PGU-1655	7	PGU-1935-A	15A	RD-CL-5215	87
PGU-1656	7	PGU-1937-A	22A	RD-CL-5248	87
PGU-1657	47	PGU-1938-A	22A	RD-CL-6280	45, 45B
PGU-1658	7	PGU-1949	79	RD-CL-6283	45, 45B
PGU-1668	17	PGU-5437	9, 49, 51	RD-CL-6284	45, 45B
PGU-1669	17	PGU-6806	102	RD-CL-6615-6	45, 45B
PGU-1670	17, 19, 19B			RD-CL-6664	45, 45B
PGU-1676-A	54	P G U S		RD-CL-6824	45, 45B
PGU-1682-A	17	PGUS-9161	59	RD-CL-6825	45
PGU-1683-A	17	PGUS-9206	12	RD-CL-6825-1	45B
PGU-1694	14	PGUS-9207	17	RD-CL-7079	45, 45B
PGU-1695	10, 53	PGUS-9208	17	RD-CL-7080	45, 45B
PGU-1714	52	PGUS-9209	60	RD-CL-7563	45, 45B
PGU-1715	22	PGUS-9210	67	RD-CL-7575	45B
PGU-1715-A	22	PGUS-9211	67	RD-CL-7888	45B
PGU-1738-A	30	PGUS-9212	92	RD-UCL-24-862	87
PGU-1741-A	34			RD-UCL-3478-S4	87
PGU-1800	100, 106	P G X		RD-UCL-3744	87
	118	PGX-990	7	RD-UCL-4-4541	45, 45B
PGU-1803-A	103	PGX-1353	47	RD-UCL-4600-S2A	87
PGU-1804-A	103	PGX-1414	35	RD-UCL-4601	87
				RD-UCL-1-4601-A	87
				RD-UCL-4824-1	87