

(USED ON TRACTORS PRIOR TO M-4142 ONLY)

PLATE 1772—FINAL DRIVE (FIRST TYPE)

**FINAL DRIVE**  
(See Plate 1772)

USAGE: Tractors prior to serial No. 4142 only. Also see page 89 for special parts used only on 50" tread Model.

ITEM	PART NUMBER	QUANTITY		DESCRIPTION	PACKAGE OR KIT NUMBER
		*	**		
1	045052	2	-	CASE, gear - inner half	
2	035236	24	-	CAPSCREW, hex-hd., 1/2"NC x 1-3/4"	
	904208	24	-	LOCKWASHER, 1/2"	
3	AM-8801	10	-	CAPSCREW, hex-hd., 1/2"NC x 2"	
	904208	10	-	LOCKWASHER, 1/2"	
4	045032	2	2	GASKET, final drive to transmission case	
5	046439	2	2	TROUGH, oil (Used on tractors after #895)	
6	013044	4	4	CAPSCREW (drilled hex-hd., 3/8"NC x 7/8"	
	023633	2	2	WIRE, locking (1/16" x 12")	
7	035250	4	4	PLUG, oil filler and drain	
8	035249	4	4	GASKET, oil filler and drain plug	
9	901653	2	2	PLUG, pipe, square head, 3/8"NPT (oil level)	
10	045051	2	2	CASE, gear - outer half (Used on tractors prior to #2942)	
	030570	2	2	CASE, gear - outer half (Used on tractors after #2941)	
11	013058	8	8	CAPSCREW, hex-hd., 3/8"NC x 1-1/4"	
	904206	8	8	LOCKWASHER, 3/8"	
12	U-3188	12	-	CAPSCREW, hex-hd., 3/8"NF x 1-1/2"	
	046419	-	14	CAPSCREW, hex-hd., 3/8"NF x 2"	
	035336	14	12	CAPSCREW, hex-hd., 3/8"NF x 1-3/4"	
	911041	26	26	NUT, hex, 3/8"NF	
13	904206	26	26	LOCKWASHER, 3/8"	
	013058	4	-	CAPSCREW, hex head, 3/8"NC x 1-1/4"	
	035336	-	4	CAPSCREW, hex-hd., 3/8"NF x 1-3/4"	
	911041	-	4	NUT, hex, 3/8"NF	
14	045031	2	2	GASKET, gear case	
15	046361	2	2	GUARD, sprocket - lower (Used on tractors after #746)	
16	045025	2	2	DRUM, brake	
17	045050	2	2	NUT	
18	045379	2	2	LOCKWASHER	
19	035705	2	2	KEY, brake drum	
NOTE: Items 20 thru 34 were used only on tractors prior to serial No. 2942.					
20	045024	2	-	PINION (12 teeth, 8-3/8" long)	
21	046446	2	2	DEFLECTOR, oil, pinion inner bearing	
22	042863	4	4	CONE ASSEMBLY, pinion roller bearing	
23	042862	4	4	CUP, pinion roller bearing	
24	045043	2	2	PIN, end washer locking	
25	045446	4	4	SHIM, adjusting, pinion bearing (.005" thick. Use as required)	
	045445	30	30	SHIM, adjusting, pinion bearing (.010" thick. Use as required)	
26	045042	2	2	WASHER, retaining, pinion outer bearing	
27	045036	2	2	BOLT (thin hex-hd., 7/8"NF x 1-1/2")	
28	045040	2	2	LOCKWASHER	
29	045092	2	2	CAGE, pinion inner bearing (Not used on 50" tread Model after tractor #237)	
	035244	-	8	CAPSCREW, hex-hd., 3/8"NC x 3/4"	
	904206	-	8	LOCKWASHER, 3/8"	
30	045026	2	2	CAGE, oil return (When replaced on tractors prior to #896 also order item 21 and discard item 32)	
31	028271	8	8	CAPSCREW, hex-hd., 3/8"NC x 1-3/4"	
	904206	8	8	LOCKWASHER, 3/8"	
32	045474	2	2	SEAL, cork, oil return cage (Used only on tractors prior to #896)	

(Continued)



FINAL DRIVE (Continued)  
(See Plate 1772)

ITEM	PART NUMBER	QUANTITY		DESCRIPTION	PACKAGE OR KIT NUMBER
		*	**		
33	045477	2	2	COVER, pinion outer bearing	
34	035439	8	8	CAPSCREW, hex-hd., 3/8"NC x 1"	
	904206	8	8	LOCKWASHER, 3/8"	
NOTE: Items 35 thru 42 were used only on tractors after serial No. 2941.					
35	030826	2	-	PINION (12 teeth, 8-3/8" long)	
36	030563	2	2	DEFLECTOR, oil, pinion inner bearing	
37	042835	4	4	BEARING, ball, drive pinion	
38	030564	4	4	BAFFLE, oil, pinion bearings	
39	030130	2	-	CAGE, pinion inner bearing	
40	013058	8	-	CAPSCREW, hex-hd., 3/8"NC x 1-1/4"	
	904206	8	-	LOCKWASHER, 3/8"	
41	030263	2	2	COVER, pinion outer bearing	
42	035439	8	8	CAPSCREW, hex-hd., 3/8"NC x 1"	
	904206	8	8	LOCKWASHER, 3/8"	
43	045030	4	4	GASKET, bearing cover	
44	045046	2	2	GASKET, pinion inner bearing cage (4 used on 40" tread tractors prior to #2942)	
45	045476	2	2	GEAR AND SHAFT (58 teeth)	
46	042884	2	2	CONE ASSEMBLY, gear shaft inner bearing	
47	U-2584	2	2	CUP, gear shaft inner bearing	
48	045044	2	2	WASHER, retaining, gear shaft inner bearing	
49	045034	2	2	NUT (hex, slotted, 1-1/4" thread)	
50	910148	2	2	PIN, cotter, 7/32" x 2"	
51	045028	2	2	COVER, gear shaft inner bearing (Not used on 50" tread tractors prior to #238)	
52	013044	8	8	CAPSCREW (drilled hex-hd., 3/8"NC x 7/8")	
	023633	4	4	WIRE, locking (1/16" x 12")	
53	042874	2	2	CONE ASSEMBLY, gear shaft outer bearing	
54	042898	2	2	CUP, gear shaft outer bearing	
55	045033	2	2	SPACER, sprocket packing	
56	045047	6	6	PACKING, track sprocket - outer (See NOTE below)	
57	045048	4	4	PACKING, track sprocket - inner (See NOTE below)	
58	045023	2	2	PLATE, pressure, track sprocket packing	
59	901288	6	6	SETSCREW, square head, cup point, 1/2"NC x 2"	
	911028	6	6	NUT, hex, 1/2"NC	
60	045045	2	2	PLATE, packing retaining	
61	070192	6	6	CAPSCREW, flat head, 3/8"NC x 1-1/8"	
62	045021	2	2	RETAINER, sprocket packing	
63	045022	2	2	GUARD, dirt, track sprocket packing	
	U-3188	10	10	CAPSCREW, hex-hd., 3/8"NC x 1-1/2"	} Tractors prior to #26
	904206	10	10	LOCKWASHER, 3/8"	
64	045575	2	2	RING, dirt guard stiffening (Tractors after #25)	
65	036039	10	10	CAPSCREW, hex-hd., 3/8"NF x 1-3/8"	
	904206	10	10	LOCKWASHER, 3/8"	
66	045020	2	2	SPROCKET, track	
67	036589	2	2	NUT (hex, 1-3/4" thread)	
68	045041	2	2	LOCKWASHER	
69	045038	2	2	KEY, track sprocket (5/8" x 5/8" x 4-3/8")	
70	045581	2	2	STOP, oil, track sprocket keyway (felt)	
71	910260	2	2	FITTING, lubricating, straight, 1/8"NPT (Used on tractors after #896)	

NOTE: An improved type Seal Arrangement has been made available for installation on tractors on which the packing type seal has proven unsatisfactory. Order CHANGEOVER KIT 033144 which provides sufficient material for one tractor. Also see Service Bulletin S-105.

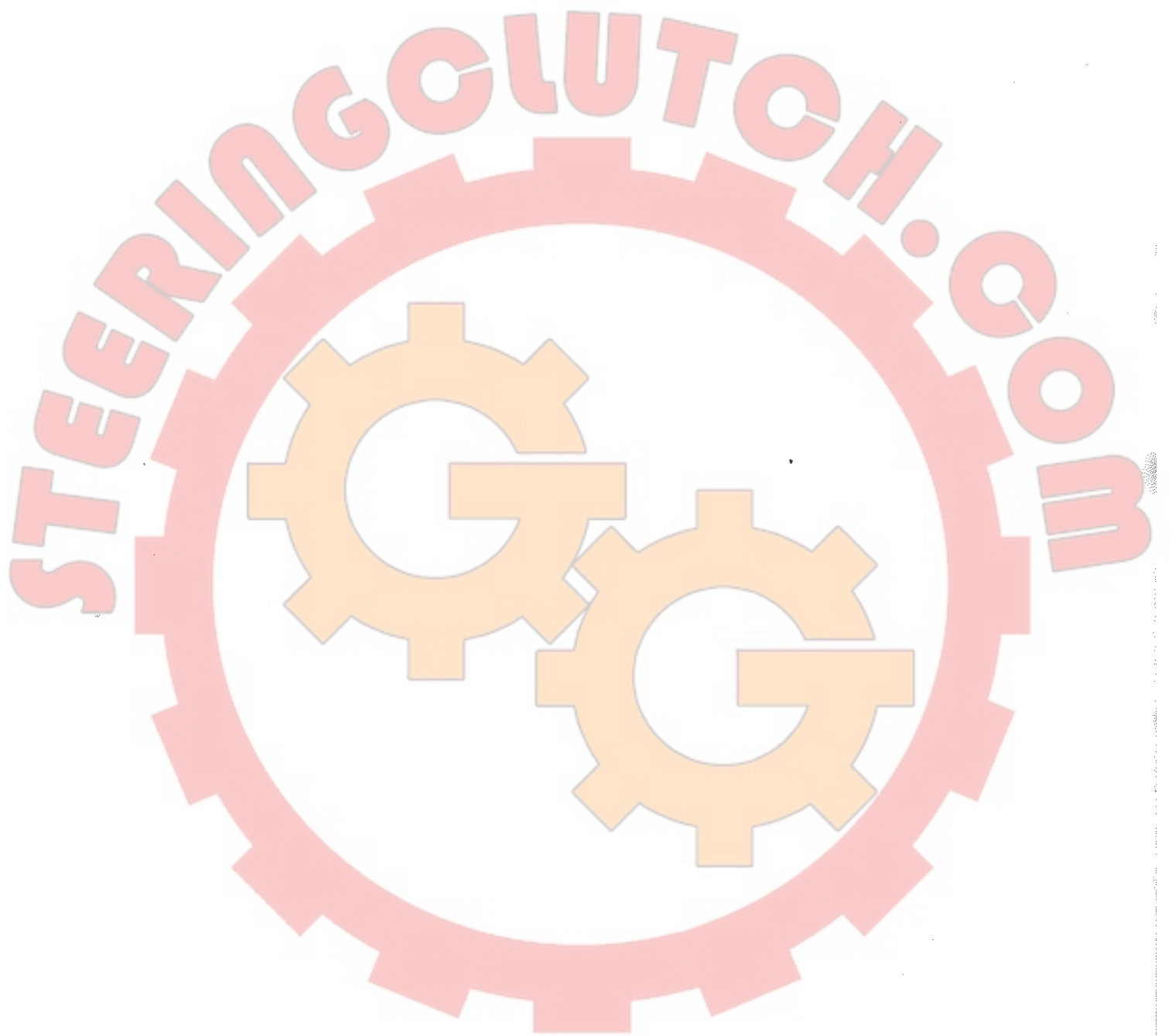

75401 19-1531

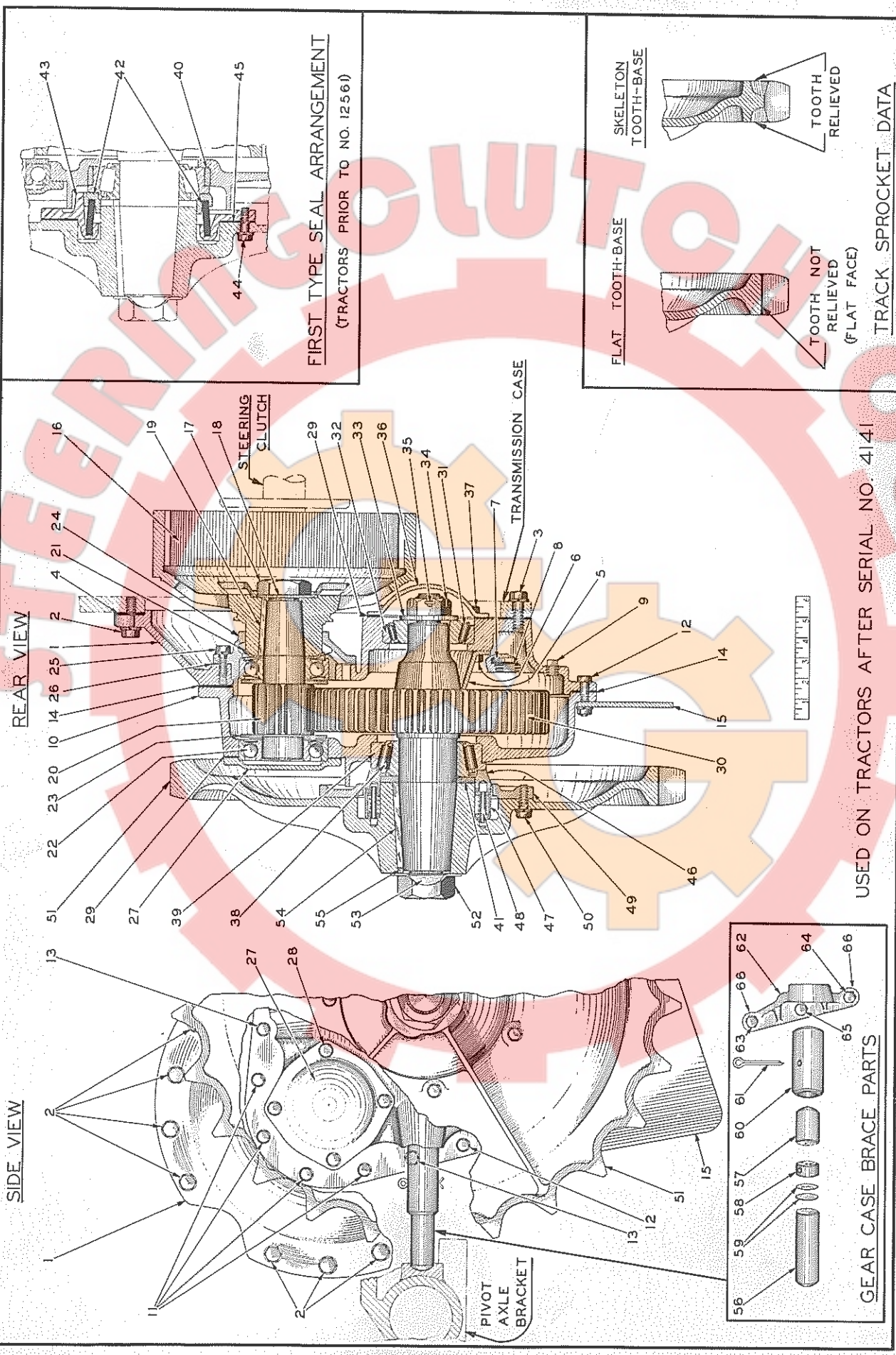

REAR VIEW

SIDE VIEW

FIRST TYPE SEAL ARRANGEMENT  
(TRACTORS PRIOR TO NO. 12561)

FLAT TOOTH-BASE

SKELETON TOOTH-BASE

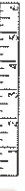

USED ON TRACTORS AFTER SERIAL NO. 4141

TRACK SPROCKET DATA

GEAR CASE BRACE PARTS

PLATE 1774 — FINAL DRIVE (SECOND TYPE)



FINAL DRIVE  
(See Plate 1774)

USAGE: Tractors after serial No. 4141. Also see page 89 for special parts used only on 50" tread model.

ITEM	PART NUMBER	QUANTITY		DESCRIPTION	PACKAGE OR KIT NUMBER
		*	**		
1	045052	2	-	CASE, gear - inner half	
2	035236	24	-	CAPSCREW, hex-hd., 1/2"NC x 1-3/4"	
	904208	24	-	LOCKWASHER, 1/2"	
3	AM-8801	10	-	CAPSCREW, hex-hd., 1/2"NC x 2"	
	904208	10	-	LOCKWASHER, 1/2"	
4	045032	2	2	GASKET, final drive to transmission case	
5	046439	2	2	TROUGH, oil	
6	013044	4	4	CAPSCREW (drilled, hex-hd., 3/8"NC x 7/8"	
	023633	2	2	WIRE, locking (1/16" x 12")	
7	035250	4	4	PLUG, oil filler and drain	
8	035249	4	4	GASKET, oil filler and drain plug	
9	901653	2	2	PLUG, pipe, square head, 3/8"NPT (oil level)	
10	032121	2	2	CASE, gear - outer half	
11	013058	8	8	CAPSCREW, hex head, 3/8"NC x 1-1/4"	
	904206	8	8	LOCKWASHER, 3/8"	
12	U-3188	12	-	CAPSCREW, hex head, 3/8"NF x 1-1/2"	
	046419	-	14	CAPSCREW, hex-hd., 3/8"NF x 2"	
	035336	14	12	CAPSCREW, hex-hd., 3/8"NF x 1-3/4"	
13	911041	26	26	NUT, hex, 3/8"NF	
	904206	26	26	LOCKWASHER, 3/8"	
	013058	4	-	CAPSCREW, hex-hd., 3/8"NC x 1-1/4"	
	035336	-	4	CAPSCREW, hex-hd., 3/8"NF x 1-3/4"	
14	911041	-	4	NUT, hex, 3/8"NF	
	904206	4	4	LOCKWASHER, 3/8"	
14	045031	2	2	GASKET, gear case	
15	046361	2	2	GUARD, sprocket - lower	
16	045025	2	2	DRUM, brake	
17	045050	2	2	NUT	
18	045379	2	2	LOCKWASHER	
19	035705	2	2	KEY, brake drum	
20	030826	2	-	PINION (12 teeth, 8-3/8" long)	
21	030563	2	2	DEFLECTOR, oil, pinion inner bearing	
22	042835	4	4	BEARING, ball, drive pinion	
23	030564	4	4	BAFFLE, oil, pinion bearings	
24	030130	2	-	CAGE, pinion inner bearing	
25	013058	8	-	CAPSCREW, hex-hd., 3/8"NC x 1-1/4"	
	904206	8	-	LOCKWASHER, 3/8"	
26	045046	2	-	GASKET, pinion inner bearing cage	
27	030263	2	2	COVER, pinion outer bearing	
28	035439	8	8	CAPSCREW, hex-hd., 3/8"NC x 1"	
	904206	8	8	LOCKWASHER, 3/8"	
29	045030	4	4	GASKET, bearing cover	
30	045476	2	2	GEAR AND SHAFT (58 teeth)	
31	042884	2	2	CONE ASSEMBLY, gear shaft inner bearing	
32	U-2584	2	2	CUP, gear shaft inner bearing	
33	045044	2	2	WASHER, retaining, gear shaft inner bearing	
34	045034	2	2	NUT (hex, slotted, 1-1/4" thread)	
35	910148	2	2	PIN, cotter, 7/32" x 2"	
36	045028	2	2	COVER, gear shaft inner bearing	
37	013044	8	8	CAPSCREW (drilled hex-hd., 3/8"NC x 7/8"	
	023633	4	4	WIRE, locking (1/16" x 12") (Used prior to #12561)	
	904206	8	8	LOCKWASHER, 3/8" (Used after #12560)	

FINAL DRIVE (Continued)  
(See Plate 1774)

ITEM	PART NUMBER	QUANTITY		DESCRIPTION	PACKAGE OR KIT NUMBER
		*	**		
				* 40" tread Model	
				** 50" tread Model	
38	042874	2	2	CONE ASSEMBLY, gear shaft outer bearing.....	033144
39	043635	2	2	CUP, gear shaft outer bearing.....	033144
40	031781	2	2	SPACER, gear shaft outer bearing (Used on tractors prior to approx. #5342).....	033144
41	032006	2	2	PLATE, spacing, gear shaft outer bearing.....	033144
				NOTE: Items 42 thru 45 comprise the FIRST TYPE SEAL and were used on tractors prior to #12561 only	
42	043448	2	2	SEAL ASSEMBLY (1 RING and 1 BOOT) (Also see item 67).....	033144
43	031782	2	2	RETAINER, gear shaft seal.....	033144
44	013058	10	10	CAPSCREW, hex-hd., 3/8"NC x 1-1/4".....	033144
	904206	10	10	LOCKWASHER, 3/8"	
45	031777	2	2	GASKET, gear shaft seal retainer.....	033144
				NOTE: Items 46 thru 50 comprise the SECOND TYPE SEAL and were used only on tractors after #12560. Can also be installed on tractors #4142 thru #12560 by replacing track SPROCKET 034876 with SPROCKET 044871 or 044261.	
46	044545	2	2	RING, gear shaft seal	
47	043282	2	2	BOOT, gear shaft seal	
48	044544	2	2	DRIVE ASSEMBLY, gear shaft seal (1-PLATE, 1 WASHER, 6 PINS, 6 SPRINGS. Serviced only as a unit)	
49	044546	2	2	GUARD, gear shaft seal	
50	013058	10	10	CAPSCREW, hex-hd., 3/8"NC x 1-1/4"	
	904206	10	10	LOCKWASHER, 3/8"	
51	034876	2	2	SPROCKET, track (Skeleton tooth-base)(Used on tractors prior to #12561 only)	
	044871	2	2	SPROCKET, track (Skeleton tooth-base) (Service replacement for SPROCKET 034876. Can be used with SECOND TYPE SEAL)	
	044261	2	2	SPROCKET, track (Flat tooth-base) (Service replacement for SPROCKET 034876. Can be used with SECOND TYPE SEAL)	
	044155	2	2	SPROCKET, track (Standard. Flat tooth-base) (Used on tractors after #12560)	
	044156	2	2	SPROCKET, track (Special. Skeleton tooth-base) (For tractors after #12560 only)	
52	036589	2	2	NUT (hex, 1-3/4" thread)	
53	045041	2	2	LOCKWASHER	
54	032374	2	2	KEY, track sprocket (5/8" x 5/8" x 4-1/8")	
55	045581	2	2	STOP, oil, track sprocket keyway	
				NOTE: Items 56 thru 66 were used only on tractors after #11572 altho these parts can be installed on prior machines also. See BRACE KIT 043551 and Service Bulletin 8-258.	
56	043500	2	2	PIN, gear case bracing - front.....	043551
57	043499	2	2	PIN, gear case bracing - rear.....	043551
58	043501	2	2	SPACER, gear case bracing pins.....	043551
59	043622	2	2	SHIM, gear case bracing pins (1/16" thick. Use as required).....	043551
	043502	20	20	SHIM, gear case bracing pins (.010" thick. Use as required).....	
60	043503	2	2	SLEEVE, gear case bracing pins.....	043551
61	901344	2	2	PIN, cotter, 1/4" x 2".....	043551
				NOTE: Items 62 thru 66 were used only on tractors #11573 thru approx. #11905.	
62	043541	1	1	SOCKET, gear case rear bracing pin - left.....	043551
	043542	1	1	SOCKET, gear case rear bracing pin - right.....	
63	028271	2	2	CAPSCREW, hex-hd., 3/8"NC x 1-3/4".....	043551
	904206	2	2	LOCKWASHER, 3/8"	
64	046419	2	-	CAPSCREW, hex-hd., 3/8"NF x 2".....	043551
	045174	-	2	CAPSCREW, hex-hd., 3/8"NF x 2-1/2".....	
	904206	2	2	LOCKWASHER, 3/8"	
	911041	-	2	NUT, hex, 3/8"NF	

(continued)

FINAL DRIVE (Continued)  
(See Plate 1774)

ITEM	PART NUMBER	QUANTITY		DESCRIPTION	PACKAGE OR KIT NUMBER
		*	**		
				* 40" Tread Model	
				** 50" Tread Model	
65	028271	2	-	CAPSCREW, hex-hd., 3/8"NC x 1-3/4".....	043551
	045174	-	2	CAPSCREW, hex-hd., 3/8"NF x 2-1/2".....	043551
	904206	2	2	LOCKWASHER, 3/8"	
	911041	-	2	NUT, hex, 3/8"NF	
66	043585	6	6	WASHER, spacing, rear bracing pin socket.....	043551
67	033288	-	-	CEMENT, neoprene (1/2 pint can) } Used to cement	
68	054890	-	-	SOLVENT, neoprene cement (1/2 pint can) } seal boots	

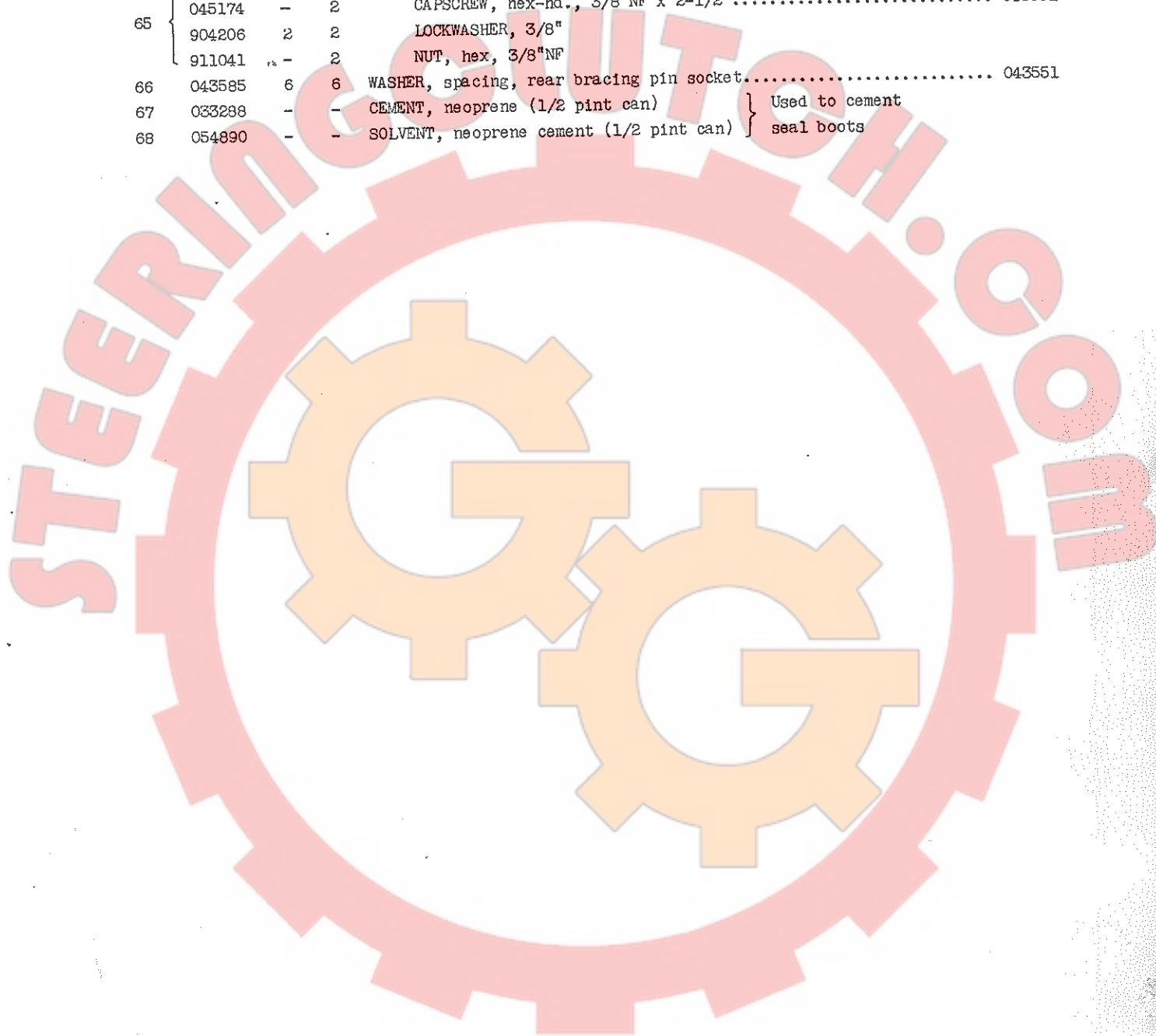



TRANSMISSION CASE

10 8 3 5 2 6

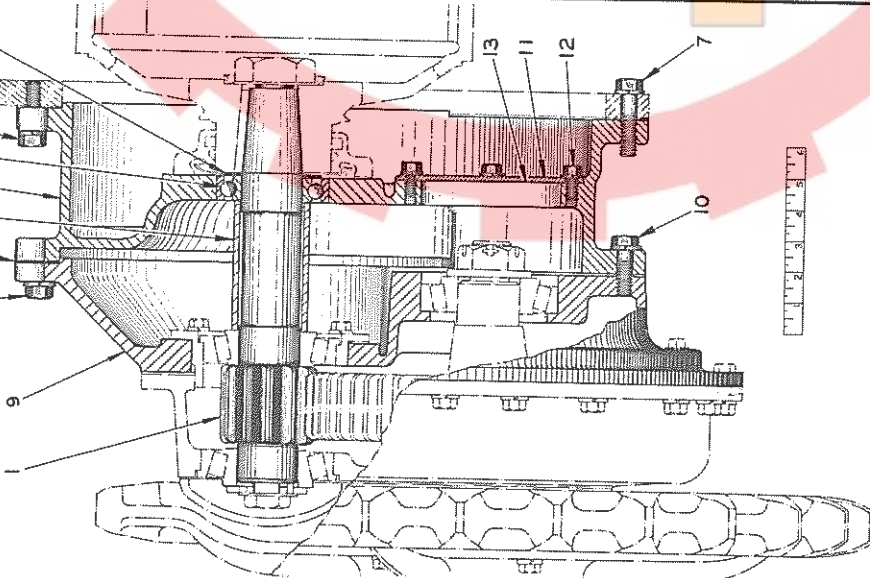

FIRST TYPE

USED ON TRACTORS PRIOR TO NO. 238 ONLY

TRANSMISSION CASE

15 22 23 19 17 16 18 20

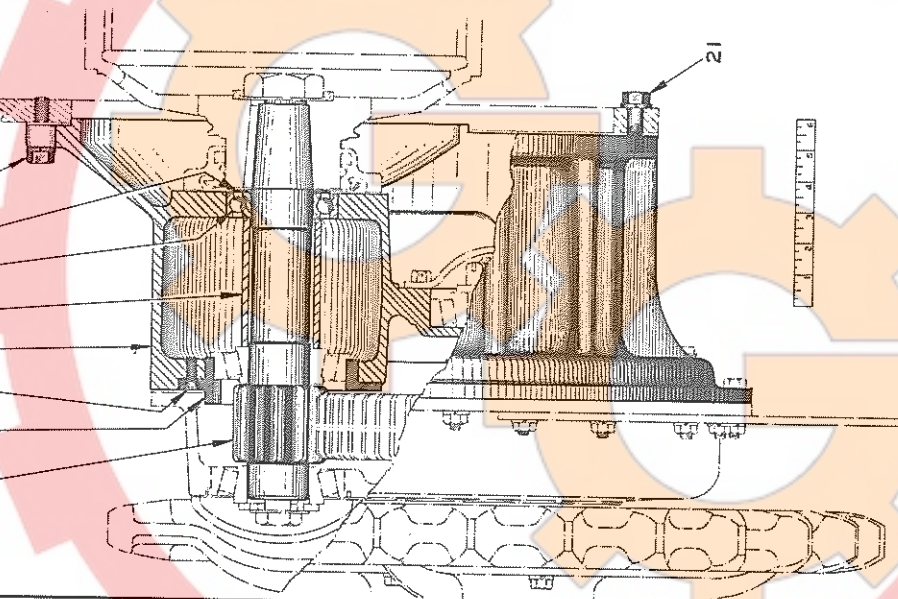

SECOND TYPE

USED ON TRACTORS NO. 238 THRU NO. 2941 ONLY

TRANSMISSION CASE

24 32 36 33 26 25 27 29 34 28

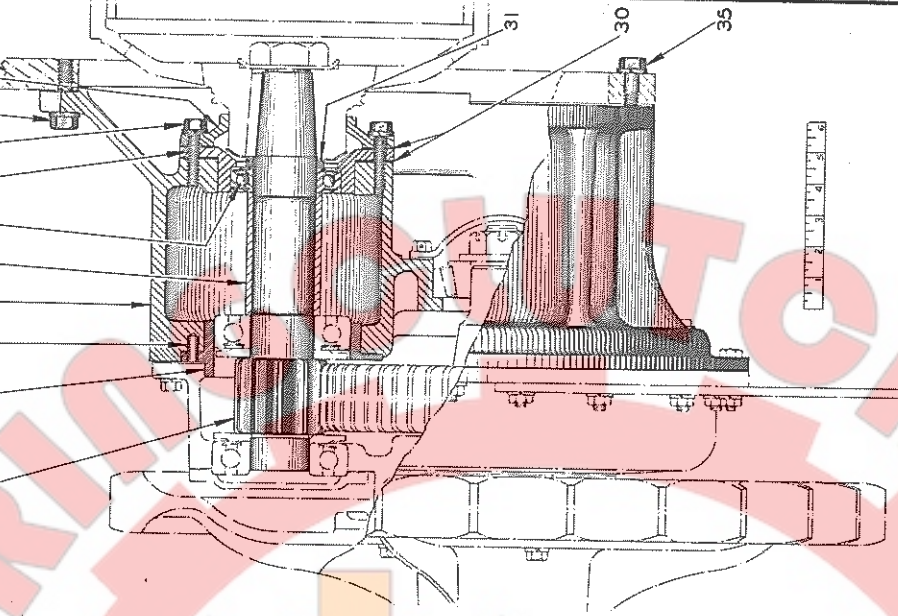

THIRD TYPE

USED ON TRACTORS AFTER NO. 2941

PLATE 1773—SPECIAL FINAL DRIVE PARTS FOR 50" TREAD MODEL

SPECIAL FINAL DRIVE PARTS FOR 50" TREAD MODEL

(See Plate 1773)

NOTE: See preceding pages for parts common to both 40" tread and 50" tread Models.

<u>ITEM</u>	<u>PART NUMBER</u>	<u>QTY.</u>	<u>DESCRIPTION</u>	<u>PACKAGE OR KIT NUMBER</u>
			FIRST TYPE - Used on tractors prior to #238	
1	045528	2	PINION (12 teeth, 13-3/8" long)	
2	042833	2	BEARING, ball, pinion shaft - inner	
3	045526	2	SPACER, pinion shaft inner bearing	
4	045527	2	WASHER, pinion shaft inner bearing	
5	045677	1	SPACER - left (Not serviced. See NOTE below)	
	045678	1	SPACER - right (Not serviced. See NOTE below)	
6	035236	24	CAPSCREW, hex-hd., 1/2"NC x 1-3/4"	
	904208	24	LOCKWASHER, 1/2"	
7	AM-8801	10	CAPSCREW, hex-hd., 1/2"NC x 2"	
	904208	10	LOCKWASHER, 1/2"	
			NOTE: As a replacement for either SPACER 045677 or 045678 use 1 CASE 045654, 1 RETAINER 045843, 4 CAPSCREW 070192, 1 COVER 045028, 1 GASKET 045030 and 15 CAPSCREW 035336)	
8	045032	2	GASKET, gear case to spacer	
9	045667	1	CASE, inner half - left	
	045668	1	CASE, inner half - right	
10	035190	28	CAPSCREW, hex-hd., 1/2"NC x 1-1/2"	
	904208	29	LOCKWASHER, 1/2"	
11	045670	2	PLATE, cover (5-1/4" diam.) (Used prior to tractor #42)	
	045734	2	PLATE, cover (5-3/4" diam.) (Used after tractor #41)	
12	035244	8	CAPSCREW, hex-hd., 3/8"NC x 3/4"	
	904206	8	LOCKWASHER, 3/8"	
13	045669	2	GASKET, cover plate (5-1/4" diam.) (Used prior to tractor #42)	
	045733	2	GASKET, cover plate (5-3/4" diam.) (Used after tractor #41)	
			SECOND TYPE - Used on tractors #238 thru #2941	
15	045528	2	PINION (12 teeth, 13-3/8" long)	
16	042833	2	BEARING, ball, pinion shaft - inner	
17	045526	2	SPACER, pinion shaft inner bearing	
18	045527	2	WASHER, pinion shaft inner bearing	
19	045654	2	CASE, gear - inner half	
20	035236	24	CAPSCREW, hex-hd., 1/2"NC x 1-3/4"	
	904208	24	LOCKWASHER, 1/2"	
21	AM-8801	10	CAPSCREW, hex-hd., 1/2"NC x 2"	
	904208	10	LOCKWASHER, 1/2"	
22	045843	2	RETAINER, pinion shaft center bearing	
23	070192	8	CAPSCREW, flat head, 3/8"NC x 1-1/8"	
			THIRD TYPE - Used on tractors after #2941	
24	030824	2	PINION (12 teeth, 13-3/8" long)	
25	042833	2	BEARING, ball, pinion shaft - inner	
26	030561	2	SPACER, pinion shaft inner bearing	
27	030562	2	CAGE, pinion shaft inner bearing	
28	030825	2	CAGE, oil return	
29	028271	8	CAPSCREW, hex-hd., 3/8"NC x 1-3/4"	
	904206	8	LOCKWASHER, 3/8"	
30	045046	4	GASKET, pinion shaft inner bearing cage	
31	030560	2	SPACER, pinion shaft inner bearing	
32	030131	2	RETAINER, pinion shaft center bearing	

(Continued)