

100E

PAY loader
Specifications

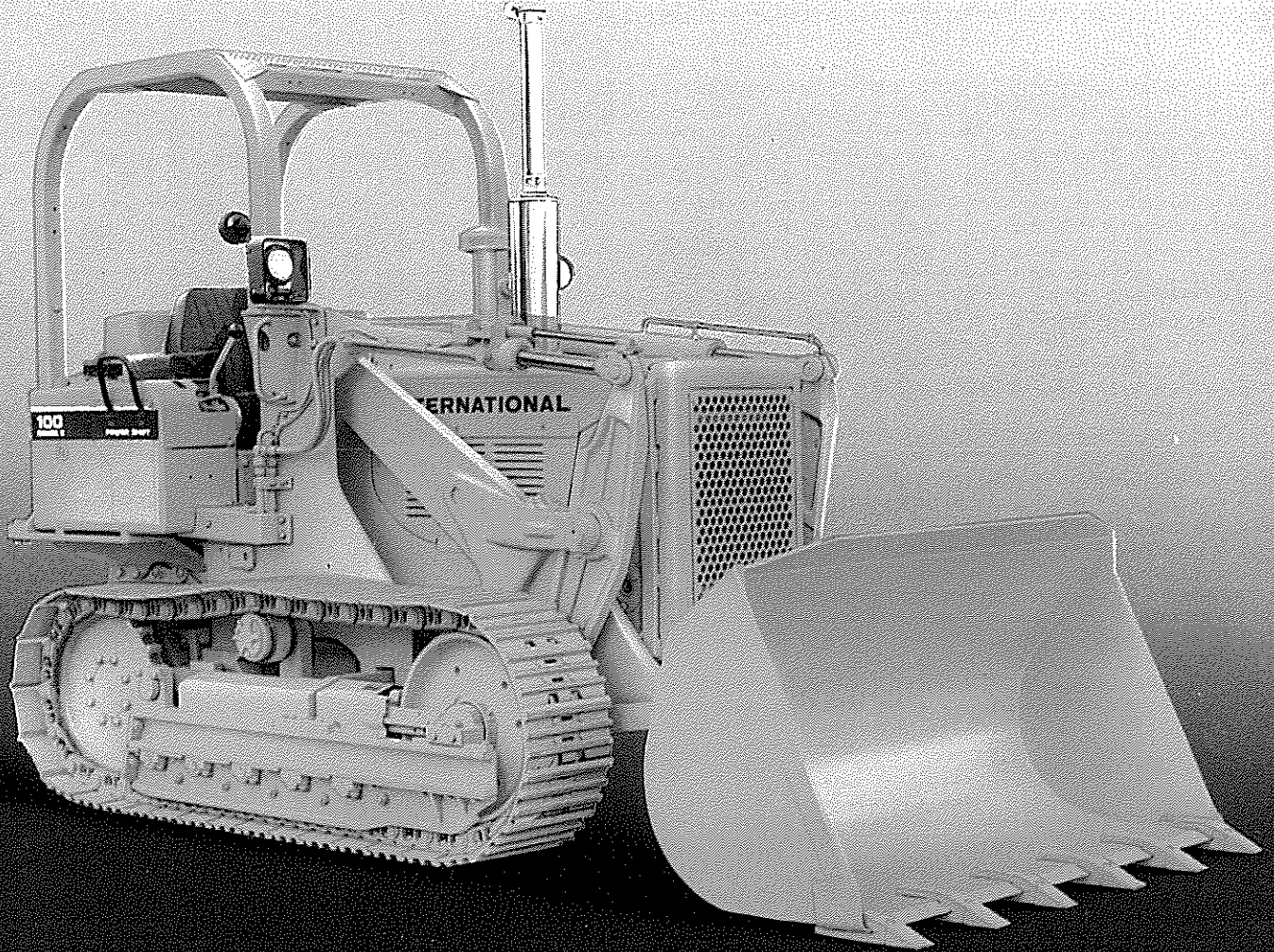

PAY LINE DIVISION

International[®]

100E PAY loader

OPTIONAL ATTACHMENTS (Partial List)

- Accumulator
- Backhoe, 3142A
 - Bucket, heavy duty w/replaceable teeth
 - 0.17m³ 610mm (24" 6ft³)
- Counterweight, ripper-mounted
- Fan, reversible
- Horn, warning
- Hydraulic Equipment
 - Optional hydraulic valve arrangement
- Ripper, #395 with 3-teeth
- ROPS Equipment
- Screen, rear
- Sweeps, front
- Winch, Gearmatic 19
 - Fairlead, 3-roller, and mounting
 - Logging arch, Model 78

395 RIPPER

Overall width m	1.39	(4'6.6")
Hydraulic cylinders (2) double acting		
Bore & Stroke, mm (in)	76 x 172	(3 x 6.8)
Std. number of teeth (w/provisions for 5)		3
Tooth spacing for 5 teeth, mm (in)	330	(13.0)
Ripper tips		Replaceable
Length (rear-most point to centerline of sprocket), m	0.99	(3'3")
Weight (incl. hyd.) approx., kg (lb)	454	(1000)

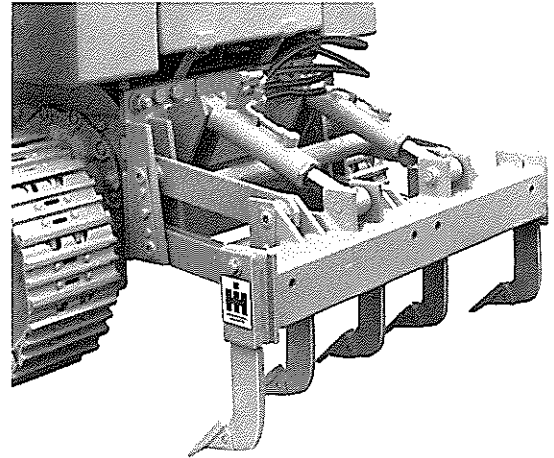

3142A BACKHOE

[Specs based on 610 mm 0.17 m³ (24" 6 ft³) bucket]

Max. digging depth, m	4.41	(14'5.5")
Swing arc	180°	
Reach from swing pivot, m	5.51	(18'1")
Transport height, m	3.92	(12'10.5")
Loading height, m	3.87	(12'8.5")
Bucket rotation	178°	
*Max. digging force — bucket, kN (lb)	42.3	(9519)
*Max. digging force — dipperstick kN (lb)	25.5	(5728)
*Based on 14.5 MPa (2150 psi) @ rated engine speed		

GEARMATIC NO. 19 WINCH

Drive	Mechanical	
Control	Full hydraulic	
Cable drum size:		
Barrel diameter, mm (in)	216	(8.5)
Cable drum capacity: m (ft)		
12.7 mm (1/2")	110.95	(364)
14.3 mm (9/16")	88.39	(290)
15.9 mm (5/8")	73.15	(240)
19.1 mm (3/4")	51.51	(169)
Drum control:		
Clutch	Friction w/free spc	
Brake	Normally engaged	
Drum rotation	Overwind	
Max. line pull:		
Bare drum, kg (lb)	12866	(28,360)
Full drum, kg (lb)	7924	(17,470)
Line speed—no load:		
Bare drum m/min (fpm)	57.91	(190)
Full drum m/min (fpm)	96.01	(315)

Specifications subject to change without notice. Illustrations may include optional equipment and accessories and may not include all standard equipment. PAY is a registered trademark of International Harvester Company designating a family of IH products.



INTERNATIONAL HARVESTER

PAY LINE DIVISION